

**FCC PART 15 SUBPART B and C
TEST REPORT***for***COMCAST XR2 RF4CE 2 DEVICE 2013****Model: URC-4268BC1-XXXX-R**

Prepared for

UNIVERSAL ELECTRONICS, INC.
201 EAST SANDPOINTE AVENUE, 8TH FLOOR
SANTA ANA, CALIFORNIA 92707

Prepared by: _____

ALEX BENITEZ

Approved by: _____

KYLE FUJIMOTO

COMPATIBLE ELECTRONICS INC.
114 OLINDA DRIVE
BREA, CALIFORNIA 92823
(714) 579-0500

DATE: FEBRUARY 21, 2013

	REPORT	APPENDICES					TOTAL
	BODY	A	B	C	D	E	
PAGES	16	2	2	2	13	42	77

This report shall not be reproduced except in full, without the written approval of Compatible Electronics.

TABLE OF CONTENTS

Section / Title	PAGE
GENERAL REPORT SUMMARY	4
SUMMARY OF TEST RESULTS	4
1. PURPOSE	5
2. ADMINISTRATIVE DATA	6
2.1 Location of Testing	6
2.2 Traceability Statement	6
2.3 Cognizant Personnel	6
2.4 Date Test Sample was Received	6
2.5 Disposition of the Test Sample	6
2.6 Abbreviations and Acronyms	6
3. APPLICABLE DOCUMENTS	7
4. DESCRIPTION OF TEST CONFIGURATION	8
4.1 Description of Test Configuration – Emissions	8
4.1.1 Cable Construction and Termination	8
5. LISTS OF EUT, ACCESSORIES AND TEST EQUIPMENT	9
5.1 EUT and Accessory List	9
5.2 Emissions Test Equipment	10
6. TEST SITE DESCRIPTION	11
6.1 Test Facility Description	11
6.2 EUT Mounting, Bonding and Grounding	11
6.3 Facility Environmental Characteristics	11
7. TEST PROCEDURES	12
7.1 RF Emissions	12
7.1.1 Conducted Emissions Test	12
7.1.2 Radiated Emissions (Spurious and Harmonics) Test	13
7.1.3 RF Emissions Test Results	15
8. CONCLUSIONS	16

LIST OF APPENDICES

APPENDIX	TITLE
A	Laboratory Accreditations and Recognitions
B	Modifications to the EUT
C	Additional Models Covered Under This Report
D	Diagram, Charts, and Photos <ul style="list-style-type: none">• Test Setup Diagram• Antenna and Amplifier Factors• Radiated Emissions Photos
E	Data Sheets

LIST OF FIGURES

FIGURE	TITLE
1	Conducted Emissions Test Setup
2	Plot Map And Layout of the Radiated Test Site

GENERAL REPORT SUMMARY

Compatible Electronics Inc. generates this electromagnetic emission test report, which is an independent testing and consulting firm. The test report is based on testing performed by Compatible Electronics personnel according to the measurement procedures described in the test specifications given below and in the "Test Procedures" section of this report.

The measurement data and conclusions appearing herein relate only to the sample tested and this report may not be reproduced without the written permission of Compatible Electronics, unless done so in full.

This report must not be used to claim product endorsement by NVLAP, NIST or any other agency of the U.S. Government.

Device Tested: Comcast XR2 RF4CE 2 Device 2013
Model: URC-4268BC1-XXXX-R
S/N: N/A

Product Description: See Expository Statement

Modifications: The EUT was not modified in order to meet the specifications.

Customer: Universal Electronics, Inc.
201 East Sandpointe Avenue, 8th Floor
Santa Ana, California 92707

Manufacturer: Gemstar Technology Company, LTD.
Gemstar Industrial Park,
Shi Guang Road Number 45
Zhongcun Town, Panyu
Guangdong Province, China 511495

Test Date(s): February 11 and 19, 2013

Test Specifications: Emissions requirements
CFR Title 47, Part 15, Subpart B and Subpart C, Sections 15.205, 15.209, and 15.249

Test Procedure: ANSI C63.4

Test Deviations: The test procedure was not deviated from during the testing.

SUMMARY OF TEST RESULTS

TEST	DESCRIPTION	RESULTS
1	Conducted RF Emissions 150 kHz to 30 MHz	This test was not performed because the EUT operates on battery power.
2	Radiated RF Emissions 10 kHz to 25000 MHz (Transmitter and Digital Portion)	Complies with the Class B limits of CFR Title 47, Part 15, Subpart B; and Subpart C, sections 15.205, 15.209, and 15.249.

1. PURPOSE

This document is a qualification test report based on the emissions tests performed on the Comcast XR2 RF4CE 2 Device 2013, Model: URC-4268BC1-XXXX-R (EUT). The Emissions measurements were performed according to the measurement procedure described in ANSI C63.4. The tests were performed in order to determine whether the electromagnetic emissions from the equipment under test, referred to as EUT hereafter, are within the Class B specification limits defined by CFR Title 47, Part 15, Subpart B for the digital portion; and the limits defined in Subpart C, sections 15.205, 15.209, and 15.249 for the transmitter portion.

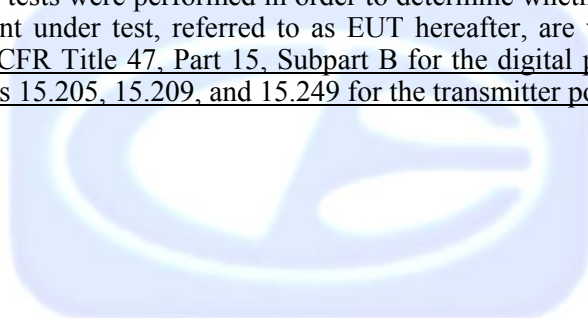

2. ADMINISTRATIVE DATA

2.1 Location of Testing

The Emissions tests described herein were performed at the test facility of Compatible Electronics, 114 Olinda Drive, Brea, California.

2.2 Traceability Statement

The calibration certificates of all test equipment used during the test are on file at the location of the test. The calibration is traceable to the National Institute of Standards and Technology (NIST).

2.3 Cognizant Personnel

Universal Electronics, Inc.

Jesse Mendez Senior Electrical Core Engineer

Compatible Electronics Inc.

Alex Benitez Test Technician

Kyle Fujimoto Test Engineer

2.4 Date Test Sample was Received

The test sample was received on the initial test date of November 29, 2012.

2.5 Disposition of the Test Sample

The test sample has not been returned to Universal Electronics, Inc. as of the date of the test report.

2.6 Abbreviations and Acronyms

The following abbreviations and acronyms may be used in this document.

FCC	Federal Communications Commission
RF	Radio Frequency
EMI	Electromagnetic Interference
EUT	Equipment Under Test
P/N	Part Number
S/N	Serial Number
ITE	Information Technology Equipment
LISN	Line Impedance Stabilization Network
NVLAP	National Voluntary Laboratory Accreditation Program
CFR	Code of Federal Regulations
N/A	Not Applicable
Ltd.	Limited
Inc.	Incorporated
NCR	No Calibration Required

3. APPLICABLE DOCUMENTS

The following documents are referenced or used in the preparation of this Emissions Test Report.

SPEC	TITLE
CFR Title 47, Part 15	FCC Rules – Radio frequency devices (including digital devices)
ANSI C63.4: 2009	American National Standard for Methods of Measurement of Radio-Noise Emissions from Low-Voltage Electrical and Electronic Equipment in the Range of 9 kHz to 40 GHz

4. DESCRIPTION OF TEST CONFIGURATION

4.1 Description of Test Configuration – Emissions

The Comcast XR2 RF4CE 2 Device 2013, Model: URC-4268BC1-XXXX-R (EUT) was tested as a stand alone unit. The EUT had a special test program that allowed the low, middle, or high channels, to be tested while continuously transmitting. The EUT was tested in three orthogonal axis.

It was determined that the emissions were at their highest level when the EUT was operating in the above configuration. The final emissions data was taken in this mode of operation and any cables were maximized. All initial investigations were performed with the measurement receiver in manual mode scanning the frequency range continuously. Photographs of the test setup are in Appendix D of this report.

4.1.1 Cable Construction and Termination

There were no external cables connected to the EUT.

5. LISTS OF EUT, ACCESSORIES AND TEST EQUIPMENT**5.1 EUT and Accessory List**

EQUIPMENT	MANUFACTURER	MODEL NUMBER	SERIAL NUMBER	FCC ID
COMCAST XR2 RF4CE 2 DEVICE 2013 (EUT)	UNIVERSAL ELECTRONICS, INC.	URC-4268BC1-XXXX-R	N/A	MG3- 4268BC1
LAPTOP**	LENOVO	T61	*P.ID: 7667RWU	N/A
LAPTOP POWER SUPPLY**	IBM	P/N: 92P1113	11592P1113Z1A CW58NOJ2	N/A

*P.ID = Product ID

**Only used to program the EUT. The laptop and its power supply were then removed and the EUT was tested in stand-alone mode.

5.2 Emissions Test Equipment

EQUIPMENT TYPE	MANUFACTURER	MODEL NUMBER	SERIAL NUMBER	CALIBRATION DATE	CALIBRATION CYCLE
GENERAL TEST EQUIPMENT USED IN LAB B					
Computer	Compaq	CQ5210F	CNX9360CF9	N/A	N/A
Monitor	Hewlett Packard	HPs2031a	3CQ046N3MD	N/A	N/A
EMI Receiver	Rohde & Schwarz	ESIB40	100194	November 19, 2012	2 Years
GENERAL TEST EQUIPMENT USED IN LAB D					
Computer	Hewlett Packard	p6716f	MXX1030PX0	N/A	N/A
Monitor	Hewlett Packard	HPs2031a	3CQ046N3MG	N/A	N/A
Spectrum Analyzer – Main Section	Hewlett Packard	8568B	2517A01563	May 30, 2012	1 Year
Spectrum Analyzer – Display Section	Hewlett Packard	85662A	2648A15285	May 30, 2012	1 Year
Quasi-Peak Adapter	Hewlett Packard	85650A	2430A00424	May 30, 2012	1 Year
RF RADIATED EMISSIONS TEST EQUIPMENT					
Biconical Antenna	Com Power	AB-900	43028	May 24, 2012	1 Year
Log Periodic Antenna	Com Power	AL-100	16252	May 24, 2012	1 Year
Preamplifier	Com-Power	CPPA-102	1017	December 27, 2012	1 Year
Preamplifier	Com-Power	PA-118	181656	December 27, 2012	1 Year
Preamplifier	Com-Power	PA-840	711013	May 17, 2012	1 Year
Loop Antenna	Com-Power	AL-130	17089	January 29, 2013	2 Years
Horn Antenna	Com-Power	AH-118	071175	February 29, 2012	2 Years
Horn Antenna	Com-Power	AH-826	0071957	N/A	N/A
Antenna Mast	Com Power	AM-100	N/A	N/A	N/A

6. TEST SITE DESCRIPTION**6.1 Test Facility Description**

Please refer to section 2.1 and 7.1.2 of this report for Emissions test location.

6.2 EUT Mounting, Bonding and Grounding

The EUT was mounted on a 1.0 by 1.5 meter non-conductive table 0.8 meters above the ground plane.

The EUT was not grounded.

6.3 Facility Environmental Characteristics

When applicable refer to the data sheets in Appendix E for the relative humidity, air temperature, and barometric pressure.

7. TEST PROCEDURES

The following sections describe the test methods and the specifications for the tests. Test results are also included in this section.

7.1 RF Emissions

7.1.1 Conducted Emissions Test

The measurement receiver was used as a measuring meter. The data was collected with the measurement receiver in the peak detect mode with the "Max Hold" feature activated. The quasi-peak was used only where indicated in the data sheets. A transient limiter was used for the protection of the measurement receiver's input stage, and the offset was adjusted accordingly to read the actual data measured. The LISN output was measured using the measurement receiver. The output of the second LISN was terminated by a 50-ohm termination. The effective measurement bandwidth used for this test was 9 kHz.

Please see section 6.2 of this report for mounting, bonding and grounding of the EUT. The EUT was powered through the LISN, which was bonded to the ground plane. The LISN power was filtered and the filter was bonded to the ground plane. The EUT was set up with the minimum distances from any conductive surfaces as specified in ANSI C63.4. The excess power cord was wrapped in a figure eight pattern to form a bundle not exceeding 0.4 meters in length.

The conducted emissions from the EUT were maximized for operating mode as well as cable placement. The final data was collected under program control by the Compatible Electronics conducted emissions software in several overlapping sweeps by running the spectrum analyzer at a minimum scan rate of 10 seconds per octave. The final qualification data is located in Appendix E.

Test Results:

This test was not performed because the EUT operates on battery power.

7.1.2 Radiated Emissions (Spurious and Harmonics) Test

The spectrum analyzer, along with the quasi-peak adapter, and EMI Receiver were used as a measuring meter. Amplifiers were used to increase the sensitivity of the instrument. The Com-Power Preamplifier Model: CPPA-102 was used for frequencies from 30 MHz to 1 GHz, the Com-Power Microwave Preamplifier Model: PA-118 was used for frequencies from 1 GHz to 18 GHz, and the Com-Power Microwave Preamplifier Model: PA-840 were used for frequencies above 18 GHz. The spectrum analyzer and EMI Receiver were used in the peak detect mode with the "Max Hold" feature activated. In this mode, the spectrum analyzer and EMI receiver records the highest measured reading over the sweeps.

The quasi-peak function was used only for those readings which are marked accordingly on the data sheets.

The frequencies above 1 GHz were adjusted by a "duty cycle correction factor", derived from $20 \log(\text{dwell time} / 100 \text{ mS})$.

The measurement bandwidths and transducers used for the radiated emissions test were:

FREQUENCY RANGE	EFFECTIVE MEASUREMENT BANDWIDTH	TRANSDUCER
10 kHz to 150 kHz	200 Hz	Active Loop Antenna
150 kHz to 30 MHz	9 kHz	Active Loop Antenna
30 MHz to 300 MHz	120 kHz	Biconical Antenna
300 MHz to 1 GHz	120 kHz	Log Periodic Antenna
1 GHz to 25 GHz	1 MHz	Horn Antennas

The open field test site of Compatible Electronics, Inc. was used for radiated emission testing. This test site is set up according to ANSI C63.4. Please see section 6.2 of this report for mounting, bonding and grounding of the EUT. The turntable supporting the EUT is remote controlled using a motor. The turntable permits EUT rotation of 360 degrees in order to maximize emissions. Also, the antenna mast allows height variation of the antenna from 1 meter to 4 meters. Data was collected in the worst case (highest emission) configuration of the EUT by the Radiated Emission Manual Test software. At each reading, the EUT was rotated 360 degrees and the antenna height was varied from 1 to 4 meters (for E field radiated field strength). The gun sight method was used when measuring with the horn antenna in order to ensure accurate results. The loop antenna was also rotated in the vertical axis in order to ensure accurate results.

Radiated Emissions (Spurious and Harmonics) Test (continued)

The presence of ambient signals was verified by turning the EUT off. In case an ambient signal was detected, the measurement bandwidth was reduced temporarily and verification was made that an additional adjacent peak did not exist. This ensures that the ambient signal does not hide any emissions from the EUT. The EUT was tested at a 3-meter test distance from 30 MHz to 25 GHz and at a 10-meter distance from 10 kHz to 30 MHz to obtain the final test data.

Test Results:

The EUT complies with the **Class B** limits of CFR Title 47, Part 15, Subpart B; and the limits of CFR Title 47, Part 15, Subpart C, Sections 15.209 and 15.249.

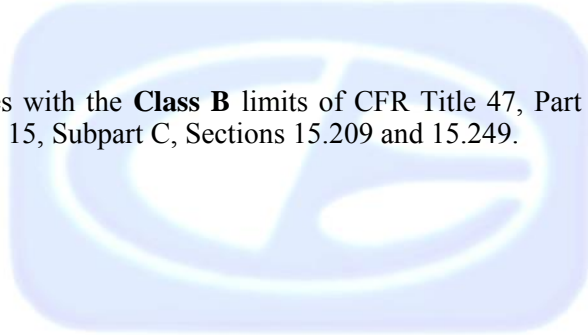

7.1.3 RF Emissions Test Results

Table 1.0 RADIATED EMISSION RESULTS
Comcast XR2 RF4CE 2 Device 2013, Model: URC-4268BC1-XXXX-R

Frequency MHz	Corrected Reading* dBuV	Specification Limit dBuV	Delta (Cor. Reading – Spec. Limit) dB
Middle Channel 4900 (Average) (H)	37.21 (X-Axis) (Antenna 0)	54	-16.79
High Channel 2475 (Average) (H)	76.92 (X-Axis) (Antenna 1)	94	-17.08
Middle Channel 4900 (Average) (V)	36.74 (Y-Axis) (Antenna 0)	54	-17.26
High Channel 2475 (Average) (V)	76.43 (Y-Axis) (Antenna 1)	94	-17.57
Low Channel 4850 (Average) (V)	36.37 (Y-Axis) (Antenna 0)	54	-17.63
Low Channel 2425 (Average) (H)	76.27 (X-Axis) (Antenna 1)	94	-17.73

Notes:

- * The complete emissions data is given in Appendix E of this report.
- (H) Horizontal
- (V) Vertical

8. CONCLUSIONS

The Comcast XR2 RF4CE 2 Device 2013, Model: URC-4268BC1-XXXX-R (EUT), as tested, meets all of the Class B specification limits defined in CFR Title 47, Part 15, Subpart B for the digital portion; and the limits defined in Subpart C, sections 15.205, 15.209, and 15.249 for the transmitter portion.





APPENDIX A

LABORATORY ACCREDITATIONS AND RECOGNITIONS

Brea Division
114 Olinda Drive
Brea, CA 92823
(714) 579-0500

Agoura Division
2337 Troutdale Drive
Agoura, CA 91301
(818) 597-0600

Silverado Division
19121 El Toro Road
Silverado, CA 92676
(949) 589-0700

Lake Forest Division
20621 Pascal Way
Lake Forest, CA 92630
(949) 587-0400

LABORATORY ACCREDITATIONS AND RECOGNITIONS



For US, Canada, Australia/New Zealand, Japan, Taiwan, Korea, and the European Union, Compatible Electronics is currently accredited by NVLAP to ISO/IEC 17025. Please follow the link to the NIST/NVLAP site for each of our facilities' NVLAP certificate and scope of accreditation

NVLAP listing links

[Agoura Division](#) / [Brea Division](#) / [Silverado/Lake Forest Division](#)

.Quote from ISO-ILAC-IAF Communiqué on 17025:

"A laboratory's fulfillment of the requirements of ISO/IEC 17025:2005 means the laboratory meets both the technical competence requirements and management system requirements that are necessary for it to consistently deliver technically valid test results and calibrations. The management system requirements in ISO/IEC 17025:2005 (Section 4) are written in language relevant to laboratory operations and meet the principles of ISO 9001:2008 Quality Management Systems — Requirements."



ANSI listing [CETCB](#)



Compatible Electronics has been nominated as a Conformity Assessment Body (CAB) for EMC under the US/EU Mutual Recognition Agreement (MRA).

US/EU MRA list [NIST MRA site](#)



Compatible Electronics has been nominated as a Conformity Assessment Body (CAB) for Taiwan/BSMI under the US/APEC (Asia-Pacific Economic Cooperation) Mutual Recognition Agreement (MRA).

APEC MRA list [NIST MRA site](#)

We are also listed for IT products by the following country/agency:



VCCI Support member: Please visit http://www.vcci.jp/vcci_e/



FCC Listing, from FCC OET site

[FCC test lab search](https://fjallfoss.fcc.gov/oetcf/eas/reports/TestFirmSearch.cfm) <https://fjallfoss.fcc.gov/oetcf/eas/reports/TestFirmSearch.cfm>



Compatible Electronics IC listing can be found at:

<http://www.ic.gc.ca/eic/site/ic1.nsf/eng/home>

APPENDIX B

MODIFICATIONS TO THE EUT

MODIFICATIONS TO THE EUT

The modifications listed below were made to the EUT to pass FCC 15.249 and/or FCC **Class B** specifications.

All the rework described below was implemented during the test in a method that could be reproduced in all the units by the manufacturer.

No modifications were made to the EUT during the testing.





APPENDIX C

***ADDITIONAL MODELS COVERED
UNDER THIS REPORT***

Brea Division
114 Olinda Drive
Brea, CA 92823
(714) 579-0500

Agoura Division
2337 Troutdale Drive
Agoura, CA 91301
(818) 597-0600

Silverado Division
19121 El Toro Road
Silverado, CA 92676
(949) 589-0700

Lake Forest Division
20621 Pascal Way
Lake Forest, CA 92630
(949) 587-0400

ADDITIONAL MODELS COVERED UNDER THIS REPORT

USED FOR THE PRIMARY TEST

Comcast XR2 RF4CE 2 Device 2013
Model: URC-4268BC1-XXXX-R
S/N: N/A

ALSO APPROVED UNDER THIS REPORT:

There were no additional models covered under this report.



APPENDIX D

DIAGRAMS, CHARTS, AND PHOTOS

FIGURE 1: CONDUCTED EMISSIONS TEST SETUP

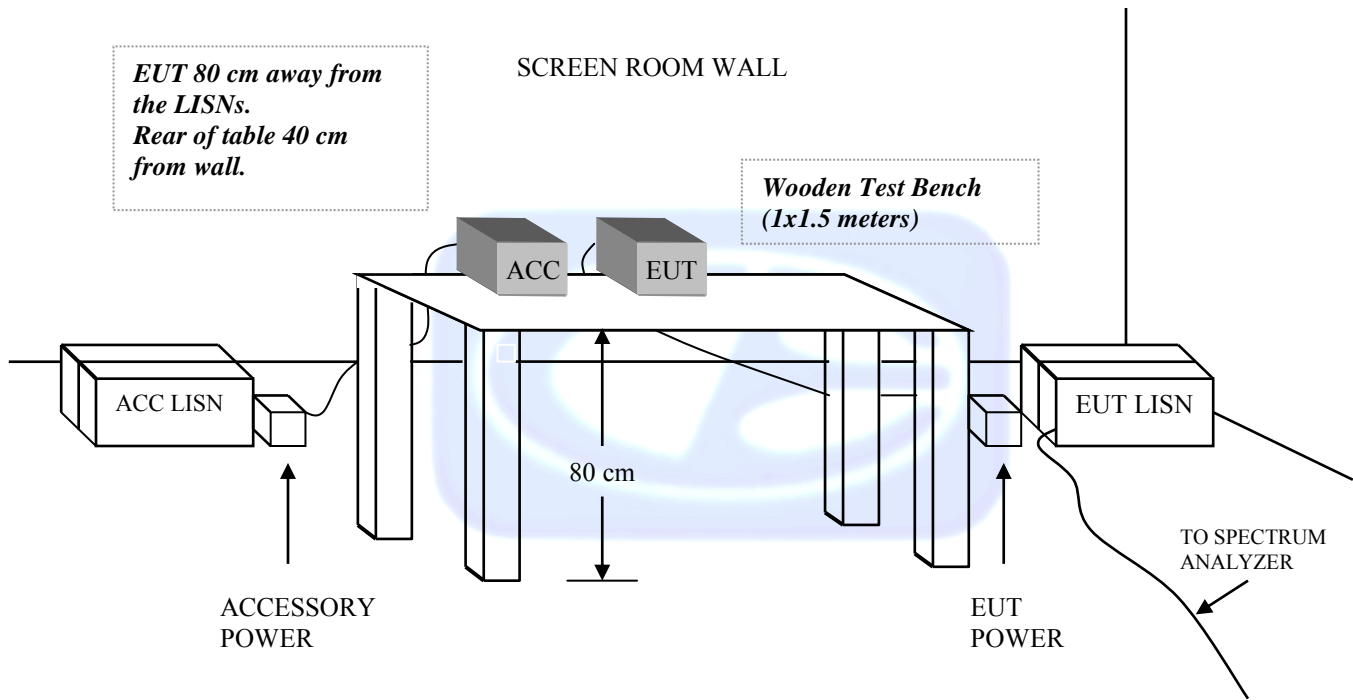
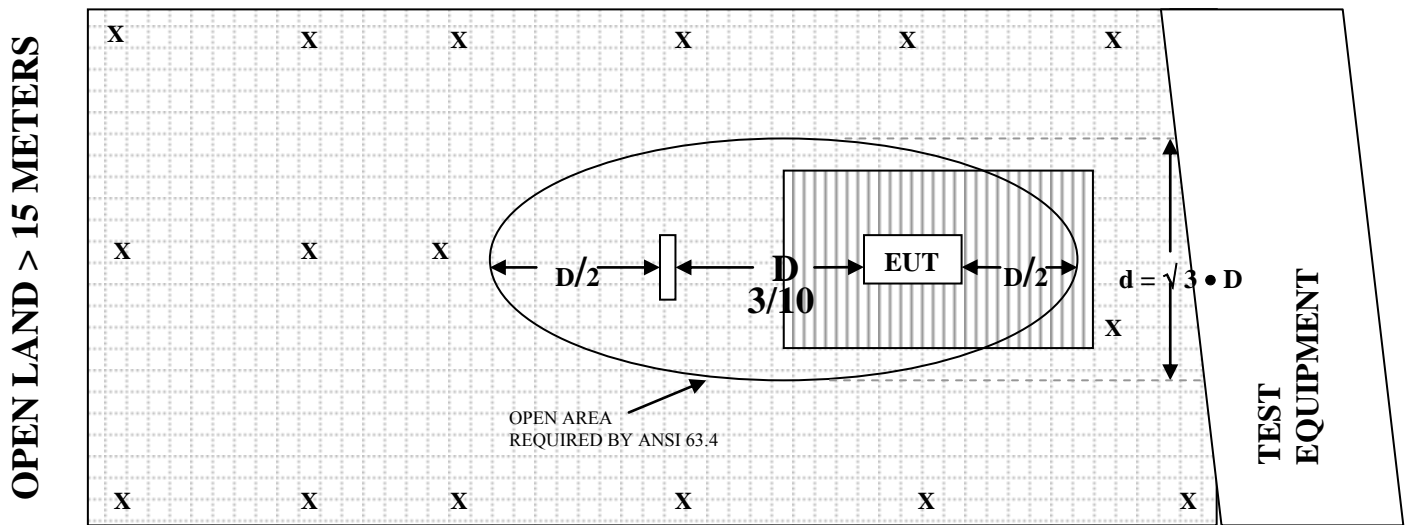

FIGURE 2: PLOT MAP AND LAYOUT OF THE RADIATED TEST SITE

OPEN LAND > 15 METERS



OPEN LAND > 15 METERS

- X = GROUND RODS
- D = TEST DISTANCE (meters)
- = GROUND SCREEN
- = WOOD COVER

COM-POWER AL-130**LOOP ANTENNA**

S/N: 17089

CALIBRATION DATE: JANUARY 29, 2013

FREQUENCY (MHz)	MAGNETIC (dB/m)	ELECTRIC (dB/m)
0.009	-42.5	9
0.01	-42.3	9.2
0.02	-42.1	9.4
0.03	-41.4	10.1
0.04	-41.8	9.7
0.05	-42.4	9.1
0.06	-42.3	9.2
0.07	-42.5	9
0.08	-42.4	9.1
0.09	-42.5	9
0.1	-42.5	9
0.2	-42.7	8.8
0.3	-42.6	8.9
0.4	-42.5	9
0.5	-42.7	8.8
0.6	-42.7	8.8
0.7	-42.5	9
0.8	-42.3	9.2
0.9	-42.2	9.3
1	-42.2	9.3
2	-41.8	9.7
3	-41.7	9.8
4	-41.7	9.8
5	-41.5	10
6	-41.6	9.9
7	-41.4	10.1
8	-41	10.5
9	-40.8	10.7
10	-41.3	10.2
15	-41.4	10.1
20	-41.2	10.3
25	-42.6	8.9
30	-41.7	9.8

COM-POWER AB-900**BICONICAL ANTENNA**

S/N: 43028

CALIBRATION DATE: MAY 24, 2012

FREQUENCY (MHz)	FACTOR (dB)	FREQUENCY (MHz)	FACTOR (dB)
30	11.80	120	13.20
35	11.20	125	13.30
40	11.90	140	11.60
45	10.70	150	11.80
50	11.40	160	12.70
60	10.30	175	14.80
70	7.60	180	15.70
80	5.70	200	15.80
90	7.90	250	14.80
100	10.70	300	19.80

COM-POWER AL-100**LOG PERIODIC ANTENNA**

S/N: 16252

CALIBRATION DATE: MAY 24, 2012

FREQUENCY (MHz)	FACTOR (dB)	FREQUENCY (MHz)	FACTOR (dB)
300	13.00	700	20.30
350	13.20	750	20.80
400	14.50	800	21.00
450	15.40	850	23.30
500	15.80	900	21.70
550	16.60	950	24.20
600	18.90	1000	24.30
650	19.10		

COM POWER AH-118**HORN ANTENNA**

S/N: 071175

CALIBRATION DATE: FEBRUARY 29, 2012

FREQUENCY (GHz)	FACTOR (dB)	FREQUENCY (GHz)	FACTOR (dB)
1.0	23.6	10.0	37.7
1.5	22.0	10.5	38.4
2.0	28.7	11.0	38.0
2.5	29.3	11.5	38.2
3.0	30.6	12.0	39.0
3.5	30.4	12.5	42.4
4.0	31.1	13.0	40.8
4.5	33.4	13.5	40.0
5.0	35.3	14.0	39.7
5.5	35.1	14.5	43.5
6.0	36.9	15.0	42.7
6.5	37.4	15.5	39.7
7.0	37.6	16.0	39.2
7.5	36.2	16.5	39.7
8.0	38.4	17.0	42.2
8.5	39.3	17.5	47.6
9.0	37.4	18.0	51.2
9.5	38.0		

COM-POWER AH-826**HORN ANTENNA**

S/N: 0071957

FREQUENCY (GHz)	FACTOR (dB)	FREQUENCY (GHz)	FACTOR (dB)
18.0	33.5	22.5	35.5
18.5	33.5	23.0	35.9
19.0	34.0	23.5	35.7
19.5	34.0	24.0	35.6
20.0	34.3	24.5	36.0
20.5	34.9	25.0	36.2
21.0	34.7	25.5	36.1
21.5	35.0	26.0	36.2
22.0	35.0	26.5	35.7

COM-POWER CPPA-102**PREAMPLIFIER**

S/N: 1017

CALIBRATION DATE: DECEMEBER 27, 2012

FREQUENCY (MHz)	FACTOR (dB)	FREQUENCY (MHz)	FACTOR (dB)
1	36.9	225	38.14
3	38.1	250	38.15
5	38.1	275	38.14
8	38.2	300	38.18
10	38.3	350	38.22
20	38.2	400	38.26
30	38.3	450	37.53
40	38.2	500	38.24
50	38.5	550	38.53
60	38.5	600	38.69
70	38.4	650	38.66
80	38.4	700	38.58
90	38.5	750	38.37
100	38.4	800	38.23
125	38.6	850	37.68
150	38.4	900	37.38
175	38.5	950	36.82
200	38.5	1000	36.14

COM-POWER PA-118**PREAMPLIFIER**

S/N: 181656

CALIBRATION DATE: DECEMBER 27, 2012

FREQUENCY (GHz)	FACTOR (dB)	FREQUENCY (GHz)	FACTOR (dB)
1.0	24.68	6.0	25.75
1.1	25.08	6.5	25.28
1.2	25.70	7.0	24.83
1.3	25.98	7.5	24.49
1.4	26.11	8.0	24.38
1.5	26.23	8.5	25.06
1.6	26.34	9.0	25.55
1.7	26.39	9.5	25.32
1.8	26.44	10.0	25.25
1.9	26.45	11.0	24.99
2.0	26.48	12.0	25.08
2.5	26.59	13.0	24.44
3.0	26.67	14.0	25.02
3.5	26.66	15.0	26.12
4.0	26.82	16.0	25.67
4.5	26.46	17.0	24.33
5.0	26.22	18.0	26.75
5.5	25.98		

COM-POWER PA-840**MICROWAVE PREAMPLIFIER**

S/N: 711013

CALIBRATION DATE: MAY 17, 2012

FREQUENCY (GHz)	FACTOR (dB)	FREQUENCY (GHz)	FACTOR (dB)
18.0	25.81	31.0	25.77
19.0	24.57	31.5	25.36
20.0	23.46	32.0	25.15
21.0	22.51	32.5	25.13
22.0	23.85	33.0	25.52
23.0	23.31	33.5	25.24
24.0	24.44	34.0	25.08
25.0	25.42	34.5	25.27
26.0	25.71	35.0	23.99
26.5	25.66	35.5	24.67
27.0	25.84	36.5	24.80
27.5	25.29	37.0	26.27
28.0	25.46	37.5	24.86
28.5	25.58	38.0	24.64
29.0	26.16	38.5	23.46
29.5	26.14	39.0	21.29
30.0	26.01	39.5	20.83
30.5	25.67	40.0	19.96



FRONT VIEW

UNIVERSAL ELECTRONICS, INC.
COMCAST XR2 RF4CE 2 DEVICE 2013
MODEL: URC-4268BC1-XXXX-R
FCC SUBPART B AND C – RADIATED EMISSIONS

**PHOTOGRAPH SHOWING THE EUT CONFIGURATION
FOR MAXIMUM EMISSIONS**



REAR VIEW

UNIVERSAL ELECTRONICS, INC.
COMCAST XR2 RF4CE 2 DEVICE 2013
MODEL: URC-4268BC1-XXXX-R
FCC SUBPART B AND C – RADIATED EMISSIONS

**PHOTOGRAPH SHOWING THE EUT CONFIGURATION
FOR MAXIMUM EMISSIONS**

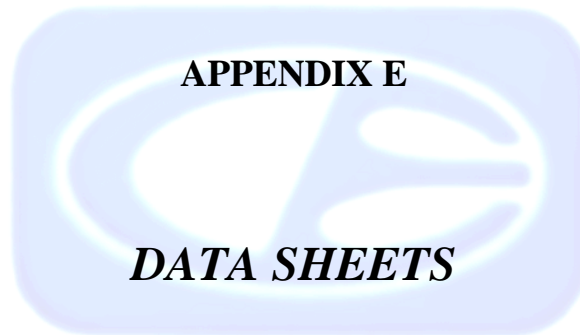

RADIATED EMISSIONS

DATA SHEETS

FCC 15.249

Universal Electronics, Inc.
 Comcast XR2 RF4CE 2 Device 2013
 Model: URC-4268BC1-XXXX-R

Date: 02/11/2013
 Lab: B
 Tested By: Kyle Fujimoto

**Low Channel - Antenna 0
 X-Axis**

Freq. (MHz)	Level (dBuV)	Pol (v/h)	Limit	Margin	Peak / QP / Avg	Ant. Height (m)	Table Angle (deg)	Comments
2425	85.48	V	94	-8.52	Peak	1.25	155	
2425	65.48	V	94	-28.52	Avg	1.25	155	
4850	54.67	V	74	-19.33	Peak	1.35	145	
4850	34.67	V	54	-19.33	Avg	1.35	145	
7275	50.56	V	74	-23.44	Peak	1.25	155	
7275	30.56	V	54	-23.44	Avg	1.25	155	
9700								No Emission Detected
9700								
12125								No Emission Detected
12125								
14550								No Emission Detected
14550								
16975								No Emission Detected
16975								
19400								No Emission Detected
19400								
21825								No Emission Detected
21825								
24250								No Emission Detected
24250								

FCC 15.249

Universal Electronics, Inc.
 Comcast XR2 RF4CE 2 Device 2013
 Model: URC-4268BC1-XXXX-R

Date: 02/11/2013
 Lab: B
 Tested By: Kyle Fujimoto

**Low Channel - Antenna 0
 X-Axis**

Freq. (MHz)	Level (dBuV)	Pol (v/h)	Limit	Margin	Peak / QP / Avg	Ant. Height (m)	Table Angle (deg)	Comments
2425	93.65	H	94	-0.35	Peak	1.25	155	
2425	73.65	H	94	-20.35	Avg	1.25	155	
4850	55.98	H	74	-18.02	Peak	1.25	165	
4850	35.98	H	54	-18.02	Avg	1.25	165	
7275	50.86	H	74	-23.14	Peak	1.35	145	
7275	30.86	H	54	-23.14	Avg	1.35	145	
9700								No Emission Detected
9700								
12125								No Emission Detected
12125								
14550								No Emission Detected
14550								
16975								No Emission Detected
16975								
19400								No Emission Detected
19400								
21825								No Emission Detected
21825								
24250								No Emission Detected
24250								

FCC 15.249

Universal Electronics, Inc.
 Comcast XR2 RF4CE 2 Device 2013
 Model: URC-4268BC1-XXXX-R

Date: 02/11/2013
 Lab: B
 Tested By: Kyle Fujimoto

**Low Channel - Antenna 0
 Y-Axis**

Freq. (MHz)	Level (dBuV)	Pol (v/h)	Limit	Margin	Peak / QP / Avg	Ant. Height (m)	Table Angle (deg)	Comments
2425	92.29	V	94	-1.71	Peak	1.25	155	
2425	72.29	V	94	-21.71	Avg	1.25	155	
4850	56.37	V	74	-17.63	Peak	1.15	225	
4850	36.37	V	54	-17.63	Avg	1.15	225	
7275	52.35	V	74	-21.65	Peak	1.25	265	
7275	32.35	V	54	-21.65	Avg	1.25	265	
9700								No Emission Detected
12125								No Emission Detected
14550								No Emission Detected
16975								No Emission Detected
19400								No Emission Detected
21825								No Emission Detected
24250								No Emission Detected

FCC 15.249

Universal Electronics, Inc.
 Comcast XR2 RF4CE 2 Device 2013
 Model: URC-4268BC1-XXXX-R

Date: 02/11/2013
 Lab: B
 Tested By: Kyle Fujimoto

**Low Channel - Antenna 0
 Y-Axis**

Freq. (MHz)	Level (dBuV)	Pol (v/h)	Limit	Margin	Peak / QP / Avg	Ant. Height (m)	Table Angle (deg)	Comments
2425	89.62	H	94	-4.38	Peak	1.25	265	
2425	69.62	H	94	-24.38	Avg	1.25	265	
4850	51.38	H	74	-22.62	Peak	1.35	275	
4850	31.38	H	54	-22.62	Avg	1.35	275	
7275	50.01	H	74	-23.99	Peak	1.25	285	
7275	30.01	H	54	-23.99	Avg	1.25	285	
9700								No Emission Detected
9700								
12125								No Emission Detected
12125								
14550								No Emission Detected
14550								
16975								No Emission Detected
16975								
19400								No Emission Detected
19400								
21825								No Emission Detected
21825								
24250								No Emission Detected
24250								

FCC 15.249

Universal Electronics, Inc.
 Comcast XR2 RF4CE 2 Device 2013
 Model: URC-4268BC1-XXXX-R

Date: 02/11/2013
 Lab: B
 Tested By: Kyle Fujimoto

**Low Channel - Antenna 0
 Z-Axis**

Freq. (MHz)	Level (dBuV)	Pol (v/h)	Limit	Margin	Peak / QP / Avg	Ant. Height (m)	Table Angle (deg)	Comments
2425	89.54	V	94	-4.46	Peak	1.25	155	
2425	69.54	V	94	-24.46	Avg	1.25	155	
4850	55.97	V	74	-18.03	Peak	1.35	165	
4850	35.97	V	54	-18.03	Avg	1.35	165	
7275	51.31	V	74	-22.69	Peak	1.25	175	
7275	31.31	V	54	-22.69	Avg	1.25	175	
9700								No Emission Detected
9700								
12125								No Emission Detected
12125								
14550								No Emission Detected
14550								
16975								No Emission Detected
16975								
19400								No Emission Detected
19400								
21825								No Emission Detected
21825								
24250								No Emission Detected
24250								

FCC 15.249

Universal Electronics, Inc.
 Comcast XR2 RF4CE 2 Device 2013
 Model: URC-4268BC1-XXXX-R

Date: 02/11/2013
 Lab: B
 Tested By: Kyle Fujimoto

**Low Channel - Antenna 0
 Z-Axis**

Freq. (MHz)	Level (dBuV)	Pol (v/h)	Limit	Margin	Peak / QP / Avg	Ant. Height (m)	Table Angle (deg)	Comments
2425	91.67	H	94	-2.33	Peak	1.25	155	
2425	71.67	H	94	-22.33	Avg	1.25	155	
4850	52.61	H	74	-21.39	Peak	1.55	165	
4850	32.61	H	54	-21.39	Avg	1.55	165	
7275	49.16	H	74	-24.84	Peak	1.25	165	
7275	29.16	H	54	-24.84	Avg	1.25	165	
9700								No Emission Detected
9700								
12125								No Emission Detected
12125								
14550								No Emission Detected
14550								
16975								No Emission Detected
16975								
19400								No Emission Detected
19400								
21825								No Emission Detected
21825								
24250								No Emission Detected
24250								

FCC 15.249

Universal Electronics, Inc.
 Comcast XR2 RF4CE 2 Device 2013
 Model: URC-4268BC1-XXXX-R

Date: 02/11/2013
 Lab: B
 Tested By: Kyle Fujimoto

**Middle Channel - Antenna 0
 X-Axis**

Freq. (MHz)	Level (dBuV)	Pol (v/h)	Limit	Margin	Peak / QP / Avg	Ant. Height (m)	Table Angle (deg)	Comments
2450	87.42	V	94	-6.58	Peak	1.25	155	
2450	67.42	V	94	-26.58	Avg	1.25	155	
4900	52.67	V	74	-21.33	Peak	1.35	165	
4900	32.67	V	54	-21.33	Avg	1.35	165	
7350	52.66	V	74	-21.34	Peak	1.25	175	
7350	32.66	V	54	-21.34	Avg	1.25	175	
9800								No Emission Detected
9800								
12250								No Emission Detected
12250								
14700								No Emission Detected
14700								
17150								No Emission Detected
17150								
19600								No Emission Detected
19600								
22050								No Emission Detected
22050								
24500								No Emission Detected
24500								

FCC 15.249

Universal Electronics, Inc.
 Comcast XR2 RF4CE 2 Device 2013
 Model: URC-4268BC1-XXXX-R

Date: 02/11/2013
 Lab: B
 Tested By: Kyle Fujimoto

**Middle Channel - Antenna 0
 X-Axis**

Freq. (MHz)	Level (dBuV)	Pol (v/h)	Limit	Margin	Peak / QP / Avg	Ant. Height (m)	Table Angle (deg)	Comments
2450	92.16	H	94	-1.84	Peak	1.35	145	
2450	72.16	H	94	-21.84	Avg	1.35	145	
4900	57.21	H	74	-16.79	Peak	1.25	165	
4900	37.21	H	54	-16.79	Avg	1.25	165	
7350	53.25	H	74	-20.75	Peak	1.35	175	
7350	33.25	H	54	-20.75	Avg	1.35	175	
9800								No Emission Detected
9800								
12250								No Emission Detected
12250								
14700								No Emission Detected
14700								
17150								No Emission Detected
17150								
19600								No Emission Detected
19600								
22050								No Emission Detected
22050								
24500								No Emission Detected
24500								

FCC 15.249

Universal Electronics, Inc.
 Comcast XR2 RF4CE 2 Device 2013
 Model: URC-4268BC1-XXXX-R

Date: 02/11/2013
 Lab: B
 Tested By: Kyle Fujimoto

**Middle Channel - Antenna 0
 Y-Axis**

Freq. (MHz)	Level (dBuV)	Pol (v/h)	Limit	Margin	Peak / QP / Avg	Ant. Height (m)	Table Angle (deg)	Comments
2450	92.18	V	94	-1.82	Peak	1.25	155	
2450	72.18	V	94	-21.82	Avg	1.25	155	
4900	56.74	V	74	-17.26	Peak	1.25	155	
4900	36.74	V	54	-17.26	Avg	1.25	155	
7350	54.26	V	74	-19.74	Peak	1.25	165	
7350	34.26	V	54	-19.74	Avg	1.25	165	
9800								No Emission Detected
9800								
12250								No Emission Detected
12250								
14700								No Emission Detected
14700								
17150								No Emission Detected
17150								
19600								No Emission Detected
19600								
22050								No Emission Detected
22050								
24500								No Emission Detected
24500								

FCC 15.249

Universal Electronics, Inc.
 Comcast XR2 RF4CE 2 Device 2013
 Model: URC-4268BC1-XXXX-R

Date: 02/11/2013
 Lab: B
 Tested By: Kyle Fujimoto

**Middle Channel - Antenna 0
 Y-Axis**

Freq. (MHz)	Level (dBuV)	Pol (v/h)	Limit	Margin	Peak / QP / Avg	Ant. Height (m)	Table Angle (deg)	Comments
2450	89.85	H	94	-4.15	Peak	1.25	155	
2450	69.85	H	94	-24.15	Avg	1.25	155	
4900	52.95	H	74	-21.05	Peak	1.35	165	
4900	32.95	H	54	-21.05	Avg	1.35	165	
7350	50.86	H	74	-23.14	Peak	1.25	165	
7350	30.86	H	54	-23.14	Avg	1.25	165	
9800								No Emission Detected
9800								Detected
12250								No Emission Detected
12250								Detected
14700								No Emission Detected
14700								Detected
17150								No Emission Detected
17150								Detected
19600								No Emission Detected
19600								Detected
22050								No Emission Detected
22050								Detected
24500								No Emission Detected
24500								Detected

FCC 15.249

Universal Electronics, Inc.
 Comcast XR2 RF4CE 2 Device 2013
 Model: URC-4268BC1-XXXX-R

Date: 02/11/2013
 Lab: B
 Tested By: Kyle Fujimoto

**Middle Channel - Antenna 0
 Z-Axis**

Freq. (MHz)	Level (dBuV)	Pol (v/h)	Limit	Margin	Peak / QP / Avg	Ant. Height (m)	Table Angle (deg)	Comments
2450	89.21	V	94	-4.79	Peak	1.25	155	
2450	69.21	V	94	-24.79	Avg	1.25	155	
4900	55.08	V	74	-18.92	Peak	1.25	165	
4900	35.08	V	54	-18.92	Avg	1.25	165	
7350	55.26	V	74	-18.74	Peak	1.35	175	
7350	35.26	V	54	-18.74	Avg	1.35	175	
9800								No Emission Detected
9800								
12250								No Emission Detected
12250								
14700								No Emission Detected
14700								
17150								No Emission Detected
17150								
19600								No Emission Detected
19600								
22050								No Emission Detected
22050								
24500								No Emission Detected
24500								

FCC 15.249

Universal Electronics, Inc.
 Comcast XR2 RF4CE 2 Device 2013
 Model: URC-4268BC1-XXXX-R

Date: 02/11/2013
 Lab: B
 Tested By: Kyle Fujimoto

**Middle Channel - Antenna 0
 Z-Axis**

Freq. (MHz)	Level (dBuV)	Pol (v/h)	Limit	Margin	Peak / QP / Avg	Ant. Height (m)	Table Angle (deg)	Comments
2450	92.59	H	94	-1.41	Peak	1.25	155	
2450	72.59	H	94	-21.41	Avg	1.25	155	
4900	53.53	H	74	-20.47	Peak	1.25	165	
4900	33.53	H	54	-20.47	Avg	1.25	165	
7350	52.14	H	74	-21.86	Peak	1.35	175	
7350	32.14	H	54	-21.86	Avg	1.35	175	
9800								No Emission Detected
9800								
12250								No Emission Detected
12250								
14700								No Emission Detected
14700								
17150								No Emission Detected
17150								
19600								No Emission Detected
19600								
22050								No Emission Detected
22050								
24500								No Emission Detected
24500								

FCC 15.249

Universal Electronics, Inc.
 Comcast XR2 RF4CE 2 Device 2013
 Model: URC-4268BC1-XXXX-R

Date: 02/11/2013
 Lab: B
 Tested By: Kyle Fujimoto

**High Channel - Antenna 0
 X-Axis**

Freq. (MHz)	Level (dBuV)	Pol (v/h)	Limit	Margin	Peak / QP / Avg	Ant. Height (m)	Table Angle (deg)	Comments
2475	87.06	V	94	-6.94	Peak	1.25	155	
2475	67.06	V	94	-26.94	Avg	1.25	155	
4950	52.76	V	74	-21.24	Peak	1.35	165	
4950	32.76	V	54	-21.24	Avg	1.35	165	
7425	54.01	V	74	-19.99	Peak	1.25	165	
7425	34.01	V	54	-19.99	Avg	1.25	165	
9900								No Emission Detected
12375								No Emission Detected
14850								No Emission Detected
17325								No Emission Detected
19800								No Emission Detected
22275								No Emission Detected
24750								No Emission Detected

FCC 15.249

Universal Electronics, Inc.
 Comcast XR2 RF4CE 2 Device 2013
 Model: URC-4268BC1-XXXX-R

Date: 02/11/2013
 Lab: B
 Tested By: Kyle Fujimoto

**High Channel - Antenna 0
 X-Axis**

Freq. (MHz)	Level (dBuV)	Pol (v/h)	Limit	Margin	Peak / QP / Avg	Ant. Height (m)	Table Angle (deg)	Comments
2475	92.04	H	94	-1.96	Peak	1.25	155	
2475	72.04	H	94	-21.96	Avg	1.25	155	
4950	53.85	H	74	-20.15	Peak	1.35	165	
4950	33.85	H	54	-20.15	Avg	1.35	165	
7425	55.22	H	74	-18.78	Peak	1.25	165	
7425	35.22	H	54	-18.78	Avg	1.25	165	
9900								No Emission Detected
12375								No Emission Detected
14850								No Emission Detected
17325								No Emission Detected
19800								No Emission Detected
22275								No Emission Detected
24750								No Emission Detected

FCC 15.249

Universal Electronics, Inc.
 Comcast XR2 RF4CE 2 Device 2013
 Model: URC-4268BC1-XXXX-R

Date: 02/11/2013
 Lab: B
 Tested By: Kyle Fujimoto

**High Channel - Antenna 0
 Y-Axis**

Freq. (MHz)	Level (dBuV)	Pol (v/h)	Limit	Margin	Peak / QP / Avg	Ant. Height (m)	Table Angle (deg)	Comments
2475	92.14	V	94	-1.86	Peak	1.25	165	
2475	72.14	V	94	-21.86	Avg	1.25	165	
4950	54.16	V	74	-19.84	Peak	1.35	175	
4950	34.16	V	54	-19.84	Avg	1.35	175	
7425	55.71	V	74	-18.29	Peak	1.25	185	
7425	35.71	V	54	-18.29	Avg	1.25	185	
9900								No Emission Detected
12375								No Emission Detected
14850								No Emission Detected
17325								No Emission Detected
19800								No Emission Detected
22275								No Emission Detected
24750								No Emission Detected

FCC 15.249

Universal Electronics, Inc.
 Comcast XR2 RF4CE 2 Device 2013
 Model: URC-4268BC1-XXXX-R

Date: 02/11/2013
 Lab: B
 Tested By: Kyle Fujimoto

**High Channel - Antenna 0
 Y-Axis**

Freq. (MHz)	Level (dBuV)	Pol (v/h)	Limit	Margin	Peak / QP / Avg	Ant. Height (m)	Table Angle (deg)	Comments
2475	90.61	H	94	-3.39	Peak	1.25	155	
2475	70.61	H	94	-23.39	Avg	1.25	155	
4950	52.59	H	74	-21.41	Peak	1.35	165	
4950	32.59	H	54	-21.41	Avg	1.35	165	
7425	52.01	H	74	-21.99	Peak	1.45	175	
7425	32.01	H	54	-21.99	Avg	1.45	175	
9900								No Emission
9900								Detected
12375								No Emission
12375								Detected
14850								No Emission
14850								Detected
17325								No Emission
17325								Detected
19800								No Emission
19800								Detected
22275								No Emission
22275								Detected
24750								No Emission
24750								Detected

FCC 15.249

Universal Electronics, Inc.
 Comcast XR2 RF4CE 2 Device 2013
 Model: URC-4268BC1-XXXX-R

Date: 02/11/2013
 Lab: B
 Tested By: Kyle Fujimoto

**High Channel - Antenna 0
 Z-Axis**

Freq. (MHz)	Level (dBuV)	Pol (v/h)	Limit	Margin	Peak / QP / Avg	Ant. Height (m)	Table Angle (deg)	Comments
2475	89.31	V	94	-4.69	Peak	1.25	155	
2475	69.31	V	94	-24.69	Avg	1.25	155	
4950	52.11	V	74	-21.89	Peak	1.35	165	
4950	32.11	V	54	-21.89	Avg	1.35	165	
7425	54.03	V	74	-19.97	Peak	1.25	175	
7425	34.03	V	54	-19.97	Avg	1.25	175	
9900								No Emission Detected
9900								
12375								No Emission Detected
12375								
14850								No Emission Detected
14850								
17325								No Emission Detected
17325								
19800								No Emission Detected
19800								
22275								No Emission Detected
22275								
24750								No Emission Detected
24750								

FCC 15.249

Universal Electronics, Inc.
 Comcast XR2 RF4CE 2 Device 2013
 Model: URC-4268BC1-XXXX-R

Date: 02/11/2013
 Lab: B
 Tested By: Kyle Fujimoto

**High Channel - Antenna 0
 Z-Axis**

Freq. (MHz)	Level (dBuV)	Pol (v/h)	Limit	Margin	Peak / QP / Avg	Ant. Height (m)	Table Angle (deg)	Comments
2475	90.46	H	94	-3.54	Peak	1.25	135	
2475	70.46	H	94	-23.54	Avg	1.25	135	
4950	50.43	H	74	-23.57	Peak	1.25	225	
4950	30.43	H	54	-23.57	Avg	1.25	225	
7425	54.57	H	74	-19.43	Peak	1.35	265	
7425	34.57	H	54	-19.43	Avg	1.35	265	
9900								No Emission Detected
9900								
12375								No Emission Detected
12375								
14850								No Emission Detected
14850								
17325								No Emission Detected
17325								
19800								No Emission Detected
19800								
22275								No Emission Detected
22275								
24750								No Emission Detected
24750								

FCC 15.249Universal Electronics, Inc.
Comcast XR2 RF4CE 2 Device 2013
Model: URC-4268BC1-XXXX-RDate: 02/11/2013
Lab: B
Tested By: Kyle Fujimoto**Antenna 0 - Digital Portion and Non-Harmonic Emissions of the EUT
Vertical and Horizontal Polarizations - 1 GHz to 25 GHz**

Freq. (MHz)	Level (dBuV)	Pol (v/h)	Limit	Margin	Peak / QP / Avg	Ant. Height (m)	Table Angle (deg)	Comments
								No Emissions from the Digital Portion from 1 GHz to 25 GHz for the EUT
								No Emissions from the Non-Harmonic Emissions of the EUT from 1 GHz to 25 GHz
								No Emissions Found at the Band Edge at 2400 MHz when the EUT was on the Low Channel
								No Emissions Found at the Band Edge at 2483.5 MHz when the EUT was on the High Channel
								Tested in the X-Axis, Y-Axis, and Z-Axis

FCC 15.249

Universal Electronics, Inc.
 Comcast XR2 RF4CE 2 Device 2013
 Model: URC-4268BC1-XXXX-R

Date: 02/11/2013
 Lab: B
 Tested By: Kyle Fujimoto

**Low Channel - Antenna 1
 X-Axis**

Freq. (MHz)	Level (dBuV)	Pol (v/h)	Limit	Margin	Peak / QP / Avg	Ant. Height (m)	Table Angle (deg)	Comments
2425	83.56	V	94	-10.44	Peak	1.25	155	
2425	63.56	V	94	-30.44	Avg	1.25	155	
4850	46.47	V	74	-27.53	Peak	1.25	155	
4850	26.47	V	54	-27.53	Avg	1.25	155	
7275	50.53	V	74	-23.47	Peak	1.25	165	
7275	30.53	V	54	-23.47	Avg	1.25	165	
9700								No Emission Detected
9700								
12125								No Emission Detected
12125								
14550								No Emission Detected
14550								
16975								No Emission Detected
16975								
19400								No Emission Detected
19400								
21825								No Emission Detected
21825								
24250								No Emission Detected
24250								

FCC 15.249

Universal Electronics, Inc.
 Comcast XR2 RF4CE 2 Device 2013
 Model: URC-4268BC1-XXXX-R

Date: 02/11/2013
 Lab: B
 Tested By: Kyle Fujimoto

**Low Channel - Antenna 1
 X-Axis**

Freq. (MHz)	Level (dBuV)	Pol (v/h)	Limit	Margin	Peak / QP / Avg	Ant. Height (m)	Table Angle (deg)	Comments
2425	96.27	H	94	2.27	Peak	1.25	255	
2425	76.27	H	94	-17.73	Avg	1.25	255	
4850	54.97	H	74	-19.03	Peak	1.35	135	
4850	34.97	H	54	-19.03	Avg	1.35	135	
7275	52.76	H	74	-21.24	Peak	1.25	145	
7275	32.76	H	54	-21.24	Avg	1.25	145	
9700								No Emission Detected
9700								
12125								No Emission Detected
12125								
14550								No Emission Detected
14550								
16975								No Emission Detected
16975								
19400								No Emission Detected
19400								
21825								No Emission Detected
21825								
24250								No Emission Detected
24250								

FCC 15.249

Universal Electronics, Inc.
 Comcast XR2 RF4CE 2 Device 2013
 Model: URC-4268BC1-XXXX-R

Date: 02/11/2013
 Lab: B
 Tested By: Kyle Fujimoto

**Low Channel - Antenna 1
 Y-Axis**

Freq. (MHz)	Level (dBuV)	Pol (v/h)	Limit	Margin	Peak / QP / Avg	Ant. Height (m)	Table Angle (deg)	Comments
2425	95.23	V	94	1.23	Peak	1.25	165	
2425	75.23	V	94	-18.77	Avg	1.25	165	
4850	49.09	V	74	-24.91	Peak	1.35	175	
4850	29.09	V	54	-24.91	Avg	1.35	175	
7275	52.45	V	74	-21.55	Peak	1.25	185	
7275	32.45	V	54	-21.55	Avg	1.25	185	
9700								No Emission Detected
9700								Detected
12125								No Emission Detected
12125								Detected
14550								No Emission Detected
14550								Detected
16975								No Emission Detected
16975								Detected
19400								No Emission Detected
19400								Detected
21825								No Emission Detected
21825								Detected
24250								No Emission Detected
24250								Detected

FCC 15.249

Universal Electronics, Inc.
 Comcast XR2 RF4CE 2 Device 2013
 Model: URC-4268BC1-XXXX-R

Date: 02/11/2013
 Lab: B
 Tested By: Kyle Fujimoto

**Low Channel - Antenna 1
 Y-Axis**

Freq. (MHz)	Level (dBuV)	Pol (v/h)	Limit	Margin	Peak / QP / Avg	Ant. Height (m)	Table Angle (deg)	Comments
2425	86.69	H	94	-7.31	Peak	1.25	225	
2425	66.69	H	94	-27.31	Avg	1.25	225	
4850	50.72	H	74	-23.28	Peak	1.35	45	
4850	30.72	H	54	-23.28	Avg	1.35	45	
7275	53.33	H	74	-20.67	Peak	1.25	145	
7275	33.33	H	54	-20.67	Avg	1.25	145	
9700								No Emission Detected
9700								
12125								No Emission Detected
12125								
14550								No Emission Detected
14550								
16975								No Emission Detected
16975								
19400								No Emission Detected
19400								
21825								No Emission Detected
21825								
24250								No Emission Detected
24250								

FCC 15.249

Universal Electronics, Inc.
 Comcast XR2 RF4CE 2 Device 2013
 Model: URC-4268BC1-XXXX-R

Date: 02/11/2013
 Lab: B
 Tested By: Kyle Fujimoto

**Low Channel - Antenna 1
 Z-Axis**

Freq. (MHz)	Level (dBuV)	Pol (v/h)	Limit	Margin	Peak / QP / Avg	Ant. Height (m)	Table Angle (deg)	Comments
2425	89.62	V	94	-4.38	Peak	1.25	155	
2425	69.62	V	94	-24.38	Avg	1.25	155	
4850	51.59	V	74	-22.41	Peak	1.35	165	
4850	31.59	V	54	-22.41	Avg	1.35	165	
7275	54.21	V	74	-19.79	Peak	1.25	175	
7275	34.21	V	54	-19.79	Avg	1.25	175	
9700								No Emission Detected
9700								
12125								No Emission Detected
12125								
14550								No Emission Detected
14550								
16975								No Emission Detected
16975								
19400								No Emission Detected
19400								
21825								No Emission Detected
21825								
24250								No Emission Detected
24250								

FCC 15.249

Universal Electronics, Inc.
 Comcast XR2 RF4CE 2 Device 2013
 Model: URC-4268BC1-XXXX-R

Date: 02/11/2013
 Lab: B
 Tested By: Kyle Fujimoto

**Low Channel - Antenna 1
 Z-Axis**

Freq. (MHz)	Level (dBuV)	Pol (v/h)	Limit	Margin	Peak / QP / Avg	Ant. Height (m)	Table Angle (deg)	Comments
2425	92.61	H	94	-1.39	Peak	1.25	155	
2425	72.61	H	94	-21.39	Avg	1.25	155	
4850	51.17	H	74	-22.83	Peak	1.35	135	
4850	31.17	H	54	-22.83	Avg	1.35	135	
7275	53.53	H	74	-20.47	Peak	1.25	145	
7275	33.53	H	54	-20.47	Avg	1.25	145	
9700								No Emission Detected
9700								
12125								No Emission Detected
12125								
14550								No Emission Detected
14550								
16975								No Emission Detected
16975								
19400								No Emission Detected
19400								
21825								No Emission Detected
21825								
24250								No Emission Detected
24250								

FCC 15.249

Universal Electronics, Inc.
 Comcast XR2 RF4CE 2 Device 2013
 Model: URC-4268BC1-XXXX-R

Date: 02/11/2013
 Lab: B
 Tested By: Kyle Fujimoto

**Middle Channel - Antenna 1
 X-Axis**

Freq. (MHz)	Level (dBuV)	Pol (v/h)	Limit	Margin	Peak / QP / Avg	Ant. Height (m)	Table Angle (deg)	Comments
2450	81.29	V	94	-12.71	Peak	1.25	225	
2450	61.29	V	94	-32.71	Avg	1.25	225	
4900	50.27	V	74	-23.73	Peak	1.25	165	
4900	30.27	V	54	-23.73	Avg	1.25	165	
7350	54.91	V	74	-19.09	Peak	1.35	175	
7350	34.91	V	54	-19.09	Avg	1.35	175	
9800								No Emission Detected
9800								
12250								No Emission Detected
12250								
14700								No Emission Detected
14700								
17150								No Emission Detected
17150								
19600								No Emission Detected
19600								
22050								No Emission Detected
22050								
24500								No Emission Detected
24500								

FCC 15.249

Universal Electronics, Inc.
 Comcast XR2 RF4CE 2 Device 2013
 Model: URC-4268BC1-XXXX-R

Date: 02/11/2013
 Lab: B
 Tested By: Kyle Fujimoto

**Middle Channel - Antenna 1
 X-Axis**

Freq. (MHz)	Level (dBuV)	Pol (v/h)	Limit	Margin	Peak / QP / Avg	Ant. Height (m)	Table Angle (deg)	Comments
2450	95.84	H	94	1.84	Peak	1.25	135	
2450	75.84	H	94	-18.16	Avg	1.25	135	
4900	48.21	H	74	-25.79	Peak	1.25	145	
4900	28.21	H	54	-25.79	Avg	1.25	145	
7350	50.31	H	74	-23.69	Peak	1.35	165	
7350	30.31	H	54	-23.69	Avg	1.35	165	
9800								No Emission Detected
9800								
12250								No Emission Detected
12250								
14700								No Emission Detected
14700								
17150								No Emission Detected
17150								
19600								No Emission Detected
19600								
22050								No Emission Detected
22050								
24500								No Emission Detected
24500								

FCC 15.249

Universal Electronics, Inc.
 Comcast XR2 RF4CE 2 Device 2013
 Model: URC-4268BC1-XXXX-R

Date: 02/11/2013
 Lab: B
 Tested By: Kyle Fujimoto

**Middle Channel - Antenna 1
 Y-Axis**

Freq. (MHz)	Level (dBuV)	Pol (v/h)	Limit	Margin	Peak / QP / Avg	Ant. Height (m)	Table Angle (deg)	Comments
2450	82.66	V	94	-11.34	Peak	1.25	45	
2450	62.66	V	94	-31.34	Avg	1.25	45	
4900	45.59	V	74	-28.41	Peak	1.35	165	
4900	25.59	V	54	-28.41	Avg	1.35	165	
7350	49.43	V	74	-24.57	Peak	1.25	175	
7350	29.43	V	54	-24.57	Avg	1.25	175	
9800								No Emission Detected
12250								No Emission Detected
14700								No Emission Detected
17150								No Emission Detected
19600								No Emission Detected
22050								No Emission Detected
24500								No Emission Detected

FCC 15.249

Universal Electronics, Inc.
 Comcast XR2 RF4CE 2 Device 2013
 Model: URC-4268BC1-XXXX-R

Date: 02/11/2013
 Lab: B
 Tested By: Kyle Fujimoto

**Middle Channel - Antenna 1
 Y-Axis**

Freq. (MHz)	Level (dBuV)	Pol (v/h)	Limit	Margin	Peak / QP / Avg	Ant. Height (m)	Table Angle (deg)	Comments
2450	86.89	H	94	-7.11	Peak	1.25	155	
2450	66.89	H	94	-27.11	Avg	1.25	155	
4900	46.95	H	74	-27.05	Peak	1.25	175	
4900	26.95	H	54	-27.05	Avg	1.25	175	
7350	50.72	H	74	-23.28	Peak	1.35	185	
7350	30.72	H	54	-23.28	Avg	1.35	185	
9800								No Emission Detected
9800								
12250								No Emission Detected
12250								
14700								No Emission Detected
14700								
17150								No Emission Detected
17150								
19600								No Emission Detected
19600								
22050								No Emission Detected
22050								
24500								No Emission Detected
24500								

FCC 15.249

Universal Electronics, Inc.
 Comcast XR2 RF4CE 2 Device 2013
 Model: URC-4268BC1-XXXX-R

Date: 02/11/2013
 Lab: B
 Tested By: Kyle Fujimoto

**Middle Channel - Antenna 1
 Z-Axis**

Freq. (MHz)	Level (dBuV)	Pol (v/h)	Limit	Margin	Peak / QP / Avg	Ant. Height (m)	Table Angle (deg)	Comments
2450	92.21	V	94	-1.79	Peak	1.25	135	
2450	72.21	V	94	-21.79	Avg	1.25	135	
4900	51.08	V	74	-22.92	Peak	1.35	225	
4900	31.08	V	54	-22.92	Avg	1.35	225	
7350	53.35	V	74	-20.65	Peak	1.45	235	
7350	33.35	V	54	-20.65	Avg	1.45	235	
9800								No Emission Detected
9800								
12250								No Emission Detected
12250								
14700								No Emission Detected
14700								
17150								No Emission Detected
17150								
19600								No Emission Detected
19600								
22050								No Emission Detected
22050								
24500								No Emission Detected
24500								

FCC 15.249

Universal Electronics, Inc.
 Comcast XR2 RF4CE 2 Device 2013
 Model: URC-4268BC1-XXXX-R

Date: 02/11/2013
 Lab: B
 Tested By: Kyle Fujimoto

**Middle Channel - Antenna 1
 Z-Axis**

Freq. (MHz)	Level (dBuV)	Pol (v/h)	Limit	Margin	Peak / QP / Avg	Ant. Height (m)	Table Angle (deg)	Comments
2450	91.26	H	94	-2.74	Peak	1.25	135	
2450	71.26	H	94	-22.74	Avg	1.25	135	
4900	44.18	H	74	-29.82	Peak	1.35	125	
4900	24.18	H	54	-29.82	Avg	1.35	125	
7350	52.06	H	74	-21.94	Peak	1.25	155	
7350	32.06	H	54	-21.94	Avg	1.25	155	
9800								No Emission Detected
9800								Detected
12250								No Emission Detected
12250								Detected
14700								No Emission Detected
14700								Detected
17150								No Emission Detected
17150								Detected
19600								No Emission Detected
19600								Detected
22050								No Emission Detected
22050								Detected
24500								No Emission Detected
24500								Detected

FCC 15.249

Universal Electronics, Inc.
 Comcast XR2 RF4CE 2 Device 2013
 Model: URC-4268BC1-XXXX-R

Date: 02/11/2013
 Lab: B
 Tested By: Kyle Fujimoto

**High Channel - Antenna 1
 X-Axis**

Freq. (MHz)	Level (dBuV)	Pol (v/h)	Limit	Margin	Peak / QP / Avg	Ant. Height (m)	Table Angle (deg)	Comments
2475	85.49	V	94	-8.51	Peak	1.25	165	
2475	65.49	V	94	-28.51	Avg	1.25	165	
4950	43.89	V	74	-30.11	Peak	1.35	175	
4950	23.89	V	54	-30.11	Avg	1.35	175	
7425	48.32	V	74	-25.68	Peak	1.25	185	
7425	28.32	V	54	-25.68	Avg	1.25	185	
9900								No Emission Detected
9900								
12375								No Emission Detected
12375								
14850								No Emission Detected
14850								
17325								No Emission Detected
17325								
19800								No Emission Detected
19800								
22275								No Emission Detected
22275								
24750								No Emission Detected
24750								

FCC 15.249

Universal Electronics, Inc.
 Comcast XR2 RF4CE 2 Device 2013
 Model: URC-4268BC1-XXXX-R

Date: 02/11/2013
 Lab: B
 Tested By: Kyle Fujimoto

**High Channel - Antenna 1
 X-Axis**

Freq. (MHz)	Level (dBuV)	Pol (v/h)	Limit	Margin	Peak / QP / Avg	Ant. Height (m)	Table Angle (deg)	Comments
2475	96.92	H	94	2.92	Peak	1.25	225	
2475	76.92	H	94	-17.08	Avg	1.25	225	
4950	49.21	H	74	-24.79	Peak	1.35	265	
4950	29.21	H	54	-24.79	Avg	1.35	265	
7425	48.57	H	74	-25.43	Peak	1.45	275	
7425	28.57	H	54	-25.43	Avg	1.45	275	
9900								No Emission Detected
9900								
12375								No Emission Detected
12375								
14850								No Emission Detected
14850								
17325								No Emission Detected
17325								
19800								No Emission Detected
19800								
22275								No Emission Detected
22275								
24750								No Emission Detected
24750								

FCC 15.249

Universal Electronics, Inc.
 Comcast XR2 RF4CE 2 Device 2013
 Model: URC-4268BC1-XXXX-R

Date: 02/11/2013
 Lab: B
 Tested By: Kyle Fujimoto

**High Channel - Antenna 1
 Y-Axis**

Freq. (MHz)	Level (dBuV)	Pol (v/h)	Limit	Margin	Peak / QP / Avg	Ant. Height (m)	Table Angle (deg)	Comments
2475	96.43	V	94	2.43	Peak	1.25	155	
2475	76.43	V	94	-17.57	Avg	1.25	155	
4950	47.05	V	74	-26.95	Peak	1.35	165	
4950	27.05	V	54	-26.95	Avg	1.35	165	
7425	51.31	V	74	-22.69	Peak	1.25	155	
7425	31.31	V	54	-22.69	Avg	1.25	155	
9900								No Emission Detected
12375								No Emission Detected
14850								No Emission Detected
17325								No Emission Detected
19800								No Emission Detected
22275								No Emission Detected
24750								No Emission Detected

FCC 15.249

Universal Electronics, Inc.
 Comcast XR2 RF4CE 2 Device 2013
 Model: URC-4268BC1-XXXX-R

Date: 02/11/2013
 Lab: B
 Tested By: Kyle Fujimoto

**High Channel - Antenna 1
 Y-Axis**

Freq. (MHz)	Level (dBuV)	Pol (v/h)	Limit	Margin	Peak / QP / Avg	Ant. Height (m)	Table Angle (deg)	Comments
2475	88.72	H	94	-5.28	Peak	1.25	165	
2475	68.72	H	94	-25.28	Avg	1.25	165	
4950	49.02	H	74	-24.98	Peak	1.25	175	
4950	29.02	H	54	-24.98	Avg	1.25	175	
7425	49.21	H	74	-24.79	Peak	1.35	185	
7425	29.21	H	54	-24.79	Avg	1.35	185	
9900								No Emission Detected
9900								
12375								No Emission Detected
12375								
14850								No Emission Detected
14850								
17325								No Emission Detected
17325								
19800								No Emission Detected
19800								
22275								No Emission Detected
22275								
24750								No Emission Detected
24750								

FCC 15.249

Universal Electronics, Inc.
 Comcast XR2 RF4CE 2 Device 2013
 Model: URC-4268BC1-XXXX-R

Date: 02/11/2013
 Lab: B
 Tested By: Kyle Fujimoto

**High Channel - Antenna 1
 Z-Axis**

Freq. (MHz)	Level (dBuV)	Pol (v/h)	Limit	Margin	Peak / QP / Avg	Ant. Height (m)	Table Angle (deg)	Comments
2475	91.67	V	94	-2.33	Peak	1.25	225	
2475	71.67	V	94	-22.33	Avg	1.25	225	
4950	48.86	V	74	-25.14	Peak	1.35	145	
4950	28.86	V	54	-25.14	Avg	1.35	145	
7425	48.17	V	74	-25.83	Peak	1.25	165	
7425	28.17	V	54	-25.83	Avg	1.25	165	
9900								No Emission Detected
12375								No Emission Detected
14850								No Emission Detected
17325								No Emission Detected
19800								No Emission Detected
22275								No Emission Detected
24750								No Emission Detected

FCC 15.249

Universal Electronics, Inc.
 Comcast XR2 RF4CE 2 Device 2013
 Model: URC-4268BC1-XXXX-R

Date: 02/11/2013
 Lab: B
 Tested By: Kyle Fujimoto

**High Channel - Antenna 1
 Z-Axis**

Freq. (MHz)	Level (dBuV)	Pol (v/h)	Limit	Margin	Peak / QP / Avg	Ant. Height (m)	Table Angle (deg)	Comments
2475	92.45	H	94	-1.55	Peak	1.25	0	
2475	72.45	H	94	-21.55	Avg	1.25	0	
4950	47.62	H	74	-26.38	Peak	1.35	125	
4950	27.62	H	54	-26.38	Avg	1.35	125	
7425	50.39	H	74	-23.61	Peak	1.25	145	
7425	30.39	H	54	-23.61	Avg	1.25	145	
9900								No Emission Detected
9900								Detected
12375								No Emission Detected
12375								Detected
14850								No Emission Detected
14850								Detected
17325								No Emission Detected
17325								Detected
19800								No Emission Detected
19800								Detected
22275								No Emission Detected
22275								Detected
24750								No Emission Detected
24750								Detected

FCC 15.249

Universal Electronics, Inc.
 Comcast XR2 RF4CE 2 Device 2013
 Model: URC-4268BC1-XXXX-R

Date: 02/11/2013
 Lab: B
 Tested By: Kyle Fujimoto

**Antenna 1 - Digital Portion and Non-Harmonic Emissions of the EUT
 Vertical and Horizontal Polarizations - 1 GHz to 25 GHz**

Freq. (MHz)	Level (dBuV)	Pol (v/h)	Limit	Margin	Peak / QP / Avg	Ant. Height (m)	Table Angle (deg)	Comments
								No Emissions from the Digital Portion from 1 GHz to 25 GHz for the EUT
								No Emissions from the Non-Harmonic Emissions of the EUT from 1 GHz to 25 GHz
								No Emissions Found at the Band Edge at 2400 MHz when the EUT was on the Low Channel
								No Emissions Found at the Band Edge at 2483.5 MHz when the EUT was on the High Channel
								Tested in the X-Axis, Y-Axis, and Z-Axis

FCC 15.249

Universal Electronics, Inc.
 Comcast XR2 RF4CE 2 Device 2013
 Model: URC-4268BC1-XXXX-R

Date: 02/19/2013
 Lab: D
 Tested By: Alex Benitez

**Antenna 1 - Digital Portion and Non-Harmonic Emissions of the EUT
 Vertical and Horizontal Polarizations - 10 kHz to 1000 MHz**

Freq. (MHz)	Level (dBuV)	Pol (v/h)	Limit	Margin	Peak / QP / Avg	Ant. Height (m)	Table Angle (deg)	Comments
								No Emissions from the Digital Portion from 10 kHz to 1000 MHz for the EUT
								No Emissions from the Non-Harmonic Emissions of the EUT from 10 kHz to 1000 MHz
								Tested in the X-Axis, Y-Axis, and Z-Axis