

**Calibration Laboratory of
Schmid & Partner
Engineering AG**
Zeughausstrasse 43, 8004 Zurich, Switzerland

Client [REDACTED]

CALIBRATION CERTIFICATE

Object(s) DAE3 - SN:558

Calibration procedure(s) QA CAL-06 v2
Calibration procedure for the data acquisition unit (DAE)

Calibration date: March 07, 2003

Condition of the calibrated item In Tolerance (according to the specific calibration document)

This calibration statement documents traceability of M&TE used in the calibration procedures and conformity of the procedures with the ISO/IEC 17025 international standard.

All calibrations have been conducted in the closed laboratory facility; environment temperature 22 +/- 2 degrees Celsius and humidity < 75%.

Calibration Equipment used (M&TE critical for calibration)

Model Type	ID #	Cal Date	Scheduled Calibration
Fluke Process Calibrator Type 702	SN: 6295803	3-Sep-01	Sep-03

	Name	Function	Signature
Calibrated by:	Eric Hainfeld	Technician	[Signature]
Approved by:	Fin Bornhoff	R&D Director	[Signature]

Date issued: March 07, 2003

This calibration certificate is issued as an intermediate solution until the accreditation process (based on ISO/IEC 17025 international Standard) for Calibration Laboratory of Schmid & Partner Engineering AG is completed.

1. DC Voltage Measurement

DA - Converter Values from DAE

High Range: 1LSB = 6.1 μ V, full range = 400 mV
 Low Range: 1LSB = 61nV, full range = 4 mV

Software Set-up: Calibration time: 3 sec Measuring time: 3 sec

Setup	X	Y	Z
High Range	405.010098	404.9037428	405.0817835
Low Range	3.972	3.95185	3.96828
Connector Position	86 °		

High Range	Input	Reading in μ V	% Error
Channel X + Input	200mV	200000	0.00
	20mV	20003.4	0.02
Channel X - Input	20mV	-19993	-0.04
	200mV	200001	0.00
Channel Y + Input	20mV	20002.7	0.01
	20mV	-19993	-0.04
Channel Y - Input	20mV	-19993	-0.04
	200mV	200000	0.00
Channel Z + Input	20mV	20000.8	0.00
	20mV	-19997.7	-0.01
Channel Z - Input	20mV	-19997.7	-0.01

Low Range	Input	Reading in μ V	% Error
Channel X + Input	2mV	2000.2	0.01
	0.2mV	200.04	0.02
Channel X - Input	0.2mV	-200.81	0.41
	2mV	2000.1	0.00
Channel Y + Input	0.2mV	199.47	-0.27
	0.2mV	-201.01	0.50
Channel Y - Input	0.2mV	-201.01	0.50
	2mV	1999.9	0.00
Channel Z + Input	0.2mV	198.68	-0.66
	0.2mV	-201.1	0.55
Channel Z - Input	0.2mV	-201.1	0.55

2. Common mode sensitivity

Software Set-up

Calibration time: 3 sec, Measuring time: 3 sec

High/Low Range

in μV	Common mode Input Voltage	High Range Reading	Low Range Reading
Channel X	200mV	-1.0284	-1.5716
	- 200mV	3.9204	1.3725
Channel Y	200mV	6.7686	5.874
	- 200mV	-6.8145	-8.0898
Channel Z	200mV	2.1943	2.766
	- 200mV	-2.52	-4.6218

3. Channel separation

Software Set-up

Calibration time: 3 sec, Measuring time: 3 sec

High Range

in μV	Input Voltage	Channel X	Channel Y	Channel Z
Channel X	200mV	-	0.88082	0.19177
Channel Y	200mV	0.049124	-	0.25676
Channel Z	200mV	-2.1226	-0.89508	-

4. AD-Converter Values with inputs shorted

in LSB	Low Range	High Range
Channel X	16492	16236
Channel Y	16307	15690
Channel Z	16461	16033

5. Input Offset Measurement

Measured after 15 min warm-up time of the Data Acquisition Electronic.
Every Measurement is preceded by a calibration cycle.

Software set-up:

Calibration time: 3 sec
Measuring time: 3 sec
Number of measurements: 100, Low Range

Input 10M Ω

in μV	Average	min. Offset	max. Offset	Std. Deviation
Channel X	-0.52	-1.64	0.60	0.43
Channel Y	-2.05	-3.65	0.06	0.51
Channel Z	-0.34	-2.05	0.43	0.37

Input shorted

in μV	Average	min. Offset	max. Offset	Std. Deviation
Channel X	0.04	-0.84	1.09	0.41
Channel Y	-0.77	-2.08	0.17	0.40
Channel Z	-1.01	-1.68	-0.38	0.24

6. Input Offset Current

in fA	Input Offset Current
Channel X	< 25
Channel Y	< 25
Channel Z	< 25

7. Input Resistance

	Calibrating	Measuring
Channel X	200 k Ω	200 M Ω
Channel Y	200 k Ω	200 M Ω
Channel Z	200 k Ω	200 M Ω

8. Low Battery Alarm Voltage

in V	Alarm Level
Supply (+ Vcc)	7.66 V
Supply (- Vcc)	-7.53 V

9. Power Consumption

in mA	Switched off	Stand by	Transmitting
Supply (+ Vcc)	0.000	5.83	14.1
Supply (- Vcc)	-0.011	-7.86	-9.13

10. Functional test

Touch async pulse 1	ok
Touch async pulse 2	ok
Touch status bit 1	ok
Touch status bit 2	ok
Remote power off	ok
Remote analog Power control	ok
Modification Status	B – C

Client **C&C (Auden)**

CALIBRATION CERTIFICATE

Object(s) **ET3DV6 - SN:1762**

Calibration procedure(s) **QA CAL-01.v2
 Calibration procedure for dosimetric E-field probes**

Calibration date: **March 31, 2003**

Condition of the calibrated item **In Tolerance (according to the specific calibration document)**

This calibration statement documents traceability of M&TE used in the calibration procedures and conformity of the procedures with the ISO/IEC 17025 international standard.

All calibrations have been conducted in the closed laboratory facility: environment temperature 22 +/- 2 degrees Celsius and humidity < 75%.

Calibration Equipment used (M&TE critical for calibration)

Model Type	ID #	Cal Date	Scheduled Calibration
RF generator HP 8684C	US3642U01700	4-Aug-99 (in house check Aug-02)	In house check: Aug-05
Power sensor E4412A	MY41495277	Mar-02	Mar-03
Power sensor HP 8481A	MY41092180	18-Sep-02	Sep-03
Power meter EPM E4419B	GB41293874	13-Sep-02	Sep-03
Network Analyzer HP 8753E	US38432426	3-May-00	In house check: May 03
Flyuke Process Calibrator Type 702	SN: 6295803	3-Sep-01	Sep-03

Calibrated by: **Name: Nico Veltrop, Function: Technician, Signature: [Handwritten Signature]**

Approved by: **Name: Katja Pokovic, Function: Laboratory Director, Signature: [Handwritten Signature]**

Date issued: April 2, 2003

This calibration certificate is issued as an intermediate solution until the accreditation process (based on ISO/IEC 17025 International Standard) for Calibration Laboratory of Schmid & Partner Engineering AG is completed.

Probe ET3DV6

SN:1762

Manufactured: January 20, 2003
Last calibration: March 31, 2003

Calibrated for DASY Systems

(Note: non-compatible with DASY2 system!)

DASY - Parameters of Probe: ET3DV6 SN:1762**Sensitivity in Free Space**

NormX	1.90 $\mu\text{V}/(\text{V}/\text{m})^2$
NormY	1.78 $\mu\text{V}/(\text{V}/\text{m})^2$
NormZ	1.82 $\mu\text{V}/(\text{V}/\text{m})^2$

Diode Compression

DCP X	96	mV
DCP Y	96	mV
DCP Z	96	mV

Sensitivity in Tissue Simulating Liquid

Head	900 MHz	$\epsilon_r = 41.5 \pm 5\%$	$\sigma = 0.97 \pm 5\%$ mho/m
Head	835 MHz	$\epsilon_r = 41.5 \pm 5\%$	$\sigma = 0.90 \pm 5\%$ mho/m
ConvF X	6.7 $\pm 9.5\%$ (k=2)		Boundary effect:
ConvF Y	6.7 $\pm 9.5\%$ (k=2)		Alpha 0.67
ConvF Z	6.7 $\pm 9.5\%$ (k=2)		Depth 1.74
Head	1800 MHz	$\epsilon_r = 40.0 \pm 5\%$	$\sigma = 1.40 \pm 5\%$ mho/m
Head	1900 MHz	$\epsilon_r = 40.0 \pm 5\%$	$\sigma = 1.40 \pm 5\%$ mho/m
ConvF X	5.4 $\pm 9.5\%$ (k=2)		Boundary effect:
ConvF Y	5.4 $\pm 9.5\%$ (k=2)		Alpha 0.50
ConvF Z	5.4 $\pm 9.5\%$ (k=2)		Depth 2.63

Boundary Effect

Head	900 MHz	Typical SAR gradient: 5 % per mm	
	Probe Tip to Boundary	1 mm	2 mm
	SAR _{be} [%] Without Correction Algorithm	8.8	4.5
	SAR _{be} [%] With Correction Algorithm	0.1	0.2
Head	1800 MHz	Typical SAR gradient: 10 % per mm	
	Probe Tip to Boundary	1 mm	2 mm
	SAR _{be} [%] Without Correction Algorithm	13.8	9.3
	SAR _{be} [%] With Correction Algorithm	0.2	0.1

Sensor Offset

Probe Tip to Sensor Center	2.7	mm
Optical Surface Detection	1.4 \pm 0.2	mm

Receiving Pattern (ϕ), $\theta = 0^\circ$

f = 30 MHz, TEM cell if110

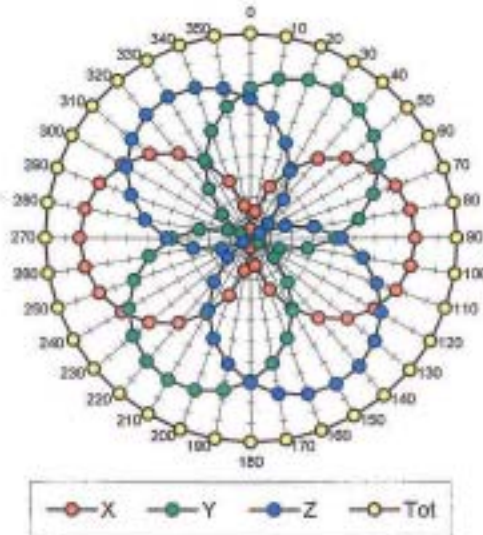

f = 100 MHz, TEM cell if110

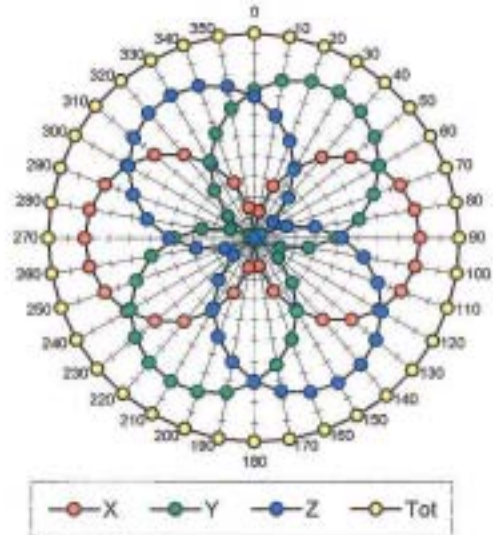

f = 300 MHz, TEM cell if110

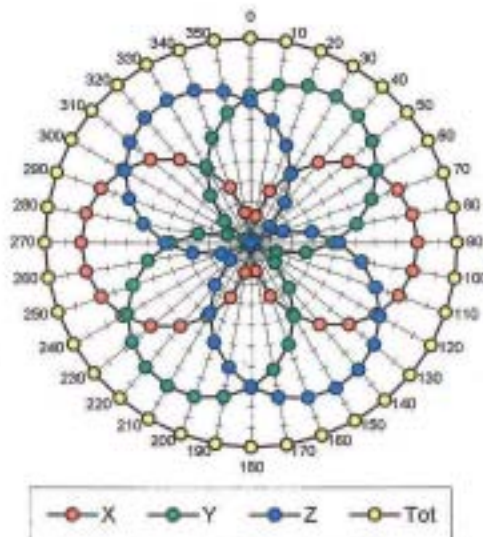

f = 900 MHz, TEM cell if110

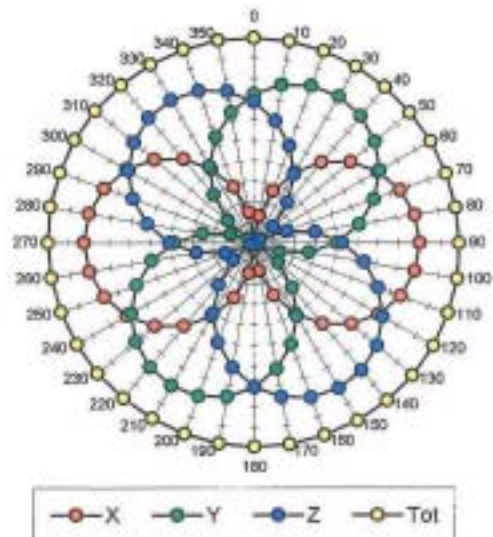

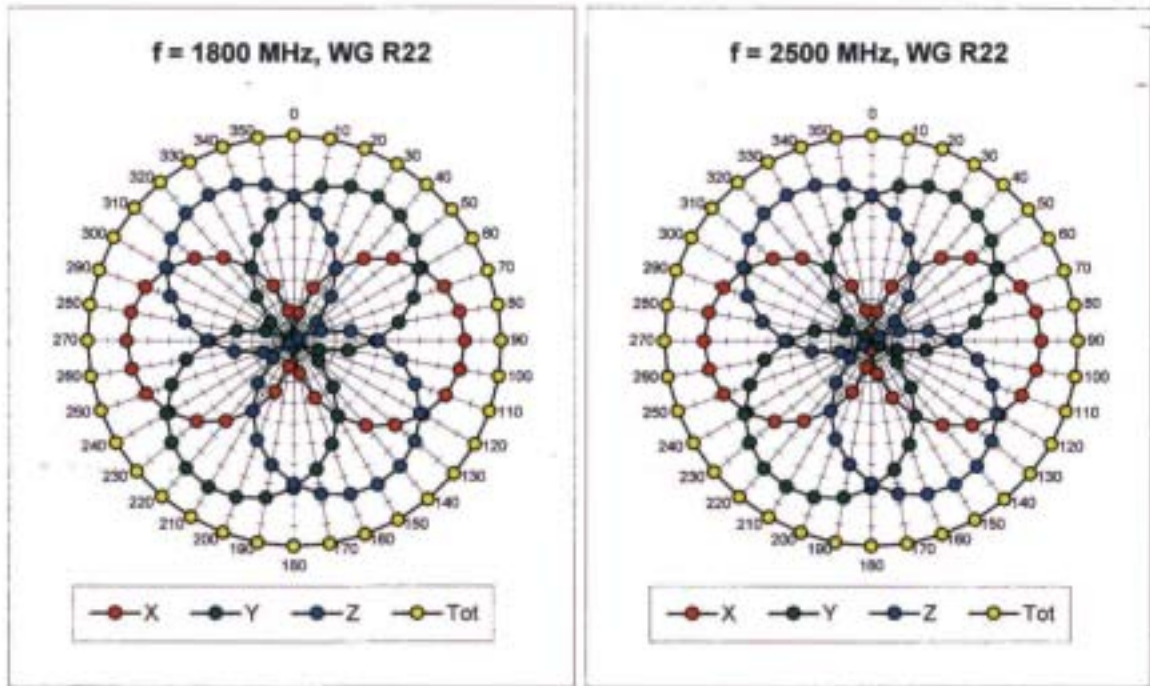

Isotropy Error (ϕ), $\theta = 0^\circ$

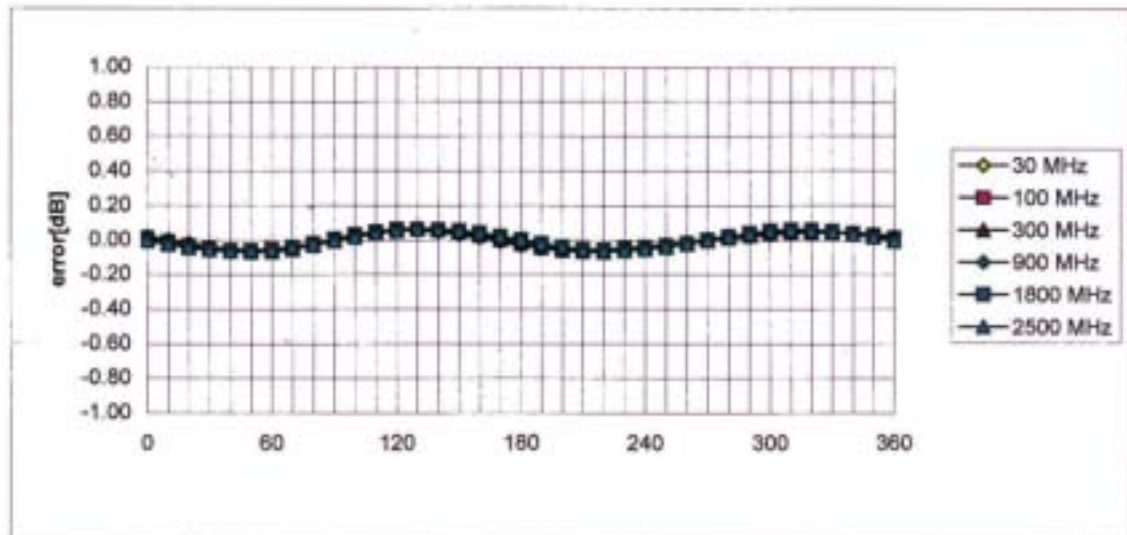

Frequency Response of E-Field

(TEM-Cell:ifi110, Waveguide R22)

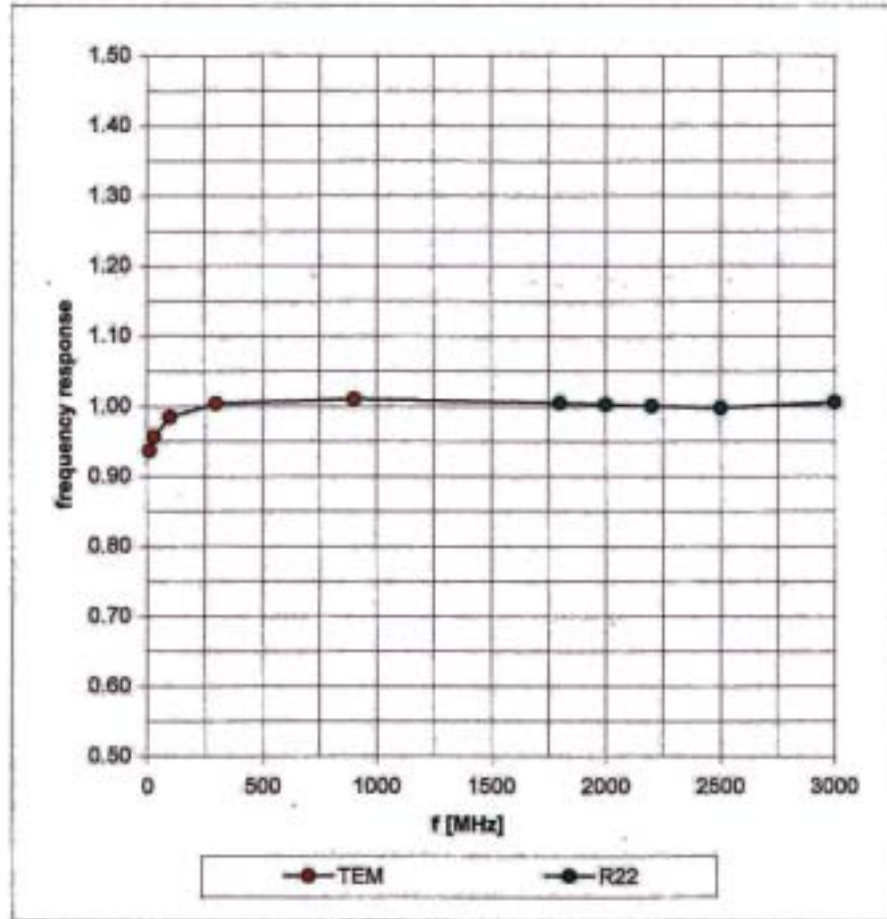

Dynamic Range f(SAR_{brain}) (Waveguide R22)

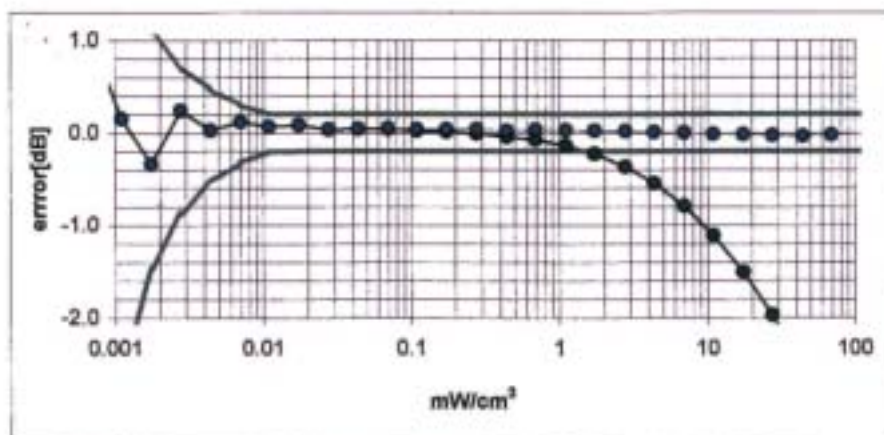
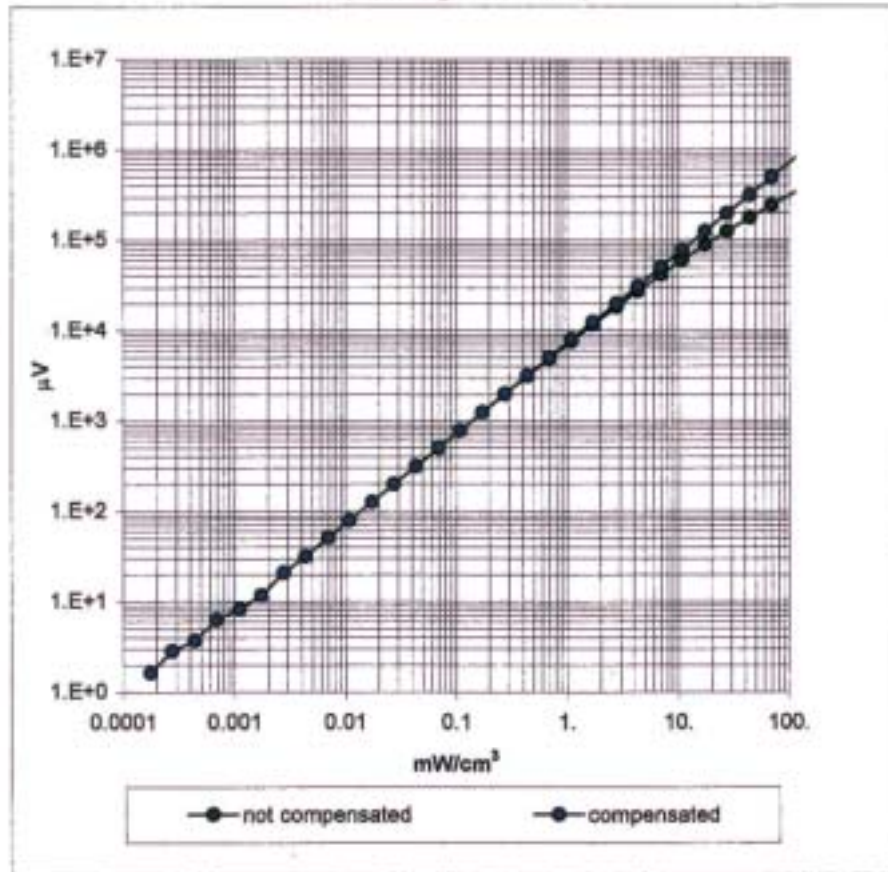

Conversion Factor Assessment

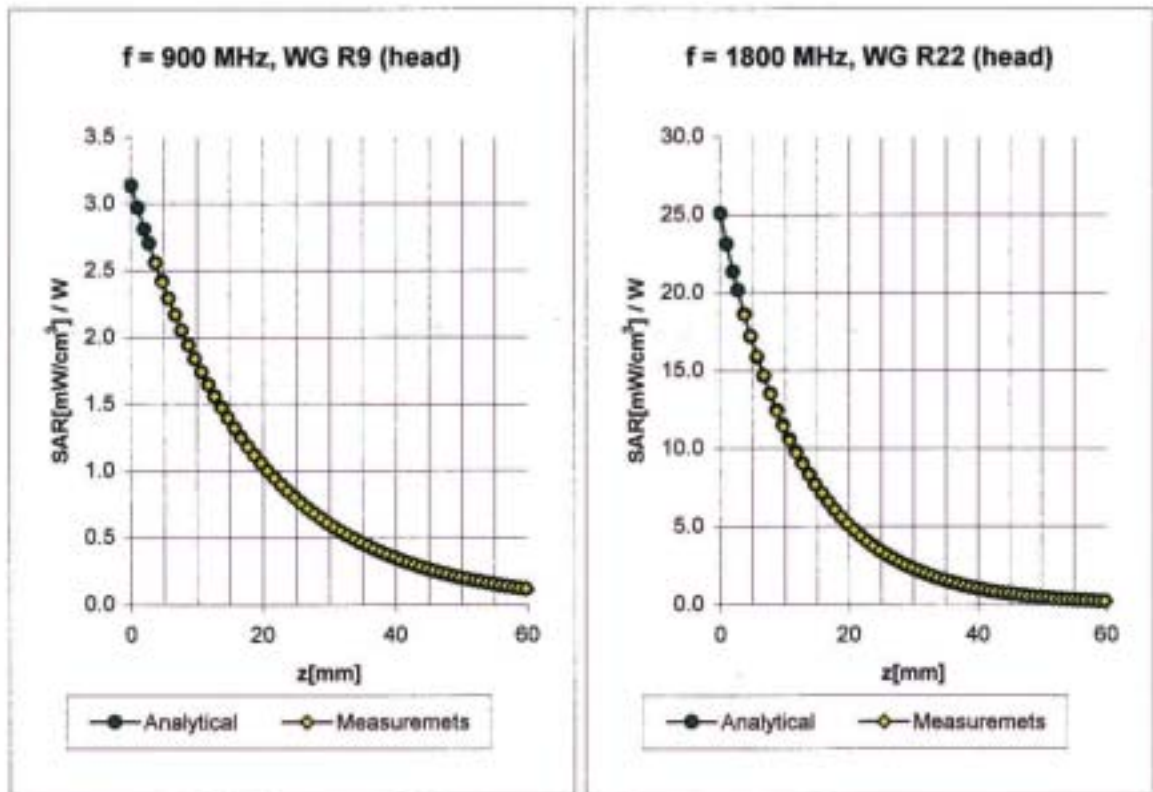

Head	900 MHz	$\epsilon_r = 41.5 \pm 5\%$	$\sigma = 0.97 \pm 5\%$ mho/m
Head	835 MHz	$\epsilon_r = 41.5 \pm 5\%$	$\sigma = 0.90 \pm 5\%$ mho/m
	ConvF X	6.7 $\pm 9.5\%$ (k=2)	Boundary effect:
	ConvF Y	6.7 $\pm 9.5\%$ (k=2)	Alpha 0.67
	ConvF Z	6.7 $\pm 9.5\%$ (k=2)	Depth 1.74
Head	1800 MHz	$\epsilon_r = 40.0 \pm 5\%$	$\sigma = 1.40 \pm 5\%$ mho/m
Head	1900 MHz	$\epsilon_r = 40.0 \pm 5\%$	$\sigma = 1.40 \pm 5\%$ mho/m
	ConvF X	5.4 $\pm 9.5\%$ (k=2)	Boundary effect:
	ConvF Y	5.4 $\pm 9.5\%$ (k=2)	Alpha 0.50
	ConvF Z	5.4 $\pm 9.5\%$ (k=2)	Depth 2.63

Conversion Factor Assessment

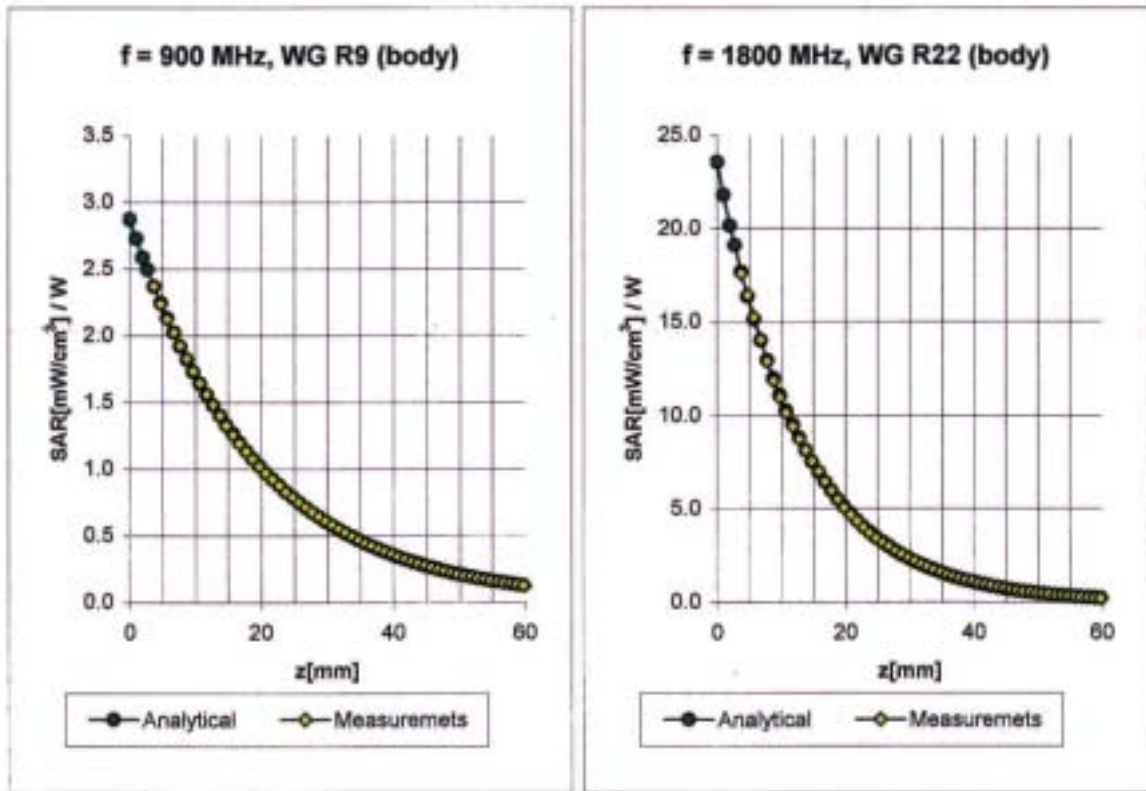

Body	900 MHz	$\epsilon_r = 55.0 \pm 5\%$	$\sigma = 1.05 \pm 5\% \text{ mho/m}$
Body	835 MHz	$\epsilon_r = 55.2 \pm 5\%$	$\sigma = 0.97 \pm 5\% \text{ mho/m}$
	ConvF X	6.5 $\pm 9.5\%$ (k=2)	Boundary effect:
	ConvF Y	6.5 $\pm 9.5\%$ (k=2)	Alpha 0.43
	ConvF Z	6.5 $\pm 9.5\%$ (k=2)	Depth 2.34
Body	1800 MHz	$\epsilon_r = 53.3 \pm 5\%$	$\sigma = 1.52 \pm 5\% \text{ mho/m}$
Body	1900 MHz	$\epsilon_r = 53.3 \pm 5\%$	$\sigma = 1.52 \pm 5\% \text{ mho/m}$
	ConvF X	5.0 $\pm 9.5\%$ (k=2)	Boundary effect:
	ConvF Y	5.0 $\pm 9.5\%$ (k=2)	Alpha 0.57
	ConvF Z	5.0 $\pm 9.5\%$ (k=2)	Depth 2.65

Conversion Factor Assessment

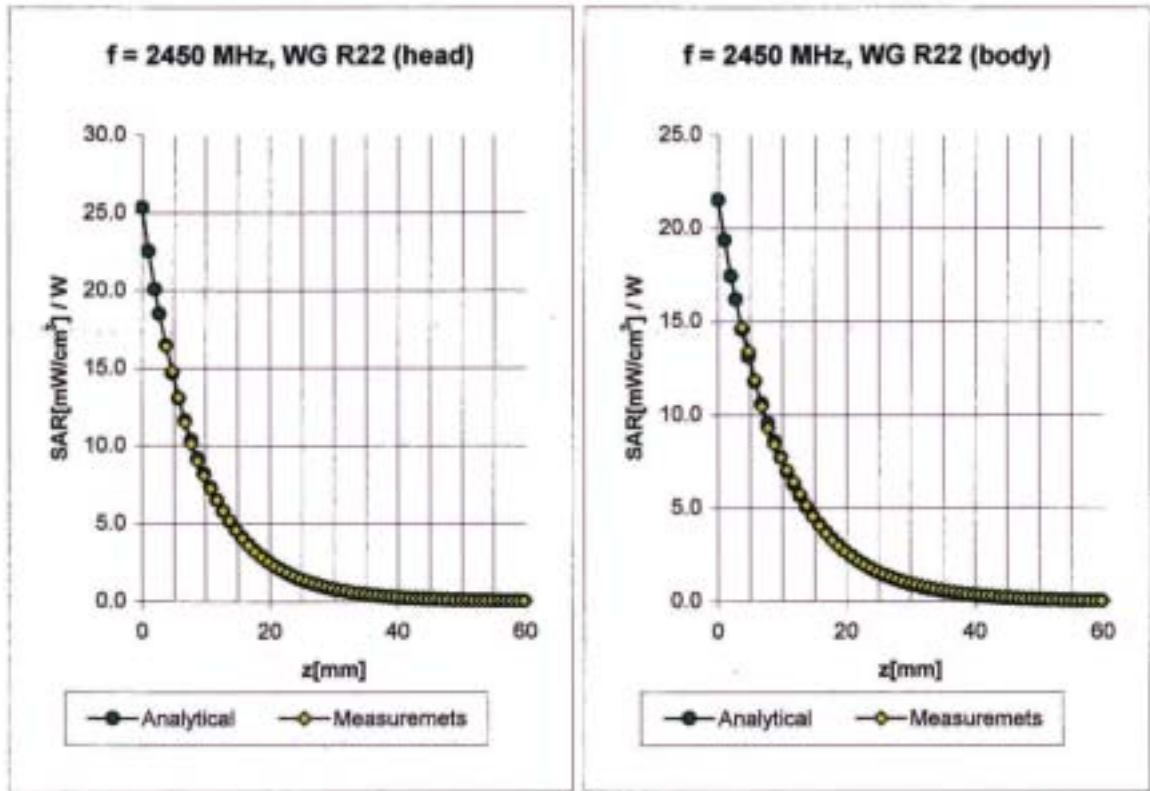

Head	2450	MHz	$\epsilon_r = 39.2 \pm 5\%$	$\sigma = 1.80 \pm 5\%$ mho/m
	ConvF X		5.1 $\pm 8.9\%$ (k=2)	Boundary effect:
	ConvF Y		5.1 $\pm 8.9\%$ (k=2)	Alpha 1.32
	ConvF Z		5.1 $\pm 8.9\%$ (k=2)	Depth 1.61
Body	2450	MHz	$\epsilon_r = 52.7 \pm 5\%$	$\sigma = 1.95 \pm 5\%$ mho/m
	ConvF X		4.6 $\pm 8.9\%$ (k=2)	Boundary effect:
	ConvF Y		4.6 $\pm 8.9\%$ (k=2)	Alpha 1.39
	ConvF Z		4.6 $\pm 8.9\%$ (k=2)	Depth 1.60

Deviation from Isotropy in HSL

Error (θ, ϕ), $f = 900$ MHz

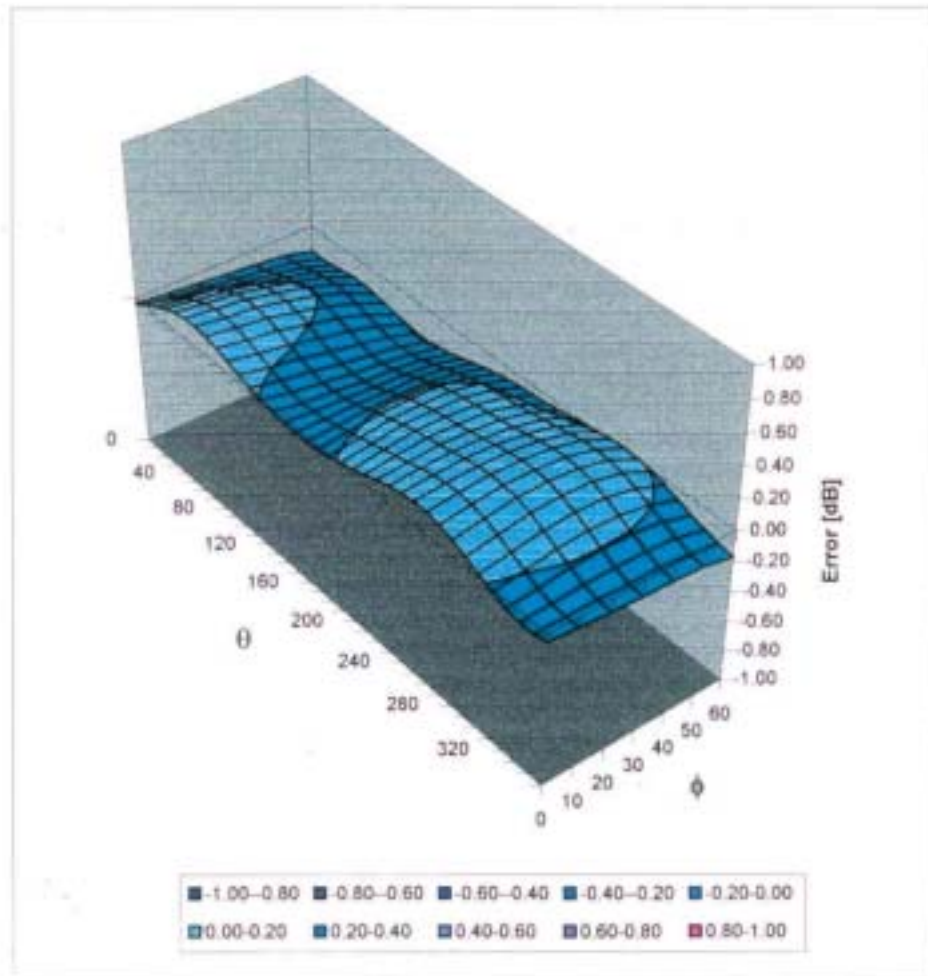

Client **C&C (Auden)**

CALIBRATION CERTIFICATE

Object(s) **D2450V2 - SN:728**

Calibration procedure(s) **QA CAL-05.v2
Calibration procedure for dipole validation kits**

Calibration date: **March 5, 2003**



Condition of the calibrated item **In Tolerance (according to the specific calibration document)**

This calibration statement documents traceability of M&TE used in the calibration procedures and conformity of the procedures with the ISO/IEC 17025 international standard.

All calibrations have been conducted in the closed laboratory facility: environment temperature 22 +/- 2 degrees Celsius and humidity < 75%.

Calibration Equipment used (M&TE critical for calibration)

Model Type	ID #	Cal Date	Scheduled Calibration
RF generator R&S SML-03	100698	27-Mar-2002	In house check: Mar-05
Power sensor HP 8481A	MY41092317	18-Oct-02	Oct-04
Power sensor HP 8481A	US37292783	30-Oct-02	Oct-03
Power meter EPM E442	GB37480704	30-Oct-02	Oct-03
Network Analyzer HP 8753E	US38432426	3-May-00	In house check: May 03

	Name	Function	Signature
Calibrated by:	Nico Vetterli	Technician	
Approved by:	Katja Pokovic	Laboratory Director	

Date issued: April 2, 2003

This calibration certificate is issued as an intermediate solution until the accreditation process (based on ISO/IEC 17025 International Standard) for Calibration Laboratory of Schmid & Partner Engineering AG is completed.

DASY

Dipole Validation Kit

Type: D2450V2

Serial: 728

Manufactured: January 9, 2003

Calibrated: March 5, 2003

1. Measurement Conditions

The measurements were performed in the flat section of the SAM twin phantom filled with head simulating solution of the following electrical parameters at 2450 MHz:

Relative Dielectricity	37.4	$\pm 5\%$
Conductivity	1.88 mho/m	$\pm 5\%$

The DASY4 System with a dosimetric E-field probe ES3DV2 (SN:3013, Conversion factor 4.8 at 2450 MHz) was used for the measurements.

The dipole was mounted on the small tripod so that the dipole feedpoint was positioned below the center marking of the flat phantom section and the dipole was oriented parallel to the body axis (the long side of the phantom). The standard measuring distance was 10mm from dipole center to the solution surface. The included distance holder was used during measurements for accurate distance positioning.

The coarse grid with a grid spacing of 15mm was aligned with the dipole. The 7x7x7 fine cube was chosen for cube integration.

The dipole input power (forward power) was $250\text{mW} \pm 3\%$. The results are normalized to 1W input power.

2. SAR Measurement with DASY4 System

Standard SAR-measurements were performed according to the measurement conditions described in section 1. The results (see figure supplied) have been normalized to a dipole input power of 1W (forward power). The resulting averaged SAR-values measured with the dosimetric probe ES3DV2 SN:3013 and applying the advanced extrapolation are:

averaged over 1 cm^3 (1 g) of tissue:	54.8 mW/g $\pm 16.8\%$ $(k=2)^{\dagger}$
averaged over 10 cm^3 (10 g) of tissue:	24.2 mW/g $\pm 16.2\%$ $(k=2)^{\dagger}$

[†] validation uncertainty

Date/Time: 03/05/03 12:24:05

Test Laboratory: SPEAG, Zurich, Switzerland
File Name: SN728_SN3013_HSL2450_050303.da4

DUT: Dipole 2450 MHz; Serial: D2450V2 - SN728
Program: Dipole Calibration

Communication System: CW-2450; Frequency: 2450 MHz; Duty Cycle: 1:1
Medium: HSL 2450 MHz; ($\sigma = 1.88 \text{ mho/m}$, $\epsilon_r = 37.4$, $\rho = 1000 \text{ kg/m}^3$)
Phantom section: Flat Section

DASY4 Configuration:

- Probe: ES3DV2 - SN3013; ConvF(4.8, 4.8, 4.8); Calibrated: 1/19/2003
- Sensor-Surface: 4mm (Mechanical Surface Detection)
- Electronics: DAE3 - SN411; Calibrated: 1/16/2003
- Phantom: SAM with CRP - TP1006; Type: SAM 4.0; Serial: TP:1006
- Measurement SW: DASY4, V4.1 Build 25; Postprocessing SW: SEMCAD, V1.6 Build 105

Pin = 250 mW; d = 10 mm/Area Scan (81x81x1): Measurement grid: dx=15mm, dy=15mm
Pin = 250 mW; d = 10 mm/Zoom Scan (7x7x7)/Cube 0: Measurement grid: dx=5mm, dy=5mm, dz=5mm
Reference Value = 91.6 V/m
Peak SAR = 30.6 W/kg
SAR(1 g) = 13.7 mW/g; SAR(10 g) = 6.04 mW/g
Power Drift = 0.02 dB

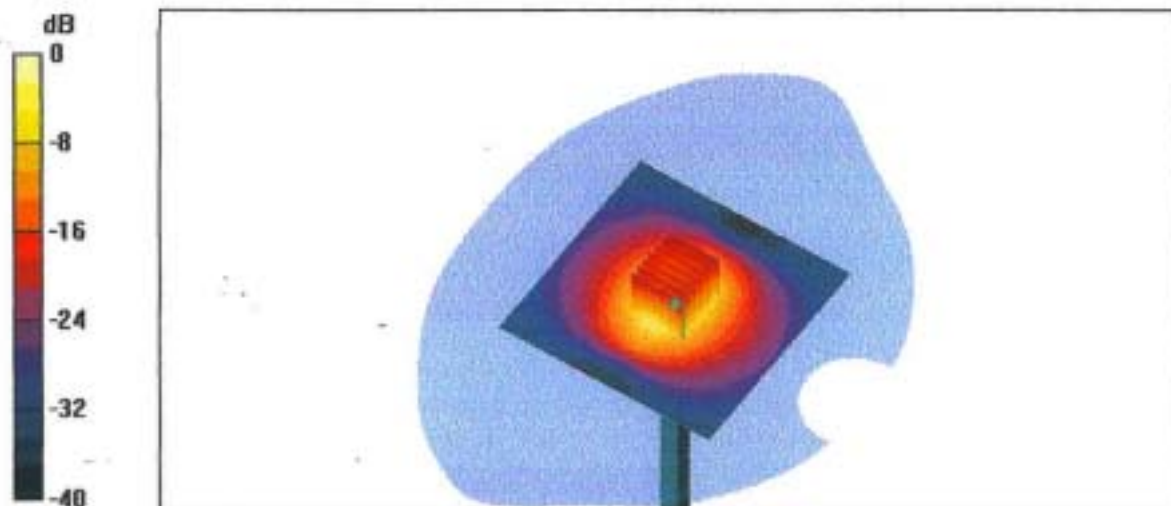

CH1 S11 1 U F9

f: 53.662 a 3.8359 a 249.19 pHz

5 Mar 2003 18:02:21

2 450.000 000 MHz

728
Head

De1

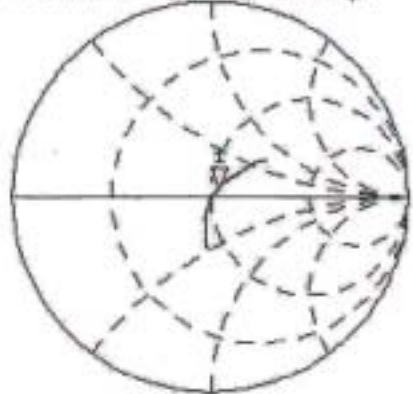

PRn
Cor
Avg
16

CH2 S11 LOG

5 dB/REF 0 dB

f: -25.078 dB 2 450.000 000 MHz

PRn
Cor

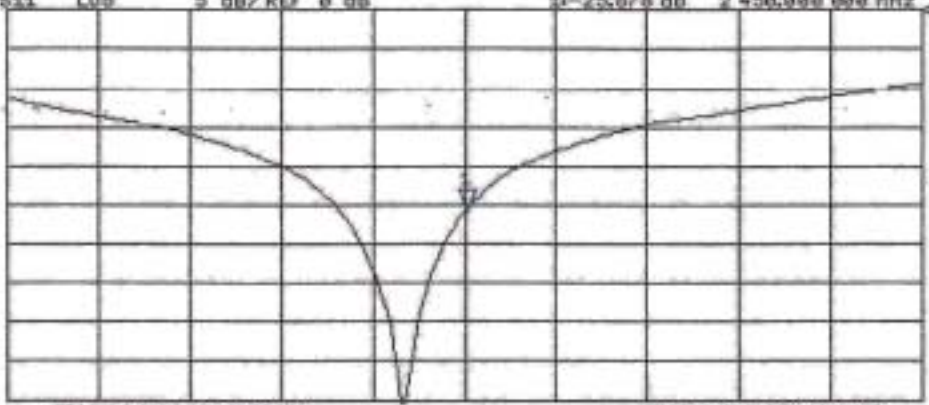

START 2 250.000 000 MHz

STOP 2 650.000 000 MHz

Test Laboratory: Compliance Certification Services Inc.

D2450V2 SN 728

DUT: Dipole 2450 MHz; Type: D2450V2; Serial: 728

Communication System: CW2450; Frequency: 2450 MHz; Duty Cycle: 1:1

Medium: HSL2450 ($\sigma = 1.85$ mho/m, $\epsilon_r = 39$, $\rho = 1000$ kg/m³)

Air Temperature 25.3 deg C ; Liquid Temperature 24.3 deg C

Phantom section: Flat Section

DASY4 Configuration:

- Probe: ET3DV6 - SN1762; ConvF(5.1, 5.1, 5.1); Calibrated: 3/31/2003
- Sensor-Surface: 4mm (Mechanical Surface Detection)
Sensor-Surface: 0mm (Fix Surface)
Sensor-Surface: 4mm (Mechanical And Optical Surface Detection)
- Electronics: DAE3 Sn558; Calibrated: 3/7/2003
- Phantom: SAM 12; Type: SAM V4.0; Serial: TP-1271
- Measurement SW: DASY4, V4.1 Build 47; Postprocessing SW: SEMCAD, V1.8 Build 62

Pin=250mW,d=10mm/Area Scan (6x6x1): Measurement grid: dx=15mm, dy=15mm

Reference Value = 95.1 V/m

Power Drift = 0.1 dB

Maximum value of SAR = 10.8 mW/g

Pin=250mW,d=10mm/Z Scan (1x1x21): Measurement grid: dx=20mm, dy=20mm, dz=5mm

Reference Value = 95.1 V/m

Power Drift = 0.1 dB

Maximum value of SAR = 19.8 mW/g

Pin=250mW,d=10mm/Zoom Scan (5x5x7)/Cube 0: Measurement grid: dx=7.5mm, dy=7.5mm, dz=5mm

Peak SAR (extrapolated) = 29.1 W/kg

SAR(1 g) = 13.6 mW/g; SAR(10 g) = 6.3 mW/g

Reference Value = 95.1 V/m

Power Drift = 0.1 dB

Maximum value of SAR = 15.4 mW/g

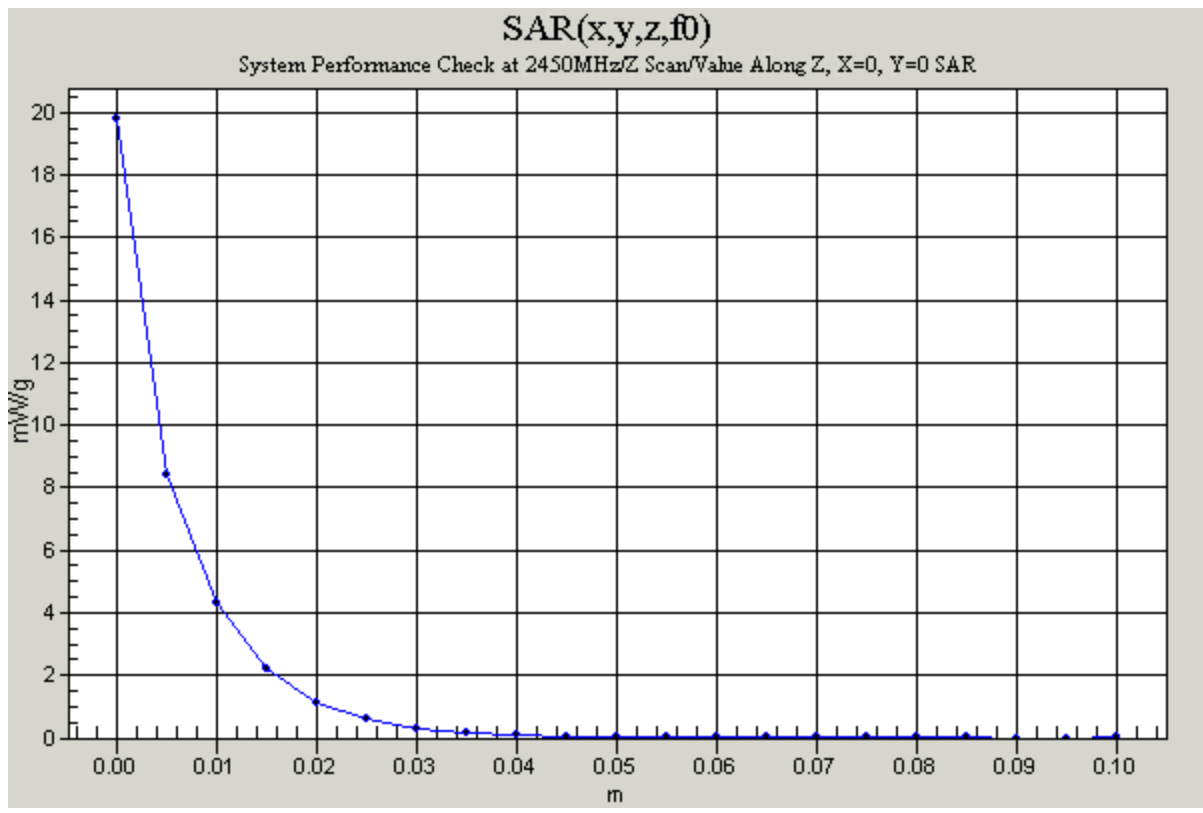
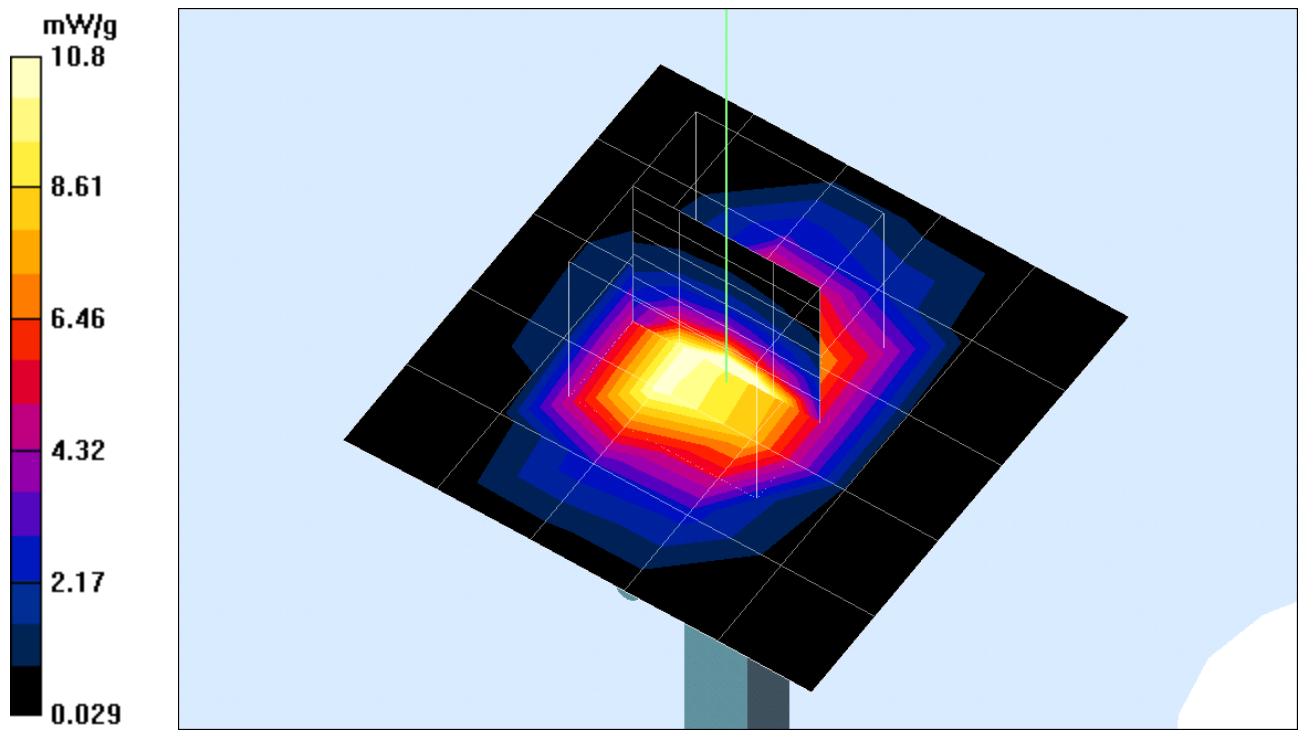

Test Laboratory: Compliance Certification Services Inc.

Test Configuration-1

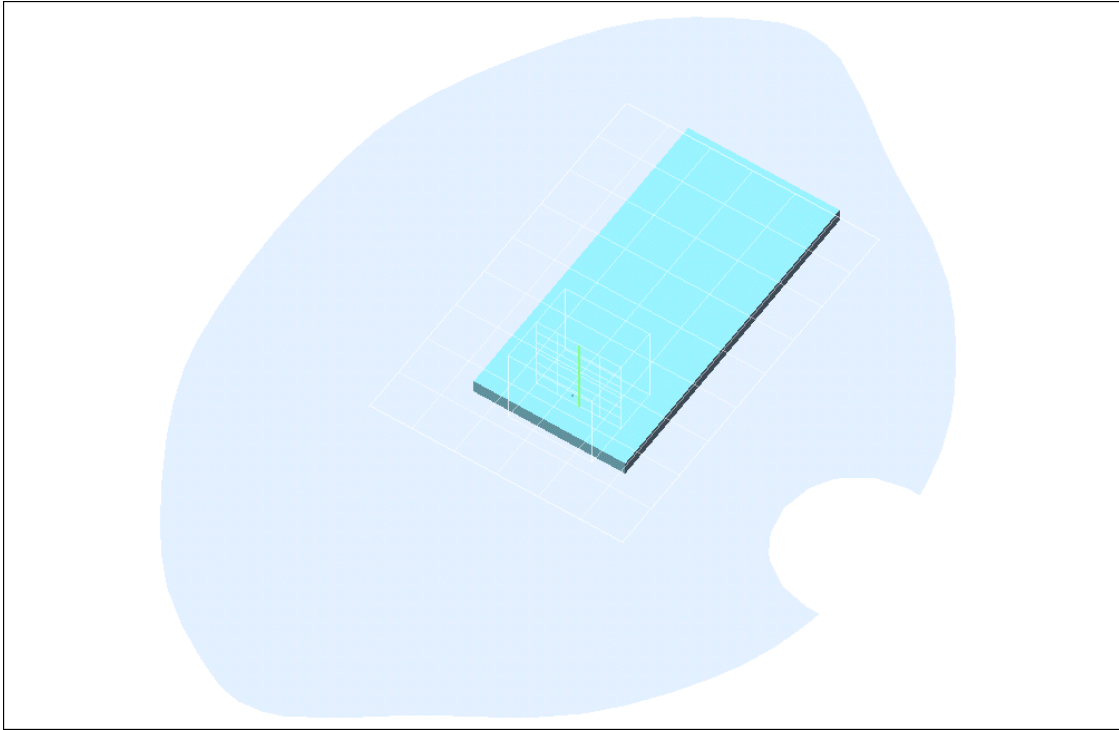

0 dB = 0.843mW/g

Test Laboratory: Compliance Certification Services Inc.

Touch mode(with Compaq)

DUT: 802.11b Wireless LAN Cardbus Card ; Type: 11-36; Serial: N/A

Communication System:IEEE 802.11b ; Frequency: 2412 MHz;Duty Cycle: 1:1

Medium: BSL2450 ($\sigma = 1.98$ mho/m, $\epsilon_r = 51.3$, $\rho = 1000$ kg/m³)

Air Temperature 25.3 deg C ;Liquid Temperature 24.3 deg C

Phantom section: Flat Section

DASY4 Configuration:

- Probe: ET3DV6 - SN1762; ConvF(4.6, 4.6, 4.6); Calibrated: 3/31/2003
- Sensor-Surface: 4mm (Mechanical And Optical Surface Detection)
Sensor-Surface: 0mm (Fix Surface)
- Electronics: DAE3 Sn558; Calibrated: 3/7/2003
- Phantom: SAM 34; Type: SAM V4.0; Serial: TP-1150
- Measurement SW: DASY4, V4.1 Build 47; Postprocessing SW: SEMCAD, V1.8 Build 62

Low Rate=11M bit/Area Scan (7x10x1): Measurement grid: dx=15mm, dy=15mm

Reference Value = 24.1 V/m

Power Drift = -0.1 dB

Maximum value of SAR = 0.753 mW/g

Low Rate=11M bit/Z Scan (1x1x21): Measurement grid: dx=20mm, dy=20mm, dz=5mm

Reference Value = 24.1 V/m

Power Drift = -0.1 dB

Maximum value of SAR = 0.909 mW/g

Low Rate=11M bit/Zoom Scan (5x5x7)/Cube 0: Measurement grid: dx=7.5mm, dy=7.5mm, dz=5mm

Peak SAR (extrapolated) = 2.08 W/kg

SAR(1 g) = 0.977 mW/g; SAR(10 g) = 0.484 mW/g

Reference Value = 24.1 V/m

Power Drift = -0.1 dB

Maximum value of SAR = 1.07 mW/g

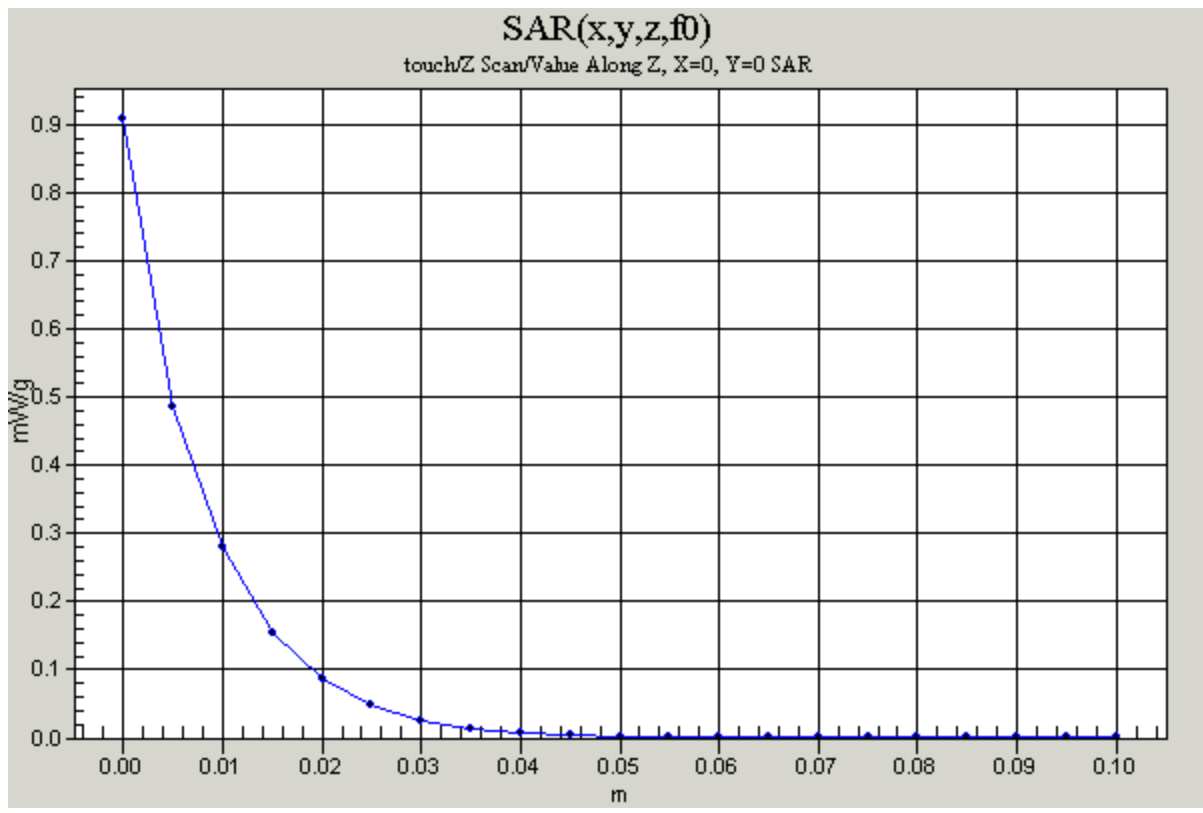
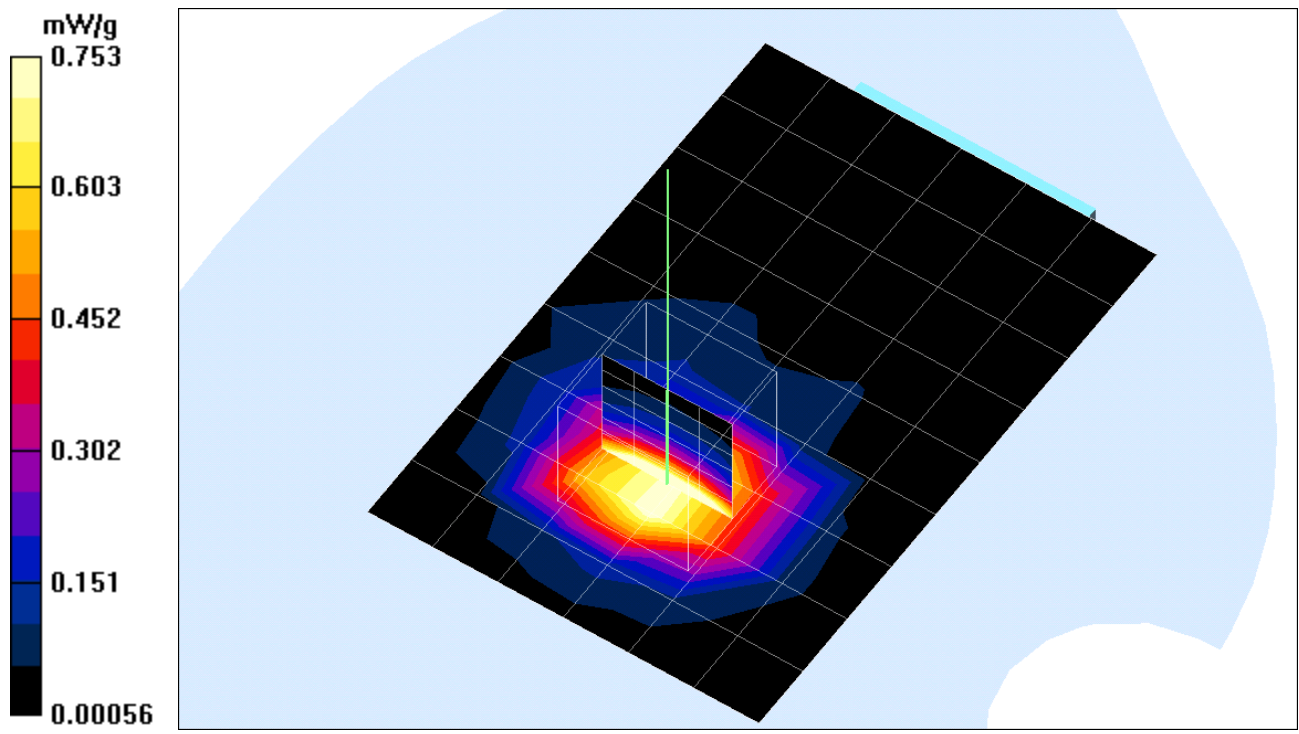

Test Laboratory: Compliance Certification Services Inc.

Touch mode(with Compaq)

DUT: 802.11b Wireless LAN Cardbus Card ; Type: 11-36; Serial: N/A

Communication System: IEEE 802.11b ; Frequency: 2437 MHz;Duty Cycle: 1:1

Medium: BSL2450 ($\sigma = 1.98$ mho/m, $\epsilon_r = 51.3$, $\rho = 1000$ kg/m³)

Air Temperature 25.3 deg C ;Liquid Temperature 24.3 deg C

Phantom section: Flat Section

DASY4 Configuration:

- Probe: ET3DV6 - SN1762; ConvF(4.6, 4.6, 4.6); Calibrated: 3/31/2003
- Sensor-Surface: 4mm (Mechanical And Optical Surface Detection)
Sensor-Surface: 0mm (Fix Surface)
- Electronics: DAE3 Sn558; Calibrated: 3/7/2003
- Phantom: SAM 34; Type: SAM V4.0; Serial: TP-1150
- Measurement SW: DASY4, V4.1 Build 47; Postprocessing SW: SEMCAD, V1.8 Build 62

mid Rate=11M bit/Area Scan (7x6x1): Measurement grid: dx=15mm, dy=15mm

Reference Value = 24.3 V/m

Power Drift = -0.1 dB

Maximum value of SAR = 0.785 mW/g

mid Rate=11M bit/Z Scan (1x1x21): Measurement grid: dx=20mm, dy=20mm, dz=5mm

Reference Value = 24.3 V/m

Power Drift = -0.1 dB

Maximum value of SAR = 0.877 mW/g

mid Rate=11M bit/Zoom Scan (5x5x7)/Cube 0: Measurement grid: dx=7.5mm, dy=7.5mm, dz=5mm

Peak SAR (extrapolated) = 2.05 W/kg

SAR(1 g) = 0.953 mW/g; SAR(10 g) = 0.471 mW/g

Reference Value = 24.3 V/m

Power Drift = -0.1 dB

Maximum value of SAR = 1.03 mW/g

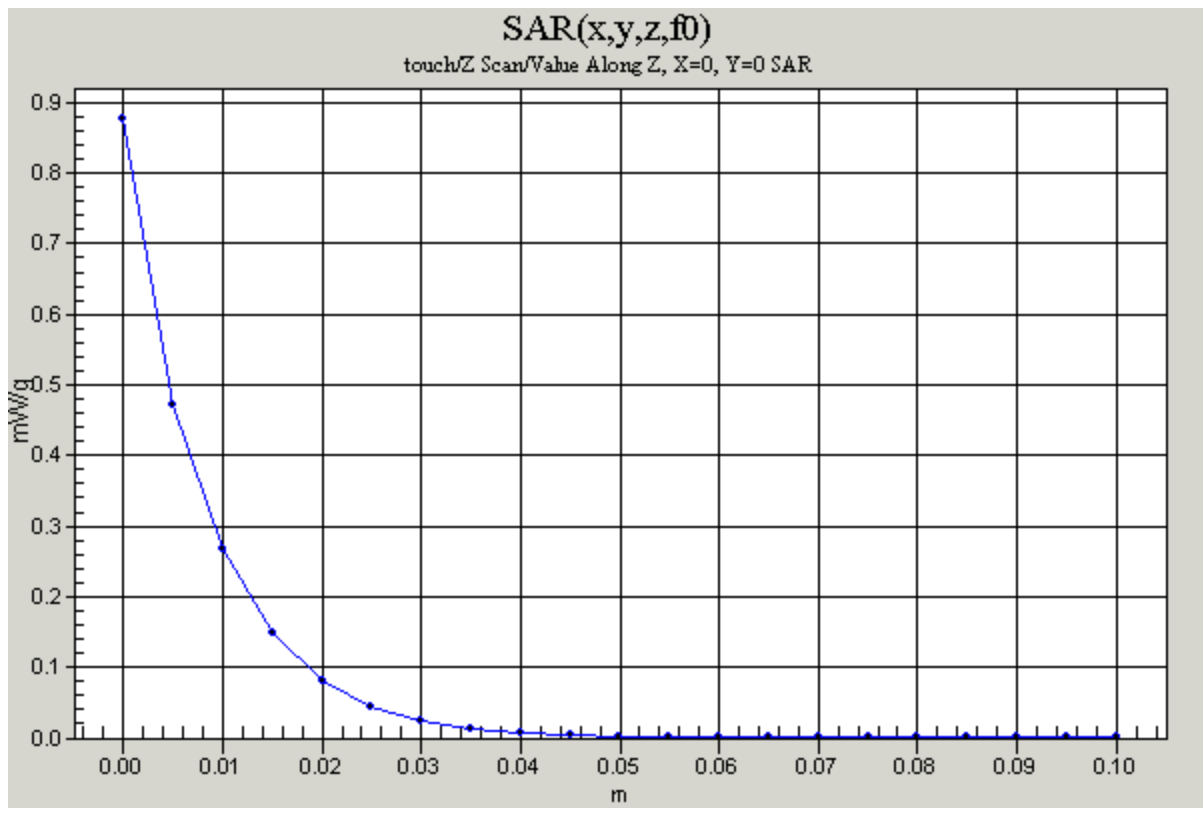
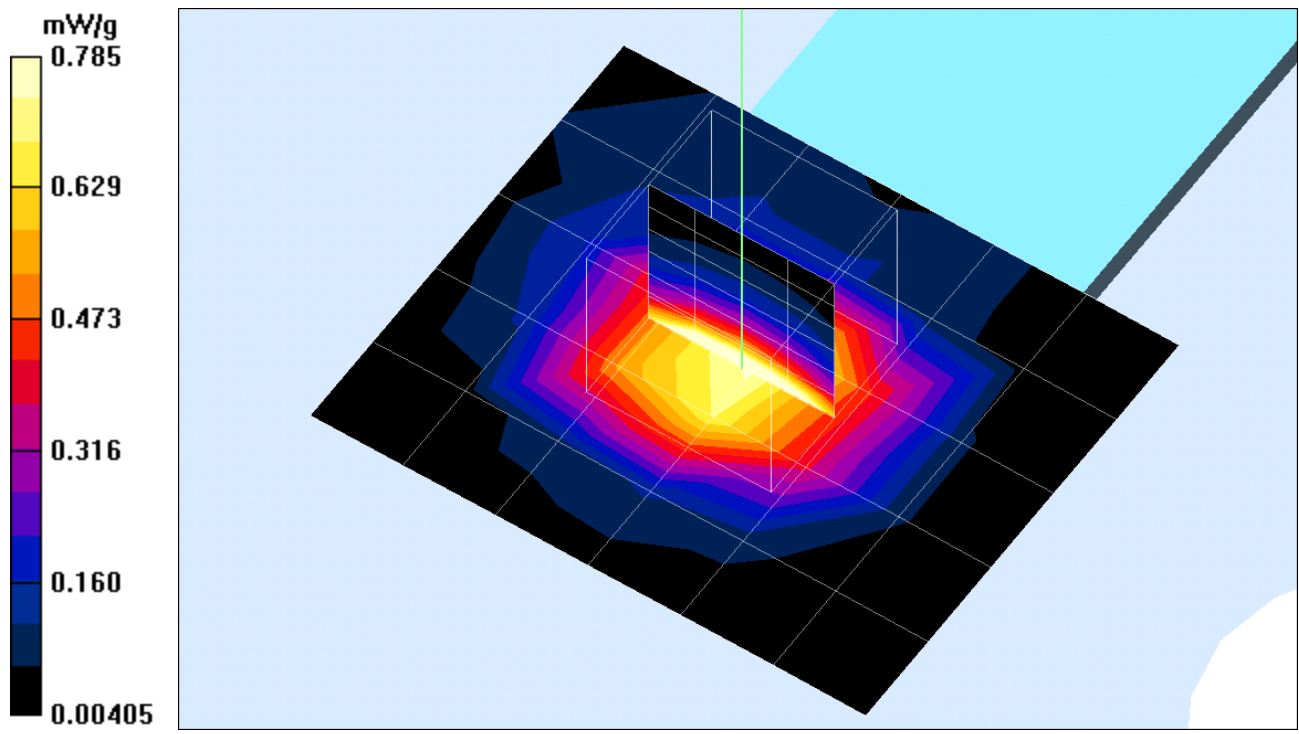

Test Laboratory: Compliance Certification Services Inc.

Touch mode(with Compaq)

DUT: 802.11b Wireless LAN Cardbus Card ; Type: 11-36; Serial: N/A

Communication System: IEEE 802.11b ; Frequency: 2462 MHz;Duty Cycle: 1:1

Medium: BSL2450 ($\sigma = 1.98$ mho/m, $\epsilon_r = 51.3$, $\rho = 1000$ kg/m³)

Air Temperature 25.3 deg C ;Liquid Temperature 24.3 deg C

Phantom section: Flat Section

DASY4 Configuration:

- Probe: ET3DV6 - SN1762; ConvF(4.6, 4.6, 4.6); Calibrated: 3/31/2003
- Sensor-Surface: 4mm (Mechanical And Optical Surface Detection)
Sensor-Surface: 0mm (Fix Surface)
- Electronics: DAE3 Sn558; Calibrated: 3/7/2003
- Phantom: SAM 34; Type: SAM V4.0; Serial: TP-1150
- Measurement SW: DASY4, V4.1 Build 47; Postprocessing SW: SEMCAD, V1.8 Build 62

High Rate=11M bit/Area Scan (7x6x1): Measurement grid: dx=15mm, dy=15mm

Reference Value = 20.9 V/m

Power Drift = -0.1 dB

Maximum value of SAR = 0.921 mW/g

High Rate=11M bit/Z Scan (1x1x21): Measurement grid: dx=20mm, dy=20mm, dz=5mm

Reference Value = 20.9 V/m

Power Drift = -0.1 dB

Maximum value of SAR = 0.810 mW/g

High Rate=11M bit/Zoom Scan (5x5x7)/Cube 0: Measurement grid: dx=7.5mm, dy=7.5mm, dz=5mm

Peak SAR (extrapolated) = 1.98 W/kg

SAR(1 g) = 0.911 mW/g; SAR(10 g) = 0.447 mW/g

Reference Value = 20.9 V/m

Power Drift = -0.1 dB

Maximum value of SAR = 0.978 mW/g

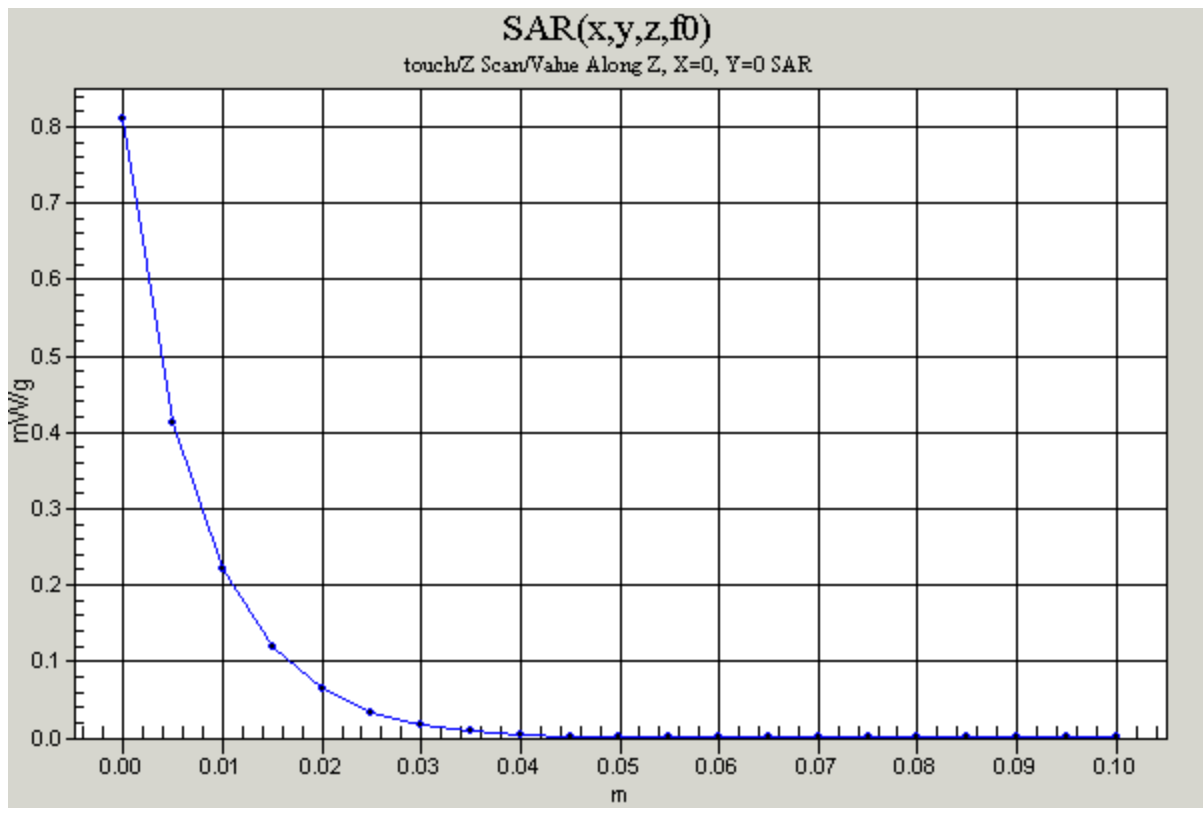
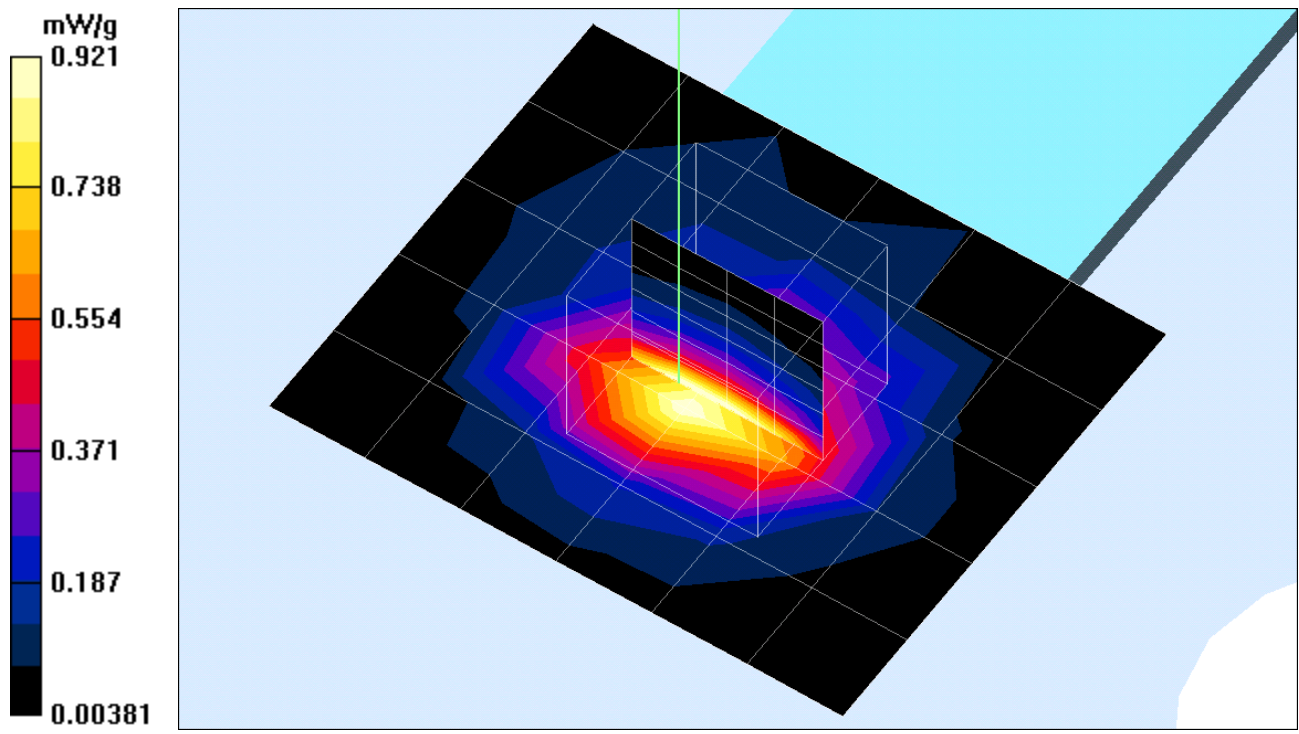

Test Laboratory: Compliance Certification Services Inc.

Touch mode(with IBM-R31)

DUT: 802.11b Wireless LAN Cardbus Card ; Type: 11-36; Serial: N/A

Communication System: IEE 802.11b ; Frequency: 2412 MHz;Duty Cycle: 1:1

Medium: BSL2450 ($\sigma = 1.98$ mho/m, $\epsilon_r = 51.3$, $\rho = 1000$ kg/m³)

Air Temperature 25.3 deg C ;Liquid Temperature 24.3 deg C

Phantom section: Flat Section

DASY4 Configuration:

- Probe: ET3DV6 - SN1762; ConvF(4.6, 4.6, 4.6); Calibrated: 3/31/2003
- Sensor-Surface: 4mm (Mechanical And Optical Surface Detection)
Sensor-Surface: 0mm (Fix Surface)
- Electronics: DAE3 Sn558; Calibrated: 3/7/2003
- Phantom: SAM 34; Type: SAM V4.0; Serial: TP-1150
- Measurement SW: DASY4, V4.1 Build 47; Postprocessing SW: SEMCAD, V1.8 Build 62

Low Rate=11M bit/Area Scan (7x10x1): Measurement grid: dx=15mm, dy=15mm

Reference Value = 21.1 V/m

Power Drift = -0.1 dB

Maximum value of SAR = 0.742 mW/g

Low Rate=11M bit/Z Scan (1x1x21): Measurement grid: dx=20mm, dy=20mm, dz=5mm

Reference Value = 21.1 V/m

Power Drift = -0.1 dB

Maximum value of SAR = 0.697 mW/g

Low Rate=11M bit/Zoom Scan (5x5x7)/Cube 0: Measurement grid: dx=7.5mm, dy=7.5mm, dz=5mm

Peak SAR (extrapolated) = 1.66 W/kg

SAR(1 g) = 0.781 mW/g; SAR(10 g) = 0.389 mW/g

Reference Value = 21.1 V/m

Power Drift = -0.1 dB

Maximum value of SAR = 0.843 mW/g

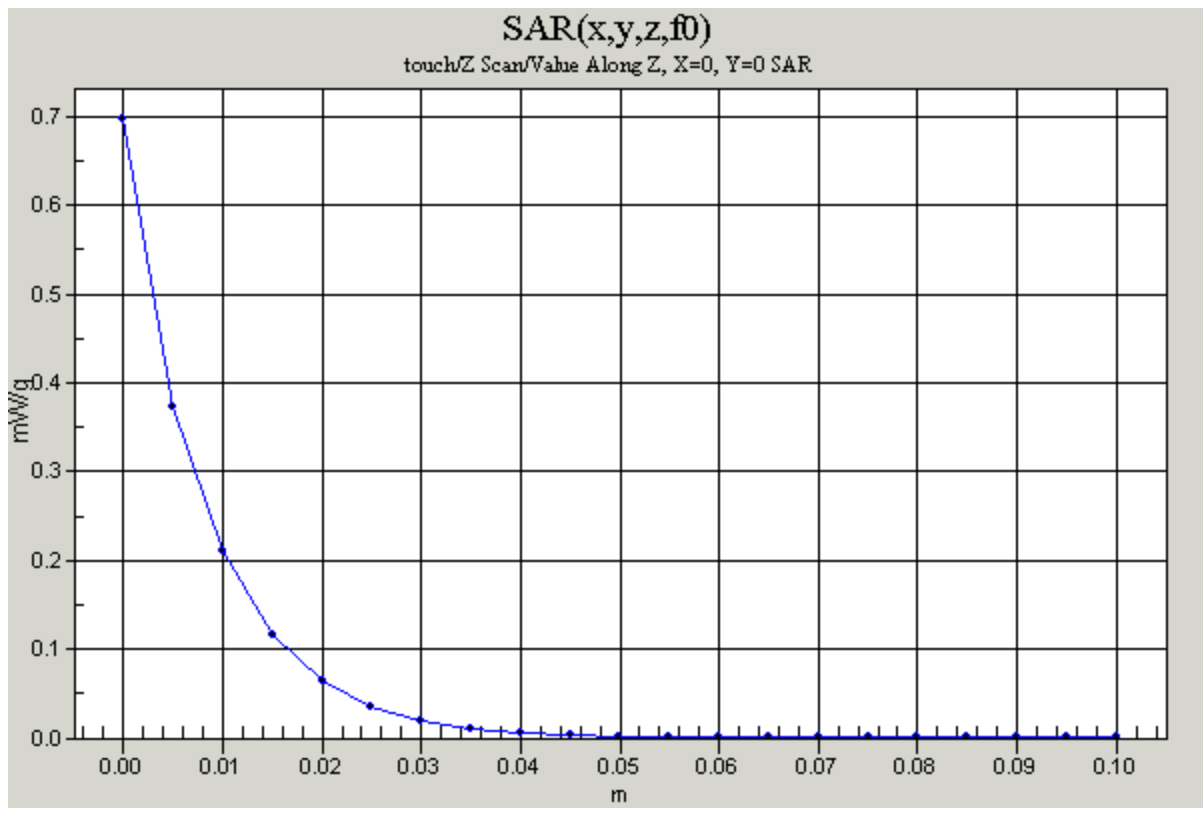
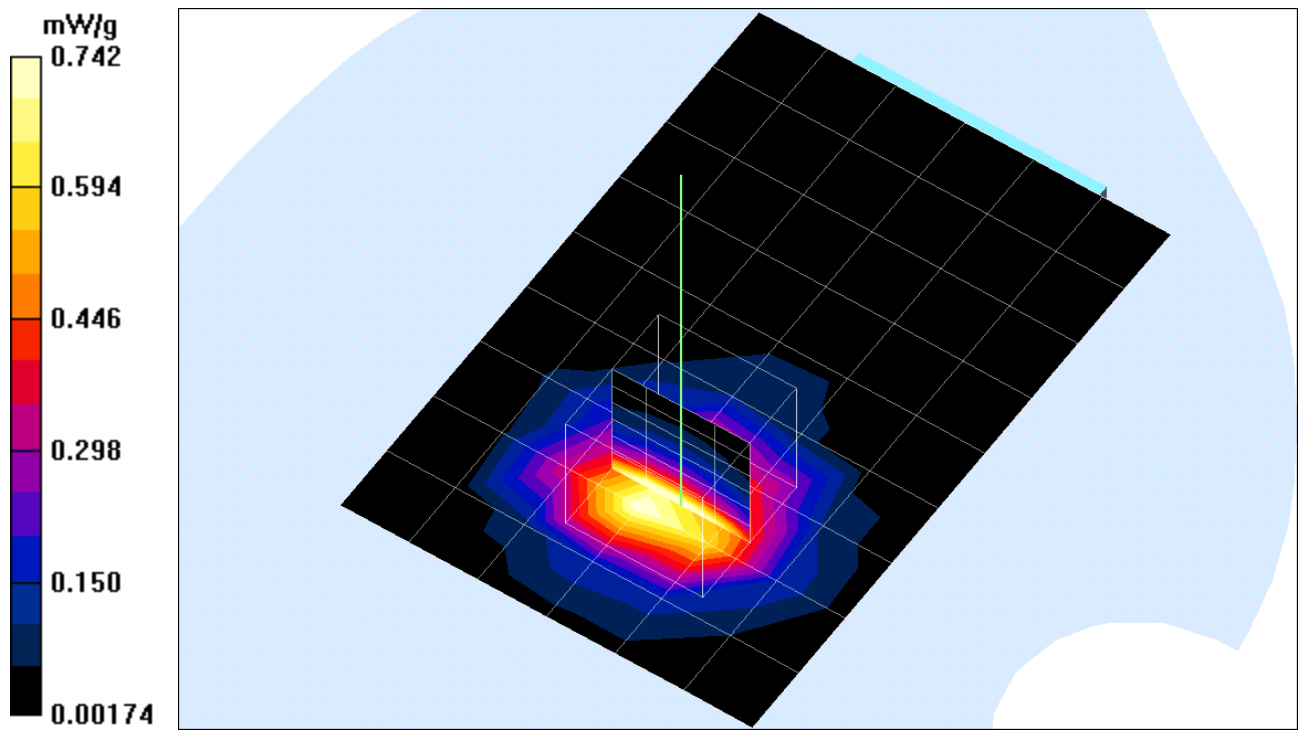

Test Laboratory: Compliance Certification Services Inc.

Touch mode(with IBM-R31)

DUT: 802.11b Wireless LAN Cardbus Card ; Type: 11-36; Serial: N/A

Communication System: IEE 802.11b ; Frequency: 2437 MHz;Duty Cycle: 1:1

Medium: BSL2450 ($\sigma = 1.98$ mho/m, $\epsilon_r = 51.3$, $\rho = 1000$ kg/m³)

Air Temperature 25.3 deg C ;Liquid Temperature 24.3 deg C

Phantom section: Flat Section

DASY4 Configuration:

- Probe: ET3DV6 - SN1762; ConvF(4.6, 4.6, 4.6); Calibrated: 3/31/2003
- Sensor-Surface: 4mm (Mechanical And Optical Surface Detection)
Sensor-Surface: 0mm (Fix Surface)
- Electronics: DAE3 Sn558; Calibrated: 3/7/2003
- Phantom: SAM 34; Type: SAM V4.0; Serial: TP-1150
- Measurement SW: DASY4, V4.1 Build 47; Postprocessing SW: SEMCAD, V1.8 Build 62

mid Rate=11M bit/Area Scan (7x6x1): Measurement grid: dx=15mm, dy=15mm

Reference Value = 18.6 V/m

Power Drift = -0.1 dB

Maximum value of SAR = 0.710 mW/g

mid Rate=11M bit/Z Scan (1x1x21): Measurement grid: dx=20mm, dy=20mm, dz=5mm

Reference Value = 18.6 V/m

Power Drift = -0.1 dB

Maximum value of SAR = 0.650 mW/g

mid Rate=11M bit/Zoom Scan (5x5x7)/Cube 0: Measurement grid: dx=7.5mm, dy=7.5mm, dz=5mm

Peak SAR (extrapolated) = 1.5 W/kg

SAR(1 g) = 0.704 mW/g; SAR(10 g) = 0.355 mW/g

Reference Value = 18.6 V/m

Power Drift = -0.1 dB

Maximum value of SAR = 0.757 mW/g

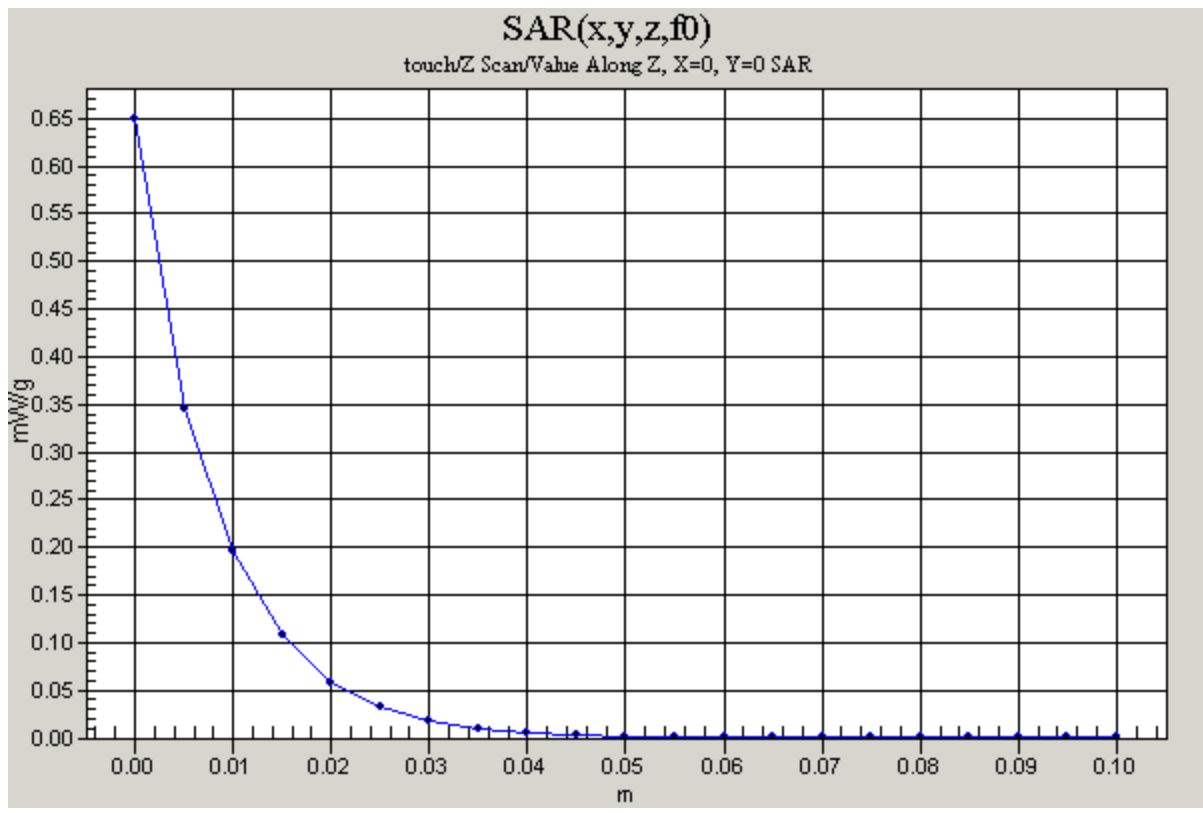
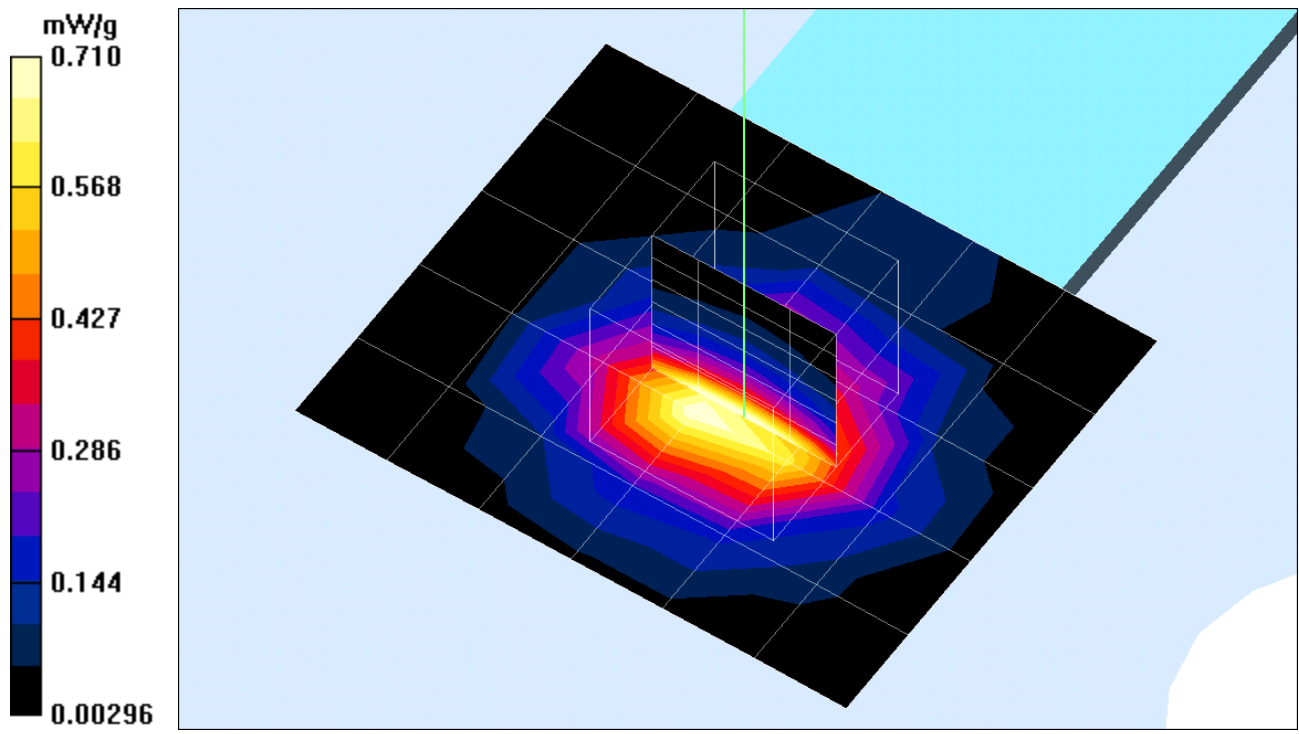

Test Laboratory: Compliance Certification Services Inc.

Touch mode(with IBM-R31)

DUT: 802.11b Wireless LAN Cardbus Card ; Type: 11-36; Serial: N/A

Communication System: IEE 802.11b ; Frequency: 2462 MHz;Duty Cycle: 1:1

Medium: BSL2450 ($\sigma = 1.98$ mho/m, $\epsilon_r = 51.3$, $\rho = 1000$ kg/m³)

Air Temperature 25.3 deg C ;Liquid Temperature 24.3 deg C

Phantom section: Flat Section

DASY4 Configuration:

- Probe: ET3DV6 - SN1762; ConvF(4.6, 4.6, 4.6); Calibrated: 3/31/2003
- Sensor-Surface: 4mm (Mechanical And Optical Surface Detection)
Sensor-Surface: 0mm (Fix Surface)
- Electronics: DAE3 Sn558; Calibrated: 3/7/2003
- Phantom: SAM 34; Type: SAM V4.0; Serial: TP-1150
- Measurement SW: DASY4, V4.1 Build 47; Postprocessing SW: SEMCAD, V1.8 Build 62

High Rate=11M bit/Area Scan (7x6x1): Measurement grid: dx=15mm, dy=15mm

Reference Value = 18.4 V/m

Power Drift = -0.1 dB

Maximum value of SAR = 0.596 mW/g

High Rate=11M bit/Z Scan (1x1x21): Measurement grid: dx=20mm, dy=20mm, dz=5mm

Reference Value = 18.4 V/m

Power Drift = -0.1 dB

Maximum value of SAR = 0.503 mW/g

High Rate=11M bit/Zoom Scan (5x5x7)/Cube 0: Measurement grid: dx=7.5mm, dy=7.5mm, dz=5mm

Peak SAR (extrapolated) = 1.31 W/kg

SAR(1 g) = 0.598 mW/g; SAR(10 g) = 0.297 mW/g

Reference Value = 18.4 V/m

Power Drift = -01 dB

Maximum value of SAR = 0.639 mW/g

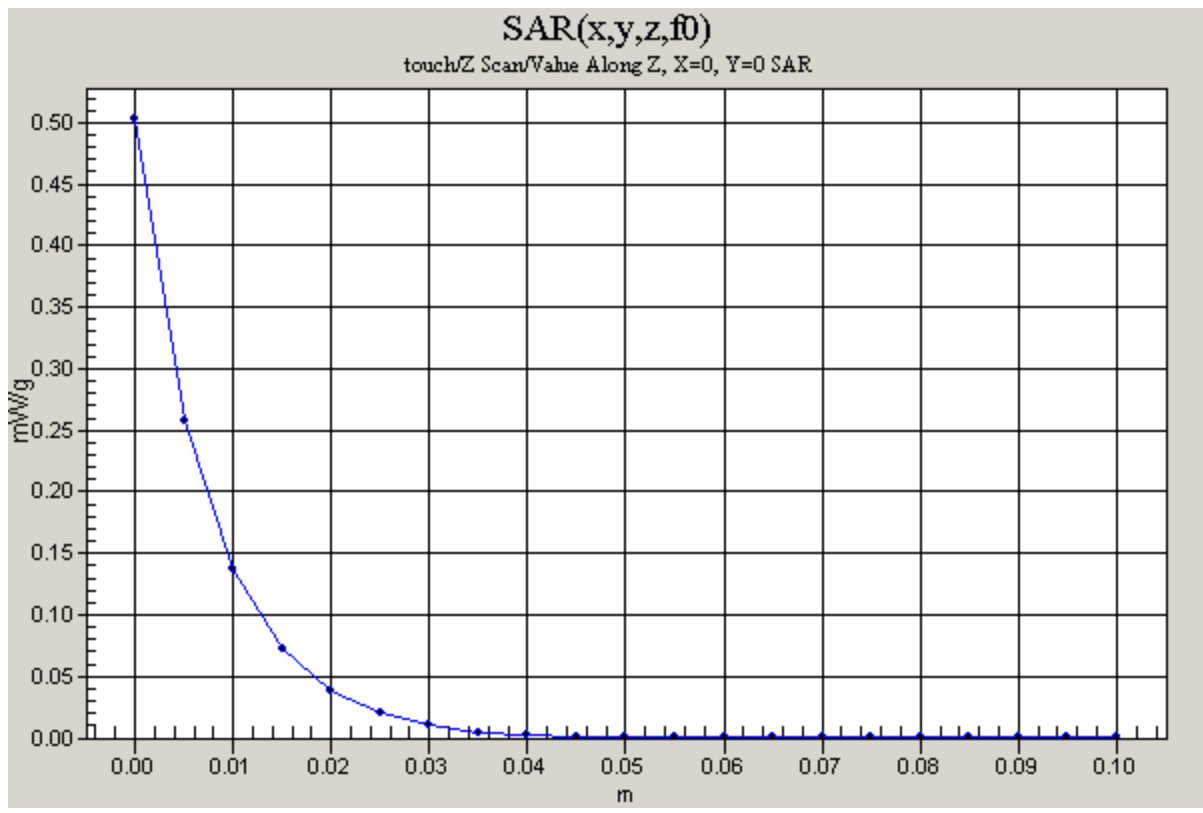
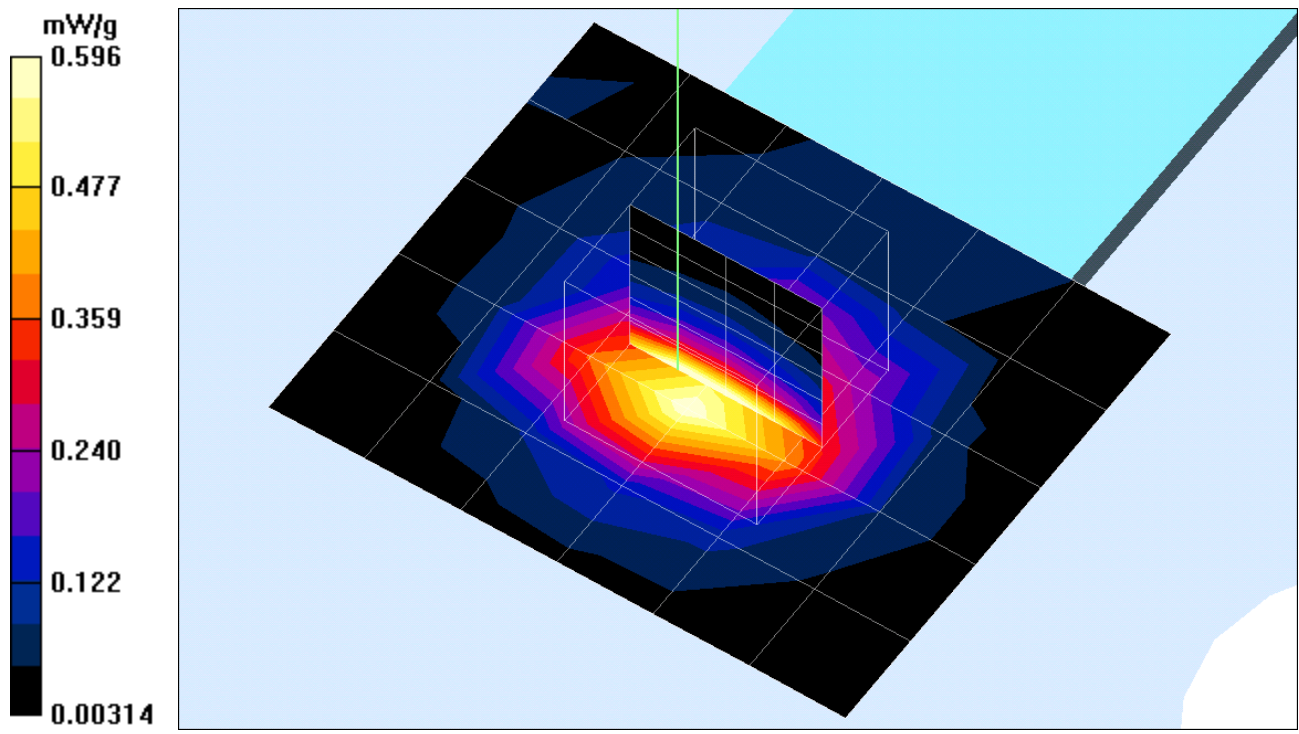

Test Laboratory: Compliance Certification Services Inc.

Touch mode(with IBM)

DUT: 802.11b Wireless LAN Cardbus PC Card ; Type: N/A; Serial: N/A

Communication System:IEEE 802.11b; Frequency: 2412 MHz;Duty Cycle: 1:1

Medium: BSL2450 ($\sigma = 1.98$ mho/m, $\epsilon_r = 51.3$, $\rho = 1000$ kg/m³)

Air Temperature 25.3 deg C ;Liquid Temperature 24.3 deg C

Phantom section: Flat Section

DASY4 Configuration:

- Probe: ET3DV6 - SN1762; ConvF(4.6, 4.6, 4.6); Calibrated: 3/31/2003
- Sensor-Surface: 4mm (Mechanical Surface Detection)
Sensor-Surface: 0mm (Fix Surface)
Sensor-Surface: 4mm (Mechanical And Optical Surface Detection)
- Electronics: DAE3 Sn558; Calibrated: 3/7/2003
- Phantom: SAM 34; Type: SAM V4.0; Serial: TP-1150
- Measurement SW: DASY4, V4.1 Build 47; Postprocessing SW: SEMCAD, V1.8 Build 62

Low Rate=11M bit/Area Scan (7x10x1): Measurement grid: dx=15mm, dy=15mm

Reference Value = 20.9 V/m

Power Drift = -0.1 dB

Maximum value of SAR = 0.895 mW/g

Low Rate=11M bit/Z Scan (1x1x21): Measurement grid: dx=20mm, dy=20mm, dz=5mm

Reference Value = 20.9 V/m

Power Drift = -0.1 dB

Maximum value of SAR = 0.811 mW/g

Low Rate=11M bit/Zoom Scan (5x5x7)/Cube 0: Measurement grid: dx=7.5mm, dy=7.5mm, dz=5mm

Peak SAR (extrapolated) = 1.99 W/kg

SAR(1 g) = 0.914 mW/g; SAR(10 g) = 0.447 mW/g

Reference Value = 20.9 V/m

Power Drift = -0.1 dB

Maximum value of SAR = 0.986 mW/g

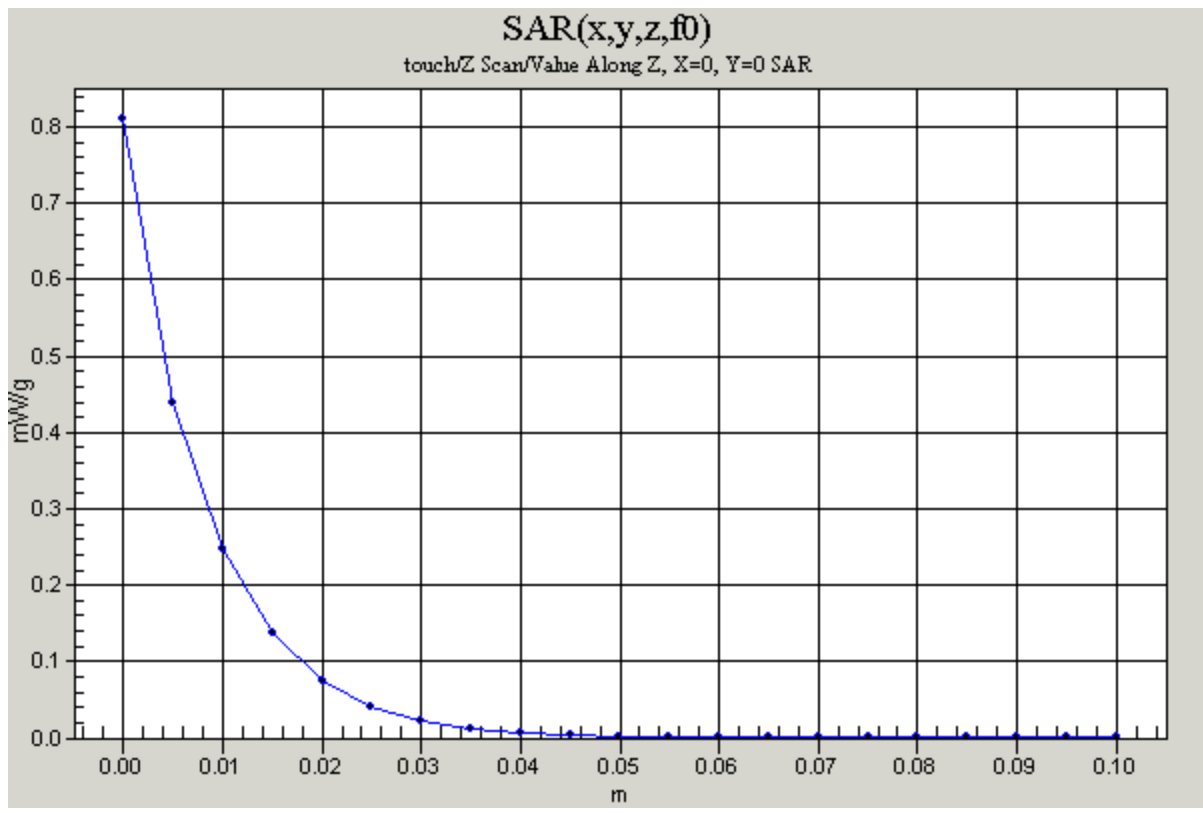
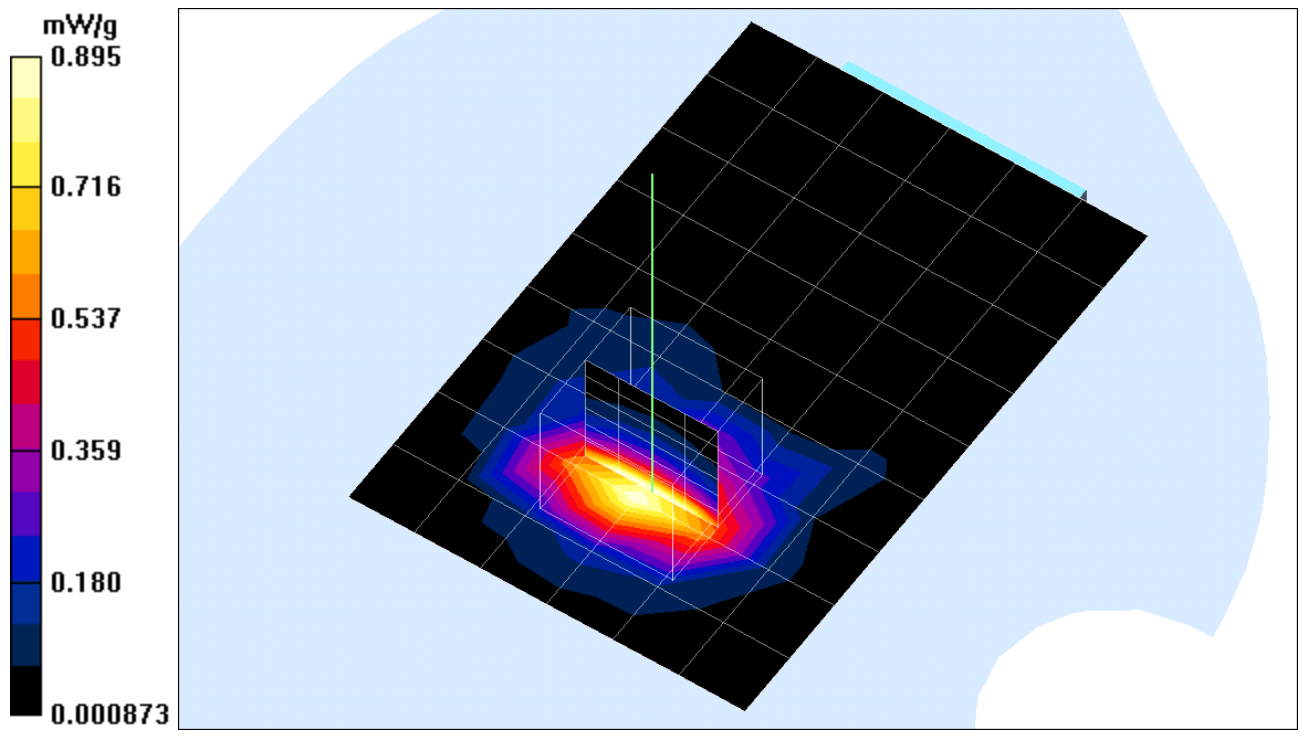

Test Laboratory: Compliance Certification Services Inc.

Touch mode(with IBM)

DUT: 802.11b Wireless LAN Cardbus PC Card ; Type: N/A; Serial: N/A

Communication System: IEEE 802.11b ; Frequency: 2437 MHz;Duty Cycle: 1:1

Medium: BSL2450 ($\sigma = 1.98$ mho/m, $\epsilon_r = 51.3$, $\rho = 1000$ kg/m³)

Air Temperature 25.3 deg C ;Liquid Temperature 24.3 deg C

Phantom section: Flat Section

DASY4 Configuration:

- Probe: ET3DV6 - SN1762; ConvF(4.6, 4.6, 4.6); Calibrated: 3/31/2003
- Sensor-Surface: 4mm (Mechanical And Optical Surface Detection)
Sensor-Surface: 0mm (Fix Surface)
- Electronics: DAE3 Sn558; Calibrated: 3/7/2003
- Phantom: SAM 34; Type: SAM V4.0; Serial: TP-1150
- Measurement SW: DASY4, V4.1 Build 47; Postprocessing SW: SEMCAD, V1.8 Build 62

mid Rate=11M bit/Area Scan (7x6x1): Measurement grid: dx=15mm, dy=15mm

Reference Value = 17.7 V/m

Power Drift = -0.1 dB

Maximum value of SAR = 1.05 mW/g

mid Rate=11M bit/Z Scan (1x1x21): Measurement grid: dx=20mm, dy=20mm, dz=5mm

Reference Value = 17.7 V/m

Power Drift = -0.1 dB

Maximum value of SAR = 0.836 mW/g

mid Rate=11M bit/Zoom Scan (5x5x7)/Cube 0: Measurement grid: dx=7.5mm, dy=7.5mm, dz=5mm

Peak SAR (extrapolated) = 2.06 W/kg

SAR(1 g) = 0.965 mW/g; SAR(10 g) = 0.476 mW/g

Reference Value = 17.7 V/m

Power Drift = -0.1 dB

Maximum value of SAR = 1.04 mW/g

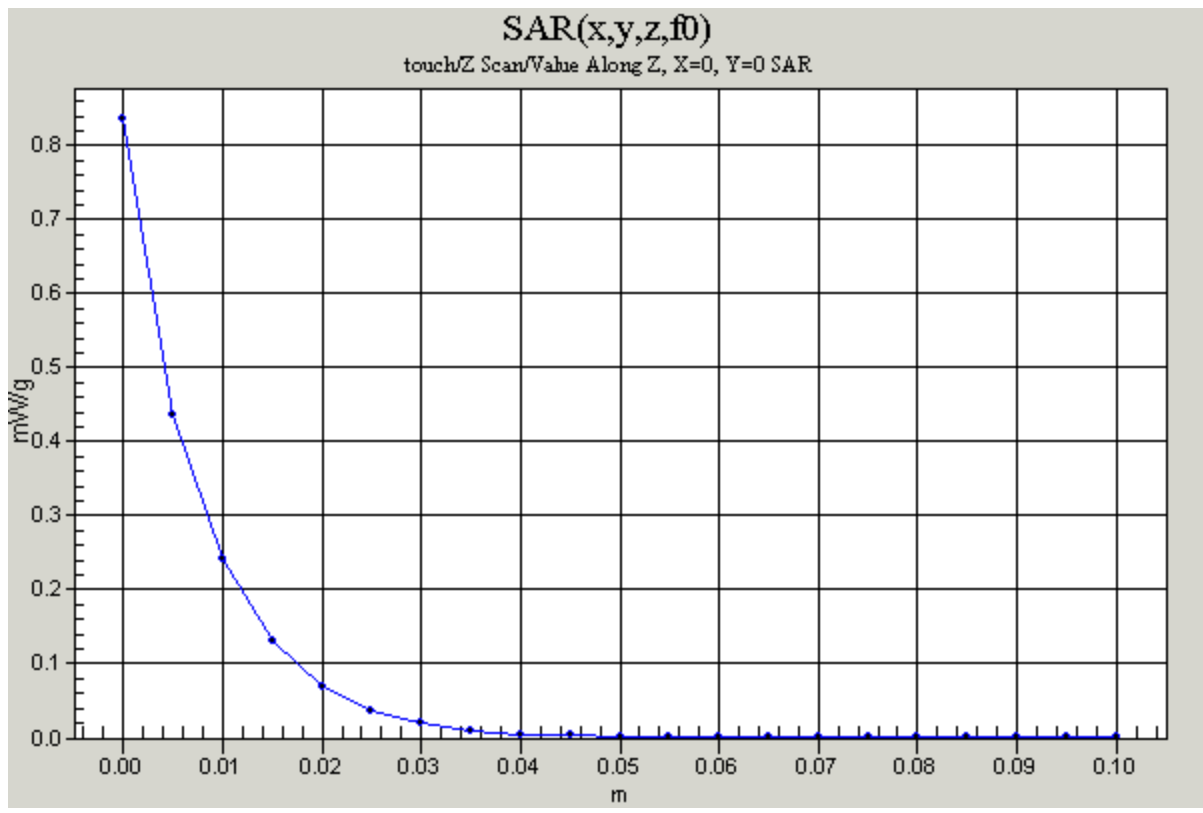
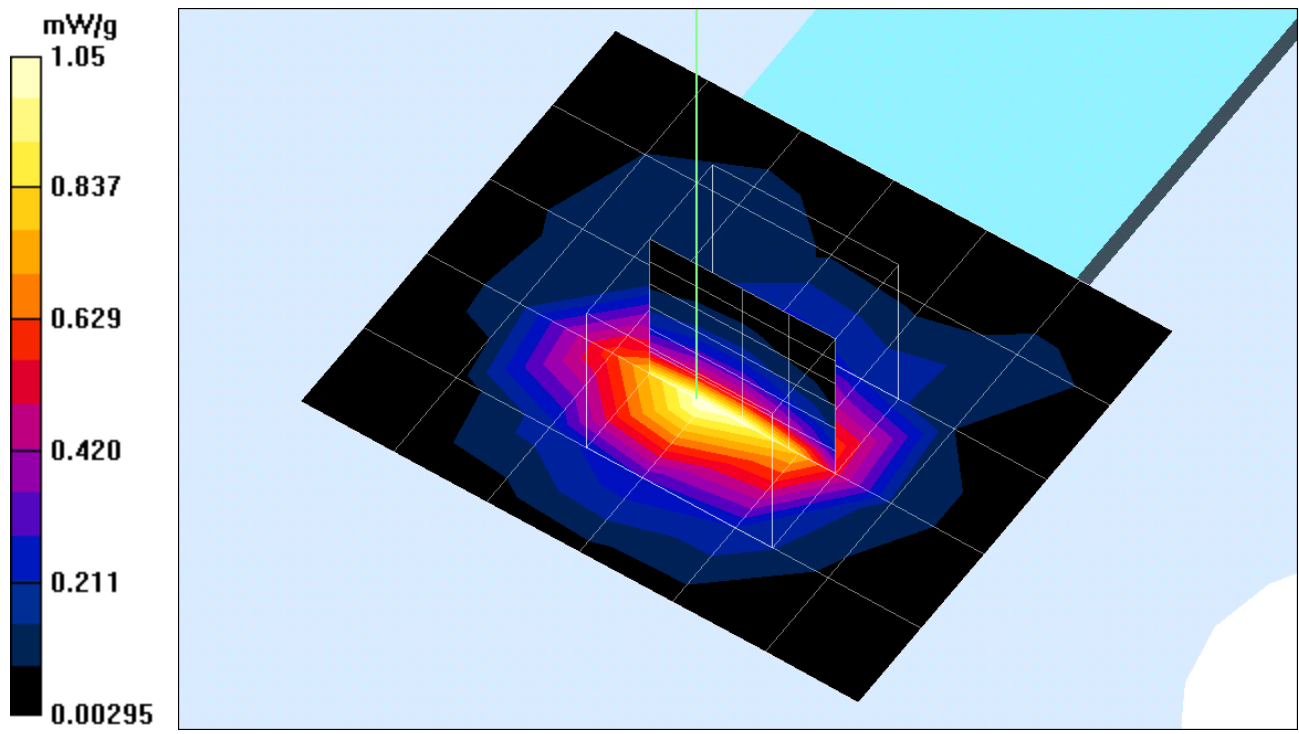

Test Laboratory: Compliance Certification Services Inc.

Touch mode(with IBM)

DUT: 802.11b Wireless LAN Cardbus PC Card ; Type: N/A; Serial: N/A

Communication System: IEEE 802.11b ; Frequency: 2462 MHz;Duty Cycle: 1:1

Medium: BSL2450 ($\sigma = 1.98$ mho/m, $\epsilon_r = 51.3$, $\rho = 1000$ kg/m³)

Air Temperature 25.3 deg C ;Liquid Temperature 24.3 deg C

Phantom section: Flat Section

DASY4 Configuration:

- Probe: ET3DV6 - SN1762; ConvF(4.6, 4.6, 4.6); Calibrated: 3/31/2003
- Sensor-Surface: 4mm (Mechanical And Optical Surface Detection)
Sensor-Surface: 0mm (Fix Surface)
- Electronics: DAE3 Sn558; Calibrated: 3/7/2003
- Phantom: SAM 34; Type: SAM V4.0; Serial: TP-1150
- Measurement SW: DASY4, V4.1 Build 47; Postprocessing SW: SEMCAD, V1.8 Build 62

High Rate=11M bit/Area Scan (7x6x1): Measurement grid: dx=15mm, dy=15mm

Reference Value = 23.8 V/m

Power Drift = 0.1 dB

Maximum value of SAR = 0.847 mW/g

High Rate=11M bit/Z Scan (1x1x21): Measurement grid: dx=20mm, dy=20mm, dz=5mm

Reference Value = 23.8 V/m

Power Drift = 0.1 dB

Maximum value of SAR = 0.806 mW/g

High Rate=11M bit/Zoom Scan (5x5x7)/Cube 0: Measurement grid: dx=7.5mm, dy=7.5mm, dz=5mm

Peak SAR (extrapolated) = 2.09 W/kg

SAR(1 g) = 0.932 mW/g; SAR(10 g) = 0.455 mW/g

Reference Value = 23.8 V/m

Power Drift = 0.1 dB

Maximum value of SAR = 1.02 mW/g

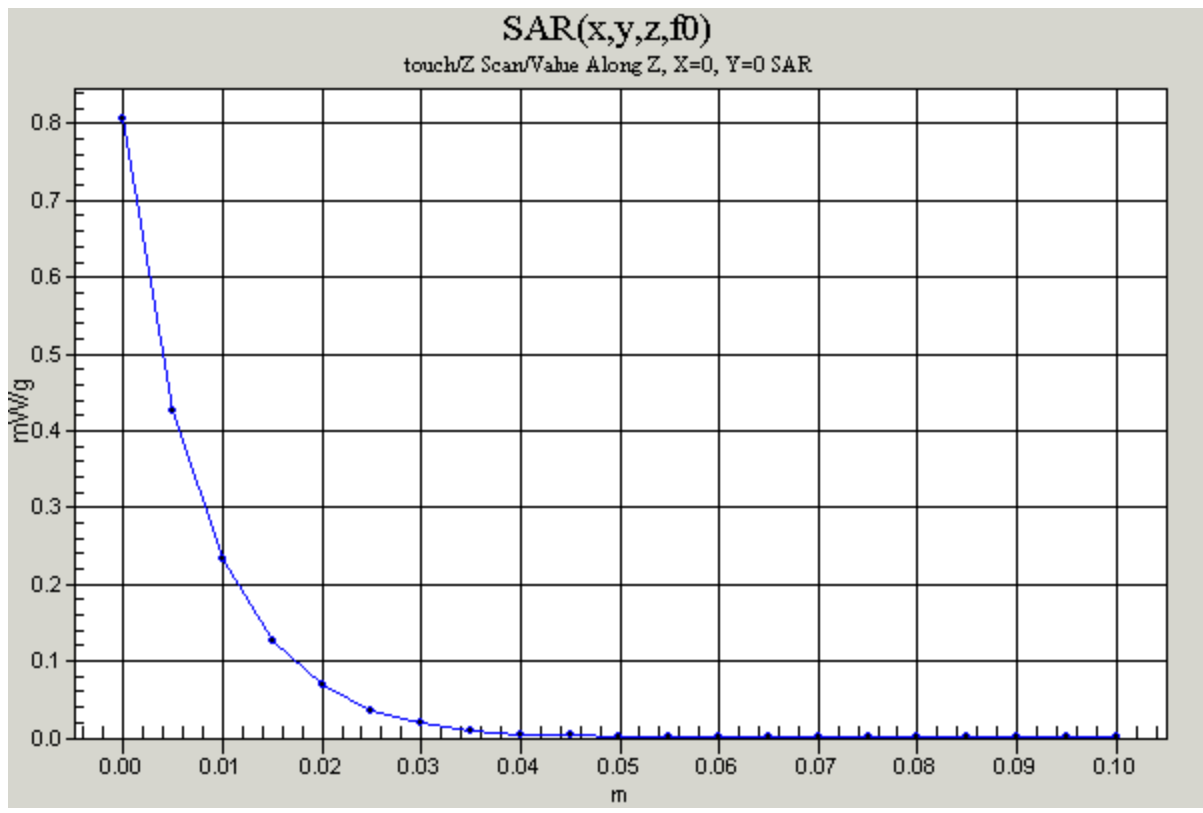
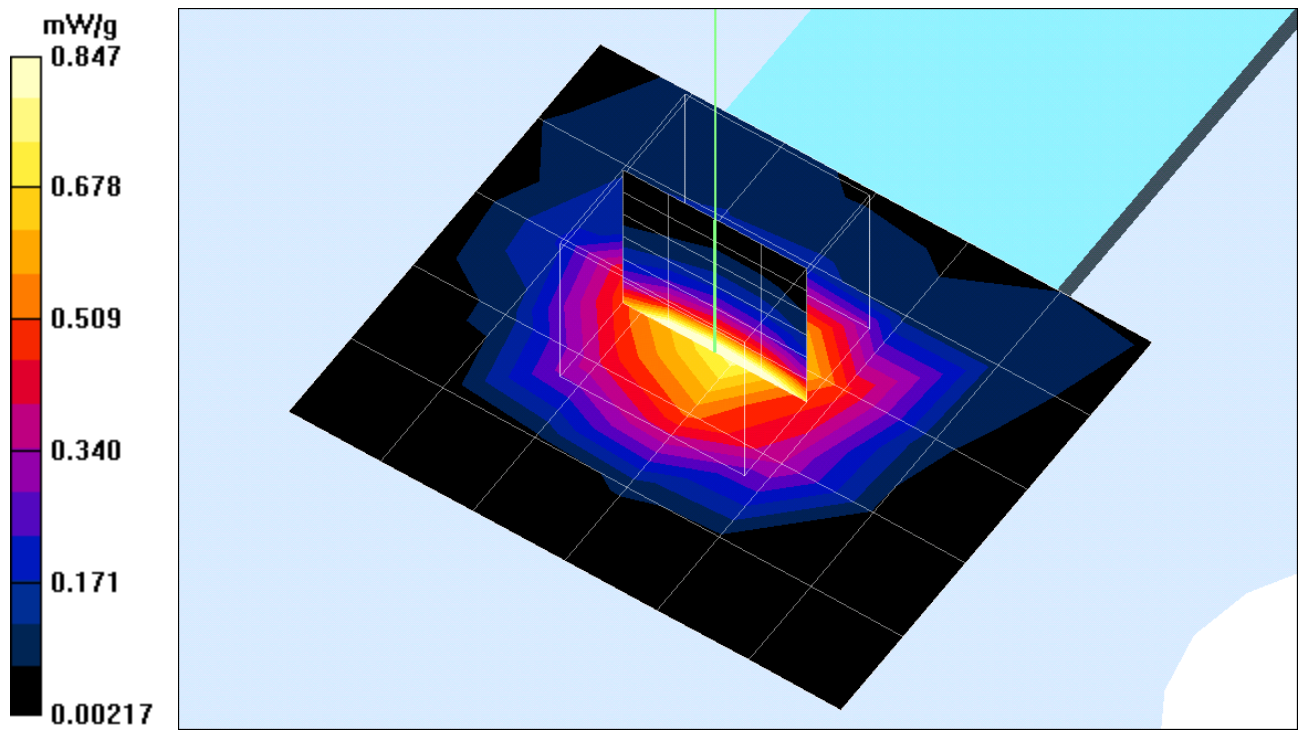

Test Laboratory: Compliance Certification Services Inc.

Test Configuration-2

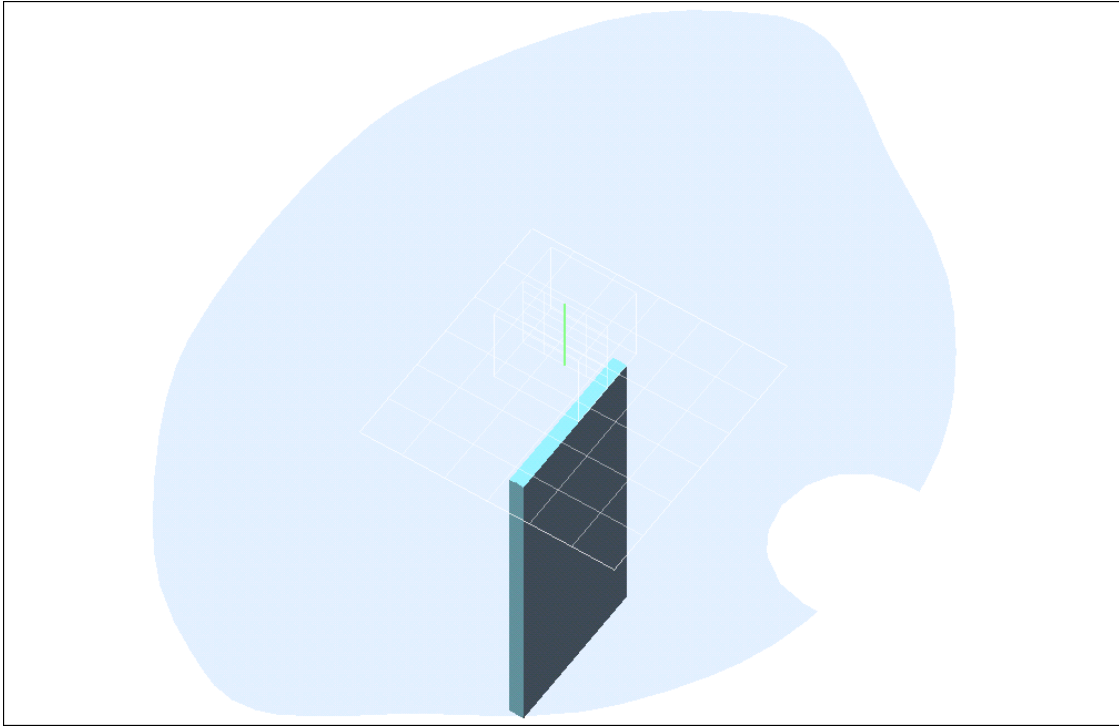

Test Laboratory: Compliance Certification Services Inc.

15mm mode(with Compaq)

DUT: 802.11b Wireless LAN Cardbus Card ; Type: 11-36; Serial: N/A

Communication System: IEEE 802.11b; Frequency: 2412 MHz; Duty Cycle: 1:1

Medium: BSL2450 ($\sigma = 1.98$ mho/m, $\epsilon_r = 51.3$, $\rho = 1000$ kg/m³)

Air Temperature 25.3 deg C ; Liquid Temperature 24.3 deg C

Phantom section: Flat Section

DASY4 Configuration:

- Probe: ET3DV6 - SN1762; ConvF(4.6, 4.6, 4.6); Calibrated: 3/31/2003
- Sensor-Surface: 4mm (Mechanical Surface Detection)
Sensor-Surface: 0mm (Fix Surface)
- Electronics: DAE3 Sn558; Calibrated: 3/7/2003
- Phantom: SAM 34; Type: SAM V4.0; Serial: TP-1150
- Measurement SW: DASY4, V4.1 Build 47; Postprocessing SW: SEMCAD, V1.8 Build 62

Low Rate=11M bit/Area Scan (6x6x1): Measurement grid: dx=15mm, dy=15mm

Reference Value = 12.7 V/m

Power Drift = -0.1 dB

Maximum value of SAR = 0.253 mW/g

Low Rate=11M bit/Z Scan (1x1x21): Measurement grid: dx=20mm, dy=20mm, dz=5mm

Reference Value = 12.7 V/m

Power Drift = -0.1 dB

Maximum value of SAR = 0.239 mW/g

Low Rate=11M bit/Zoom Scan (5x5x7)/Cube 0: Measurement grid: dx=7.5mm, dy=7.5mm, dz=5mm

Peak SAR (extrapolated) = 0.549 W/kg

SAR(1 g) = 0.271 mW/g; SAR(10 g) = 0.148 mW/g

Reference Value = 12.7 V/m

Power Drift = -0.1 dB

Maximum value of SAR = 0.293 mW/g

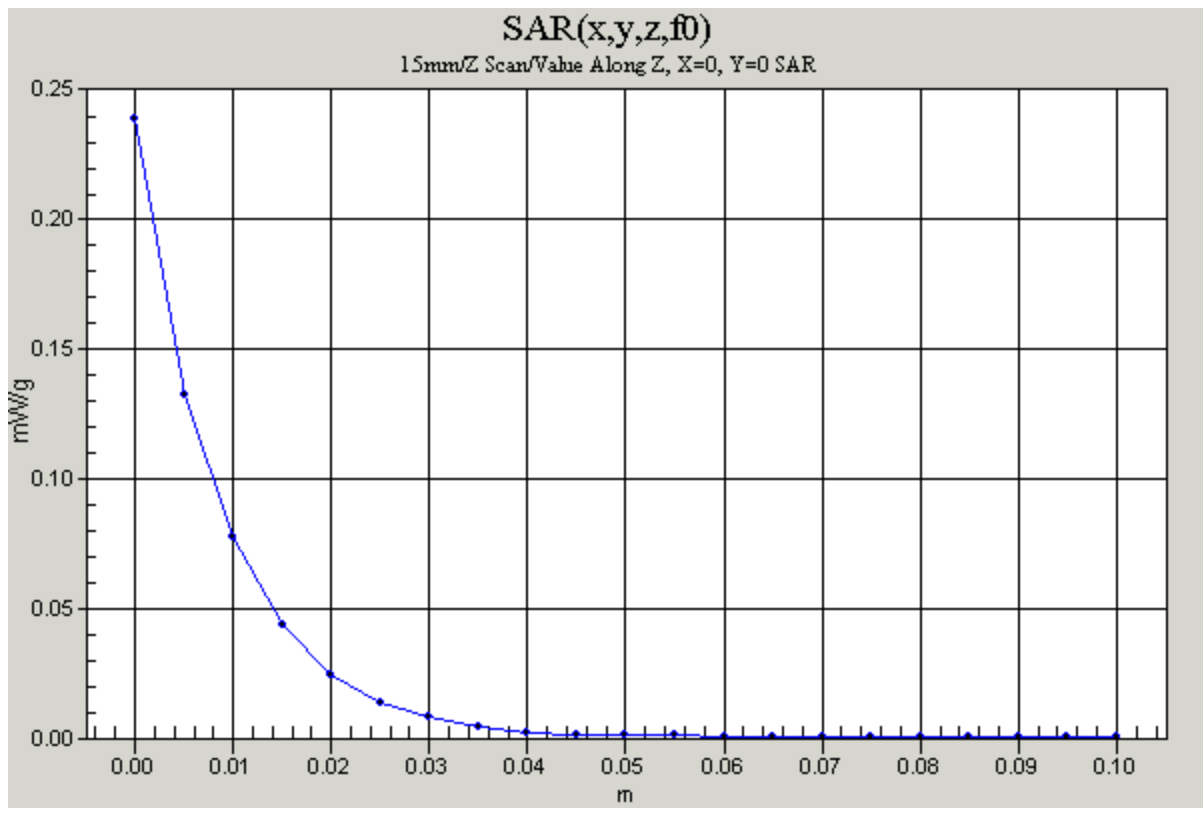
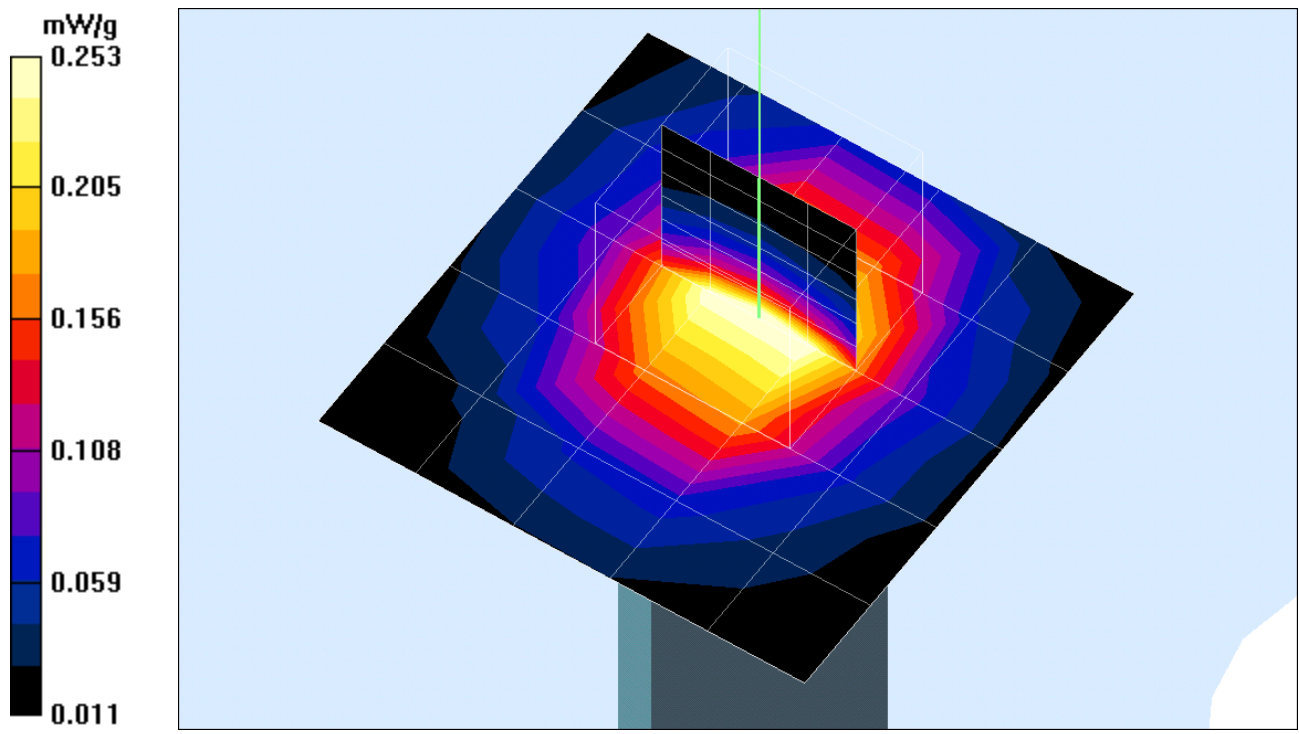

Test Laboratory: Compliance Certification Services Inc.

15mm mode(with Compaq)

DUT: 802.11b Wireless LAN Cardbus Card ; Type: 11-36; Serial: N/A

Communication System: IEEE 802.11b; Frequency: 2437 MHz; Duty Cycle: 1:1

Medium: BSL2450 ($\sigma = 1.98$ mho/m, $\epsilon_r = 51.3$, $\rho = 1000$ kg/m³)

Air Temperature 25.3 deg C ; Liquid Temperature 24.3 deg C

Phantom section: Flat Section

DASY4 Configuration:

- Probe: ET3DV6 - SN1762; ConvF(4.6, 4.6, 4.6); Calibrated: 3/31/2003
- Sensor-Surface: 4mm (Mechanical Surface Detection)
Sensor-Surface: 0mm (Fix Surface)
- Electronics: DAE3 Sn558; Calibrated: 3/7/2003
- Phantom: SAM 34; Type: SAM V4.0; Serial: TP-1150
- Measurement SW: DASY4, V4.1 Build 47; Postprocessing SW: SEMCAD, V1.8 Build 62

mid Rate=11M bit/Area Scan (6x6x1): Measurement grid: dx=15mm, dy=15mm

Reference Value = 12.5 V/m

Power Drift = -0.1 dB

Maximum value of SAR = 0.271 mW/g

mid Rate=11M bit/Z Scan (1x1x21): Measurement grid: dx=20mm, dy=20mm, dz=5mm

Reference Value = 12.5 V/m

Power Drift = -0.1 dB

Maximum value of SAR = 0.234 mW/g

mid Rate=11M bit/Zoom Scan (5x5x7)/Cube 0: Measurement grid: dx=7.5mm, dy=7.5mm, dz=5mm

Peak SAR (extrapolated) = 0.537 W/kg

SAR(1 g) = 0.267 mW/g; SAR(10 g) = 0.145 mW/g

Reference Value = 12.5 V/m

Power Drift = -0.1 dB

Maximum value of SAR = 0.288 mW/g

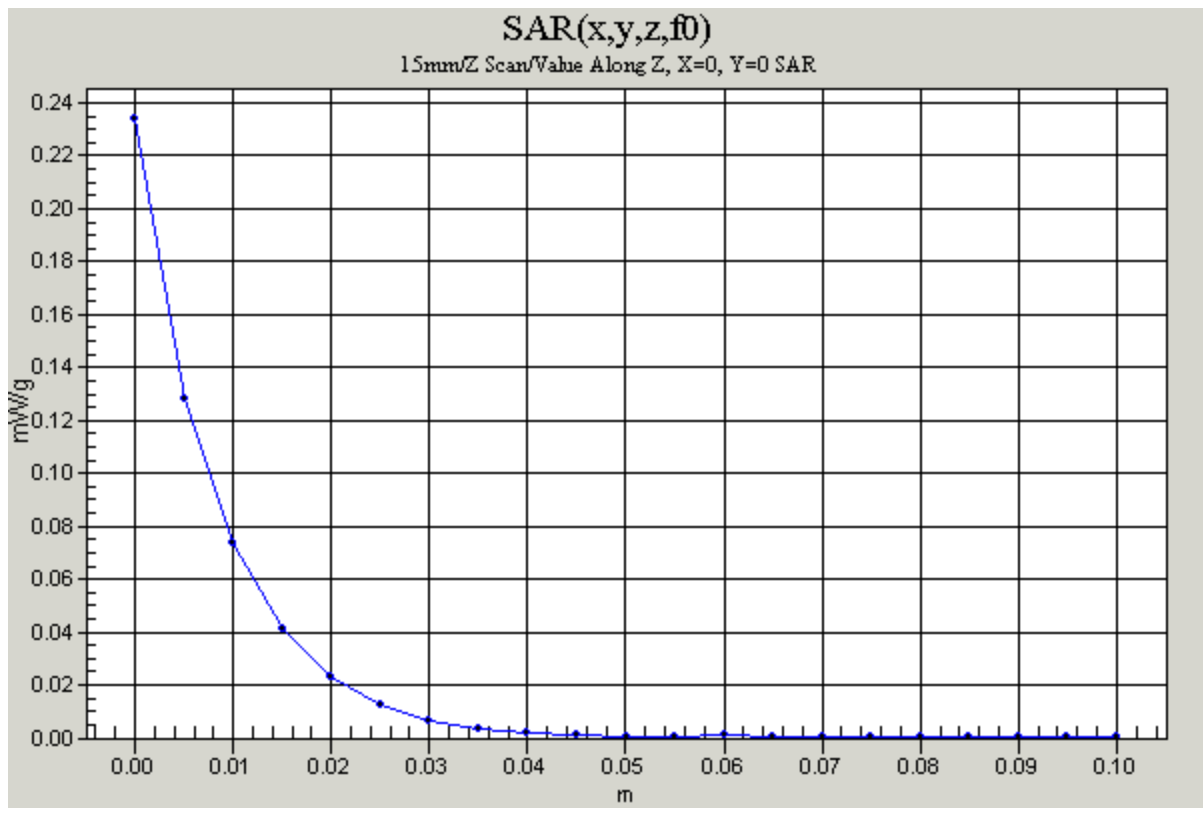
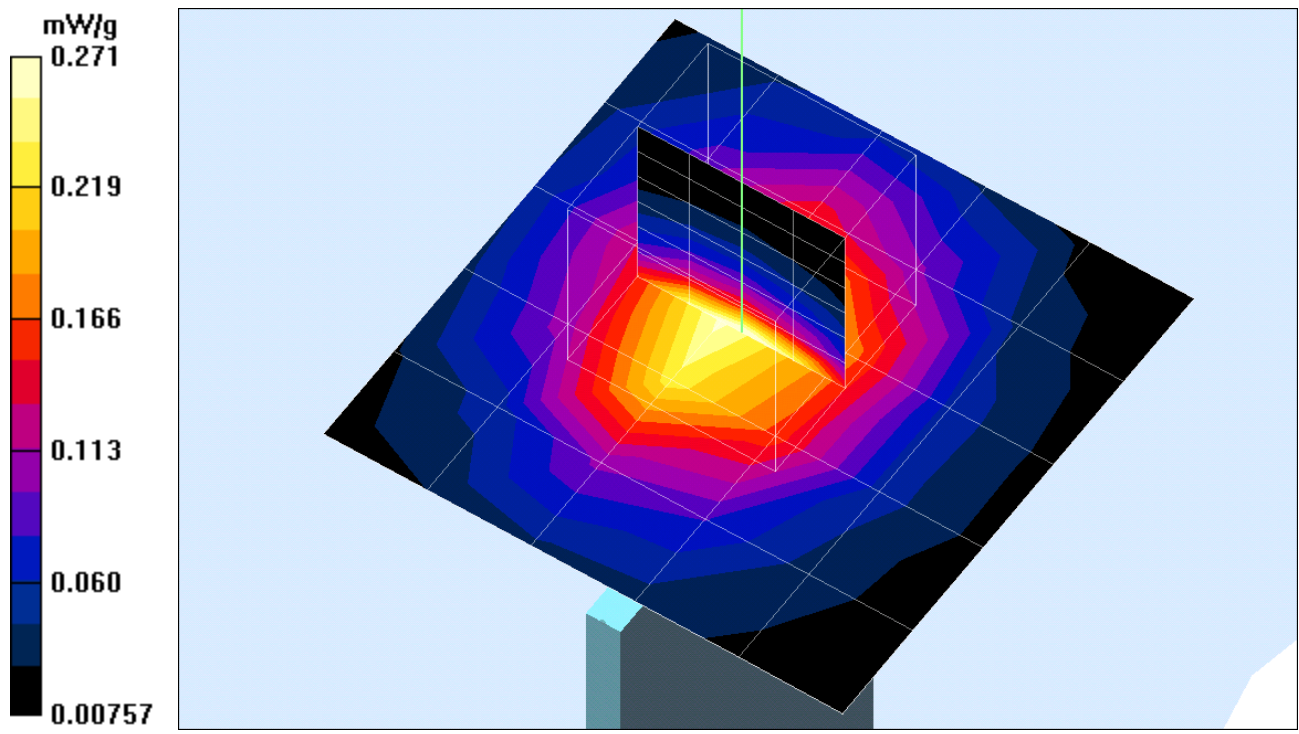

Test Laboratory: Compliance Certification Services Inc.

15mm mode(with Compaq)

DUT: 802.11b Wireless LAN Cardbus Card ; Type: 11-36; Serial: N/A

Communication System: IEEE 802.11b; Frequency: 2462 MHz; Duty Cycle: 1:1

Medium: BSL2450 ($\sigma = 1.98$ mho/m, $\epsilon_r = 51.3$, $\rho = 1000$ kg/m³)

Air Temperature 25.3 deg C ; Liquid Temperature 24.3 deg C

Phantom section: Flat Section

DASY4 Configuration:

- Probe: ET3DV6 - SN1762; ConvF(4.6, 4.6, 4.6); Calibrated: 3/31/2003
- Sensor-Surface: 4mm (Mechanical Surface Detection)
Sensor-Surface: 0mm (Fix Surface)
- Electronics: DAE3 Sn558; Calibrated: 3/7/2003
- Phantom: SAM 34; Type: SAM V4.0; Serial: TP-1150
- Measurement SW: DASY4, V4.1 Build 47; Postprocessing SW: SEMCAD, V1.8 Build 62

High Rate=11M bit/Area Scan (6x6x1): Measurement grid: dx=15mm, dy=15mm

Reference Value = 11.5 V/m

Power Drift = -0.1 dB

Maximum value of SAR = 0.232 mW/g

High Rate=11M bit/Z Scan (1x1x21): Measurement grid: dx=20mm, dy=20mm, dz=5mm

Reference Value = 11.5 V/m

Power Drift = -0.1 dB

Maximum value of SAR = 0.200 mW/g

High Rate=11M bit/Zoom Scan (5x5x7)/Cube 0: Measurement grid: dx=7.5mm, dy=7.5mm, dz=5mm

Peak SAR (extrapolated) = 0.464 W/kg

SAR(1 g) = 0.226 mW/g; SAR(10 g) = 0.122 mW/g

Reference Value = 11.5 V/m

Power Drift = -0.1 dB

Maximum value of SAR = 0.246 mW/g

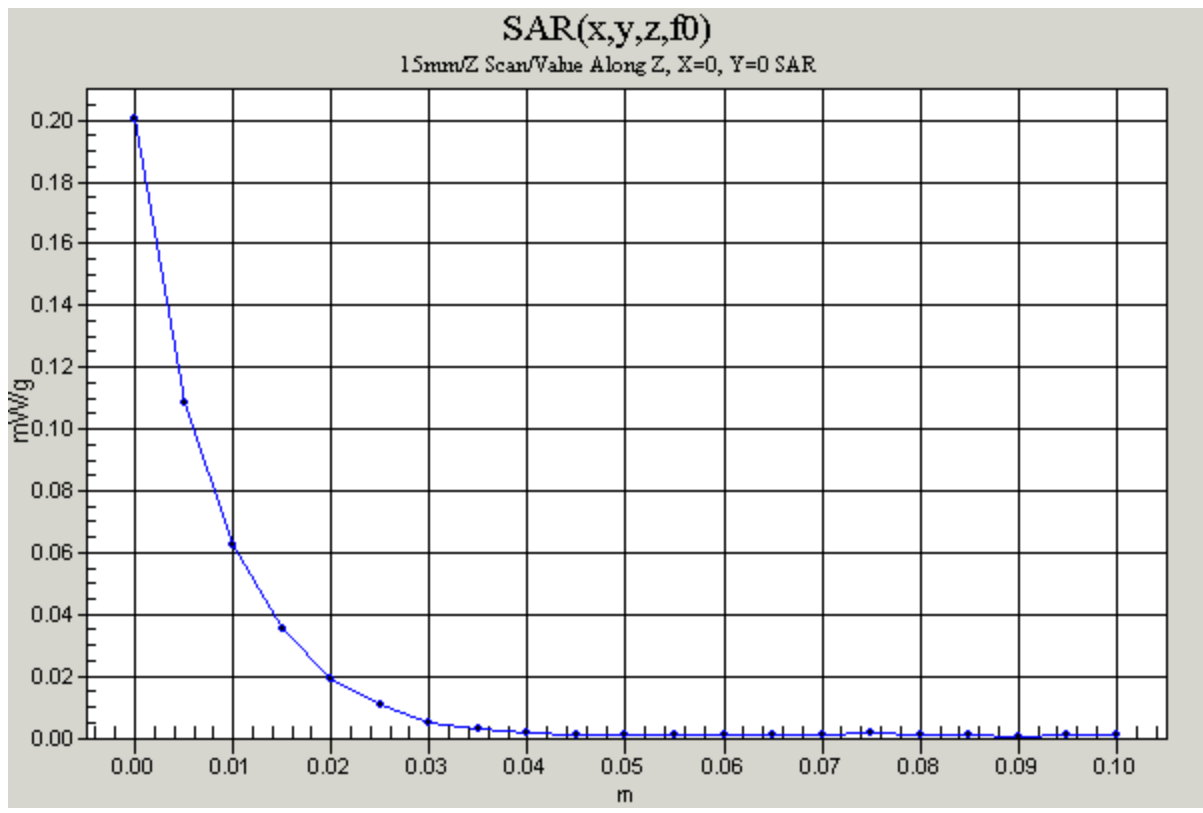
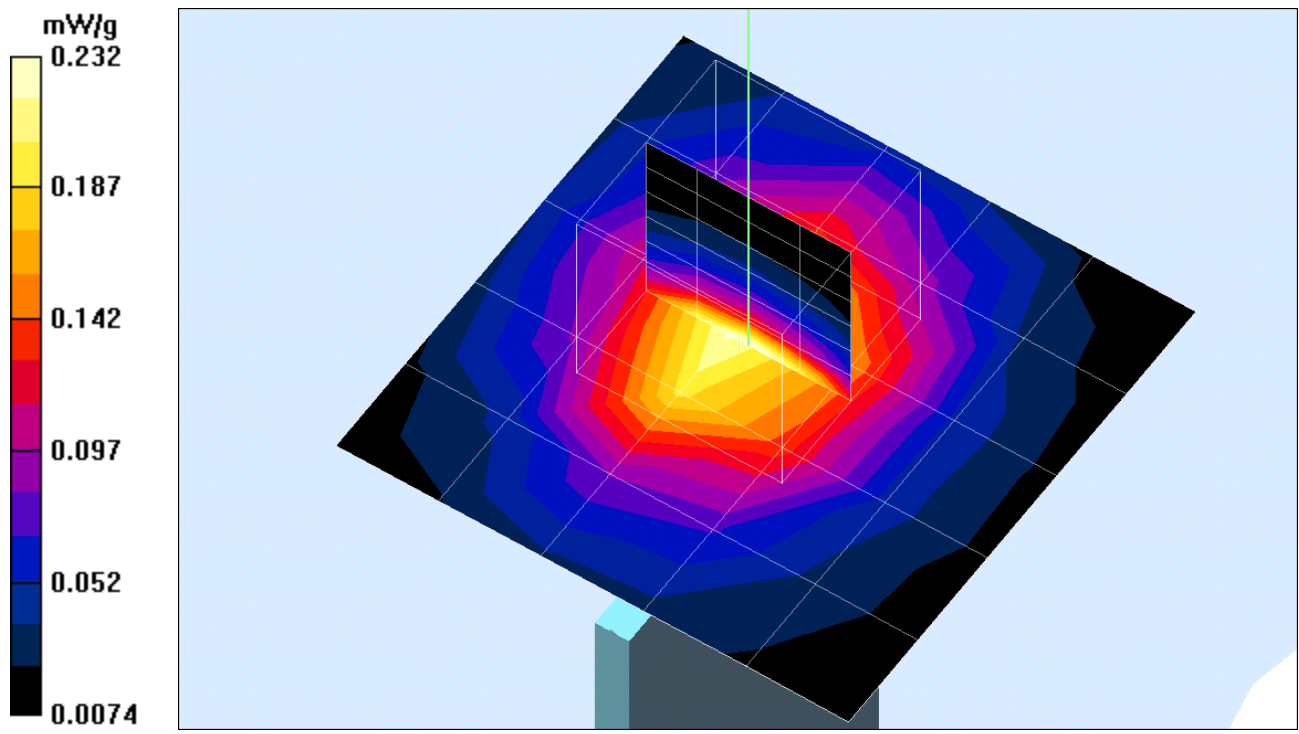

Test Laboratory: Compliance Certification Services Inc.

15mm mode(with IBM-R31)

DUT: 802.11b Wireless LAN Cardbus PC Card ; Type: WB2550; Serial: N/A

Communication System: IEEE 802.11b; Frequency: 2412 MHz; Duty Cycle: 1:1

Medium: BSL2450 ($\sigma = 1.98$ mho/m, $\epsilon_r = 51.3$, $\rho = 1000$ kg/m³)

Air Temperature 25.3 deg C ; Liquid Temperature 24.3 deg C

Phantom section: Flat Section

DASY4 Configuration:

- Probe: ET3DV6 - SN1762; ConvF(4.6, 4.6, 4.6); Calibrated: 3/31/2003
- Sensor-Surface: 4mm (Mechanical Surface Detection)
Sensor-Surface: 0mm (Fix Surface)
- Electronics: DAE3 Sn558; Calibrated: 3/7/2003
- Phantom: SAM 34; Type: SAM V4.0; Serial: TP-1150
- Measurement SW: DASY4, V4.1 Build 47; Postprocessing SW: SEMCAD, V1.8 Build 62

Low Rate=11M bit/Area Scan (7x7x1): Measurement grid: dx=15mm, dy=15mm

Reference Value = 11.8 V/m

Power Drift = -0.1 dB

Maximum value of SAR = 0.215 mW/g

Low Rate=11M bit/Z Scan (1x1x21): Measurement grid: dx=20mm, dy=20mm, dz=5mm

Reference Value = 11.8 V/m

Power Drift = -0.1 dB

Maximum value of SAR = 0.209 mW/g

Low Rate=11M bit/Zoom Scan (5x5x7)/Cube 0: Measurement grid: dx=7.5mm, dy=7.5mm, dz=5mm

Peak SAR (extrapolated) = 0.472 W/kg

SAR(1 g) = 0.234 mW/g; SAR(10 g) = 0.128 mW/g

Reference Value = 11.8 V/m

Power Drift = -0.1 dB

Maximum value of SAR = 0.253 mW/g

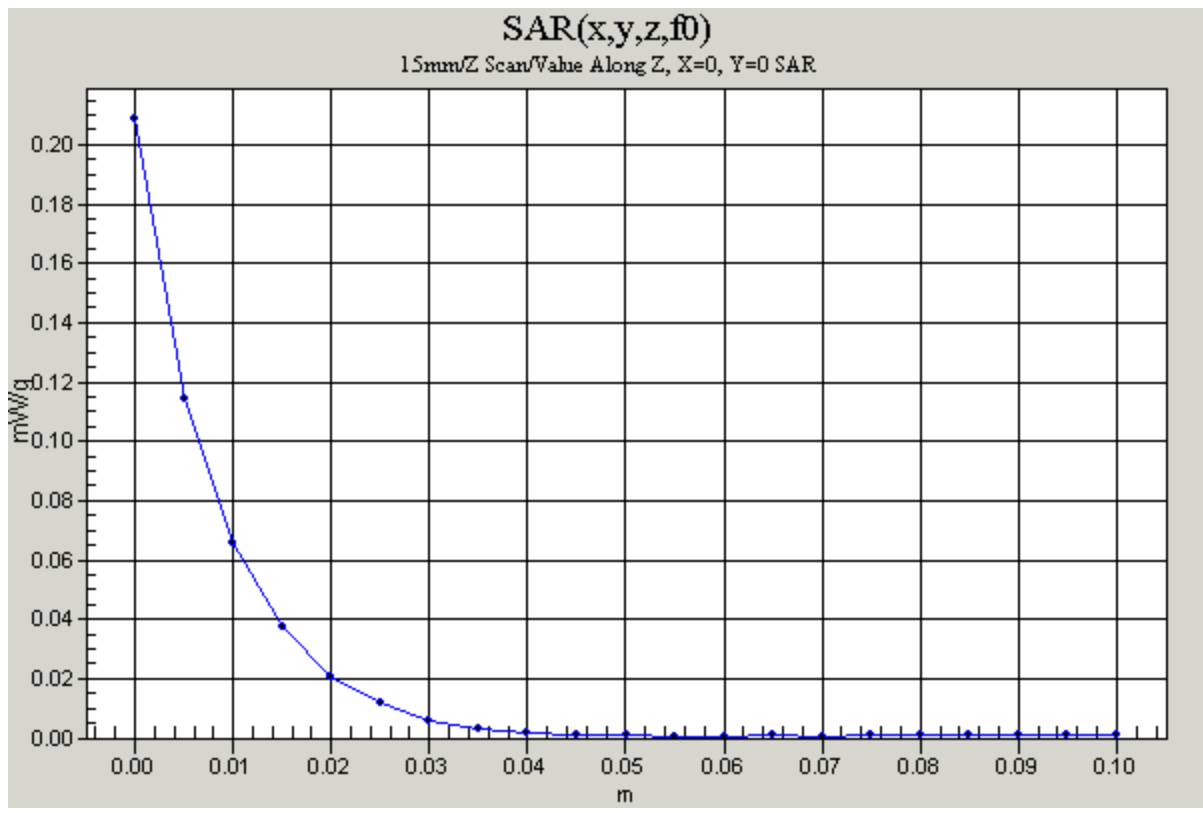
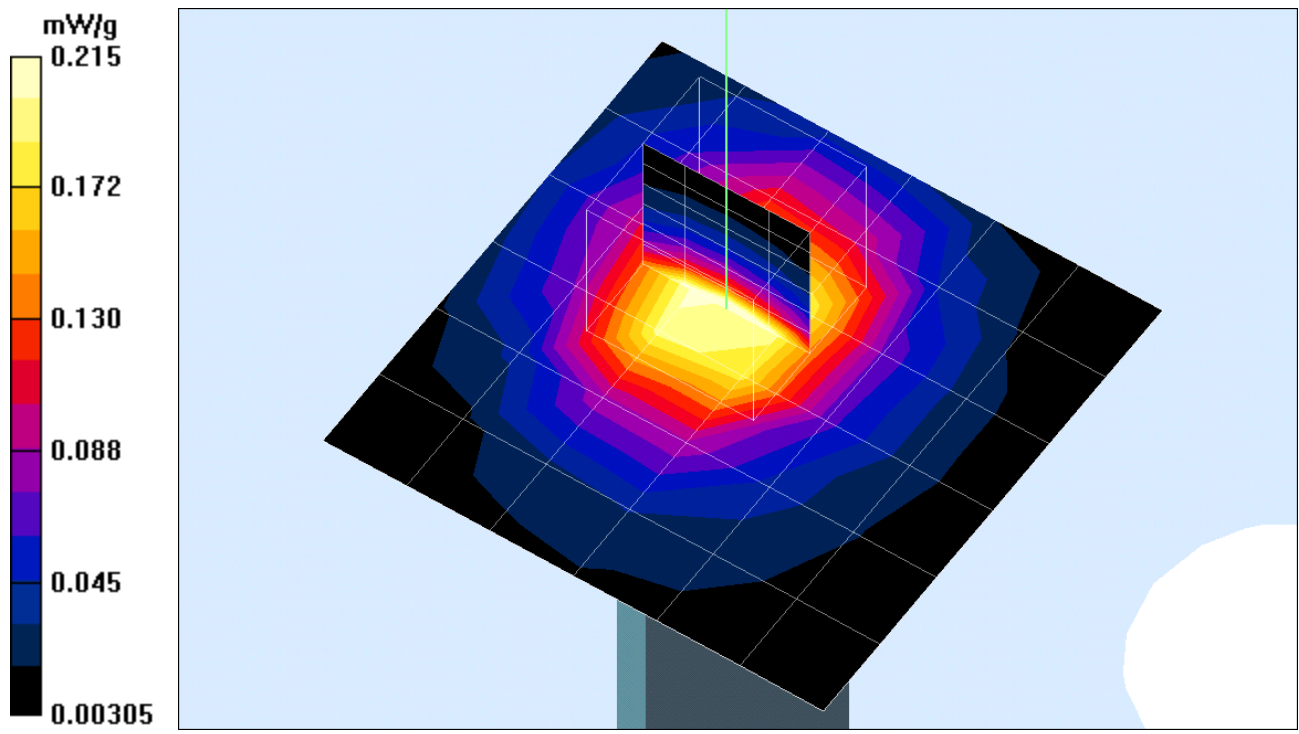

Test Laboratory: Compliance Certification Services Inc.

15mm mode(with IBM-R31)

DUT: 802.11b Wireless LAN Cardbus Card ; Type: WB2550; Serial: N/A

Communication System: IEEE 802.11b; Frequency: 2437 MHz; Duty Cycle: 1:1

Medium: BSL2450 ($\sigma = 1.98$ mho/m, $\epsilon_r = 51.3$, $\rho = 1000$ kg/m³)

Air Temperature 25.3 deg C ; Liquid Temperature 24.3 deg C

Phantom section: Flat Section

DASY4 Configuration:

- Probe: ET3DV6 - SN1762; ConvF(4.6, 4.6, 4.6); Calibrated: 3/31/2003
- Sensor-Surface: 4mm (Mechanical Surface Detection)
Sensor-Surface: 0mm (Fix Surface)
- Electronics: DAE3 Sn558; Calibrated: 3/7/2003
- Phantom: SAM 34; Type: SAM V4.0; Serial: TP-1150
- Measurement SW: DASY4, V4.1 Build 47; Postprocessing SW: SEMCAD, V1.8 Build 62

mid Rate=11M bit/Area Scan (6x6x1): Measurement grid: dx=15mm, dy=15mm

Reference Value = 11.8 V/m

Power Drift = -0.1 dB

Maximum value of SAR = 0.253 mW/g

mid Rate=11M bit/Z Scan (1x1x21): Measurement grid: dx=20mm, dy=20mm, dz=5mm

Reference Value = 11.8 V/m

Power Drift = -0.1 dB

Maximum value of SAR = 0.215 mW/g

mid Rate=11M bit/Zoom Scan (5x5x7)/Cube 0: Measurement grid: dx=7.5mm, dy=7.5mm, dz=5mm

Peak SAR (extrapolated) = 0.505 W/kg

SAR(1 g) = 0.246 mW/g; SAR(10 g) = 0.133 mW/g

Reference Value = 11.8 V/m

Power Drift = -0.1 dB

Maximum value of SAR = 0.264 mW/g

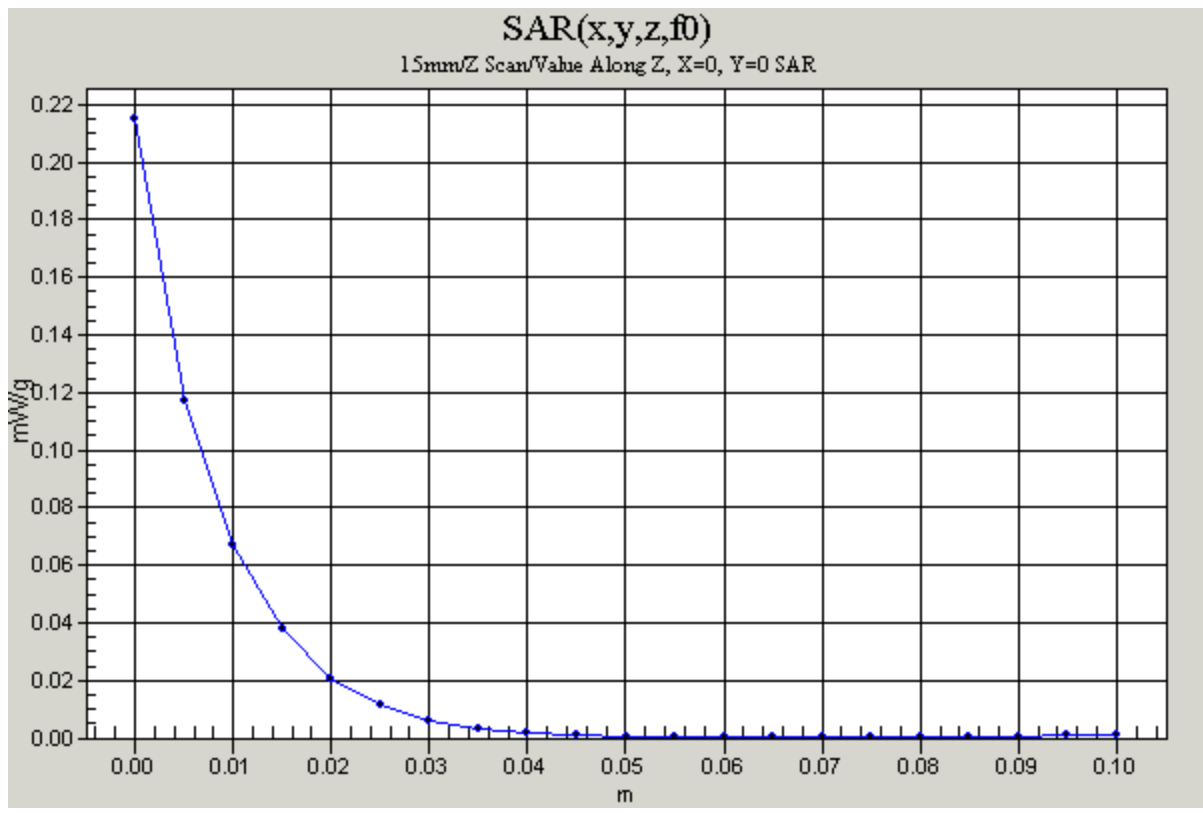
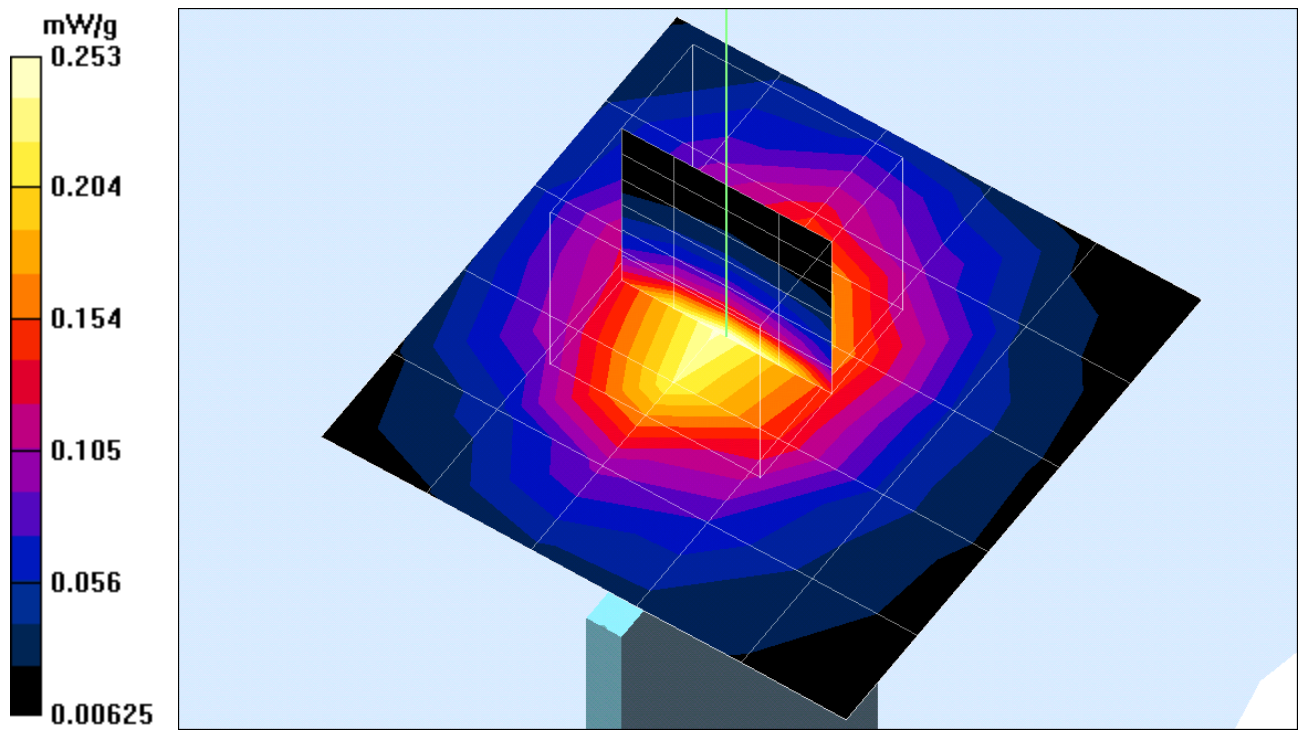

Test Laboratory: Compliance Certification Services Inc.

15mm mode(with IBM-R31)

DUT: 802.11b Wireless LAN Cardbus Card ; Type: WB2550; Serial: N/A

Communication System: IEEE 802.11b; Frequency: 2462 MHz; Duty Cycle: 1:1

Medium: BSL2450 ($\sigma = 1.98$ mho/m, $\epsilon_r = 51.3$, $\rho = 1000$ kg/m³)

Air Temperature 25.3 deg C ; Liquid Temperature 24.3 deg C

Phantom section: Flat Section

DASY4 Configuration:

- Probe: ET3DV6 - SN1762; ConvF(4.6, 4.6, 4.6); Calibrated: 3/31/2003
- Sensor-Surface: 4mm (Mechanical Surface Detection)
Sensor-Surface: 0mm (Fix Surface)
- Electronics: DAE3 Sn558; Calibrated: 3/7/2003
- Phantom: SAM 34; Type: SAM V4.0; Serial: TP-1150
- Measurement SW: DASY4, V4.1 Build 47; Postprocessing SW: SEMCAD, V1.8 Build 62

High Rate=11M bit/Area Scan (6x6x1): Measurement grid: dx=15mm, dy=15mm

Reference Value = 11.4 V/m

Power Drift = -0.1 dB

Maximum value of SAR = 0.231 mW/g

High Rate=11M bit/Z Scan (1x1x21): Measurement grid: dx=20mm, dy=20mm, dz=5mm

Reference Value = 11.4 V/m

Power Drift = -0.1 dB

Maximum value of SAR = 0.194 mW/g

High Rate=11M bit/Zoom Scan (5x5x7)/Cube 0: Measurement grid: dx=7.5mm, dy=7.5mm, dz=5mm

Peak SAR (extrapolated) = 0.460 W/kg

SAR(1 g) = 0.223 mW/g; SAR(10 g) = 0.120 mW/g

Reference Value = 11.4 V/m

Power Drift = -0.1 dB

Maximum value of SAR = 0.241 mW/g

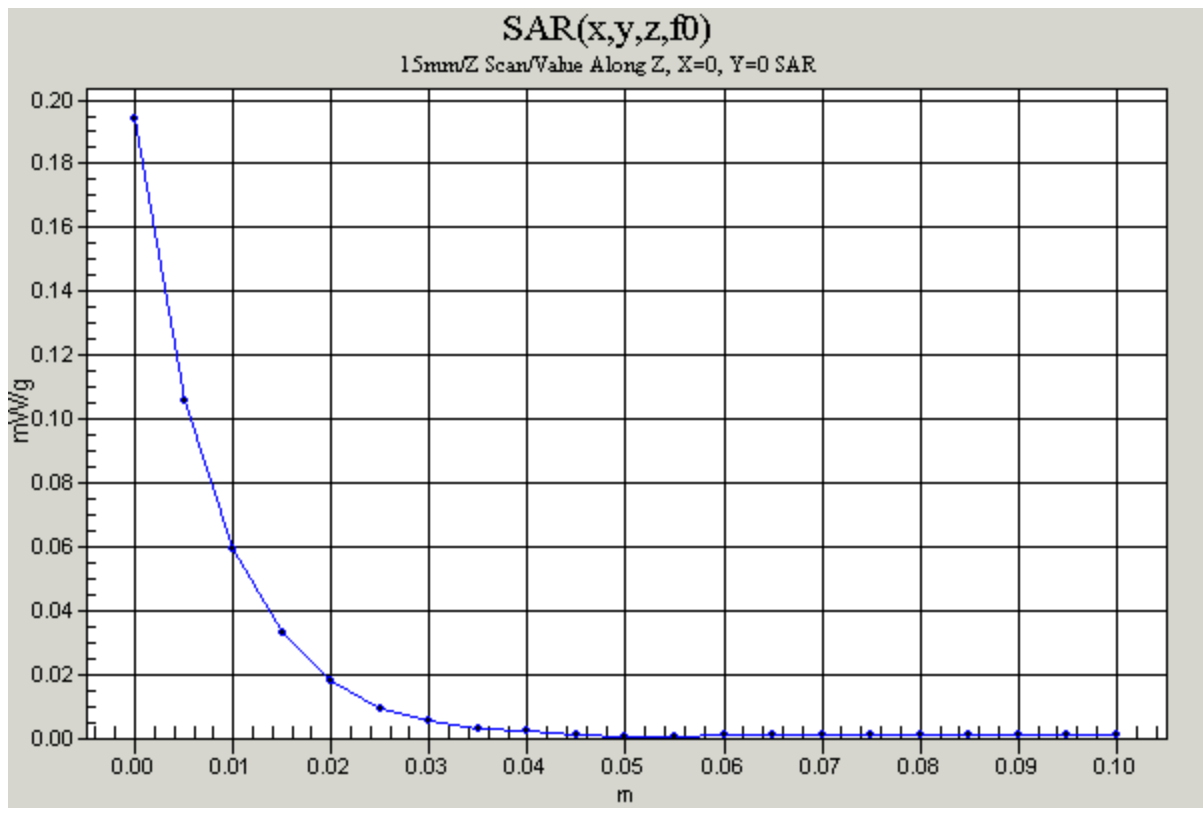
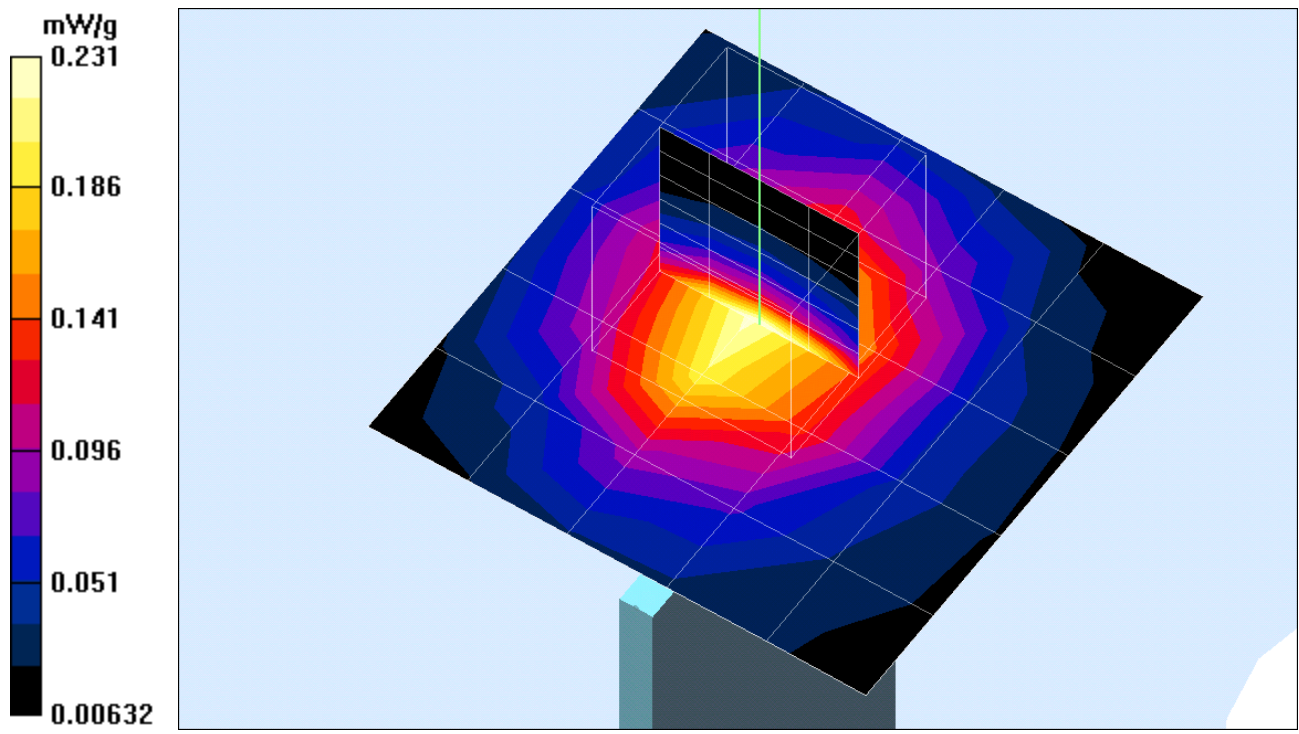

Test Laboratory: Compliance Certification Services Inc.

15mm mode(with IBM)

DUT: 802.11b Wireless LAN Cardbus Card ; Type: 11-36; Serial: N/A

Communication System: IEEE 802.11b; Frequency: 2412 MHz; Duty Cycle: 1:1

Medium: BSL2450 ($\sigma = 1.98$ mho/m, $\epsilon_r = 51.3$, $\rho = 1000$ kg/m³)

Air Temperature 25.3 deg C ; Liquid Temperature 24.3 deg C

Phantom section: Flat Section

DASY4 Configuration:

- Probe: ET3DV6 - SN1762; ConvF(4.6, 4.6, 4.6); Calibrated: 3/31/2003
- Sensor-Surface: 4mm (Mechanical Surface Detection)
Sensor-Surface: 0mm (Fix Surface)
- Electronics: DAE3 Sn558; Calibrated: 3/7/2003
- Phantom: SAM 34; Type: SAM V4.0; Serial: TP-1150
- Measurement SW: DASY4, V4.1 Build 47; Postprocessing SW: SEMCAD, V1.8 Build 62

Low Rate=11M bit/Area Scan (6x6x1): Measurement grid: dx=15mm, dy=15mm

Reference Value = 12.9 V/m

Power Drift = -0.1 dB

Maximum value of SAR = 0.252 mW/g

Low Rate=11M bit/Z Scan (1x1x21): Measurement grid: dx=20mm, dy=20mm, dz=5mm

Reference Value = 12.9 V/m

Power Drift = -0.1 dB

Maximum value of SAR = 0.242 mW/g

Low Rate=11M bit/Zoom Scan (5x5x7)/Cube 0: Measurement grid: dx=7.5mm, dy=7.5mm, dz=5mm

Peak SAR (extrapolated) = 0.568 W/kg

SAR(1 g) = 0.277 mW/g; SAR(10 g) = 0.147 mW/g

Reference Value = 12.9 V/m

Power Drift = -0.1 dB

Maximum value of SAR = 0.298 mW/g

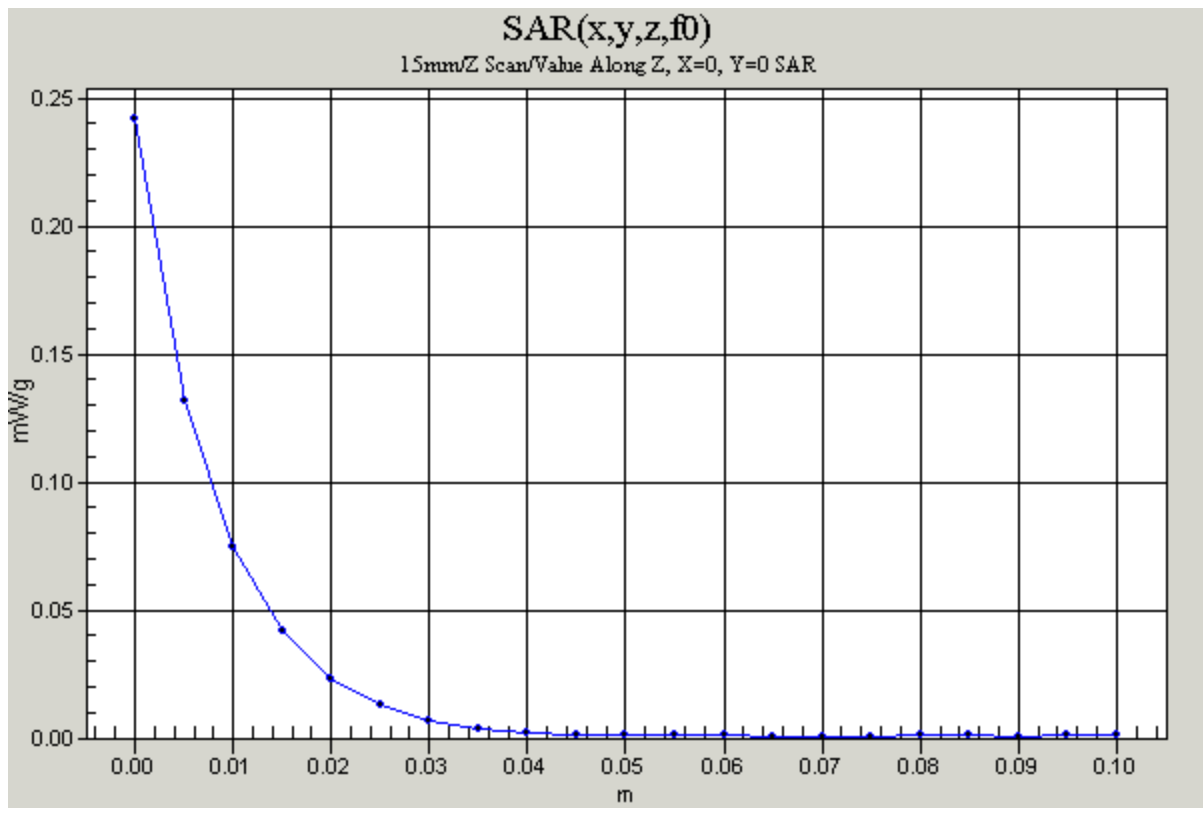
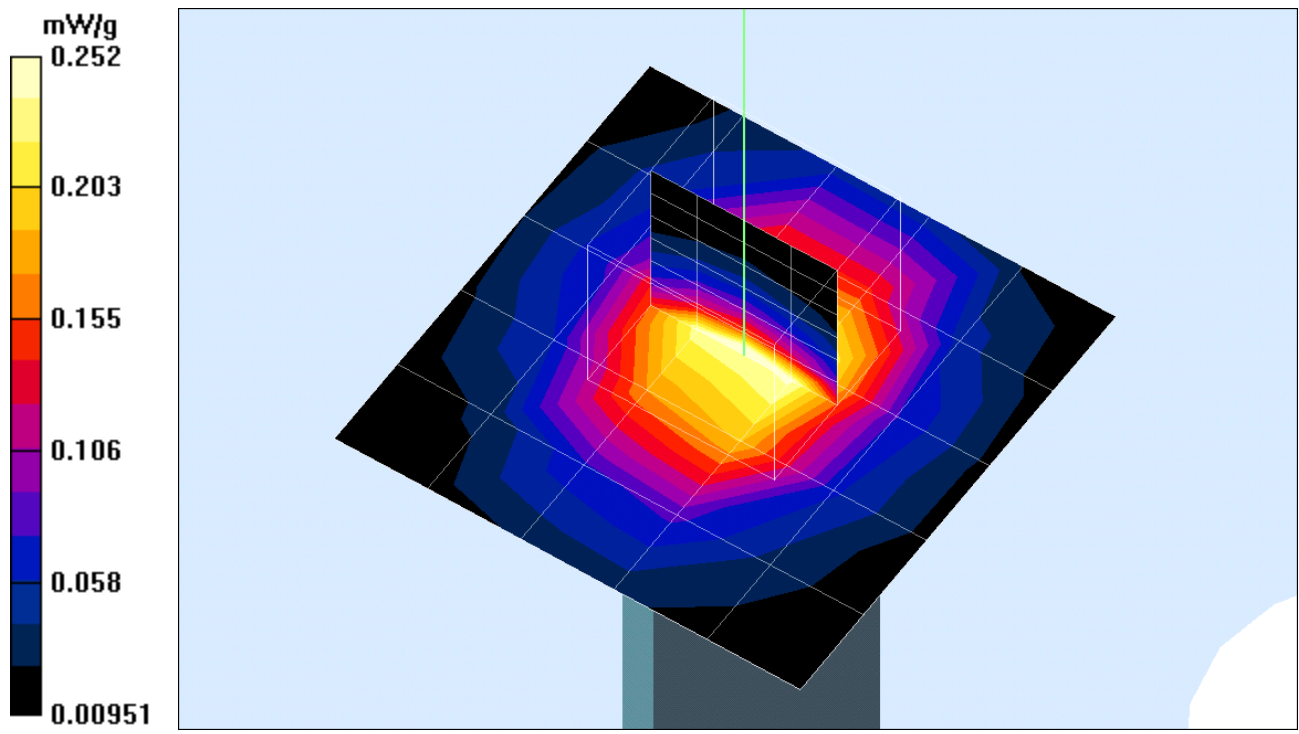

Test Laboratory: Compliance Certification Services Inc.

15mm mode(with IBM)

DUT: 802.11b Wireless LAN Cardbus Card ; Type: 11-36; Serial: N/A

Communication System: IEEE 802.11b; Frequency: 2437 MHz; Duty Cycle: 1:1

Medium: BSL2450 ($\sigma = 1.98$ mho/m, $\epsilon_r = 51.3$, $\rho = 1000$ kg/m³)

Air Temperature 25.3 deg C ; Liquid Temperature 24.3 deg C

Phantom section: Flat Section

DASY4 Configuration:

- Probe: ET3DV6 - SN1762; ConvF(4.6, 4.6, 4.6); Calibrated: 3/31/2003
- Sensor-Surface: 4mm (Mechanical Surface Detection)
Sensor-Surface: 0mm (Fix Surface)
- Electronics: DAE3 Sn558; Calibrated: 3/7/2003
- Phantom: SAM 34; Type: SAM V4.0; Serial: TP-1150
- Measurement SW: DASY4, V4.1 Build 47; Postprocessing SW: SEMCAD, V1.8 Build 62

mid Rate=11M bit/Area Scan (6x6x1): Measurement grid: dx=15mm, dy=15mm

Reference Value = 13.3 V/m

Power Drift = -0.1 dB

Maximum value of SAR = 0.294 mW/g

mid Rate=11M bit/Z Scan (1x1x21): Measurement grid: dx=20mm, dy=20mm, dz=5mm

Reference Value = 13.3 V/m

Power Drift = -0.1 dB

Maximum value of SAR = 0.262 mW/g

mid Rate=11M bit/Zoom Scan (5x5x7)/Cube 0: Measurement grid: dx=7.5mm, dy=7.5mm, dz=5mm

Peak SAR (extrapolated) = 0.634 W/kg

SAR(1 g) = 0.303 mW/g; SAR(10 g) = 0.160 mW/g

Reference Value = 13.3 V/m

Power Drift = -0.1 dB

Maximum value of SAR = 0.326 mW/g

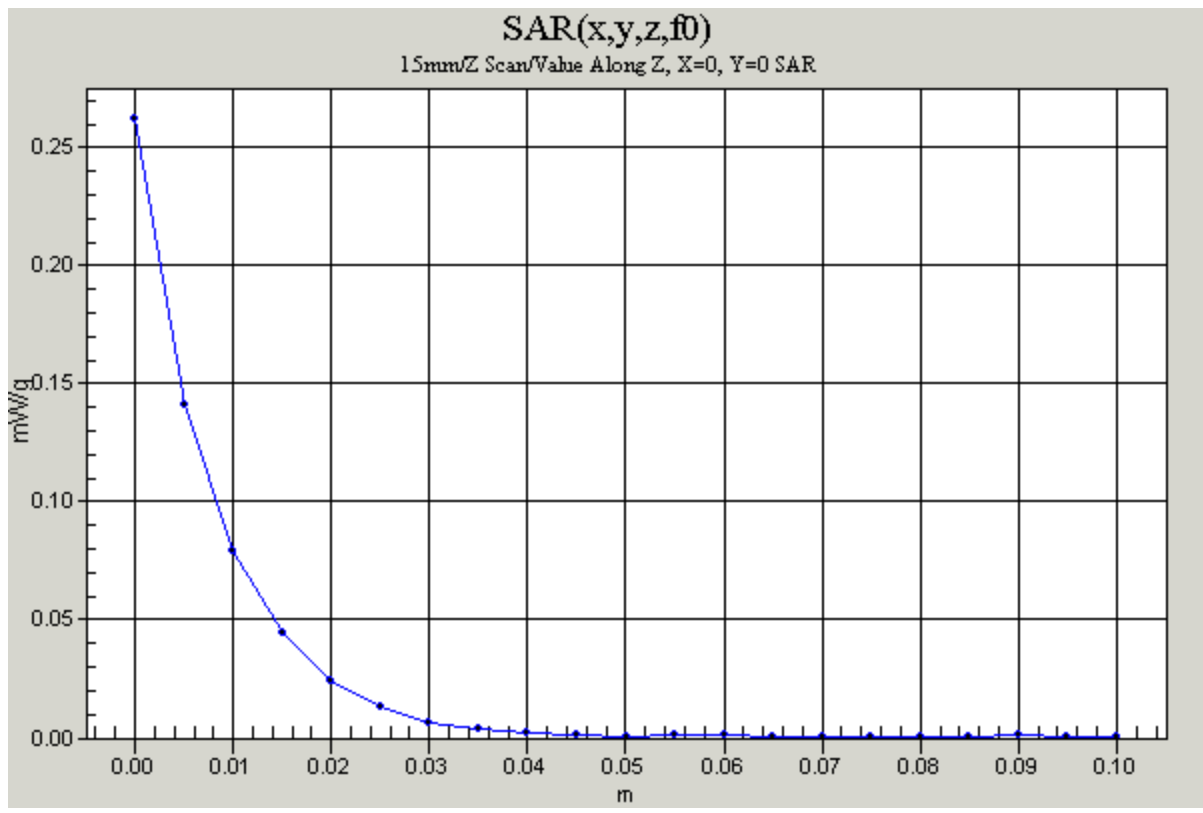
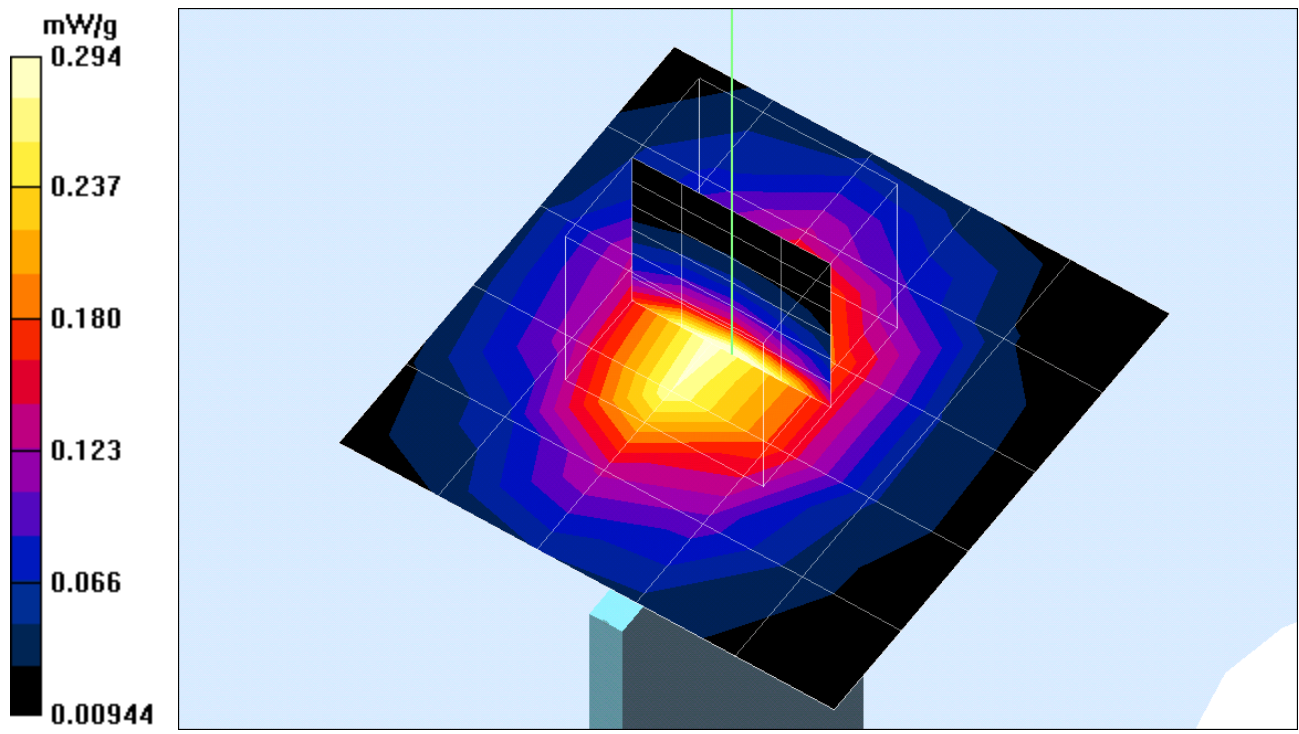

Test Laboratory: Compliance Certification Services Inc.

15mm mode(with IBM)

DUT: 802.11b Wireless LAN Cardbus Card ; Type: 11-36; Serial: N/A

Communication System: IEEE 802.11b; Frequency: 2462 MHz; Duty Cycle: 1:1

Medium: BSL2450 ($\sigma = 1.98$ mho/m, $\epsilon_r = 51.3$, $\rho = 1000$ kg/m³)

Air Temperature 25.3 deg C ; Liquid Temperature 24.3 deg C

Phantom section: Flat Section

DASY4 Configuration:

- Probe: ET3DV6 - SN1762; ConvF(4.6, 4.6, 4.6); Calibrated: 3/31/2003
- Sensor-Surface: 4mm (Mechanical Surface Detection)
Sensor-Surface: 0mm (Fix Surface)
- Electronics: DAE3 Sn558; Calibrated: 3/7/2003
- Phantom: SAM 34; Type: SAM V4.0; Serial: TP-1150
- Measurement SW: DASY4, V4.1 Build 47; Postprocessing SW: SEMCAD, V1.8 Build 62

High Rate=11M bit/Area Scan (6x6x1): Measurement grid: dx=15mm, dy=15mm

Reference Value = 12.7 V/m

Power Drift = 0.1 dB

Maximum value of SAR = 0.272 mW/g

High Rate=11M bit/Z Scan (1x1x21): Measurement grid: dx=20mm, dy=20mm, dz=5mm

Reference Value = 12.7 V/m

Power Drift = 0.1 dB

Maximum value of SAR = 0.241 mW/g

High Rate=11M bit/Zoom Scan (5x5x7)/Cube 0: Measurement grid: dx=7.5mm, dy=7.5mm, dz=5mm

Peak SAR (extrapolated) = 0.578 W/kg

SAR(1 g) = 0.277 mW/g; SAR(10 g) = 0.146 mW/g

Reference Value = 12.7 V/m

Power Drift = 0.1 dB

Maximum value of SAR = 0.296 mW/g

