

Schrift: Akkurat Light Italic
Schriftgröße: 2 mm, kursiv

TEXT = RWR95.51-A-SP
RWR95.51-R-SP
RWR95.51-R-SP-PT
RWR95.51-R-DP

Placeholder for HVIN.
Will be lasered individually for each device.

Schrift: Akkurat Italic Pro
Schriftgröße: 4,5 mm

Schrift: Akkurat Italic Pro
Schriftgröße: 4,5 mm

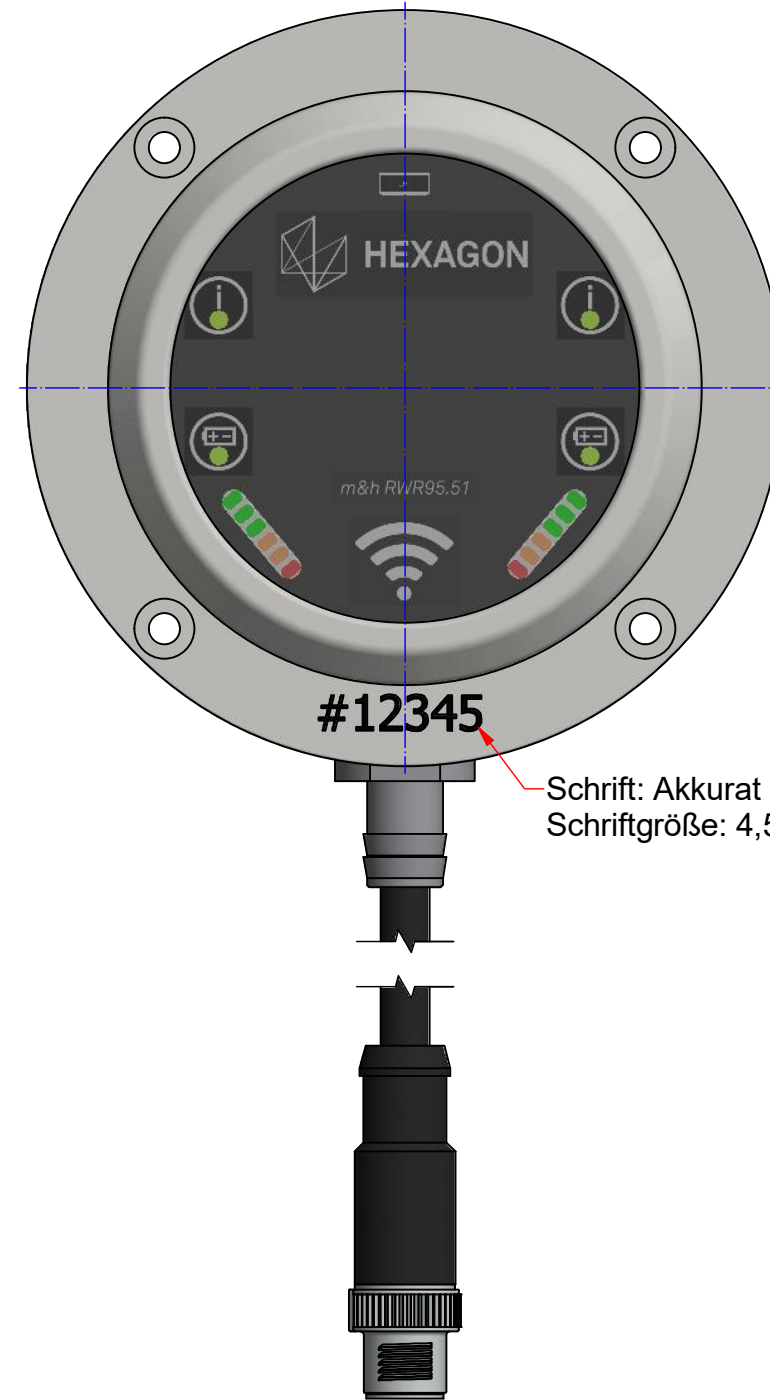
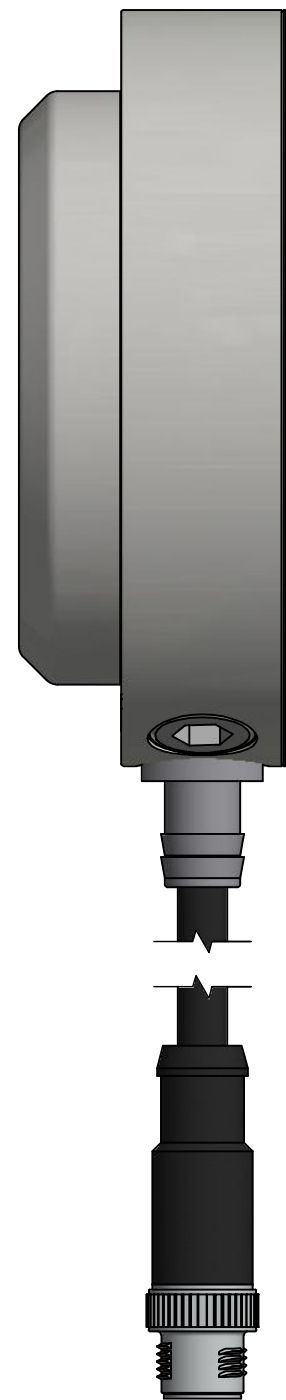
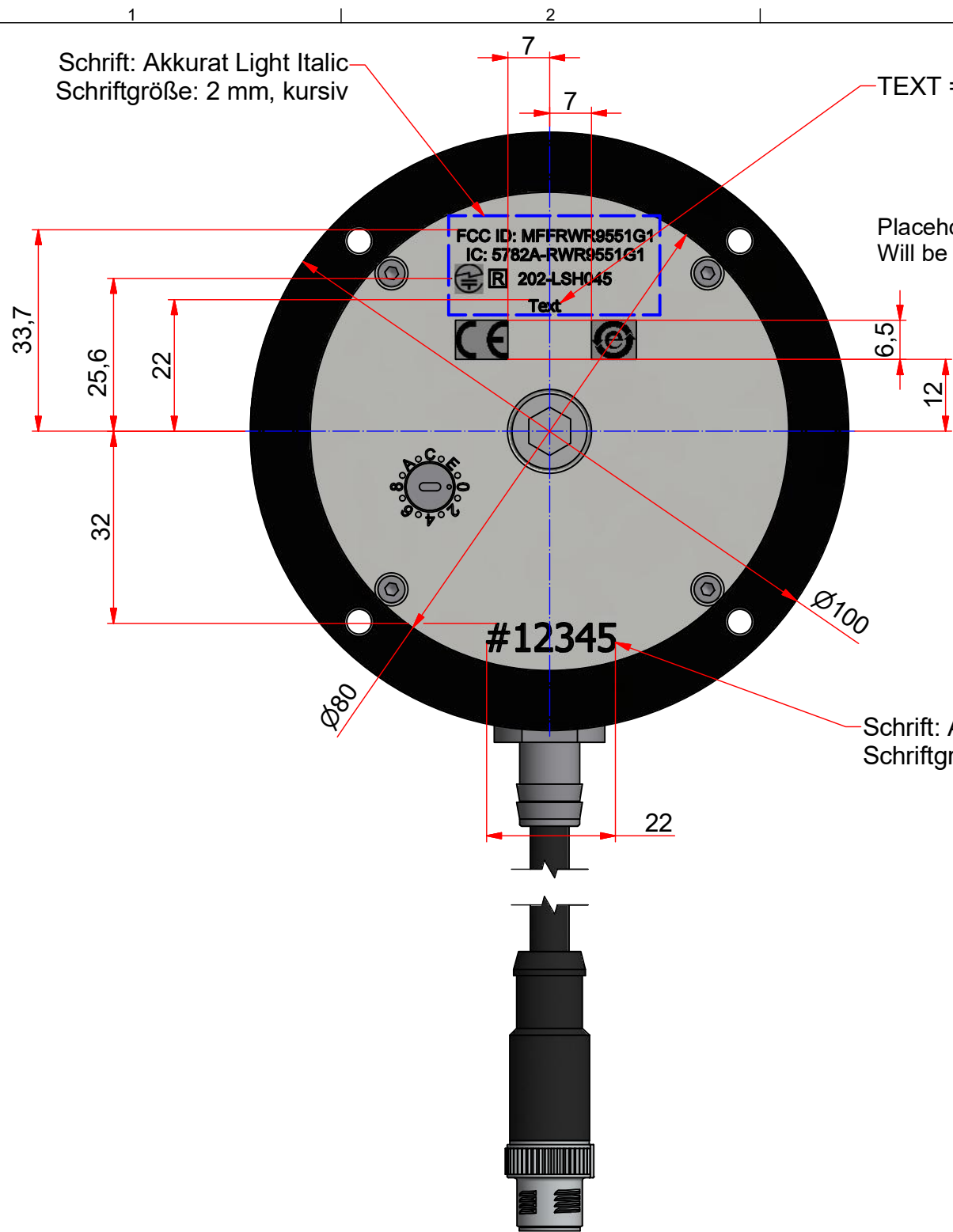

Customers confirmation:

Drawing and dimensions approved: _____ (signature and company stamp)

Alle Rechte nach DIN 34 vorbehalten. Unzulässige Weitergabe an Dritte verboten. Copyright m&h ©				Maßstab 1 : 1		m&h Teilnr.			
				Werkstoff					
Toleranzen ISO 2768 fein				Bezeichnung RW License CASTOR Laserbeschriftung Revision Level: 02					
								Datum	Name
								Bearbeitet	24.10.19
				Geprüft			Zeichnungsnummer 95.51-00.009		
m&h Inprocess Messtechnik GmbH Am Langholz 11 88289 Waldburg Germany www.mh-inprocess.com				Blatt Nr. 1					
Status	Änderungen	Datum	Name	Format A3					