

m&h RADIO-WAVE RECEIVER

RWR95.51

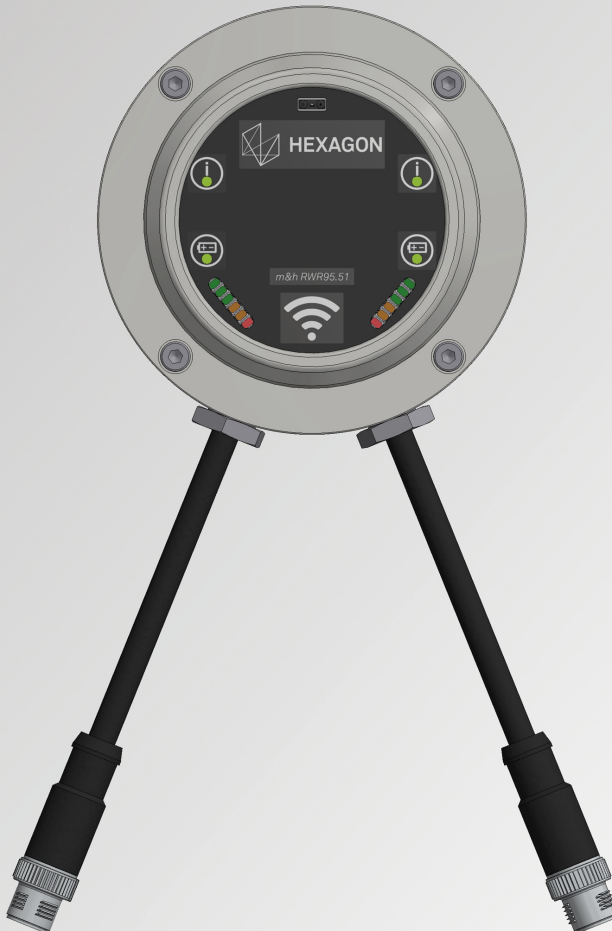

LANGUAGE	DESCRIPTION	PAGE
EN	OPERATING INSTRUCTIONS	3

Table of Contents

1	Description	5
1.1	General	5
1.1.1	Preface	5
1.1.2	Safety Instructions	5
1.1.3	Validity	6
1.2	Purpose.....	6
1.3	Declarations and Approvals.....	6
1.3.1	Europe (EC Declaration of Conformity)	6
1.3.2	USA (FCC Declaration)	6
1.3.3	Canada (IC /RSS Declaration)	6
1.3.4	China	6
1.3.5	Japan	7
1.4	System Components	8
1.5	Technical Data	9
1.6	Dimensions	9
1.6.1	Dimensions RWR95.51-R-SP	9
1.6.2	Dimensions RWR95.51-R-SP-PT	10
1.6.3	Dimensions RWR95.51-R-DP	11
1.6.4	Dimensions RWR95.51-A-SP	11
1.7	Transmission and Reception Area	12
1.8	Delivery Contents, Accessories and Spares	13
1.8.1	Delivery Contents	13
1.8.2	Accessories	13
1.8.3	Spares	14
2	Operation	15
2.1	Mounting	15
2.1.1	General Instructions for Mounting	15
2.1.2	Mounting RWR95.51-R-SP-PT	16
2.1.3	Mounting RWR95.51-R-SP/DP with Mounting Bracket (machine wall, internal).....	17
2.1.4	Mounting RWR95.51-A-SP, RWR95.51-R-SP/DP (machine wall, internal).....	18
2.1.5	Mounting RWR95.51-A-SP, RWR95.51-R-SP/DP (machine wall, internal).....	19
2.2	Connection	20
2.2.1	Electrical connection Single Probe versions	20
2.2.2	Electrical connection Dual Probe version	21
2.2.3	Overview of wire colours when using 95.51-STXX	21
2.2.4	Output Circuit Pin 4, 5 and 6	22
2.2.5	Input Circuit Pin 3, 7, 8 and 9	22
2.2.6	Output Circuit, Temperature Measurement Pin 10	22
2.2.7	Signal Connection	23
2.3	Output Signals	24
2.3.1	Setting the Behaviour of the Output Signals	24
2.3.2	Overview of Output Signal Settings	24
2.3.3	Signal Diagram (Bi-directional Mode)	25
2.4	Signal Diagram (Mono-directional Mode).....	25
2.5	Pairing the Touch Probe ("Pairing Mode")	26

2.6	Automatic Frequency Assignment for Data Transmission	26
2.7	Activation/Deactivation of the Measuring System	27
2.7.1	Bi-directional Mode	27
2.7.2	Mono-directional Mode	29
2.8	Temperature Measurement	30
2.9	Optical Indicators	31
2.9.1	Indicators for Dual Probe	32
2.9.2	Indicators for Single Probe	32
2.9.3	Transmission Power Indicator	33
2.9.4	Status-LED Error Outputs	33

1 Description



1.1 General

1.1.1 Preface

The instructions and safety instructions in this manual have to be strictly observed to guarantee a safe and reliable function of the receiver and to avoid personal and material damage. The meaning of the symbols related to the safety instructions is described in the table below:

 CAUTION	CAUTION indicates a hazardous situation that, if not avoided, could result in injury.
NOTICE	NOTICE indicates important information that, if not observed, could lead to property damage/malfunctions.
INFORMATION	INFORMATION indicates important information or helpful advices for the work with the described device.

1.1.2 Safety Instructions

 CAUTION	
Risk of injuries due to electric shock!	
When connecting the radio-wave receiver to the control, there is a danger of electric shock. Incorrect connection may result in unsafe usage of the radio-wave receiver.	
<ul style="list-style-type: none"> • Connection must only be carried out if the machine is switched to a completely de-energized state and only by especially trained and qualified personnel. 	
 CAUTION	
Risk of injuries due to moving machine parts or defect compressed air lines!	
When connecting compressed air lines there is a risk of injuries/eye injuries due to defect compressed air lines and uncontrolled moving machine parts.	
<ul style="list-style-type: none"> • Installation of the radio-wave receiver must only be carried out if the machine is switched to a completely de-energized and de-pressurized state. • Installation must only be carried out by appropriately trained and qualified personnel. • The radio-wave receiver may only be operated with the protective equipment (protective door) closed. Disabling the guards is strictly forbidden. 	
NOTICE	
Risk of material damage caused by third-party parts!	
<ul style="list-style-type: none"> • Only use the original spare parts listed in these operating instructions to perform maintenance and repairs. 	
INFORMATION	
The information given in this manual can be changed by the manufacturer at any time. Thus the user is responsible to regularly inquire about updated information.	

1.1.3 Validity

This document is valid for the hardware available at the creation date of this document. The manufacturer reserves the right to make technical modifications.

The latest version of these operating instructions can be downloaded at www.mh-inprocess.com under Downloads.

1.2 Purpose

The radio-wave receiver RWR95.51 is used for reception of the measuring signals from the touch probe system RWP20.50-G.

1.3 Declarations and Approvals

1.3.1 Europe (EC Declaration of Conformity)

The EU Declaration of Conformity can be found at the end of these operating instructions. If required, a copy of the signed original declaration of conformity may be requested from the address given on the back cover.

1.3.2 USA (FCC Declaration)

This device complies with Part 15 of the FCC. Operation is subject to the following two conditions:

This device may not cause harmful interference, and

This device must accept any interference received, including interference that may cause undesired operation.

This device has been tested and found to comply with the limits for a Class A digital device, pursuant to Part 15 of the FCC Rules. These limits are designed to provide reasonable protection against harmful interference when the device is operated in a commercial environment. This device generates, uses, and can radiate radio frequency energy and, if not installed and used in accordance with the instruction manual, may cause harmful interference to radio communications. Operation of this device in a residential area is likely to cause harmful interference in which case the user will be required to correct the interference at his own expense.

The radiated output power of the device is far below the FCC radio frequency exposure limits. Nevertheless, the device shall be used in such a manner that the potential for human contact during normal operation is minimized.

Changes or modifications not expressly approved by m&h Inprocess Messtechnik GmbH may void the FCC/RSS authorization to operate this equipment.

FCC ID: MFFRWR9551G1

1.3.3 Canada (IC /RSS Declaration)

English:

This device complies with Industry Canada licence-exempt RSS standard(s).

Operation is subject to the following two conditions:

This device may not cause harmful interference, and

This device must accept any interference received, including interference that may cause undesired operation.

Français:

Le présent appareil est conforme aux CNR d'Industrie Canada applicables aux appareils radio exempts de licence. L'exploitation est autorisée aux deux conditions suivantes:

l'appareil ne doit pas produire de brouillage, et

l'appareil doit accepter tout brouillage radioélectrique subi, même si le brouillage est susceptible d'en compromettre le fonctionnement.

IC: 5782A-RWR9551G1

1.3.4 China

This device has an RTA certificate (Radio Transmission Equipment Type Approval Certificate) issued by the SRRC (State Radio Regulatory Committee) for use in China.

CMIT ID:2019XXYYYY

1.3.5 Japan

This device has a certificate issued by the Japanese MIC (Ministry of Internal Affairs and Communications) for use in Japan. This certification complies with the Japanese Radio Law:

  202-LSH045

1.4 System Components

<p>m&h Radio-wave Touch Probe RWP20.50-G- PP/MY/TP/UTP</p> 	Single Probe		Dual Probe	Cable outlet axial
	RWR95.51-A-SP			
	RWR95.51-R-SP	RWR95.51-R-SP-PT	RWR95.51-R-DP	Cable outlet radial

Fig. 1 System Components

1.5 Technical Data

Transmission frequency	2400-2483.5 MHz (2.4 GHz)
Transmission/reception range	Up to 18 m
Power supply	12 - 30 VDC, max. 400 mA* (* depending on the output load and the operating condition)
Weight	RWR95.51-A = 1150 g (with cable)
	RWR95.51-R-SP = 1150 g (with cable)
	RWR95.51-R-SP-PT = 1330 g (with cable and protection tube)
	RWR95.51-R-DP = 1200 g (with cables)
Temperature range	Operation: 10° - 50°C Storage: 5° - 70°C
Material	Stainless steel
Sealing	IP68: EN60529 IEC529/DIN40050
Installation(TD)	4x Cap head screws M4
Connecting cable	RWR95.51-A-SP = 0.5 m with plug
	RWR95.51-R-SP = 0.5 m with plug
	RWR95.51-R-SP-PT = 2 m with plug
	RWR95.51-R-DP = 0.5 m with plug

1.6 Dimensions

1.6.1 Dimensions RWR95.51-R-SP



Fig. 2 Dimensions RWR95.51-R-SP (cable outlet radial)

1.6.2 Dimensions RWR95.51-R-SP-PT



Fig. 3 Dimensions RWR95.51-R-SP-PT (cable outlet radial)

1.6.3 Dimensions RWR95.51-R-DP



Fig. 4 Dimensions RWR95.51-R-DP (cable outlet radial)

1.6.4 Dimensions RWR95.51-A-SP

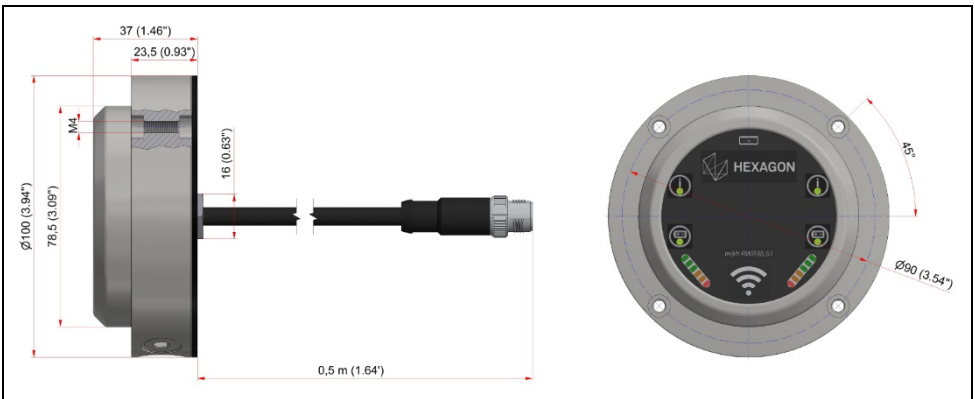

Fig. 5 Dimensions RWR95.51-A-SP (cable outlet axial)

1.7 Transmission and Reception Area

INFORMATION

The transmission/reception ranges shown below only apply under optimum operating conditions. For a secure signal transmission, measurement system and receiver must be located in the transmission area of the other device. The range for a secure signal transmission is up to 18 m.

It is recommended that the receiver is arranged so that the measurement system is within an angle of -30° to 30° relative to the receiver (see Fig. 6).

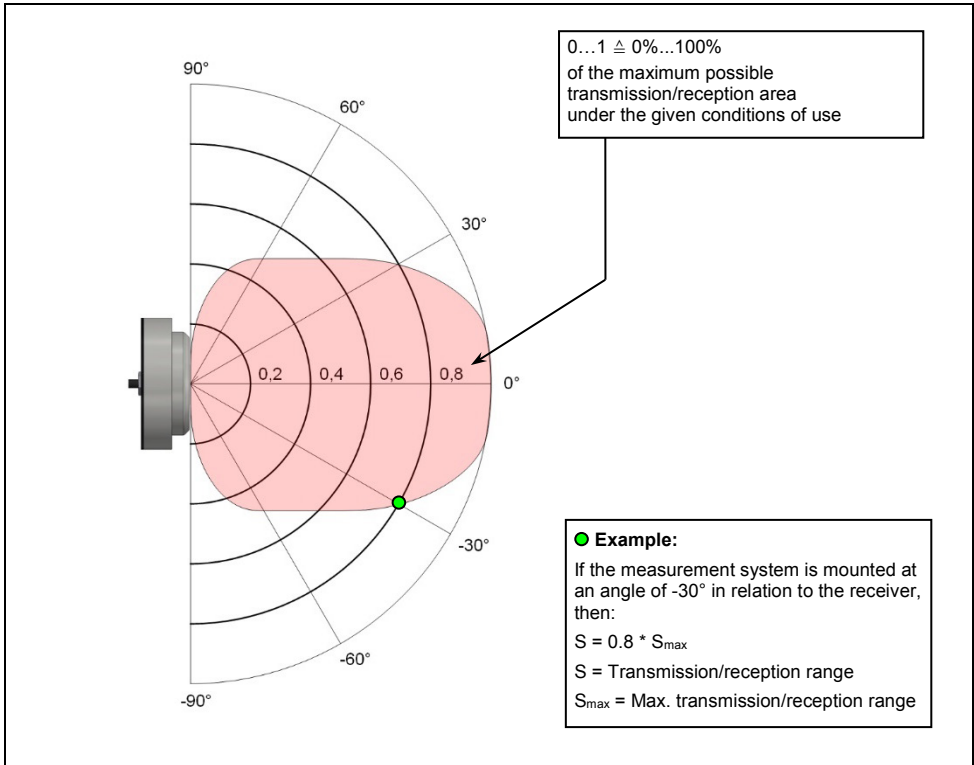











Fig. 6 Transmission and reception area (emission behaviour of antenna)



1.8 Delivery Contents, Accessories and Spares

1.8.1 Delivery Contents









Order Number	Description
95.51-RWR-A-SP	Radio-wave Receiver RWR95.51-A-SP (axial, single probe) with connecting cable (0.5 m)
95.51-RWR-R-SP	Radio-wave Receiver RWR95.51-R-SP (radial, single probe) with connecting cable (0.5 m)
95.51-RWR-R-SP-PT	Radio-wave Receiver RWR95.51-R-SP-PT (radial, single probe) with connecting cable (2 m) and protection tube (1 m)
95.51-RWR-R-DP	Radio-wave Receiver RWR95.51-R-DP (radial, dual probe) with connecting cable (0.5 m)
	Mounting parts (all versions): 4x Cap head screw DIN EN ISO 4762, M4x25 (5191) 1x Gasket (Viton) (6204) 4x Spring washer DIN128 (2012) 4x Nut DIN EN 24032, M4 (0899)
	Additional mounting parts (only RWR95.51-R-SP-PT): 1x Threaded cable gland M25x1.5 (6282) 1x Nut M25x1.5 (6283)

1.8.2 Accessories

Order Number	Description	Illustration
91.10-SI-UN	Connecting cable (L=2 m/6.6') with plug and wires for Siemens control	
91.10-FA-UN 91.10-FA-UN-15	Connecting cable (L=6 m/19.7' or L=15 m/49.2') with plug and wires for Fanuc High Speed Skip	
91.40-ST2-X12	Connecting cable (L=2 m/6.6') with plug and wires for Heidenhain (X12)	
35.40-ST2-X13	Connecting cable (L=2 m/6.6') with plug and wires for Heidenhain (X13)	
91.40-ST2-X112	Connecting cable (L=2 m/6.6') with plug and wires for Heidenhain iTNC 530 HSCI/TNC620 (X112)	
91.50-ST2-X112-DUO	Connecting cable (L=2 m/6.6') with plug and wires for Heidenhain iTNC 530 HSCI/TNC620 (X112)	
35.40-ST2-X113	Connecting cable (L=2 m/6.6') with plug and wires for Heidenhain iTNC 530 HSCI/TNC620 (X113)	
91.10-SE-UN	Connecting cable (L=2 m/6.6') with plug and wires for Selca control	
91.10-MI-UN	Connecting cable (L=2 m/6.6') with plug and wires for Mitsubishi control	

Order Number	Description	Illustration
95.51-ST5	Connecting cable (L=5 m/16.4') with plug and wires	
95.51-ST10	Connecting cable (L=10 m/32.8') with plug and wires	
95.51-ST15	Connecting cable (L=15 m/49.2') with plug and wires	
95.51-ST30	Connecting cable (L=30 m/98.4') with plug and wires	
4069	Signal converter	

1.8.3 Spares

Order Number	Description	Illustration
5191	Cap head screw DIN EN ISO 4762, M4x25	
3826	Cap head screw DIN EN ISO 4762, M5x12	
2012	Spring washer DIN128	
0899	Nut DIN EN 24032, M4	
6204	Gasket (Viton)	
6282	Threaded cable gland M25x1.5	
6283	Nut M25x1.5	
95.51-M	Mounting bracket with mounting parts: 2x Cap head screw DIN912 M4x25 (5191) 2x Cap head screw DIN912 M5x12 (3826) 2x Nut DIN EN 24 032 M4 (5286) 2x Spring washer DIN128 (2012)	

2 Operation

2.1 Mounting

2.1.1 General Instructions for Mounting

NOTICE

Risk of transmission faults!

- Never mount the receiver in the vicinity of electrical components.
- Mount the receiver as close as possible to the touch probe.
- Preferably mount the receiver isolated from the machine for optimum reception.

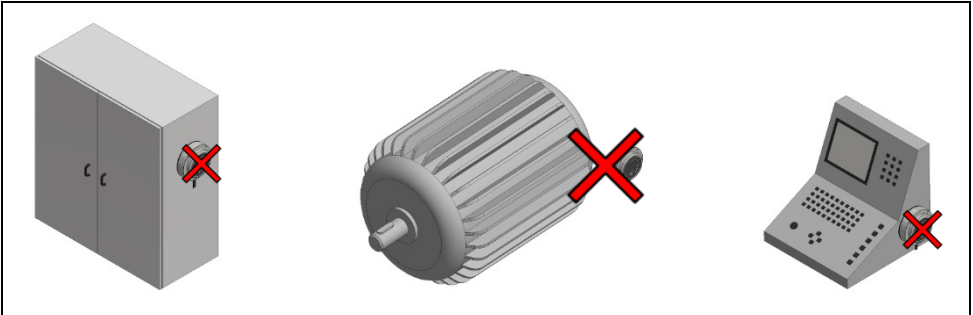

Fig. 7 Mounting Instructions

2.1.2 Mounting RWR95.51-R-SP-PT

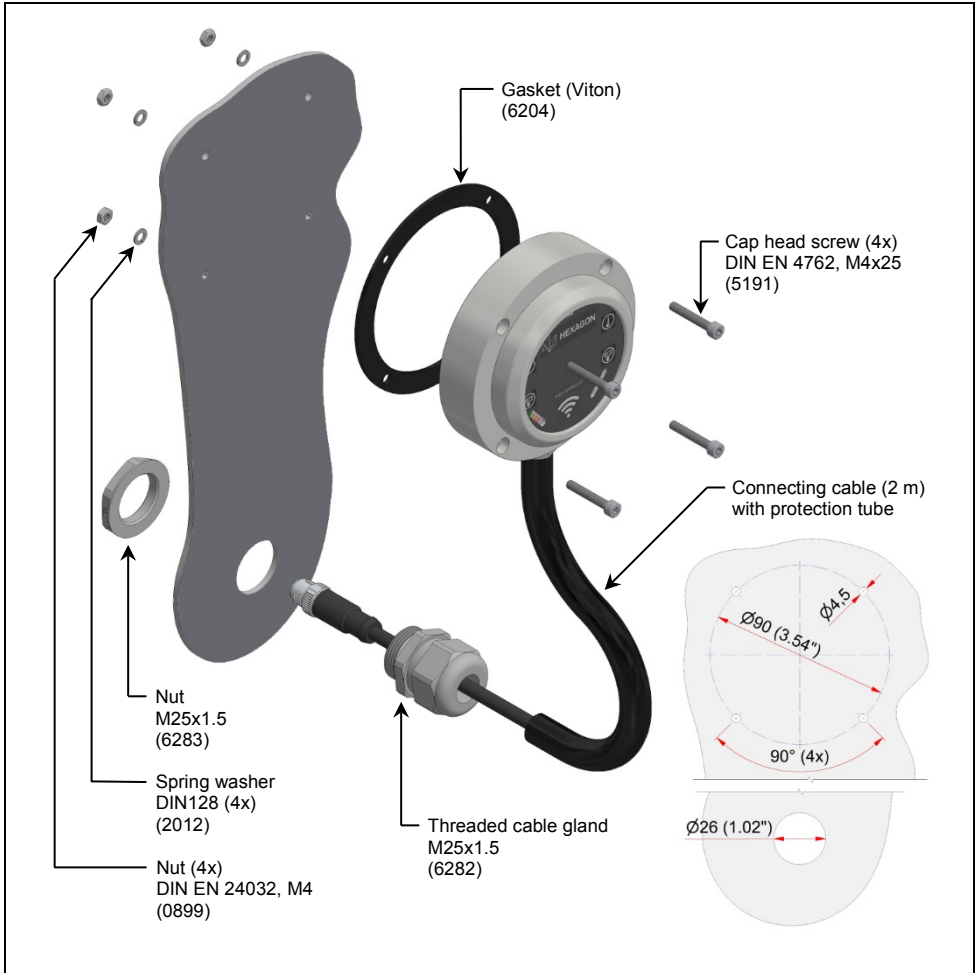

Fig. 8 Mounting RWR95.51-R-SP-PT

2.1.3 Mounting RWR95.51-R-SP/DP with Mounting Bracket (machine wall, internal)

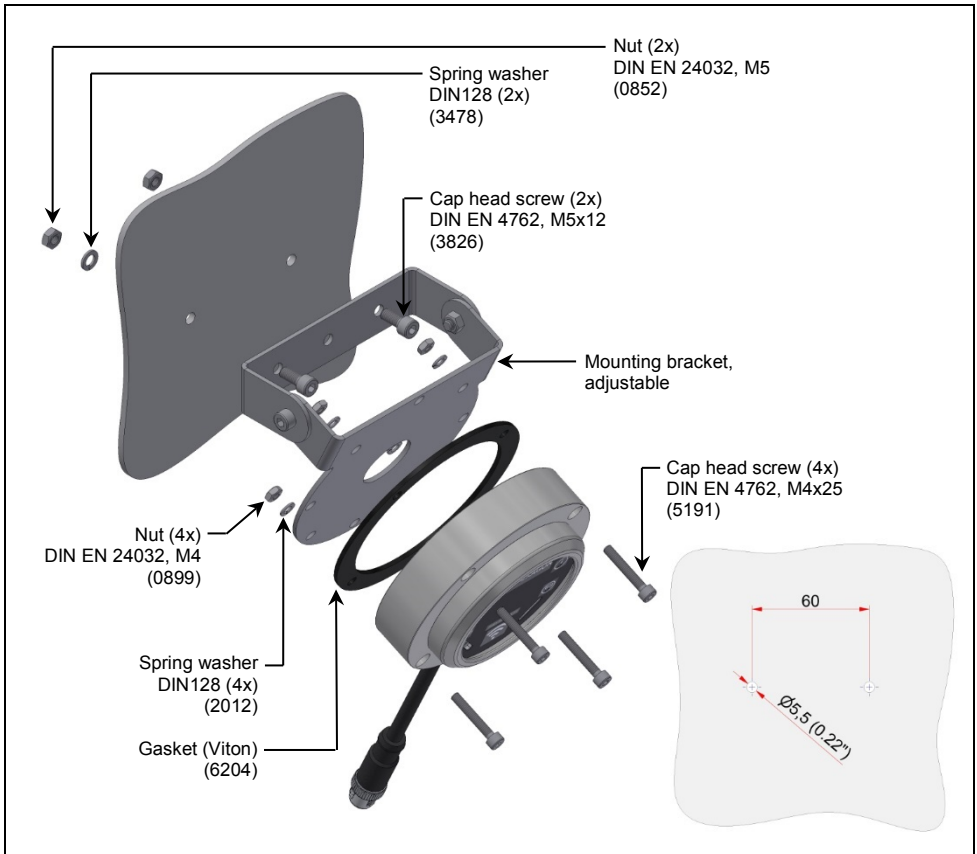

Fig. 9 Mounting RWR95.51-R-SP/DP with Mounting Bracket

2.1.4 Mounting RWR95.51-A-SP, RWR95.51-R-SP/DP (machine wall, internal)

INFORMATION

The central bore for the cable entry (see Fig. 10) is not required when mounting RWR95.51.R-SP/DP inside the machine.

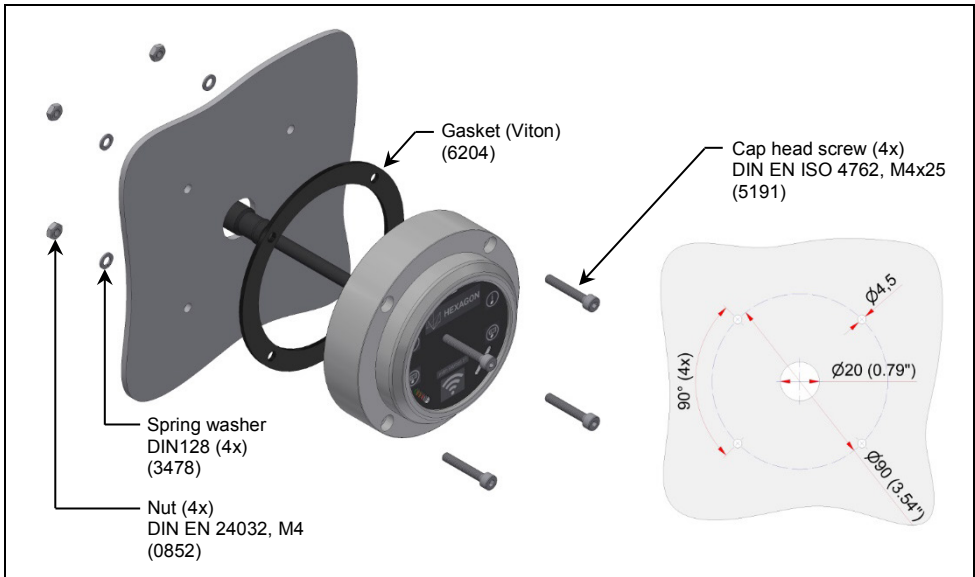

Fig. 10 Mounting RWR95.51-A-SP

2.1.5 Mounting RWR95.51-A-SP, RWR95.51-R-SP/DP (machine wall, internal)

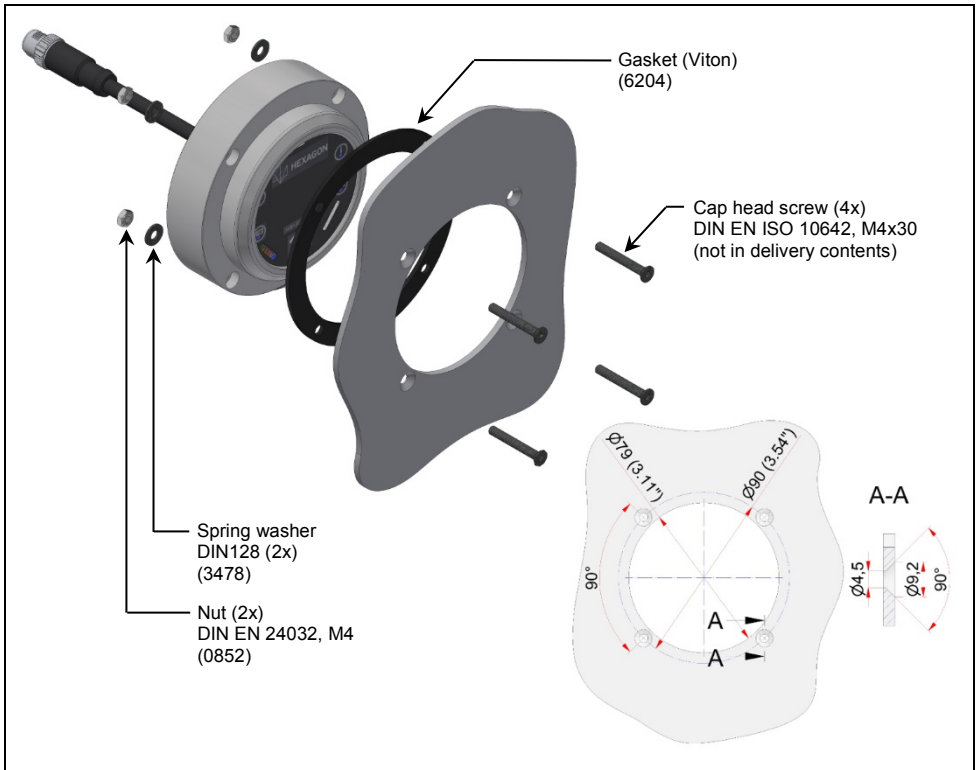

Fig. 11 Mounting RWR95.51-A-SP

2.2 Connection

INFORMATION

Wiring diagrams for specific controls and measurement-system combinations are available upon request.

NOTICE

Risk of material damage!

- First set the output signals (refer to chapter 2.3.1), then connect pins 4, 5 and 6.

2.2.1 Electrical connection Single Probe versions



Pin	Description
1	GND 0 V*
2	12-30 V*
3	ON/OFF (Bidi) / GND 0 V (Mono)
4	Probe (max. 40 mA)
5	READY (max. 40 mA)
6	LOW BATTERY (max. 40 mA)
7	Activation code Bit1 / Serial IN
8	Activation code Bit2 / Serial CLOCK
9	Activation code Bit3
10	Analog output / Serial OUT
11	not assigned
12	Signal Connection

Input (signal from machine control)
 Output (signal to machine control)

*The signals can be switched to Pin 1/2. The receiver can be operated with both polarities.

Fig. 12 Electrical connection Single Probe versions

2.2.2 Electrical connection Dual Probe version



Pin	Description
Channel 1	
1	GND 0 V*
2	12-30 V*
3	Channel 1 ON/OFF (Bidi) / GND 0 V (Mono)
4	Probe Channel 1 (max. 40 mA)
5	READY Channel 1 (max. 40 mA)
6	LOW BATTERY Channel 1 (max. 40 mA)
7	Activation code Channel 1 Bit1 / Serial IN
8	Activation code Channel 1 Bit2 / Serial CLOCK
9	Activation code Channel 1 Bit3
10	Analog output / Serial OUT
11	not assigned
12	Signal Connection
Channel 2	
1	not assigned
2	not assigned
3	Channel 2 ON/OFF (Bidi) / GND 0 V (Mono)
4	Probe Channel 2 (max. 40 mA)
5	READY Channel 2 (max. 40 mA)
6	LOW BATTERY Channel 2 (max. 40 mA)
7	Activation code Channel 2 Bit1 / Serial IN
8	Activation code Channel 2 Bit2 / Serial CLOCK
9	Activation code Channel 2 Bit3
10	Analog output / Serial OUT
11	not assigned
12	not assigned

Input (signal from machine control)
 Output (signal to machine control)

*The signals can be switched to Pin 1/2. The receiver can be operated with both polarities.

Fig. 13 Electrical connection Dual Probe versions

2.2.3 Overview of wire colours when using 95.51-STXX



Pin	Description	Colour
1	GND 0 V*	brown
2	12-30 V*	blue
3	M code ON/OFF (Bidi) / GND 0 V (Mono)	white
4	Probe (max. 40 mA)	green
5	READY (max. 40 mA)	pink
6	LOW BATTERY (max. 40 mA)	yellow
7	Activation code Bit1 / Serial IN	black
8	Activation code Bit2 / Serial CLOCK	grey
9	Activation code Bit3	red
10	Analog output / Serial OUT	purple
11	not assigned	grey-pink
12	Signal Connection	red-blue

*The signals can be switched to Pin 1/2. The receiver can be operated with both polarities.

Fig. 14 Electrical connection Single Probe versions

2.2.4 Output Circuit Pin 4, 5 and 6

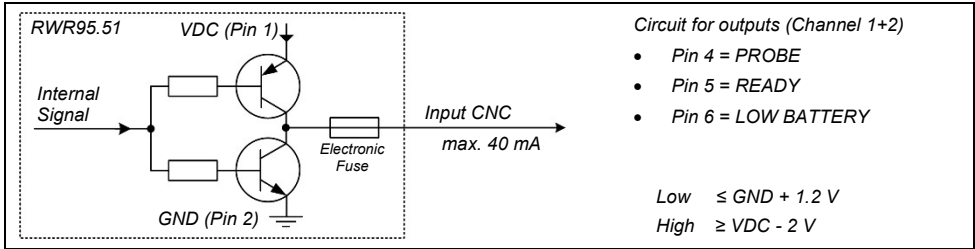

Fig. 15 Output Circuit Pin 4, 5 and 6

2.2.5 Input Circuit Pin 3, 7, 8 and 9

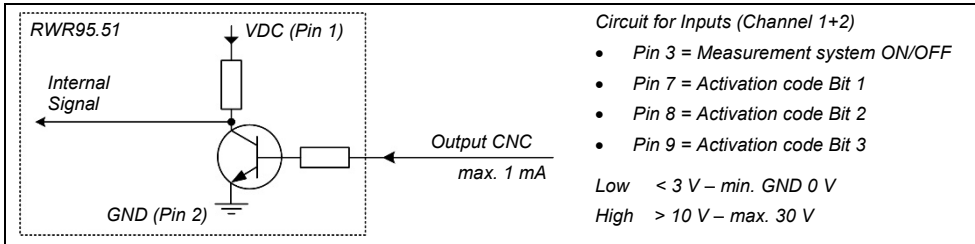

Fig. 16 Input Circuit Pin 3, 7, 8 and 9

2.2.6 Output Circuit, Temperature Measurement Pin 10

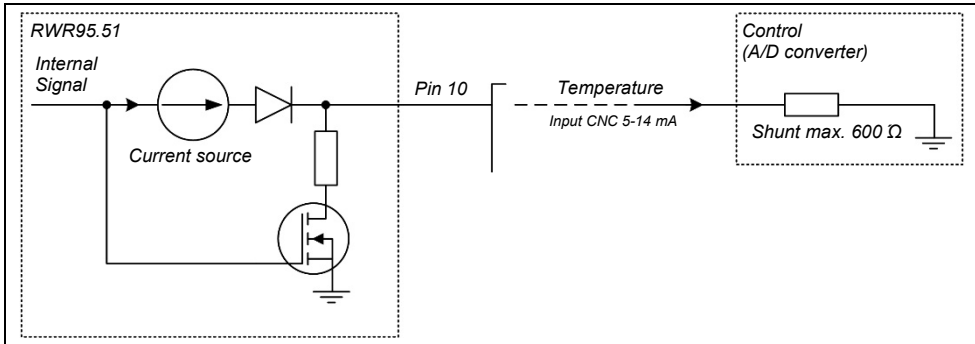

Fig. 17 Output Circuit, Temperature Measurement Pin 10

2.2.7 Signal Connection

INFORMATION

Temperature measurement is not possible with signal connection!

INFORMATION

Signal connection is recommended, if the machine control cannot check READY.
The signal connection is scanned once when the receiver restarts.

Signal connection is active, if a voltage >10 VDC (HIGH) is applied to Pin 12 (for version RWR95.51-DP, use Pin 12 from channel 1):

- ERROR causes PROBE

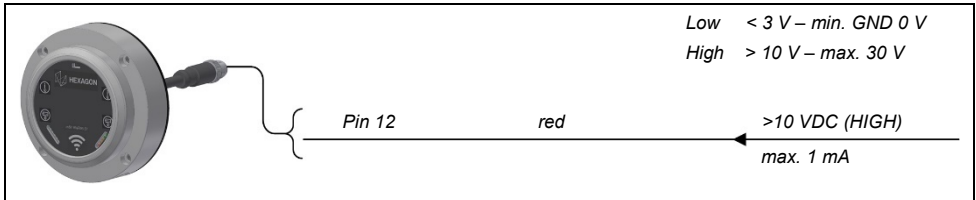

Fig. 18 Signal Connection

2.3 Output Signals

2.3.1 Setting the Behaviour of the Output Signals

The behaviour of the output signals is set using a rotary coding switch on the rear of the device. The setting only takes effect after a restart of the receiver.

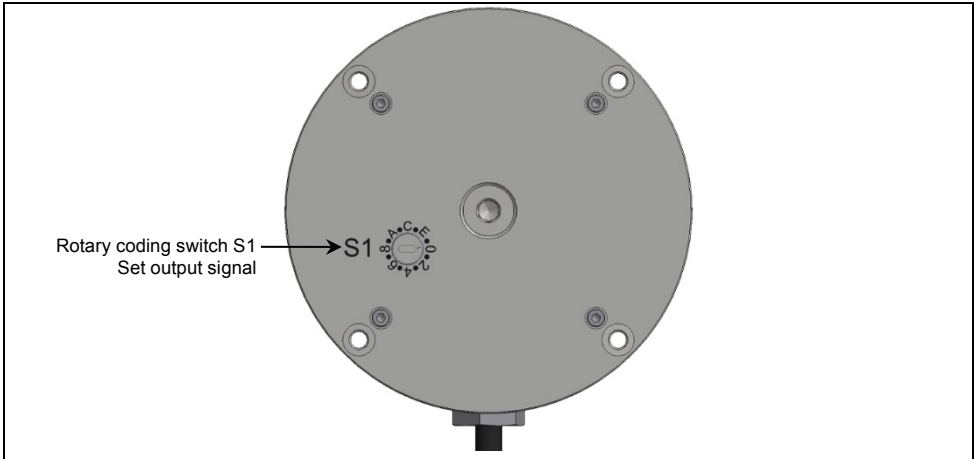



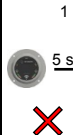











Fig. 19 Setting of output signal with the rotary coding switch

2.3.2 Overview of Output Signal Settings

Configuration	PROBE	ERROR	LOW BATTERY	Control
All output signals Push-Pull: LOW ≤ GND+1,2 V; HIGH ≥ VDC-2 V				
0*)	HIGH→LOW	HIGH→LOW	HIGH→LOW	Heidenhain/Siemens
1	HIGH→LOW	HIGH→LOW	LOW→HIGH	Fanuc Ordinary Skip / Siemens
2	HIGH→LOW	LOW→HIGH	LOW→HIGH	Fanuc Ordinary Skip / Siemens
3	LOW→HIGH	LOW→HIGH	LOW→HIGH	Fanuc Ordinary Skip / Siemens
4	LOW→HIGH	LOW→HIGH	HIGH→LOW	Fanuc Ordinary Skip / Siemens
5	LOW→HIGH	HIGH→LOW	HIGH→LOW	Fanuc Ordinary Skip / Siemens
6	LOW→HIGH	HIGH→LOW	LOW→HIGH	Fanuc Ordinary Skip / Siemens
7	HIGH→LOW	LOW→HIGH	HIGH→LOW	Fanuc Ordinary Skip / Siemens
	HIGH = 3.9 V – 5.4 V			
8	LOW→HIGH	HIGH→LOW	HIGH→LOW	Fanuc High Speed Skip
9	HIGH→LOW	HIGH→LOW	LOW→HIGH	Fanuc High Speed Skip
A	HIGH→LOW	LOW→HIGH	LOW→HIGH	Fanuc High Speed Skip
B	LOW→HIGH	LOW→HIGH	LOW→HIGH	Fanuc High Speed Skip
C	LOW→HIGH	LOW→HIGH	HIGH→LOW	Fanuc High Speed Skip
D	HIGH→LOW	HIGH→LOW	HIGH→LOW	Fanuc High Speed Skip
E	LOW→HIGH	HIGH→LOW	LOW→HIGH	Fanuc High Speed Skip
F	Reserved for Automatic Configuration (further information from service.mh@hexagon.com).			
*) Setting for standard delivery				









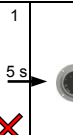

2.3.3 Signal Diagram (Bi-directional Mode)

Example of output signal "0" (Heidenhain/Siemens)

										
Received Signal	RWR95.51 OFF	RWR95.51 ON	Switching ON procedure	Touch probe ON	Touch probe deflected	ERROR during PROBE	LOW BATTERY	ERROR	Switching OFF procedure	Touch probe OFF
PROBE	---	HIGH	HIGH	HIGH	LOW	HIGH	HIGH	HIGH	HIGH	HIGH
READY	---	LOW	LOW	HIGH	HIGH	LOW	HIGH	LOW	LOW	LOW
LOW BATTERY	---	HIGH	HIGH	HIGH	HIGH	HIGH	LOW	HIGH	HIGH	HIGH
Pin 3 Measurement system ON	HIGH	LOW	HIGH	HIGH	HIGH	HIGH	HIGH	HIGH	LOW	LOW
		red	green flashing	green	orange	red	green	red	red	red
							red			

2.4 Signal Diagram (Mono-directional Mode)

Example of output signal "0" (Heidenhain/Siemens)

								
Received Signal	RWR95.51 OFF	RWR95.51 ON	Touch probe in Spindle (ON)	Touch probe deflected	ERROR during PROBE	LOW BATTERY	ERROR	Touch probe from Spindle (OFF)
PROBE	---	HIGH	HIGH	LOW	HIGH	HIGH	HIGH	HIGH
READY	---	LOW	HIGH	HIGH	LOW	HIGH	LOW	LOW
LOW BATTERY	---	HIGH	HIGH	HIGH	HIGH	LOW	HIGH	HIGH
		red	green	orange	red	green	red	red
						red		

2.5 Pairing the Touch Probe ("Pairing Mode")

Each RWR95.51 receiver is able to control the addresses of 8 **bidirectional** touch probes (Activation code A-H). These touch probes are assigned in "Pairing Mode" either via the integrated **IRDA interface** or by **entering the serial number of the receiver** on the touch probe. The address of the receiver is uniquely assigned to the touch probe and the address of the touch probe to the receiver.

Should another touch probe be assigned the same activation configuration (A-H) as a touch probe already assigned at a later time, then the address of the touch probe first assigned is deleted in the receiver and the address of the new touch probe is saved.

If a touch probe that has already been paired is paired with another set activation code, the previous pairing will be deleted. This means that it is not possible to pair a touch probe more than once using different activation codes. Pairing mode is started by the probe and the precise procedure for assignment is described in the operating instructions for the touch probe.

With mono-directional activation, the address of the touch probe is also assigned to the receiver in "pairing mode". Any number of mono-directional touch probes can be operated by only one receiver. They only have to be paired once with their first use and are automatically detected by the receiver with subsequent use.

2.6 Automatic Frequency Assignment for Data Transmission

Blocking of Faulty Frequencies:

Providing the receiver is in "ERROR" status (no active connection between the touch probe/receiver), the receiver checks the environment for radio interference and evaluates the available frequencies in terms of their suitability for communication with the touch probe (signal quality). This enables all radio interference to be detected within a short time. Should a touch probe now be activated bidirectionally or should a mono-directionally activated touch probe issue a communication request, then the receiver assigns it to a transmission frequency with as small an interference range as possible.

Release of Frequencies:

If it is in "ERROR" status (no active connection between the touch probe/receiver), the receiver continues to always check the environment and constantly evaluates the frequencies. Therefore with new or additional communication requests, frequencies previously classified as poor can also be assigned, as the environmental situation (interference) has now been able to be improved.

2.7 Activation/Deactivation of the Measuring System

2.7.1 Bi-directional Mode

INFORMATION

In "ERROR" mode, the receiver scans the entire frequency range available to it for interference and internally evaluates the available frequency bands for their quality.
 If a touch probe is activated with a radio-wave signal, then the information is simultaneously transmitted with the activation signal about which frequency band communication is to be made (best quality).
 The transmission is a semi-duplex transmission, i.e. the signal transmission takes place alternately in both directions.

1. Switching ON the probe:
 - 1.1 Load probe.
 - 1.2 Machine control transmits switch ON signal and activation code to receiver.
 - 1.3 Receiver switches touch probe on by radio-wave signal and transmits the optimum frequency band for further communication.
 - 1.4 Touch probe transmits "READY" signals to receiver.
 - 1.5 Receiver transmits "READY" signal to machine control.
 - 1.6 Probe ready to work.
2. Switching OFF the touch probe:
 - 2.1 Machine control sends switch-off signal to receiver.
 - 2.2 The touch probe automatically switches to Standby mode as soon as no transmission confirmation from the receiver is registered.

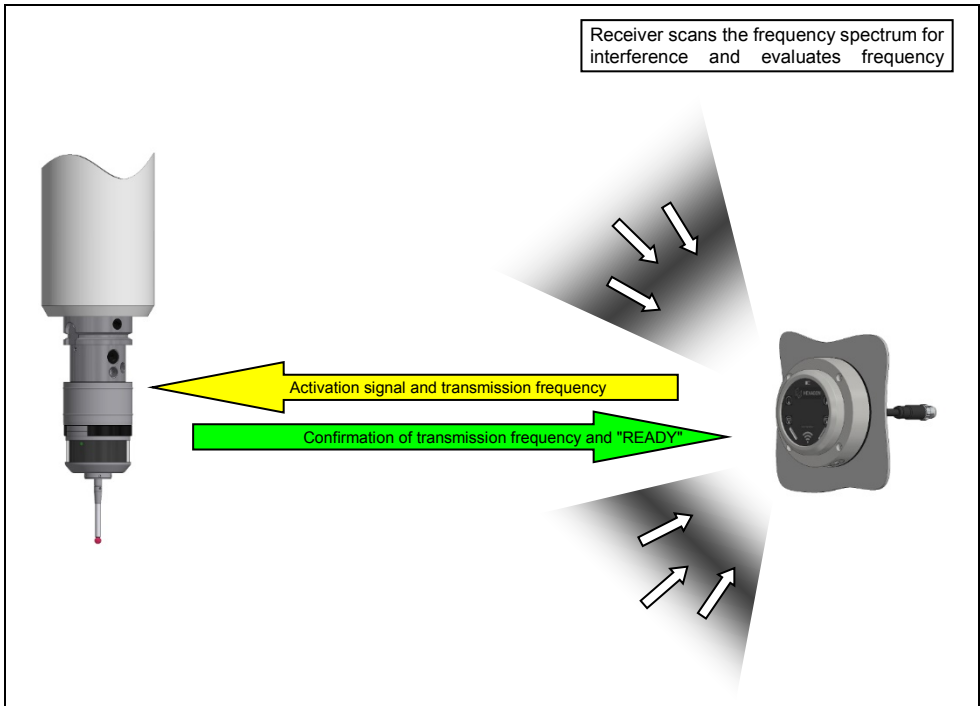

Fig. 20 Measurement system activation in bi-directional mode

The touch probe RWP20.50-G can be activated and deactivated by the radio-wave receiver RWR95.51. Once the M code has been set, the touch probe will be activated in < 1 s and deactivated again < 1 s after reset. The subsequent table shows the signal curves during probe activation in bi-directional mode:

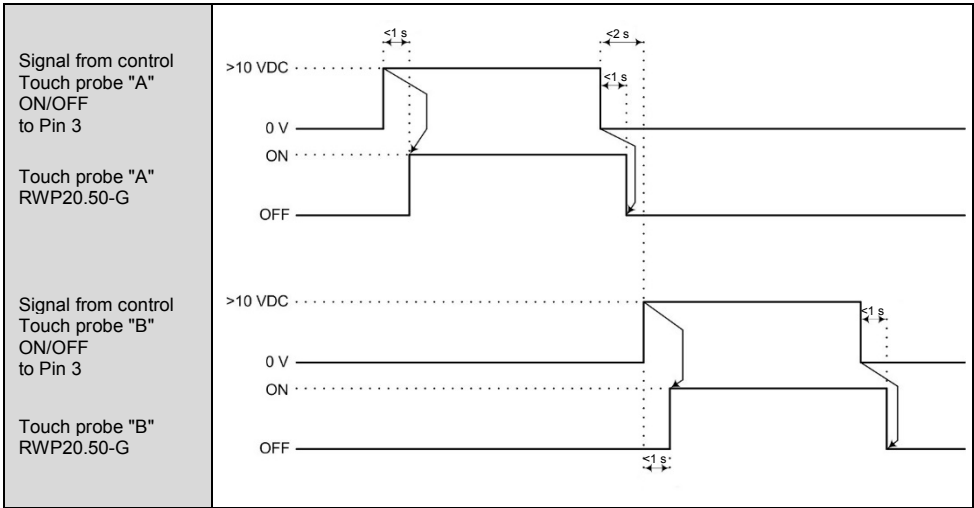

Fig. 21 Signal curves during touch probe/tool setter activation in bi-directional mode

Set the activation code of the touch probe on the receiver:

In order to establish a connection between the RWR95.51 radio-wave receiver and an RWP20.50-G radio-wave touch probe, the receiver must be set to the activation code of the touch probe (A-H). To do this, the connection pins 7, 8 and 9 of the receiver must be wired according to the following table:

Activation code of touch probe								
	A	B	C	D	E	F	G	H
Pin7 (Bit 1)	LOW	HIGH	LOW	HIGH	LOW	HIGH	LOW	HIGH
Pin 8 (Bit 2)	LOW	LOW	HIGH	HIGH	LOW	LOW	HIGH	HIGH
Pin 9 (Bit 3)	LOW	LOW	LOW	LOW	HIGH	HIGH	HIGH	HIGH

INFORMATION

The activation code set with the connection pins 7,8 and 9 does not take effect, until the touch probe is activated via connection pin 3. The activation code **must** therefore be set before activating the touch probe!

The exact procedure for setting the activation code of the touch probe or for checking the existing setting is described in the RWP20.50-G operating Instructions.

2.7.2 Mono-directional Mode

INFORMATION

Mechanical self activation of the probe.

1. Switching ON the probe:
 - 1.1 Load probe into spindle.
 - 1.2 Probe switches ON by mechanical ON-OFF method:
 - AZ → Pullforce at SK-pullstud
 - ME → Switch ON mechanism in HSK
 - WS → Cooling water supply or spindle air blast
 (Description of mechanical switch ON methods in the respective operating instructions)
 - 1.3 Probe transmits Wake-Up signal to receiver.
 - 1.4 Receiver transmits transmission frequency to be used to probe.
 - 1.5 Probe sends confirmation of transmission frequency and "READY" signal to receiver.
 - 1.6 Receiver passes electrical READY signal to machine control.
 - 1.7 Probe ready to work.
2. Switching OFF the touch probe:
 - 2.1 Remove the probe from the spindle to switch off the probe.

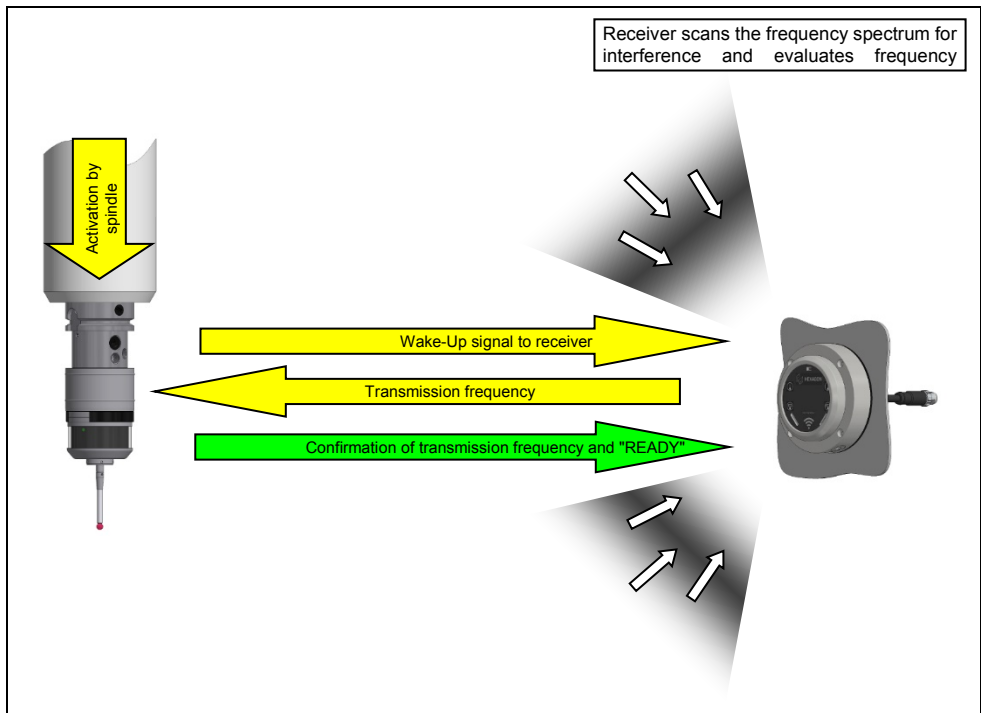

Fig. 22 Activation of the measurement system in mono-directional mode

2.8 Temperature Measurement

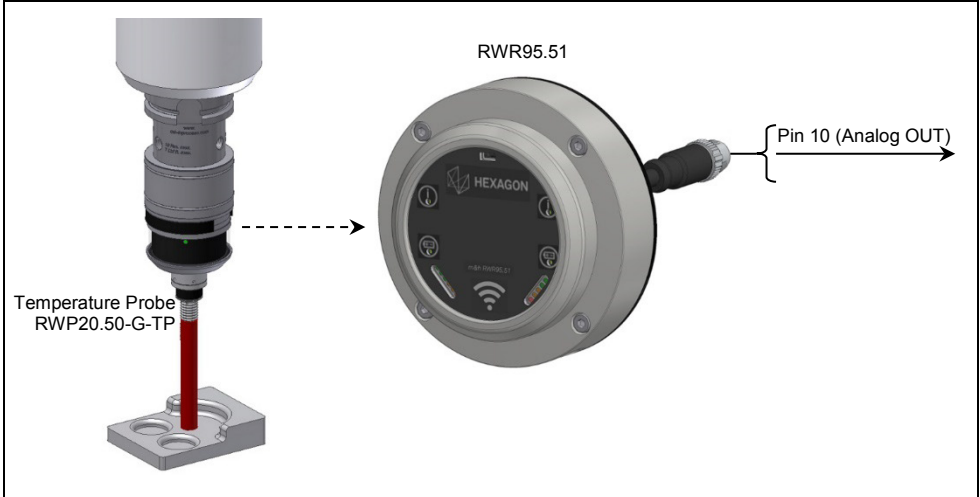

Fig. 23 Temperature Measurement

Measuring Range	5 - 50°C (5-14 mA)
	41 - 122°F (5-14 mA)
Resolution	$\Delta 0.1^\circ\text{C} = 20 \mu\text{A}$
	$\Delta 0.182^\circ\text{F} = 20 \mu\text{A}$

Temperature Calculation:
 $(x \text{ mA} * 5^\circ\text{C}/\text{mA}) - 20^\circ\text{C} = \text{Temperature in } ^\circ\text{C}$
 $(x \text{ mA} * 9^\circ\text{F}/\text{mA}) - 4^\circ\text{F} = \text{Temperature in } ^\circ\text{F}$

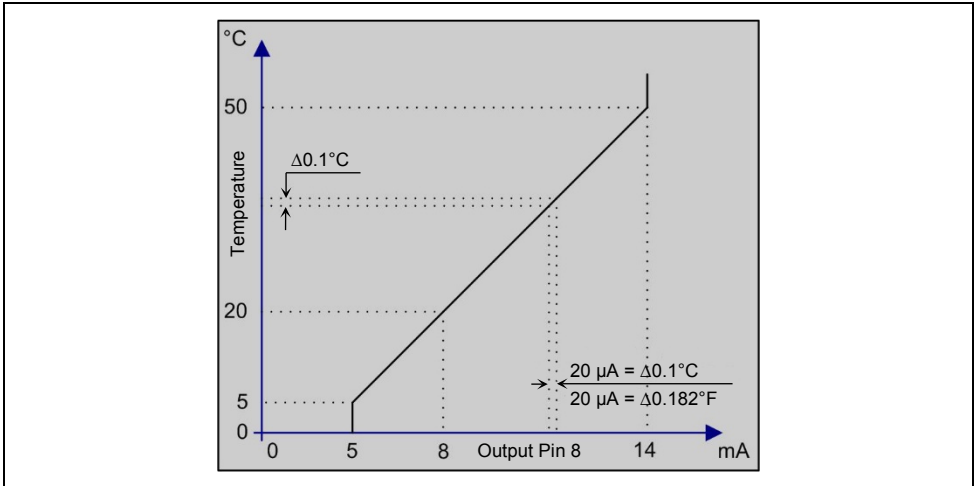

Fig. 24 Temperature Characteristic of RWR95.51

2.9 Optical Indicators

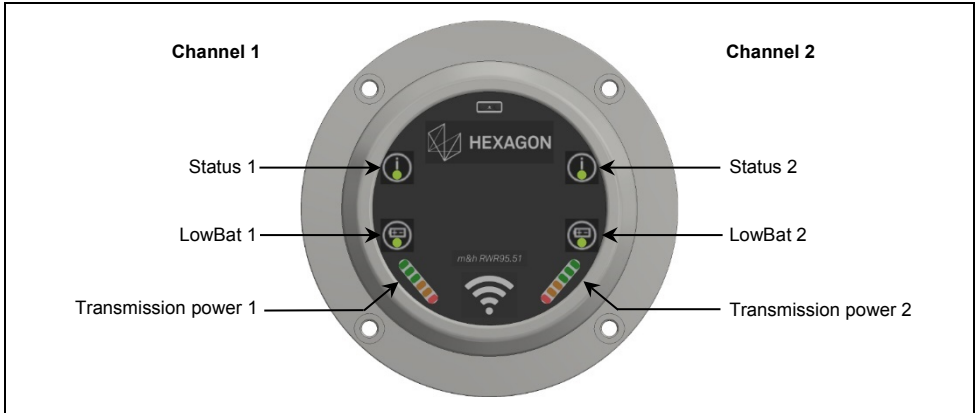













Fig. 25 LED Indicators of RWR95.51







INFORMATION

The radio-wave receiver RWR95.51 can control up to 8 touch probes. This corresponds to the activation codes "A" to "H". When operating two probes with one radio-wave receiver in "Dual Probe" mode, both receiver channels can be assigned a touch probe with any of the activation codes "A" to "H". The inputs are assigned and the activation codes are set on the touch probe.

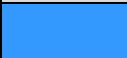
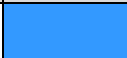

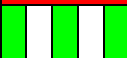
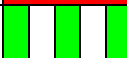
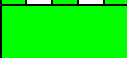
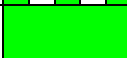

2.9.1 Indicators for Dual Probe

Status	Status 1	LowBat 1	Status 2	LowBat 2
<ul style="list-style-type: none"> Initialisation (5 s after start) 				
<ul style="list-style-type: none"> Inactive status of measurement system 1 + 2 Status: ERROR 				
<ul style="list-style-type: none"> Activation of measurement system 1 (only in bi-directional mode) 				
<ul style="list-style-type: none"> Activation of measurement system 2 (only in bi-directional mode) 				
<ul style="list-style-type: none"> Receives signals from measurement system 1 Status: "READY" 				
<ul style="list-style-type: none"> Receives signals from measurement system 2 Status: "READY" 				
<ul style="list-style-type: none"> Measurement system 1 deflected Status: PROBE 				
<ul style="list-style-type: none"> Measurement system 2 deflected Status: PROBE 				
<ul style="list-style-type: none"> LOW BATTERY measurement system 1 Status: LOW BATTERY 				
<ul style="list-style-type: none"> LOW BATTERY measurement system 2 Status: LOW BATTERY 				







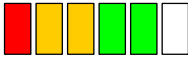
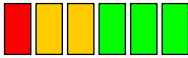

























2.9.2 Indicators for Single Probe

Status	Status 1	LowBat 1	Status 2	LowBat 2
<ul style="list-style-type: none"> Initialisation (5 s after start) 				
<ul style="list-style-type: none"> Inactive status of measurement system Status: ERROR 				
<ul style="list-style-type: none"> Activation of measurement system (only in bi-directional mode) 				
<ul style="list-style-type: none"> Receives signals from measurement system Status: "READY" 				
<ul style="list-style-type: none"> Measurement system deflected Status: PROBE 				
<ul style="list-style-type: none"> LOW BATTERY measurement system Status: LOW BATTERY 				

2.9.3 Transmission Power Indicator

Transmission/Reception Power	Indicator
<p>Poor</p>  <p>Optimum</p>	
	
	
	
	
	

2.9.4 Status-LED Error Outputs

Status	Status 1	LowBat 1	Status 2	LowBat 2
<ul style="list-style-type: none"> Measurement system 1 - Short-circuit Pin 4, 5, 6 ▶ Check circuit of pin 4, 5, 6 				
<ul style="list-style-type: none"> No touch probe has been applied/paired to Channel 1 for the selected activation code 				
<ul style="list-style-type: none"> Measurement system 2 - Short-circuit Pin 4, 5, 6 ▶ Check circuit of pin 4, 5, 6 				
<ul style="list-style-type: none"> No touch probe has been applied/paired to Channel 2 for the selected activation code 				
<ul style="list-style-type: none"> Measurement system 1 - Error during first probing ▶ Repeat measurement 				
<ul style="list-style-type: none"> Measurement system 2 - Error during first probing ▶ Repeat measurement 				
<ul style="list-style-type: none"> Measurement system 1 - No temperature value ▶ Check circuit of pin 10 				
<ul style="list-style-type: none"> Measurement system 2 - No temperature value ▶ Check circuit of pin 10 				
 Status of the LED depends on the current status of the second channel				



EU-Konformitätserklärung

Die alleinige Verantwortung für die Ausstellung dieser Konformitätserklärung trägt die Firma m&h Inprocess Messtechnik GmbH.

Hersteller/Bevollmächtigter: **m&h Inprocess Messtechnik GmbH**
Am Langholz 11
88289 Waldburg
Germany

Produktbezeichnung: **Funk-Empfänger**

Modell/Typ: **RWR95.51**

Das oben genannte Produkt erfüllt die Anforderungen der folgenden einschlägigen Richtlinien/Normen:

Richtlinie / Norm	Ausgabe	Titel / Abschnitt
2011/65/EU	2011	Beschränkung der Verwendung bestimmter gefährlicher Stoffe in Elektro- und Elektronikgeräten
2014/53/EU	2014	Bereitstellung von Funkanlagen auf dem Markt
2014/30/EU	2014	Elektromagnetische Verträglichkeit
DIN EN 61326-1	2013	Elektrische Mess-, Steuer-, Regel- und Laborgeräte - EMV-Anforderungen - Teil 1
DIN EN 61326-2-2	2013	Elektrische Mess-, Steuer-, Regel- und Laborgeräte - EMV-Anforderungen - Teil 2-2
DIN EN 55011	2018	Industrielle, wissenschaftliche und medizinische Geräte - Funkstörungen - Grenzwerte und Messverfahren
DIN EN 300328	2017	Breitband-Übertragungssysteme - Datenübertragungsgeräte, die im 2,4-GHz-ISM-Band arbeiten und Breitband-Modulationstechniken verwenden
DIN EN 301489-1	2017	Elektromagnetische Verträglichkeit für Funkeinrichtungen und -dienste - Teil 1
DIN EN 301489-3	2017	Elektromagnetische Verträglichkeit für Funkeinrichtungen und -dienste - Teil 3
DIN EN 301489-17	2017	Elektromagnetische Verträglichkeit für Funkeinrichtungen und -dienste - Teil 17
DIN EN 12100	2011	Sicherheit von Maschinen - Allgemeine Gestaltungsleitsätze - Risikobeurteilung und Risikominderung



Waldburg, 31.03.2019

Ort, Datum

Wolfgang Madlener, Geschäftsführer





HEXAGON
MANUFACTURING INTELLIGENCE

Hexagon Manufacturing Intelligence helps industrial manufacturers develop the disruptive technologies of today and the life-changing products of tomorrow. As a leading metrology and manufacturing solution specialist, our expertise in sensing, thinking and acting – the collection, analysis and active use of measurement data – gives our customers the confidence to increase production speed and accelerate productivity while enhancing product quality.

Through a network of local service centres, production facilities and commercial operations across five continents, we are shaping smart change in manufacturing to build a world where quality drives productivity. For more information, visit HexagonMI.com.

Hexagon Manufacturing Intelligence is part of Hexagon (Nasdaq Stockholm: HEXA B; hexagon.com), a leading global provider of information technologies that drive quality and productivity across geospatial and industrial enterprise applications.

-  COORDINATE MEASURING MACHINES
-  3D LASER SCANNING
-  SENSORS
-  PORTABLE MEASURING ARMS
-  SERVICES
-  LASER TRACKERS & STATIONS
-  MULTISENSOR & OPTICAL SYSTEMS
-  WHITE LIGHT SCANNERS
-  METROLOGY SOFTWARE SOLUTIONS
-  CAD / CAM
-  STATISTICAL PROCESS & CONTROL
-  AUTOMATED APPLICATIONS
-  MICROMETERS, CALIPERS AND GAGES
-  DESIGN AND COSTING SOFTWARE

m&h Inprocess Messtechnik GmbH

Am Langholz 11
88289 Waldburg
Germany

Tel. +49 (0)7529 9733 0
Fax +49 (0)7529 9733 7
sales.mh@hexagon.com
www.mh-inprocess.com

m&h – Part of Hexagon Manufacturing Intelligence