

TEST REPORT FOR FCC
Class II PERMISSIVE CHANGE
On Behalf of
Amtran Technology Co., Ltd.
Bluetooth Embedded Module
Total Model No.: BCM92046MD_EMB
FCC ID: MDZSV422XVT-BT

Prepared for : Amtran Technology Co., Ltd.
17F, No.268, Lien Chen Rd., Chung Ho City,
Taipei County, Taiwan, 235 R.O.C.

Prepared by : AUDIX Technology Corporation
EMC Department
No. 53-11, Tin-Fu Tsun, Lin-Kou,
Taipei, Taiwan

Tel : (02) 2609-9301, 2609-2133
Fax: (02) 2609-9303

File Number : C1M1008245
Report Number : EM-F990924
Date of Test : Mar. 01 ~ Sep. 15, 2010
Date of Report : Sep. 16, 2010

TABLE OF CONTENTS

Description	Page
TEST REPORT CERTIFICATION	3
1. DESCRIPTION OF VERSION	4
2. GENERAL INFORMATION	5
2.1. Description of Device (EUT).....	5
2.2. Tested Supporting System Details	6
2.3. Description of Test Facility	6
2.4. Measurement Uncertainty	7
3. CONDUCTED EMISSION MEASUREMENT.....	8
4. RADIATED EMISSION MEASUREMENT	9
4.1. Test Equipment	9
4.2. Test Setup	9
4.3. Radiated Emission Limits (§15.209)	11
4.4. Operating Condition of EUT	11
4.5. Test Procedure	11
4.6. Radiated Emission Measurement Results.....	12
5. MAXIMUM PEAK OUTPUT POWER MEASUREMENT	27
5.1. Test Equipment	27
5.2. Block Diagram of Test Setup.....	27
5.3. Specification Limits (§15.247(b)-(1)).....	27
5.4. Operating Condition of EUT	27
5.5. Test Procedure follow DA00-705.....	27
5.6. Test Results.....	28
6. DEVIATION TO TEST SPECIFICATIONS	29
7. PHOTOGRAPHS	30
7.1. Photos of Radiated Measurement at Semi-Anechoic Chamber	30
7.2. Photo of Maximum Peak Output Power Measurement	32

Appendix

TEST REPORT CERTIFICATION (Class II Permissive Change)

Applicant : Amtran Technology Co., Ltd.
 EUT Description : Bluetooth Embedded Module
 FCC ID : MDZSV422XVT-BT
 (A) MODEL NO. : BCM92046MD_EMB
 (B) SERIAL NO. : N/A
 (C) POWER SUPPLY : DC 5V
 (D) TEST VOLTAGE : AC 120V, 60Hz
 (Via LCD TV or Notebook PC)

Measurement Procedure Used:

FCC RULES AND REGULATIONS PART 15 SUBPART C, Oct. 2009
 AND ANSI C63.4/2003

(FCC CFR 47 Part 15C, §15.205, §15.207, §15.209 and §15.247)

The device described above was tested by AUDIX Technology Corporation to determine the maximum emission levels emanating from the device. The maximum emission levels were compared to the FCC Part 15 subpart C limits.

The measurement results are contained in this test report and AUDIX Technology Corporation is assumed full responsibility for the accuracy and completeness of these measurements. Also, this report shows that the EUT to be technically compliant with the FCC official limits.

This report applies to above tested sample only. This report shall not be reproduced in part without written approval of AUDIX Technology Corporation.

This report is based on reports of EM-F980571, EM-F980641, EM-F990210, EM-F990320 and EM-F990341.

Date of Test: Mar. 01~ Sep. 15, 2010

Date of Report: Sep. 16, 2010

Date of Test of Original: Aug. 03 ~ 05, 2009

Date of Original: Aug. 13, 2009

Producer: 
 (Julie Hsu/Administrator)

Reviewer: 
 (Henning Chang/Supervisor)

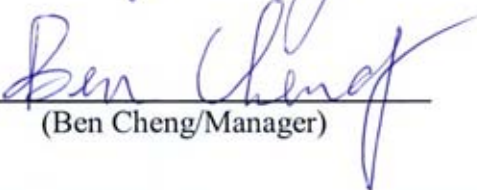
Signatory: 
 (Ben Cheng/Manager)

1. DESCRIPTION OF VERSION

Edition No.	Date of Rev.	Summary	Report No.
Rev. 0	Aug. 13, 2009	Original Report.	EM-F980571
Rev. 1	Sep. 01, 2009	<ol style="list-style-type: none"> 1. There is no hardware or electrical modification made to the applying modular transmitter itself. The changes filed under this application are adding LCD TV Model VIZIO VF552XVT collocated with Bluetooth Embedded Module, FCC ID: MDZSV422XVT-BT. 2. Supplementary test data are recorded in report of EM-F980641. 	EM-F980641
Rev. 2	Mar. 15, 2010	<ol style="list-style-type: none"> 1. The changes filed under this application are adding LCD TV Model VIZIO M550NV collocated with Bluetooth Embedded Module, FCC ID: MDZSV422XVT-BT. And the PCB's electronic circuit changes are described at appendix. 2. Supplementary test data are recorded in test report of EM-F990210. 	EM-F990210
Rev. 3	Apr. 12, 2010	<ol style="list-style-type: none"> 1. The changes filed under this application are adding LCD TV Model VIZIO XVT423SV / VIZIO XVT423SV-XX / XVT423SV collocated with Bluetooth Embedded Module, FCC ID: MDZSV422XVT-BT. And the PCB's electronic circuit changes are described at appendix. 2. Supplementary test data are recorded in test report of EM-F990320. 	EM-F990320
Rev. 4	Apr. 14, 2010	<ol style="list-style-type: none"> 1. The changes filed under this application are adding LCD TV Model VIZIO XVT323SV####, XVT323SV#### collocated with Bluetooth Embedded Module, FCC ID: MDZSV422XVT-BT. And the PCB's electronic circuit changes are described at appendix. 2. Supplementary test data are recorded in test report of EM-F990342. 	EM-F990342
Rev. 5	Sep. 16, 2010	<ol style="list-style-type: none"> 1. The changes filed under this application are adding LCD TV Model XVT3D474SV / VIZIO XVT3D474SV / VIZIO XVT3D474SV-XX collocated with Bluetooth Embedded Module, FCC ID: MDZSV422XVT-BT. And the PCB's electronic circuit changes are described at appendix. 2. Supplementary test data are recorded in test report of EM-F990924. 	EM-F990924

2. GENERAL INFORMATION

2.1. Description of Device (EUT)

Description	:	Bluetooth Embedded Module (With Host LCD TV: VIZIO XVT3D474SV)
Model Number	:	BCM92046MD_EMB
FCC ID	:	MDZSV422XVT-BT
Applicant	:	Amtran Technology Co., Ltd. 17F, No.268, Lien Chen Rd., Chung Ho City, Taipei County, Taiwan, 235 R.O.C.
Fundamental Range	:	2400MHz ~ 2483.5MHz
Channel Number	:	79
Radio Technology	:	FHSS Modulation
Antenna Gain	:	1.87dBi
Date of Receipt of Sample	:	Mar. 01, 2010 & Aug. 23, 2010
Date of Test	:	Mar. 01 ~ Sep. 16, 2010

Information for Class II Permissive Change:

1. This EUT is additional version with original FCC ID MDZSV422XVT-BT.
2. The changes filed under this application are adding LCD TV Model XVT3D474SV / VIZIO XVT3D474SV / VIZIO XVT3D474SV-XX (The "X" is number suffix 0 ~9 or alphabet A ~Z or blank.) collocated with Bluetooth Embedded Module, FCC ID: MDZSV422XVT-BT. And the PCB's electronic circuit changes are described at appendix.
3. The differences among three models of LCD TV are in brand name and marketing purpose, the model VIZIO XVT3D474SV is representative tested in this report of EM-F990924.
4. This report is based on reports of EM-F980571 & EM-F980641 & EM-F990210 & EM-F990320 & EM-F990341.

2.2. Tested Supporting System Details

2.2.1. LCD TV (HOST)

Model Number : VIZIO XVT3D474SV
 Serial Number : N/A
 FCC ID : FCC By DoC
 Manufacturer : VIZIO
 Power Cord : Non-Shielded, Detachable, 1.8m

2.2.2. NOTEBOOK PC

Model Number : PP2130
 Serial Number : 5Y32KSQZ40ME
 BSMI ID : 3912A556
 FCC ID : FCC By DoC
 Manufacturer : LG (Brand Compaq)
 Power Adapter : COMPAQ, M/N PA-1650-02C
 DC Power Cord: Shielded, Undetachable, 1.8m
 Bonded a ferrite core
 AC Power Cord: Non-Shielded, Undetachable, 1.8m

2.3. Description of Test Facility

Name of Firm : **AUDIX Technology Corporation**
EMC Department
 No. 53-11, Tin-Fu Tsun, Lin-Kou Hsiang,
 Taipei County, Taiwan, R.O.C.

Test Site : **Semi-Anechoic Chamber**
 No. 53-11, Tin-Fu Tsun, Lin-Kou Hsiang,
 Taipei Hsien, Taiwan
 May 14, 2009 Renewal on
 Federal Communication Commission
 Registration Number: 90993

NVLAP Lab. Code : 200077-0

TAF Accreditation No : 1724

2.4. Measurement Uncertainty

Test Item	Frequency Range	Uncertainty (dB)
Radiation Test (Distance: 3m)	30MHz~300MHz	±2.91dB
	300MHz~1000MHz	±2.94dB
	Above 1GHz	± 5.02dB

Remark : Uncertainty = $ku_c(y)$

Test Item	Uncertainty
20dB Bandwidth	± 0.2kHz
Carrier Frequency Separation	± 0.2kHz
Time Of Occupancy	± 0.03sec
Maximum peak Output power	± 0.52dBm
Emission Limitations	± 0.13dB
Band Edges	± 0.13dB

3. CONDUCTED EMISSION MEASUREMENT

【The EUT only employs DC power for operation, no conductive emission limits are required according to FCC Part 15 Section §15.207】

4. RADIATED EMISSION MEASUREMENT

4.1. Test Equipment

The following test equipment was used during the radiated emission measurement:

4.1.1. For Frequency 30MHz~1000MHz (at Semi-Anechoic Chamber)

Item	Type	Manufacturer	Model No.	Serial No.	Last Cal.	Next Cal.
1.	Spectrum Analyzer	HP	8564EC	3946A00249	Oct. 27, 09'	Oct. 26, 10'
2.	Test Receiver	R&S	ESCS30	100338	Jul. 08, 10'	Jul. 07, 11'
3.	Pre-Amplifier	HP	8447D	2944A06305	Feb. 03, 10'	Feb. 02, 11'
4.	Biconical Antenna	CHASE	VBA6106A	1264	Mar. 13, 10'	Mar. 12, 11'
5.	Log Periodic Antenna	Schwarzbeck	UHALP9108 -A	0810	Mar. 13, 10'	Mar. 12, 11'

4.1.2. For Frequency Above 1GHz (at Semi-Anechoic Chamber)

Item	Type	Manufacturer	Model No.	Serial No.	Last Cal.	Next Cal.
1.	Spectrum Analyzer	HP	8564EC	3946A00249	Oct. 27, 09'	Oct. 26, 10'
2.	Amplifier	HP	8449B	3008A00529	Dec. 15, 09'	Dec. 14, 10'
3.	Horn Antenna	EMCO	3115	9112-3775	May 10, 10'	May 09, 11'
4.	Horn Antenna	EMCO	3116	2653	Oct. 02, 09'	Oct. 01, 10'

4.2. Test Setup

4.2.1. Block Diagram of connection between EUT and simulators



EUT: Bluetooth Embedded Module

4.2.2. Semi-Anechoic Chamber (3m) Setup Diagram for 30-1000MHz

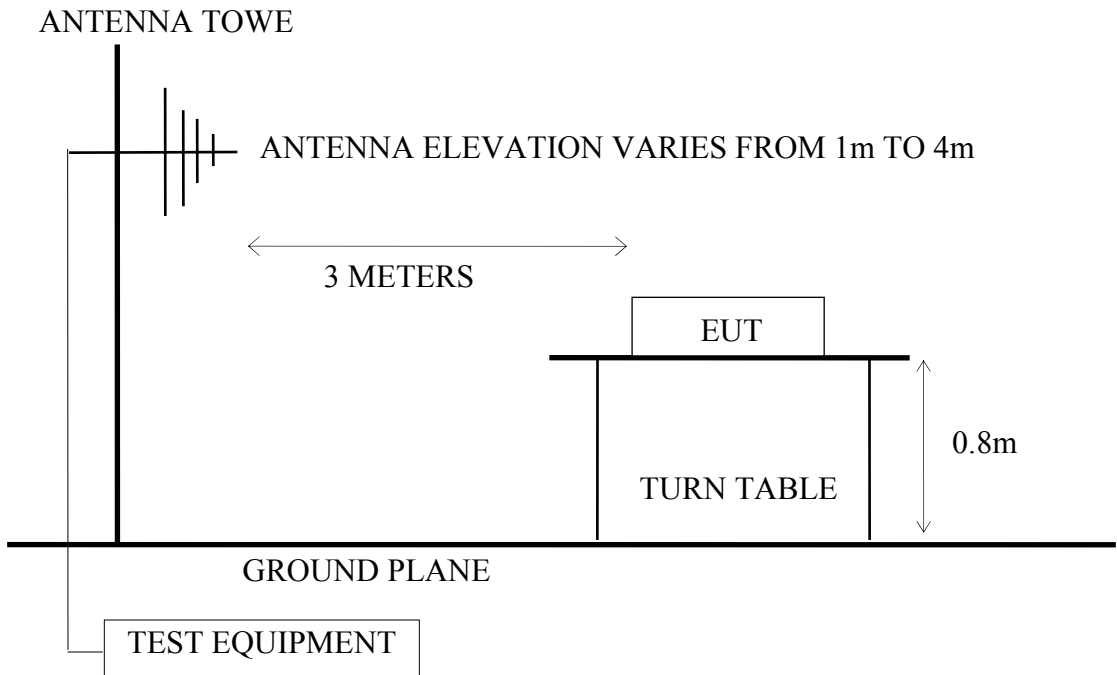

4.2.3. Semi-Anechoic Chamber (3m) Setup Diagram for above 1GHz

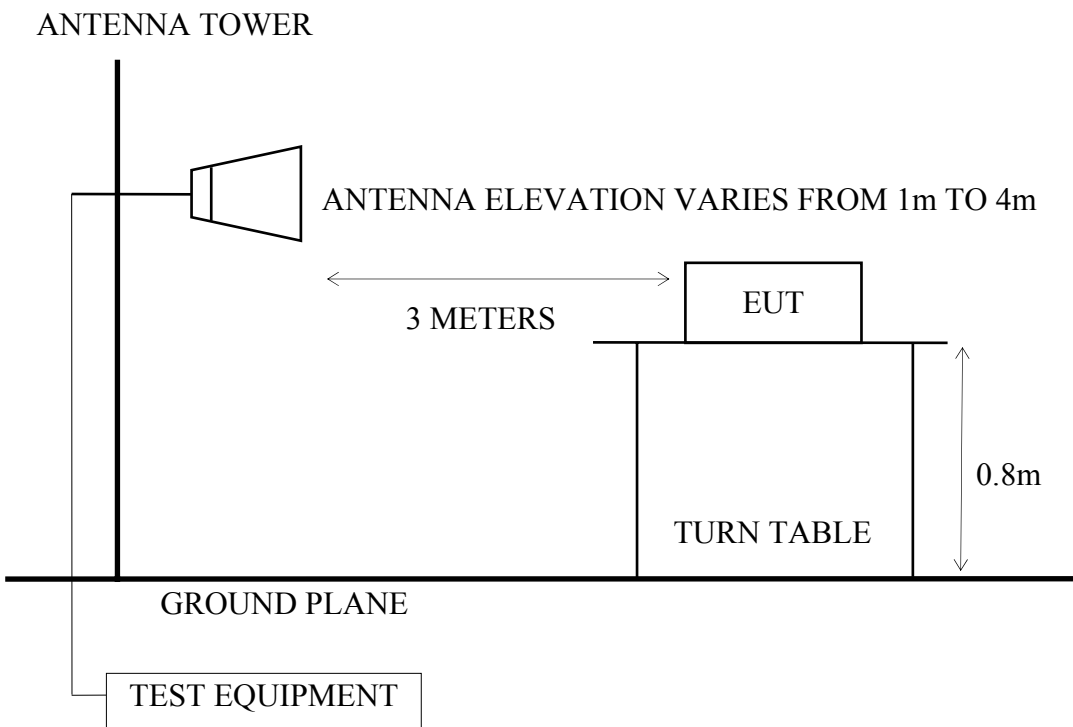

4.3. Radiated Emission Limits (§15.209)

Frequency MHz	Distance Meters	Field Strengths Limits	
		$\mu\text{V/m}$	$\text{dB}\mu\text{V/m}$
30 ~ 88	3	100	40.0
88 ~ 216	3	150	43.5
216 ~ 960	3	200	46.0
Above 960	3	500	54.0
Above 1000	3	74.0 $\text{dB}\mu\text{V/m}$ (Peak) 54.0 $\text{dB}\mu\text{V/m}$ (Average)	

- Remark :
- (1) Emission level ($\text{dB}\mu\text{V/m}$) = 20 log Emission level ($\mu\text{V/m}$)
 - (2) The tighter limit applies at the edge between two frequency bands.
 - (3) Distance refers to the distance in meters between the measuring instrument antenna and the closed point of any part of the device or system.
 - (4) The limits in this table are based on CFR 47 Part 15.205(a)(b) and Part 15.209 (a).
 - (5) The over 1GHz limit, FCC limit is used based on CFR 47 Part 15.35 (b) and Part 15.205(b) & Part 15.209(e) and Part 15.207(c).

4.4. Operating Condition of EUT

- 4.4.1. Set up the EUT (Bluetooth Embedded Module) and simulator as shown on 3.2.1.
- 4.4.2. To turn on the power of all equipment.
- 4.4.3. The EUT was set to continuously transmit signals at 2402MHz, 2441MHz and 2480MHz during testing.
- 4.4.4. The EUT was set to continuously receive signals at 2441MHz during testing.

4.5. Test Procedure

The EUT and its simulators were placed on a turn table which was 0.8 meter above the ground. The turn table rotated 360 degrees to determine the position of the maximum emission level. EUT was set to 3 meters away from the receiving antenna which was mounted on an antenna tower. The antenna moved up and down between 1 to 4 meters to find out the maximum emission level. Broadband antenna such as calibrated biconical and log-periodical antennas or horn antenna were used as a receiving antenna. Both horizontal and vertical polarization of the antenna were set on measurement. In order to find the maximum emission, all of the interface cables were manipulated according to FCC ANSI C63.4-2003 regulation.

The bandwidth of the R&S Test Receiver ESCS30 was set at 120kHz. (For 30MHz to 1000MHz)

The resolution bandwidth and video bandwidth of test spectrum analyzer is 1MHz for peak detection (PK) at frequency above 1GHz.

The resolution bandwidth of test spectrum analyzer is 1MHz and the video bandwidth is 3kHz for average detection (AV) at frequency above 1GHz.

The frequency range from 30MHz to 25GHz (Up to 10th harmonics from fundamental frequency) was checked. 30MHz to 1000MHz was measured with Quasi-Peak detector. Above 1GHz was measured with peak and average detector. For average reading in frequency from 5.5G to 25GHz, we checked it in 1 meter distance and with a shorter cable 2 meter instead of original's. There is no signal exist.

4.6. Radiated Emission Measurement Results

PASSED. All the emissions not reported below are too low against the official limits.

EUT : Bluetooth Embedded Module M/N : BCM92046MD_EMB

Test Date : Sep. 15, 2010 Temperature : 27 °C Humidity : 54 %

For Frequency Range 30MHz~1000MHz:

[Note: Three types of modulation (GFSK and 8-DPSK and $\pi/4$ -DQPSK) were evaluated but only the worst case (GFSK) was reported in section 4.6.1 & 4.6.2]

The EUT (Bluetooth Embedded Module) with following test modes was performed during this section testing and all the test results are listed in section 4.6.1.

Mode	Host (LCD TV)	Test Mode and Frequency	
1.	VIZIO XVT3D474SV	Transmitting	2402MHz (CH0)
2.			2441MHz (CH39)
3.			2480MHz (CH78)
4.		Receiving	2441MHz (CH39)

Remark 1 : Type of modulation: GFSK.

Remark 2 : All above final readings were measured with Quasi-Peak detector.

For Frequency above 1GHz:

The EUT (Bluetooth Embedded Module) with following test modes was performed during this section testing and all the test results are listed in section 4.6.2.

Mode	Host (LCD TV)	Test Mode and Frequency		Test Frequency Range
1.	VIZIO XVT3D474SV	Transmitting	2402MHz (CH0)	1000-2680MHz
2.				2680-5500MHz
3.				5500-18000MHz
4.				18000-25000MHz
5.		Transmitting	2441MHz (CH39)	1000-2680MHz
6.				2680-5500MHz
7.				5500-18000MHz
8.				18000-25000MHz
9.		Transmitting	2480MHz (CH78)	1000-2680MHz
10.				2680-5500MHz
11.				5500-18000MHz
12.				18000-25000MHz
13.		Receiving	2441MHz (CH39)	1000-2680MHz
14.				2680-5500MHz
15.				5500-18000MHz
16.				18000-25000MHz

Remark 1 : The emissions level were too low against the official limit and not report.

Remark 2 : Type of modulation: GFSK.

For Restricted Bands:

The EUT (Bluetooth Embedded Module) with following test modes was tested in restricted bands and all the test results are listed in section 4.6.3. (The restricted bands defined in part 15.205(a))

Mode	Host (LCD TV)	Type of Modulation	Test Mode and Frequency	Reference Test Data No.		
				Horizontal	Vertical	
1.	VIZIO XVT3D474SV	GFSK	Transmitting	2402MHz (CH0)	# 9, 12	# 10, 11
2.			2480MHz (CH78)	# 16, 13	# 15, 14	
3.		8-DPSK	Transmitting	2402MHz (CH0)	# 1, 4	# 2, 3
4.				2480MHz (CH78)	# 8, 5	# 7, 6

[Note: Two types of modulation (GFSK and 8-DPSK) were reported in section 4.6.3]

Date of Test : Sep. 15, 2010 Temperature : 27°C

EUT : Bluetooth Embedded Module
(With Host LCD TV: VIZIO
XVT3D474SV) Humidity : 54%

Test Mode : Transmitting Mode, Frequency:
2441MHz (CH39)
Type of Modulation: GFSK

Emission Frequency MHz	Antenna Factor dB/m	Cable Loss dB μ V	Meter Reading Horizontal dB μ V/m	Emission Level Horizontal dB μ V/m	Limits dB	Margin
144.460	20.31	2.60	16.42	39.33	43.50	4.17
221.090	21.91	3.30	12.79	38.01	46.00	7.99
301.600	14.59	3.90	18.12	36.61	46.00	9.39
376.290	17.15	4.60	13.43	35.18	46.00	10.82
520.820	19.97	6.90	16.80	43.66	46.00	2.34
665.350	22.65	6.40	8.27	37.32	46.00	8.68
702.210	23.53	6.50	12.94	42.97	46.00	3.03
749.740	23.25	6.70	12.91	42.86	46.00	3.14
850.620	25.63	7.10	11.22	43.95	46.00	2.05
964.110	26.80	7.60	9.94	44.34	54.00	9.66

Remarks: 1. Emission Level= Antenna Factor + Cable Loss + Reading.
2. The emission levels that are 20dB below the official limit are not reported.

Emission Frequency MHz	Antenna Factor dB/m	Cable Loss dB μ V	Meter Reading Vertical dB μ V/m	Emission Level Vertical dB μ V/m	Limits dB	Margin
127.000	19.56	2.40	15.14	37.10	43.50	6.40
169.680	21.01	2.80	9.15	32.96	43.50	10.54
369.500	16.93	4.60	14.34	35.87	46.00	10.13
519.850	19.99	6.90	13.21	40.10	46.00	5.90
534.400	19.57	7.00	12.34	38.91	46.00	7.09
593.570	20.95	6.20	8.28	35.43	46.00	10.57
665.350	22.65	6.40	9.98	39.03	46.00	6.97
702.210	23.53	6.50	10.45	40.48	46.00	5.52
929.190	24.92	7.50	5.54	37.96	46.00	8.04
964.110	26.80	7.60	6.00	40.40	54.00	13.60

Remarks: 1. Emission Level= Antenna Factor + Cable Loss + Reading.
2. The emission levels that are 20dB below the official limit are not reported.

Date of Test : Sep. 15, 2010 Temperature : 27°C

EUT : Bluetooth Embedded Module
(With Host LCD TV: VIZIO
XVT3D474SV) Humidity : 54%

Test Mode : Transmitting Mode, Frequency:
2480MHz (CH78)
Type of Modulation: GFSK

Emission Frequency MHz	Antenna Factor dB/m	Cable Loss dB μ V	Meter Reading Horizontal dB μ V/m	Emission Level Horizontal dB μ V/m	Limits dB	Margin
142.520	20.26	2.50	17.41	40.18	43.50	3.32
221.090	21.91	3.30	11.66	36.88	46.00	9.12
334.580	15.09	4.20	13.78	33.07	46.00	12.93
373.380	17.13	4.60	12.80	34.54	46.00	11.46
515.000	19.97	6.80	16.09	42.86	46.00	3.14
534.400	19.57	7.00	11.43	38.00	46.00	8.00
676.020	22.89	6.40	9.83	39.11	46.00	6.89
712.880	23.30	6.53	14.15	43.98	46.00	2.02
750.710	23.35	6.70	14.40	44.45	46.00	1.55
964.110	26.80	7.60	8.50	42.90	54.00	11.10

Remarks: 1. Emission Level= Antenna Factor + Cable Loss + Reading.
2. The emission levels that are 20dB below the official limit are not reported.

Emission Frequency MHz	Antenna Factor dB/m	Cable Loss dB μ V	Meter Reading Vertical dB μ V/m	Emission Level Vertical dB μ V/m	Limits dB	Margin
127.000	19.56	2.40	14.72	36.68	43.50	6.82
164.830	20.89	2.70	8.92	32.51	43.50	10.99
382.110	17.29	4.60	12.17	34.06	46.00	11.94
519.850	19.99	6.90	12.26	39.15	46.00	6.85
600.360	21.31	6.30	8.69	36.30	46.00	9.70
667.290	22.80	6.40	9.66	38.86	46.00	7.14
702.210	23.53	6.50	11.88	41.91	46.00	4.09
770.110	23.93	6.80	8.17	38.91	46.00	7.09
931.130	25.11	7.50	4.27	36.87	46.00	9.13
964.110	26.80	7.60	4.34	38.74	54.00	15.26

Remarks: 1. Emission Level= Antenna Factor + Cable Loss + Reading.
2. The emission levels that are 20dB below the official limit are not reported.

Date of Test : Sep. 15, 2010 Temperature : 27°C

EUT : Bluetooth Embedded Module
(With Host LCD TV: VIZIO
XVT3D474SV) Humidity : 54%

Test Mode : Receiving Mode, Frequency:
2441MHz (CH39)
Type of Modulation: GFSK

Emission Frequency MHz	Antenna Factor dB/m	Cable Loss dB μ V	Meter Reading Horizontal dB μ V/m	Emission Level Horizontal dB μ V/m	Limits dB	Margin
129.910	19.73	2.40	15.83	37.96	43.50	5.54
147.370	20.53	2.58	17.12	40.24	43.50	3.26
221.090	21.91	3.30	11.73	36.95	46.00	9.05
301.600	14.59	3.90	17.45	35.94	46.00	10.06
371.440	17.08	4.60	13.05	34.73	46.00	11.27
519.850	19.99	6.90	16.87	43.76	46.00	2.24
665.350	22.65	6.40	8.94	37.99	46.00	8.01
712.880	23.30	6.53	11.20	41.03	46.00	4.97
750.710	23.35	6.70	13.42	43.47	46.00	2.53
859.350	26.01	7.20	10.97	44.17	46.00	1.83
964.110	26.80	7.60	8.36	42.76	54.00	11.24

Remarks: 1. Emission Level= Antenna Factor + Cable Loss + Reading.
2. The emission levels that are 20dB below the official limit are not reported.

Emission Frequency MHz	Antenna Factor dB/m	Cable Loss dB μ V	Meter Reading Vertical dB μ V/m	Emission Level Vertical dB μ V/m	Limits dB	Margin
126.030	19.49	2.38	15.32	37.18	43.50	6.32
294.810	26.43	3.99	4.15	34.57	46.00	11.43
357.860	15.90	4.40	13.84	34.14	46.00	11.86
400.540	17.66	4.80	11.58	34.04	46.00	11.96
519.850	19.99	6.90	14.00	40.89	46.00	5.11
593.570	20.95	6.20	9.12	36.27	46.00	9.73
667.290	22.80	6.40	9.31	38.51	46.00	7.49
702.210	23.53	6.50	10.73	40.76	46.00	5.24
770.110	23.93	6.80	6.52	37.26	46.00	8.74
933.070	25.23	7.50	5.24	37.97	46.00	8.03
963.140	26.63	7.60	5.18	39.41	54.00	14.59

Remarks: 1. Emission Level= Antenna Factor + Cable Loss + Reading.
2. The emission levels that are 20dB below the official limit are not reported.

4.6.2. Above 1GHz Frequency Range Measurement Results

The emissions level were too low against the official limit and not report.

4.6.3. Restricted Bands Measurement Results

Date of Test : Sep. 15, 2010 Temperature : 27°C

EUT : Bluetooth Embedded Module Humidity : 54%
 (With Host LCD TV: VIZIO
 XVT3D474SV)

Test Mode : Transmitting Mode, Frequency:
 2402MHz (CH0)
 Type of Modulation: GFSK

	Emission Frequency MHz	Antenna Factor dB/m	Cable Loss dB μ V	Meter Reading Horizontal dB μ V/m	Emission Level Horizontal dB μ V/m	Limits dB	Margin
Fundamental	2402.070	28.10	6.36	54.77	89.23		
Peak *	2383.040	28.08	6.33	1.35	35.76	74.00	38.24
Fundamental	2402.070	28.10	6.36	53.19	87.65		
Average *	2376.770	28.08	6.32	-8.47	25.93	54.00	28.07

- Remark : 1. Emission Level = Antenna Factor + Cable Loss + Meter Reading.
 2. Low frequency section (spurious in the restricted band 2310-2420MHz).
 3. '*' The field strength of emission appearing within Part 15.205(a) shall not exceed the limits shown in section 15.209.

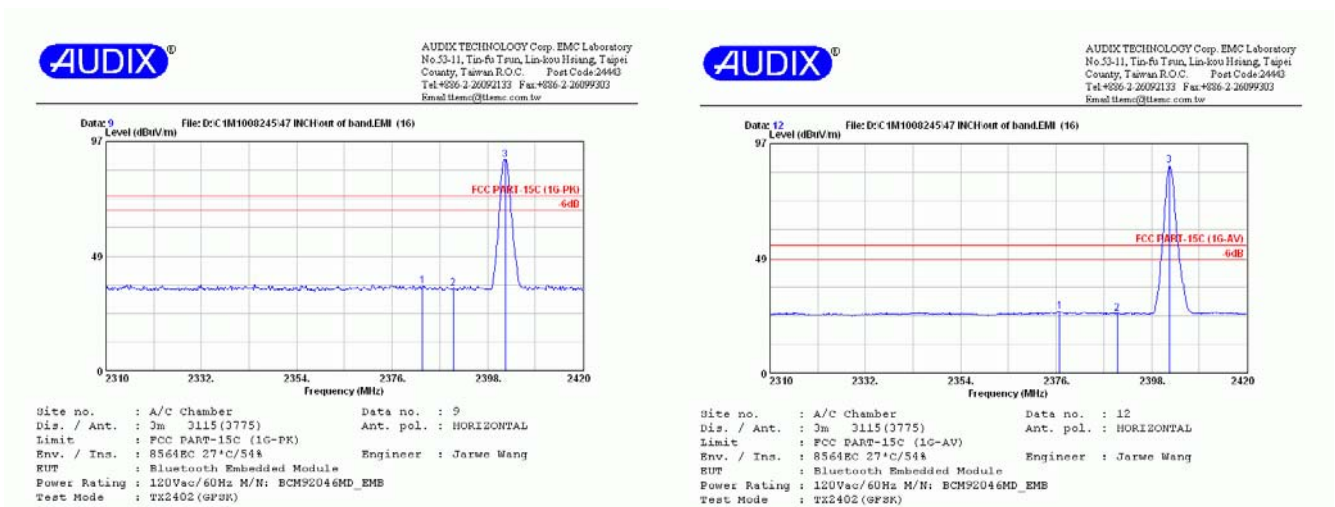

Date of Test : Sep. 15, 2010 Temperature : 27°C

EUT : Bluetooth Embedded Module
(With Host LCD TV: VIZIO
XVT3D474SV) Humidity : 54%

Test Mode : Transmitting Mode, Frequency:
2402MHz (CH0)
Type of Modulation: GFSK

	Emission Frequency MHz	Antenna Factor dB/m	Cable Loss dB μ V	Meter Reading Vertical dB μ V/m	Emission Level Vertical dB μ V/m	Limits dB	Margin
Fundamental	2402.290	28.10	6.36	57.74	92.20		
Peak *	2384.470	28.08	6.33	1.85	36.26	74.00	37.74
Fundamental	2402.290	28.10	6.36	54.43	88.89		
Average *	2386.120	28.10	6.33	-8.56	25.87	54.00	28.13

- Remark : 1. Emission Level = Antenna Factor + Cable Loss + Meter Reading.
 2. Low frequency section (spurious in the restricted band 2310-2420MHz).
 3. '*' The field strength of emission appearing within Part 15.205(a) shall not exceed the limits shown in section 15.209.

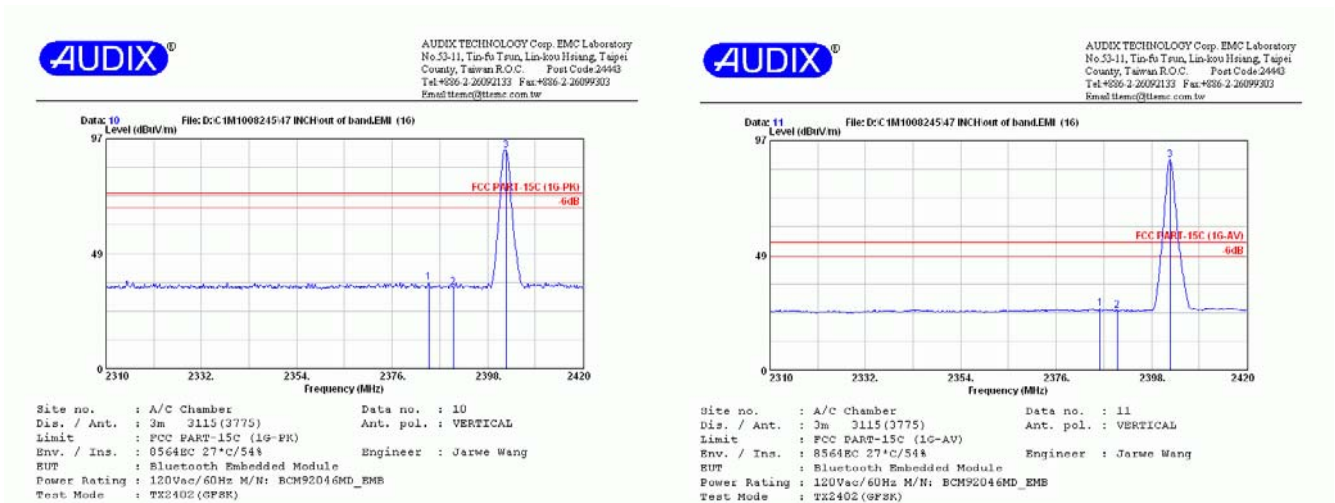

Date of Test : Sep. 15, 2010 Temperature : 27°C

EUT : Bluetooth Embedded Module
(With Host LCD TV: VIZIO
XVT3D474SV) Humidity : 54%

Test Mode : Transmitting Mode, Frequency:
2480MHz (CH78)
Type of Modulation: GFSK

	Emission Frequency MHz	Antenna Factor dB/m	Cable Loss dB μ V	Meter Reading Horizontal dB μ V/m	Emission Level Horizontal dB μ V/m	Limits dB	Margin
Fundamental	2480.140	28.18	6.44	54.11	88.73		
Peak *	2483.560	28.18	6.45	1.34	35.97	74.00	38.03
Fundamental	2480.020	28.18	6.44	53.76	88.38		
Average *	2483.620	28.18	6.45	-1.10	33.53	54.00	20.47

- Remark : 1. Emission Level = Antenna Factor + Cable Loss + Meter Reading.
 2. Low frequency section (spurious in the restricted band 2470-2530MHz).
 3. '*' The field strength of emission appearing within Part 15.205(a) shall not exceed the limits shown in section 15.209.

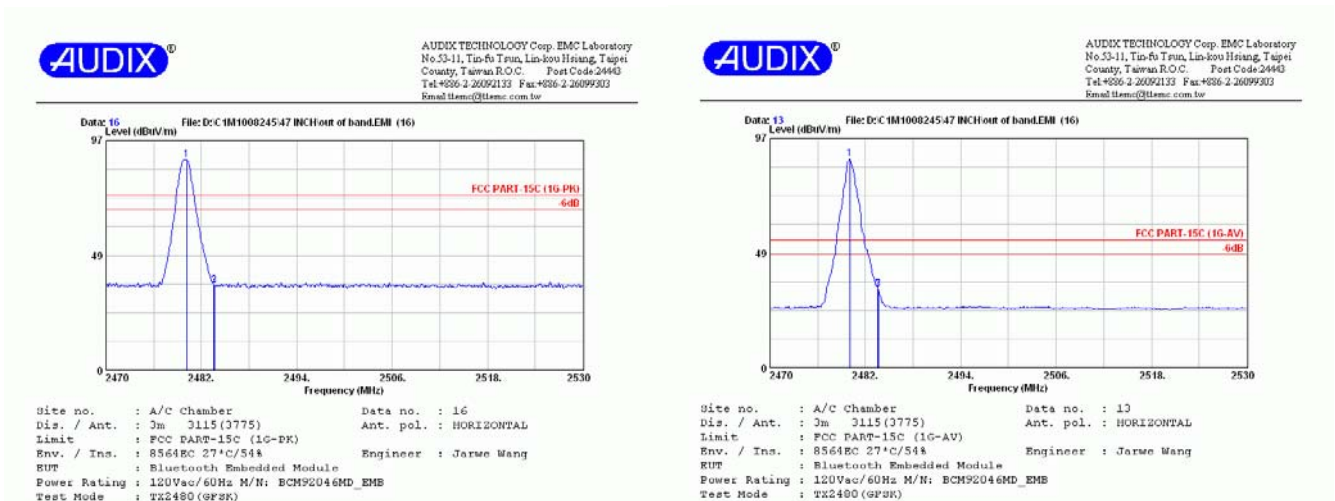

Date of Test : Sep. 15, 2010 Temperature : 27°C

EUT : Bluetooth Embedded Module
(With Host LCD TV: VIZIO
XVT3D474SV) Humidity : 54%

Test Mode : Transmitting Mode, Frequency:
2480MHz (CH78)
Type of Modulation: GFSK

	Emission Frequency MHz	Antenna Factor dB/m	Cable Loss dB μ V	Meter Reading Vertical dB μ V/m	Emission Level Vertical dB μ V/m	Limits dB	Margin
Fundamental	2480.140	28.18	6.44	58.41	93.03		
Peak *	2483.560	28.18	6.45	36.11	36.77	74.00	37.23
Fundamental	2480.020	28.18	6.44	51.29	86.77		
Average *	2483.560	28.18	6.45	-1.53	33.10	54.00	20.90

- Remark : 1. Emission Level = Antenna Factor + Cable Loss + Meter Reading.
 2. Low frequency section (spurious in the restricted band 2470-2530MHz).
 3. '*' The field strength of emission appearing within Part 15.205(a) shall not exceed the limits shown in section 15.209.

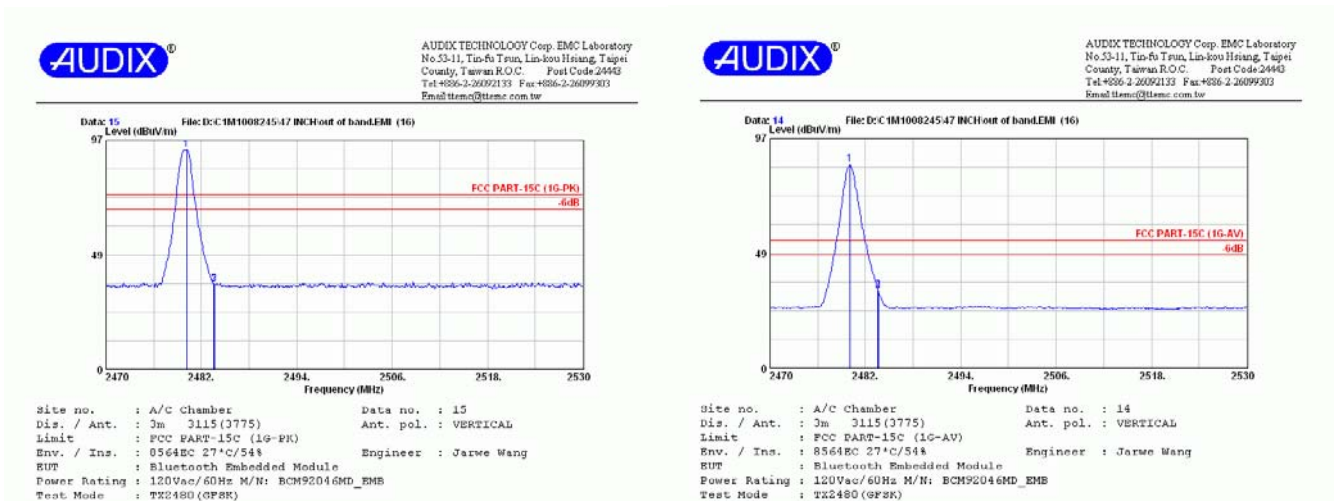

Date of Test : Sep. 15, 2010 Temperature : 27°C

EUT : Bluetooth Embedded Module
(With Host LCD TV: VIZIO
XVT3D474SV) Humidity : 54%

Test Mode : Transmitting Mode, Frequency:
2402MHz (CH0)
Type of Modulation: 8-DPSK

	Emission Frequency MHz	Antenna Factor dB/m	Cable Loss dB μ V	Meter Reading Horizontal dB μ V/m	Emission Level Horizontal dB μ V/m	Limits dB	Margin
Fundamental	2402.620	28.11	6.36	51.95	86.12		
Peak *	2389.970	28.10	6.34	0.73	37.17	74.00	36.83
Fundamental	2402.290	28.10	6.36	48.91	82.92		
Average *	2375.670	28.08	6.32	-8.42	26.17	54.00	27.83

- Remark : 1. Emission Level = Antenna Factor + Cable Loss + Meter Reading.
 2. Low frequency section (spurious in the restricted band 2310-2420MHz).
 3. '*' The field strength of emission appearing within Part 15.205(a) shall not exceed the limits shown in section 15.209.

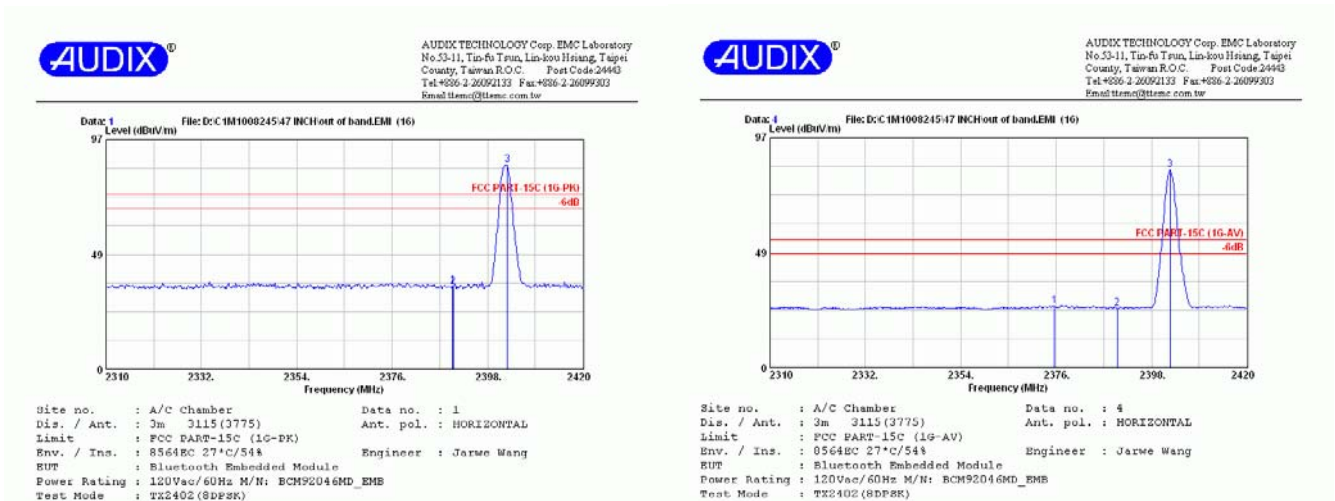

Date of Test : Sep. 15, 2010 Temperature : 27°C

EUT : Bluetooth Embedded Module
(With Host LCD TV: VIZIO
XVT3D474SV) Humidity : 54%

Test Mode : Transmitting Mode, Frequency:
2402MHz (CH0)
Type of Modulation: 8-DPSK

	Emission Frequency MHz	Antenna Factor dB/m	Cable Loss dB μ V	Meter Reading Vertical dB μ V/m	Emission Level Vertical dB μ V/m	Limits dB	Margin
Fundamental	2402.070	28.10	6.36	54.53	89.78		
Peak *	2363.790	28.06	6.30	2.72	36.77	74.00	37.23
Fundamental	2402.290	28.10	6.36	51.15	85.75		
Average *	2389.420	28.10	6.34	-8.07	26.15	54.00	27.85

- Remark : 1. Emission Level = Antenna Factor + Cable Loss + Meter Reading.
 2. Low frequency section (spurious in the restricted band 2310-2420MHz).
 3. '*' The field strength of emission appearing within Part 15.205(a) shall not exceed the limits shown in section 15.209.

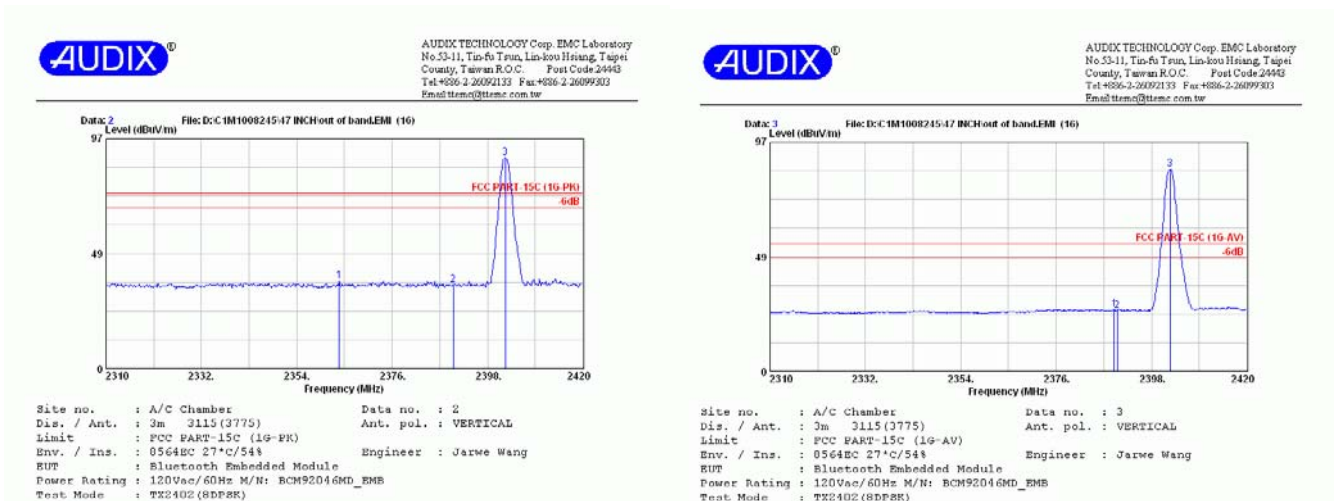

Date of Test : Sep. 15, 2010 Temperature : 27°C

EUT : Bluetooth Embedded Module
(With Host LCD TV: VIZIO
XVT3D474SV) Humidity : 54%

Test Mode : Transmitting Mode, Frequency:
2480MHz (CH78)
Type of Modulation: 8-DPSK

	Emission Frequency MHz	Antenna Factor dB/m	Cable Loss dB μ V	Meter Reading Horizontal dB μ V/m	Emission Level Horizontal dB μ V/m	Limits dB	Margin
Fundamental	2479.840	28.18	6.44	52.16	86.78		
Peak *	2483.560	28.18	6.45	4.19	38.82	74.00	35.18
Fundamental	2479.840	28.18	6.44	47.19	81.81		
Average *	2483.560	28.18	6.45	1.40	36.03	54.00	17.97

- Remark : 1. Emission Level = Antenna Factor + Cable Loss + Meter Reading.
 2. Low frequency section (spurious in the restricted band 2470-2530MHz).
 3. '*' The field strength of emission appearing within Part 15.205(a) shall not exceed the limits shown in section 15.209.

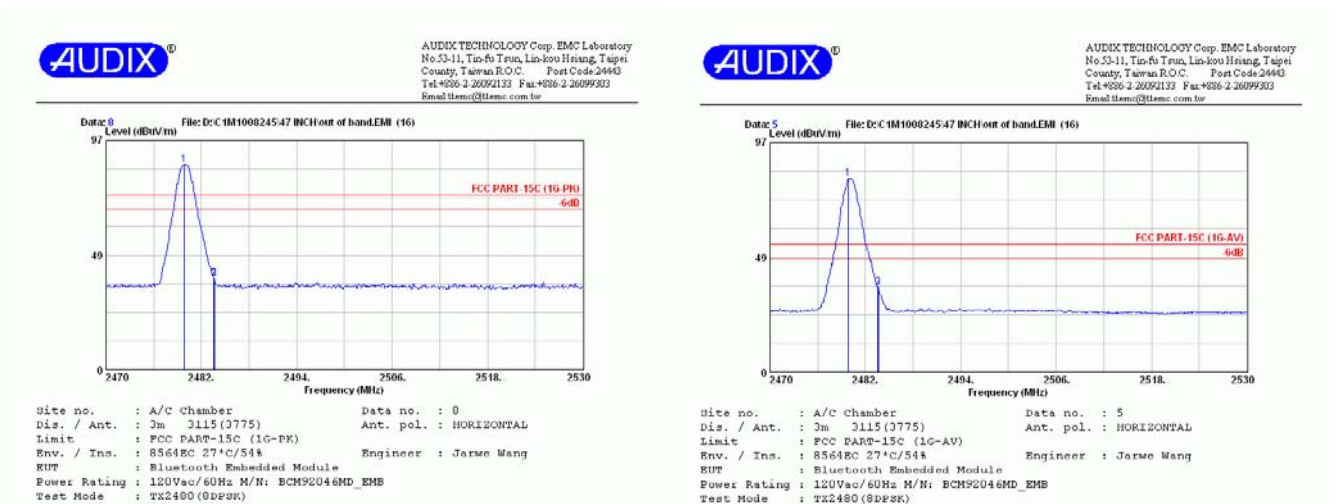

Date of Test : Sep. 15, 2010 Temperature : 27°C

EUT : Bluetooth Embedded Module
(With Host LCD TV: VIZIO
XVT3D474SV) Humidity : 54%

Test Mode : Transmitting Mode, Frequency:
2480MHz (CH78)
Type of Modulation: 8-DPSK

	Emission Frequency MHz	Antenna Factor dB/m	Cable Loss dBμV	Meter Reading Vertical dBμV/m	Emission Level Vertical dBμV/m	Limits dB	Margin
Fundamental	2480.320	28.18	6.44	54.36	88.98		
Peak *	2483.560	28.18	6.45	4.58	39.21	74.00	34.79
Fundamental	2480.020	28.18	6.44	49.78	84.40		
Average *	2483.560	28.18	6.45	1.57	36.20	54.00	17.80

- Remark : 1. Emission Level = Antenna Factor + Cable Loss + Meter Reading.
 2. Low frequency section (spurious in the restricted band 2470-2530MHz).
 3. '*' The field strength of emission appearing within Part 15.205(a) shall not exceed the limits shown in section 15.209.



5. MAXIMUM PEAK OUTPUT POWER MEASUREMENT

5.1. Test Equipment

The following test equipment was used during the maximum peak output power measurement:

Item	Type	Manufacturer	Model No.	Serial No.	Last Cal.	Next Cal.
1.	Power Meter	Antrisu	ML2487A	6K00005406	Feb. 11, 10'	Feb. 10, 11'
2.	Power Sensor	Antrisu	MA2491A	030873	Feb. 11, 10'	Feb. 10, 11'

5.2. Block Diagram of Test Setup

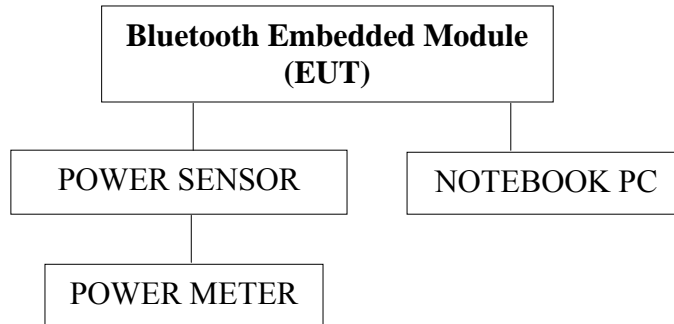

5.3. Specification Limits (§15.247(b)-(1))

The Limits of maximum Peak Output Power for frequency hopping systems in 2400-2483.5MHz is: 0.125Watt. (21dBm)

5.4. Operating Condition of EUT

- 5.4.1. Set up the EUT and simulator as shown on 5.2.
- 5.4.2. To turn on the power of all equipment.
- 5.4.3. The EUT (Bluetooth Embedded Module) was on transmitting frequency function during the testing.

5.5. Test Procedure follow DA00-705

The transmitter output was connected to the spectrum analyzer.
 Span can encompass the waveform
 RBW=VBW=1MHz
 Sweep=Auto

5.6. Test Results

PASSED. All the test results are attached in next pages.

[Note: Two types of modulation (GFSK and 8-DPSK) were reported in this report.]

EUT : Bluetooth Embedded Module M/N : BCM92046MD_EMB

Test Date : Mar. 01, 2010 Temperature : 23 °C Humidity : 46 %

5.6.1.Type of Modulation: GFSK

No.	Channel	Test Frequency	Peak Output Power	Limit
1.	0	2402MHz	1.26dBm	21dBm
2.	39	2441MHz	1.18dBm	21dBm
3.	78	2480MHz	0.80dBm	21dBm

5.6.2.Type of Modulation: 8-DPSK

No.	Channel	Test Frequency	Peak Output Power	Limit
1.	0	2402MHz	-1.44dBm	21dBm
2.	39	2441MHz	-2.29dBm	21dBm
3.	78	2480MHz	-4.88dBm	21dBm

6. DEVIATION TO TEST SPECIFICATIONS

【NONE】

APPENDIX

Schematic (J1 pine define different)

Original Grant

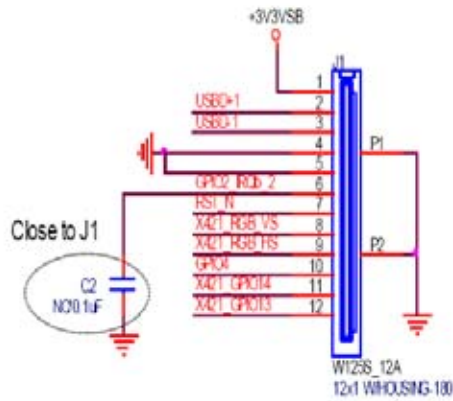

Connector is Normal type

AmTRAN

FOR THIS TIME

