

# Cisco Spark Board 55

Compliance model number: AA55WW

## Installation guide: Floor stand



DRAFT

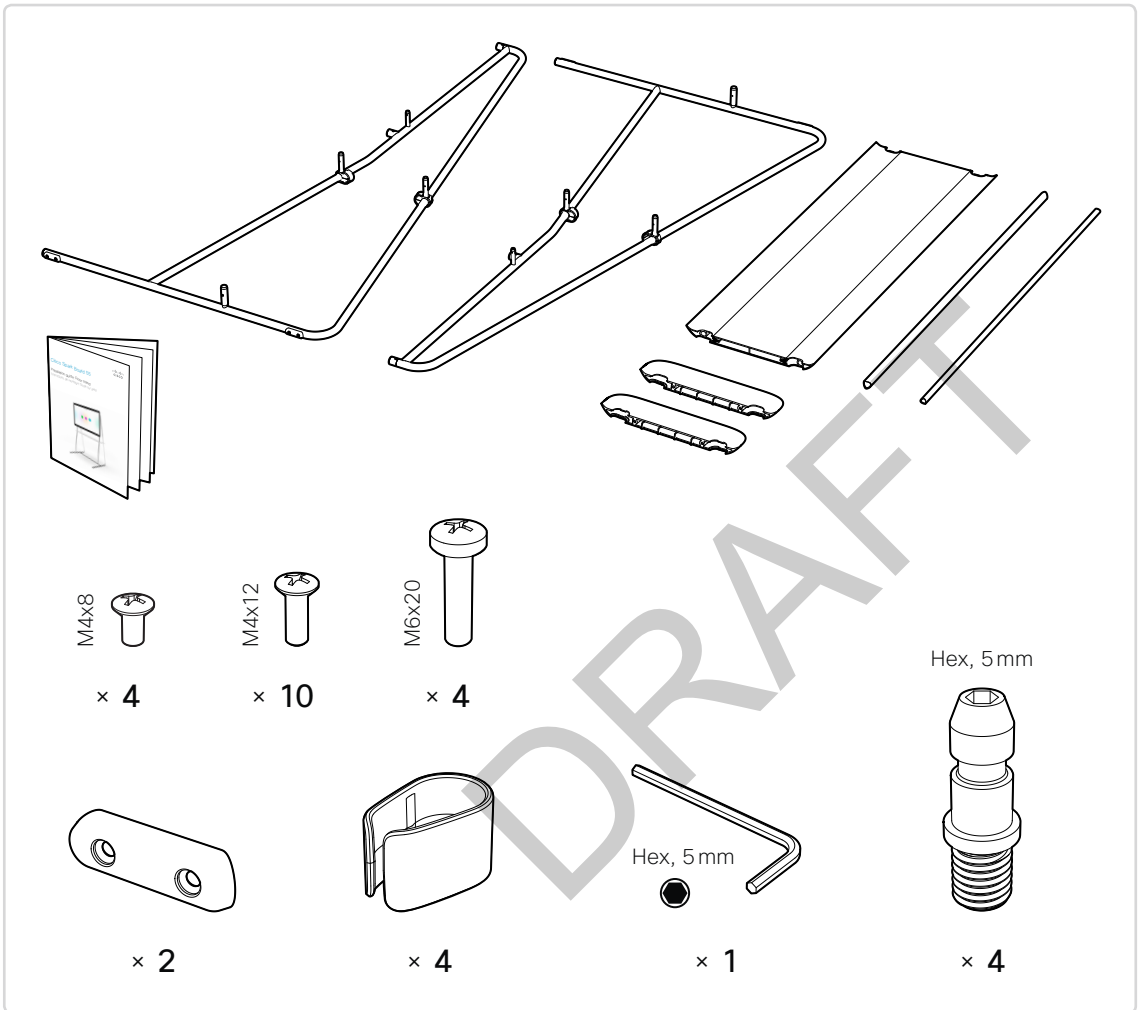
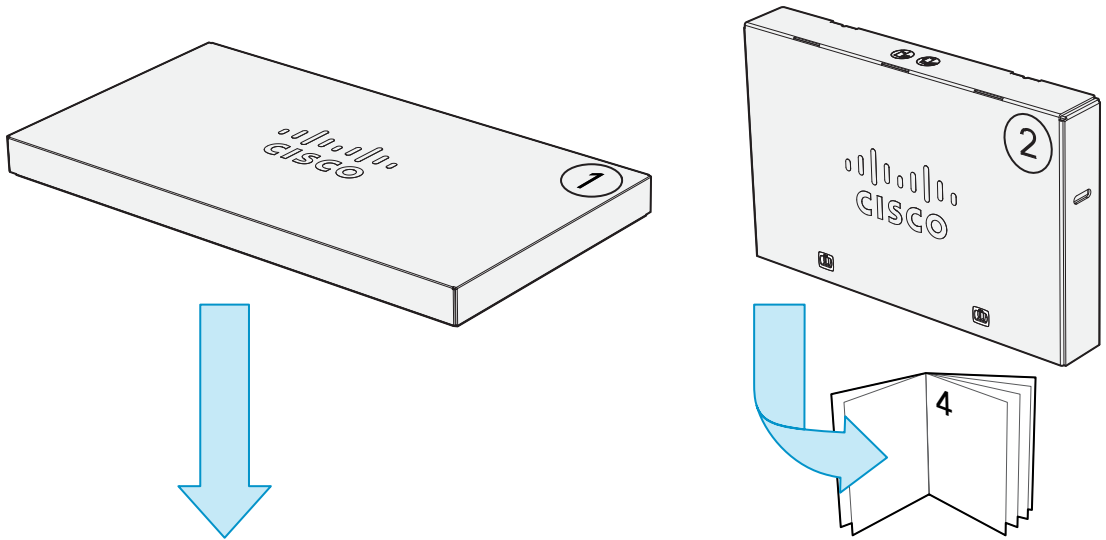



We recommend two people working together to mount this system.  
Follow local regulations.

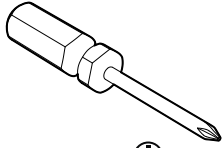

PH2 

DRAFT

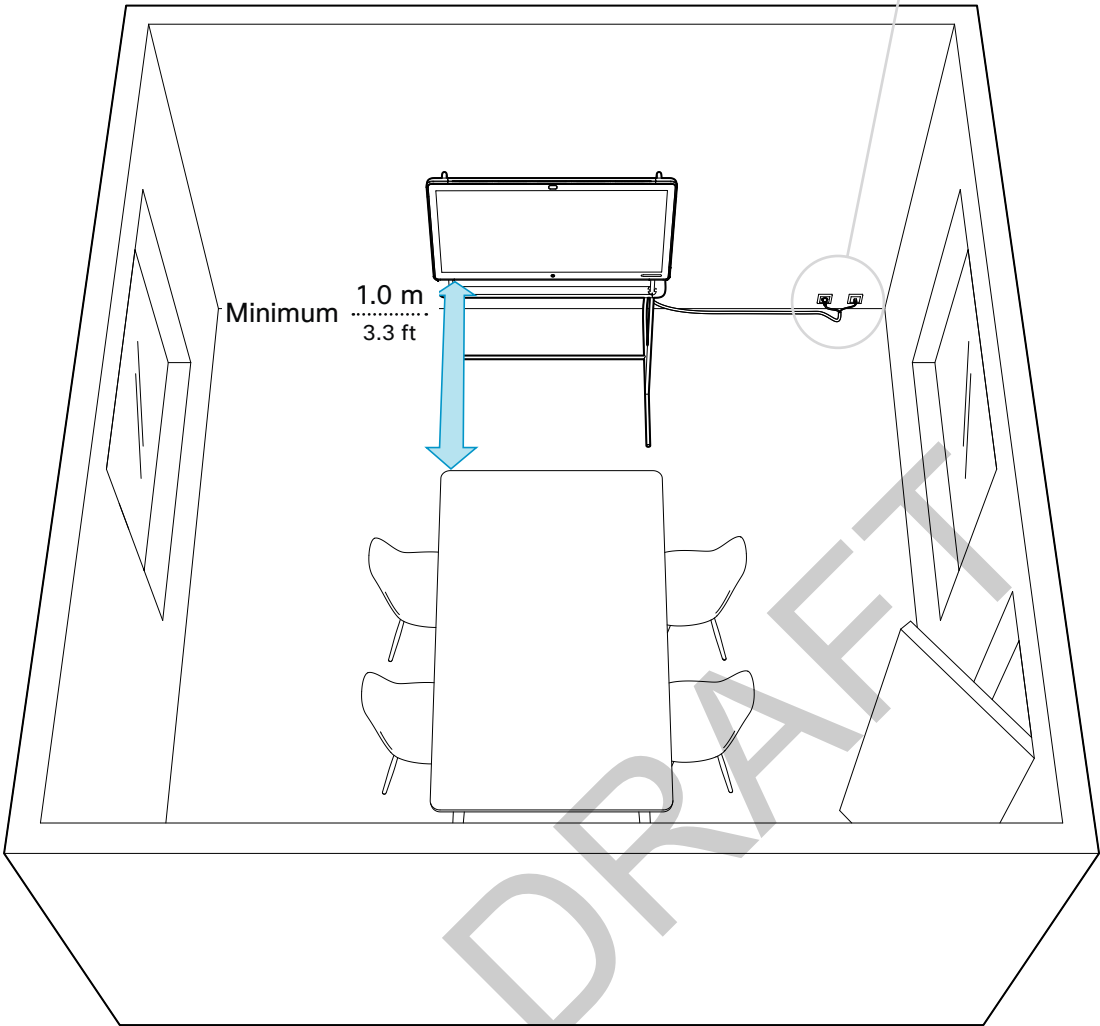
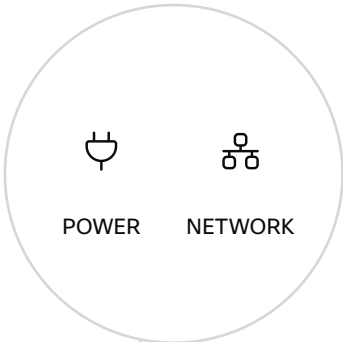

1

M4x12  
PH2



× 5

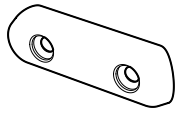

× 1

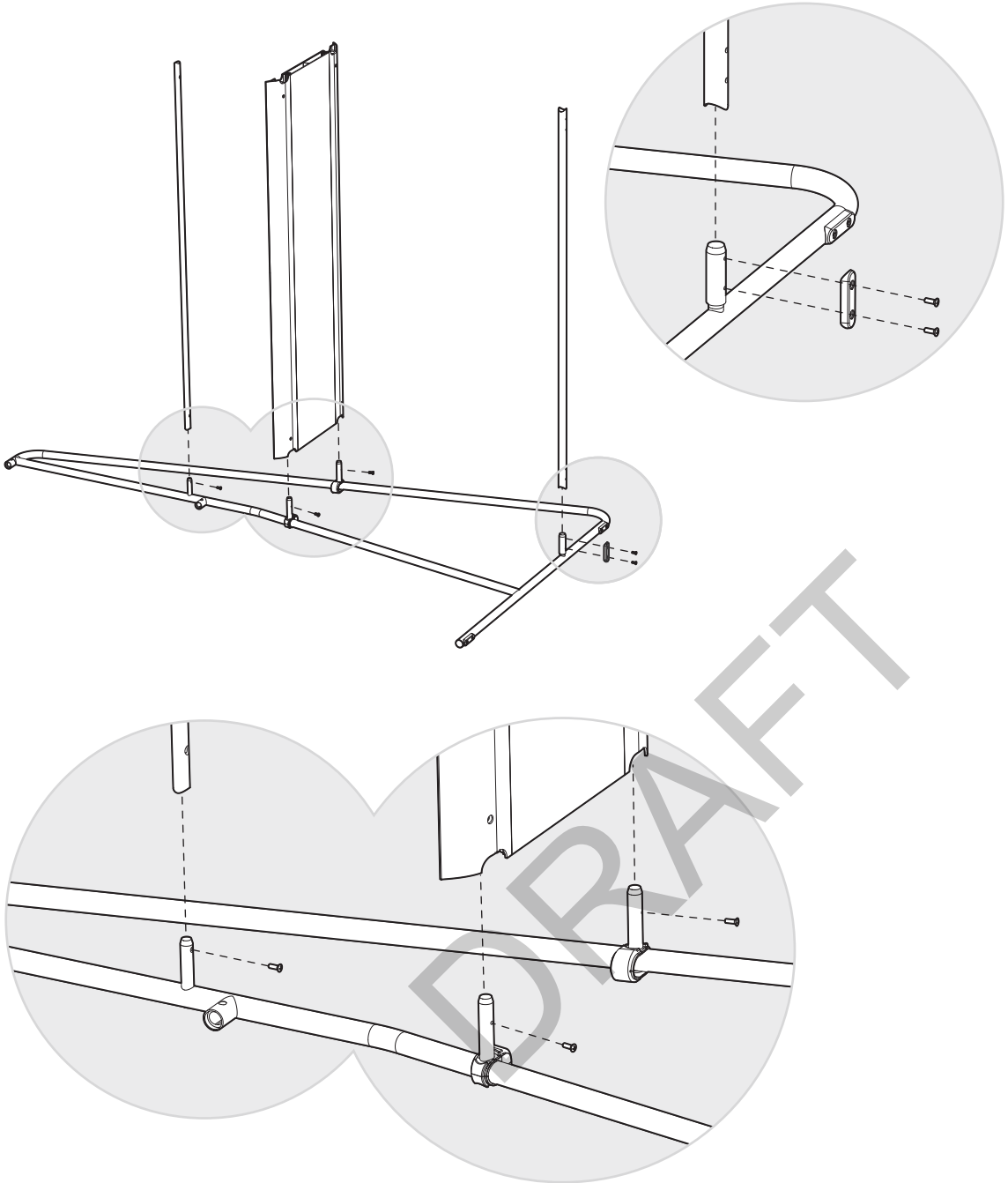

2

M4x12 × 5

PH2

× 1

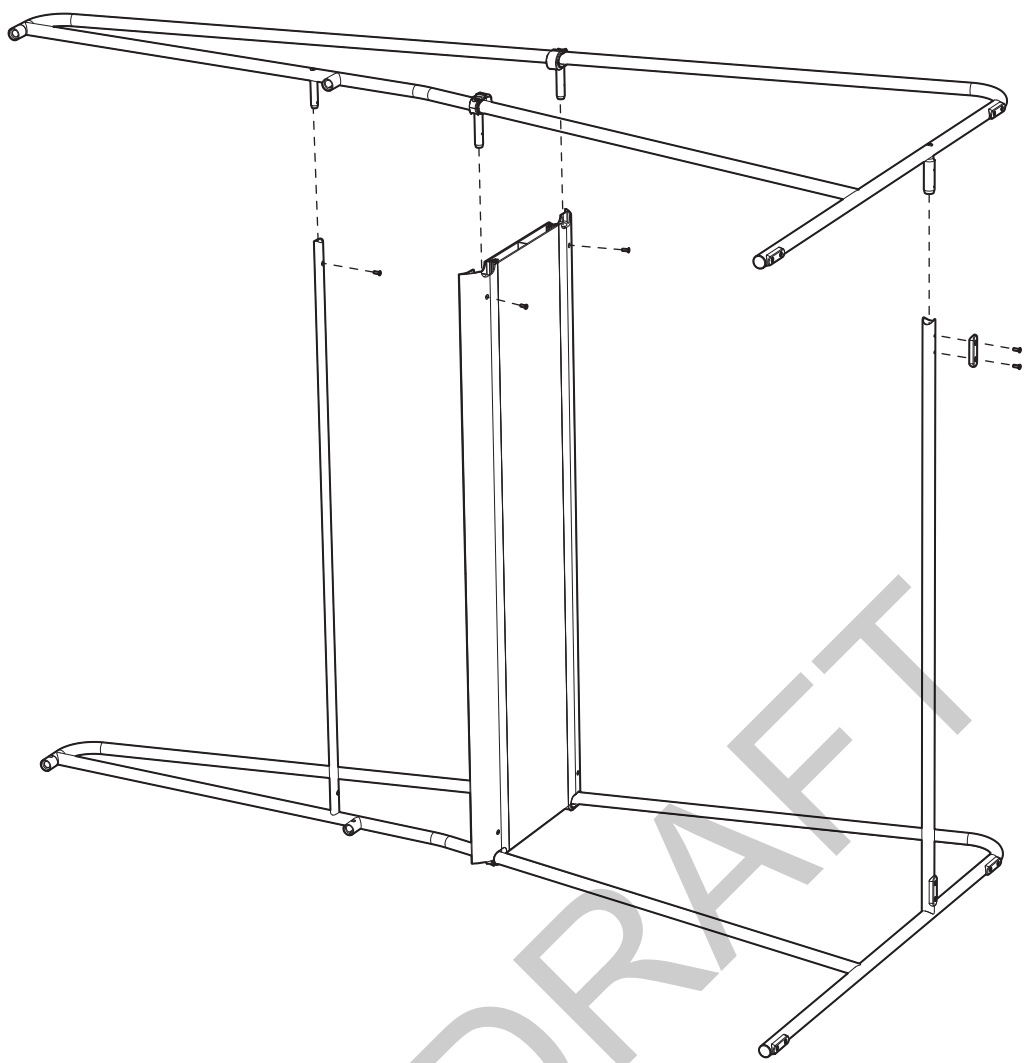

DRAFT

3

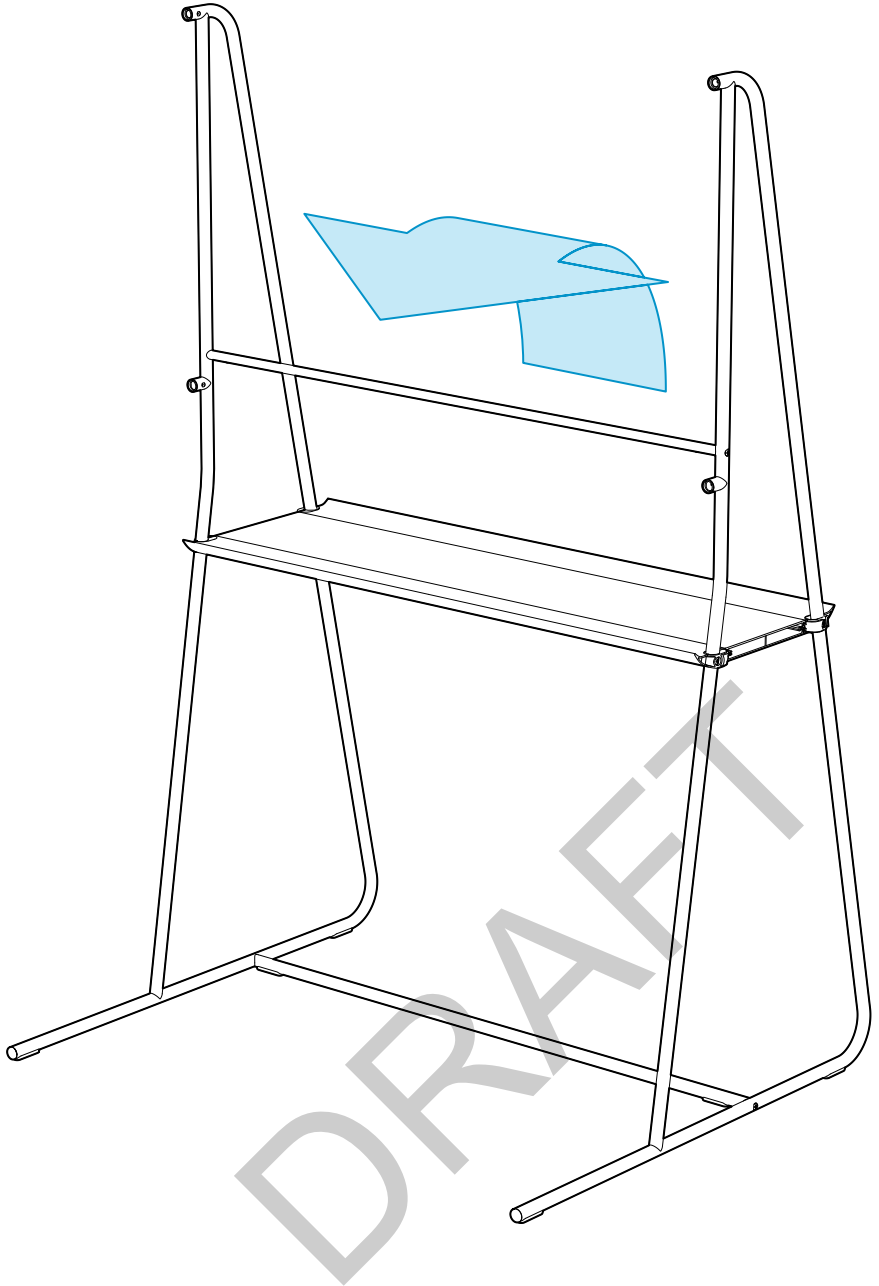



# 4

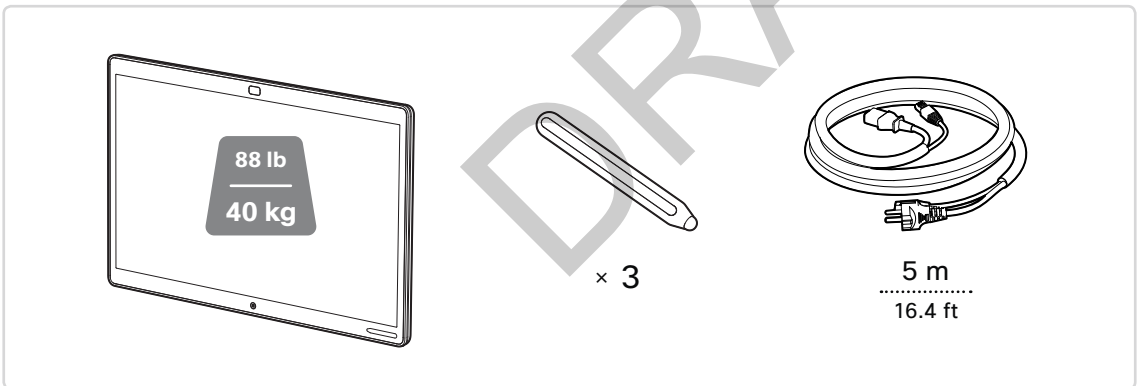
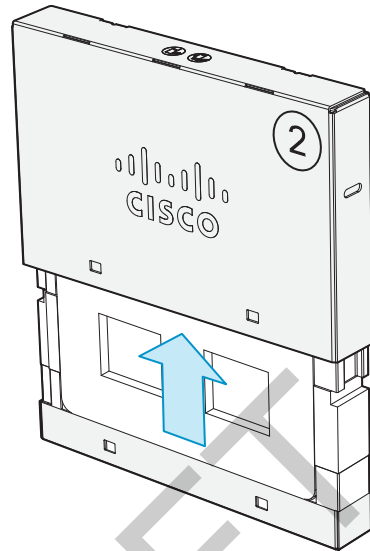
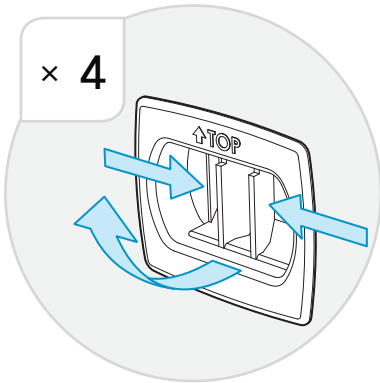
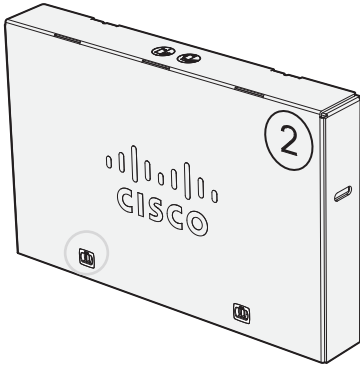

5



88 lb  
40 kg

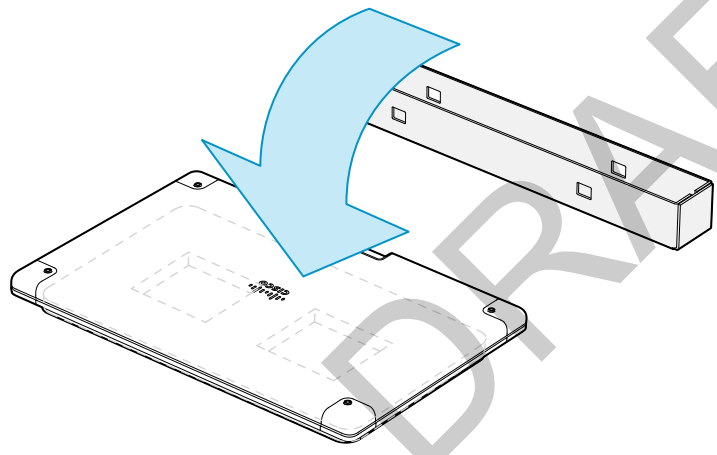
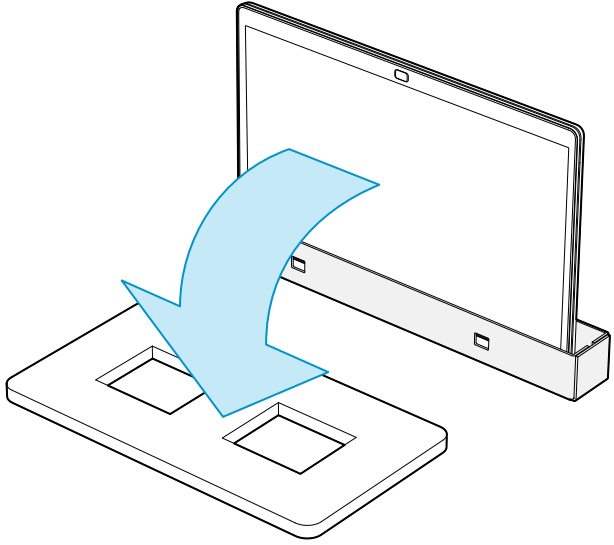

6

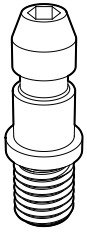

× 4

Hex, 5 mm

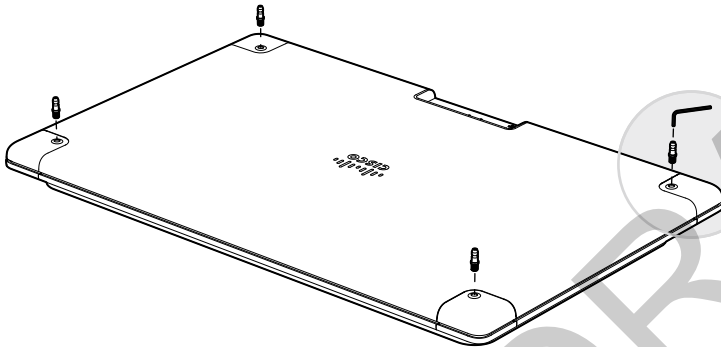
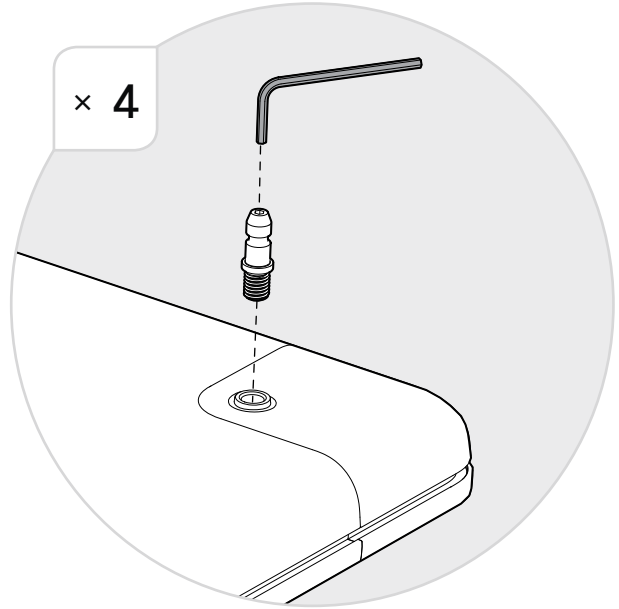

7



88 lb  
40 kg

M4x8 × 4  
PH2

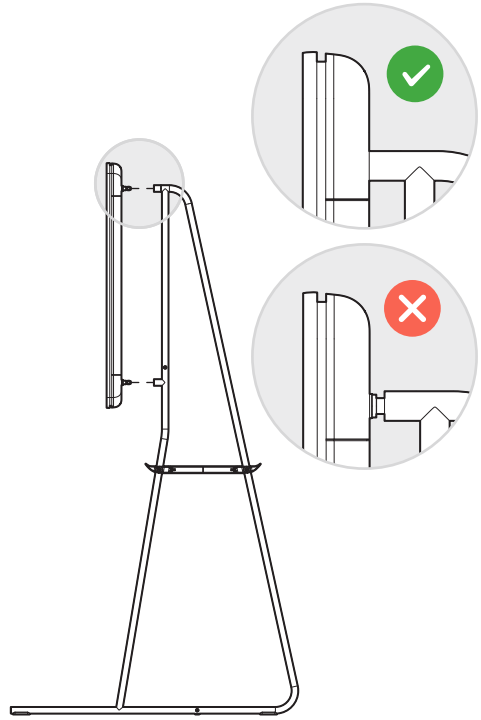
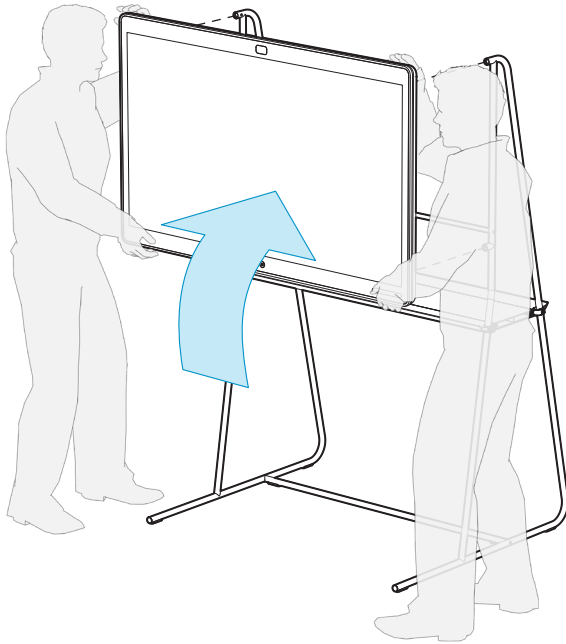

Hold the screen firmly until it is securely fastened with four screws.

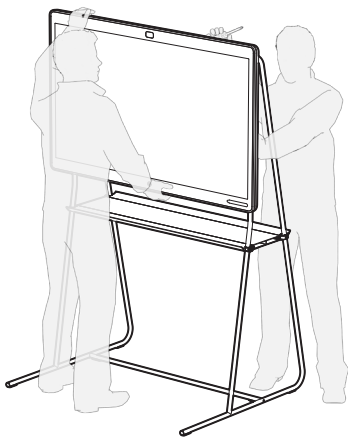

Hold in place

Fasten four screws firmly

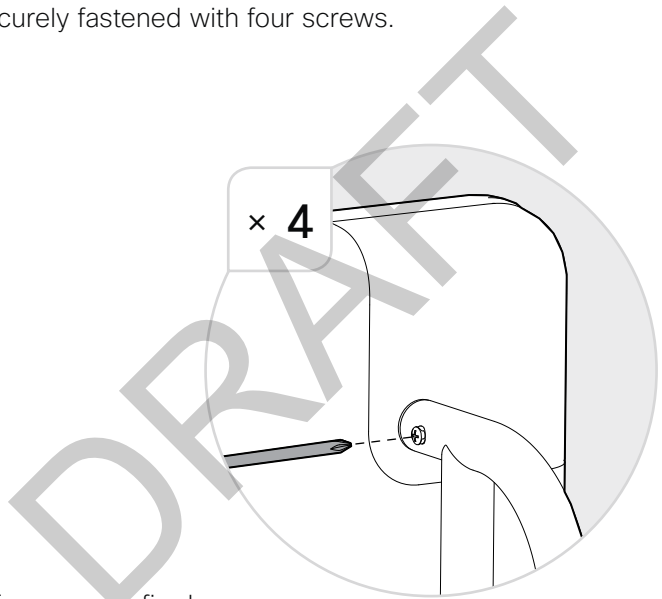

8

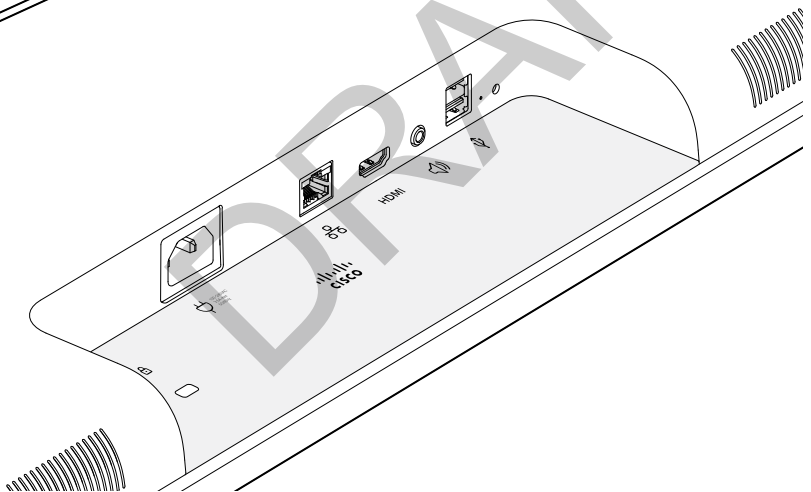
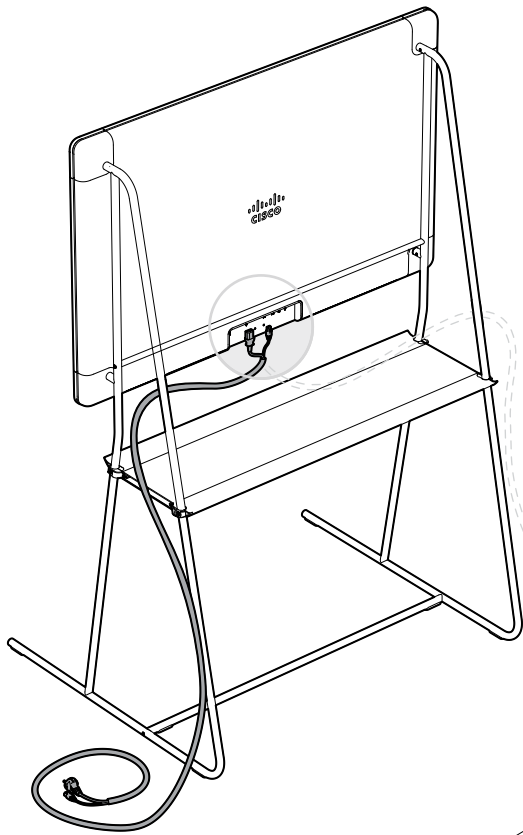
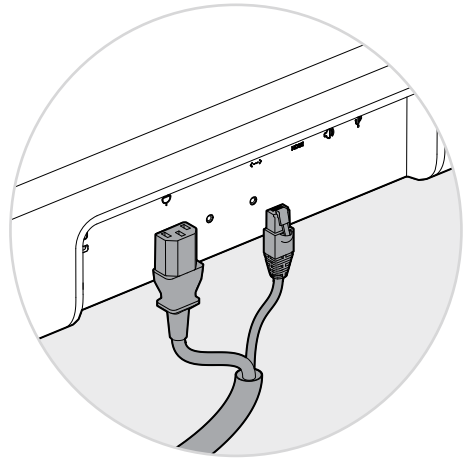
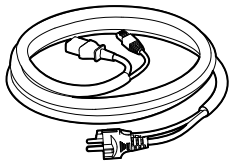

9



× 4

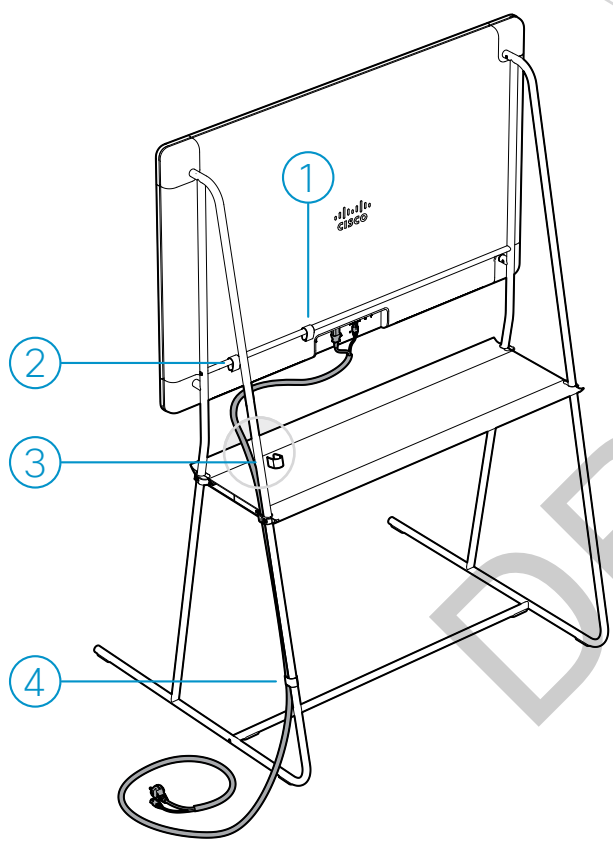
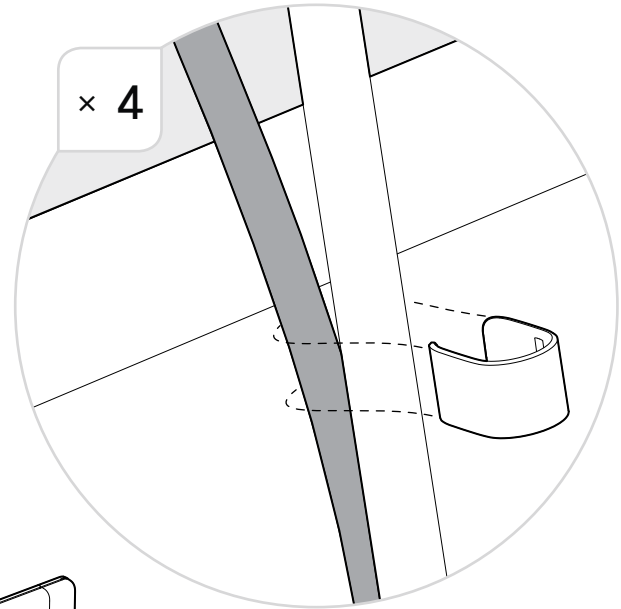

DRAFT

10

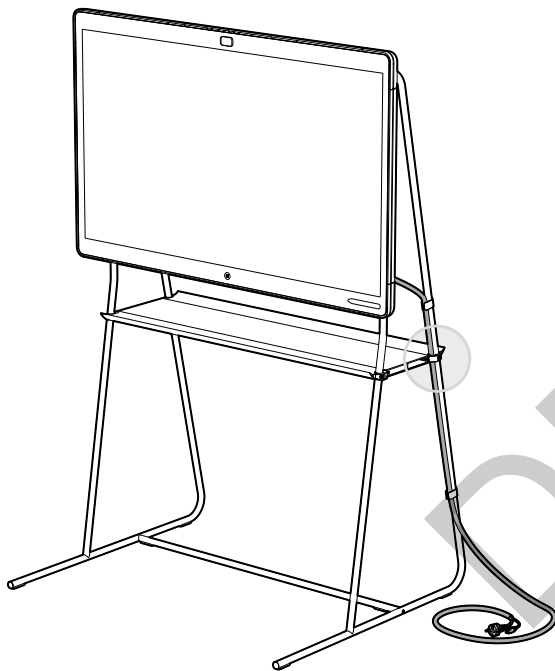
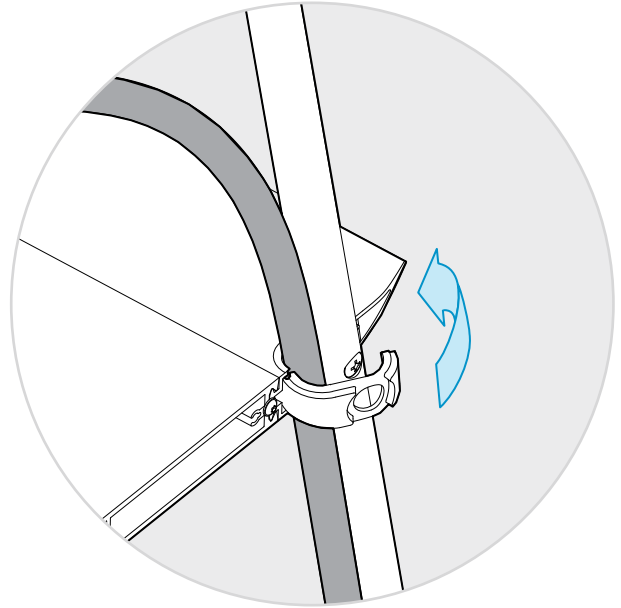

DRAFT

# 11

M6x20 × 4  
PH2 

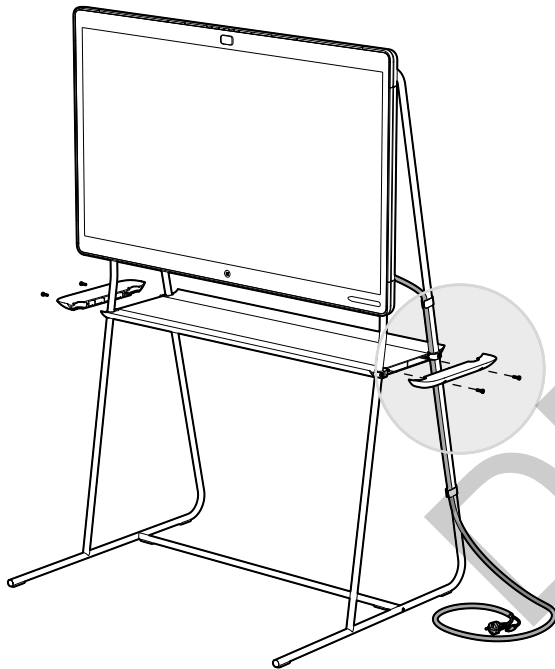
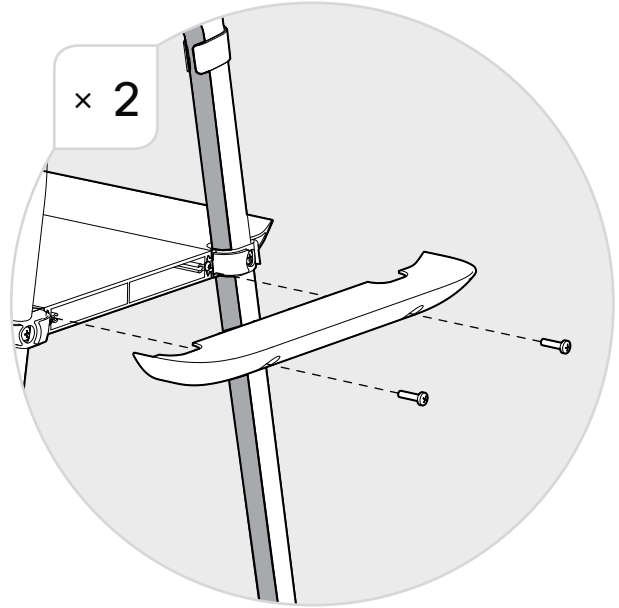



# 12

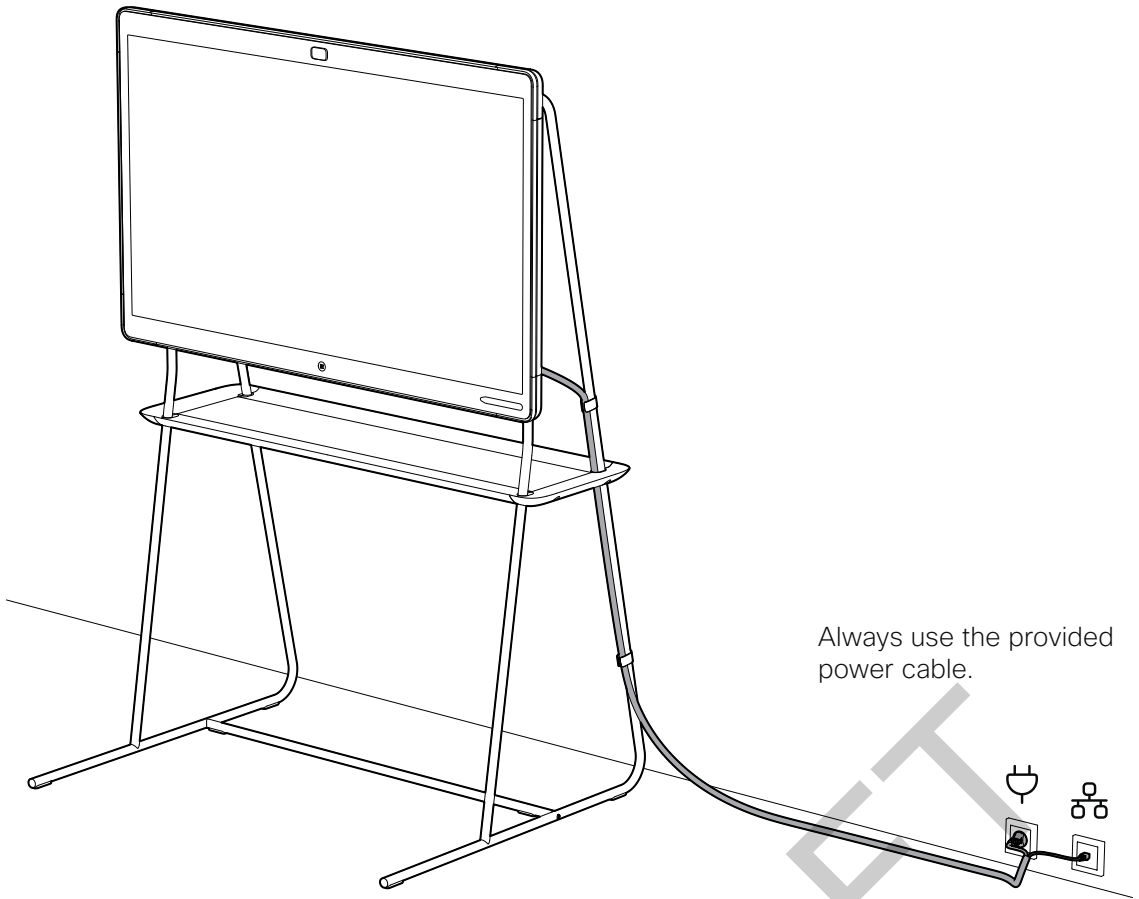

Always use the provided power cable.

Keep the power plug and outlet easily accessible in case you need to disconnect the device from power.



<http://help.ciscopark.com>

Look for Getting Started articles for the product.

# Product overview

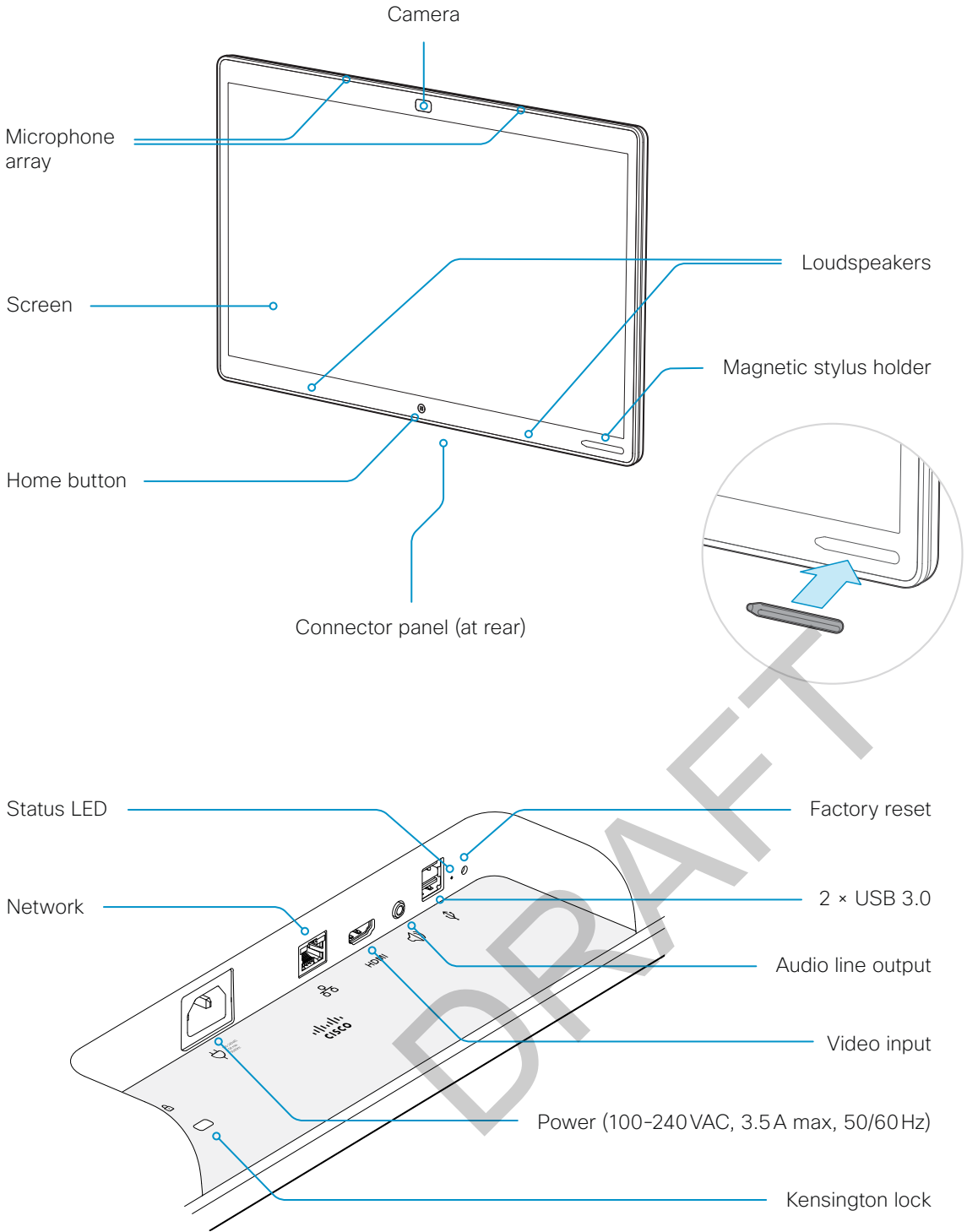

<http://help.ciscopark.com>

Additional support can be found in our on-line documentation.

<http://www.cisco.com/go/projectworkplace>

Explore the Cisco Project Workplace to find inspiration and guidelines when preparing your office or meeting room for video conferencing.

<http://www.cisco.com/go/telepresence/docs>

Regulatory compliance and safety information are available on-line.

DRAFT



---

Cisco Systems Inc.  
Corporate Headquarters  
170 West Tasman Dr.  
San Jose, CA 95134  
USA

Cisco has more than 200 offices worldwide. Find an overview of the offices on the Cisco web site.

<http://www.cisco.com/go/offices>

---

Cisco and the Cisco logo are trademarks or registered trademarks of Cisco and/or its affiliates in the U.S. and other countries. To view a list of Cisco trademarks, go to this URL: [www.cisco.com/go/trademarks](http://www.cisco.com/go/trademarks). Third-party trademarks mentioned are the property of their respective owners. The use of the word partner does not imply a partnership relationship between Cisco and any other company. (1110R)

## Cisco Spark Board 55

Cisco Spark Board provides an extension of the Cisco Spark experience into meeting rooms. It is an ultra high-resolution presentation screen, digital whiteboard and conferencing device, in an all-in-one product. Seamlessly bring all your Spark cloud content onto the Spark Board, continue where you were in the previous meeting and automatically save everything you do back to the cloud, in a tightly integrated workflow.



### Product Specifications

#### Components

Fully integrated unit including:

- Touch display
- Camera
- Microphone array
- Loudspeakers

#### Display

- Edge LED LCD – 55” 4K, 350 nits, 16:9
- Viewing angle: +- 89 (all directions)
- Number of colors: 1.07 billion (10 bit)
- Contrast: 1:4000
- Response time: 5.5 ms

#### Touch

- Capacitive touch
- Protective glass with optical bonding
- Multi touch

## Inputs and output

- HDMI input
- Home button
- Whiteboarding pen
- 3.5 mm mini jack audio out (line-out)
- 2 USB3.0

## Camera overview

- Fixed lens, infinite focus
- F-value: 2.8
- 4K p60
- HFOV: 86°
- VFOV: 55°
- Camera mounted tilted: -25°

## Audio system

- 12-element microphone array (with intelligent beam forming for voice tracking)
- Integrated voice optimized speakers

## Network

- Ethernet (RJ-45) 100/1000 Mbit
- WiFi 802.11 abgn + ac (2.4/5GHz)
- Bluetooth Ready
- IPv4 DHCP/Static
- NTP

## Product compatibility

Cisco Spark Board requires activation and connection to the Cisco Spark Cloud. The Cisco Spark Cloud provides Meeting, Calling and Messaging capabilities.

## Communication with the Cisco Spark Cloud

Cisco Spark Board is connected to the Cisco Spark Cloud service using RESTful APIs. Communication with other Cisco Spark Boards, Cisco Spark Apps or third party solutions is provided through the Cisco Spark Cloud.

## Software

Cisco Spark Board runs Spark Board OS provisioned by the Cisco Spark Cloud. Cisco Spark Board is automatically upgraded and will always run the latest available software.

Communication with the Cisco Spark Cloud is utilizing the H.264 codec for video and OPUS codec for audio.

## Security

For real-time media (voice, video, and screen sharing), we encrypt what is shared using the Secure Real-Time Transport Protocol (SRTP). End-to-end encryption uses AES128, AES256, SHA1, SHA256, and RSA.

## User Interface

- Control Cisco Spark Board directly from the touch screen or using your own device running the Cisco Spark App.

## Language support

- English

## Physical dimensions (H x W x D)

- Cisco Spark Board 55: 50 x 32 x 1.9 in. (814 x 1283 x 49mm)

## Weight

- Cisco Spark Board 55: 87.7 lb. (39,8Kg)

## Physical dimensions and weight of packaging (H x W x D)

### Cisco Spark Board 55 – main unit

- Consolidated package size: 36.2 x 55.7 x 7.5 in. (919 x 1416 x 191 mm)
- Shipping weight: 101 lb. (45.8Kg)

### Cisco Spark Board 55 - Floor Stand Kit

- Consolidated package size: 41.9 x 77,7 x 5.2 in. (1064 x 1974 x 132 mm)
- Shipping weight: 55 lb. (25 Kg)

### Cisco Spark Board 55 – Wall Stand Kit

- Consolidated package size: 30.2 x 48.5 x 4.2 in. (768 x 1231 x 106 mm)
- Shipping weight: 28.6 lb. (13 Kg)

### Cisco Spark Board 55 – Wall Mount Kit

- Consolidated package size: 10 x 54.5 x 2 in. (253 x 1386 x 51 mm)
- Shipping weight: 13.2 lb. (6 Kg)

## Power

- Autosensing power supply
- Power Rating: 100-240 VAC, Max 3.5 A, 50/60 Hz
- Power Consumption: TBC

## Temperature range

- Operating temperature: 0 to 35°C

## Approvals and compliance

- TBC

## Video input:

### 1 x HDMI for local or presentations

Supports formats up to maximum 1920 x 1080 including:

- 640 x 480
- 720 x 480
- 720 x 576
- 800 x 600
- 848 x 480
- 1024 x 768
- 1152 x 864
- 1280 x 720
- 1280 x 1024
- 1280 x 768
- 1280 x 800
- 1280 x 960
- 1360 x 768
- 1366 x 768
- 1400 x 1050
- 1440 x 900
- 1680 x 1050
- 1920 x 1080

Extended Display Identification Data (EDID)

### Live video resolutions (encode/decode) – main video and presentation sharing:

- 176 x 144@30 (QCIF) (Decode only)
- 352 x 288@30 (CIF)
- 512 x 288@30 (w288p)
- 576 x 448@30 (448p)
- 768 x 448@30 (w448p)
- 704 x 576@30 (4CIF)
- 1024 x 576@30 (w576p)
- 640 x 480@30 (VGA)
- 800 x 600@30 (SVGA)
- 1024 x 768@30 (XGA)



- 1280 x 768@30 (WXGA)
- 1280 x 720@30 (HD720p)
- 1920 x 1080@30 (HD1080p)

**Audio features:**

- High-quality 20 kHz stereo audio
- Acoustic echo cancellation
- Automatic Gain Control (AGC)
- Automatic noise reduction
- Active lip synchronization
- Microphone array with intelligent beam forming for voice tracking.

## Ordering Information

**Table 1.** Ordering Information

Product Name	Compliance Model Number	Part Number
Cisco Spark Board 55	AA55WW	SPARK-BOARD55-K9
Cisco Spark Board 55 – Floor Stand Kit		SPARK-BOARD55-FSK
Cisco Spark Board 55 – Wall Stand Kit		SPARK-BOARD55-WSK
Cisco Spark Board 55 – Wall Mount Kit		SPARK-BOARD55-WMK

**Table 2.** Spares

Product Name	Part Number
Cisco Spark Board 55 – Spare	SPARK-BOARD55=
Cisco Spark Board 55 – Floor Stand Kit - Spare	SPARK-BOARD55-FSK=
Cisco Spark Board 55 – Wall Stand Kit – Spare	SPARK-BOARD55-WSK=
Cisco Spark Board 55 – Wall Mount Kit – Spare	SPARK-BOARD55-WMK=
Cisco Spark Board Pen for whiteboarding – 3 pack – spare	SPARK-BOARD-PEN3x=

**Table 3.** Subscription

Product Name	Part Number
Cisco Spark Board - Subscription	A-SPK-ND-BRD

On our web site you will find an overview of the worldwide Cisco contacts.

Go to:  
<http://www.cisco.com/web/siteassets/contacts>

Corporate Headquarters  
Cisco Systems, Inc.  
170 West Tasman Dr.  
San Jose, CA 95134 USA



EU Authorized Representative:  
Edgard Vangeel  
Cisco Systems Belgium  
De Kleetlaan 6A  
B 1831 Diegem  
Belgium

vCisco and the Cisco logo are trademarks or registered trademarks of Cisco and/or its affiliates in the U.S. and other countries. To view a list of Cisco trademarks, go to this URL: [www.cisco.com/go/trademarks](http://www.cisco.com/go/trademarks). Third-party trademarks mentioned are the property of their respective owners. The use of the word partner does not imply a partnership relationship between Cisco and any other company. (1110R)

Cisco et le logo Cisco sont des marques commerciales enregistrées ou non de Cisco Systems, Inc., et/ou de ses filiales aux États-Unis et dans d'autres pays. Pour afficher la liste des marques de commerce de Cisco, visitez le site : [www.cisco.com/go/trademarks](http://www.cisco.com/go/trademarks). Les autres marques mentionnées sont la propriété de leur détenteur respectif. L'utilisation du mot « partenaire » ne signifie aucunement qu'il existe une relation de partenariat entre Cisco et une autre société. (1110R)

Cisco и логотип Cisco являются товарными знаками или зарегистрированными товарными знаками корпорации Cisco и/или ее дочерних компаний в США и других странах. Чтобы просмотреть перечень товарных знаков корпорации Cisco, перейдите по следующему URL-адресу: [www.cisco.com/go/trademarks](http://www.cisco.com/go/trademarks). Товарные знаки сторонних организаций, упомянутые в настоящем документе, являются собственностью соответствующих владельцев. Использование слова «партнер» не подразумевает наличия партнерских взаимоотношений между Cisco и любой другой компанией. (1110R)

**DRAFT - INTERNAL USE ONLY**

### 产品中有毒有害物质或元素的名称及含量

部件名称	有毒有害物质或元素					
	铅	汞	镉	六价铬	多溴联苯	多溴二苯醚
金属部件 (包括紧固件)	<b>X</b>	○	○	○	○	○
印刷电路板组件和元件	<b>X</b>	○	○	○	○	○
线缆和线缆组件	<b>X</b>	○	○	○	○	○
塑料和聚合物部件	○	○	○	○	○	○
显示器, 包含灯泡	<b>X</b>	<b>X</b>	○	○	○	○
除印刷电路板外的其他电子组件	<b>X</b>	○	○	○	○	○
光学玻璃材料	<b>X</b>	○	<b>X</b> (透光玻璃)	○	○	○
干电池	○	○	○	○	○	○

本表格依据 SJ/T 11364 的规定编制。

○: 表示该有毒有害物质在该部件所有均质材料中的含量均在GB/T 26572 规定的限量要求以下。

**X**: 表示该有毒有害物质至少在该部件的某一均质材料中的含量超出GB/T 26572 规定的限量要求。

以销售日期为准, 此表显示在“思科系统公司”的电子信息技术产品中何处存在这些有毒有害物质。请注意, 并非上列所有部件都有包含在内装产品中。

除非产品上另有标记, 所有内附产品及其部件的‘环保使用期限’均由此显示的符号表示。此环保使用期限只适用于产品手册中所规定的使用条件。



## Cisco Spark Board

Compliance Model Number: AA55WW

## Safety Information

## Where to Find Product Documentation

The Cisco Spark Board weighs approximately 40kg/88lb. Do not attempt to lift it out of the box on your own.

Installation of your Cisco Spark Board varies depending on the mounting option you have chosen. You can find the installation instructions in the box for your mounting option.

The information in this document is applicable to the Cisco Spark Board.

<b>Product Information</b>
http://help.ciscopark.com
<b>Warranty Information</b>
http://www.cisco-warrantyfinder.com
<b>Regulatory, Compliance, and Safety Information</b>
http://www.cisco.com/go/telepresence/docs
<b>End User License Agreement and License Information</b>
http://www.cisco.com/go/eula
http://www.cisco.com/go/license

## Antennas

The device has integrated antennas which cannot be replaced.

## Radio Channels

The phones use World Mode (802.11d) to determine operating channels and transmit powers.

## Où trouver la documentation du produit

Cisco Spark Board pèse environ 40kg. N’essayez pas de soulever seul le serveur pour le sortir de la boîte.

Suivez les instructions du guide d’assemblage contenu dans l’emballage avec le support de Cisco Spark Board.

Les informations présentées dans ce document s’appliquent Cisco Spark Board.

<b>Informations sur le produit</b>
http://help.ciscopark.com
<b>Informations sur la garantie</b>
http://www.cisco.com/ca/allergarantie
<b>Informations relatives à la conformité et à la sécurité</b>
http://www.cisco.com/go/telepresence/docs
<b>Contrat de licence de l'utilisateur final et informations sur la licence</b>
http://www.cisco.com/go/eula
http://www.cisco.com/go/license

**Pour consulter les documents en français (y compris les nouveautés), identifiez-vous :**
http://www.cisco.com/cisco/web/CA/fr/support/index.html

## Antennes

L'appareil comprend des antennes intégrées qui ne peuvent être remplacées.

## Canaux radio

Les téléphones utilisent la norme mondiale (802.11d) pour déterminer les canaux en fonctionnement et les puissances d’émission.

## Gде найти документацию по продукту

Вес Cisco Spark Board составляет примерно 40 кг. Не пытайтесь самостоятельно вынуть его из коробки.

Следуйте инструкциям в «Руководстве по сборке», которое поставляется с оборудованием и упаковано с подставкой для Cisco Spark Board.

Информация в данном документе относится к Cisco Spark Board.

<b>Информация о продукте</b>
http://help.ciscopark.com

<b>Информация о гарантии</b>
http://www.cisco-warrantyfinder.com

<b>Информация о безопасности и соблюдении нормативных требований</b>
http://www.cisco.com/go/telepresence/docs

<b>Лицензионное соглашение конечного пользователя и информация о лицензии</b>
http://www.cisco.com/go/eula
http://www.cisco.com/go/license

<b>Дополнительную информацию на русском языке можно получить на сайте</b>
http://www.cisco.ru

### Антенны

Устройство оснащено встроенными антеннами, которые не подлежат замене.

### Радиоканалы

Для определения рабочих каналов и мощности передачи телефоны используют режим World Mode (802.11d).

## 日本語マニュアルのご案内および製品使用における安全上のご注意

シスコ製品の日本語マニュアルは、次のWebページに掲載しております。ご使用前にご参照いただきますようお願いいたします。

http://www.cisco.com/web/JP/techdoc/index.html

また、シスコ製品をご使用になる前に**安全上の注意**をご確認ください。

http://www.cisco.com/web/JP/techdoc/pldoc/pldoc.html

## FCC

**CAUTION:**

**To assure continued FCC compliance:**

Any changes or **modifications** not expressly approved by the grantee of this device could

void the user’s authority to operate the equipment.

### Exposure to Radio Frequency Radiation:

This equipment complies with FCC radiation exposure limits set forth for an uncontrolled environment. This equipment should be installed and operated with minimum distance 20cm between the radiator & your body.

## IC

This device complies with Industry Canada license-exempt RSS standard(s). Operation is subject to the following two conditions: (1) this device may not cause interference, and (2) this device must accept any interference, including interference that may cause undesired operation of the device.

This equipment complies with IC radiation exposure limits set forth for an uncontrolled environment. This equipment should be installed and operated with minimum distance 20cm between the radiator and your body.

5150–5250MHz is limited to use indoor only

### French:

Cet appareil radio est conforme au CNR d’Industrie Canada. L’utilisation de ce dispositif est autorisée seulement aux deux conditions suivantes : (1) il ne doit pas produire de brouillage, et (2) l’utilisateur du dispositif doit être prêt à accepter tout brouillage radioélectrique reçu, même si ce brouillage est susceptible de compromettre le fonctionnement du dispositif.

Cet équipement est conforme aux limites d’exposition aux rayonnements IC établies pour un environnement non contrôlé. Cet équipement doit être installé et utilisé avec un minimum de 20 cm de distance entre la source de rayonnement et votre corps.

5150–5250MHz est limitée à une utilisation en intérieur uniquement.

## Statement of Declaration of Conformity to R&TTE Directive 1999/5/EC for the European Community, Switzerland, Norway, Iceland and Liechtenstein

**English:** This equipment is in compliance with the essential requirements and other relevant provisions of Directive 1999/5/EC.

**Български [Bulgarian]:** Това оборудване отговаря на съществените изисквания и приложими на Директива 1999/5/EC.

**Česky [Czech]:** Toto zařízení je v souladu základními požadavky a ostatními odpovídajícími ustanoveními Směrnice 1999/5/EC.

**Dansk [Danish]:** Dette udstyr er i overensstemmelse med de væsentlige krav og andre relevante bestemmelser i Direktiv 1999/5/EF.

**Deutsch [German]:** Dieses Gerät entspricht den grundlegenden Anforderungen und den weiteren entsprechenden Vorgaben der Richtlinie 1999/5/EU.

**Eesti [Estonian]:** See seade vastab direktiivi 1999/5/EÜ olulistele nõuetele ja teistele asjakohastele sätetele.

**Español [Spanish]:** Este equipo cumple con los requisitos esenciales así como con otras disposiciones de la Directiva 1999/5/CE.

**Ελληνική [Greek]:** Αυτό ο εξοπλισμός είναι σε συμμόρφωση με τις ουσιαστικές και άλλες σχετικές διατάξεις της Οδηγίας 1999/5/ΕC.

**Français [French]:** Cet appareil est conforme aux exigences essentielles et aux autres dispositions pertinentes de la Directive 1999/5/EC.

**Hrvatski [Croatian]:** Ova oprema je u skladnosti s bitnim zahtjevima i drugim relevantnim odredbama Direktive 1999/5/EC.

**Íslenska [Icelandic]:** Þetta tæki er samkvæmt grunnkröfum og öðrum viðeigandi ákvæðum Tilskipunar 1999/5/EC.

**Italiano [Italian]:** Questo apparato è conforme ai requisiti essenziali ed agli altri principi sanciti dalla Direttiva 1999/5/CE.

**Latviski [Latvian]:** Šī iekārta atbilst Direktīvas 1999/5/EK būtiskajām prasībām un citiem ar to saistītajiem noteikumiem.

**Lietuvių [Lithuanian]:** Šis įrenginys tenkina 1999/5/EB Direktyvos esminius reikalavimus ir kitas šios direktyvos nuostatas.

**Nederlands [Dutch]:** Dit apparaat voldoet aan de essentiële eisen en andere van toepassing zijnde bepalingen van de Richtlijn 1999/5/EC.

**Malti [Maltese]:** Dan l-apparat huwa konformi mal-htigiet essenzjali u l-provedimenti l-ohra rilevanti tad-Direttiva 1999/5/EC.

**Magyar [Hungarian]:** Ez a készülék teljesíti az alapvető követelményeket és más 1999/5/EK irányelvben meghatározott vonatkozó rendelkezéseket.

**Norsk [Norwegian]:** Dette utstyret er i samsvar med de grunnleggende krav og andre relevante bestemmelser i EU-direktiv 1999/5/EF.

**Polski [Polish]:** Urządzenie jest zgodne z ogólnymi wymaganiami oraz szczegółowymi warunkami określonymi Dyrektywą UE: 1999/5/EC.

**Português [Portuguese]:** Este equipamento está em conformidade com os requisitos essenciais e outras provisões relevantes da Directiva 1999/5/EC.

**Română [Romanian]:** Acest echipament este în conformitate cu cerințele esențiale și cu alte prevederi relevante ale Directivei 1999/5/EC.

**Slovensko [Slovenian]:** Ta naprava je skladna z bistvenimi zahtevami in ostalimi relevantnimi pogoji Direktive 1999/5/EC.

**Slovensky [Slovak]:** Toto zariadenie je v zhode so základnými požiadavkami a inými príslušnými nariadeniami direktív: 1999/5/EC.

**Suomi [Finnish]:** Tämä laite täyttää direktiivin 1999/5/EC olennaiset vaatimukset ja on

siinä asetettujen muiden laitetta koskevien määräysten mukainen.

**Svenska [Swedish]:** Denne utrustning är i överensstämmelse med de väsentliga kraven och andra relevanta bestämmelser i Direktiv 1999/5/EC.

**Türk [Turkish]:** Bu cihaz 1999/5/EC Direktifi'nin temel gereklerini ve ilgili diğer hükümlerine uygundur.

The full declaration of conformity for this product can be found at:

La déclaration de conformité est disponible dans son intégralité à l'adresse:

Полный текст заявления о соответствии для данного изделия см. в <http://www.ciscofax.com>

Cisco.com login is required to access this document. You can register for a Cisco.com account if you don't have one.

Une connexion à Cisco.com est nécessaire pour accéder à ce document. Si vous ne disposez pas d'un compte Cisco.com, enregistrez vous pour en obtenir un.

Для доступа к этому документу требуются учетные данные Cisco.com. Если у вас нет учетной записи, вам необходимо зарегистрироваться на Cisco.com

## National Restrictions

## Restrictions nationales

## Государственные ограничения

This section identifies countries that have additional requirements or restrictions.

Cette section présente les pays qui imposent des exigences ou des restrictions supplémentaires.

В данном разделе указаны страны, в которых установлены дополнительные требования или ограничения.

### Italy

## Italie

## Италия

This product meets the National Radio Interface and the requirements specified in the National Frequency Allocation Table for Italy. Unless this wireless LAN product is operating within the boundaries of the owner’s property, its use requires a “general authorization.” Please check <http://www.comunicazioni.it/it/> for more details.

Ce produit respecte l’interface radio nationale et les exigences spécifiées dans le tableau d’attribution des fréquences nationales pour l’Italie. À moins que ce produit pour réseau local sans fil fonctionne dans les limites de la propriété de son utilisateur, son utilisation nécessite une « autorisation générale ». Veuillez consulter le site <http://www.comunicazioni.it/it/> pour de plus amples informations.

Данное изделие соответствует национальному радиointерфейсу и требованиям государственной таблицы распределения частот Италии. Если данное изделие для беспроводных локальных сетей работает за пределами частной территории, для его использования требуется «общее разрешение». Более подробная информация приведена на странице <http://www.comunicazioni.it/it/>.

Questo prodotto è conforme alla specifica di Interfaccia Radio Nazionali e rispetta il Piano Nazionale di ripartizione delle frequenze in Italia. Se non viene installato all’interno del proprio fondo, l’utilizzo di prodotti Wireless LAN richiede una “Autorizzazione Generale”. Consultare <http://www.comunicazioni.it/it/> per maggiori dettagli.