

ConnectCore™ 9C/Wi-9C Hardware Reference



Part number/version: 90000789_B
Release date: January 2007
www.digiembedded.com

©2005-2007 Digi International Inc.
Printed in the United States of America. All rights reserved.

Digi, Digi International, the Digi logo, NetSilicon, a Digi International Company, Jump Start Kit, ConnectCore, NET+, NET+OS and NET+Works are trademarks or registered trademarks of Digi International, Inc. in the United States and other countries worldwide. All other trademarks are the property of their respective owners.

Information in this document is subject to change without notice and does not represent a commitment on the part of Digi International.

Digi provides this document "as is," without warranty of any kind, either expressed or implied, including, but not limited to, the implied warranties of, fitness or merchantability for a particular purpose. Digi may make improvements and/or changes in this manual or in the product(s) and/or the program(s) described in this manual at any time.

This product could include technical inaccuracies or typographical errors. Changes are made periodically to the information herein; these changes may be incorporated in new editions of the publication.

Digi International, Inc.
11001 Bren Road East
Minnetonka, MN 55343 U.S.A.
United States: +1 877 912-3444
Other locations: +1 952 912-3444

www.digiembedded.com

Contents

Chapter 1: About the Modules	1
Common module features	1
Wi-9C specific features	2
Memory	2
Memory clocks	2
Other system clocks	2
Interfaces	2
Ethernet	2
WLAN	3
USB 2.0 Host and Device	3
Serial	4
I2C	4
External Memory bus	4
LCD	4
ConnectCore 9C configurations	5
Configuration diagrams	5
ConnectCoreWi-9C configurations	7
Configuration diagrams	7
Chapter 2: What's on the Module?	11
Module layout	11
Ethernet connector	12
Ethernet connector pins	12
Ethernet LEDs	12
802.3af Power over Ethernet (PoE) pass-through connector, P5	13
Connector description	13
PoE support	13
Module LEDs	14
Description	14
ConnectCore Wi-9C default use	14
JTAG 20-pin header connector, P2	15
Pin assignment	15
JTAG adapter assembly	16
JTAG adapter	16

Assembly	17
USB Host connector, P6.....	18
Edge connector, P3.....	18
Pin assignment	18
Pin assignment by SO-DIMM pin number	19
Pin assignment by GPIO.....	24
Antenna connectors: RP/SMA and U.FL (ConnectCore Wi-9C only)	26
RP-SMA connectors, P10 and P8	27
U.FL connectors, P11 and P9	27

Chapter 3: About the Development Board	29
Features.....	29
Basic description.....	30
Switches and buttons	31
Serial Port A switch, SW1.....	31
Serial Port B switch, SW2.....	32
User pushbuttons, SW3 and SW4	32
Power switch, SW5	32
Hardware Reset button, SW6	32
VGA (enable) switch, SW7.....	32
I2C and SPI header connectors	33
I2C header connector, P8	33
SPI header connector, P7.....	34
Serial port connectors	35
Serial port A (EIA-232/422/485) connector, P13.....	35
Serial port B (EIA-232) connector, P9	36
Serial port C header connector, P10.....	37
P10 connector pin assignment	37
Serial port D header connector, P11.....	37
VGA connector / External LCD clock	39
VGA connector, P6	39
External LCD clock, G1	40
Development board SO-DIMM connector, P15	40
Bird's-eye view.....	41
Close-up.....	41
Inserting the module into the SO-DIMM connector	41
Application-specific expansion headers — P16 and P17	43
Peripheral application board header, P16	44
Platform application board header, P17	45
LCD application board header, P18	46
USB Device application header, P32.....	48
P32 pin assignment	48
Digital I/O, P19	49
Power over Ethernet (PoE) connectors.....	50



802.3afPoE connector, P20	51
P30 connector	51
P31 connector	51
Through-hole prototyping (wrap-field) area, P3 and P4	52
Through-hole signal rail, P3	52
Wrap-field area, P4	53
Development board LEDs	54
Power LEDs, CR3 and CR5	54
User LEDs, CR6 and CR7	54
Serial LEDs	54
Current Measurement Option (CMO)	55
How the CMO works	56
Power jack, P12	57
Test points	57
Numbers and description	58
Factory default interface configuration for development board	58

Chapter 4: LCD and USB Configuration	59
LCD displays	59
Control and data pins	59
LCD controller control pins	60
LCD controller data pins	60
Colors and gray shades	60
Sample displays	61
Resolution	61
Refresh frequency	61
Sample applications	61
Default LCD controller	62
Formula	62
Example 1: 18-bit VGA	62
USB configuration	63

Appendix E: Module Specifications	65
Mechanical dimensions	65
ConnectCore	
Wi-9C	65
Environmental information	66
ConnectCore 9C	66
ConnectCore	
Wi-9C	66
Network interface	66
Ethernet	66
WLAN	66
Power requirements	67

ConnectCore 9C	67
ConnectCore	
Wi-9C	67
Power up	67
Real-time clock	67
I2C signals.....	67
USB interface.....	68
USB Host	68
USB Device.....	68
Support	68
USB Host with hub on module	68
No USB on module	68
USB Device only	69
Module reset	69
Module / SO-DIMM signal characteristics	70
I/O class details.....	70
Signal characteristics	70
Electrical characteristics.....	75
Absolute maximum ratings	75
Recommended operating conditions.....	75
Power dissipation	76
DC electrical characteristics.....	76
Inputs.....	76
Outputs.....	76
USB internal PHY DC electrical inputs and outputs	77
USB internal PHY DC electrical inputs.....	77
USB internal PHY DC electrical outputs	77
Antenna information	77
Antenna specifications — 2 dBi Dipole	78
Attributes	78
Dimensions.....	78
Antenna strength (radiation pattern) diagram	79
Antenna specifications — 5 dBi Dipole	80
Attributes	80
Dimensions (in mm)	80
Radiation pattern: H-Plane (2.0 and 5.0 GHz)	81
Radiation pattern: E-plane (2.0 and 5.0 GHz)	82
Antenna specifications — 2 dBi PCB mount.....	82
Attributes	83
Radiation patterns.....	83
FCC RF radiation exposure statement.....	84
Safety statements	84

Appendix F: Dimensions and PCB Layouts 87



Module dimensions.....	87
Overall view	88
Detailed views: Top	88
Detailed views: Side	89
Detailed views: End.....	89
Detailed views: Bottom	89
PCB layout	90
Overall view	90
View with detail.....	90

Appendix G: Certifications 93

FCC Part 15 Class B	93
---------------------------	----

Using this Guide

This guide provides information about the Digi ConnectCore 9C and ConnectCore Wi-9C embedded core modules.

Conventions used in this guide

This table describes the typographic conventions used in this guide:

This convention	Is used for
<i>italic type</i>	Emphasis, new terms, variables, and document titles.
monospaced type	Filenames, pathnames, and code examples.

Digi information

Related documentation

For additional documentation, see the Documentation folder in the NET+OS Start menu.

Documentation updates

Digi occasionally provides documentation updates on the Web site (www.digiembedded.com/support).

Be aware that if you see differences between the documentation you received in your package and the documentation on the Web site, the Web site content is the latest version.

Support

To get help with a question or technical problem with this product, or to make comments and recommendations about our products or documentation, use the contact information listed in this table:

For	Contact information
Technical support	www.digiembedded.com/support United States: +1 877 912-3444 Other locations: +1 952 912-3444

About the Modules

C H A P T E R 1

The ConnectCore 9C and ConnectCore Wi-9C modules are powerful ARM9-based modules in a compact and universal SO-DIMM (Small Outline Dual Inline Memory Module) form factor. The modules provide core processing functionality with integrated wired and wireless network connectivity and a complete set of peripheral options in a footprint-compatible interchangeable SO-DIMM form factor that allows you to optimize your system for either Ethernet, WLAN, or both.

The ConnectCore 9C provides 10/100 Ethernet connectivity only.

The ConnectCore Wi-9C provides both 10/100 Ethernet and 802.11b/g wireless networking capabilities.

All modules are fully compliant with EU directive 2002/95/EC (RoHS).

Common module features

- 32-bit NS9360 high performance RISC processor @ 155 MHz
- Up to 256 MB Flash and 256 MB SDRAM
- Compact SO-DIMM (Small Outline-Dual Inline Memory Module) design
- Low power consumption
- Industrial/extended operating temperature
- 10/100 Mbps Ethernet interface with optional on-board RJ-45 connector
- IEEE802.3af compliant power pass-through (mid-span and end-span)
- Up to four high-speed serial ports – UART and SPI mode configurable
- I²C bus interface
- USB 2.0 Host and Device interfaces
- Optional on-board USB Host connector

- Integrated LCD controller
- Up to eight independent 16-/32-bit programmable timers, counters, or four PWM functions
- Four programmable external interrupts
- Up to 55 shared General Purpose Input/Output (GPIO) ports
 - Up to seven high-current (8mA) pins
- 8-bit wide data/address bus with external chip select
- Processor-powered on-chip Real-Time Clock (RTC)
- Population options available (processor speed, memory, connectors)

Wi-9C specific features

- 802.11b/g WLAN interface
- WEP, WPA, and WPA2/802.11i security standard
- Single or dual-diversity antenna options

Memory

The module's standard memory configuration is 4 MB Flash and 16 MB SDRAM.

Memory clocks

Memory clocks = 77.5 MHz

- Not available for off-DIMM use
- `clk_out[0]` — Not used; turned off by code
- `clk_out[1]` — Connected to `clk_in`
- `clk_out[2]` — Used for one bank of two X16 SDRAMs
- `clk_out[3]` — Not used

Other system clocks

- Source clock is a 29.4912 MHz crystal or spread spectrum oscillator.
- USB uses a 48.000 MHz oscillator
- Ethernet versions have a 25.0000 MHz crystal

Interfaces

The ConnectCore 9C/Wi-9C module supports several system interfaces. This section details the features of these interfaces.

Ethernet

The module provides a 10/100 Mbps Ethernet interface with optional on-board RJ-45 connector and integrated LEDs. On modules not populated with the RJ-45 connector, the Ethernet PHY signals are available on the SO-DIMM edge connector.

- Full-duplex or half-duplex
- Station, broadcast, or multicast address filtering
- 2 kB RX FIFO
- 256-byte TX FIFO with on-chip buffer descriptor ring
- Separate TX and RX DMA channels
- Intelligent receive-side buffer size selection
- Full statistics gathering support
- External CAM filtering support

WLAN

The ConnectCore Wi-9C provides integrated 802.11b/g wireless networking capabilities.

Standard compliance: IEEE 802.11g-2003

Frequency: 2.4 GHz

Data rates: Up to 54 Mbps with fallback

Modulation:

- DBPSK (1 Mbps)
- DQPSK (2 Mbps)
- CCK (5.5, 11 Mbps)
- BPSK (6, 9 Mbps)
- QPSK (12, 18 Mbps)
- 16-QAM (24, 36 Mbps)
- 64-QAM (48, 54 Mbps)

Transmit power: 12 dbm typical

Receive sensitivity: -73 dbm @ 54 Mbps and -87 dbm for 11Mbps

Antenna connectors: U.FL or RP-SMA

Dual-diversity: Available on modules with two U.FL or RP-SMA connectors

USB 2.0 Host and Device

- USB v2.0 full speed (12 Mbps) and low speed (1.5 Mbps)
- Independent OHCI Host and Device ports
- Internal USB PHY
- External USB PHY interface

The module provides a population option for a four-port hub with onboard dual-connector (500mA, 5V only) and full speed/low speed support.

Serial

- Bit rates from 75 bps to 921.6 kbps: asynchronous mode
- Bit rates from 1.2 kbps to 11.25 Mbps: synchronous mode
- UART provides:
 - High performance hardware and software flow control
 - Odd, even, or no parity
 - 5, 6, 7, or 8 bits
 - 1 or 2 stop bits
 - Receive-side character and buffer gap timers
- Four receive-side data match detectors
- Two dedicated DMA channels per module; 8 channels total
- 32 byte TX FIFO and 32 byte RX FIFO per module

I²C

- I²C v.1.0 configurable to master or slave
- Bit rates: fast (400 kHz) or normal (100 kHz) with clock stretching
- 7-bit and 10-bit address modes
- Supports I²C bus arbitration

External Memory bus

- 8-bit address bus
- 8-bit data bus
- 1 external chip select

Note: The memory bus on the edge connector (P3) is available only on the ConnectCore Wi-9C module.

LCD

- Dual 64-deep, 32-bit wide FIFOs for buffering incoming display data
- Support for color and monochrome single- and dual-panel for Super Twisted Nematic (STN) displays with 4- or 8-bit interfaces
- Support for Thin Film Transistor (TFT) color displays
- Resolution up to 800 x 600 pixels
- 15 gray-level mono, 3375 color STN, and 64K color TFT support
 - Patented gray-scale algorithm
- 1, 2, or 4 bits-per-pixel (bpp) palettized displays for mono STN
- 1, 2, 4, or 8 bpp palettized color displays for STN and TFT
- 16 bpp true-color non-palettized, for color STN and TFT
- Programmable timing for different display panels
- 256 entry, 16-bit palette RAM, arranged as a 128 x 32-bit RAM

- Frame, line, and pixel clock signals
- AC bias signal for STN, data enable signal for TFT panels
- Support for multiple data formats

ConnectCore 9C configurations

The ConnectCore 9C module is available in these base configurations:

- **Fully populated.** A fully populated module includes on-board Ethernet PHY, Ethernet magnetics with RJ-45, a USB hub and Type A female connector.
- **With Ethernet but no USB Host.** With this setup, Ethernet PHY or Ethernet magnetics with RJ-45 are on the module. The module does not have an on-board USB hub and Type A female connector, although USB Host and Device signals are available on the edge connector.
- **No additional on-board connectors.** With this setup, there is no Ethernet RJ-45 with integrated magnetics on the module.

Note: Modules without an on-board Ethernet connector provide the Ethernet PHY signals through the SO-DIMM edge connector (see “Edge connector, P3” on page 18).

Additional population options are available. For information, contact your local Digi sales office or distributor.

Configuration diagrams

The diagrams in this section show configurations for the ConnectCore 9C module, illustrated with top and edge views.

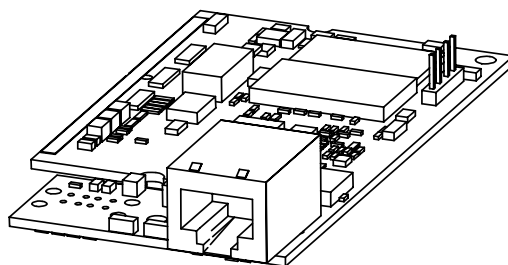

Standard configuration
With Ethernet
Without USB

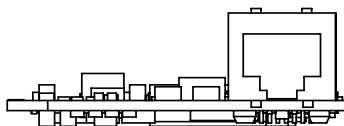

ABOUT THE MODULES
ConnectCore 9C configurations

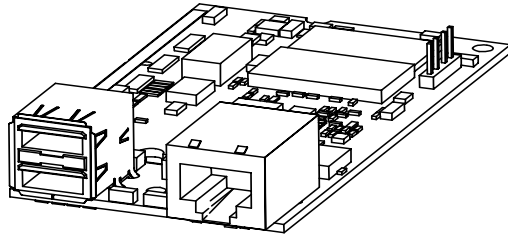

With Ethernet
With USB

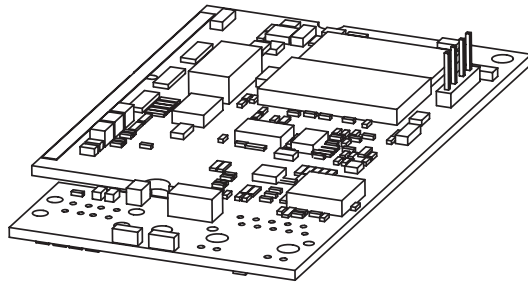
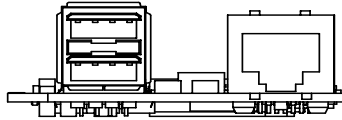

Without Ethernet
Without USB

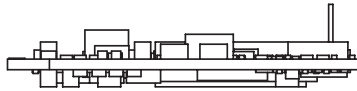

ConnectCoreWi-9C configurations

The ConnectCore Wi-9C module is available in these base configurations:

- **Fully populated, 2xRP-SMA.** A fully populated module using RP-SMA includes on-board Ethernet PHY, Ethernet magnetics with RJ-45, a USB hub and Type A female connector, and two RP-SMA connectors.
- **With Ethernet, without USB, and with single RP-SMA.** With this setup, Ethernet PHY or Ethernet magnetics with RJ-45 are on the module. The module does not have an on-board USB hub and Type A female connector, although USB Host and Device signals are available on the edge connector. There is one RP-SMA connector.
- **No additional on-board connectors, with single RP-SMA.** With this setup, there is no Ethernet RJ-45 with integrated magnetics on the module. There is one RP-SMA connector.
Note: Modules without an on-board Ethernet connector provide the Ethernet PHY signals through the SO-DIMM edge connector (see “Edge connector, P3” on page 18).
- **With Ethernet, without USB, and with 2xU.FL.** With this setup, Ethernet PHY or Ethernet magnetics with RJ-45 are on the module. The module does not have an on-board USB hub and Type A female connector, although USB Host and Device signals are available on the edge connector. There are two U.FL connectors.

Additional population options are available. For information, contact your local Digi sales office or distributor.

Configuration diagrams

The diagrams in this section show configurations for the ConnectCore Wi-9C module, illustrated with top and edge views.

ABOUT THE MODULES

ConnectCoreWi-9C configurations

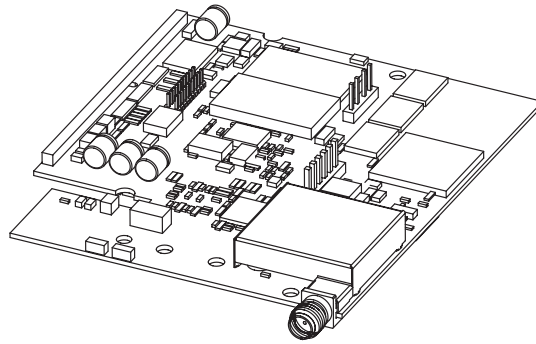

Standard configuration
Without Ethernet
Without USB
With 1xRP-SMA connector

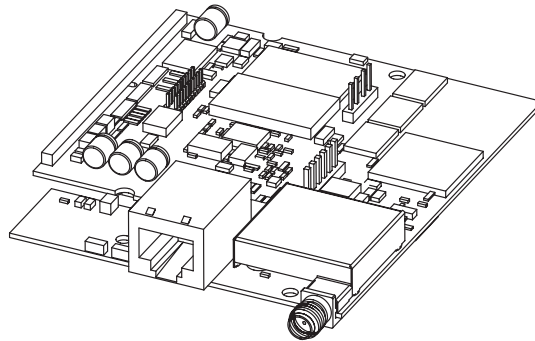

With Ethernet
Without USB
With 1xRP-SMA connector

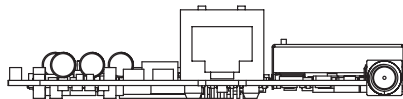

ABOUT THE MODULES
ConnectCoreWi-9C configurations

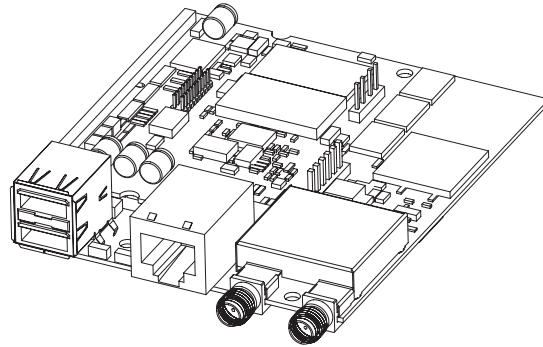

Fully populated
With Ethernet
With USB
With 2xRP-SMA connectors

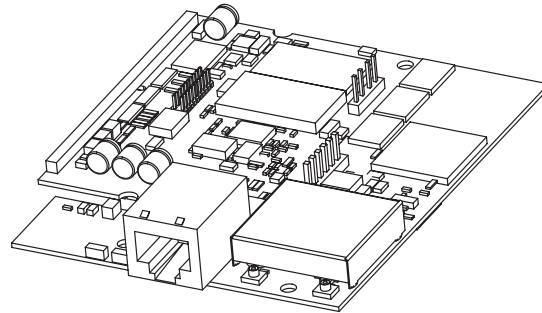
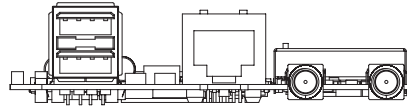

With Ethernet
Without USB
With 2xU.FL connectors

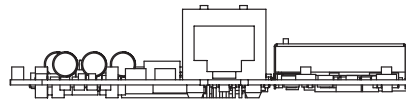

What's on the Module?

CHAPTER 2

This chapter describes the ConnectCore 9C/Wi-9C modules. See Appendix A, "" for the mechanical specifications and electrical characteristics of the modules.

Module layout

The module design you use depends on whether you want to use the ConnectCore Wi-9C wireless capabilities. The basic footprint for the ConnectCore 9C and ConnectCore Wi-9C is the same; an extension of the footprint provides the active components and antenna connectors for wireless functionality.

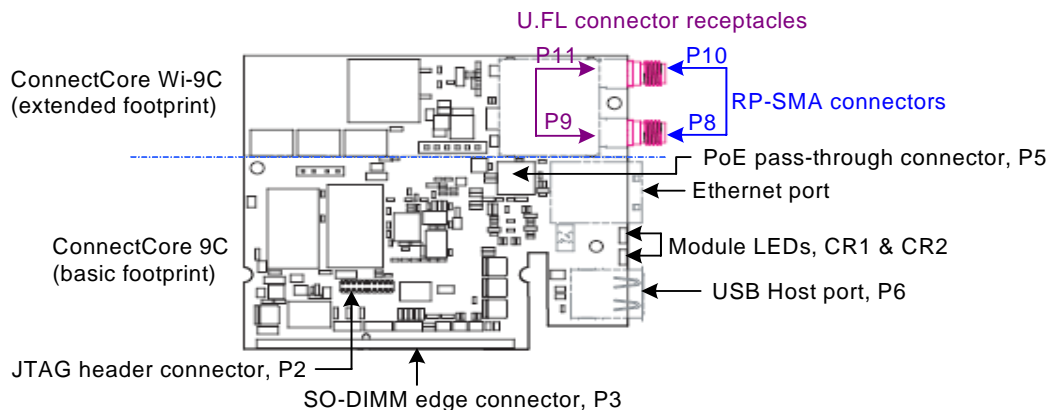

Note: The ConnectCore Wi-9C module is populated with either one RP-SMA connector, two RP-SMA connectors, or 2 U.FL connectors (see "ConnectCoreWi-9C configurations" on page 7 for all module configuration

options). The U.FL connectors are located in the same positions as the RP-SMA connectors, but do not extend past the edge of the module.

Ethernet connector

The Ethernet connector is an 8-wire RJ-45 jack with integrated magnetics that meets the ISO 8877 requirements for 10/100BASE-T. The connector provides both Ethernet interface pins (in the upper portion) and two integrated LEDs (in the lower portion).



Ethernet connector pins

There are eight Ethernet connector pins in the upper portion of the connector. Pin 1 is in the upper left corner of the connector, above the yellow LED. Pins 4, 5, 7, and 8 are used with Power-over-Ethernet (PoE) only (see “802.3af Power over Ethernet (PoE) pass-through connector, P5” on page 13).

Pin	Signal	802.3af End-Span (Mode A)	802.3af Mid-Span (Mode B)	Description
1	TXD+	Negative V_{Port}		Transmit data +
2	TXD-	Negative V_{Port}		Transmit data -
3	RXD+	Positive V_{Port}		Receive data +
4	EPWR+		Positive V_{Port}	Power from switch +
5	EPWR+		Positive V_{Port}	Power from switch +
6	RXD-	Positive V_{Port}		Receive data -
7	EPWR-		Negative V_{Port}	Power from switch -
8	EPWR-		Negative V_{Port}	Power from switch -

Ethernet LEDs

The RJ-45 connector has two LEDs located near the outer lower corners of the Ethernet port. These LEDs are controlled by the Ethernet PHY on the module, and are not programmable.

LED	Description
Green	Network link: On indicates an active network link; Off indicates that no network link is present.
Yellow	Network activity: Flashing when network traffic detected; Off when no network traffic detected.

802.3af Power over Ethernet (PoE) pass-through connector, P5

The PoE pass-through connector, P5, mates with the P20 header on the development board. This PoE pass-through feature passes PoE power connections from the Ethernet signal cable to the user's equipment through P5. The PoE feature provides a power source for compliant "powered" equipment, and is nominally 48VDC with a possible 30-57VDC 13 W maximum range.



Connector description

Pin	Signal	Description
1	TX_CT	Ethernet transformer transmit CT
2	RJ45_7/8	Ethernet connector pins 7 and 8
3	RX_CT	Ethernet transformer receive CT
4	RJ45_4/5	Ethernet connector pins 4 and 5

PoE support

If you are planning to add PoE support to your product, see the most recent revision of the IEEE 802.3af specification available at <http://www.ieee802.org/3/af/>. The document provides detailed information about the standard and its proper implementation.

Module LEDs

By default, the ConnectCore 9C/Wi-9C modules use the CR1 and CR2 LEDs as described:

- **ConnectCore Wi-9C module:** To indicate WLAN-related information, such as association status and network activity.
- **ConnectCore 9C and Wi-9C modules:** CR1 will flash a repeating blink pattern in a major system failure; for example, a processor exception or Power on Self Test failure.

The ConnectCore Wi-9C LED assignments can be reassigned; that is, you can use different GPIOs to drive CR1/CR2 LEDs.

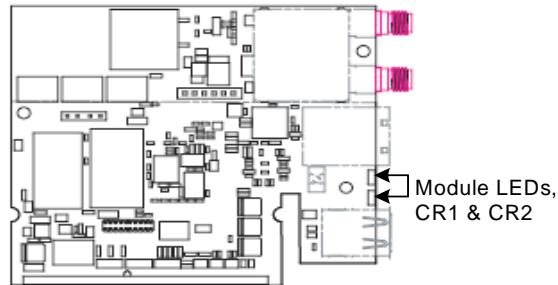

Description

ID	Connects to	Default	Description
CR1	GPIO67	Off	Setting to output logic "0" turns on the LED.
CR2	GPIO66	Off	Setting to output logic "0" turns on the LED.

ConnectCore Wi-9C default use

ID	Color	LED	Blink pattern	Status / Activity
CR1	Green	Link integrity	On	The unit is associated to an access point (infrastructure mode)
			Slow	The unit is in ad-hoc mode
			Quick	The unit is scanning for a network
CR2	Yellow	Network activity	Blinking	Network traffic is received or transmitted
			Off	Network is idle

Note: The network activity LED is used for diagnostic purposes during boot-up.

JTAG 20-pin header connector, P2

The JTAG connector is a standard, male, ARM 20-pin pinout in a miniature connector, with a 50-mil pitch. A JTAG adapter, which ships with each Jump Start kit, expands the JTAG connector to a 100 mil pitch. Use the included JTAG adapter to connect the debugger.

The JTAG connector on the module is *keyed*, as are the two connectors on the JTAG adapter, which means there is only one way to attach ribbon cables to the module and JTAG adapter. For details, see “JTAG adapter assembly” on page 16.

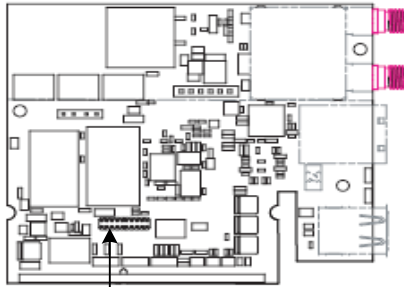

JTAG header connector, P2

Pin assignment

Pin	Signal	Description
1	3.3V	ARM9 I/O supply
2	3.3V	ARM9 I/O supply
3	TRST#	Test mode reset
4	GND	Ground
5	TDI	Test data in
6	GND	Ground
7	TMS	Test mode select
8	GND	Ground
9	TCK	Test clock
10	GND	Ground
11	RTCK	Returned test clock (ARM core only)
12	GND	Ground
13	TDO	Test data out
14	GND	Ground
15	DBSRST#	System reset
16	GND	Ground

Pin	Signal	Description
17	N/A	N/A
18	GND	Ground
19	BISTEN#	ARM9 mode select: <ul style="list-style-type: none"> ■ Debug = Pull high: 220 ohms to pin 2 (3.3V) ■ Boundary scan / normal = Pull low: 220 ohms to pin 20 (GND)
20	GND	Ground

JTAG adapter assembly

Use the JTAG adapter assembly, shipped with the ConnectCore 9C/Wi-9C Jump Start Kit, to attach your debugger to the module. The JTAG adapter assembly consists of the Digi JTAG Link USB debugger with a ribbon cable attached and the JTAG adapter with a ribbon cable attached. The Jump Start Kit also includes a USB cable.

The two connectors on the JTAG adapter are *keyed*, as is the JTAG connector header (P2) on the module. Keyed connectors eliminate cable attachment errors by ensuring that there is only one way to mate the connectors.

JTAG adapter

The JTAG adapter has two 20-pin connectors, P1 and P2.

- **P1** is a keyed male connector into which you attach the debugger's ribbon cable.
- **P2** is a keyed male connector into which you attach the ribbon cable that plugs into the module.
- **J1** is a jumper that determines the mode in which the module operates: debug or boundary scan. Depending on the JTAG adaptor you are using, J1 has either two pins or three pins.

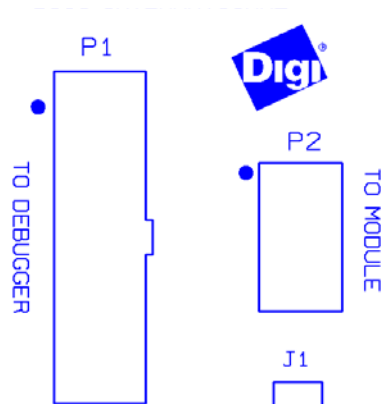

This drawing shows the JTAG adapter with a 2-pin J1 header.

For **debug** mode — Do not plug a jumper onto J1.

For **boundary scan** mode — Plug a jumper onto J1.

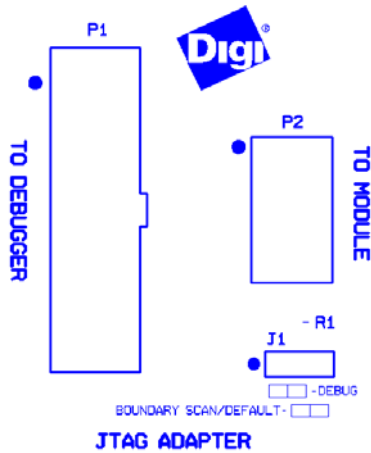

This drawing shows the JTAG adapter with a 3-pin J1 header. The pin positions for debug and boundary scan are shown in the lower right of the drawing:

For debug mode – Plug a jumper on pins 1 and 2.

For boundary scan mode (the default) – Plug a jumper on pins 2 and 3.

Assembly

- 1 Plug the debugger ribbon cable into the connector labeled P1 on the JTAG adapter.
- 2 Plug the adapter ribbon cable (attached to P2 on the adapter) into the P2 connector on the module.

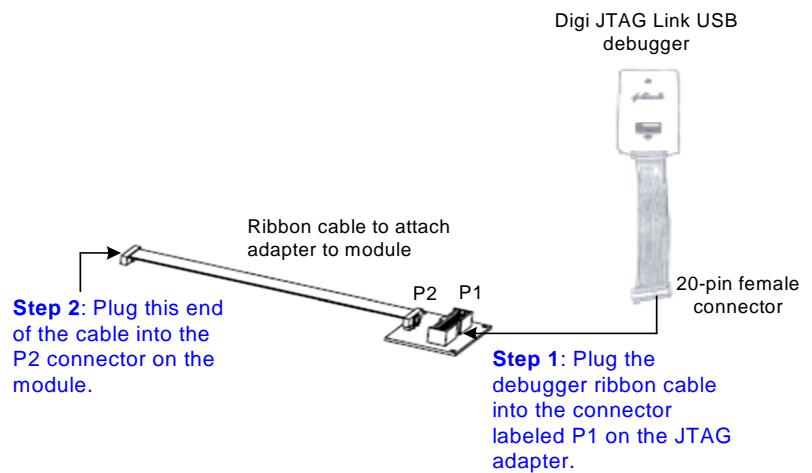

USB Host connector, P6

When populated, the USB Host connector is on the same side of the module as the Ethernet connector, separated from the Ethernet connector by CR1 and CR2.

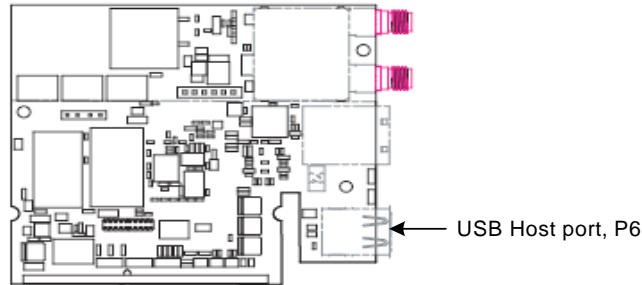

See "USB interface" on page 68 for information about the USB interface.

Edge connector, P3

The edge connector is a 144-pin SO-DIMM connector located on the short edge of the module. P3 mates with P15 (also a 144-position SO-DIMM connector) on the development board or an SO-DIMM connector on your design.

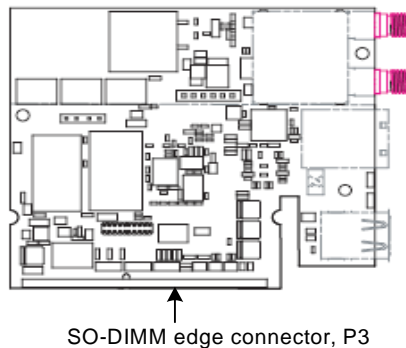

Note: The clearance underneath the module and development board should be 2.54mm (0.10").

Pin assignment

The next tables show information for all pins on the edge connector, in DIMM pin order. For additional SO-DIMM pin characteristics, see "Module / SO-DIMM signal characteristics," beginning on page 70.

- Some signals are multiplexed to two different GPIO pins, to maximize the number of possible applications. The primary/duplicate signals are noted in

the Notes column in the table. Using the primary GPIO pin and the duplicate pin for the same function is not recommended.

Note: Functions in parentheses are duplicates; for example, pin 63 has two entries in the LCD column: CLD6 and (CLD10). CLD10 is a duplicate signal for pin 63; the Notes column identifies the primary function for that signal.

- A # next to a signal indicates that this signal is active low.
- A **bold** value in the System / Other / Bootstrap column indicates the bootstrap signal.

Pin assignment by SO-DIMM pin number

Dimm Pin	Signal	BootStrap (BS) / System / Other	UART	SPI	I2C	USB	LCD	IEEE 1284	PWM / Timer / IRQ	Notes
1	GND									Common GND return
2	GND									Common GND return
3	+3.3V									Power to module
4	+3.3V									Power to module
5	+3.3V									Power to module
6	+3.3V									Power to module
7	WAKEUP# PWRDWN#	System								Wi-9C: WAKEUP# / Reserved CC9C: PWRDWN# / Reserved
8	BUFFENR#	System								Use to isolate bootstrap GPIOs from external loading
9	DATA_0	Data bus								Wi-9C only CC9C: Reserved
10	DATA_1	Data bus								Wi-9C only CC9C: Reserved
11	DATA_2	Data bus								Wi-9C only CC9C: Reserved
12	DATA_3	Data bus								Wi-9C only CC9C: Reserved
13	DATA_4	Data bus								Wi-9C only CC9C: Reserved
14	DATA_5	Data bus								Wi-9C only CC9C: Reserved
15	DATA_6	Data bus								Wi-9C only CC9C: Reserved
16	DATA_7	Data bus								Wi-9C only CC9C: Reserved
17	ADDRESS_0	Address bus								Wi-9C only CC9C: Reserved
18	ADDRESS_1	Address bus								Wi-9C only CC9C: Reserved

Dimm Pin	Signal	BootStrap (BS) / System / Other	UART	SPI	I2C	USB	LCD	IEEE 1284	PWM / Timer / IRQ	Notes
19	GND									Common GND return
20	GND									Common GND return
21	ADDRESS_2	Address bus								Wi-9C only CC9C: Reserved
22	MFGI_ GPIO[72]									Reserved
23	ADDRESS_3	Address bus								Wi-9C only CC9C: Reserved
24	GPIO[71]				iic_sda					GPIO[71]: Output drive 8mA iic_sda: Primary on GPIO[35]
25	ADDRESS_4	Address bus								Wi-9C only CC9C: Reserved
26	GPIO[70]				iic_scl					GPIO[70]: Output drive 8mA iic_scl: Primary on GPIO[34]
27	ADDRESS_5	Address bus								Wi-9C only CC9C: Reserved
28	GPIO[69]								IRQ1	GPIO[69]: Output drive 8mA IRQ1: Primary on GPIO[07] Add 10-15K pullup if not used
29	GND									Common GND return
30	GND									Common GND return
31	GPIO[27]		DCD_D	ENBL_D			CLD3		TIMER4	
32	No connect									
33	GPIO[26]		RI_D	CLK_D			CLD2		TIMER3	
34	GPIO[67]									CR1: Green user LED Output drive 8mA MFGO_CR1
35	GPIO[25]		DSR_D				CLD1			
36	GPIO[66]									CR2: Yellow user LED Output drive 8mA
37	GPIO[24]	BS: CSI_MSB	DTR_D				CLD0			
38	GPIO[23]		DCD_C	ENBL_C			CLLE			
39	GND									Common GND return
40	GND									Common GND return
41	GPIO[47]		CTS_D			RXD-		PINIT#		RXD-: Only used for unidirectional PHY
42	GPIO[22]		RI_C	CLK_C			CLAC			
43	GPIO[46]		RTS_D			RXD+		PAFD#		RXD+: Only used for unidirectional PHY
44	GPIO[21]		DSR_C				CLFP VSYNC			
45	GPIO[45]		RXD_D	DIN_D		RCV		PSTB#		

Dimm Pin	Signal	BootStrap (BS) / System / Other	UART	SPI	I2C	USB	LCD	IEEE 1284	PWM / Timer / IRQ	Notes
46	GPIO[20]	BS: CS1_LSB	DTR_C				CLCP/LDC CLKO			GPIO[20]: Output drive 8mA
47	GPIO[44]	BS: Endian Pull down for Big Endian	TXD_D	DOUT_D		OE		PSELO		
48	GPIO[43]		CTS_C			DATA-		PDIR		Add 10-15K pullup if not used
49	GND									Common GND return
50	GND									Common GND return
51	GPIO[38]						CLD14	PD7	PWM2	PWM2: Duplicate on GPIO[13]
52	GPIO[42]		RTS_C			DATA+				Add 10-15K pullup if not used
53	GPIO[36]						CLD12	PD5	PWM0	PWM0: Duplicate on GPIO[10]
54	GPIO[41]		RXD_C	DIN_C			CLD17			
55	GPIO[34]				SCL		CLD10	PD3		SCL: Duplicate on GPIO[70] CLD10: Duplicate on GPIO[30]
56	GPIO[40]		TXD_C	DOUT_C			CLD16		IRQ3	IRQ3: Duplicate on GPIO[18]
57	GPIO[32]						CLD8	PD1	IRQ2	CLD8: Duplicate on GPIO[28] IRQ2: Duplicate on GPIO[11]
58	GPIO[39]						CLD15	PD8	PWM3	PWM3: Duplicate on GPIO[14]
59	GND									Common GND return
60	GND									Common GND return
61	GND									Common GND return
62	GND									Common GND return
63	GPIO[30]						CLD6 (CLD10)		TIMER6	CLD10: Primary on GPIO[34]
64	GPIO[37]						CLD13	PD6	PWM1	PWM1: Duplicate on GPIO[12]
65	GPIO[28]						CLD4 (CLD8)		IRQ1	CLD8: Primary on GPIO[32] IRQ1: Primary on GPIO[07]
66	GPIO[35]				SDA		CLD11	PD4		SDA: Duplicate on GPIO[71] CLD11: Primary on GPIO[13]
67	GPIO[15]		DCD_A	ENBL_A			LCDCLKI		TIMER2	
68	GPIO[33]						CLD9	PD2		CLD9: Duplicate on GPIO[29]
69	GPIO[14]		RL_A	CLK_A					PWM3 TIMER1	PWM3: Primary on GPIO[39] TIMER1: Duplicate on GPIO[00]
70	GPIO[31]						CLD7 (CLD11)		TIMER7	CLD11: Primary on GPIO[35] TIMER7: Duplicate on GPIO[06]
71	GND									Common GND return
72	GND									Common GND return
73	GPIO[13]		DSR_A						PWM2 IRQ0	PWM2: Primary on GPIO[38] IRQ0: Primary on GPIO[01]
74	GPIO[29]						CLD5 (CLD9)		TIMER5	CLD9: Primary on GPIO[33]
75	GPIO[12]	BS: ND3	DTR_A						PWM1	PWM1: Primary on GPIO[37]

Dimm Pin	Signal	BootStrap (BS) / System / Other	UART	SPI	I2C	USB	LCD	IEEE 1284	PWM / Timer / IRQ	Notes
76	GPIO[07]		DCD_B	ENBL_B					IRQ1	IRQ1: Duplicate on GPIO[28] and GPIO[65]
77	GPIO[11]		CTS_A						TIMER0 IRQ2	TIMER0: Primary on GPIO[02] IRQ2: Primary on GPIO[32]
78	GPIO[06]		RI_B	CLK_B				PFAULT#	TIMER7	PFAULT: Primary on GPIO[16] TIMER7: Primary on GPIO[31]
79	GPIO[10]	BS: ND2	RTS_A						PWM0	PWM0: Primary on GPIO[36]
80	GPIO[05]		DSR_B					PERR		
81	GND									Common GND return
82	GND									Common GND return
83	GPIO[09]		RXD_A	DIN_A						
84	GPIO[04]	BS: ND0	DTR_B					PBUSY		
85	GPIO[08]	BS: ND1	TXD_A	DOUT_A						
86	GPIO[03]		CTS_B					PACK#		
87	GPIO[19]	BS: PLL_BYP					CLLP/ HSYNC			PLL_BYP: Reserved. Do not pull down
88	GPIO[02]	BS: FS1	RTS_B						TIMER0	TIMER0: Duplicate on GPIO[11]
89	GPIO[18]						CLPOWER		IRQ3	IRQ3: Primary on GPIO[40]
90	GPIO[01]		RXD_B	DIN_B					IRQ0	IRQ0: Duplicate on GPIO[13] and GPIO[68]
91	OE#	Output enable								Wi-9C only CC9C: Reserved
92	GPIO[00]	BS: FS0	TXD_B	DOUT_B					TIMER1	TIMER1: Primary on GPIO[14]
93	GND									Common GND return
94	GND									Common GND return
95	WE#	Write enable								Wi-9C only CC9C: Reserved
96	GPIO[49]	BS: CS_POL				SPD		PLH		
97	CS#	Chip select								Wi-9C only CC9C: Reserved
98	GPIO[48]					SUSP		PSELI		
99	TXB+R	Ethernet								Reserved
100	TXA+R	Ethernet								Reserved
101	GND									Common GND return
102	GND									Common GND return
103	TXB-R	Ethernet								Reserved
104	TXA-R	Ethernet								Reserved
105	RST#	System								Hardware reset (input; active LOW; minimum pulse width 10uS)
106	ACT_LED#	Ethernet								Reserved
107	BOOTMUXR#	System								Reserved

WHAT'S ON THE MODULE?

Edge connector, P3

Dimm Pin	Signal	BootStrap (BS) / System / Other	UART	SPI	I2C	USB	LCD	IEEE 1284	PWM / Timer / IRQ	Notes
108	LNK_LED	Ethernet								Wi-9C only CC9C: Reserved
109	GPIO[16]					OVRH#		PFAULT#	PWM0	OVRH#: USB overcurrent input. Available as GPIO on modules with USB hub or Ethernet only. Not available as GPIO if an external Host USB port is implemented using DM1 and DP1. PFAULT#: Primary on GPIO[06] PWM0: Duplicate on GPIO[10]
110	ADDRESS_6	Address bus								Wi-9C only CC9C: Reserved
111	GPIO[17]	ND4				PONH#				PONH#: USB power on output. Available as GPIO on modules with USB hub or Ethernet only. Not available as GPIO if an external Host USB port is implemented using DM1 and DP1.
112	ADDRESS_7	Address bus								Wi-9C only CC9C: Reserved
113	OVR3#									USB port 3 overcurrent Reserved for future use; no connect
114	OVR4#									USB port 4 overcurrent Reserved for future use; no connect
115	PON3#									USB port 3 power-on Reserved for future use; no connect
116	PON4#									USB port 4 power-on Reserved for future use; no connect
117	OVR1#									USB port 1 overcurrent Reserved for future use; no connect
118	OVR2#									USB port 2 overcurrent Reserved for future use; no connect
119	PON1#									USB port 1 power-on Reserved for future use; no connect
120	PON2#									USB port 2 power-on Reserved for future use; no connect
121	GND									Common GND return
122	GND									Common GND return
123	DM4									USB port 4 data (-) Reserved for future use; no connect
124	DP4									USB port 4 data (+) Reserved for future use; no connect
125	GND									Common GND return
126	GND									Common GND return
127	DM3									USB port 3 data (-) Reserved for future use; no connect
128	DP3									USB port 3 data (+) Reserved for future use; no connect
129	GND									Common GND return

Dimm Pin	Signal	BootStrap (BS) / System / Other	UART	SPI	I2C	USB	LCD	IEEE 1284	PWM / Timer / IRQ	Notes
130	GND									Common GND return
131	DM2									USB port 2 data (-) Reserved for future use; no connect
132	DP2									USB port 2 data (+) Reserved for future use; no connect
133	GND									Common GND return
134	GND									Common GND return
135	DM1									USB port 1 data (-) Reserved for future use; no connect
136	DP1									USB port 1 data (+) Reserved for future use; no connect
137	GND									Common GND return
138	GND									Common GND return
139	+5V									Power to USB, if used (Used only with a module with on-board USB)
140	+5V									Power to USB, if used (Used only with a module with on-board USB)
141	+5V									Power to USB, if used (Used only with a module with on-board USB)
142	+5V									Power to USB, if used (Used only with a module with on-board USB)
143	GND									Common GND return
144	GND									Common GND return

Pin assignment by GPIO

Signal	SO-DIMM	BootStrap (BS) / System / Other	UART	SPI	I2C	USB	LCD	IEEE 1284	PWM / Timer / IRQ	Notes
GPIO[00]	92	BS: FS0	TXD_B	DOUT_B					TIMER1	TIMER1: Primary on GPIO[14]
GPIO[01]	90		RXD_B	DIN_B					IRQ0	IRQ0: Duplicate on GPIO[13] and GPIO[68]
GPIO[02]	88	BS: FS1	RTS_B						TIMER0	TIMER0: Duplicate on GPIO[11]
GPIO[03]	86		CTS_B					PACK#		
GPIO[04]	84	BS: ND0	DTR_B					PBUSY		
GPIO[05]	80		DSR_B					PERR		
GPIO[06]	78		RI_B	CLK_B				PFAULT#	TIMER7	PFAULT: Primary on GPIO[16] TIMER7: Primary on GPIO[31]
GPIO[07]	76		DCD_B	ENBL_B					IRQ1	IRQ1: Duplicate on GPIO[28] and GPIO[65]
GPIO[08]	85	BS: ND1	TXD_A	DOUT_A						
GPIO[09]	83		RXD_A	DIN_A						

Signal	SO-DIMM	BootStrap (BS / System / Other)	UART	SPI	I2C	USB	LCD	IEEE 1284	PWM / Timer / IRQ	Notes
GPIO[10]	79	BS: ND2	RTS_A						PWM0	PWM0: Primary on GPIO[36]
GPIO[11]	77		CTS_A						TIMER0 IRQ2	TIMER0: Primary on GPIO[02] IRQ2: Primary on GPIO[32]
GPIO[12]	75	BS: ND3	DTR_A						PWM1	PWM1: Primary on GPIO[37]
GPIO[13]	73		DSR_A						PWM2 IRQ0	PWM2: Primary on GPIO[38] IRQ0: Primary on GPIO[01]
GPIO[14]	69		RI_A	CLK_A					PWM3 TIMER1	PWM3: Primary on GPIO[39] TIMER1: Duplicate on GPIO[00]
GPIO[15]	67		DCD_A	ENBL_A			LCDCLKI		TIMER2	
GPIO[16]	109					OVRH#		PFAULT#	PWM0	OVRH#: USB overcurrent input. Available as GPIO on modules with USB hub or Ethernet only, and not required for external USB Host support. PFAULT#: Primary on GPIO[06] PWM0: Duplicate on GPIO[10]
GPIO[17]	111	ND4				PONH#				PONH#: USB power on output. Available as GPIO on modules with USB hub or Ethernet only, and not required for external USB Host support.
GPIO[18]	89						CLPOWER		IRQ3	IRQ3: Primary on GPIO[40]
GPIO[19]	87	BS: PLL_BYP					CLLP/HSY NC			PLL_BYP: Reserved. Do not pull down
GPIO[20]	46	BS: CS1_LSB	DTR_C				CLCP/LDC CLKO			GPIO[20]: Output drive 8mA
GPIO[21]	44		DSR_C				CLFP VSYNC			
GPIO[22]	42		RI_C	CLK_C			CLAC			
GPIO[23]	38		DCD_C	ENBL_C			CLLE			
GPIO[24]	37	BS: CS1_MSB	DTR_D				CLD0			
GPIO[25]	35		DSR_D				CLD1			
GPIO[26]	33		RI_D	CLK_D			CLD2		TIMER3	
GPIO[27]	31		DCD_D	ENBL_D			CLD3		TIMER4	
GPIO[28]	65						CLD4 (CLD8)		IRQ1	CLD8: Primary on GPIO[32] IRQ1: Primary on GPIO[07]
GPIO[29]	74						CLD5 (CLD9)		TIMER5	CLD9: Primary on GPIO[33]
GPIO[30]	63						CLD6 (CLD10)		TIMER6	CLD10: Primary on GPIO[34]
GPIO[31]	70						CLD7 (CLD11)		TIMER7	CLD11: Primary on GPIO[35] TIMER7: Duplicate on GPIO[06]
GPIO[32]	57						CLD8	PD1	IRQ2	CLD8: Duplicate on GPIO[28] IRQ2: Duplicate on GPIO[11]
GPIO[33]	68						CLD9	PD2		CLD9: Duplicate on GPIO[29]

WHAT'S ON THE MODULE?

Antenna connectors: RP/SMA and U.FL (ConnectCore Wi-9C only)

Signal	SO-DIMM	BootStrap (BS / System / Other)	UART	SPI	I2C	USB	LCD	IEEE 1284	PWM / Timer / IRQ	Notes
GPIO[35]	66				SDA		CLD11	PD4		SDA: Duplicate on GPIO[71] CLD11: Primary on GPIO[13]
GPIO[36]	53						CLD12	PD5	PWM0	PWM0: Duplicate on GPIO[10]
GPIO[37]	64						CLD13	PD6	PWM1	PWM1: Duplicate on GPIO[12]
GPIO[38]	51						CLD14	PD7	PWM2	PWM2: Duplicate on GPIO[13]
GPIO[39]	58						CLD15	PD8	PWM3	PWM3: Duplicate on GPIO[14]
GPIO[40]	56		TXD_C	DOUT_C			CLD16		IRQ3	IRQ3: Duplicate on GPIO[18]
GPIO[41]	54		RXD_C	DIN_C			CLD17			
GPIO[42]	52		RTS_C			DATA+				Add 10-15K pullup if not used
GPIO[43]	48		CTS_C			DATA-		PDIR		Add 10-15K pullup if not used
GPIO[44]	47	BS: Endian Pull down for Big Endian	TXD_D	DOUT_D		OE		PSELO		
GPIO[45]	45		RXD_D	DIN_D		RCV		PSTB#		
GPIO[46]	43		RTS_D			RXD+		PAFD#		RXD+: Only used for unidirectional PHY
GPIO[47]	41		CTS_D			RXD-		PINIT#		RXD-: Only used for unidirectional PHY
GPIO[48]	98					SUSP		PSELI		
GPIO[49]	96	BS: CS_POL				SPD		PLH		
GPIO[66]	36									CR2: Yellow user LED Output drive 8mA
GPIO[67]	34									CR1: Green user LED Output drive 8mA MFGO_CR1
GPIO[68]	NC									No connect
GPIO[69]	28								IRQ1	GPIO[69]: Output drive 8mA IRQ1: Primary on GPIO[07] Add 10-15K pullup if not used
GPIO[70]	26				iic_scl					GPIO[70]: Output drive 8mA iic_scl: Primary on GPIO[34]
GPIO[71]	24				iic_sda					GPIO[71]: Output drive 8mA iic_sda: Primary on GPIO[35]
MFGL_GPIO[72]	22									Reserved

Antenna connectors: RP/SMA and U.FL (ConnectCore Wi-9C only)

The ConnectCore Wi-9C supports two types of antenna connectors: RP-SMA and U.FL. The standard connector population option is 1 RP-SMA connector. Dual diversity operation and custom connector populations are available.

For antenna specifications, see "Antenna information," beginning on page 77.

RP-SMA connectors, P10 and P8

The antenna is connected to the module via a reverse polarity SMA connector (sub-miniature size A). The antenna fits on the module only one way, to ensure proper connection.



Caution: Be sure that your antenna choice complies with the regulatory requirements of your region. In North America, for example, you can operate only with antennas approved by Digi International, Inc., or antennas matching the specifications of the Digi-approved antennas.

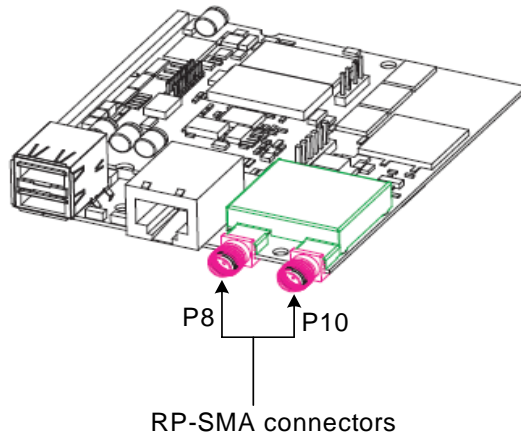

Primary RP-SMA antenna, P10

P10 is the primary RP-SMA antenna, for both receive and transmit. This is the connector/antenna provided with the standard RP-SMA module configuration.

Secondary RP-SMA antenna, P8

P8 is the secondary RP-SMA antenna, used for receive only. This connector/antenna is provided only when you select the

two-RP-SMA population option.

U.FL connectors, P11 and P9

Both U.FL connectors are provided on the module when you select the U.FL population option.

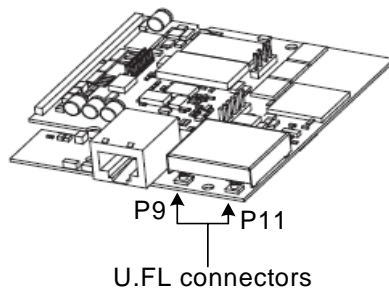

P11 is the primary U.FL antenna, for both receive and transmit. P9 is the secondary U.FL antenna, used for receive only.

WHAT'S ON THE MODULE?

Antenna connectors: RP/SMA and U.FL (ConnectCore Wi-9C only)

About the Development Board

C H A P T E R 3

This chapter provides information for configuring the ConnectCore 9C/Wi-9C development board, and details the development board's default and optional configuration states. The development board serves as a carrier board platform for product evaluation and design. The board is also available as a separate accessory item for quick prototyping purposes.

For more detailed information on the development board, see the documentation available on your Jump Start Kit CD.

Features

The ConnectCore 9C/Wi-9C development board supports these features:

- Four 921kbps serial ports
 - Serial port A: EIA-232/422/485 switch-selectable (DB-9)
 - Serial port B: EIA-232 (DB-9)
 - Serial port C: TTL-level
 - Serial port D: TTL-level
- SPI and I²C interface headers
- Eight digital GPIOs
- Two user LEDs and pushbuttons
- VGA interface
- LCD panel connector
- Application-specific expansion connectors
- Through-hole prototyping area
- +3.3V, +5V, +12V, -12V, and GND test points

- Current measurement option
- Power on/off switch
- 9-30VDC power input
- Board and module mounting holes

Basic description

The development board contains connectors, switches, and LEDs that you use when integrating the ConnectCore 9C or ConnectCore Wi-9C module into your design. The board also provides test points; see “Test points” on page 57 for more information.

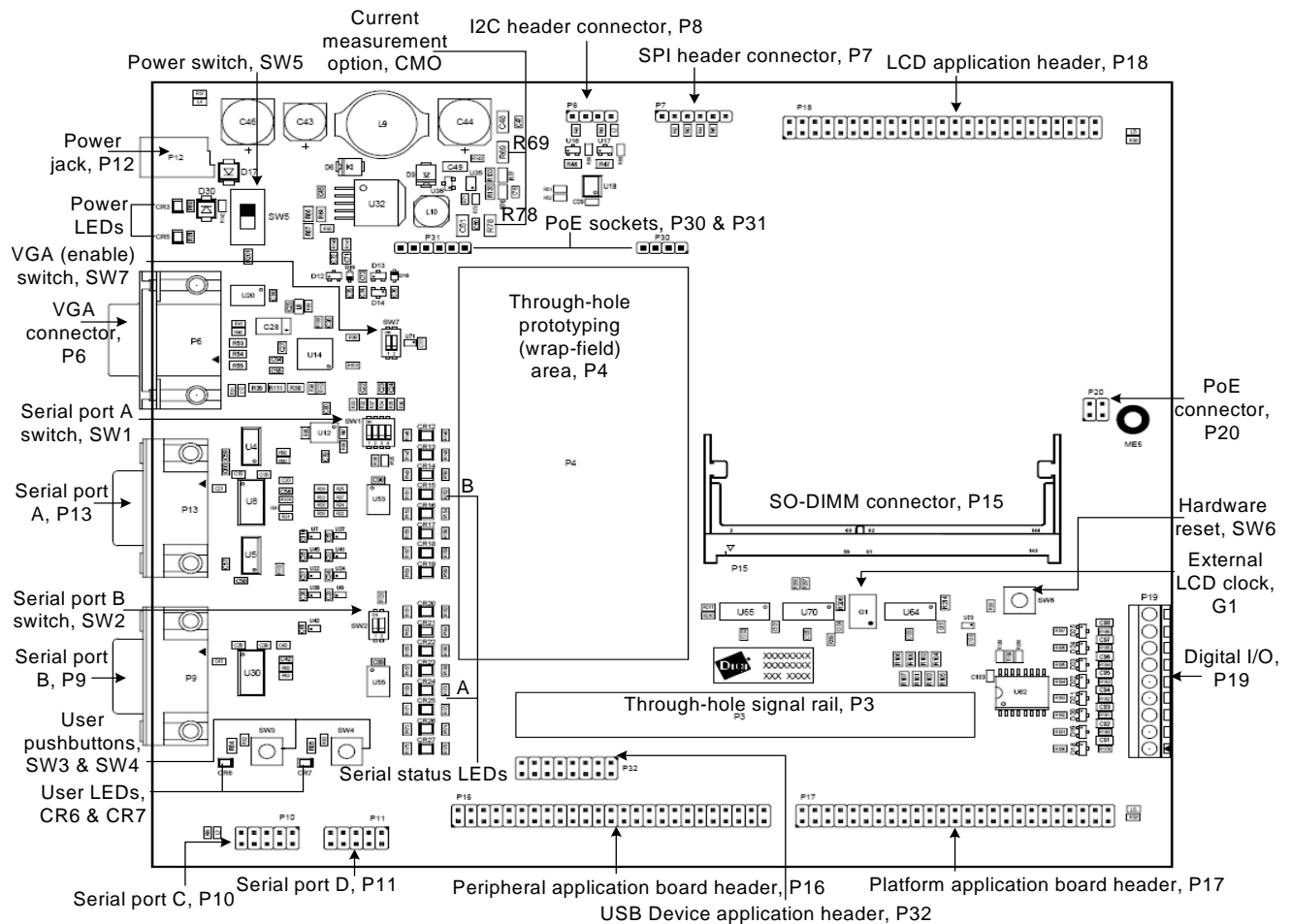

Switches and buttons

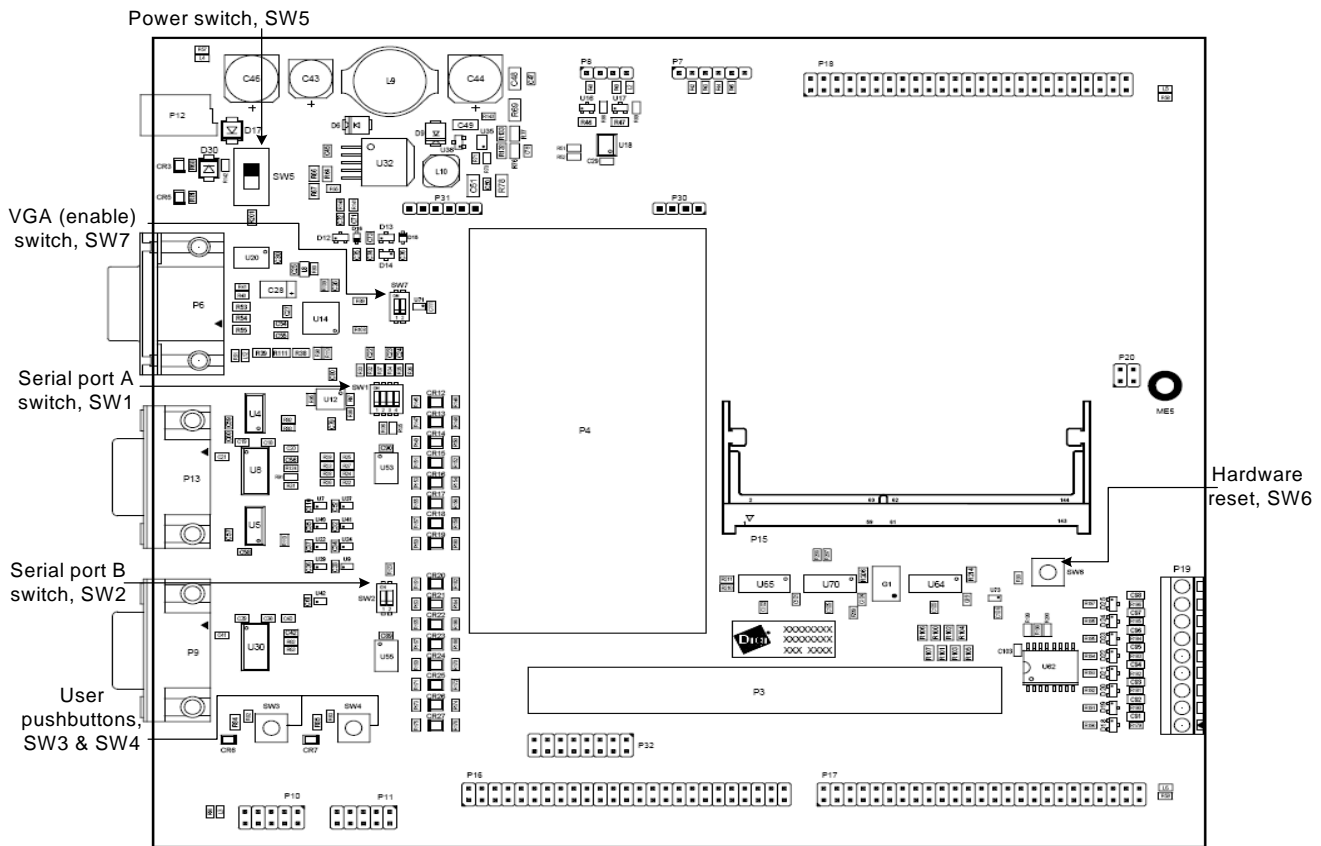

Serial Port A switch, SW1

The Serial Port A switch is a 4-position DIP switch. Use this switch to set the signal modes for serial port A, EIA-232/422/485.

Position	Description	Default position
1	Determines whether the interface is configured for EIA-232 or EIA-485: ON — EIA-232 interface mode OFF — EIA-485 interface mode	ON
2	Enables/disables EIA-232 auto power down: ON — Not supported OFF — Disabled	OFF

Position	Description	Default position
3	Determines whether the interface is configured for 4-wire or 2-wire EIA-485: ON — 2-wire EIA-485 mode OFF — 4-wire EIA-485 mode	OFF
4	Enables/disables termination for the EIA-485/EIA-422 interface: ON — Termination enabled OFF — Termination disabled	OFF

Serial Port B switch, SW2

The Serial Port B switch is a 2-position DIP switch that enables or disables the serial port B transceiver.

Position	Setting	Default position
1	Enable/disable auto power down ON — Not supported OFF — Disabled	OFF
2	Enable/disable EIA-232 transceiver ON — Enabled OFF — Disabled	ON

User pushbuttons, SW3 and SW4

The development board has two user pushbuttons — SW3 and SW4 — that allow you to interact with applications running on the ConnectCore 9C or Wi-9C module. The application detects the button push through the associated GPIO.

SW3 and SW4 pin assignment

Signal name	Switch	GPIO
USER_PUSH_BUTTON_1	SW3	GPIO72
USER_PUSH_BUTTON_2	SW4	GPIO69

Power switch, SW5

SW5 is the main power switch. ON/OFF positions are marked on the development board.

Hardware Reset button, SW6

Press the hardware reset (push) button to reset the whole platform (module and development board).

VGA (enable) switch, SW7

The VGA (enable) switch is a 2-position DIP switch that determines whether GPIO40 and GPIO41 are connected to the VGA controller or available for serial port C (see "Serial port C header connector, P10," beginning on page 37). The switch position

also determines whether the oscillator is connected to GPIO15 or is free for serial port A use.

Setting	VGA interface	GPIO15	GPIO40 / GPIO41
ON	Disabled	DCD_A#	TXD_C/RXD_C
OFF	Enabled (default)	EXT_VGA_OSC	VGA_BLUE6/VGA_BLUE7

I2C and SPI header connectors

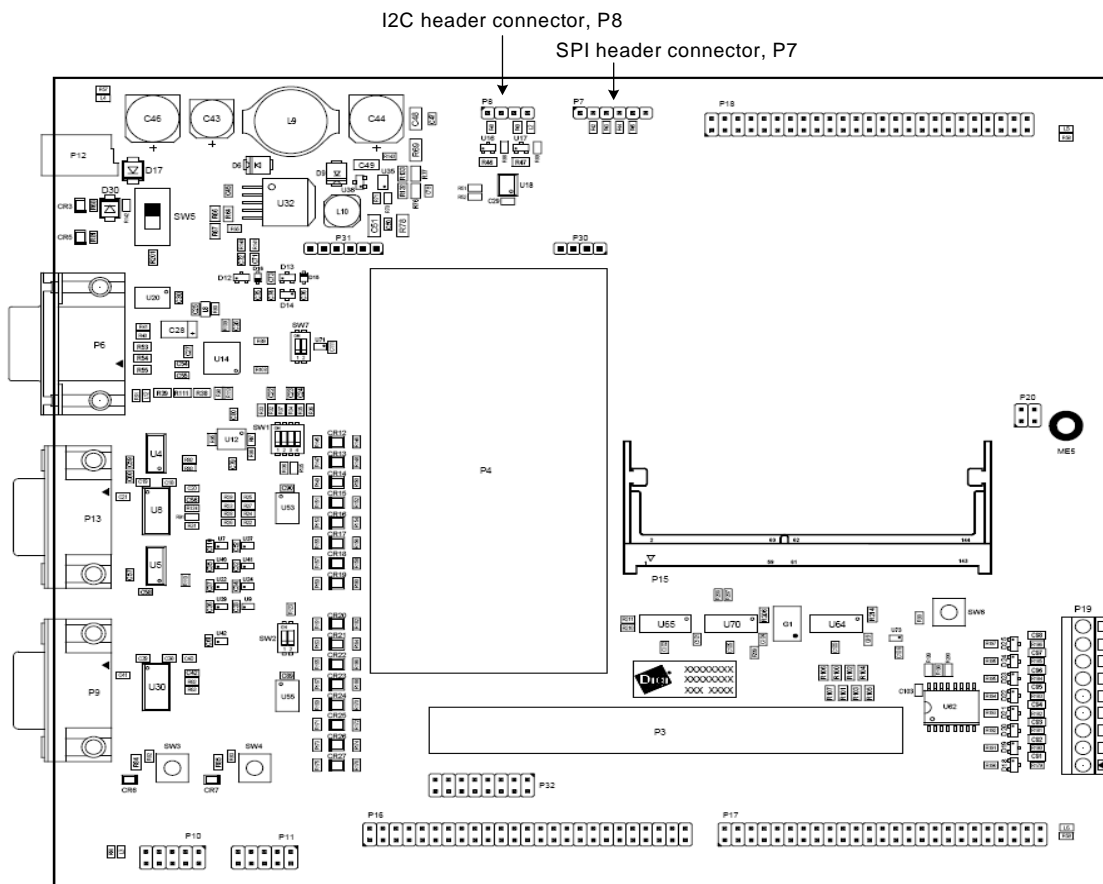

I²C header connector, P8

The development board has a 4-pin I²C header connector, labeled P8.

P8 pin assignment

Pin	Signal	Description
1	I2C_SDA	I ² C serial data line
2	+5V	+5V
3	I2C_SCL	I ² C serial clock line
4	GND	Ground

SPI header connector, P7

The development board has one 6-pin SPI header connector, labeled P7.

Important: If you use the SPI header connector, Serial Port B must be *disabled* (in software).

P7 pin assignment

Pin	Signal	Description
1	+3.3V	+3.3V
2	SPI_DOUT	SPI data out
3	SPI_DIN	SPI data in
4	SPI_CLK	SPI clock
5	SPI_CS#	SPI chip select
6	GND	Ground

All SPI signals are protected for the respective module's boot strapping.

Serial port connectors

The development board has four serial ports: A (P13), B (P9), C (P10), and D (P11). Serial ports A and B support full EIA-232 functionality; serial ports C and D do not.

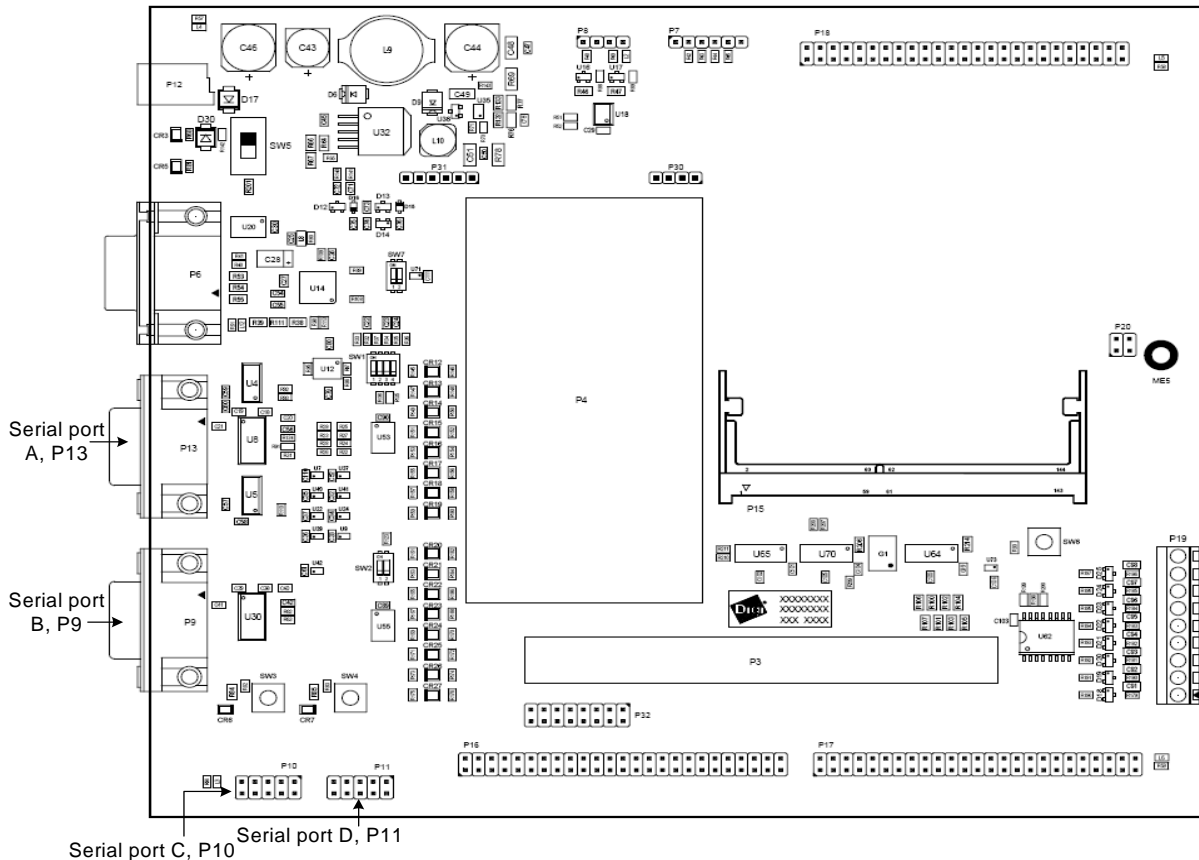

Serial port A (EIA-232/422/485) connector, P13

The serial port A connector is a single DB-9 male connector for EIA-232/EIA-485 switchable mode, labeled P13. The serial port A interface corresponds to NS9360 serial port A, and is a switch-selectable EIA-232/422/485 interface with a maximum baud rate of 921 kbps (see “Serial Port A switch, SW1” on page 31). Each signal is available with its status LED, and all status LEDs are bi-color, red or green.

Serial port A diagram

This diagram shows the switch-selectable EIA-232/422/485 interface:

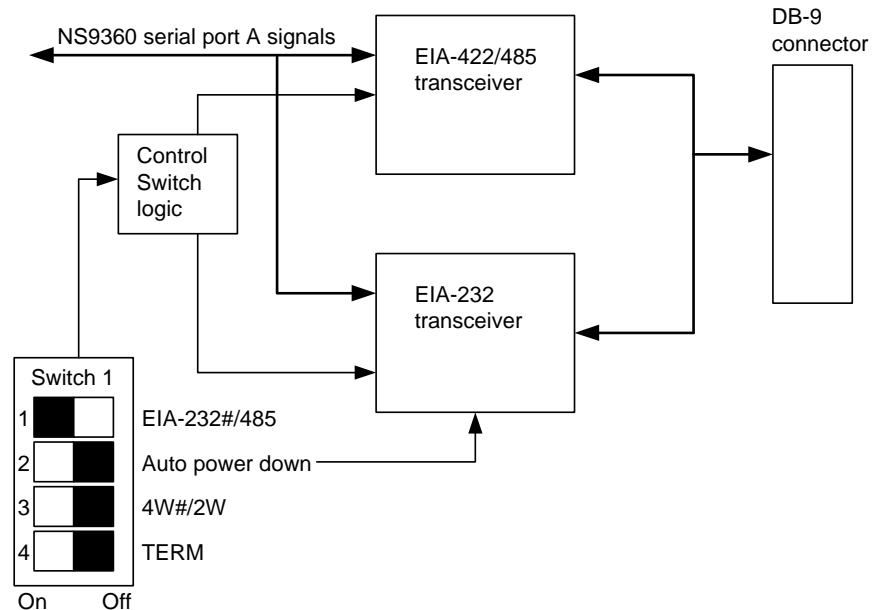

P13 connector pin assignment

Pin	EIA-232 signal	EIA-232 signal description	EIA-422/485 4/8 wire	EIA-485 2-wire
1	DCD# ¹	Data Carrier Detect	CTS- (B)	
2	RXD	Receive Data	RXD+ (A)	DATA+ (A)
3	TXD	Transmit Data	TXD+ (A)	
4	DTR#	Data Terminal Ready	RTS- (B)	
5	GND	Ground	GND	GND
6	DSR#	Data Set Ready	RXD- (B)	DATA- (B)
7	RTS#	Request to Send	RTS+ (A)	
8	CTS#	Clear to Send	CTS+ (A)	
9	RI#	Ring Indicator	TXD- (B)	

1. When the VGA (enable) switch, SW7, is OFF (default), DCD is *not* available. Shell is chassis GND.

Serial port B (EIA-232) connector, P9

The serial port B connector is a single, DB-9 male connector, labeled P9. The serial port B interface corresponds to NS9360 serial port B, and is a standard EIA-232 interface with a maximum baud rate of 921 kbps. Each signal is available with its LED, and all status LEDs are bi-color, red or green.

The serial port B line driver can be disabled using Switch 2 (see "Serial Port B switch, SW2" on page 32).

P9 connector pin assignment

Pin	Signal	Description
1	DCD#	Data Carrier Detect
2	RXD	Receive Data
3	TXD	Transmit Data
4	DTR#	Data Transmit Ready
5	GND	Ground
6	DSR#	Data Set Ready
7	RTS#	Request to Send
8	CTS#	Clear to Send
9	RI#	Ring Indicator

Serial port C header connector, P10

The serial port C header connector is a 2x5-pin serial port, labeled P10. The connector is a UART interface, with signals available on TTL-level. The serial port C interface corresponds to NS9360 serial port C.

The serial port C interface signals are available on TTL-level, and support only the TXD, RXD, RTS#, and CTS# signals, where # indicates an active low signal. These pins default to LCD or DIGITAL_I/O signals when switch 7 is configured for VGA functionality (see “VGA (enable) switch, SW7” on page 32).

P10 connector pin assignment

Pin	Signal	Description	VGA enabled (SW7)
1	Not connected	n/a	n/a
2	Not connected	n/a	n/a
3	RXD_C	Receive Data	LCD_D17
4	RTS_C#	Request to Send	DIGITAL_IO_9
5	TXD_C	Transmit Data	LCD_D16
6	CTS_C#	Clear to Send	DIGITAL_IO_10
7	Not connected	n/a	n/a
8	Not connected	n/a	n/a
9	GND	Ground	n/a
10	+3.3V	Power	n/a

Serial port D header connector, P11

The serial port D header connector is a 2x5-pin serial port, labeled P11. The connector is a UART interface, with signals available on TTL-level. The serial port D interface corresponds to NS9360 serial port D.

The serial port D interface signals are available on TTL-level and support only the TXD, RXD, RTS#, and CTS# signals, where # indicates an active low signal. These pins default to GPIO signals 44-47. To use the pins for serial port D functions, you need to configure them in software.

P11 connector pin assignment

Pin	Signal	Description	Defaults to
1	Not connected	n/a	n/a
2	Not connected	n/a	n/a
3	RXD_D	Receive Data	GPIO45
4	RTS_D#	Request to Send	GPIO46
5	TXD_D	Transmit Data	GPIO44
6	CTS_D#	Clear to Send	GPIO47
7	Not connected	n/a	n/a
8	Not connected	n/a	n/a
9	GND	Ground	n/a
10	+3.3V	Power	n/a

VGA connector / External LCD clock

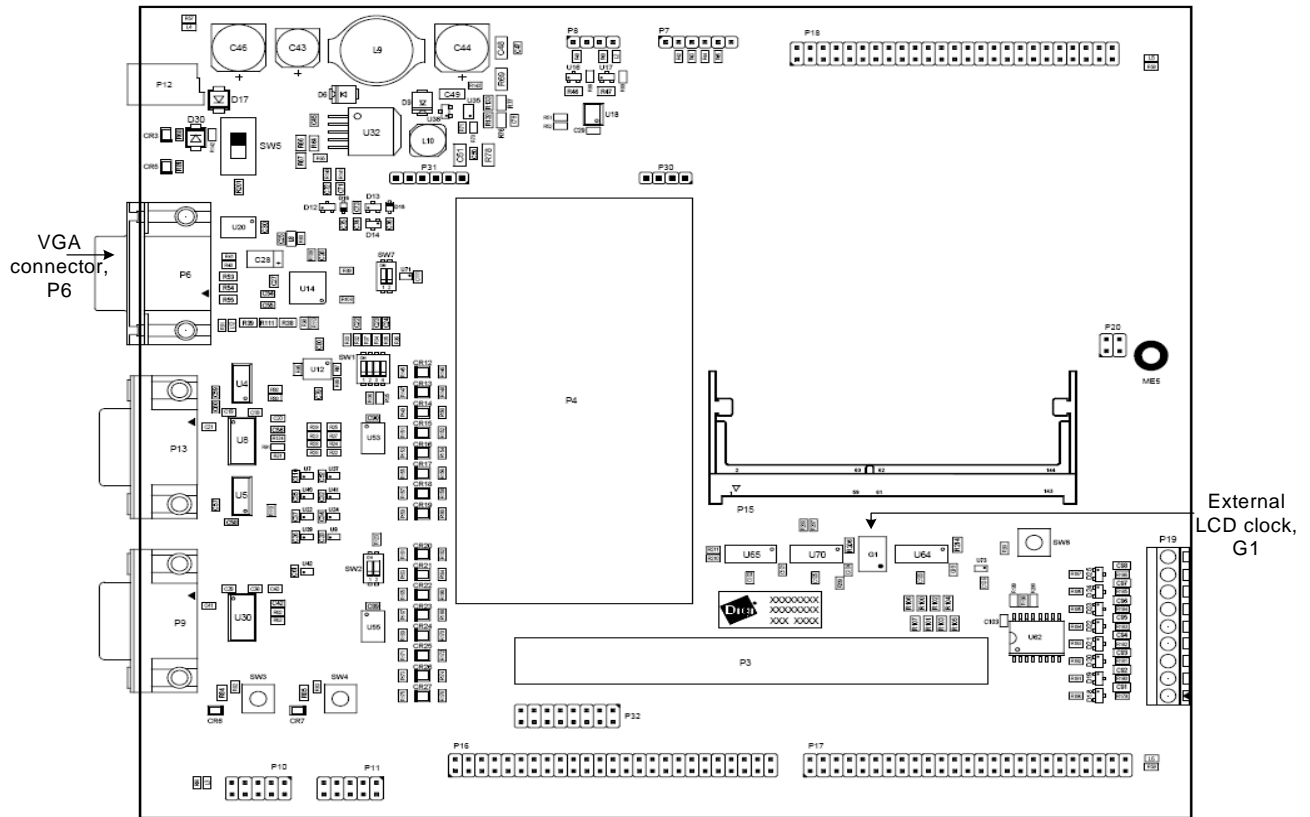

VGA connector, P6

The VGA connector is a 15-pin female connector, labeled P6.

P6 pin assignment

Pin	Signal	Comment
1	VGA_RED	
2	VGA_GREEN	
3	VGA_BLUE	
4	NC (Monitor ID2)	Monitor ID2 is not implemented on the development board
5	GND	
6	VGA_GND (RED_RETURN)	
7	VGA_GND (GREEN_RETURN)	
8	VGA_GND (BLUE_RETURN)	
9	NC	

Pin	Signal	Comment
10	GND (SYNC_RETURN)	
11	NC (Monitor ID0)	Monitor ID0 is not implemented on the development board
12	NC	
13	HSYNC	
14	VSYNC	
15	NC	

External LCD clock, G1

An external LCD controller clock is provided to avoid picture quality deterioration due to the low-emission spread spectrum clock used on the module.

G1 is a 48MHz oscillator that supports resolutions up to 640 x 480. The maximum NS9360 external LCD clock frequency is 90MHz. The frequency is divided by 2 before being used as the LCD clock source. For more information, see "Sample applications," beginning on page 61.

Development board SO-DIMM connector, P15

Manufacturer part number: AMP INCORPORATED 390112-1

P15 is a 144-pin SO-DIMM connector on the development board. Plug the ConnectCore 9C/Wi-9C module SO-DIMM connector, P3, into P15.

Note: The clearance between the module and your development board must be 2.54mm (0.10").

Bird's-eye view

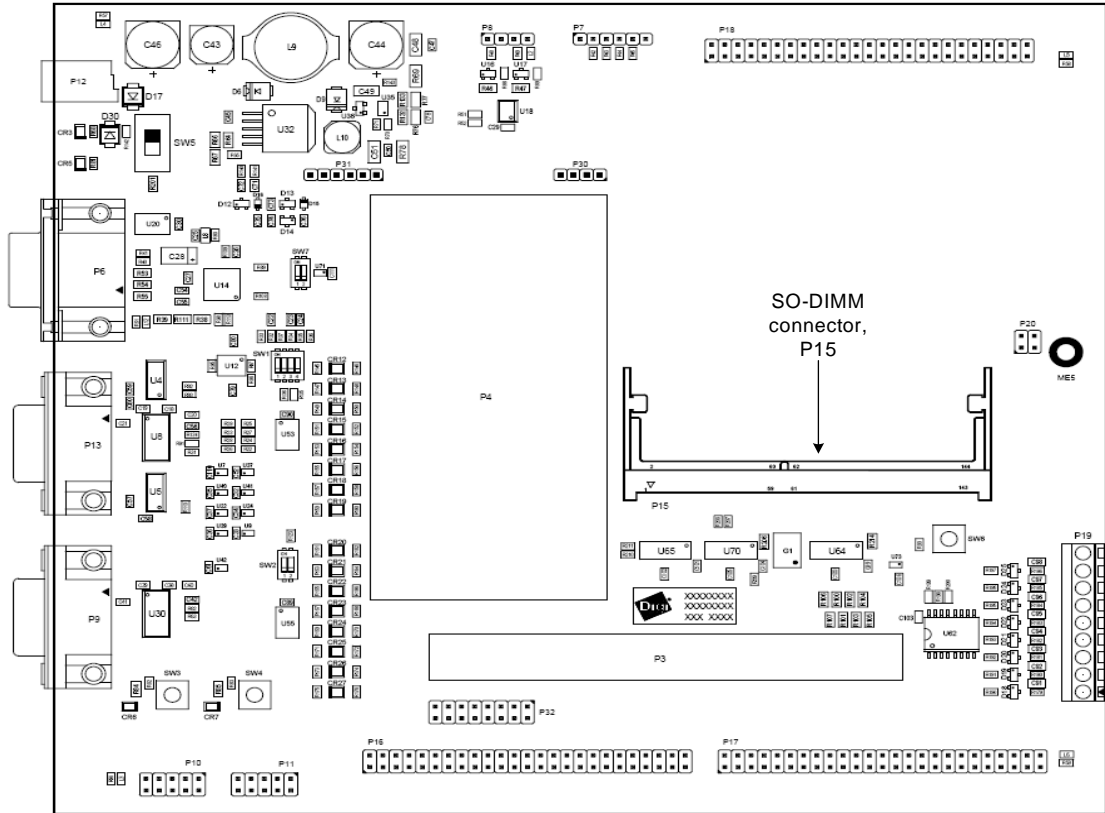

Close-up

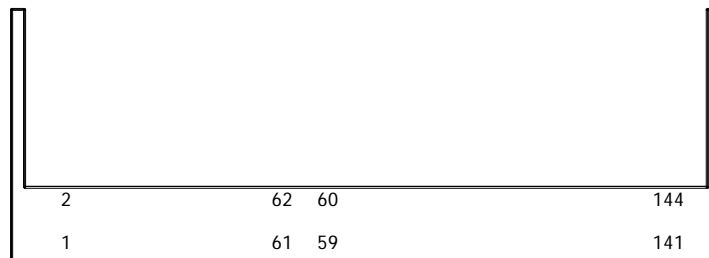

Inserting the module into the SO-DIMM connector

To be sure you insert the module into the SO-DIMM connector properly, review these steps and figures:

- 1 Align the module key with the housing key (see Figure 1).
- 2 Slide the module into the housing (see Figure 1),
- 3 Push the board down until the module snaps in (see Figure 2).

Be sure the metal latching edge engages the edge of the module.

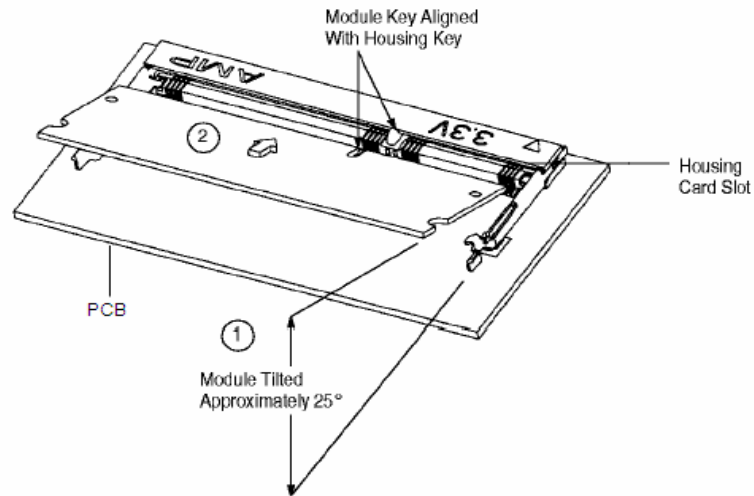

Figure 1: Inserting the module into the development board SO-DIMM connector, steps 1 & 2

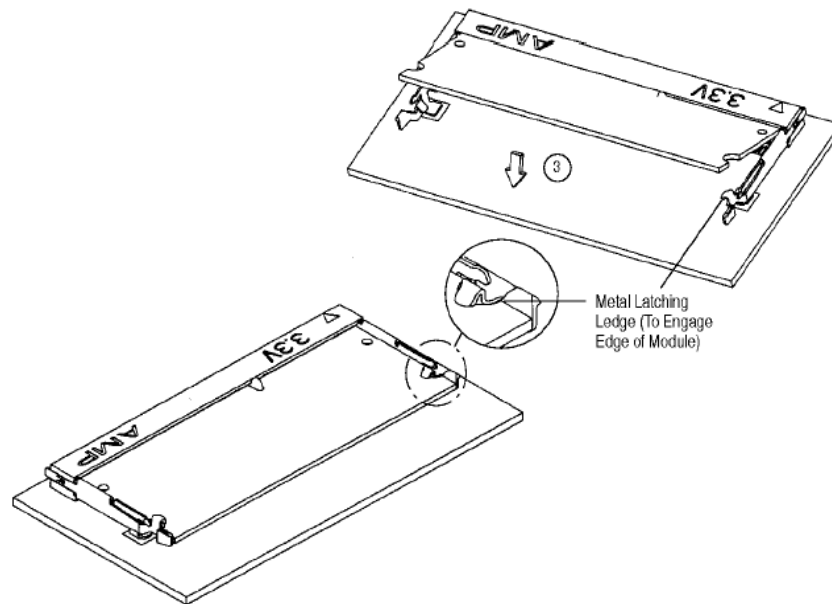

Figure 2: Inserting the module into the development board SO-DIMM connector, step 3

P15 pin assignment

The pin assignment for P15 is the same as that for P3, the SO-DIMM connector on the module. For the complete pin assignment list, see "Pin assignment by SO-DIMM pin number," beginning on page 19.

Application-specific expansion headers — P16 and P17

Manufacturer part numbers:

SAMTEC TSM-125-02-L-DV

PINREX 212-92-25GB01

WAVE TECH EPS01-50-A-1-0-B

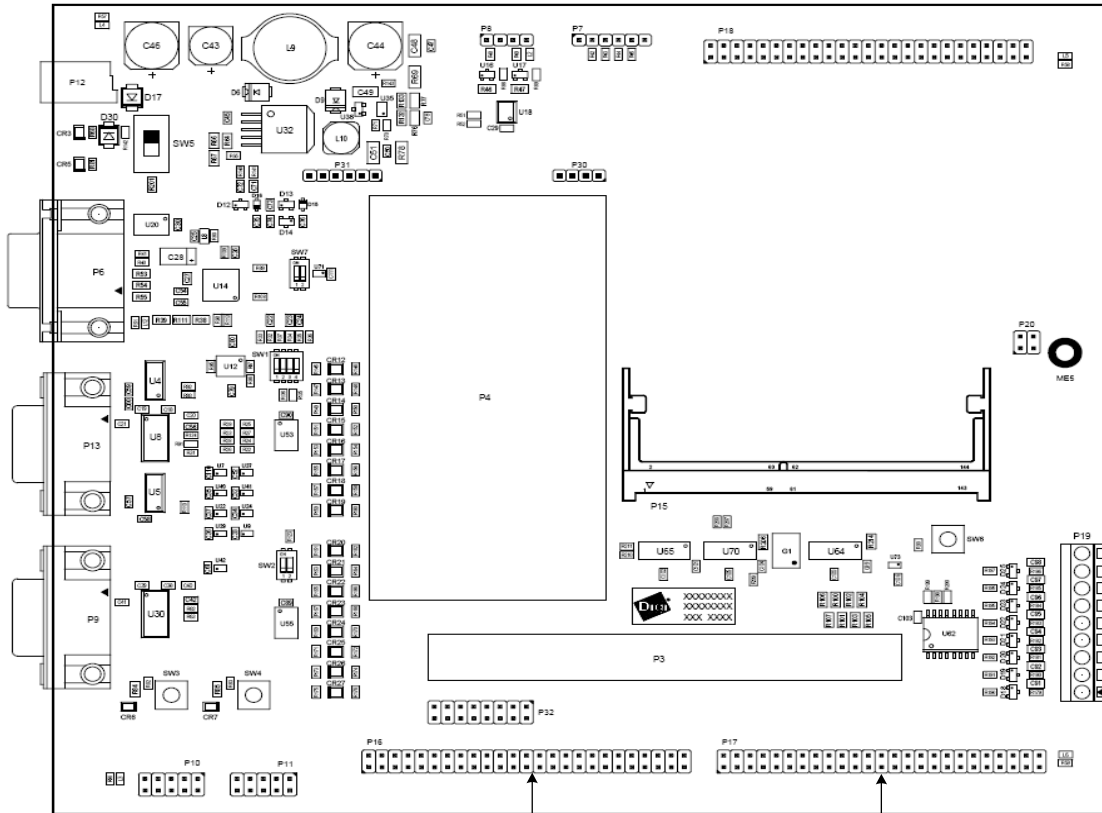

Peripheral application board header, P16 Platform application board header, P17

The development board provides two, 2x25-pin, 0.10" (2.54mm) pitch headers for supporting application-specific daughter cards/expansion boards:

- **P16, Peripheral board header.** Provides access to an 8-bit data bus, 8-bit address bus, and control signals (for example, CS#, WE#), as well as I²C and power. Using these signals, you can connect Digi-specific extension modules or your own daughter card to the module's address/data bus.
- **P17, Platform application header.** Provides access to the serial port B signal, one SPI interface, one USB channel, eight GPIOs, power, and the module's IEEE 802.3af signals. You can attach Digi-provided application kits or your own daughter card design.

**Peripheral
application board
header, P16**

Pin	Signal	Description / Comment	Pin	Signal	Description / Comment
1	GND	Ground	2	DATA_0	Data bus
3	DATA_1	Data bus	4	DATA_2	Data bus
5	DATA_3	Data bus	6	GND	Ground
7	DATA_4	Data bus	8	DATA_5	Data bus
9	DATA_6	Data bus	10	DATA_7	Data bus
11	GND	Ground	12	Reserved (DATA_8)	n/a
13	Reserved (DATA_9)	n/a	14	Reserved (DATA10)	n/a
15	Reserved (DATA_11)	n/a	16	GND	Ground
17	Reserved (DATA_12)	n/a	18	Reserved (DATA_13)	n/a
19	Reserved (DATA_14)	n/a	20	Reserved (DATA_15)	n/a
21	GND	Ground	22	+3.3V	8 bit /16 bit# 3.3V selects 8-bit data bus
23	GND	Ground	24	+3.3V	Power
25	+3.3V	Power	26	ADDRESS_0	Address bus
27	ADDRESS_1	Address bus	28	ADDRESS_2	Address bus
29	ADDRESS_3	Address bus	30	GND	Ground
31	ADDRESS_4	Address bus	32	ADDRESS_5	Address bus
33	ADDRESS_6	Address bus	34	ADDRESS_7	Address bus
35	GND	Ground	36	Reserved (ADDRESS_8)	n/a
37	Reserved (ADDRESS_9)	n/a	38	GND	Ground
39	CS#	Static memory chip select 0	40	I2C_SDA / GPIO71	I ² C serial data line
41	WE#	Write enable	42	OE#	Output enable
43	I2C_SCL / GPIO70	I ² C serial clock line	44	PERI_INT#	USER_PUSH_BUTTON2 / PERI_INT0# / GPIO69
45	+3.3V	Power	46	+3.3V	Power
47	PERI_GPIO0	DIGITAL_IO_9 / UART3_RTS / GPIO42_PRT	48	PERI_GPIO1	DIGITAL_IO_10 / UART3_CTS# / GPIO43_PRT
49	RESET_OUT	Connected to inverted BUFFENR# signal	50	GND	Ground

**Platform
application board
header, P17**

Pin	Signal	GPIO/Other	Pin	Signal	GPIO/Other
1	GND	n/a	2	TXD_B / SPI_DO	GPIO0
3	RXD_B / SPI_DI	GPIO1	4	CTS_B#	GPIO3
5	DSR_B#	GPIO5	6	DCD_B# / SPI_CE	GPIO7
7	RI_B# / SPI_CLK	GPIO6	8	DTR_B#	GPIO4
9	RTS_B#	GPIO2	10	GND	n/a
11	I2C_SCL	GPIO70	12	I2C_SDA	GPIO71
13	GND	n/a	14	RST#	System reset
15	GND	n/a	16	DP1	n/a
17	DM1	n/a	18	GND	n/a
19	LCD_D2	GPIO26	19	LCD_D3	GPIO27
21	TXD_D	GPIO44	22	RXD_D	GPIO45
23	GND	n/a	24	+3.3V	n/a
25	GND	n/a	26	+3.3V	n/a
27	DIGITAL_IO_1	GPIO23	28	DIGITAL_IO_2	GPIO16
29	DIGITAL_IO_3	GPIO17	30	DIGITAL_IO_4	GPIO18
31	USER_LED_1 / DIGITAL_IO_5	GPIO66	32	GND	n/a
33	USER_LED_2 / DIGITAL_IO_6	GPIO67	34	DIGITAL_IO_9 / RTS_C#	GPIO42
35	DIGITAL_IO_10 / CTS_C#	GPIO43	36	GND	n/a
37	Not connected	n/a	38	Not connected	n/a
39	Not connected	n/a	40	Not connected	n/a
41	Not connected	n/a	42	Not connected	n/a
43	Not connected	n/a	44	Not connected	n/a
45	Not connected	n/a	46	Not connected	n/a
47	Not connected	n/a	48	Not connected	n/a
49	Not connected	n/a	50	Not connected	n/a

LCD application board header, P18

Manufacturer part numbers:

SAMTEC TSM-125-02-L-DV

PINREX 212-92-25GB01

WAVE TECH EPS01-50-A-1-0-B

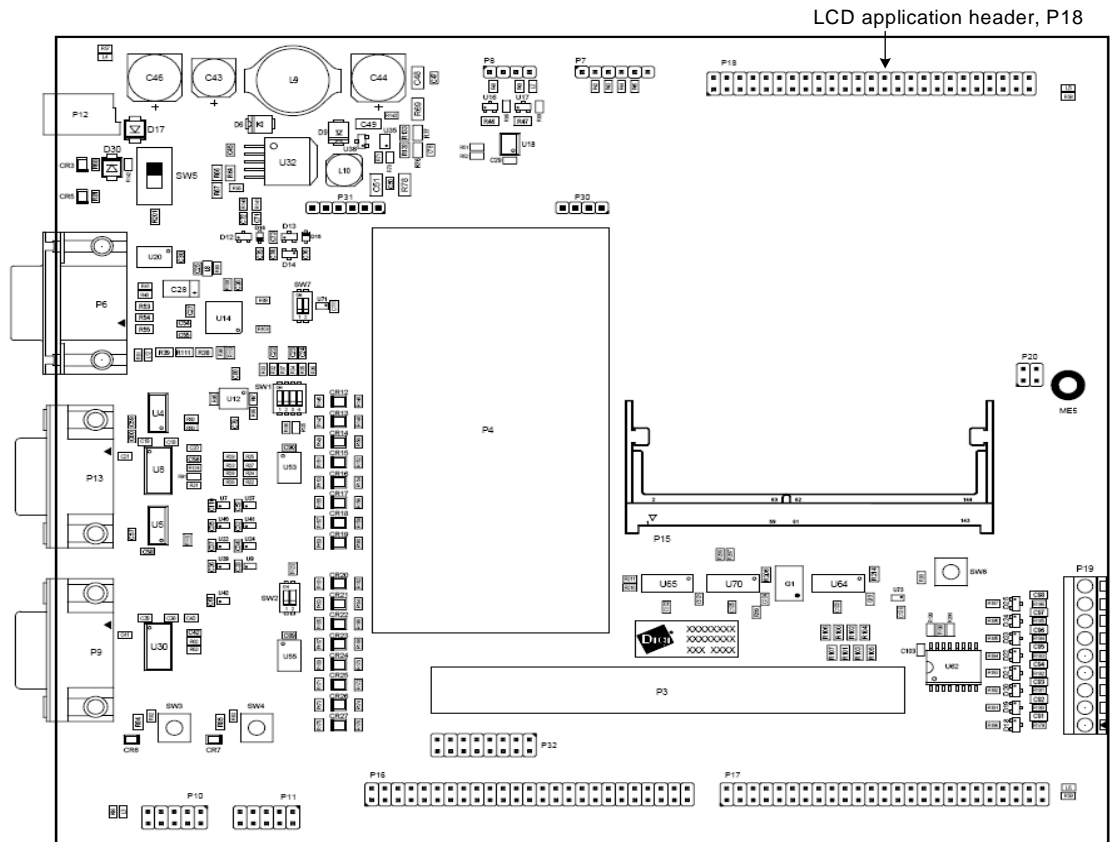

The LCD application header, P18, is a 2x25-pin, 0.10" (2.54mm) pitch header that provide access to the LCD signals and SPI signals for touch controller purposes. Use with the Digi-provided LCD application kit or attach your own LCD application board.

**P18 pin
assignment**

Pin	Signal	GPIO/Other	Pin	Signal	GPIO/Other
1	GND	N/A	2	LCD_D0	GPIO24
3	LCD_D1	GPIO25	4	LCD_D2	GPIO26
5	LCD_D3	GPIO27	6	GND	N/A
7	LCD_D4	GPIO28	8	LCD_D5	GPIO29
9	LCD_D6	GPIO30	10	LCD_D7	GPIO31
11	GND	N/A	12	LCD_D8	GPIO32
13	LCD_D9	GPIO33	14	LCD_D10	GPIO34
15	LCD_D11	GPIO35	16	GND	N/A
17	LCD_D12	GPIO36	18	LCD_D13	GPIO37
19	LCD_D14	GPIO38	20	LCD_D15	GPIO39
21	GND	N/A	22	LCD_D16 / TXD_C#	GPIO40
23	LCD_D17 / RXD_C#	GPIO41	24	GND	(Reserved) LCD_D18
25	GND	(Reserved) LCD_D19	26	GND	N/A
27	GND	(Reserved) LCD_D20	28	GND	(Reserved) LCD_D21
29	I2C_SDA	GPIO71	30	I2C_SCL	GPIO70
31	GND	N/A	32	LCD_CLOCK	GPIO20
33	LCD_BIAS	GPIO22	34	LCD_HSYNC	GPIO19
35	LCD_VSYNC	GPIO21	36	PENIRQ#	GPIO18
37	LCD_PWREN#	GPIO23	38	+3.3V	N/A
39	GND	(Reserved) TSPX	40	GND	(Reserved) TSPY
41	GND	(Reserved) TSMX	42	GND	(Reserved) TSMY
43	+3.3V	N/A	44	RI_B# / SPI_CLK	GPIO6
45	DCD_B# / SPI_CE#	GPIO7	46	TXD_B / SPI_DO	GPIO0
47	RXD_B / SPI_DI	GPIO1	48	+3.3V	N/A
49	GND	TOUCH/SPI#	50	GND	N/A

USB Device application header, P32

Manufacturer part number: EPT 972-08009-21

The USB Device application header, P32, is a press fit 2x8 pin, straight RM2.54 (Y=6.7mm) header. Use this header to connect an external USB Device application to the development board, which then provides USB Device functionality.

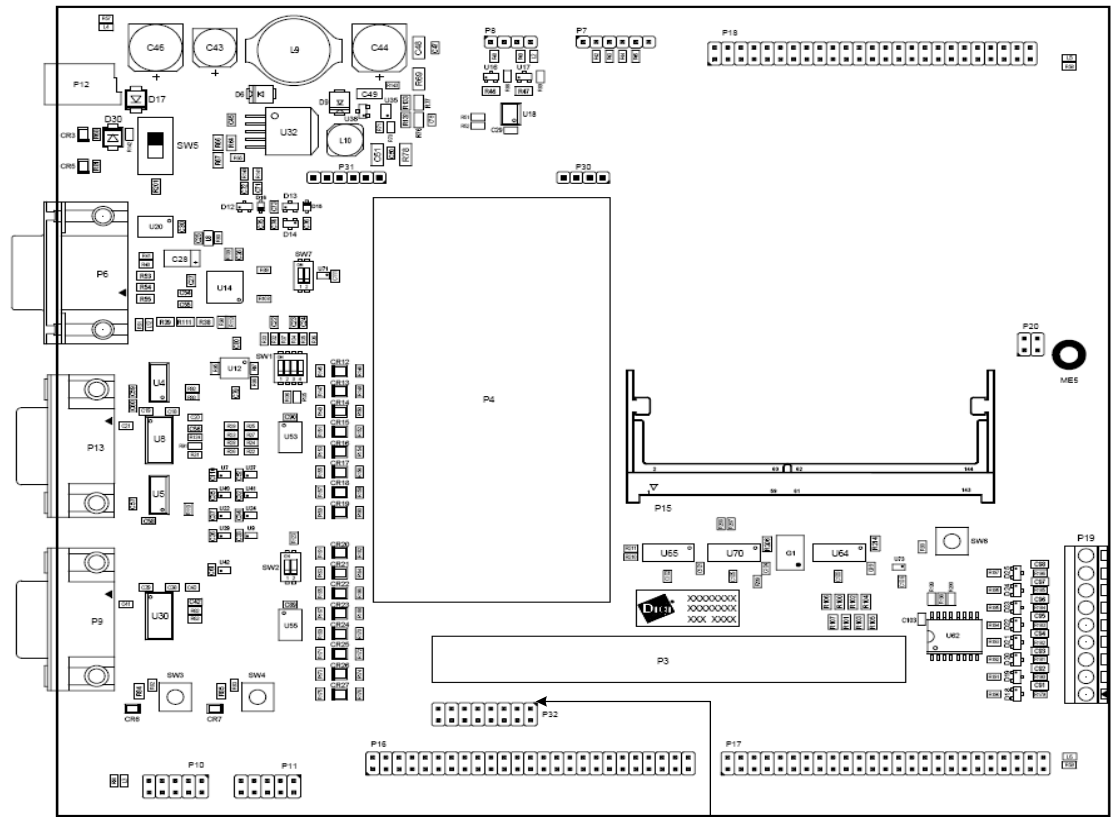

USB Device application header, P32

P32 pin assignment

Pin	Signal	Comment
1	+3.3V	
2	GND	
3	+5V	
4	GND	
5	DIGITAL_IO_9 / UART3_RTS# / GPIO42_PRT	USB_VP functionality
6	DIGITAL_IO_10 / UART3_CTS# / GPIO43_PRT	USB_VM functionality
7	GND	
8	GND	

Pin	Signal	Comment
9	GPIO44 / UART4_TXD / SPID_DO_PRT	USB_OE# functionality
10	USER_LED_3 / DIGITAL_IO_7 / GPIO48	USB_SPND functionality
11	USER_LED_4 / DIGITAL_IO_8 / GPIO49	USB_SPEED functionality
12	GPIO45 / UART4_RXD / SPID_DI_PRT	USB_RCV functionality
13	GPIO46 / UART4_RTS#_PRT	USB_ENUM functionality
14	GND	
15	I2C_SDA / GPIO71_PRT	
16	I2C_SCL / GPIO70_PRT	

Digital I/O, P19

Manufacturer part number: BlockMaster MTS0900T

The Digital I/O connector, P19, is a MTS, 9-pin terminal block for PCB RM3.81.

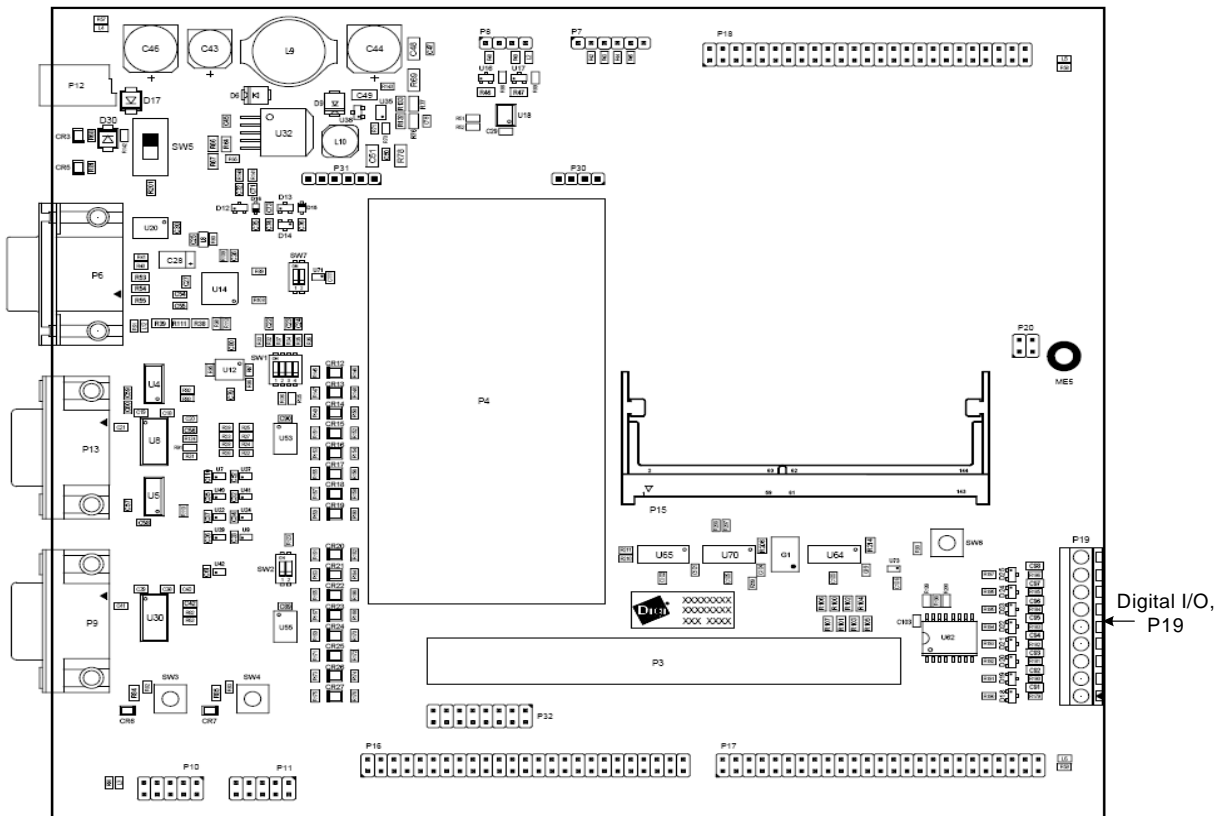

P19 pin assignment

Pin	Signal	Pin	Signal
1	I2C_IO_0	2	I2C_IO_1
3	I2C_IO_2	4	I2C_IO_3
5	I2C_IO_4	6	I2C_IO_5
7	I2C_IO_6	8	I2C_IO_7
9	GND		

Power over Ethernet (PoE) connectors

The development board provides three PoE connectors: P20, P30, and P31.

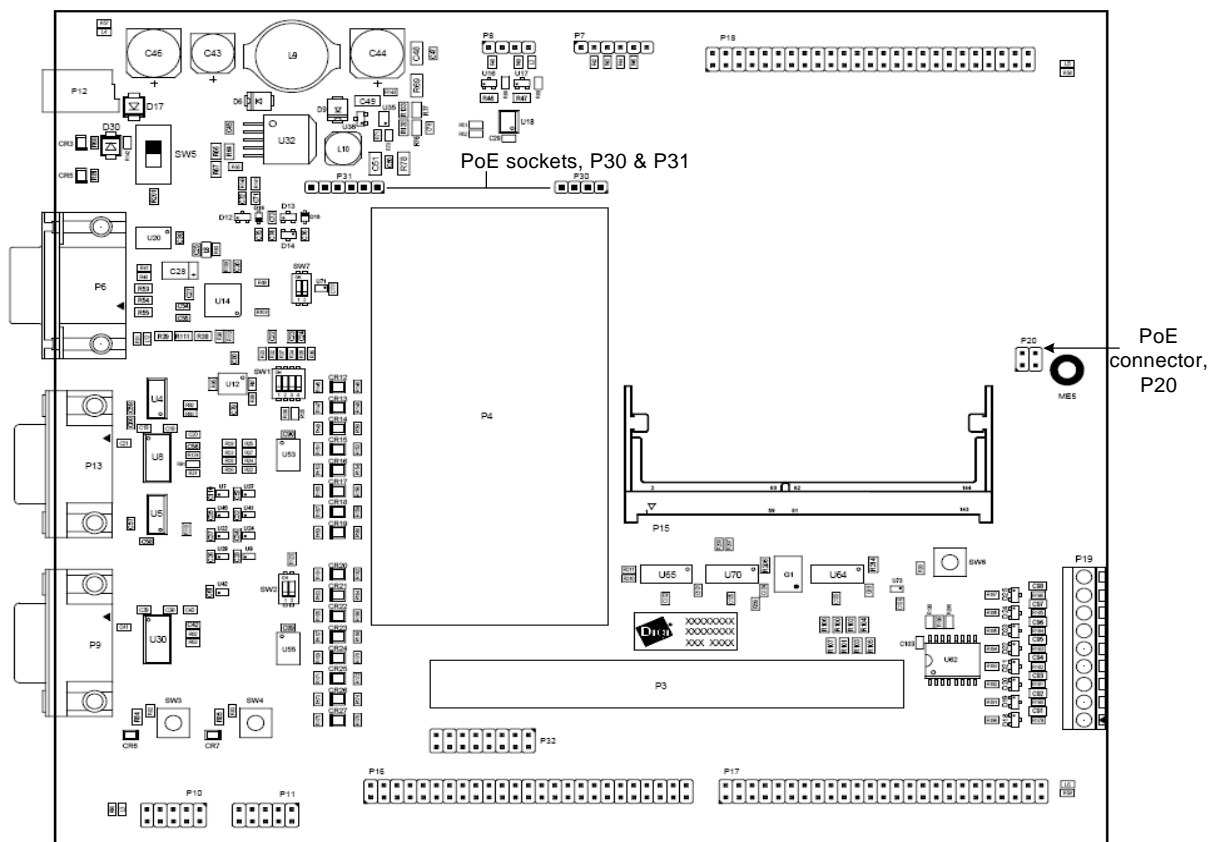

The PoE connector, P20, captures PoE signals from the module on the development board and routes them to the PoE module connector, P30. See “802.3af Power over Ethernet (PoE) pass-through connector, P5” on page 13 for more information.

The P30 and P31 connectors support the IEEE 802.3af PoE application module.

- P30 is the input connector of the PoE module, providing access to the PoE signals coming from the ConnectCore 9C/Wi-9C module through P20.
- P31 provides the output voltage and ground signals from the PoE module. When you use PoE, this output voltage powers the development board; you do not need the main power supply.

802.3afPoE connector, P20

Manufacturer part numbers:

AMP INCORPORATED 5-146256-2

AMP INCORPORATED 5-146257-2

SAMTEC TSW-102-07-L-D

P20 pins are allocated as shown:

Pin	Signal	Actual signal name	Description
1	POE_TX_CT	POE_RJ45_4/5	Ethernet connector pins 4 and 5
2	POE_RJ45_7/8	POE_RX_CT	Ethernet transformer receive CT
3	POE_RX_CT	POE_RJ45_7/8	Ethernet connector pins 7 and 8
4	POE_RJ45_4/5	POE_TX_CT	Ethernet transformer transmit CT

P30 connector

Manufacturer part number: Samtec SLW-104-01-G-S

The P30 input connector is a 1x4 pin socket with these characteristics: SLW, THT, RM2.54 (h=4.57mm). P30 pins are allocated as shown:

Pin	Signal
1	POE_TX_CT
2	POE_RX_CT
3	POE_RJ45_4/5
4	POE_RJ45_7/8

P31 connector

Manufacturer part number: Samtec SLW-106-01-G-S

The P31 connector is a 1x6 pin socket with these characteristics: SLW, THT, RM2.54 (h=4.57mm). P31 pins are allocated as shown:

Pin	Signal	Pin	Signal
1	+12V_POE	2	+12V_POE
3	GND	4	GND
5	POE_GND	6	POE_GND

Through-hole prototyping (wrap-field) area, P3 and P4

The through-hole prototyping area has two parts, P3 and P4.

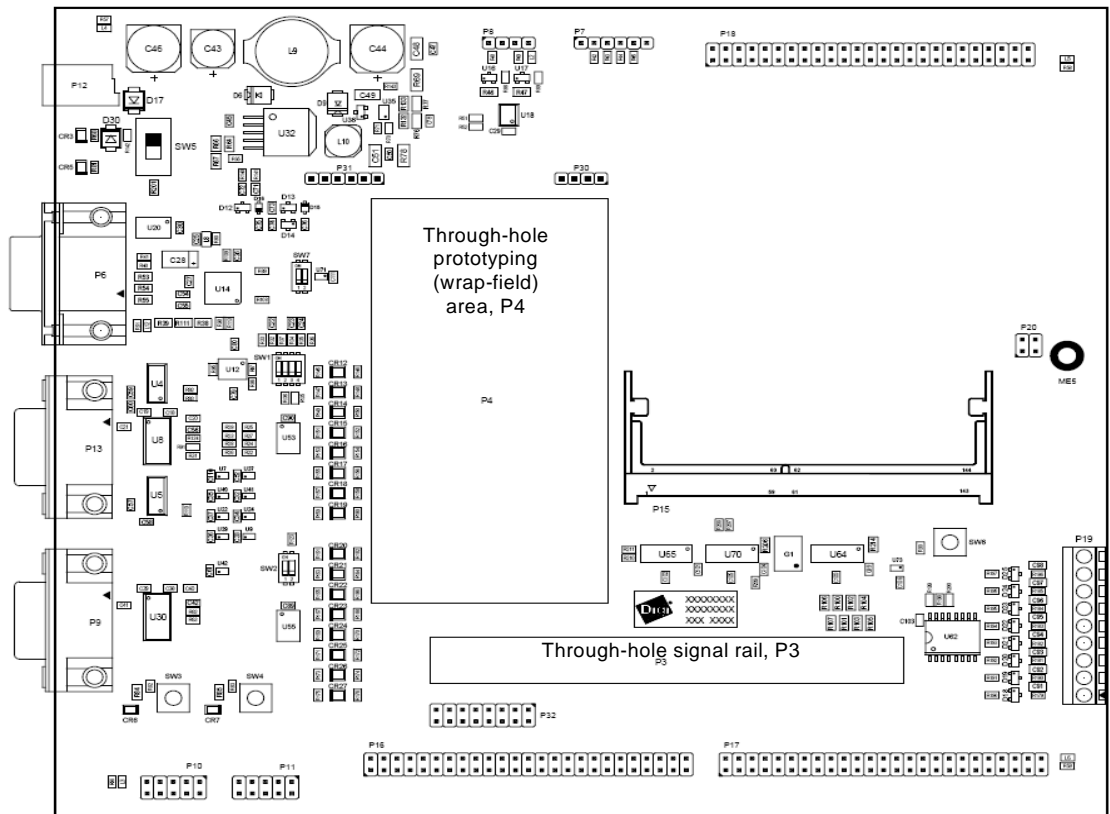

Through-hole signal rail, P3

Manufacturer part number: SAMTEC TSW-136-xx-D

where *xx* is the length of the header pins; you choose the connector that best fits your application. P3 is a four-column, 144-signal, through-hole signal rail that provides 1:1 access to all module signals. You can solder every 2.54mm through-hole header. The size of the P3 connector is 4x36 pins (see the drawing following the next paragraph) – note, however, that you can solder only a smaller header onto the connector. If you want to solder a complete header over the through-hole signal rail, use 2 headers of 2x36 pins each.

The signal assignments for P3 are the same as those for the edge connector, P3, on the module; see "Pin assignment by SO-DIMM pin number," beginning on page 19, for detail.

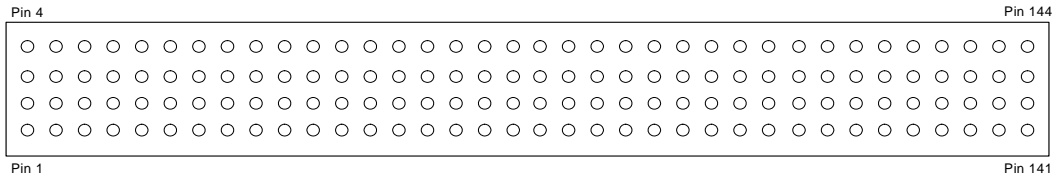

**Wrap-field area,
P4**

P4 is a wrap field area that allows you to connect through-hole components. The +3.3, +5V, and GND buses run along the top edge of the wrap-field area.

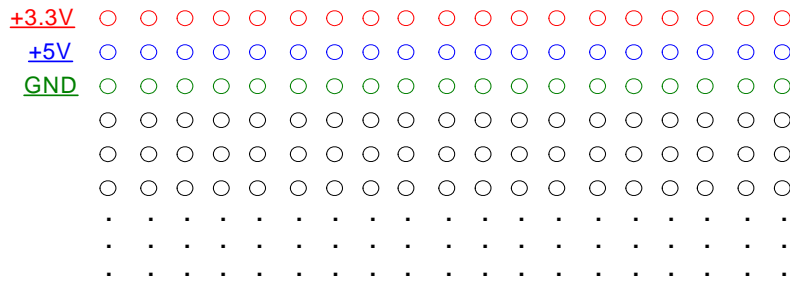

Development board LEDs

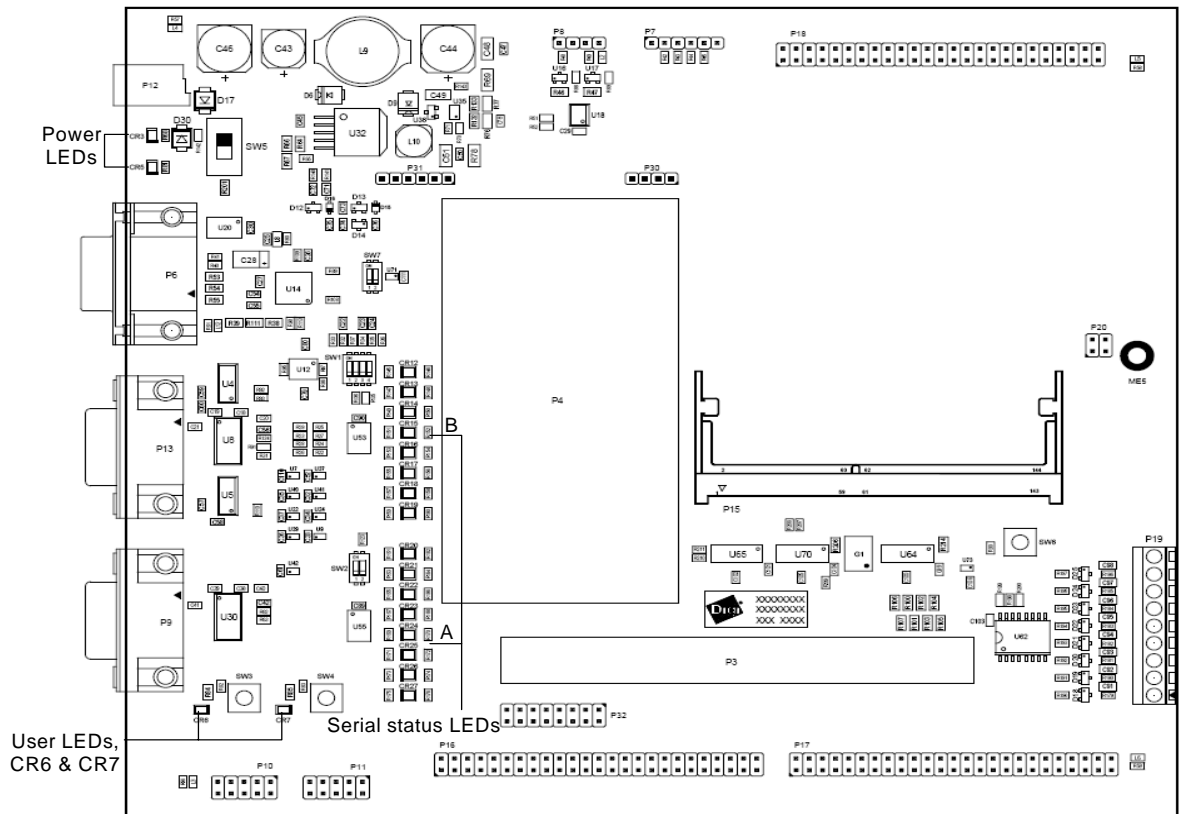

Power LEDs, CR3 and CR5

The power LEDs are single-color (RED) LEDs, located below the power jack, P12.

LED	Condition when ON
CR3	5V power is present
CR5	3.3V power is present

















User LEDs, CR6 and CR7

The user LEDs are single-color (GREEN) LEDs, located next to switches 3 and 4 on the development board.

LED	Condition when ON
CR6	Value of GPIO48 is a logic 0
CR7	Value of GPIO49 is a logic 0.

Serial LEDs

The serial port A LEDs are to the right of the serial port A (EIA-232/EIA-485) connector, on the left side of the wrap-field area. The serial port B LEDs are to the right of the serial port B (EIA-232) connector, on the left side of the wrap-field area.

Serial port A LEDs	Name	Function	Serial Port B LEDs	Name	Function
	CR12	DCD#		CR20	DCD#
	CR13	RI#		CR21	RI#
	CR14	DSR#		CR22	DSR#
	CR15	DTR#		CR23	DTR#
	CR16	CTS#		CR24	CTS#
	CR17	RTS#		CR25	RTS#
	CR18	RXD		CR26	RXD
	CR19	TXD		CR27	TXD

The LED indicators are dual-state, and are connected to the TTL side of the EIA transceivers.

- Green represents a negative voltage on the DB9 connector pin.
- Red represents a positive voltage DB9 connector pin.

The intensity and color of the LED will change when the voltage is switching.

Current Measurement Option (CMO)

The Current Measurement Option uses 0.025R series resistors to measure the current on the development board's +3.3V (R78) and +5V (R69) power supplies.

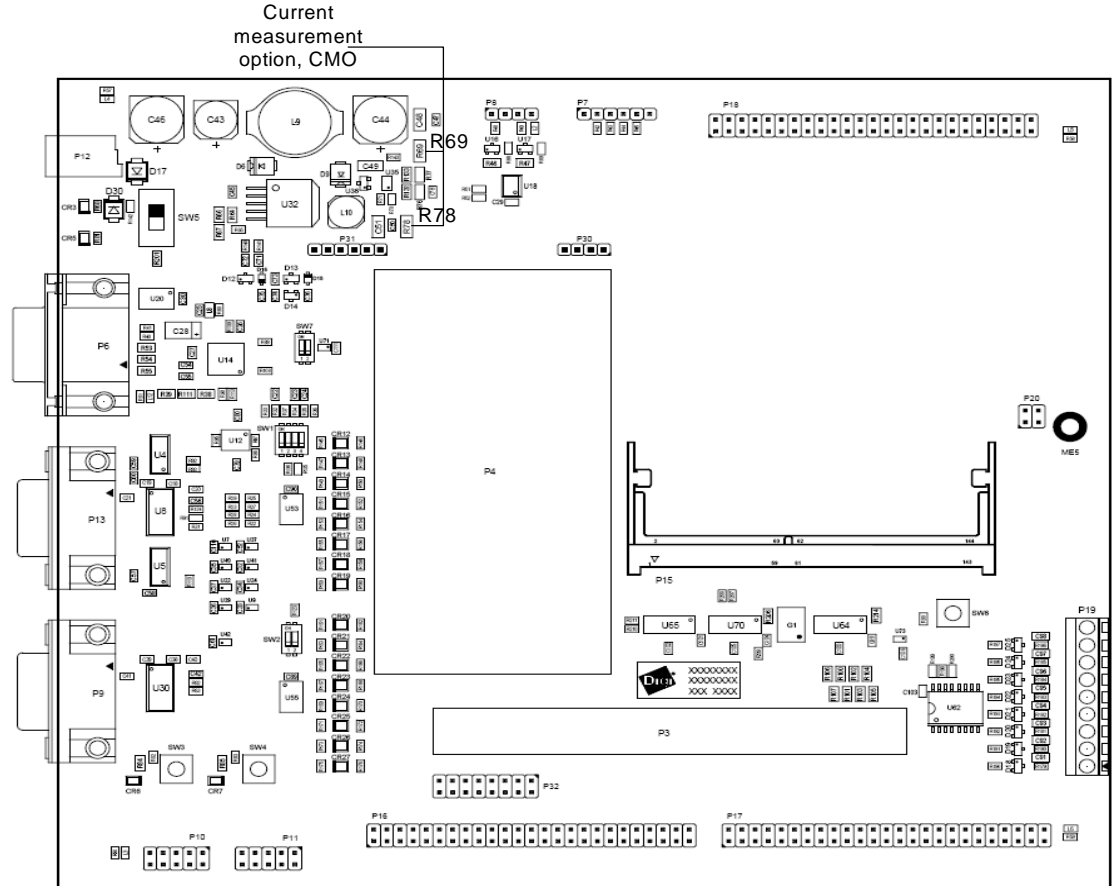

How the CMO works

This drawing shows how the Current Measurement Option works.

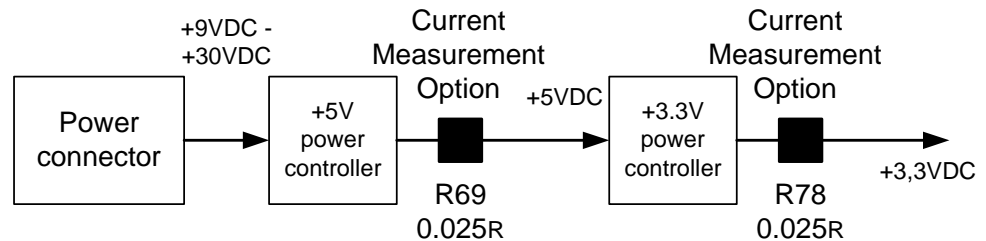

To measure the load current used on different power supplies, measure DC voltage across the sense (CMO) resistor. The value of the resistor is $0.025R \pm 1\%$. Calculate the current using this equation: $I = E/R$

where

- I = current in Amps
- E = measured voltage in Volts
- R = 0.025 Ohms

Power jack, P12

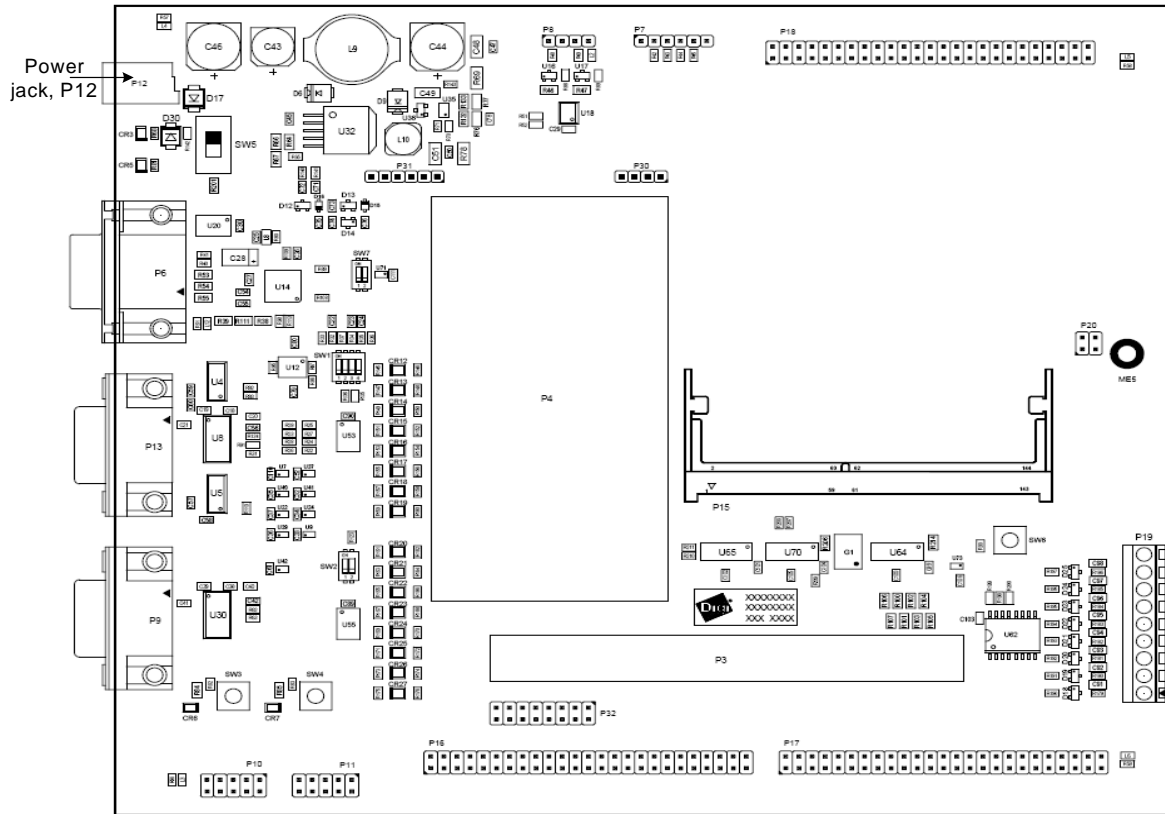

The power jack is a barrel connector with 9-30VDC operating range. The power jack is labeled P12 on the development board. This figure schematically represents the power jack's polarity:

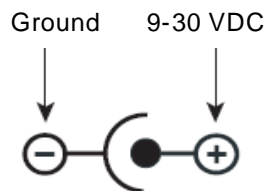

Test points

The development board provides five test points that can be identified by board label or test point number. The board labels are adjacent to each test point on the board. The test point numbers are in the development board schematic drawings.

Numbers and description

Test point	Label	Source/Comment
TP36	+12V	+Charge pump off of DC/DC regulator (U32)
TP37	-12V	- Charge pump off of DC/DC regulator (U32)
TP38	+5V	DC/DC regulator (U32) with 9-30VDC input
TP41	+3.3V	DC/DC regulator (U35) with +5V input
TP42	GND	Common Ground return

Factory default interface configuration for development board

.....

These interfaces are enabled as shown per the factory default configuration:

Interface	Factory default status
LCD VGA	Enabled
I ² C (5V tolerant)	Enabled
I ² C user-driven I/Os	Enabled
EIA-232 Serial Port A	Enabled (No DCD unless LCD_VGA is disabled)
EIA-485 Serial Port A	Disabled
EIA-232 Serial Port B	Enabled (Full modem support)
TTL Serial Port C	Disabled (Disabled when LCD_VGA is enabled)
TTL Serial Port D	Disabled (GPIO signals 44-47 default as GPIOs)
SPI Serial Port B	Disabled (No SPI unless EIA-232 Serial Port B is disabled)

LCD and USB Configuration

C H A P T E R 4

This chapter addresses module specifics pertaining to the LCD and USB interfaces.

See the application note “LCD Displays Supported by the NetSilicon NS9750/NS9360 Processors” (available on <http://www.digiembedded.com>) for additional information about the application-specific configuration and capabilities of the LCD controller on the ConnectCore 9C/Wi-9C module.

LCD displays

There are seven categories of LCD displays, all of which the module supports:

- Color TFT (*thin film transistor*, also called *active matrix (AM)*):
 - 18-bit
- Six types of STN (*super twisted nematic*, also called *passive matrix (PM)*):
 - Three single panel displays
 - Three dual panel displays

Each STN display is either color or monochrome:

- Color display: Up to 8-pin using color-enhancing palette RAM
- Monochrome display: Up to 8-pin or 4-pin using grayscale-enhancing palette RAM

Control and data pins

The ConnectCore 9C/Wi-9C LCD interface has six control pins. The number of data pins depends on the display type. Displays typically require 4–6 control pins. The next two tables list the control pins and the data pins, respectively.

LCD controller control pins

Pin #	Signal name	Type	Description
89	CLPOWER	Output	LCD panel power enable
87	CLLP (HSYNC)	Output	Line synchronization pulse (STN)/horizontal synchronization pulse (TFT)
46	CLCP	Output	LCD panel clock
44	CLFP	Output	Frame pulse (STN)/vertical synchronization pulse (TFT)
42	CLAC	Output	STN AC bias drive or TFT data enable output
38	CLLE	Output	Line end signal

LCD controller data pins

Display type	Number of data pins: Panel 1	Number of data pins: Panel 2
TFT—Color only		
Color 18-bit	18	Not applicable
STN—Color		
Single panel 8-bit	8	Not applicable
Dual panel 8-bit	8	8
STN—Monochrome		
Single panel 4-bit	4	Not applicable
Dual panel 4-bit	4	4
Single panel 8-bit	8	Not applicable
Dual panel 8-bit	8	8

Note: Double-panel displays use twice as many pins but do not offer more color or gray shades.

Colors and gray shades

The number of colors and gray shades correlates with the number of data pins but also depends on color processing techniques and data-shifting techniques.

For exact values, see the *NS9360 Hardware Reference*, LCD Controller chapter, "Number of Colors" and "Grayscale." You can access the *NS9360 Hardware Reference* through the Jump Start Kit.

Sample displays

ConnectCore 9C/Wi-9C uses an internal programmable palette-LUT and a grayscale to support different color-processing techniques; three sample displays are provided here:

- **18-pin TFT display** (for example, the SHARP LQ10D421). Accepts 18 color RGB bits (6 bits per color) at a time. Only 16 bits are transferred from SDRAM: five bits each for the three colors – R (red), G (green), and B (blue) – and a single LSB (least significant bit) that is split into three equal values between R, G, and B. This produces close to 2^{16} , or 64 thousand colors.
- **8-pin STN color display** (for example, the SHARP LM057QC1T01). Shifts eight color bits at a time: RGBRGBRG bits followed by BRGBRGBR bits followed by GBRGBRGB, and so on. This produces color enhancing in 3375 color grades.
- **4-pin STN monochrome display** (for example, the Grand Pacific Optoelectronics GM0008-13). Shifts four monochrome bits at a time, resulting in 15 gray shades ($2^4 - 1$).

Resolution

The LCD resolution is programmable. These standard displays, with the following resolutions, are supported:

- QVGA = 320 x 240
- VGA = 640 x 480

Lower resolution displays also are supported. Displays typically have programmable vertical resolutions within a certain range, especially if they are used for TV displays (to accommodate different television standards).

Refresh frequency

The LCD refresh frequency is programmable. Lower refresh frequency drains less power, but might flicker. TFT displays usually flicker less than STN displays, as they have a transistor switch behind each pixel on the screen and can hold the capacitive charge longer.

Sample applications

The LCD interface uses memory as a video buffer. The display resolution is determined by the product of three parameters: *number of data bits x display resolution x refresh frequency*. This product cannot exceed the system bus bandwidth allocated to the display.

Be aware that the actual bandwidth used by the display is:

display clock rate x number of bits per clock

For example, a clock rate of 50MHz with 16 bits of color yields a bandwidth of 100 MBps. To minimize bandwidth requirements, you might need to use an external oscillator to get the exact rate.

The ConnectCore 9C/Wi-9C development board has a 48MHz external oscillator and resulting LCD clock of 24MHz. 16 bits of color requires 48 MBps for the display.

Default LCD controller

The default LCD controller configuration supported by the NS9360 is 640 x 480, with 8 bits for color. The bandwidth is guaranteed; the designer does not need to be concerned with bandwidth use. Higher resolutions are possible but require care in their setup and design.

Formula

The ConnectCore 9C/Wi-9C module operates at 155 MHz system bus speed. This speed grade results in 310 MBps bus bandwidth, as the bus is 4 bytes wide. For bandwidth planning, this maximum bandwidth must be reduced to account for overhead and read/write switching. The effective bandwidth is 1/2 of the system bandwidth; that is, 155 MBps. This value is predicted as the worst case for the ConnectCore 9C/Wi-9C. The architecture allocates half of the system bandwidth to the module. The remaining four bus master peripherals (Ethernet TX, Ethernet RX, peripheral bus bridge, and LCD controller) share the other half of the bandwidth. The bandwidth assignment of these peripherals is programmable.

Use this formula to estimate the amount of bandwidth available for your LCD display:

CPU bandwidth = 77.5 MBps

All other peripherals (including LCD) = 77.5 MBps

Example 1: 18-bit VGA

The 18-bit TFT display transfers 16 bits per pixel and generates the last two bits inside the LCD controller. This display packs two-color RGB pixels into a single 4-byte word.

The 18-bit VGA display (640 x 480), refreshing 60 times per second, requires 37 MBps:

$$2 \times 640 \times 480 \times 60 = 37 \text{ MBps}$$

40.5 MBps are left to all other peripherals. If the LCD refresh frequency increases to 70 Hz, the required bandwidth increases to 43 MBps.

Note: The module LCD controller supports 18-bit VGA displays in most applications.

Supported TFT displays

Display type	Refresh frequency in Hz	BW required for display in MBps	Display in MBps BW left to other peripherals in MBps
18b VGA (640 x 480)	50	31	46.5
	60	37	40.5
	70	43	34.5

USB configuration

When you purchase the Ethernet plus USB hub version of the ConnectCore 9C/Wi-9C module, the USB hub is installed on the module.

On modules without USB, NS9360 dedicated USB signals are brought out to the Application header, P17:

P17 pin	Signal	Description
16	DP1	USB data (+)
17	DM1	USB data (-)
28	USB_OVRH#	USB overcurrent
29	USB_PONH#	USB power-on

See also

- “Power requirements” on page 67 for power required per USB port.
- “USB interface” on page 68 for information about integrating the module without on-board USB and without need for USB.
- “USB internal PHY DC electrical inputs and outputs” on page 77

Module Specifications

A P P E N D I X A

This appendix provides ConnectCore 9C/Wi-9C module specifications.

Mechanical dimensions

ConnectCore 9C

- Length: 3.590 inches (91.19 mm)
Add (0.136 inches (3.45 mm) for USB and/or Ethernet connector overhang
- Width: 2.055 inches (52.2 mm)
- Height:
 - 0.799 inches (20.3 mm) with Dual USB connector
 - 0.712 inches (18.08 mm) with RJ-45 Ethernet connector

ConnectCore Wi-9C

- Length: 3.590 inches (91.19 mm)
 - Add 0.136 inches (3.45 mm) for USB and/or Ethernet connector overhang
 - Add 0.375 inches (8.95 mm) for RP-SMA antenna overhang
- Width: 3.055 inches (77.60 mm)
- Height:
 - 0.799 inches (20.3 mm) with dual USB connector
 - 0.712 inches (18.08 mm) with RJ-45 Ethernet connector

Environmental information

- ConnectCore 9C**
- Operating temperature: -40° C to +85° C (-40° F to +185° F)
 - Storage temperature: -40° C to +125° C (-40° F to 257° F)
 - Relative humidity: 5% to 95% (non-condensing)
 - Altitude: 12,000 ft (3657.6 m)

- ConnectCore Wi-9C**
- Operating temperature: -30° C to +75° C (-22° F to +167° F)
 - Storage temperature: -40° C to +125° C (-40° F to 257° F)
 - Relative humidity: 5% to 95% (non-condensing)
 - Altitude: 12,000 ft (3657.6 m)

Network interface

- Ethernet**
- Standard: IEEE 802.3
 - Physical layer: 10/100Base-T
 - Data rate: 10/100 Mbps (auto-sensing)
 - Mode: Full or half duplex (auto-sensing)
 - On-board connector: RJ-45 with magnetics (optional)
 - 802.3af power pass-through (mid-span and end-span)

- WLAN**
- Standard: IEEE802.11b/g
 - Frequency: 2.4 GHz
 - Data rate: Up to 54 Mbps with fallback
 - Modulation: DBPSK (1 Mbps), DQPSK (2 Mbps), CCK (11,5.5 Mbps), BPSK (6,9 Mbps), QPSK (12,18 Mbps), 16-QAM (24,36 Mbps), 64-QAM (48,54 Mbps)
 - Transmit power: 16 dBm typical
 - Receive sensitivity: -73 dBm @ 54 Mbps
 - Connector: 1/2 x RP-SMA or 2 x U.FL



Power requirements

- ConnectCore 9C**
- Module: 3.3VDC @ 0.75A max
 - USB interface: 5VDC @ 0.5A max per port (optional)

- ConnectCore Wi-9C**
- Module: 3.3V ± 5% @ 0.95A max, 0.70A typ
 - Optional USB: 5V ± 10% @ 1.0A max

Power up The rise time of both the 3.3V power supply and 5V power supply must be between 700 μs and 140 ms, and the inrush current must be limited to less than 2A.

Real-time clock

The accuracy of the internal Real-Time Clock on the module’s processor is .15%.

I²C signals

The I²C signals are multiplexed with GPIO.

Legend

- SO-DIMM pin #: Pin number assignment for signal
- Signal: Pin name for each signal.
- U/D: Indicates whether the pin has an internal pullup resistor or pulldown resistor.
 - U — Pullup
 - D — Pulldown
 - Blank — Neither an internal pullup or pulldown resistor
- OD (mA): The output drive of an output buffer.
- I/O: Type of signal input (I), output (O), or input/output (I/O)

Signals

SO-DIMM Pin#	Signal name	GPIO	U/D	OD (mA)	I/O	Description
55	iic_scl	GPIO[34]	U	4	I/O	I ² C serial clock line. Duplicate on GPIO[70]
66	iic_sda	GPIO[35]	U	4	I/O	I ² C serial data line. Duplicate on GPIO[71]

SO-DIMM Pin#	Signal name	GPIO	U/D	OD (mA)	I/O	Description
26	iic_scl	GPIO[70]		8	I/O	I ² C serial clock line. Primary on GPIO[34]
24	iic_sda	GPIO[71]		8	I/O	I ² C serial data line. Primary on GPIO[35]

USB interface

USB Host

The USB Host consists of a USB Host controller that conforms to the Open Host Controller Interface (OHCI) specification and a wrapper to interface the module to the rest of the system. The USB Host interfaces to the internal USB PHY provided by the NS9360, and is connected to an *optional* hub on the module.)

USB Device

The USB Device module provides a USB 2.0-compliant interface for both full-speed (12Mbps) and low-speed (1.5 Mbps) operation. The module supports one bidirectional endpoint and up to 10 unidirectional endpoints that can be individually programmed for endpoint type (interrupt, bulk, or isochronous) and direction. Each endpoint is assigned to a DMA channel in a multi-channel BBus DMA controller. The USB Device module interfaces to either the internal NS9360 USB PHY or an external USB PHY using GPIO.

Support

Both USB Host and Device can be supported at the same time:

- USB Device, in this case, must use the only the signals shown in the table in the section "USB Device only," beginning on page 69.
- USB Host can be on the module or external to the module. If USB Host is external to the module, use only the signals shown in the table in the section "No USB on module," beginning on page 68.

Note: All output drivers for USB meet the standard USB driver specifications.

USB Host with hub on module

- Connect up to two ports using the dual USB connector, P6.
- All hub signals out to the SO-DIMM edge connector, P3, are reserved for future use.

No USB on module

- USB data lines are brought out on DM1 and DP1.
 - Terminate DM1 and DP1 with 15K pulldowns, if not used.
- OVR1# and PON1# are multiplexed with GPIO16 and GPIO17.

- Can be used as Host or Device (USB PHY is internal)

SO-DIMM pin #	Signal name	I/O	Description
135	DM1	I/O	USB data -
136	DP1	I/O	USB data+
109	OV RH# / gpio16	I	Overcurrent
111	PONH# / gpio17	O	Power-on

USB Device only

The USB Device interface only requires an external PHY. The USB signals are multiplexed with GPIOs.

On the Digi development board, these functions are lost:

- Serial Port D: TXDD, RXDD, RTSD#, AND CTSD# on GPIO[44], GPIO[45], GPIO[46], and GPIO[47]
- Serial Port C: RTSC# and CTSC# on GPIO[42] and GPIO[43]
- User LED3 and LED4 on GPIO[48] and GPIO[49]

SO-DIMM pin	Signal name	I/O	Description
48	DATA- / GPIO[43]	I/O	USB VM
52	DATA+ / GPIO[42]	I/O	USB VP
47	OE / GPIO[44]	O	USB OE
45	RCV / GPIO[45]	I	USB RCV
43	RXD+ / GPIO[46]	I/O	USB RXP/EMUN
41	RXD- / GPIO[47]	I	USB RXM (unidirectional only)
96	SPD / GPIO[49]	O	USB SPD
98	SUSP / GPIO[48]	O	USB SUSP

Module reset

The module reset pin is on the module SO-DIMM connector, P3 – pin 105, signal RST#.

- Active low signal.
- An ADM811S voltage supervisor is provided to reset the ConnectCore 9C module at any time the power phases out. If +3.3V power supply dips below 2.93 volts, the ADM811S asserts and holds the reset signal.

The ADM811S asserts the hard reset signal, causing the entire system to go into reset. Manual reset input is wired to ADM811S from JTAG header P2.

- The minimum pulse width for reset signal is 10 μ s.

Module / SO-DIMM signal characteristics

Note: All signal directions are referenced as into or out of the ConnectCore Wi-9C module.

I/O class details

I/O class	Class description	Minimum high-level input current source	Minimum low-level input current sink
Class 1	Standard LVTTL	10 μ A	10 μ A
Class 2	LVTTL + internal pullup	10 μ A	210 μ A
Class 3	LVTTL + internal pullup+2.4k external pulldown (strapping)	840 μ A	210 μ A
Class 4	3.3V LVC BUS HOLD LVTTL I/O	75 μ A	75 μ A

Note: For internal pullup calculations, see the *NS9360 Hardware Reference* (available through the Jump Start Kit).

Signal characteristics

Pin	Signal name	Internal U/D	OD (mA)	I/O	Description	I/O class	Notes / Bootstrapping (BS)
1	GND						
2	GND						
3	+3.3V			I			
4	+3.3V			I			
5	+3.3V			I			
6	+3.3V			I			
7	WAKEUP#			I	Wi-9C: Wakeup after sleep mode		Reserved
	PWRDWN#			I	CC9C: Power down		
8	UBUFFENR#		24	O	User buffer enable		Holds user buffers off during powerup/down and until boot is done
9	DATA_0		12	BI	Data bus signal	4	

Pin	Signal name	Internal U/D	OD (mA)	I/O	Description	I/O class	Notes / Bootstrapping (BS)
10	DATA_1		12	BI	Data bus signal	4	
11	DATA_2		12	BI	Data bus signal	4	
12	DATA_3		12	BI	Data bus signal	4	
13	DATA_4		12	BI	Data bus signal	4	
14	DATA_5		12	BI	Data bus signal	4	
15	DATA_6		12	BI	Data bus signal	4	
16	DATA_7		12	BI	Data bus signal	4	
17	ADDRESS_0		12	O	Address bus signal	4	
18	ADDRESS_1		12	O	Address bus signal	4	
19	GND						
20	GND						
21	ADDRESS_2		12	O	Address bus signal	4	
22	MFGI_GPIO[72]		8	I/O		1	
23	ADDRESS_3		12	O	Address bus signal	4	
24	GPIO[71]		8	I/O		1	
25	ADDRESS_4		12	O	Address bus signal	4	
26	GPIO[70]		8	I/O		1	
27	ADDRESS_5		12	O	Address bus signal	4	
28	GPIO[69]		8	I/O		1	
29	GND						
30	GND						
31	GPIO[27]	U	4	I/O		2	
32	No connect						
33	GPIO[26]	U	4	I/O		2	
34	GPIO[67]		8	I/O		1	
35	GPIO[25]	U	4	I/O		2	
36	GPIO[66]		8	I/O		1	
37	GPIO[24]	U	4	I/O		3	BS: Chip select 1 data width bootstrap select (Default=0, 16-bit width)
38	GPIO9230	U	4	I/O		2	
39	GND						
40	GND						
41	GPIO[47]	U	2	I/O		2	

Pin	Signal name	Internal U/D	OD (mA)	I/O	Description	I/O class	Notes / Bootstrapping (BS)
42	GPIO[22]	U	4	I/O		2	
43	GPIO[46]	U	2	I/O		2	
44	GPIO[21]	U	4	I/O		2	
45	GPIO[45]	U	2	I/O		2	
46	GPIO[20]	U	8	I/O		3	BS: Chip select 1 data width bootstrap select (Default=0, 16-bit width)
47	GPIO[44]	U	2	I/O		3	BS: Endian mode (Default=0, Big Endian)
48	GPIO[43]		2	I/O		1	
49	GND						
50	GND						
51	GPIO[38]	U	4	I/O		2	
52	GPIO[42]		2	I/O		1	
53	GPIO[36]	U	4	I/O		2	
54	GPIO[41]	U	4	I/O		2	
55	GPIO[34]	U	4	I/O		2	
56	GPIO[40]	U	4	I/O		2	
57	GPIO[32]	U	4	I/O		2	
58	GPIO[39]	U	4	I/O		2	
59	GND						
60	GND						
61	GND						
62	GND						
63	GPIO[30]	U	4	I/O		2	
64	GPIO[37]	U	4	I/O		2	
65	GPIO[28]	U	4	I/O		2	
66	GPIO[35]	U	4	I/O		2	
67	GPIO[15]	U	2	I/O		2	
68	GPIO[33]	U	4	I/O		2	
69	GPIO[14]	U	2	I/O		2	
70	GPIO[31]	U	4	I/O		2	
71	GND						
72	GND						

Pin	Signal name	Internal U/D	OD (mA)	I/O	Description	I/O class	Notes / Bootstrapping (BS)
73	GPIO[13]	U	2	I/O		2	
74	GPIO[29]	U	2	I/O		2	
75	GPIO[12]	U	2	I/O		3	BS: PLL_ND[3] (Default=0, PLL multiplier)
76	GPIO[07]	U	2	I/O		2	
77	GPIO[11]	U	2	I/O		2	
78	GPIO[06]	U	2	I/O		2	
79	GPIO[10]	U	2	I/O		3	BS: PLL_ND[2] (Default=0, PLL multiplier)
80	GPIO[05]	U	2	I/O		2	
81	GND						
82	GND						
83	GPIO[09]	U	2	I/O		2	
84	GPIO[04]	U	2	I/O		2	BS: PLL_ND[4] (Default=1, PLL multiplier)
85	GPIO[08]	U	2	I/O		3	BS: PLL_ND[1] (Default=0, PLL multiplier)
86	GPIO[03]	U	2	I/O		2	
87	GPIO[19]	U	4	I/O		2	BS: PLL_BYN (This pin must not be pulled to logic 0 during Boot)
88	GPIO[02]	U	2	I/O		3	BS: PLL_FS[0] (Default=0, PLL frequency divide by 1)
89	GPIO[18]	U	4	I/O		2	
90	GPIO[01]	U	2	I/O		2	
91	OE#		24	O	Output enable		
92	GPIO[00]	U	2	I/O		3	BS: PLL_FS[0] (Default=0, PLL frequency divide by 1)
93	GND						
94	GND						
95	WE#		24	O	Write enable		
96	GPIO[49]	U	2	I/O		2	BS: CS_POL (Chip select polarity, 0=Active high, 1=Active low)
97	CS#		24	O	Chip select		
98	GPIO[48]	U	2	I/O		2	
99	TXB+R			I/O	Remote Ethernet TX B+		
100	TXA+R			I/O	Remote Ethernet TX A+		

Pin	Signal name	Internal U/D	OD (mA)	I/O	Description	I/O class	Notes / Bootstrapping (BS)
101	GND						
102	GND						
103	TXB-R			I/O	Remote Ethernet TX B-		
104	TXA-R			I/O	Remote Ethernet TX A-		
105	MODRST#			I	Reset	1	
106	ACT_LED#			I	PHY activity LED		
107	BOOTMUXR#			O	Boot mux		
108	LNK_LED			I	PHY link LED		
109	GPIO[16]	U	2	I/O		2	
110	ADDRESS_6		12	O	Address bus signal	4	
111	GPIO[17]	U	2	I/O		2	BS: PLL_ND[4] (Default=1, PLL multiplier)
112	ADDRESS_7		12	O	Address bus signal	4	
113	OVR3#			I	USB over-current 3		
114	OVR4#			I	USB over-current 4		
115	PON3#		4	O	USB power-on 3		
116	PON4#		4	O	USB power-on 4		
117	OVR1#			I	USB over-current 1		
118	OVR2#			I	USB over-current 2		
119	PON1#		4	O	USB power-on 1		
120	PON2#		4	O	USB power-on 2		
121	GND						
122	GND						
123	DM4			I/O	USB data-		
124	DP4			I/O	USB data+		
125	GND						
126	GND						
127	DM3			I/O	USB data-		
128	DP3			I/O	USB data+		
129	GND						
130	GND						
131	DM2			I/O	USB data-		
132	DP2			I/O	USB data+		

Pin	Signal name	Internal U/D	OD (mA)	I/O	Description	I/O class	Notes / Bootstrapping (BS)
133	GND						
134	GND						
135	DM1			I/O	USB data-		
136	DP1			I/O	USB data+		
137	GND						
138	GND						
139	+5V			I			
140	+5V			I			
141	+5V			I			
142	+5V			I			
143	GND						
144	GND						

Electrical characteristics

The ConnectCore 9C/Wi-9C operates at a 3.3V with an additional 5V supply for USB device power.

Absolute maximum ratings

Permanent device damage can occur if the absolute maximum ratings are ever exceeded.

Parameter	Symbol†	Rating	Unit
DC supply voltage	V_{DDA}	-0.3 to +3.6	V
DC input voltage	V_{INA}	-0.3 to $V_{DDA}+0.3$	V
DC output voltage	V_{OUTA}	-0.3 to $V_{DDA}+0.3$	V
DC input current	I_{IN}	±10	mA
Storage temperature	T_{STG}	-40 to +125	°C

† V_{DDA} , V_{INA} , V_{OUTA} : Ratings of I/O cells for 3.3V interface

Recommended operating conditions

Recommended operating conditions specify voltage and temperature ranges over which a circuit's correct logic function is guaranteed. The specified DC electrical characteristics (see "DC electrical characteristics," beginning on page 76) are satisfied over these ranges.

For operating temperatures, see "Environmental information" on page 66.

Parameter	Symbol	Rating	Unit
DC supply	+3.3V	+3.0 to +3.6	V
USB DC supply (modules with USB only)	+5V	+4.75 to +5.25	V

Power dissipation

The *typical power dissipation* for the ConnectCore 9C module is 1.6W.

The *typical power dissipation* for the ConnectCore Wi-9C module at 3.3V, is 2.75W.

The *maximum* power dissipation is 3.25W at 3.46V, when the radio is continuously transmitting. Note that these values do not include USB power.

DC electrical characteristics

DC characteristics specify the worst-case DC electrical performance of the I/O buffers that are guaranteed over the specified temperature range.

Inputs

All electrical inputs are 3.3V interface.

Note: $V_{SS} = 0V$ (GND)

Sym	Parameter	Condition	Value	Unit
V_{IH}	High-level input voltage: LVTTL level		Min 2.0	V
V_{IL}	Low-level input voltage: LVTTL level		Max 0.8	V
I_{IH}	High level input current (no pulldown)	$V_{INA}=V_{DDA}$	Min/Max -10/10	μA
	Input buffer with pulldown		Min/Max 10/200	μA
I_{IL}	Low-level input current (no pullup)	$V_{INA}=V_{SS}$	Min/Max -10/10	μA
	Input buffer with pullup		Min/Max 10/200	μA
I_{OZ}	High-impedance leakage current	$V_{OUTA}=V_{DDA}$ or V_{SS}	Min/Max -10/10	μA
I_{DDS}	Quiescent supply current	$V_{INA}=V_{DDA}$ or V_{SS}	Max TBD	

Outputs

All electrical outputs are 3.3V interface.

Sym	Parameter	Value	Unit
V_{OH}	High-level output voltage (LVTTL)	Min $V_{DDA}-0.6$	V
V_{OL}	Low-level output voltage (LVTTL)	Max 0.4	V

USB internal PHY DC electrical inputs and outputs

The USB internal PHY DC electrical inputs and outputs are used only when there is no USB configuration on the module.

USB internal PHY DC electrical inputs

Symbol	Parameter	Min	Max	Units	Notes
V _{IH}	Input high level (driven)	2.0		V	
V _{IZ}	Input high level (floating)	2.7	3.6	V	
V _{IL}	Input low level		0.8	V	
V _{DI}	Differential input sensitivity	0.2		V	1
V _{CM}	Differential common mode range	0.8	2.5	V	2

Notes:

- 1 | (usb_dp) - (usb_dm) |
- 2 Includes V_{DI} range.

USB internal PHY DC electrical outputs

Symbol	Parameter	Min	Max	Units	Notes
V _{OL}	Output low level	0.0	0.3	V	1
V _{OH}	Output high level	2.8	3.6	V	2
V _{CRS}	Output signal crossover voltage	1.3	2.0	V	3

Notes:

- 1 Measured with R_L of 1.425k ohm to 3.6V.
- 2 Measured with R_L of 14.25k ohm to GND.
- 3 Excluding the first transition from the idle state.

Antenna information

The ConnectCore Wi-9C module provides use of one of these antenna types:

- 2 dBi Dipole
- 5 dBi Dipole
- 2 dBi PCB mount

Be sure that your antenna choice complies with the regulatory requirements of your region. In North America, for example, you can operate only with antennas

approved by Digi International, Inc., or antennas matching the specifications of the Digi-approved antennas.

Antenna specifications — 2 dBi Dipole

Attributes

Antenna Attribute	2 dBi Dipole
Frequency	2.4 ~ 2.5GHz
Power output	2W
DB gain	2 dBi
VSWR	< or = 2.0
Dimension	108.5 mm x 10.0 mm
Weight	10.5g
Connector	RP-SMA
Temperature rating	-40 – +80C
Part number	DC-ANT-20DP-BG

Dimensions

Note: Dimensions are provided for reference purposes only. The actual antenna might vary.

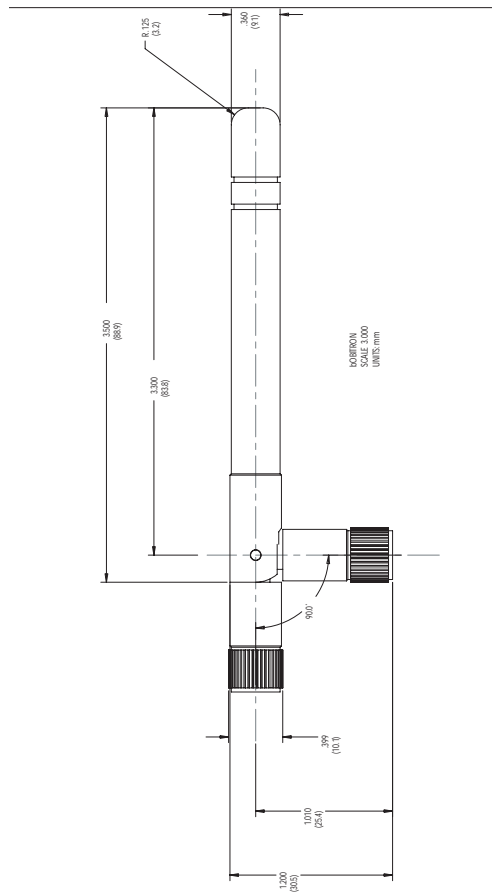

Antenna strength (radiation pattern) diagram

This diagram shows the strength of the signal received by the whip antenna on both a horizontal and vertical plane. The diagram shows the magnetic field when the antenna is in a vertical position. The red solid line represents the horizontal plane and the green dotted line represents the vertical plane. You can see in the illustration that at 90 degrees, the signal strength is 0 (as expected).

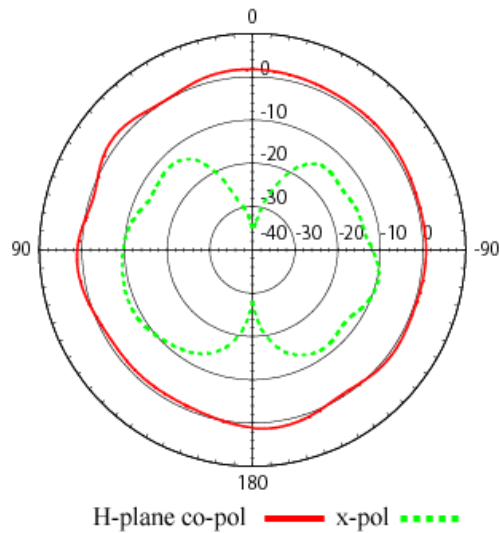

Antenna specifications — 5 dBi Dipole

Attributes

Antenna Attribute	Band 1	Band 2
Frequency	2.4 ~ 2.5GHz	5.15~5.35 GHz 5.725~5.85 GHz
Power output	1W	
DB gain	5 dBi (typ)	
VSWR	2.0 max	
Dimension	See the measurements in the drawing after the table	
Weight		
Connector	RP-SMA	
Temperature rating	-50 – +80C	
Part number	DG-ANT-55DP-AG	

Dimensions (in mm)

Note: Dimensions are provided for reference purposes only. The actual antenna might vary.

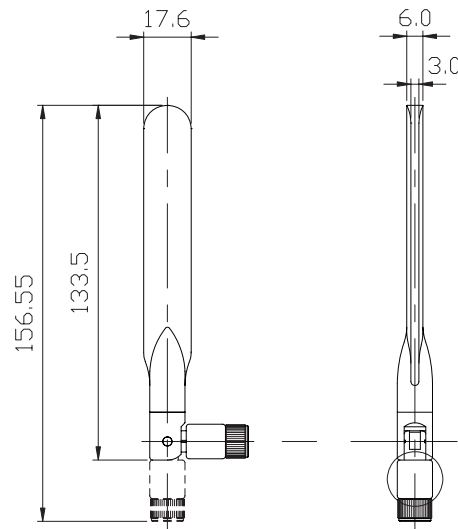

**Radiation
 pattern: H-Plane
 (2.0 and 5.0 GHz)**

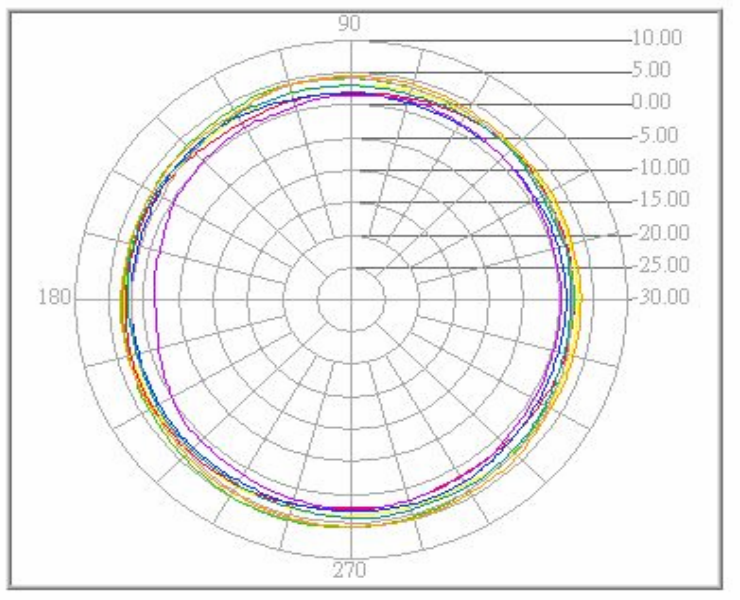

Color	Freq (MHz)	Peak (dBi)	Angle (o)	Avg (dBi)
Yellow	2400.0	3.39	257.68	2.98
Red	2450.00	3.17	214.74	2.37
Blue	2500.00	2.79	288.0	1.96
Purple	5150.00	2.25	280.42	0.82
Green	5200.00	5.23	252.63	2.71
Light brown	5250.00	4.51	272.84	3.16

MODULE SPECIFICATIONS

Antenna specifications — 2 dBi PCB mount

Color	Freq (MHz)	Peak (dBi)	Angle (o)	Avg (dBi)
Orange	5750.00	5.03	267.79	3.88
Aqua	5850.00	3.83	276.63	2.74

**Radiation
pattern: E-plane
(2.0 and 5.0 GHz)**

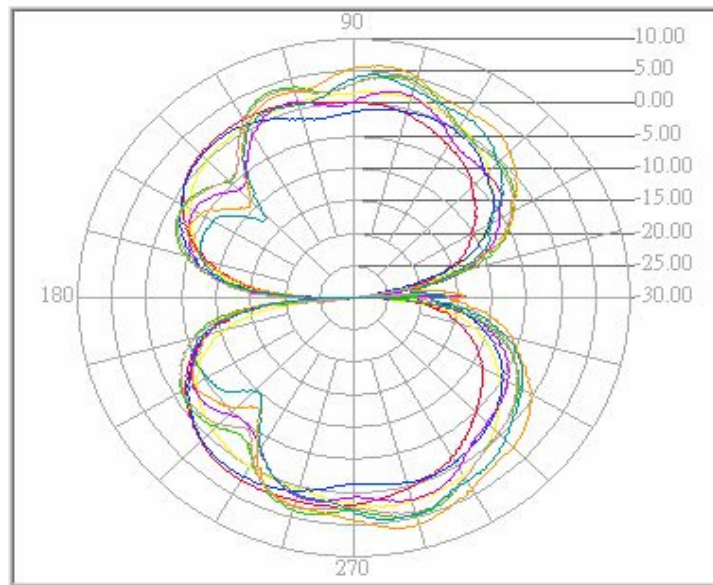

Color	Freq (MHz)	Peak (dBi)	Angle (o)	Avg (dBi)
Yellow	2400.0	2.60	283.22	-1.10
Red	2450.00	2.57	240.42	-1.36
Blue	2500.00	1.92	237.27	-1.78
Purple	5150.00	2.37	78.67	-1.91
Green	5200.00	4.80	79.30	0.32
Light brown	5250.00	4.49	79.93	-0.01
Orange	5750.00	6.34	283.85	1.08
Aqua	5850.00	4.67	283.22	-0.46

Antenna specifications — 2 dBi PCB mount

The 2dBi PCB antenna is a surface-mount dual-band antenna.

Attributes

Antenna Attribute	Band 1	Band 2
Frequency	2.4 ~ 2.5GHz	4.9 ~ 5.9GHz
Power output	10W	
DB gain	>2 dBi	
VSWR	<2.5	
Dimension	24.13 x 10.67 mm	
Weight	<1g	
Connector	U.FL	
Temperature rating	-40 – +85C	
Part number	DG-ANT-20CG-AG	

Radiation patterns

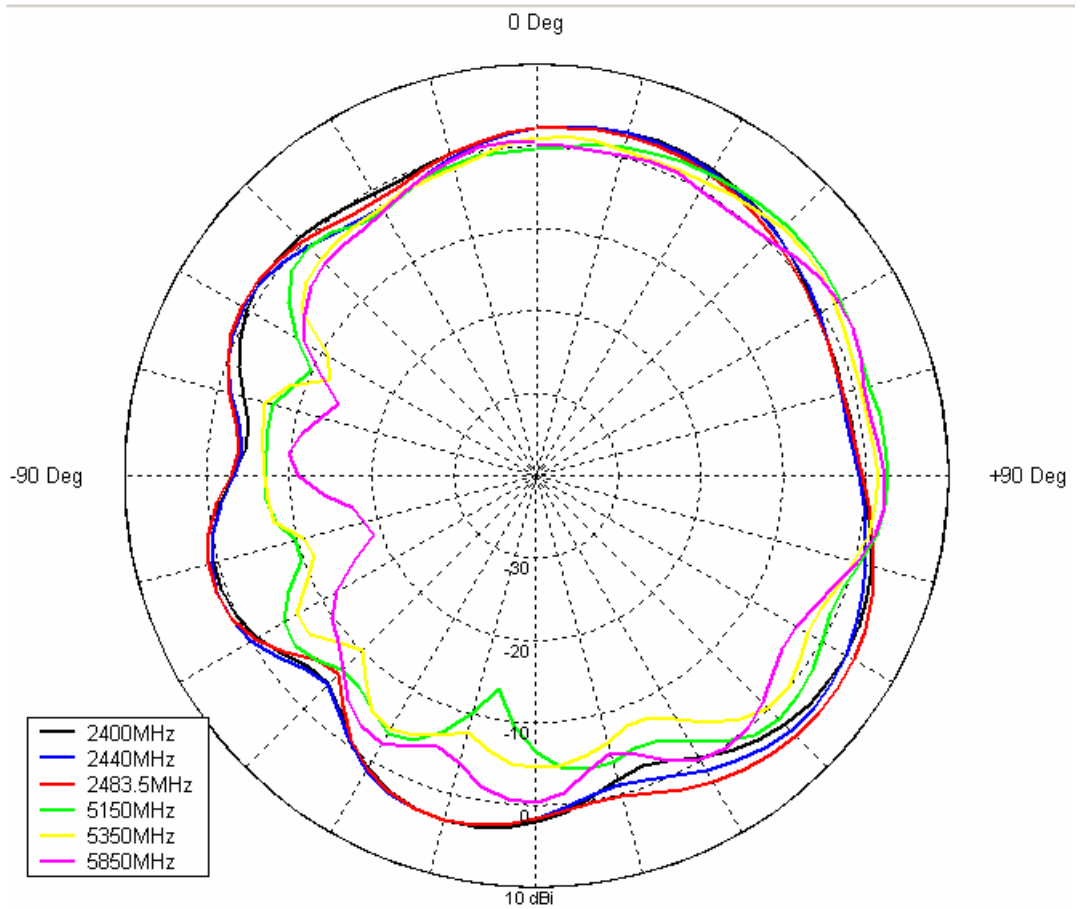

Color	Frequency	Mean gain	Peak gain
Black	2400	0.70	3.49
Blue	2440	0.73	3.99
Red	2484	1.04	4.76
Green	5150	-1.51	3.03
Yellow	5350	-2.29	2.47
Pink	5850	-2.23	2.51
n/a	Average	-0.85	2.02

FCC RF radiation exposure statement

This equipment complies with FCC radiation exposure limits set forth for an uncontrolled environment. The antenna(s) used for this transmitter must be installed to provide a separation distance of at least 20 cm from all persons and must not be co-located or operating in conjunction with any other antenna or transmitter. End users must follow the specific operating instructions for satisfying RF exposure compliance. This transmitter must not be co-located or operating in conjunction with any other antenna or transmitter.

Safety statements

To avoid contact with electrical current:

- Never install electrical wiring during an electrical storm.
- Never install an Ethernet connection in wet locations unless that connector is specifically designed for wet locations.
- Use caution when installing or modifying Ethernet lines.
- Use a screwdriver and other tools with insulated handles.
- You and those around you should wear safety glasses or goggles.
- Do not place Ethernet wiring or connections in any conduit, outlet or junction box containing electrical wiring.
- Installation of inside wiring may bring you close to electrical wire, conduit, terminals and other electrical facilities. Extreme caution must be used to avoid electrical shock from such facilities. You must avoid contact with all such facilities.

- Ethernet wiring must be at least 6 feet from bare power wiring or lightning rods and associated wires, and at least 6 inches from other wire (antenna wires, doorbell wires, wires from transformers to neon signs), steam or hot water pipes, and heating ducts.
- Do not place an Ethernet connection where it would allow a person to use an Ethernet device while in a bathtub, shower, swimming pool, or similar hazardous location.
- Protectors and grounding wire placed by the service provider must not be connected to, removed, or modified by the customer.
- Do not touch uninsulated Ethernet wiring if lightning is likely!
- Do not touch or move the antenna(s) while the unit is transmitting or receiving.
- Do not hold any component containing a radio such that the antenna is very close to or touching any exposed parts of the body, especially the face or eyes, while transmitting.
- Do not operate a portable transmitter near unshielded blasting caps or in an explosive environment unless it is a type especially qualified for such use.

Any *external* communications wiring you may install needs to be constructed to all relevant electrical codes. In the United States this is the National Electrical Code Article 800. Contact a licensed electrician for details.

Dimensions and PCB Layouts

A P P E N D I X B

This appendix shows the dimensions of each module, as well as PCB (printed circuit board) layouts of each.

Module dimensions

The next figures show the dimensions of the ConnectCore 9C/Wi-9C module. Dimensions are in inches and millimeters (millimeter size is in brackets []).

These are the tolerances for the drawings shown in this section:

Measure	Tolerance
.XX	$\pm .02$
.XXX	$\pm .010$
Angles	± 2 degrees

Overall view

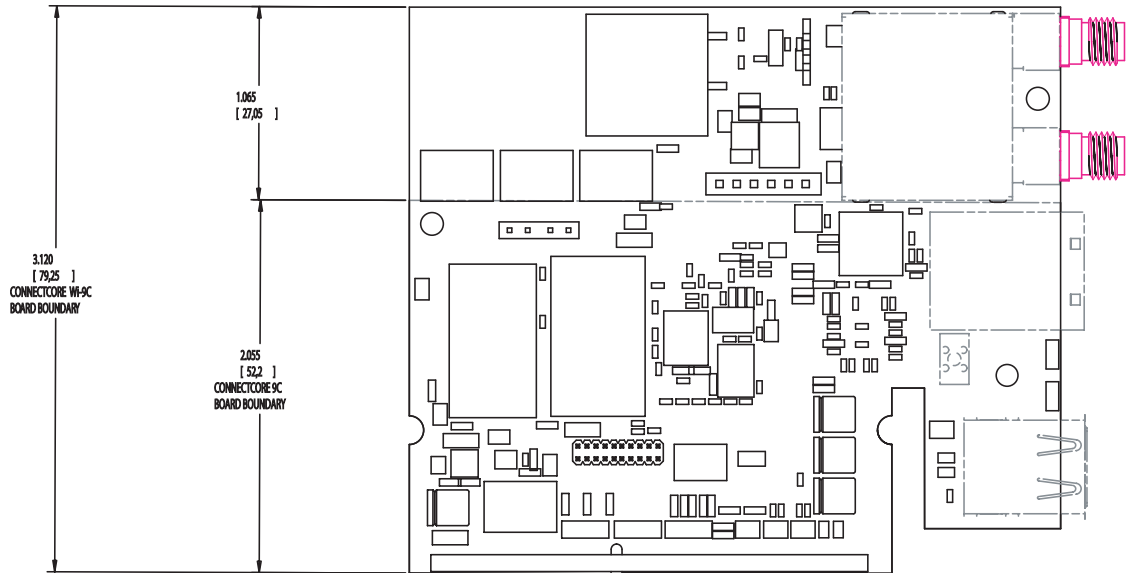

Detailed views:
Top

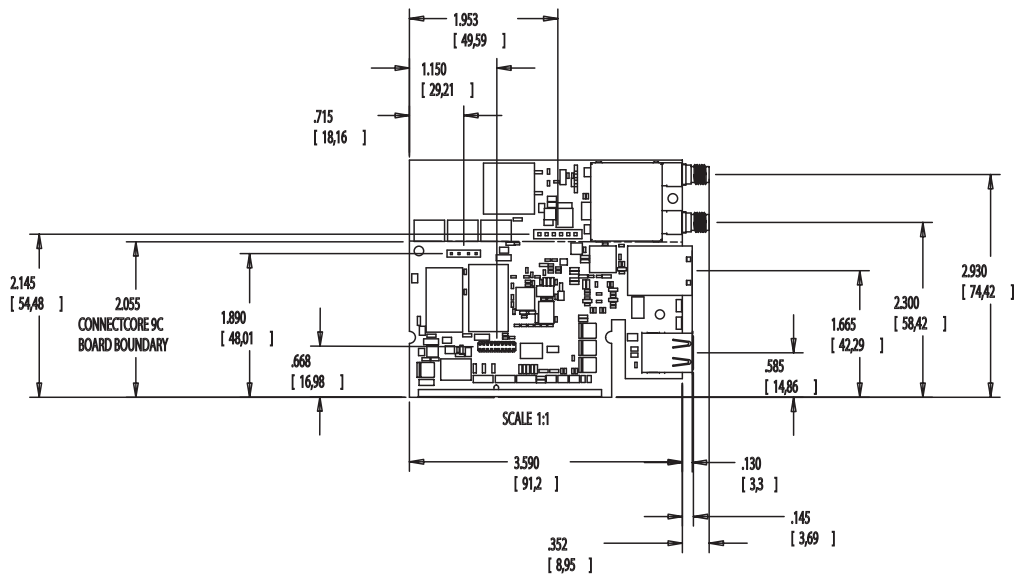



**Detailed views:
Side**

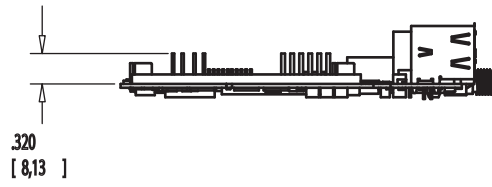

**Detailed views:
End**

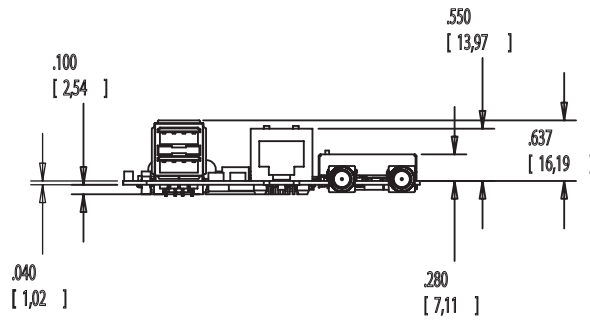

**Detailed views:
Bottom**

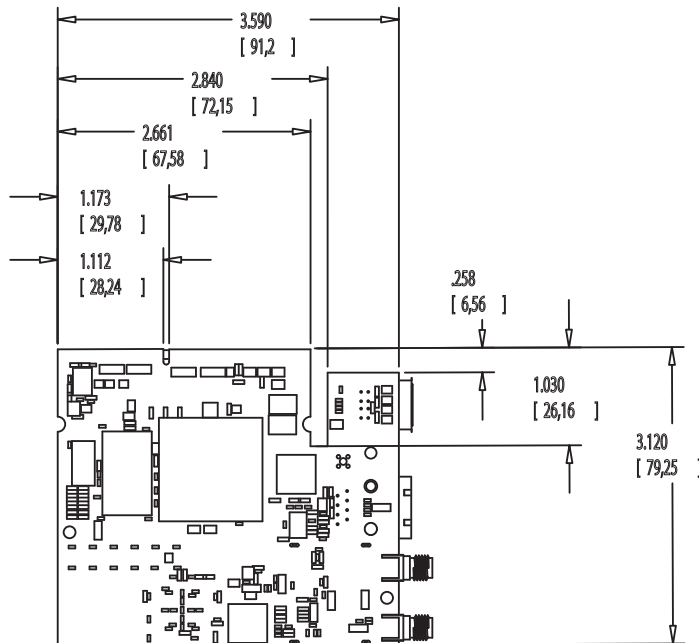

PCB layout

The next figures show the PCB layout of the ConnectCore 9C/Wi-9C module.

Overall view

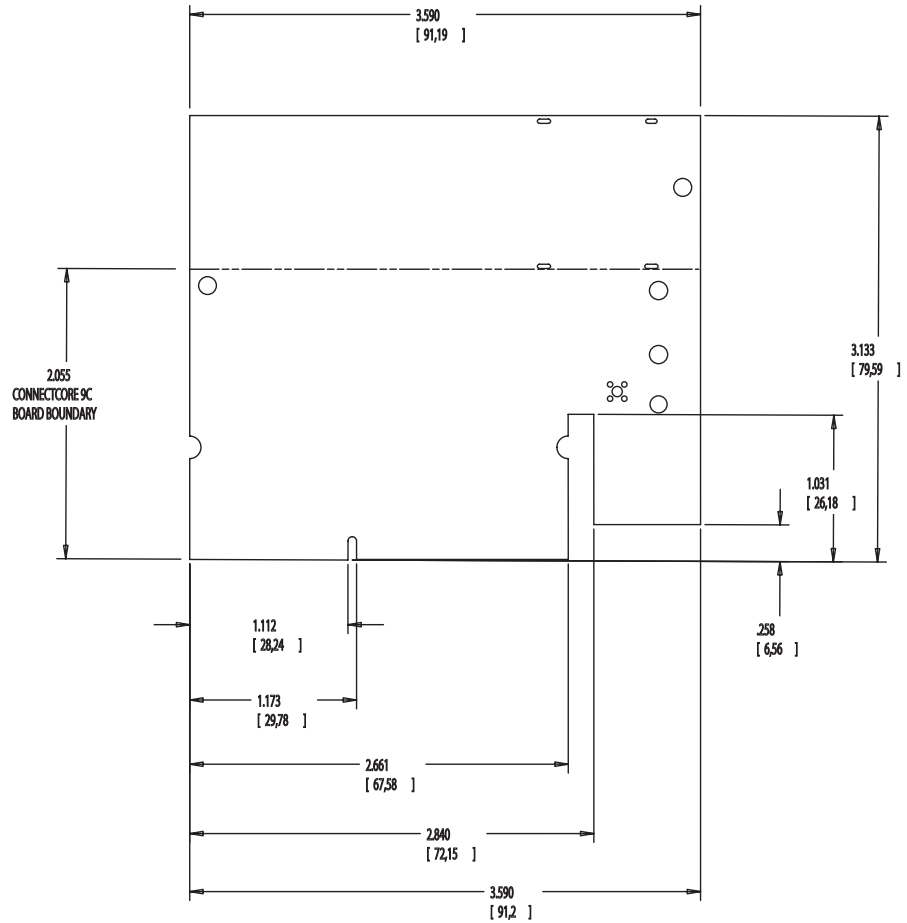

View with detail

This figure shows the view with detail for the areas marked Detail A and Detail B.

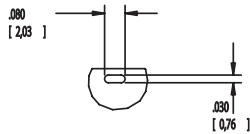
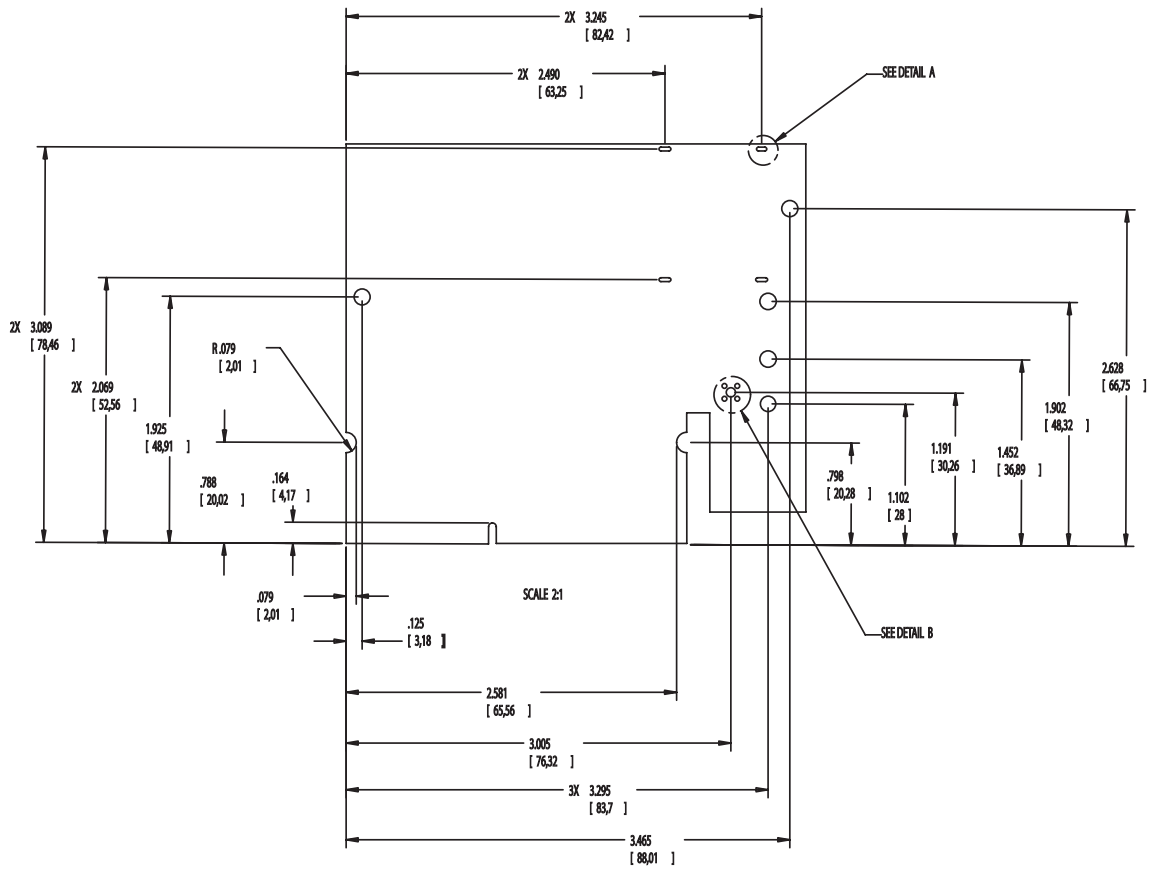

DETAIL A

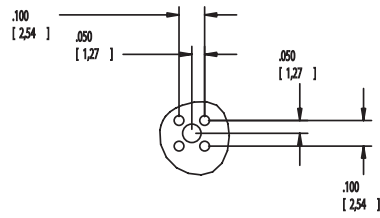

DETAIL B

Certifications

A P P E N D I X C

The ConnectCore 9C and ConnectCore Wi-9C products comply with the standards cited in this section.

FCC Part 15 Class B

Radio Frequency Interface (RFI) (FCC 15.105)

The ConnectCore 9C and ConnectCore Wi-9C embedded modules have been tested and found to comply with the limits for Class B digital devices pursuant to Part 15 Subpart B, of the FCC rules. These limits are designed to provide reasonable protection against harmful interference in a residential environment. This equipment generates, uses, and can radiate radio frequency energy, and if not installed and used in accordance with the instruction manual, may cause harmful interference to radio communications. However, there is no guarantee that interference will not occur in a particular installation. If this equipment does cause harmful interference to radio or television reception, which can be determined by turning the equipment off and on, the user is encouraged to try and correct the interference by one or more of the following measures:

- Reorient or relocate the receiving antenna.
- Increase the separation between the equipment and receiver.
- Connect the equipment into an outlet on a circuit different from that to which the receiver is connected.
- Consult the dealer or an experienced radio/TV technician for help.

Labeling Requirements (FCC 15.19)

This device complies with Part 15 of FCC rules. Operation is subject to the following two conditions: (1) this device may not cause harmful interference, and (2) this device must accept any interference received, including interference that may cause undesired operation.

If the FCC ID is not visible when installed inside another device, then the outside of the device into which the module is installed must also display a label referring to the enclosed module FCC ID. This exterior label can use wording such as the following: "Contains Transmitter Module FCC ID: MCQ-50M1355/ IC: 1846A-50M1355".

Modifications (FCC 15.21)

Changes or modifications to this equipment not expressly approved by Digi may void the user's authority to operate this equipment.

Industry Canada

This digital apparatus does not exceed the Class B limits for radio noise emissions from digital apparatus set out in the Radio Interference Regulations of the Canadian Department of Communications.

Le present appareil numerique n'emet pas de bruits radioelectriques depassant les limites applicables aux appareils numeriques de la class B prescrites dans le Reglement sur le brouillage radioelectrique edicte par le ministere des Communications du Canada.



Declaration of Conformity

(In accordance with FCC Dockets 96-208 and 95-19)

Manufacturer's Name: Digi International
Corporate Headquarters: 11001 Bren Road East
Minnetonka MN 55343
Manufacturing Headquarters: 10000 West 76th Street
Eden Prairie MN 55344

Digi International declares, that the product:

Product Name: ConnectCore 9C
Model Numbers: 50001327-xx
Product Name: ConnectCore Wi-9C
Model Numbers: 50001355-xx

to which this declaration relates, meets the requirements specified by the Federal Communications Commission as detailed in the following specifications:

- Part 15, Subpart B, for Class B equipment
- FCC Docket 96-208 as it applies to Class B personal
- Personal computers and peripherals

The product listed above has been tested at an External Test Laboratory certified per FCC rules and has been found to meet the FCC, Part 15, Class B, Emission Limits. Documentation is on file and available from the Digi International Homologation Department.

International EMC Standards

The ConnectCore 9C and ConnectCore Wi-9C meet the following standards:

Standards	ConnectCore 9C	ConnectCore Wi-9C
Emissions	AS/NZS 3548	AS/NZS 3548 CISPR 22
		FCC Part 15 Subpart C (FCC ID: MCQ-50M1355)
		IC RSS 210 (IC:1846A-50M1355)
Immunity		FCC Part 15 Subpart B
Safety		ICES-003
		EN 55022
		EN 61000-4-2
		EN 61000-4-3
		EN 61000-4-6
		EN 301 489-3
		EN 300 328
		VCCI
		EN 55024
		UL 60950-1
		CSA C22.2, No. 60950-1
		EN60950

Index

Numerics

- 802.3af Power over Ethernet (PoE) connector, P20. See *Power over Ethernet (PoE) connector, P20 (dev board)*
- 802.3af Power over Ethernet (PoE) pass-through connector, P5. See *Power over Ethernet (PoE) pass-through connector, P5 (module)*.
- 9-30VDC power input 30

A

- absolute maximum ratings 75
- antenna connectors 26–27
- antenna information 77–84
- antenna specifications
 - 2 dBi Dipole 78
 - 2 dBi PCB mount 82
 - 5 dBi Dipole 80
- application-specific expansion connectors 29, 43

B

- board and module mounting holes 30
- buttons and switches 31

C

- certifications 93
- CMO. See *current measurement option*.
- colors and gray shades (LCD) 60
- configurations
 - ConnectCore 9C 5
 - ConnectCore Wi-9C 7
- ConnectCore 9C

- about 1–9
- configurations 5
- environmental information 66
- features 1
- mechanical dimensions 65
- power requirements 67
- ConnectCore Wi-9C
 - about 1–9
 - antenna connectors 26–27
 - configurations 7
 - environmental information 66
 - features 1
 - mechanical dimensions 65
 - power requirements 67
 - RP-SMA connectors 27
 - security standards 2
 - U.FL connectors 27
 - WLAN 3
 - WLAN interface 2
- ConnectCore Wi-9C antenna options 2
- control and data pins (LCD) 59
- CR1 14
- CR2 14
- CR3 and CR5, power LEDs 54
- CR6 and CR7, user LEDs 54
- current measurement option (CMO) 30, 55

D

- daughter cards 43
- DC electrical characteristics 76
- development board 29–58
 - 9-30VDC power input 30
 - application-specific expansion connectors 29
 - board and module mounting holes 30

current measurement option 30, 55
 description 30
 digital I/O connector, P19 49
 digital I/Os VGA interface 29
 external LCD clock, G1 40
 features 29
 hardware reset switch, SW6 32
 I2C header connector, P8 33
 I2C interface 29
 LCD connectors 29
 LEDs 29, 54–55
 P16, peripheral board header 43, 44
 P17, platform application header 43, 45
 P18, LCD application header 46
 P30, PoE connector 51
 P31, PoE connector 51
 P32, USB Device application header 48
 power jack, P12 57
 power on/off switch 30
 Power over Ethernet(PoE) connector,
 P20 51
 power switch, SW5 32
 pushbuttons, SW3 and SW4 29, 32
 serial port A connector, P13 35
 serial port B connector, P9 36
 serial port C connector, P10 37
 serial port connectors 35–38
 serial port D connector, P11 37
 serial ports 29
 SO-DIMM connector, P15 40–42
 SPI header connector, P7 34
 SPI interface 29
 SW1, Serial Port A switch 31
 SW2, Serial Port B switch 32
 SW7, VGA (enable) switch 32
 test points 29, 57
 through-hole prototyping (wrap-field) area,
 P3 and P4 52
 VGA connector, P6 39
 VGA interface 29
 digital I/O connector, P19 49

E

edge connector, P3 18

electrical characteristics 75
 environmental information
 ConnectCore 9C module 66
 ConnectCore Wi-9C 66
 Ethernet connector 12–13
 connector pins 12
 LEDs 12
 Ethernet interface 2
 Ethernet with LEDs 12
 external LCD clock, G1 40
 external memory bus 4

F

factory default interface configuration 58

G

G1, external LCD clock 40

H

hardware reset switch, SW6 32

I

I2C header connector 33
 I2C interface 4, 29
 I2C signals 67
 interfaces
 Ethernet 2
 external memory bus 4
 I2C 4, 29
 LCD controller 4
 serial port 4, 35–38
 SPI 29
 USB Host/Device 3
 VGA 29
 WLAN 3

J

JTAG 20-pin header connector, P2 15



JTAG adapter 16
assembly 17

L

LCD application header, P18 46
LCD connectors 29
LCD controller
 interface 4
 number of colors 60
LCD displays 59–62
LCD refresh frequency 61
LCD resolution 61
LEDs 12
 development board 54–55
 power 54
 serial 54
 user 54
LEDs (user) 29

M

mechanical dimensions
 ConnectCore 9C module 65
 ConnectCore Wi-9C 65
memory 2
memory clocks 2
module 13
 antenna connectors 26–27
 edge connector, P3 18
 Ethernet connector 12–13
 JTAG header connector, P2 15
 LEDs, CR1 and CR2 14
 USB Host connector, P6 18
module dimensions 87–89
module layout 11
module LEDs, CR1 and CR2 14
module reset 69
module specifications 65–85

N

network interface
 Ethernet 66

WLAN 66

P

P10, serial port C connector 37
P11, serial port D connector 37
P12, power jack 57
P13, serial port A connector 35
P15, SO-DIMM connector (development board) 40–42
P16, peripheral board header 43, 44
P17, platform application header 43, 45
P18, LCD application header 46
P19, digital I/O connector 49
P2, JTAG 20-pin header connector 15
P20, Power over Ethernet (PoE) connector (dev board) 51
P3 and P4, through-hole prototyping (wrap-field) area (dev board) 52
P3, edge connector (module) 18
P30, PoE connector 51
P31, PoE connector 51
P32, USB Device application header 48
P5, Power over Ethernet (PoE) pass-through connector (module) 13
P6, USB Host connector (module) 18
P6, VGA connector (dev board) 39
P7, SPI header connector 34
P8, I2C header connector 33
P9, serial port B connector 36
PCB layouts 90–91
peripheral board header, P16 43, 44
platform application header, P17 43, 45
PoE connector, P30 51
PoE connector, P31 51
PoE support 13
power dissipation 76
power jack, P12 57
power LEDs 54
power on/off switch 30
Power over Ethernet (PoE) connector, P20 51
Power over Ethernet (PoE) pass-through connector, P5 13
Power over Ethernet (PoE) connectors 50
power requirements

- ConnectCore 9C 67
- ConnectCore Wi-9C 67
- power switch, SW5 32
- power up 67
- pushbuttons (user) 29

R

- real-time clock 67
- recommended operating conditions 75
- RF exposure statement 84
- RP-SMA connectors 27
 - primary, P10 27
 - secondary, P8 27

S

- safety statements 84
- sample applications (LCD) 61
- serial LEDs 54
- serial port A (EIA-232/422/485) interface 35
- serial port A connector 35
- Serial Port A switch, SW1 31
- serial port B (EIA-232) interface 36
- serial port B connector 36
- Serial Port B switch, SW2 32
- serial port C connector 37
- serial port C interface 37
- serial port connectors 35–38
- serial port D connector 37
- serial port D interface 37
- serial port interface 4
- serial ports 29
- SO-DIMM connector, P15 40–42
 - inserting 41
 - pin assignment 42
 - pin orientation 43
- SPI header connector 34
- SPI interface 29
- SW1, Serial Port A switch 31
- SW2, Serial Port B switch 32
- SW3, USER_PUSH_BUTTON_1 32
- SW4, USER_PUSH_BUTTON_2 32
- SW5, power switch 32

- SW6, hardware reset switch 32
- SW7, VGA (enable) switch 32
- switches
 - SW1, Serial Port A 31
 - SW2, Serial Port B 32
 - SW3 and SW4, user-programmable pushbuttons 32
 - SW5, power 32
 - SW6, hardware reset 32
 - SW7, VGA (enable) 32
- switches and buttons 31
- system clocks 2

T

- test points 29, 57
- through-hole prototyping (wrap-field) area, P3 and P4 52
- through-hole signal rail, P3 52

U

- U.FL connectors 27
 - primary, P11 27
 - secondary, P9 27
- USB configuration 63
- USB Device application header, P32 48
- USB Host and Device interface 3
- USB Host connector, P6 (module) 18
- USB interface 68–69
 - no USB on module 68
 - USB Device only 69
 - USB Host with hub on module 68
 - USB Host/Device 68
- USB internal PHY DC electrical characteristics 77
- user LEDs 54
- user pushbuttons 32

V

- VGA (enable) switch, SW7 32
- VGA connector, P6 (dev board) 39
- VGA interface 29



W

WLAN 3

wrap-field area, P4 53

