

# APPENDIX 1

## SAR Measurement Data

## Table of Contents

<b>EXHIBIT 1. SAR MEASUREMENTS RESULTS .....</b>	<b>3</b>
<b>EXHIBIT 2. ZIGBEE BODY MEASUREMENTS.....</b>	<b>5</b>
FILE NAME: DIGI-194Q 2405 MHZ ZIGBEE BODY D 5MM VERTICAL FRONT.DA52:0 .....	5
FILE NAME: DIGI-194Q 2440 MHZ ZIGBEE BODY D 5MM VERTICAL FRONT.DA52:0 .....	6
FILE NAME: DIGI-194Q 2480 MHZ ZIGBEE BODY D 5MM VERTICAL FRONT.DA52:0 .....	7
FILE NAME: DIGI-194Q 2405 MHZ ZIGBEE BODY D 5MM VERTICAL BACK.DA52:0 .....	8
FILE NAME: DIGI-194Q 2440 MHZ ZIGBEE BODY D 5MM VERTICAL BACK.DA52:0 .....	9
FILE NAME: DIGI-194Q 2480 MHZ ZIGBEE BODY D 5MM VERTICAL BACK.DA52:0 .....	10
FILE NAME: DIGI-194Q 2405 MHZ ZIGBEE BODY D 5MM HORIZONTAL UP.DA52:0 .....	11
FILE NAME: DIGI-194Q 2440 MHZ ZIGBEE BODY D 5MM HORIZONTAL UP.DA52:0 .....	12
FILE NAME: DIGI-194Q 2480 MHZ ZIGBEE BODY D 5MM HORIZONTAL UP.DA52:0 .....	13
FILE NAME: DIGI-194Q 2405 MHZ ZIGBEE BODY D 5MM HORIZONTAL DOWN.DA52:0 .....	14
FILE NAME: DIGI-194Q 2440 MHZ ZIGBEE BODY D 5MM HORIZONTAL DOWN.DA52:0 .....	15
FILE NAME: DIGI-194Q 2480 MHZ ZIGBEE BODY D 5MM HORIZONTAL DOWN.DA52:0 .....	16
FILE NAME: DIGI-194Q 2405 MHZ ZIGBEE BODY D 5MM TIP MODE.DA52:0 .....	17
FILE NAME: DIGI-194Q 2440 MHZ ZIGBEE BODY D 5MM TIP MODE.DA52:0 .....	18
FILE NAME: DIGI-194Q 2480 MHZ ZIGBEE BODY D 5MM TIP MODE.DA52:0 .....	19
<b>EXHIBIT 3. BLE (1 MBPS) BODY MEASUREMENTS .....</b>	<b>20</b>
FILE NAME: DIGI-194Q 2402 MHZ BLE BODY D 5MM VERTICAL FRONT.DA52:0 .....	20
FILE NAME: DIGI-194Q 2440 MHZ BLE BODY D 5MM VERTICAL FRONT.DA52:0 .....	21
FILE NAME: DIGI-194Q 2480 MHZ BLE BODY D 5MM VERTICAL FRONT.DA52:0 .....	22
FILE NAME: DIGI-194Q 2402 MHZ BLE BODY D 5MM VERTICAL BACK.DA52:0 .....	23
FILE NAME: DIGI-194Q 2440 MHZ BLE BODY D 5MM VERTICAL BACK.DA52:0 .....	24
FILE NAME: DIGI-194Q 2480 MHZ BLE BODY D 5MM VERTICAL BACK.DA52:0 .....	25
FILE NAME: DIGI-194Q 2402 MHZ BLE BODY D 5MM HORIZONTAL UP.DA52:0 .....	26
FILE NAME: DIGI-194Q 2440 MHZ BLE BODY D 5MM HORIZONTAL UP.DA52:0 .....	27
FILE NAME: DIGI-194Q 2480 MHZ BLE BODY D 5MM HORIZONTAL UP.DA52:0 .....	28
FILE NAME: DIGI-194Q 2402 MHZ BLE BODY D 5MM HORIZONTAL DOWN.DA52:0 .....	29
FILE NAME: DIGI-194Q 2440 MHZ BLE BODY D 5MM HORIZONTAL DOWN.DA52:0 .....	30
FILE NAME: DIGI-194Q 2480 MHZ BLE BODY D 5MM HORIZONTAL DOWN.DA52:0 .....	31
FILE NAME: DIGI-194Q 2402 MHZ BLE BODY D 5MM TIP MODE.DA52:0 .....	32
FILE NAME: DIGI-194Q 2440 MHZ BLE BODY D 5MM TIP MODE.DA52:0 .....	33
FILE NAME: DIGI-194Q 2480 MHZ BLE BODY D 5MM TIP MODE.DA52:0 .....	34
<b>EXHIBIT 4. BLE (2 MBPS) BODY MEASUREMENTS .....</b>	<b>35</b>
FILE NAME: DIGI-194Q 2404 MHZ BLE (2MBPS) BODY D 5MM VERTICAL FRONT.DA52:0 .....	35
FILE NAME: DIGI-194Q 2440 MHZ BLE (2MBPS) BODY D 5MM VERTICAL FRONT.DA52:0 .....	36
FILE NAME: DIGI-194Q 2478 MHZ BLE (2MBPS) BODY D 5MM VERTICAL FRONT.DA52:0 .....	37
FILE NAME: DIGI-194Q 2404 MHZ BLE (2MBPS) BODY D 5MM VERTICAL BACK.DA52:0 .....	38
FILE NAME: DIGI-194Q 2440 MHZ BLE (2MBPS) BODY D 5MM VERTICAL BACK.DA52:0 .....	39
FILE NAME: DIGI-194Q 2478 MHZ BLE (2MBPS) BODY D 5MM VERTICAL BACK.DA52:0 .....	40
FILE NAME: DIGI-194Q 2404 MHZ BLE (2MBPS) BODY D 5MM HORIZONTAL UP.DA52:0 .....	41
FILE NAME: DIGI-194Q 2440 MHZ BLE (2MBPS) BODY D 5MM HORIZONTAL UP.DA52:0 .....	42
FILE NAME: DIGI-194Q 2478 MHZ BLE (2MBPS) BODY D 5MM HORIZONTAL UP.DA52:0 .....	43
FILE NAME: DIGI-194Q 2404 MHZ BLE (2MBPS) BODY D 5MM HORIZONTAL DOWN.DA52:0 .....	44
FILE NAME: DIGI-194Q 2440 MHZ BLE (2MBPS) BODY D 5MM HORIZONTAL DOWN.DA52:0 .....	45
FILE NAME: DIGI-194Q 2478 MHZ BLE (2MBPS) BODY D 5MM HORIZONTAL DOWN.DA52:0 .....	46
FILE NAME: DIGI-194Q 2404 MHZ BLE (2MBPS) BODY D 5MM TIP MODE.DA52:0 .....	47
FILE NAME: DIGI-194Q 2440 MHZ BLE (2MBPS) BODY D 5MM TIP MODE.DA52:0 .....	48
FILE NAME: DIGI-194Q 2478 MHZ BLE (2MBPS) BODY D 5MM TIP MODE.DA52:0 .....	49

## EXHIBIT 1. SAR MEASUREMENTS RESULTS

ZigBee	Power (dBm)	CH. Freq (MHz)	Body SAR1g (W/Kg)	Body SAR10g (W/Kg)	Power Drift (dB)
Vertical Front	19.11	2405	0.783	0.395	-0.86
	19.25	2440	0.825	0.411	-0.23
	19.40	2480	0.680	0.345	-0.34
Vertical Back	19.11	2405	0.622	0.286	-0.03
	19.25	2440	0.592	0.274	0.04
	19.40	2480	0.761	0.331	-0.07
Horizontal Up	19.11	2405	0.939	0.506	0.11
	19.25	2440	1.25	0.656	0.14
	19.40	2480	0.750	0.399	0.06
Horizontal Down	19.11	2405	0.825	0.443	0.21
	19.25	2440	0.937	0.500	0.09
	19.40	2480	0.987	0.478	0.28
Tip Mode	19.11	2405	0.060	0.032	0.27
	19.25	2440	0.056	0.031	-0.36
	19.40	2480	0.084	0.047	-0.24

BLE (1 Mbps)	Power (dBm)	CH. Freq (MHz)	Body SAR1g (W/Kg)	Body SAR10g (W/Kg)	Power Drift (dB)
Vertical Front	7.75	2402	0.085	0.047	-0.43
	7.69	2440	0.093	0.051	-0.50
	8.55	2480	0.107	0.058	0.60
Vertical Back	7.75	2402	0.067	0.038	0.31
	7.69	2440	0.065	0.037	-1.09
	8.55	2480	0.073	0.040	0.16
Horizontal Up	7.75	2402	0.084	0.050	0.08
	7.69	2440	0.076	0.046	0.28
	8.55	2480	0.117	0.066	0.07
Horizontal Down	7.75	2402	0.129	0.088	0.29
	7.69	2440	0.118	0.068	0.27
	8.55	2480	0.102	0.055	-0.16
Tip Mode	7.75	2402	0.00617	0.00435	0.79
	7.69	2440	0.00696	0.00486	-0.26
	8.55	2480	0.011	0.00685	-0.82

<b>BLE (2 Mbps)</b>	<b>Power (dBm)</b>	<b>CH. Freq (MHz)</b>	<b>Body SAR1g (W/Kg)</b>	<b>Body SAR10g (W/Kg)</b>	<b>Power Drift (dB)</b>
Vertical Front	7.70	2404	0.110	0.058	-0.59
	7.73	2440	0.149	0.077	-0.71
	7.27	2478	0.090	0.049	-0.35
Vertical Back	7.70	2404	0.130	0.063	0.42
	7.73	2440	0.111	0.054	-0.08
	7.27	2478	0.075	0.039	0.63
Horizontal Up	7.70	2404	0.100	0.054	0.20
	7.73	2440	0.140	0.073	1.07
	7.27	2478	0.114	0.059	-1.03
Horizontal Down	7.70	2404	0.150	0.074	0.21
	7.73	2440	0.197	0.094	-1.38
	7.27	2478	0.135	0.066	-0.25
Tip Mode	7.70	2404	0.010	0.00661	-0.33
	7.73	2440	0.013	0.008	1.57
	7.27	2478	0.011	0.0067	1.34

## EXHIBIT 2. ZIGBEE BODY MEASUREMENTS

**FILE NAME:** [DIGI-194Q 2405 MHZ ZIGBEE BODY D 5MM VERTICAL FRONT.DA52:0](#)

**DUT: DIGI XBPRR with Zigbee; Type: USB Dongle**

Communication System: UID 0, CW (0); Frequency: 2405 MHz; Duty Cycle: 1:1  
Medium parameters used (interpolated):  $f = 2405$  MHz;  $\sigma = 1.905$  S/m;  $\epsilon_r = 50.35$ ;  $\rho = 1000$  kg/m<sup>3</sup> ;  
Phantom section: Flat Section ; Measurement Standard: DASYS (IEEE/IEC/ANSI C63.19-2011)

DASY Configuration:

- Probe: EX3DV4 - SN3673; ConvF(7.48, 7.48, 7.48); Calibrated: 8/30/2022;
- Sensor-Surface: 1.4mm (Mechanical Surface Detection)
- Electronics: DAE4 Sn874; Calibrated: 8/25/2022
- Phantom: ELI 4.0; Type: QD OVA 001 BB; Serial: 1057
- DASYS 52.10.0(1446); SEMCAD X 14.6.10(7417)

**DIGI-194Q Body/Vertical Front d= 5mm/Area Scan (31x81x1):** Interpolated grid: dx=1.500 mm, dy=1.500 mm

Maximum value of SAR (interpolated) = 1.27 W/kg

**DIGI-194Q Body/Vertical Front d= 5mm/Zoom Scan (5x5x7) (5x5x7)/Cube 0:**

Measurement grid: dx=7.5mm, dy=7.5mm, dz=5mm

Reference Value = 2.994 V/m; Power Drift = -0.86 dB

Peak SAR (extrapolated) = 1.55 W/kg

**SAR(1 g) = 0.783 W/kg; SAR(10 g) = 0.395 W/kg** (SAR corrected for target medium)

Maximum value of SAR (measured) = 1.24 W/kg

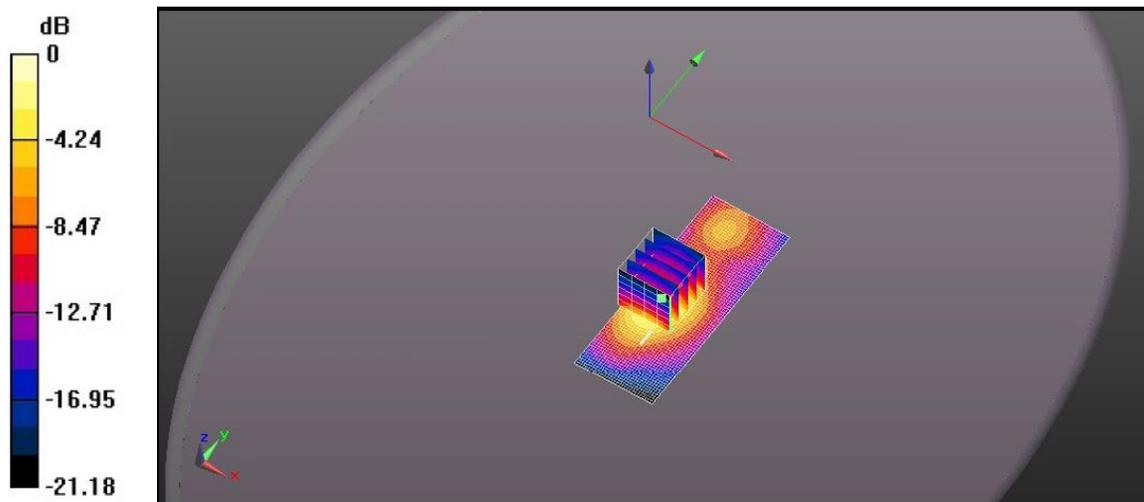

0 dB = 1.27 W/kg = 1.05 dBW/kg

**FILE NAME:** [DIGI-194Q 2440 MHZ ZIGBEE BODY D 5MM VERTICAL FRONT.DA52:0](#)

**DUT: DIGI XBPRR with Zigbee; Type: USB Dongle**

Communication System: UID 0, CW (0); Frequency: 2440 MHz; Duty Cycle: 1:1  
Medium parameters used (interpolated):  $f = 2440$  MHz;  $\sigma = 1.905$  S/m;  $\epsilon_r = 50.35$ ;  $\rho = 1000$  kg/m<sup>3</sup> ;  
Phantom section: Flat Section ; Measurement Standard: DASYS (IEEE/IEC/ANSI C63.19-2011)

DASY Configuration:

- Probe: EX3DV4 - SN3673; ConvF(7.48, 7.48, 7.48); Calibrated: 8/30/2022;
- Sensor-Surface: 1.4mm (Mechanical Surface Detection)
- Electronics: DAE4 Sn874; Calibrated: 8/25/2022
- Phantom: ELI 4.0; Type: QD OVA 001 BB; Serial: 1057
- DASYS2 52.10.0(1446); SEMCAD X 14.6.10(7417)

**DIGI-194Q Body/Vertical Front d= 5mm/Area Scan (31x81x1):** Interpolated grid: dx=1.500 mm, dy=1.500 mm

Maximum value of SAR (interpolated) = 1.32 W/kg

**DIGI-194Q Body/Vertical Front d= 5mm/Zoom Scan (5x5x7) (5x5x7)/Cube 0:**

Measurement grid: dx=7.5mm, dy=7.5mm, dz=5mm

Reference Value = 3.441 V/m; Power Drift = -0.23 dB

Peak SAR (extrapolated) = 1.64 W/kg

**SAR(1 g) = 0.825 W/kg; SAR(10 g) = 0.411 W/kg** (SAR corrected for target medium)

Maximum value of SAR (measured) = 1.32 W/kg

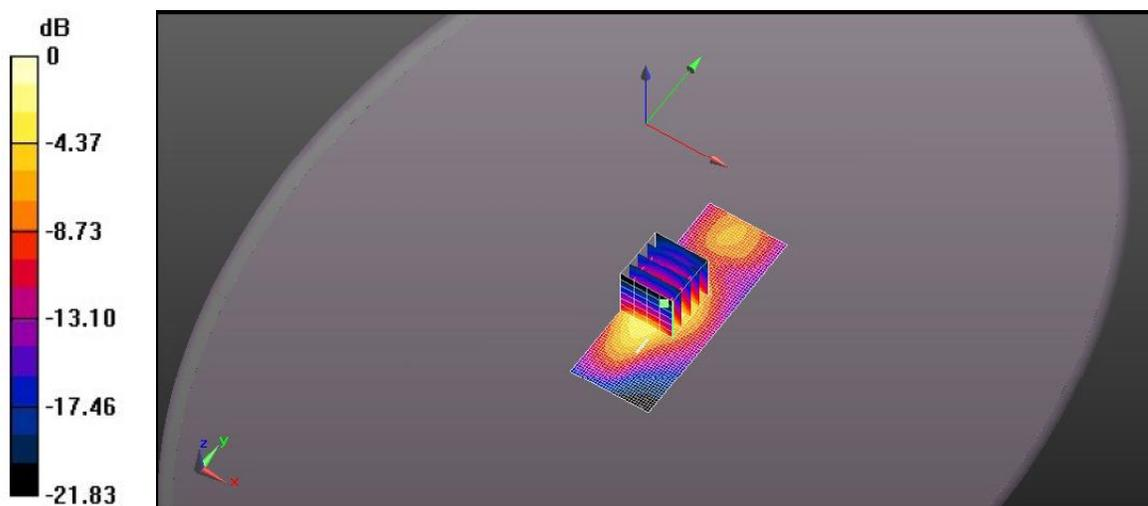

0 dB = 1.32 W/kg = 1.20 dBW/kg

**FILE NAME:** [DIGI-194Q 2480 MHZ ZIGBEE BODY D 5MM VERTICAL FRONT.DA52:0](#)

**DUT: DIGI XBPRR with Zigbee; Type: USB Dongle**

Communication System: UID 0, CW (0); Frequency: 2480 MHz; Duty Cycle: 1:1  
Medium parameters used (interpolated):  $f = 2480$  MHz;  $\sigma = 1.999$  S/m;  $\epsilon_r = 50.059$ ;  $\rho = 1000$  kg/m<sup>3</sup> ;  
Phantom section: Flat Section ; Measurement Standard: DASYS (IEEE/IEC/ANSI C63.19-2011)

DASY Configuration:

- Probe: EX3DV4 - SN3673; ConvF(7.48, 7.48, 7.48); Calibrated: 8/30/2022;
- Sensor-Surface: 1.4mm (Mechanical Surface Detection)
- Electronics: DAE4 Sn874; Calibrated: 8/25/2022
- Phantom: ELI 4.0; Type: QD OVA 001 BB; Serial: 1057
- DASYS 52.10.0(1446); SEMCAD X 14.6.10(7417)

**DIGI-194Q Body/Vertical Front d= 5mm/Area Scan (41x81x1):** Interpolated grid: dx=1.500 mm, dy=1.500 mm

Maximum value of SAR (interpolated) = 1.08 W/kg

**DIGI-194Q Body/Vertical Front d= 5mm/Zoom Scan (5x5x7) (5x5x7)/Cube 0:**

Measurement grid: dx=7.5mm, dy=7.5mm, dz=5mm

Reference Value = 5.514 V/m; Power Drift = -0.34 dB

Peak SAR (extrapolated) = 1.35 W/kg

**SAR(1 g) = 0.680 W/kg; SAR(10 g) = 0.345 W/kg** (SAR corrected for target medium)

Maximum value of SAR (measured) = 1.07 W/kg

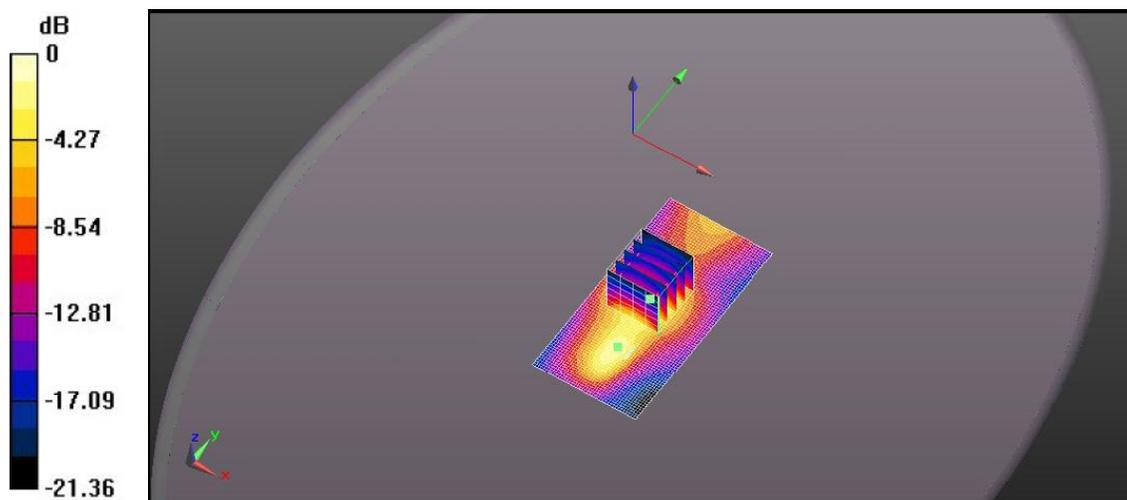

0 dB = 1.08 W/kg = 0.31 dBW/kg

**FILE NAME:** [DIGI-194Q 2405 MHZ ZIGBEE BODY D 5MM VERTICAL BACK.DA52:0](#)

**DUT: DIGI XBPRR with Zigbee; Type: USB Dongle**

Communication System: UID 0, CW (0); Frequency: 2405 MHz; Duty Cycle: 1:1  
Medium parameters used (interpolated):  $f = 2405$  MHz;  $\sigma = 1.901$  S/m;  $\epsilon_r = 50.355$ ;  $\rho = 1000$  kg/m<sup>3</sup> ;  
Phantom section: Flat Section ; Measurement Standard: DASYS (IEEE/IEC/ANSI C63.19-2011)

DASY Configuration:

- Probe: EX3DV4 - SN3673; ConvF(7.48, 7.48, 7.48); Calibrated: 8/30/2022;
- Sensor-Surface: 1.4mm (Mechanical Surface Detection)
- Electronics: DAE4 Sn874; Calibrated: 8/25/2022
- Phantom: ELI 4.0; Type: QD OVA 001 BB; Serial: 1057
- DASYS 52.10.0(1446); SEMCAD X 14.6.10(7417)

**DIGI-194Q Body/Vertical Back d= 5mm/Area Scan (41x81x1):** Interpolated grid: dx=1.500 mm, dy=1.500 mm

Maximum value of SAR (interpolated) = 0.998 W/kg

**DIGI-194Q Body/Vertical Back d= 5mm/Zoom Scan (5x5x7) (5x5x7)/Cube 0:**

Measurement grid: dx=7.5mm, dy=7.5mm, dz=5mm

Reference Value = 5.468 V/m; Power Drift = -0.03 dB

Peak SAR (extrapolated) = 1.42 W/kg

**SAR(1 g) = 0.622 W/kg; SAR(10 g) = 0.286 W/kg** (SAR corrected for target medium)

Maximum value of SAR (measured) = 1.05 W/kg

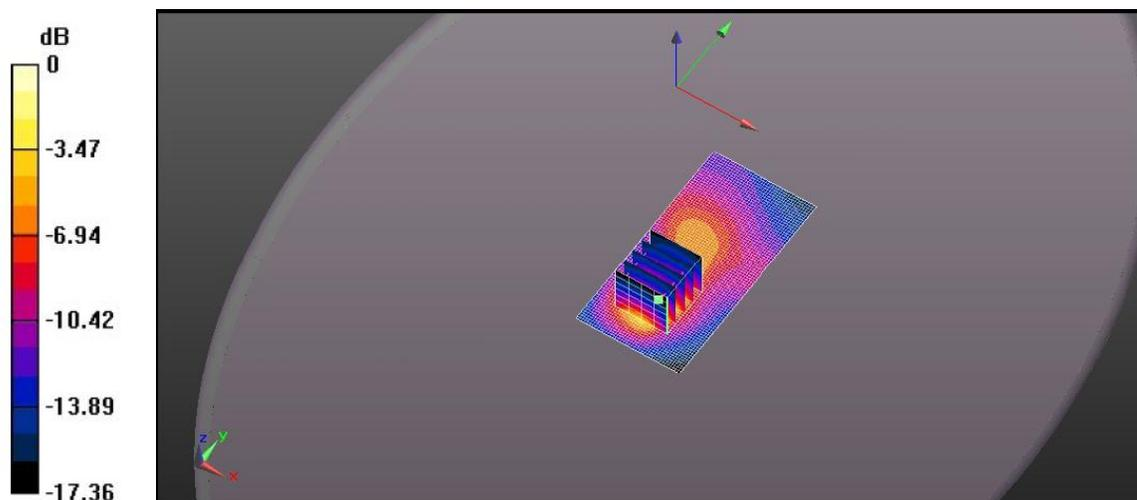

0 dB = 0.998 W/kg = -0.01 dBW/kg



**FILE NAME:** [DIGI-194Q 2440 MHZ ZIGBEE BODY D 5MM VERTICAL BACK.DA52:0](#)

**DUT: DIGI XBPRR with Zigbee; Type: USB Dongle**

Communication System: UID 0, CW (0); Frequency: 2440 MHz; Duty Cycle: 1:1  
Medium parameters used (interpolated):  $f = 2440$  MHz;  $\sigma = 1.95$  S/m;  $\epsilon_r = 50.204$ ;  $\rho = 1000$  kg/m<sup>3</sup> ;  
Phantom section: Flat Section ; Measurement Standard: DASYS (IEEE/IEC/ANSI C63.19-2011)

DASY Configuration:

- Probe: EX3DV4 - SN3673; ConvF(7.48, 7.48, 7.48); Calibrated: 8/30/2022;
- Sensor-Surface: 1.4mm (Mechanical Surface Detection)
- Electronics: DAE4 Sn874; Calibrated: 8/25/2022
- Phantom: ELI 4.0; Type: QD OVA 001 BB; Serial: 1057
- DASYS 52.10.0(1446); SEMCAD X 14.6.10(7417)

**DIGI-194Q Body/Vertical Back d= 5mm/Area Scan (31x81x1):** Interpolated grid: dx=1.500 mm, dy=1.500 mm

Maximum value of SAR (interpolated) = 0.941 W/kg

**DIGI-194Q Body/Vertical Back d= 5mm/Zoom Scan (5x5x7) (5x5x7)/Cube 0:**

Measurement grid: dx=7.5mm, dy=7.5mm, dz=5mm

Reference Value = 5.662 V/m; Power Drift = 0.04 dB

Peak SAR (extrapolated) = 1.35 W/kg

**SAR(1 g) = 0.592 W/kg; SAR(10 g) = 0.274 W/kg** (SAR corrected for target medium)

Maximum value of SAR (measured) = 1.03 W/kg

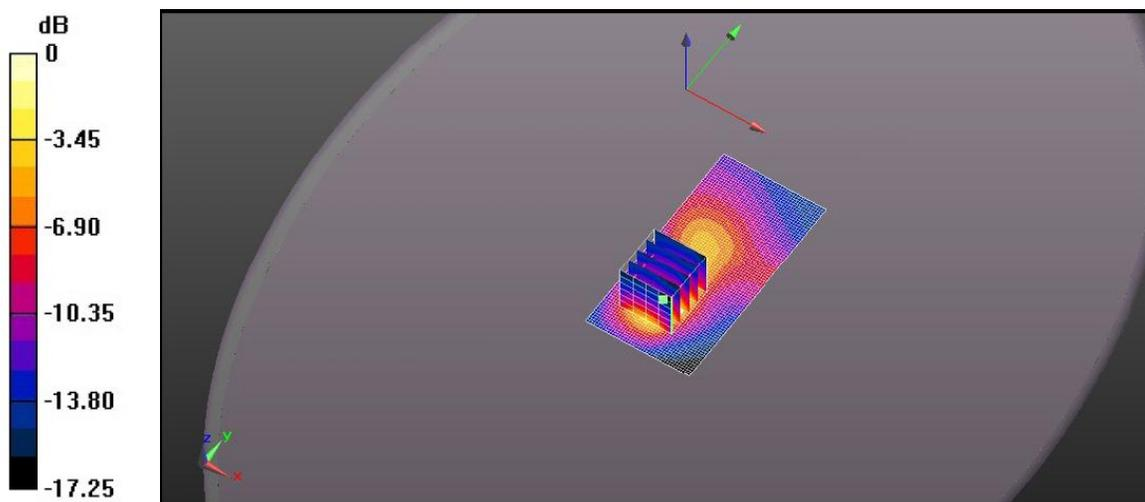

0 dB = 0.941 W/kg = -0.26 dBW/kg

**FILE NAME:** [DIGI-194Q 2480 MHZ ZIGBEE BODY D 5MM VERTICAL BACK.DA52:0](#)

**DUT: DIGI XBPRR with Zigbee; Type: USB Dongle**

Communication System: UID 0, CW (0); Frequency: 2480 MHz; Duty Cycle: 1:1  
Medium parameters used (interpolated):  $f = 2480$  MHz;  $\sigma = 1.999$  S/m;  $\epsilon_r = 50.059$ ;  $\rho = 1000$  kg/m<sup>3</sup> ;  
Phantom section: Flat Section ; Measurement Standard: DASYS (IEEE/IEC/ANSI C63.19-2011)

DASY Configuration:

- Probe: EX3DV4 - SN3673; ConvF(7.48, 7.48, 7.48); Calibrated: 8/30/2022;
- Sensor-Surface: 1.4mm (Mechanical Surface Detection)
- Electronics: DAE4 Sn874; Calibrated: 8/25/2022
- Phantom: ELI 4.0; Type: QD OVA 001 BB; Serial: 1057
- DASYS2 52.10.0(1446); SEMCAD X 14.6.10(7417)

**DIGI-194Q Body/Vertical Back d= 5mm/Area Scan (41x81x1):** Interpolated grid: dx=1.500 mm, dy=1.500 mm

Maximum value of SAR (interpolated) = 1.19 W/kg

**DIGI-194Q Body/Vertical Back d= 5mm/Zoom Scan (5x5x7) (5x5x7)/Cube 0:**

Measurement grid: dx=7.5mm, dy=7.5mm, dz=5mm

Reference Value = 6.082 V/m; Power Drift = -0.07 dB

Peak SAR (extrapolated) = 1.80 W/kg

**SAR(1 g) = 0.761 W/kg; SAR(10 g) = 0.331 W/kg** (SAR corrected for target medium)

Maximum value of SAR (measured) = 1.33 W/kg

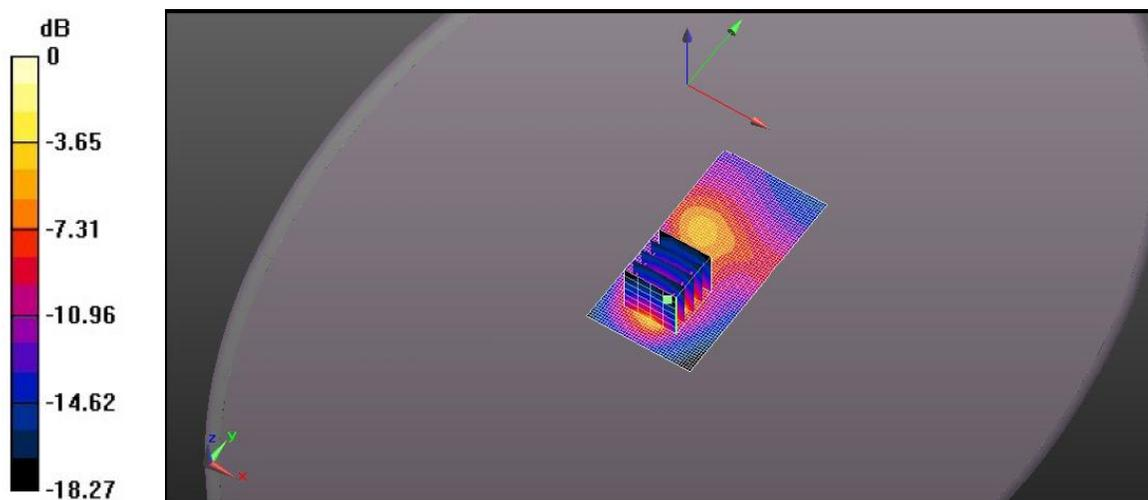

0 dB = 1.19 W/kg = 0.77 dBW/kg

**FILE NAME:** [DIGI-194Q 2405 MHZ ZIGBEE BODY D 5MM HORIZONTAL UP.DA52:0](#)

**DUT: DIGI XBPRR with Zigbee; Type: USB Dongle**

Communication System: UID 0, CW (0); Frequency: 2405 MHz; Duty Cycle: 1:1  
Medium parameters used (interpolated):  $f = 2405$  MHz;  $\sigma = 1.905$  S/m;  $\epsilon_r = 50.35$ ;  $\rho = 1000$  kg/m<sup>3</sup> ;  
Phantom section: Flat Section ; Measurement Standard: DASYS (IEEE/IEC/ANSI C63.19-2011)

DASY Configuration:

- Probe: EX3DV4 - SN3673; ConvF(7.48, 7.48, 7.48); Calibrated: 8/30/2022;
- Sensor-Surface: 1.4mm (Mechanical Surface Detection)
- Electronics: DAE4 Sn874; Calibrated: 8/25/2022
- Phantom: ELI 4.0; Type: QD OVA 001 BB; Serial: 1057
- DASYS 52.10.0(1446); SEMCAD X 14.6.10(7417)

**DIGI-194Q Body/Horizontal Up d= 5mm/Area Scan (31x81x1):** Interpolated grid: dx=1.500 mm, dy=1.500 mm

Maximum value of SAR (interpolated) = 1.49 W/kg

**DIGI-194Q Body/Horizontal Up d= 5mm/Zoom Scan (5x5x7) (5x5x7)/Cube 0:**

Measurement grid: dx=7.5mm, dy=7.5mm, dz=5mm

Reference Value = 20.26 V/m; Power Drift = 0.11 dB

Peak SAR (extrapolated) = 1.78 W/kg

**SAR(1 g) = 0.939 W/kg; SAR(10 g) = 0.506 W/kg** (SAR corrected for target medium)

Maximum value of SAR (measured) = 1.45 W/kg

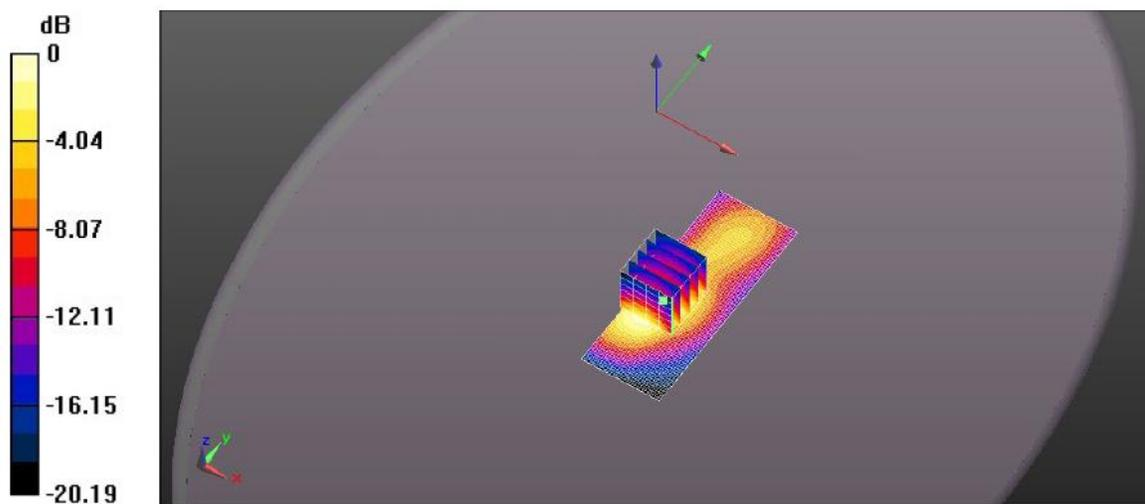

0 dB = 1.49 W/kg = 1.75 dBW/kg

**FILE NAME:** [DIGI-194Q 2440 MHZ ZIGBEE BODY D 5MM HORIZONTAL UP.DA52:0](#)

**DUT: DIGI XBPRR with Zigbee; Type: USB Dongle**

Communication System: UID 0, CW (0); Frequency: 2440 MHz; Duty Cycle: 1:1  
Medium parameters used (interpolated):  $f = 2440$  MHz;  $\sigma = 1.95$  S/m;  $\epsilon_r = 50.204$ ;  $\rho = 1000$  kg/m<sup>3</sup> ;  
Phantom section: Flat Section ; Measurement Standard: DASYS (IEEE/IEC/ANSI C63.19-2011)

DASY Configuration:

- Probe: EX3DV4 - SN3673; ConvF(7.48, 7.48, 7.48); Calibrated: 8/30/2022;
- Sensor-Surface: 1.4mm (Mechanical Surface Detection)
- Electronics: DAE4 Sn874; Calibrated: 8/25/2022
- Phantom: ELI 4.0; Type: QD OVA 001 BB; Serial: 1057
- DASYS 52.10.0(1446); SEMCAD X 14.6.10(7417)

**DIGI-194Q Body/Horizontal Up d= 5mm/Area Scan (31x81x1):** Interpolated grid: dx=1.500 mm, dy=1.500 mm

Maximum value of SAR (interpolated) = 1.92 W/kg

**DIGI-194Q Body/Horizontal Up d= 5mm/Zoom Scan (5x5x7) (5x5x7)/Cube 0:**

Measurement grid: dx=7.5mm, dy=7.5mm, dz=5mm

Reference Value = 27.78 V/m; Power Drift = 0.14 dB

Peak SAR (extrapolated) = 2.38 W/kg

**SAR(1 g) = 1.25 W/kg; SAR(10 g) = 0.656 W/kg** (SAR corrected for target medium)

Maximum value of SAR (measured) = 1.93 W/kg

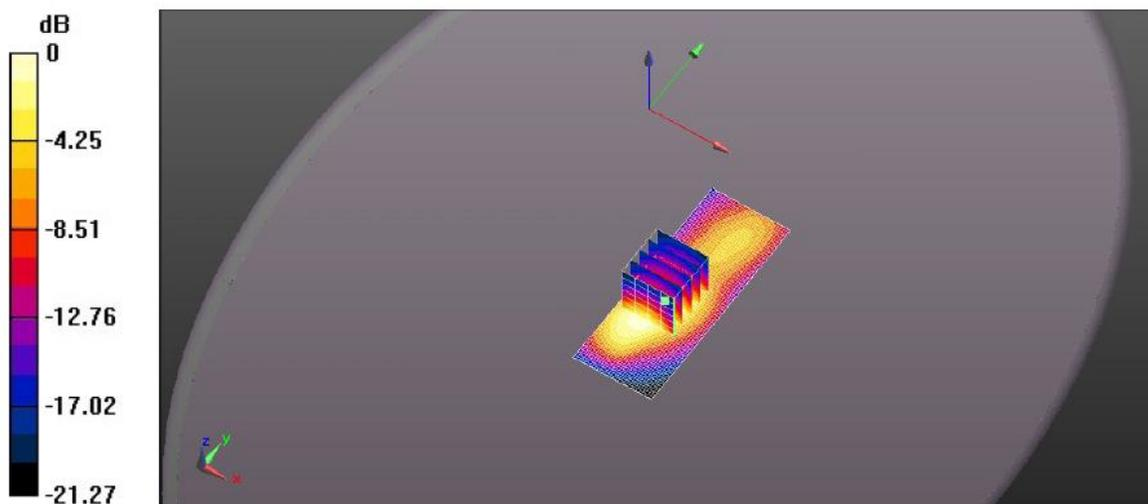

0 dB = 1.92 W/kg = 2.83 dBW/kg

**FILE NAME:** [DIGI-194Q 2480 MHZ ZIGBEE BODY D 5MM HORIZONTAL UP.DA52:0](#)

**DUT: DIGI XBPRR with Zigbee; Type: USB Dongle**

Communication System: UID 0, CW (0); Frequency: 2480 MHz; Duty Cycle: 1:1  
Medium parameters used (interpolated):  $f = 2480$  MHz;  $\sigma = 1.999$  S/m;  $\epsilon_r = 50.059$ ;  $\rho = 1000$  kg/m<sup>3</sup> ;  
Phantom section: Flat Section ; Measurement Standard: DASYS (IEEE/IEC/ANSI C63.19-2011)

DASY Configuration:

- Probe: EX3DV4 - SN3673; ConvF(7.48, 7.48, 7.48); Calibrated: 8/30/2022;
- Sensor-Surface: 1.4mm (Mechanical Surface Detection)
- Electronics: DAE4 Sn874; Calibrated: 8/25/2022
- Phantom: ELI 4.0; Type: QD OVA 001 BB; Serial: 1057
- DASYS2 52.10.0(1446); SEMCAD X 14.6.10(7417)

**DIGI-194Q Body/Horizontal Up d= 5mm/Area Scan (31x81x1):** Interpolated grid: dx=1.500 mm, dy=1.500 mm

Maximum value of SAR (interpolated) = 1.19 W/kg

**DIGI-194Q Body/Horizontal Up d= 5mm/Zoom Scan (5x5x7) (5x5x7)/Cube 0:**

Measurement grid: dx=7.5mm, dy=7.5mm, dz=5mm

Reference Value = 15.68 V/m; Power Drift = 0.06 dB

Peak SAR (extrapolated) = 1.43 W/kg

**SAR(1 g) = 0.750 W/kg; SAR(10 g) = 0.399 W/kg** (SAR corrected for target medium)

Maximum value of SAR (measured) = 1.16 W/kg

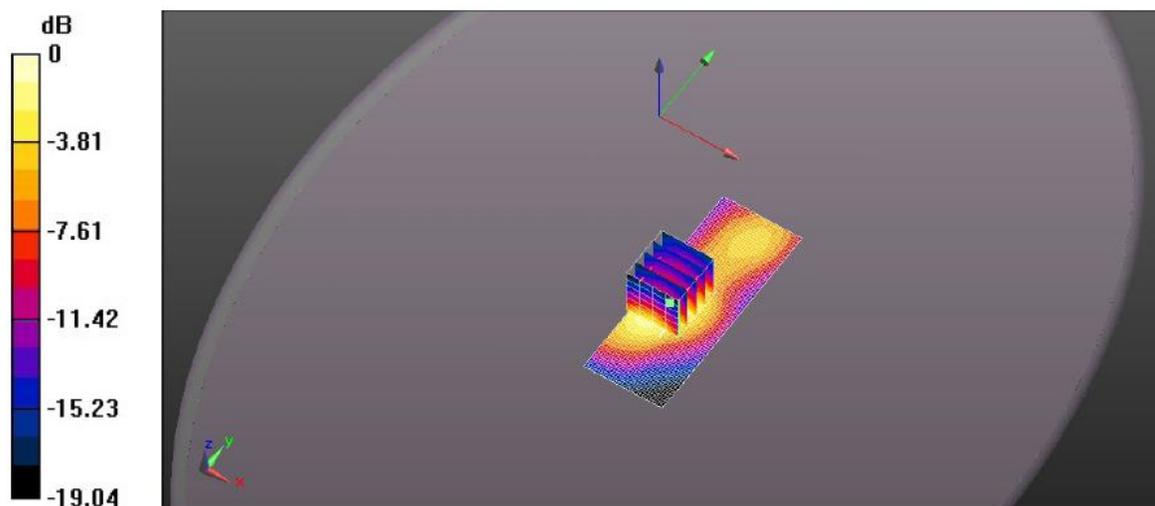

0 dB = 1.19 W/kg = 0.74 dBW/kg

**FILE NAME:** [DIGI-194Q 2405 MHZ ZIGBEE BODY D 5MM HORIZONTAL DOWN.DA52:0](#)

**DUT: DIGI XBPRR with Zigbee; Type: USB Dongle**

Communication System: UID 0, CW (0); Frequency: 2405 MHz; Duty Cycle: 1:1  
Medium parameters used (interpolated):  $f = 2405$  MHz;  $\sigma = 1.905$  S/m;  $\epsilon_r = 50.35$ ;  $\rho = 1000$  kg/m<sup>3</sup> ;  
Phantom section: Flat Section ; Measurement Standard: DASYS (IEEE/IEC/ANSI C63.19-2011)

DASY Configuration:

- Probe: EX3DV4 - SN3673; ConvF(7.48, 7.48, 7.48); Calibrated: 8/30/2022;
- Sensor-Surface: 1.4mm (Mechanical Surface Detection)
- Electronics: DAE4 Sn874; Calibrated: 8/25/2022
- Phantom: ELI 4.0; Type: QD OVA 001 BB; Serial: 1057
- DASYS2 52.10.0(1446); SEMCAD X 14.6.10(7417)

**DIGI-194Q Body/Horizontal Down d= 5mm/Area Scan (31x81x1):** Interpolated grid:  
dx=1.500 mm, dy=1.500 mm  
Maximum value of SAR (interpolated) = 1.29 W/kg

**DIGI-194Q Body/Horizontal Down d= 5mm/Zoom Scan (5x5x7) (5x5x7)/Cube 0:**  
Measurement grid: dx=7.5mm, dy=7.5mm, dz=5mm  
Reference Value = 19.33 V/m; Power Drift = 0.21 dB  
Peak SAR (extrapolated) = 1.58 W/kg  
**SAR(1 g) = 0.825 W/kg; SAR(10 g) = 0.443 W/kg** (SAR corrected for target medium)  
Maximum value of SAR (measured) = 1.28 W/kg

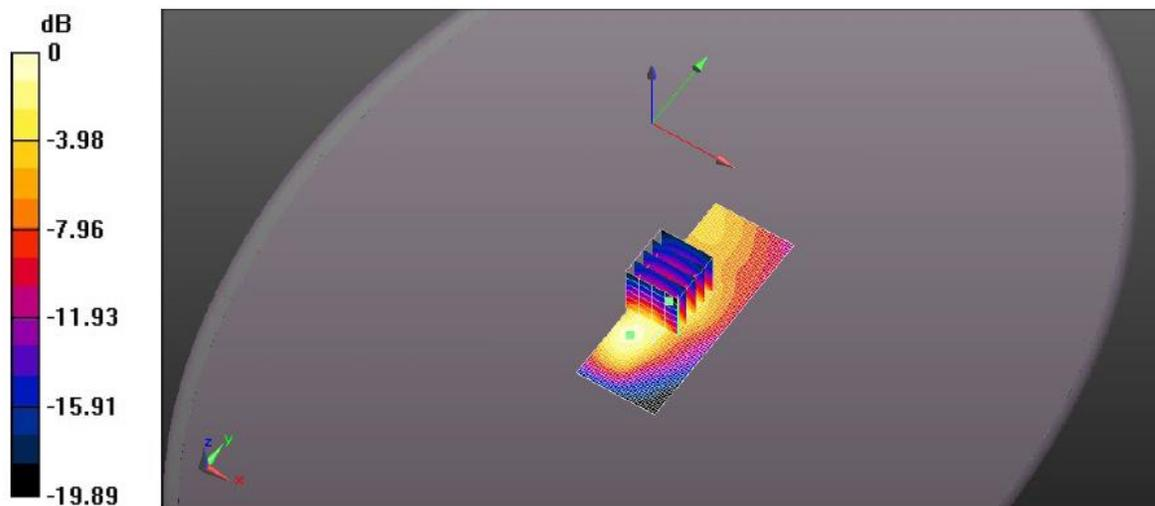

0 dB = 1.29 W/kg = 1.10 dBW/kg

**FILE NAME:** [DIGI-194Q 2440 MHZ ZIGBEE BODY D 5MM HORIZONTAL DOWN.DA52:0](#)

**DUT: DIGI XBPRR with Zigbee; Type: USB Dongle**

Communication System: UID 0, CW (0); Frequency: 2440 MHz; Duty Cycle: 1:1  
Medium parameters used (interpolated):  $f = 2440$  MHz;  $\sigma = 1.95$  S/m;  $\epsilon_r = 50.204$ ;  $\rho = 1000$  kg/m<sup>3</sup> ;  
Phantom section: Flat Section ; Measurement Standard: DASYS (IEEE/IEC/ANSI C63.19-2011)

DASY Configuration:

- Probe: EX3DV4 - SN3673; ConvF(7.48, 7.48, 7.48); Calibrated: 8/30/2022;
- Sensor-Surface: 1.4mm (Mechanical Surface Detection)
- Electronics: DAE4 Sn874; Calibrated: 8/25/2022
- Phantom: ELI 4.0; Type: QD OVA 001 BB; Serial: 1057
- DASYS 52.10.0(1446); SEMCAD X 14.6.10(7417)

**DIGI-194Q Body/Horizontal Down d= 5mm/Area Scan (31x81x1):** Interpolated grid:  
dx=1.500 mm, dy=1.500 mm  
Maximum value of SAR (interpolated) = 1.47 W/kg

**DIGI-194Q Body/Horizontal Down d= 5mm/Zoom Scan (5x5x7) (5x5x7)/Cube 0:**  
Measurement grid: dx=7.5mm, dy=7.5mm, dz=5mm  
Reference Value = 22.44 V/m; Power Drift = 0.09 dB  
Peak SAR (extrapolated) = 1.81 W/kg  
**SAR(1 g) = 0.937 W/kg; SAR(10 g) = 0.500 W/kg** (SAR corrected for target medium)  
Maximum value of SAR (measured) = 1.46 W/kg

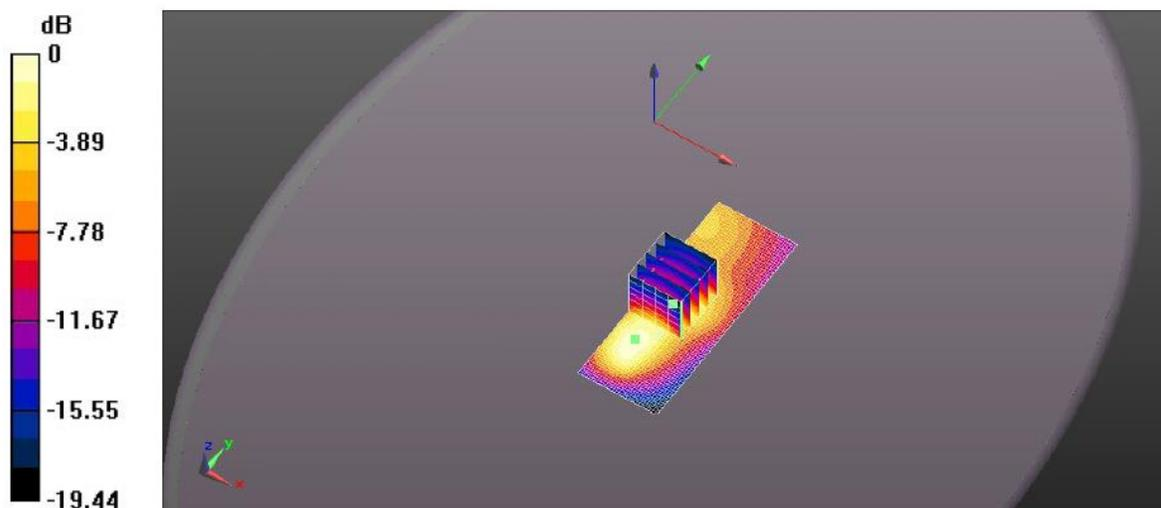

0 dB = 1.47 W/kg = 1.66 dBW/kg

**FILE NAME:** [DIGI-194Q 2480 MHZ ZIGBEE BODY D 5MM HORIZONTAL DOWN.DA52:0](#)

**DUT: DIGI XBPRR with Zigbee; Type: USB Dongle**

Communication System: UID 0, CW (0); Frequency: 2480 MHz; Duty Cycle: 1:1  
Medium parameters used (interpolated):  $f = 2480$  MHz;  $\sigma = 1.999$  S/m;  $\epsilon_r = 50.059$ ;  $\rho = 1000$  kg/m<sup>3</sup> ;  
Phantom section: Flat Section ; Measurement Standard: DASYS (IEEE/IEC/ANSI C63.19-2011)

DASY Configuration:

- Probe: EX3DV4 - SN3673; ConvF(7.48, 7.48, 7.48); Calibrated: 8/30/2022;
- Sensor-Surface: 1.4mm (Mechanical Surface Detection)
- Electronics: DAE4 Sn874; Calibrated: 8/25/2022
- Phantom: ELI 4.0; Type: QD OVA 001 BB; Serial: 1057
- DASYS 52.10.0(1446); SEMCAD X 14.6.10(7417)

**DIGI-194Q Body/Horizontal Down d= 5mm/Area Scan (41x81x1):** Interpolated grid:  
dx=1.500 mm, dy=1.500 mm  
Maximum value of SAR (interpolated) = 1.76 W/kg

**DIGI-194Q Body/Horizontal Down d= 5mm/Zoom Scan (5x5x7) (5x5x7)/Cube 0:**  
Measurement grid: dx=7.5mm, dy=7.5mm, dz=5mm  
Reference Value = 21.10 V/m; Power Drift = 0.28 dB  
Peak SAR (extrapolated) = 2.13 W/kg  
**SAR(1 g) = 0.987 W/kg; SAR(10 g) = 0.478 W/kg** (SAR corrected for target medium)  
Maximum value of SAR (measured) = 1.64 W/kg

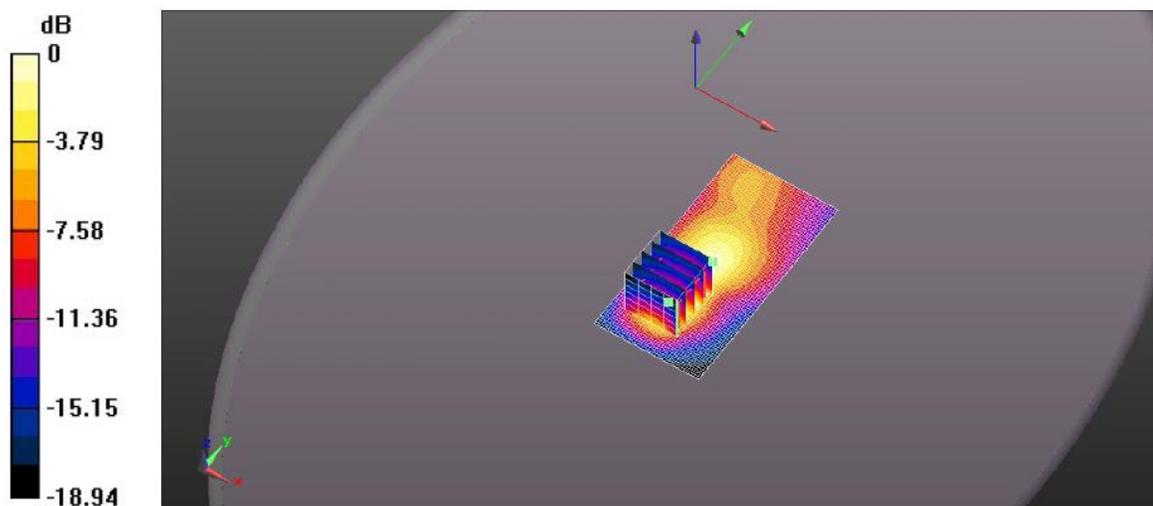

0 dB = 1.76 W/kg = 2.45 dBW/kg



**FILE NAME:** [DIGI-194Q 2405 MHZ ZIGBEE BODY D 5MM TIP MODE.DA52:0](#)

**DUT: DIGI XBPRR with Zigbee; Type: USB Dongle**

Communication System: UID 0, CW (0); Frequency: 2405 MHz; Duty Cycle: 1:1  
Medium parameters used (interpolated):  $f = 2405$  MHz;  $\sigma = 1.905$  S/m;  $\epsilon_r = 50.35$ ;  $\rho = 1000$  kg/m<sup>3</sup> ;  
Phantom section: Flat Section ; Measurement Standard: DASYS (IEEE/IEC/ANSI C63.19-2011)

DASY Configuration:

- Probe: EX3DV4 - SN3673; ConvF(7.48, 7.48, 7.48); Calibrated: 8/30/2022;
- Sensor-Surface: 1.4mm (Mechanical Surface Detection)
- Electronics: DAE4 Sn874; Calibrated: 8/25/2022
- Phantom: ELI 4.0; Type: QD OVA 001 BB; Serial: 1057
- DASYS 52.10.0(1446); SEMCAD X 14.6.10(7417)

**DIGI-194Q Body/Tip Mode d= 5mm/Area Scan (31x81x1):** Interpolated grid: dx=1.500 mm, dy=1.500 mm

Maximum value of SAR (interpolated) = 0.0806 W/kg

**DIGI-194Q Body/Tip Mode d= 5mm/Zoom Scan (5x5x7) (5x5x7)/Cube 0:** Measurement grid: dx=7.5mm, dy=7.5mm, dz=5mm

Reference Value = 3.002 V/m; Power Drift = 0.27 dB

Peak SAR (extrapolated) = 0.134 W/kg

**SAR(1 g) = 0.060 W/kg; SAR(10 g) = 0.032 W/kg** (SAR corrected for target medium)

Maximum value of SAR (measured) = 0.0958 W/kg

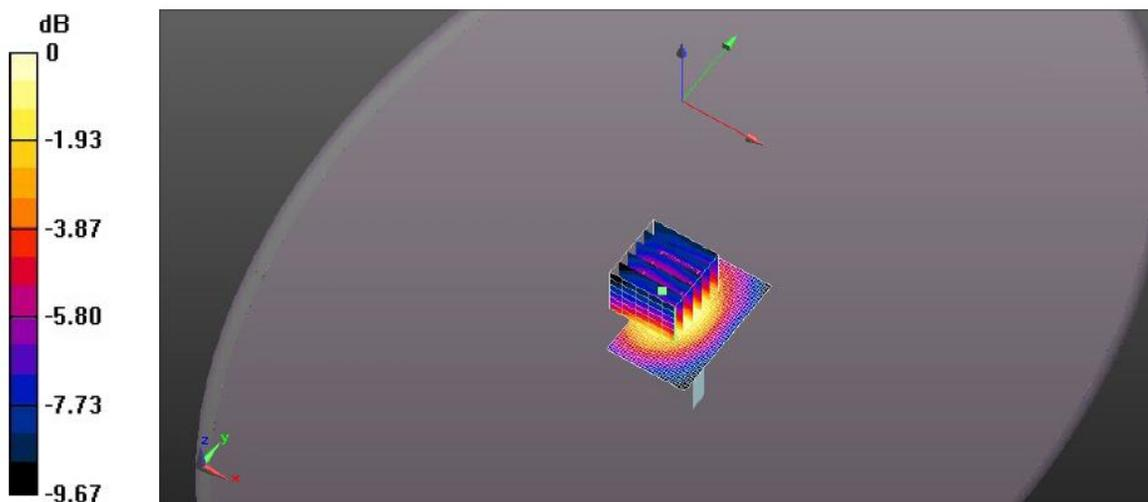

0 dB = 0.0806 W/kg = -10.93 dBW/kg

**FILE NAME:** [DIGI-194Q 2440 MHZ ZIGBEE BODY D 5MM TIP MODE.DA52:0](#)

**DUT: DIGI XBPRR with Zigbee; Type: USB Dongle**

Communication System: UID 0, CW (0); Frequency: 2440 MHz; Duty Cycle: 1:1  
Medium parameters used (interpolated):  $f = 2440$  MHz;  $\sigma = 1.95$  S/m;  $\epsilon_r = 50.204$ ;  $\rho = 1000$  kg/m<sup>3</sup> ;  
Phantom section: Flat Section ; Measurement Standard: DASYS (IEEE/IEC/ANSI C63.19-2011)

DASY Configuration:

- Probe: EX3DV4 - SN3673; ConvF(7.48, 7.48, 7.48); Calibrated: 8/30/2022;
- Sensor-Surface: 1.4mm (Mechanical Surface Detection)
- Electronics: DAE4 Sn874; Calibrated: 8/25/2022
- Phantom: ELI 4.0; Type: QD OVA 001 BB; Serial: 1057
- DASYS 52.10.0(1446); SEMCAD X 14.6.10(7417)

**DIGI-194Q Body/Tip Mode d= 5mm/Area Scan (41x81x1):** Interpolated grid: dx=1.500 mm, dy=1.500 mm

Maximum value of SAR (interpolated) = 0.101 W/kg

**DIGI-194Q Body/Tip Mode d= 5mm/Zoom Scan (5x5x7) (5x5x7)/Cube 0:** Measurement grid: dx=7.5mm, dy=7.5mm, dz=5mm

Reference Value = 2.623 V/m; Power Drift = -0.36 dB

Peak SAR (extrapolated) = 0.120 W/kg

**SAR(1 g) = 0.056 W/kg; SAR(10 g) = 0.031 W/kg** (SAR corrected for target medium)

Maximum value of SAR (measured) = 0.0924 W/kg

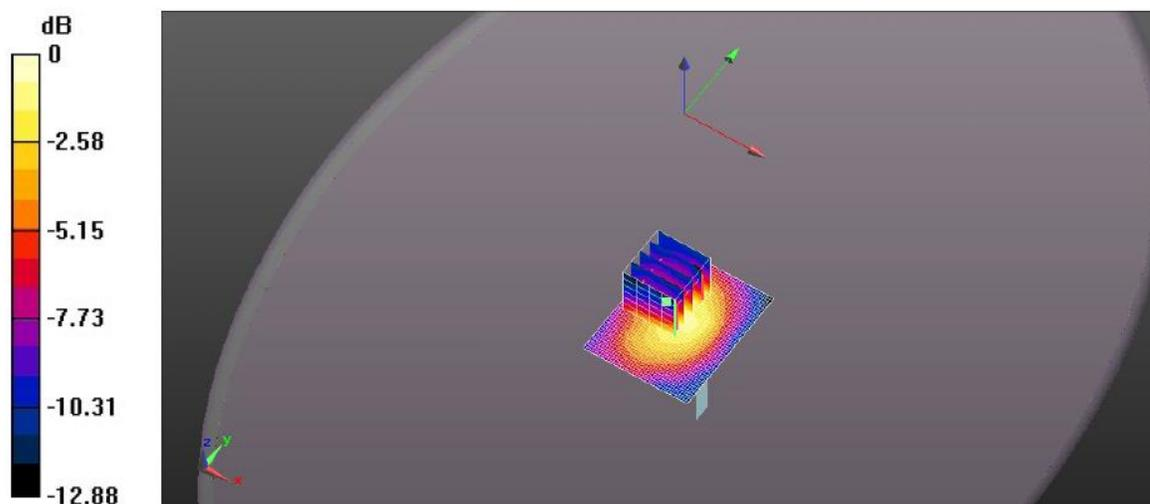

0 dB = 0.101 W/kg = -9.97 dBW/kg

**FILE NAME:** [DIGI-194Q 2480 MHZ ZIGBEE BODY D 5MM TIP MODE.DA52:0](#)

**DUT: DIGI XBPRR with Zigbee; Type: USB Dongle**

Communication System: UID 0, CW (0); Frequency: 2480 MHz; Duty Cycle: 1:1  
Medium parameters used (interpolated):  $f = 2480$  MHz;  $\sigma = 1.999$  S/m;  $\epsilon_r = 50.0594$ ;  $\rho = 1000$  kg/m<sup>3</sup> ;  
Phantom section: Flat Section ; Measurement Standard: DASYS (IEEE/IEC/ANSI C63.19-2011)

DASY Configuration:

- Probe: EX3DV4 - SN3673; ConvF(7.48, 7.48, 7.48); Calibrated: 8/30/2022;
- Sensor-Surface: 1.4mm (Mechanical Surface Detection)
- Electronics: DAE4 Sn874; Calibrated: 8/25/2022
- Phantom: ELI 4.0; Type: QD OVA 001 BB; Serial: 1057
- DASYS 52.10.0(1446); SEMCAD X 14.6.10(7417)

**DIGI-194Q Body/Tip Mode d= 5mm/Area Scan (41x51x1):** Interpolated grid: dx=1.500 mm, dy=1.500 mm

Maximum value of SAR (interpolated) = 0.141 W/kg

**DIGI-194Q Body/Tip Mode d= 5mm/Zoom Scan (5x5x7) (6x5x7)/Cube 0:** Measurement grid: dx=7.5mm, dy=7.5mm, dz=5mm

Reference Value = 3.564 V/m; Power Drift = -0.24 dB

Peak SAR (extrapolated) = 0.177 W/kg

**SAR(1 g) = 0.084 W/kg; SAR(10 g) = 0.047 W/kg** (SAR corrected for target medium)

Maximum value of SAR (measured) = 0.126 W/kg

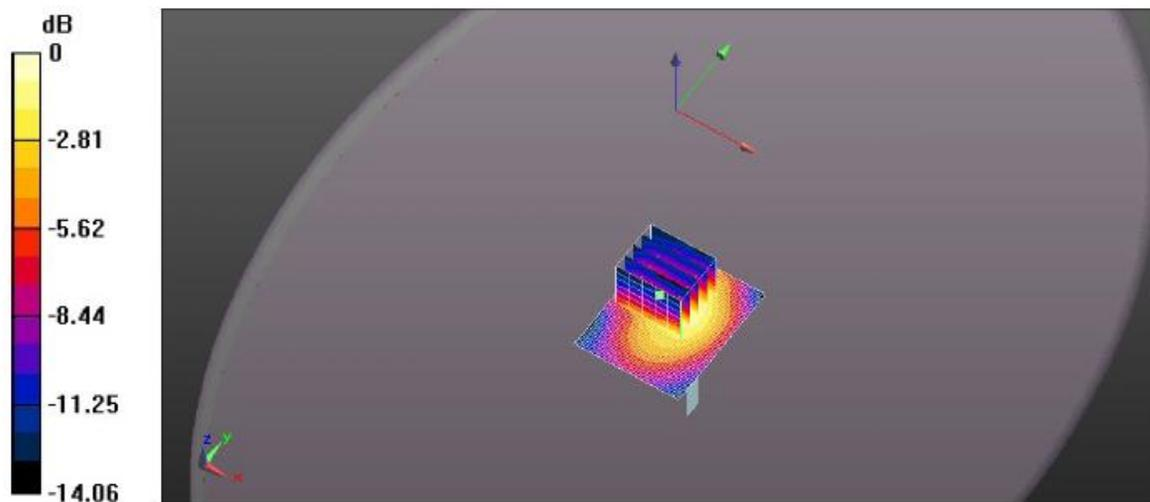

0 dB = 0.141 W/kg = -8.51 dBW/kg

### EXHIBIT 3. BLE (1 MBPS) BODY MEASUREMENTS

FILE NAME: [DIGI-194Q 2402 MHZ BLE BODY D 5MM VERTICAL FRONT.DA52:0](#)

DUT: DIGI XBPRR with BLE (1 Mbps); Type: USB Dongle

Communication System: UID 0, CW (0); Frequency: 2402 MHz; Duty Cycle: 1:1  
Medium parameters used (interpolated):  $f = 2402$  MHz;  $\sigma = 1.901$  S/m;  $\epsilon_r = 50.335$ ;  $\rho = 1000$  kg/m<sup>3</sup> ;  
Phantom section: Flat Section ; Measurement Standard: DASYS (IEEE/IEC/ANSI C63.19-2011)

DASY Configuration:

- Probe: EX3DV4 - SN3673; ConvF(7.48, 7.48, 7.48); Calibrated: 8/30/2022;
- Sensor-Surface: 1.4mm (Mechanical Surface Detection)
- Electronics: DAE4 Sn874; Calibrated: 8/25/2022
- Phantom: ELI 4.0; Type: QD OVA 001 BB; Serial: 1057
- DASYS 52.10.0(1446); SEMCAD X 14.6.10(7417)

**DIGI-194Q Body/Vertical Front d= 5mm/Area Scan (41x81x1):** Interpolated grid: dx=1.500 mm, dy=1.500 mm

Maximum value of SAR (interpolated) = 0.126 W/kg

**DIGI-194Q Body/Vertical Front d= 5mm/Zoom Scan (5x5x7) (5x5x7)/Cube 0:**

Measurement grid: dx=7.5mm, dy=7.5mm, dz=5mm

Reference Value = 2.723 V/m; Power Drift = -0.43 dB

Peak SAR (extrapolated) = 0.161 W/kg

**SAR(1 g) = 0.085 W/kg; SAR(10 g) = 0.047 W/kg** (SAR corrected for target medium)

Maximum value of SAR (measured) = 0.130 W/kg

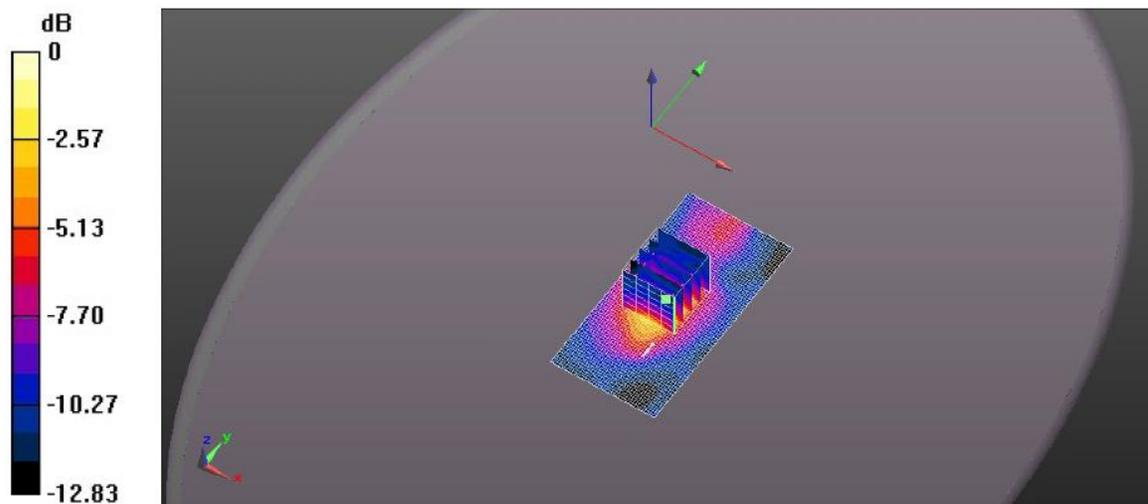

0 dB = 0.126 W/kg = -9.00 dBW/kg

**FILE NAME:** [DIGI-194Q 2440 MHZ BLE BODY D 5MM VERTICAL FRONT.DA52:0](#)

**DUT: DIGI XBPRR with BLE (1 Mbps); Type: USB Dongle**

Communication System: UID 0, CW (0); Frequency: 2440 MHz; Duty Cycle: 1:1  
Medium parameters used (interpolated):  $f = 2440$  MHz;  $\sigma = 1.95$  S/m;  $\epsilon_r = 50.204$ ;  $\rho = 1000$  kg/m<sup>3</sup> ;  
Phantom section: Flat Section ; Measurement Standard: DASYS (IEEE/IEC/ANSI C63.19-2011)

DASY Configuration:

- Probe: EX3DV4 - SN3673; ConvF(7.48, 7.48, 7.48); Calibrated: 8/30/2022;
- Sensor-Surface: 1.4mm (Mechanical Surface Detection)
- Electronics: DAE4 Sn874; Calibrated: 8/25/2022
- Phantom: ELI 4.0; Type: QD OVA 001 BB; Serial: 1057
- DASYS 52.10.0(1446); SEMCAD X 14.6.10(7417)

**DIGI-194Q Body/Vertical Front d= 5mm/Area Scan (41x81x1):** Interpolated grid: dx=1.500 mm, dy=1.500 mm

Maximum value of SAR (interpolated) = 0.137 W/kg

**DIGI-194Q Body/Vertical Front d= 5mm/Zoom Scan (5x5x7) (5x5x7)/Cube 0:**

Measurement grid: dx=7.5mm, dy=7.5mm, dz=5mm

Reference Value = 2.693 V/m; Power Drift = -0.50 dB

Peak SAR (extrapolated) = 0.177 W/kg

**SAR(1 g) = 0.093 W/kg; SAR(10 g) = 0.051 W/kg** (SAR corrected for target medium)

Maximum value of SAR (measured) = 0.143 W/kg

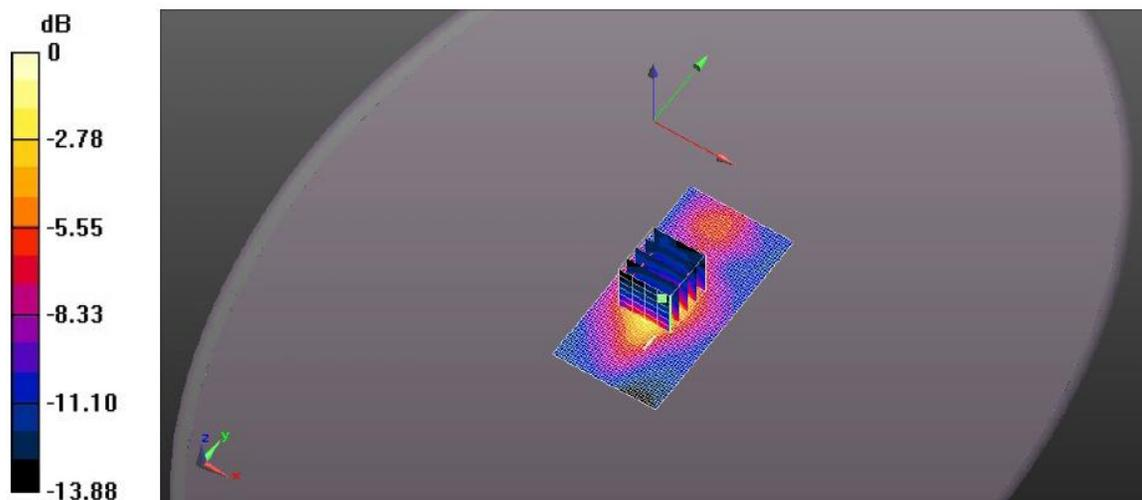

0 dB = 0.137 W/kg = -8.63 dBW/kg

**FILE NAME:** [DIGI-194Q 2480 MHZ BLE BODY D 5MM VERTICAL FRONT.DA52:0](#)

**DUT: DIGI XBPRR with BLE (1 Mbps); Type: USB Dongle**

Communication System: UID 0, CW (0); Frequency: 2480 MHz; Duty Cycle: 1:1  
Medium parameters used (interpolated):  $f = 2480$  MHz;  $\sigma = 1.999$  S/m;  $\epsilon_r = 50.059$ ;  $\rho = 1000$  kg/m<sup>3</sup> ;  
Phantom section: Flat Section ; Measurement Standard: DASYS (IEEE/IEC/ANSI C63.19-2011)

DASY Configuration:

- Probe: EX3DV4 - SN3673; ConvF(7.48, 7.48, 7.48); Calibrated: 8/30/2022;
- Sensor-Surface: 1.4mm (Mechanical Surface Detection)
- Electronics: DAE4 Sn874; Calibrated: 8/25/2022
- Phantom: ELI 4.0; Type: QD OVA 001 BB; Serial: 1057
- DASYS 52.10.0(1446); SEMCAD X 14.6.10(7417)

**DIGI-194Q Body/Vertical Front d= 5mm/Area Scan (41x81x1):** Interpolated grid: dx=1.500 mm, dy=1.500 mm

Maximum value of SAR (interpolated) = 0.163 W/kg

**DIGI-194Q Body/Vertical Front d= 5mm/Zoom Scan (5x5x7) (5x5x7)/Cube 0:**

Measurement grid: dx=7.5mm, dy=7.5mm, dz=5mm

Reference Value = 2.472 V/m; Power Drift = 0.60 dB

Peak SAR (extrapolated) = 0.210 W/kg

**SAR(1 g) = 0.107 W/kg; SAR(10 g) = 0.058 W/kg** (SAR corrected for target medium)

Maximum value of SAR (measured) = 0.168 W/kg

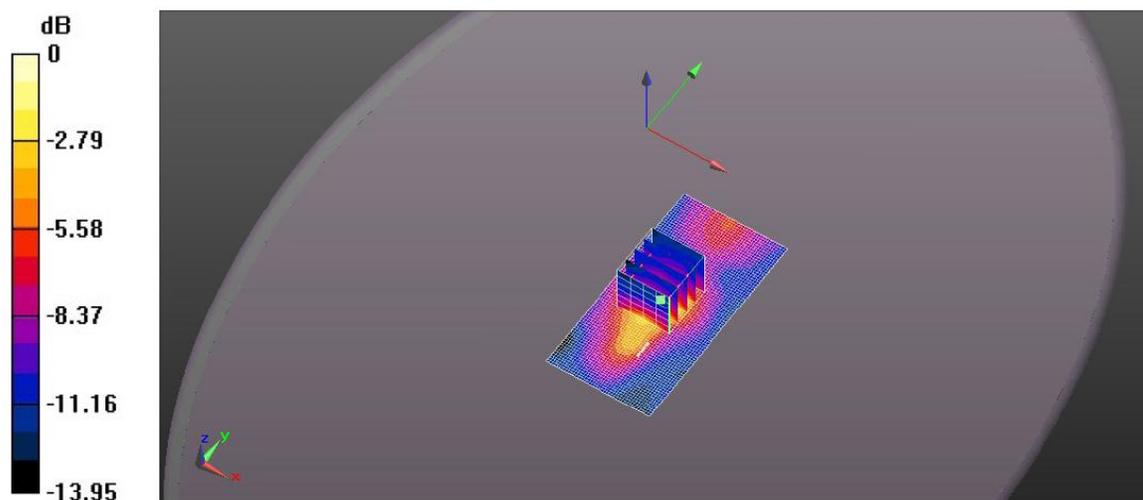

0 dB = 0.163 W/kg = -7.89 dBW/kg

**FILE NAME:** [DIGI-194Q 2402 MHZ BLE BODY D 5MM VERTICAL BACK.DA52:0](#)

**DUT: DIGI XBPRR with BLE (1 Mbps); Type: USB Dongle**

Communication System: UID 0, CW (0); Frequency: 2402 MHz; Duty Cycle: 1:1  
Medium parameters used (interpolated):  $f = 2402$  MHz;  $\sigma = 1.901$  S/m;  $\epsilon_r = 50.355$ ;  $\rho = 1000$  kg/m<sup>3</sup> ;  
Phantom section: Flat Section ; Measurement Standard: DASYS (IEEE/IEC/ANSI C63.19-2011)

DASY Configuration:

- Probe: EX3DV4 - SN3673; ConvF(7.48, 7.48, 7.48); Calibrated: 8/30/2022;
- Sensor-Surface: 1.4mm (Mechanical Surface Detection)
- Electronics: DAE4 Sn874; Calibrated: 8/25/2022
- Phantom: ELI 4.0; Type: QD OVA 001 BB; Serial: 1057
- DASYS 52.10.0(1446); SEMCAD X 14.6.10(7417)

**DIGI-194Q Body/Vertical Back d= 5mm/Area Scan (31x81x1):** Interpolated grid: dx=1.500 mm, dy=1.500 mm

Maximum value of SAR (interpolated) = 0.0976 W/kg

**DIGI-194Q Body/Vertical Back d= 5mm/Zoom Scan (5x5x7) (5x5x7)/Cube 0:**

Measurement grid: dx=7.5mm, dy=7.5mm, dz=5mm

Reference Value = 2.791 V/m; Power Drift = 0.31 dB

Peak SAR (extrapolated) = 0.133 W/kg

**SAR(1 g) = 0.067 W/kg; SAR(10 g) = 0.038 W/kg** (SAR corrected for target medium)

Maximum value of SAR (measured) = 0.103 W/kg

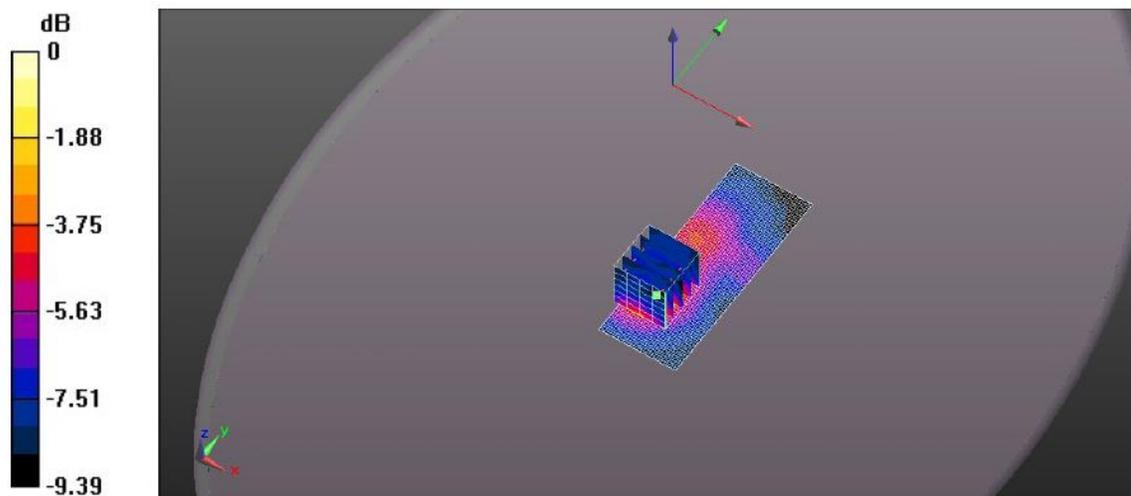

0 dB = 0.0976 W/kg = -10.10 dBW/kg

**FILE NAME:** [DIGI-194Q 2440 MHZ BLE BODY D 5MM VERTICAL BACK.DA52:0](#)

**DUT: DIGI XBPRR with BLE (1 Mbps); Type: USB Dongle**

Communication System: UID 0, CW (0); Frequency: 2440 MHz; Duty Cycle: 1:1  
Medium parameters used (interpolated):  $f = 2440$  MHz;  $\sigma = 1.95$  S/m;  $\epsilon_r = 50.204$ ;  $\rho = 1000$  kg/m<sup>3</sup> ;  
Phantom section: Flat Section ; Measurement Standard: DASYS (IEEE/IEC/ANSI C63.19-2011)

DASY Configuration:

- Probe: EX3DV4 - SN3673; ConvF(7.48, 7.48, 7.48); Calibrated: 8/30/2022;
- Sensor-Surface: 1.4mm (Mechanical Surface Detection)
- Electronics: DAE4 Sn874; Calibrated: 8/25/2022
- Phantom: ELI 4.0; Type: QD OVA 001 BB; Serial: 1057
- DASYS2 52.10.0(1446); SEMCAD X 14.6.10(7417)

**DIGI-194Q Body/Vertical Back d= 5mm/Area Scan (41x81x1):** Interpolated grid: dx=1.500 mm, dy=1.500 mm

Maximum value of SAR (interpolated) = 0.0895 W/kg

**DIGI-194Q Body/Vertical Back d= 5mm/Zoom Scan (5x5x7) (5x5x7)/Cube 0:**

Measurement grid: dx=7.5mm, dy=7.5mm, dz=5mm

Reference Value = 3.549 V/m; Power Drift = -1.09 dB

Peak SAR (extrapolated) = 0.139 W/kg

**SAR(1 g) = 0.065 W/kg; SAR(10 g) = 0.037 W/kg** (SAR corrected for target medium)

Maximum value of SAR (measured) = 0.105 W/kg

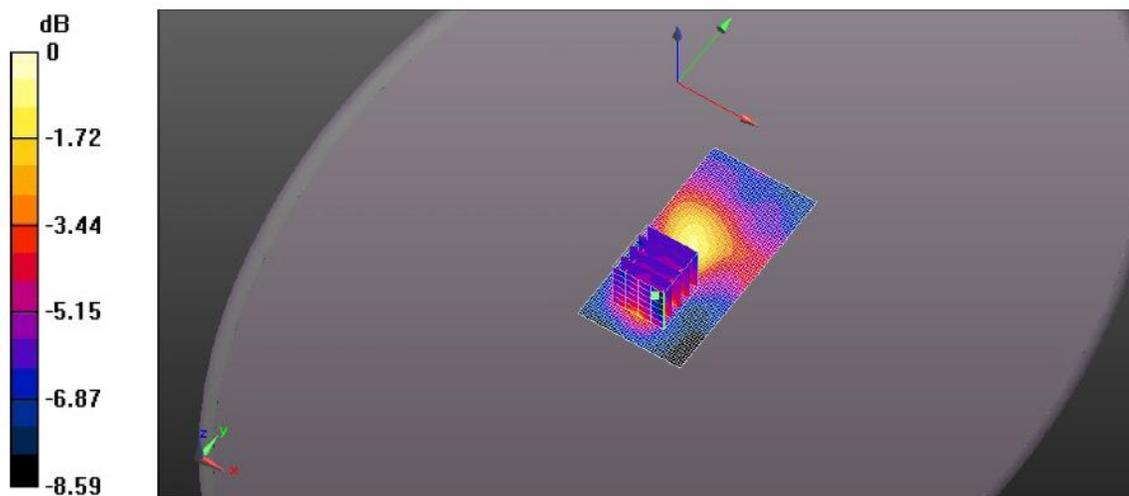

0 dB = 0.0895 W/kg = -10.48 dBW/kg



**FILE NAME:** [DIGI-194Q 2480 MHZ BLE BODY D 5MM VERTICAL BACK.DA52:0](#)

**DUT: DIGI XBPRR with BLE (1 Mbps); Type: USB Dongle**

Communication System: UID 0, CW (0); Frequency: 2480 MHz; Duty Cycle: 1:1  
Medium parameters used (interpolated):  $f = 2480$  MHz;  $\sigma = 1.999$  S/m;  $\epsilon_r = 50.059$ ;  $\rho = 1000$  kg/m<sup>3</sup> ;  
Phantom section: Flat Section ; Measurement Standard: DASYS (IEEE/IEC/ANSI C63.19-2011)

DASY Configuration:

- Probe: EX3DV4 - SN3673; ConvF(7.48, 7.48, 7.48); Calibrated: 8/30/2022;
- Sensor-Surface: 1.4mm (Mechanical Surface Detection)
- Electronics: DAE4 Sn874; Calibrated: 8/25/2022
- Phantom: ELI 4.0; Type: QD OVA 001 BB; Serial: 1057
- DASYS2 52.10.0(1446); SEMCAD X 14.6.10(7417)

**DIGI-194Q Body/Vertical Back d= 5mm/Area Scan (41x81x1):** Interpolated grid: dx=1.500 mm, dy=1.500 mm

Maximum value of SAR (interpolated) = 0.105 W/kg

**DIGI-194Q Body/Vertical Back d= 5mm/Zoom Scan (5x5x7) (5x5x7)/Cube 0:**

Measurement grid: dx=7.5mm, dy=7.5mm, dz=5mm

Reference Value = 3.298 V/m; Power Drift = 0.16 dB

Peak SAR (extrapolated) = 0.169 W/kg

**SAR(1 g) = 0.073 W/kg; SAR(10 g) = 0.040 W/kg** (SAR corrected for target medium)

Maximum value of SAR (measured) = 0.118 W/kg

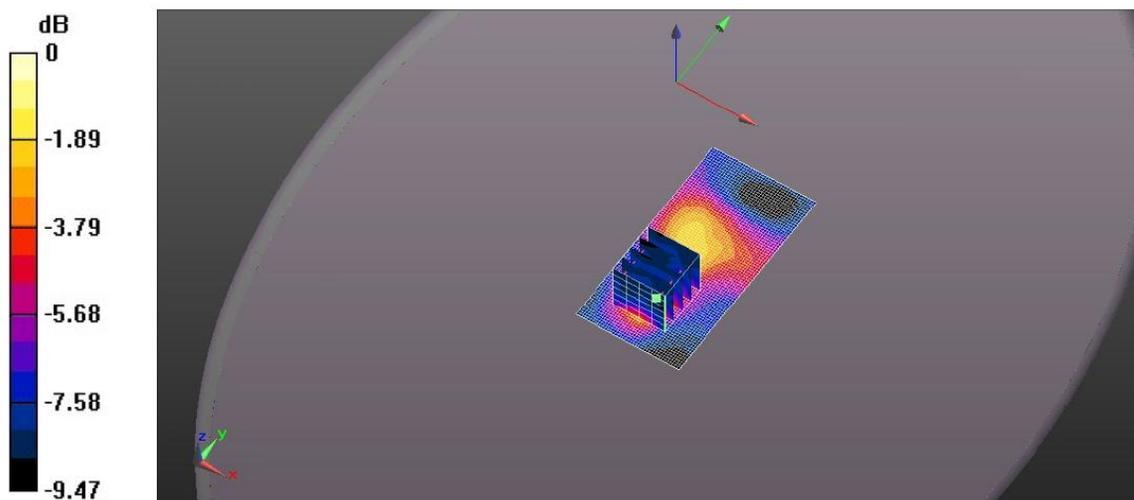

0 dB = 0.105 W/kg = -9.80 dBW/kg

**FILE NAME:** [DIGI-194Q 2402 MHZ BLE BODY D 5MM HORIZONTAL UP.DA52:0](#)

**DUT: DIGI XBPRR with BLE(1 Mbps); Type: USB Dongle**

Communication System: UID 0, CW (0); Frequency: 2402 MHz; Duty Cycle: 1:1  
Medium parameters used (interpolated):  $f = 2402$  MHz;  $\sigma = 1.901$  S/m;  $\epsilon_r = 50.355$ ;  $\rho = 1000$  kg/m<sup>3</sup> ;  
Phantom section: Flat Section ; Measurement Standard: DASYS (IEEE/IEC/ANSI C63.19-2011)

DASY Configuration:

- Probe: EX3DV4 - SN3673; ConvF(7.48, 7.48, 7.48); Calibrated: 8/30/2022;
- Sensor-Surface: 1.4mm (Mechanical Surface Detection)
- Electronics: DAE4 Sn874; Calibrated: 8/25/2022
- Phantom: ELI 4.0; Type: QD OVA 001 BB; Serial: 1057
- DASYS 52.10.0(1446); SEMCAD X 14.6.10(7417)

**DIGI-194Q Body/Horizontal Up d= 5mm/Area Scan (41x81x1):** Interpolated grid: dx=1.500 mm, dy=1.500 mm

Maximum value of SAR (interpolated) = 0.129 W/kg

**DIGI-194Q Body/Horizontal Up d= 5mm/Zoom Scan (5x5x7) (6x6x7)/Cube 0:**

Measurement grid: dx=7.5mm, dy=7.5mm, dz=5mm

Reference Value = 6.020 V/m; Power Drift = 0.08 dB

Peak SAR (extrapolated) = 0.149 W/kg

**SAR(1 g) = 0.084 W/kg; SAR(10 g) = 0.050 W/kg** (SAR corrected for target medium)

Maximum value of SAR (measured) = 0.050 W/kg

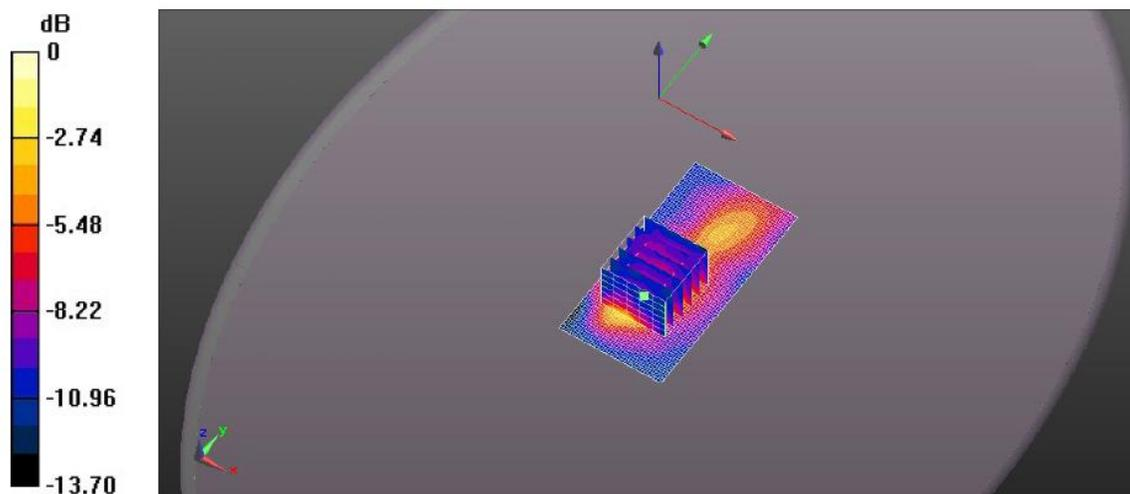

0 dB = 0.129 W/kg = -8.91 dBW/kg

**FILE NAME:** [DIGI-194Q 2440 MHZ BLE BODY D 5MM HORIZONTAL UP.DA52:0](#)

**DUT: DIGI XBPRR with BLE (1 Mbps); Type: USB Dongle**

Communication System: UID 0, CW (0); Frequency: 2440 MHz; Duty Cycle: 1:1  
Medium parameters used (interpolated):  $f = 2440$  MHz;  $\sigma = 1.95$  S/m;  $\epsilon_r = 50.204$ ;  $\rho = 1000$  kg/m<sup>3</sup> ;  
Phantom section: Flat Section ; Measurement Standard: DASYS (IEEE/IEC/ANSI C63.19-2011)

DASY Configuration:

- Probe: EX3DV4 - SN3673; ConvF(7.48, 7.48, 7.48); Calibrated: 8/30/2022;
- Sensor-Surface: 1.4mm (Mechanical Surface Detection)
- Electronics: DAE4 Sn874; Calibrated: 8/25/2022
- Phantom: ELI 4.0; Type: QD OVA 001 BB; Serial: 1057
- DASYS 52.10.0(1446); SEMCAD X 14.6.10(7417)

**DIGI-194Q Body/Horizontal Up d= 5mm/Area Scan (41x81x1):** Interpolated grid: dx=1.500 mm, dy=1.500 mm

Maximum value of SAR (interpolated) = 0.126 W/kg

**DIGI-194Q Body/Horizontal Up d= 5mm/Zoom Scan (5x5x7) (5x5x7)/Cube 0:**

Measurement grid: dx=7.5mm, dy=7.5mm, dz=5mm

Reference Value = 4.416 V/m; Power Drift = 0.28 dB

Peak SAR (extrapolated) = 0.131 W/kg

**SAR(1 g) = 0.076 W/kg; SAR(10 g) = 0.046 W/kg** (SAR corrected for target medium)

Maximum value of SAR (measured) = 0.107 W/kg

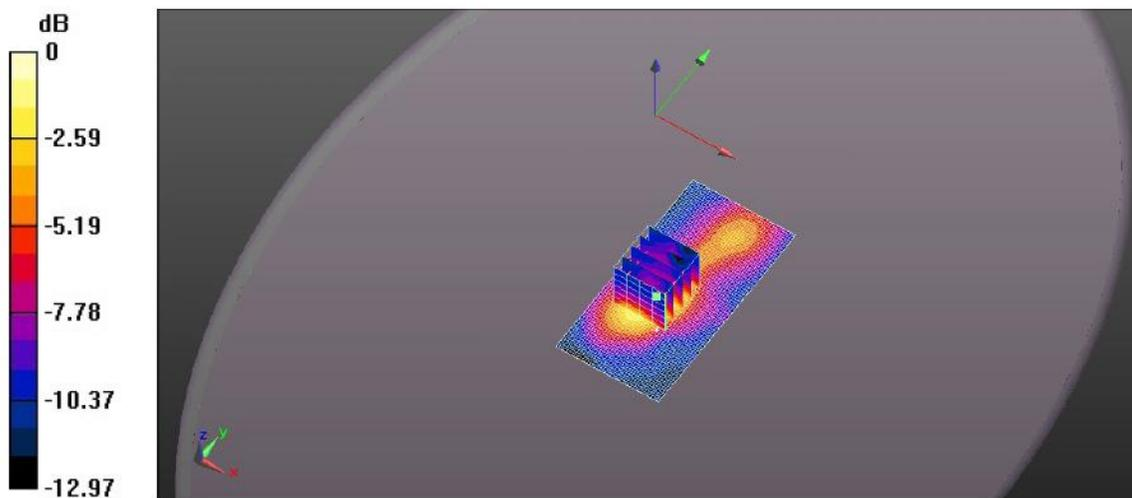

0 dB = 0.126 W/kg = -9.01 dBW/kg

**FILE NAME:** [DIGI-194Q 2480 MHZ BLE BODY D 5MM HORIZONTAL UP.DA52:0](#)

**DUT: DIGI XBPRR with BLE (1 Mbps); Type: USB Dongle**

Communication System: UID 0, CW (0); Frequency: 2480 MHz; Duty Cycle: 1:1  
Medium parameters used (interpolated):  $f = 2480$  MHz;  $\sigma = 1.999$  S/m;  $\epsilon_r = 50.059$ ;  $\rho = 1000$  kg/m<sup>3</sup> ;  
Phantom section: Flat Section ; Measurement Standard: DASYS (IEEE/IEC/ANSI C63.19-2011)

DASY Configuration:

- Probe: EX3DV4 - SN3673; ConvF(7.48, 7.48, 7.48); Calibrated: 8/30/2022;
- Sensor-Surface: 1.4mm (Mechanical Surface Detection)
- Electronics: DAE4 Sn874; Calibrated: 8/25/2022
- Phantom: ELI 4.0; Type: QD OVA 001 BB; Serial: 1057
- DASYS 52.10.0(1446); SEMCAD X 14.6.10(7417)

**DIGI-194Q Body/Horizontal Up d= 5mm/Area Scan (31x81x1):** Interpolated grid: dx=1.500 mm, dy=1.500 mm

Maximum value of SAR (interpolated) = 0.189 W/kg

**DIGI-194Q Body/Horizontal Up d= 5mm/Zoom Scan (5x5x7) (5x5x7)/Cube 0:**

Measurement grid: dx=7.5mm, dy=7.5mm, dz=5mm

Reference Value = 7.606 V/m; Power Drift = 0.07 dB

Peak SAR (extrapolated) = 0.216 W/kg

**SAR(1 g) = 0.117 W/kg; SAR(10 g) = 0.066 W/kg** (SAR corrected for target medium)

Maximum value of SAR (measured) = 0.175 W/kg

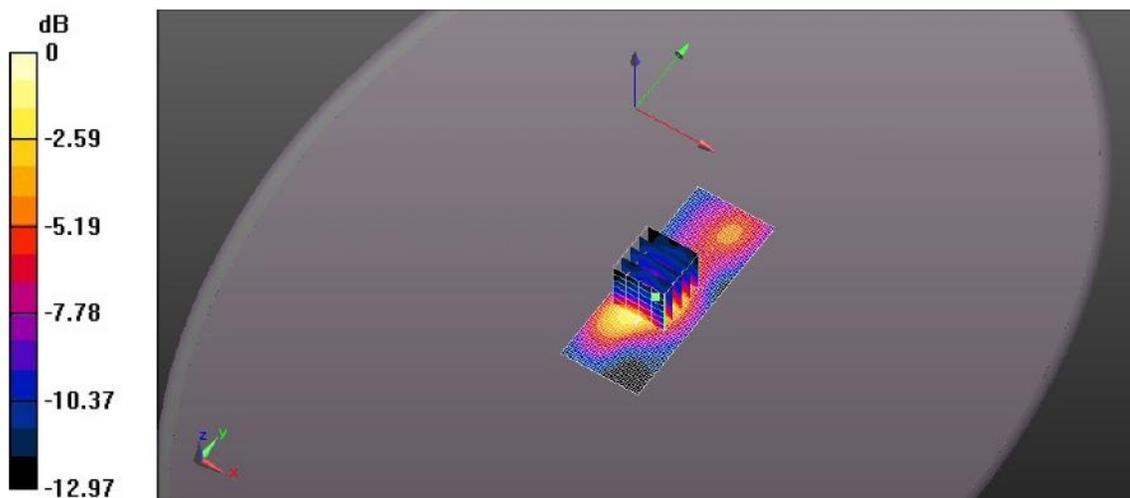

0 dB = 0.189 W/kg = -7.24 dBW/kg

**FILE NAME:** [DIGI-194Q 2402 MHZ BLE BODY D 5MM HORIZONTAL DOWN.DA52:0](#)

**DUT: DIGI XBPRR with BLE (1 Mbps); Type: USB Dongle**

Communication System: UID 0, CW (0); Frequency: 2402 MHz; Duty Cycle: 1:1  
Medium parameters used (interpolated):  $f = 2402$  MHz;  $\sigma = 1.901$  S/m;  $\epsilon_r = 50.355$ ;  $\rho = 1000$  kg/m<sup>3</sup> ;  
Phantom section: Flat Section ; Measurement Standard: DASYS (IEEE/IEC/ANSI C63.19-2011)

DASY Configuration:

- Probe: EX3DV4 - SN3673; ConvF(7.48, 7.48, 7.48); Calibrated: 8/30/2022;
- Sensor-Surface: 1.4mm (Mechanical Surface Detection)
- Electronics: DAE4 Sn874; Calibrated: 8/25/2022
- Phantom: ELI 4.0; Type: QD OVA 001 BB; Serial: 1057
- DASYS 52.10.0(1446); SEMCAD X 14.6.10(7417)

**DIGI-194Q Body/Horizontal Down d= 5mm/Area Scan (31x81x1):** Interpolated grid:  
dx=1.500 mm, dy=1.500 mm  
Maximum value of SAR (interpolated) = 0.175 W/kg

**DIGI-194Q Body/Horizontal Down d= 5mm/Zoom Scan (5x5x7) (5x5x7)/Cube 0:**  
Measurement grid: dx=7.5mm, dy=7.5mm, dz=5mm  
Reference Value = 4.552 V/m; Power Drift = 0.29 dB  
Peak SAR (extrapolated) = 0.215 W/kg  
**SAR(1 g) = 0.129 W/kg; SAR(10 g) = 0.088 W/kg** (SAR corrected for target medium)  
Maximum value of SAR (measured) = 0.178 W/kg

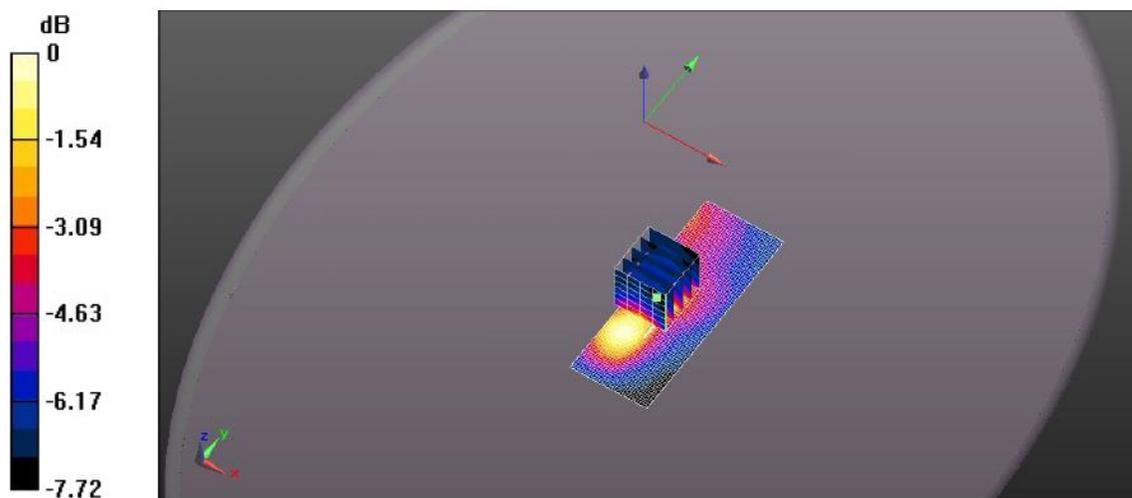

0 dB = 0.175 W/kg = -7.56 dBW/kg

**FILE NAME:** [DIGI-194Q 2440 MHZ BLE BODY D 5MM HORIZONTAL DOWN.DA52:0](#)

**DUT: DIGI XBPRR with BLE (1 Mbps); Type: USB Dongle**

Communication System: UID 0, CW (0); Frequency: 2440 MHz; Duty Cycle: 1:1  
Medium parameters used (interpolated):  $f = 2440$  MHz;  $\sigma = 1.95$  S/m;  $\epsilon_r = 50.204$ ;  $\rho = 1000$  kg/m<sup>3</sup> ;  
Phantom section: Flat Section ; Measurement Standard: DASYS (IEEE/IEC/ANSI C63.19-2011)

DASY Configuration:

- Probe: EX3DV4 - SN3673; ConvF(7.48, 7.48, 7.48); Calibrated: 8/30/2022;
- Sensor-Surface: 1.4mm (Mechanical Surface Detection)
- Electronics: DAE4 Sn874; Calibrated: 8/25/2022
- Phantom: ELI 4.0; Type: QD OVA 001 BB; Serial: 1057
- DASYS 52.10.0(1446); SEMCAD X 14.6.10(7417)

**DIGI-194Q Body/Horizontal Down d= 5mm/Area Scan (31x81x1):** Interpolated grid:  
dx=1.500 mm, dy=1.500 mm  
Maximum value of SAR (interpolated) = 0.173 W/kg

**DIGI-194Q Body/Horizontal Down d= 5mm/Zoom Scan (5x5x7) (5x5x7)/Cube 0:**  
Measurement grid: dx=7.5mm, dy=7.5mm, dz=5mm  
Reference Value = 2.677 V/m; Power Drift = 0.27 dB  
Peak SAR (extrapolated) = 0.220 W/kg  
**SAR(1 g) = 0.118 W/kg; SAR(10 g) = 0.068 W/kg** (SAR corrected for target medium)  
Maximum value of SAR (measured) = 0.179 W/kg

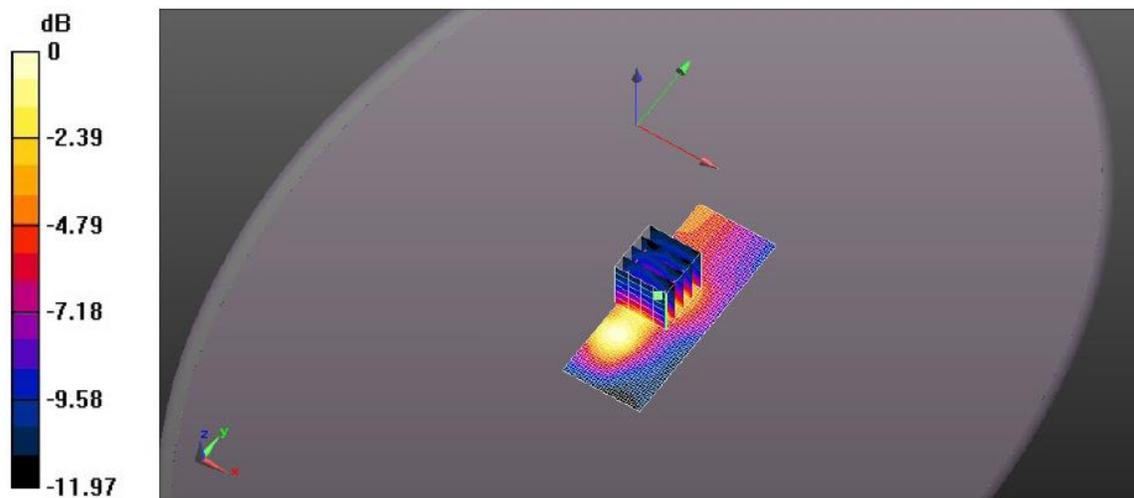

0 dB = 0.173 W/kg = -7.61 dBW/kg

**FILE NAME:** [DIGI-194Q 2480 MHZ BLE BODY D 5MM HORIZONTAL DOWN.DA52:0](#)

**DUT: DIGI XBPRR with BLE (1 Mbps); Type: USB Dongle**

Communication System: UID 0, CW (0); Frequency: 2480 MHz; Duty Cycle: 1:1  
Medium parameters used (interpolated):  $f = 2480$  MHz;  $\sigma = 1.999$  S/m;  $\epsilon_r = 50.059$ ;  $\rho = 1000$  kg/m<sup>3</sup> ;  
Phantom section: Flat Section ; Measurement Standard: DASYS (IEEE/IEC/ANSI C63.19-2011)

DASY Configuration:

- Probe: EX3DV4 - SN3673; ConvF(7.48, 7.48, 7.48); Calibrated: 8/30/2022;
- Sensor-Surface: 1.4mm (Mechanical Surface Detection)
- Electronics: DAE4 Sn874; Calibrated: 8/25/2022
- Phantom: ELI 4.0; Type: QD OVA 001 BB; Serial: 1057
- DASYS 52.10.0(1446); SEMCAD X 14.6.10(7417)

**DIGI-194Q Body/Horizontal Down d= 5mm/Area Scan (41x81x1):** Interpolated grid:  
dx=1.500 mm, dy=1.500 mm  
Maximum value of SAR (interpolated) = 0.171 W/kg

**DIGI-194Q Body/Horizontal Down d= 5mm/Zoom Scan (5x5x7) (5x5x7)/Cube 0:**  
Measurement grid: dx=7.5mm, dy=7.5mm, dz=5mm  
Reference Value = 4.230 V/m; Power Drift = -0.16 dB  
Peak SAR (extrapolated) = 0.213 W/kg  
**SAR(1 g) = 0.102 W/kg; SAR(10 g) = 0.055 W/kg** (SAR corrected for target medium)  
Maximum value of SAR (measured) = 0.160 W/kg

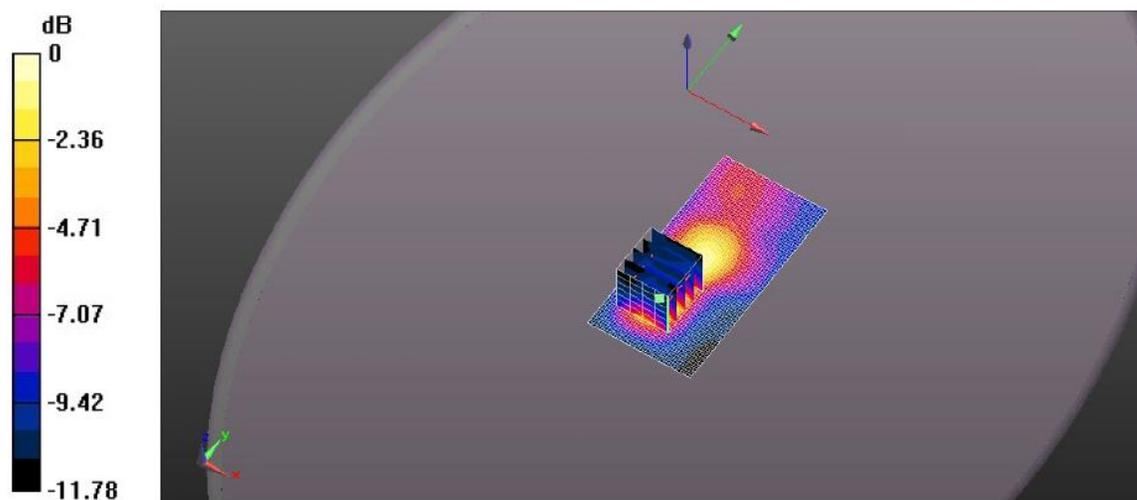

0 dB = 0.171 W/kg = -7.67 dBW/kg

**FILE NAME:** [DIGI-194Q 2402 MHZ BLE BODY D 5MM TIP MODE.DA52:0](#)

**DUT: DIGI XBPRR with BLE (1 Mbps); Type: USB Dongle**

Communication System: UID 0, CW (0); Frequency: 2402 MHz; Duty Cycle: 1:1  
Medium parameters used (interpolated):  $f = 2402$  MHz;  $\sigma = 1.901$  S/m;  $\epsilon_r = 50.355$ ;  $\rho = 1000$  kg/m<sup>3</sup> ;  
Phantom section: Flat Section ; Measurement Standard: DASYS (IEEE/IEC/ANSI C63.19-2011)

DASY Configuration:

- Probe: EX3DV4 - SN3673; ConvF(7.48, 7.48, 7.48); Calibrated: 8/30/2022;
- Sensor-Surface: 1.4mm (Mechanical Surface Detection)
- Electronics: DAE4 Sn874; Calibrated: 8/25/2022
- Phantom: ELI 4.0; Type: QD OVA 001 BB; Serial: 1057
- DASYS2 52.10.0(1446); SEMCAD X 14.6.10(7417)

**DIGI-194Q Body/Tip Mode d= 5mm/Area Scan (41x51x1):** Interpolated grid: dx=1.500 mm, dy=1.500 mm

Maximum value of SAR (interpolated) = 0.00708 W/kg

**DIGI-194Q Body/Tip Mode d= 5mm/Zoom Scan (5x5x7) (7x6x7)/Cube 0:** Measurement grid: dx=7.5mm, dy=7.5mm, dz=5mm

Reference Value = 0.9790 V/m; Power Drift = 0.79 dB

Peak SAR (extrapolated) = 0.0120 W/kg

**SAR(1 g) = 0.00617 W/kg; SAR(10 g) = 0.00435 W/kg** (SAR corrected for target medium)

Maximum value of SAR (measured) = 0.0101 W/kg

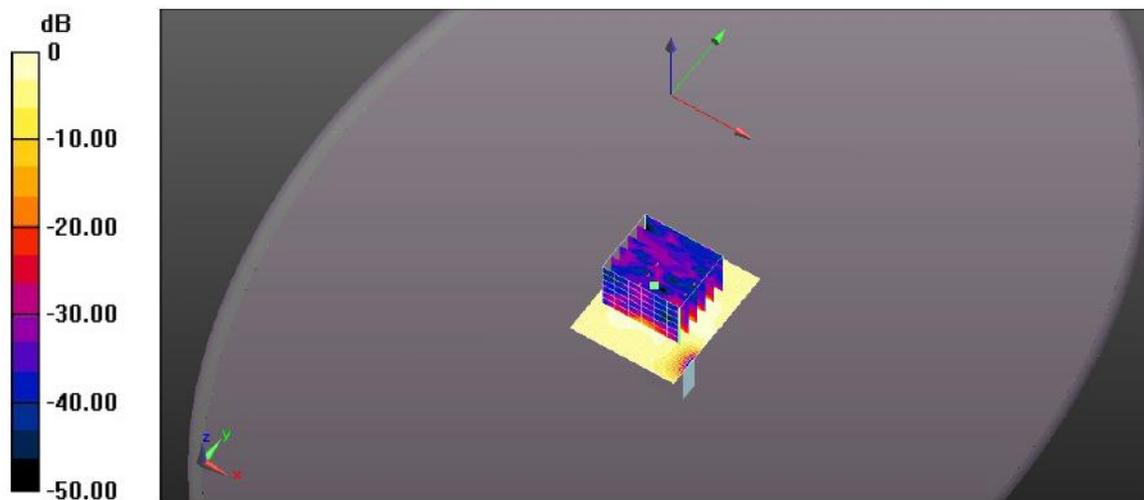

0 dB = 0.00708 W/kg = -21.50 dBW/kg



**FILE NAME:** [DIGI-194Q 2440 MHZ BLE BODY D 5MM TIP MODE.DA52:0](#)

**DUT: DIGI XBPRR with BLE (1 Mbps); Type: USB Dongle**

Communication System: UID 0, CW (0); Frequency: 2440 MHz; Duty Cycle: 1:1  
Medium parameters used (interpolated):  $f = 2440$  MHz;  $\sigma = 1.95$  S/m;  $\epsilon_r = 50.204$ ;  $\rho = 1000$  kg/m<sup>3</sup> ;  
Phantom section: Flat Section ; Measurement Standard: DASYS (IEEE/IEC/ANSI C63.19-2011)

DASY Configuration:

- Probe: EX3DV4 - SN3673; ConvF(7.48, 7.48, 7.48); Calibrated: 8/30/2022;
- Sensor-Surface: 1.4mm (Mechanical Surface Detection)
- Electronics: DAE4 Sn874; Calibrated: 8/25/2022
- Phantom: ELI 4.0; Type: QD OVA 001 BB; Serial: 1057
- DASYS 52.10.0(1446); SEMCAD X 14.6.10(7417)

**DIGI-194Q Body/Tip Mode d= 5mm/Area Scan (41x51x1):** Interpolated grid: dx=1.500 mm, dy=1.500 mm

Maximum value of SAR (interpolated) = 0.0104 W/kg

**DIGI-194Q Body/Tip Mode d= 5mm/Zoom Scan (5x5x7) (6x6x7)/Cube 0:** Measurement grid: dx=7.5mm, dy=7.5mm, dz=5mm

Reference Value = 1.097 V/m; Power Drift = -0.26 dB

Peak SAR (extrapolated) = 0.0120 W/kg

**SAR(1 g) = 0.00696 W/kg; SAR(10 g) = 0.00486 W/kg** (SAR corrected for target medium)

Maximum value of SAR (measured) = 0.00950 W/kg

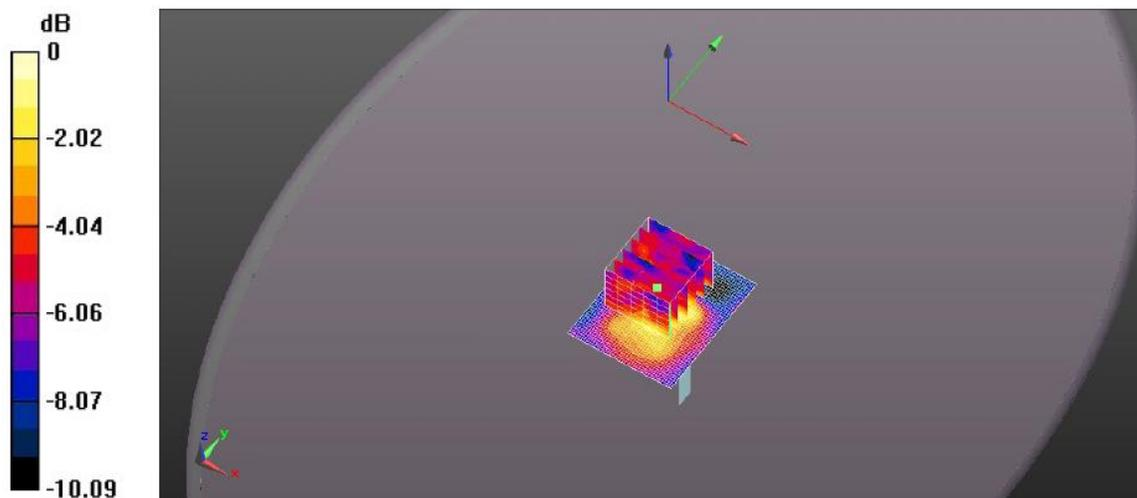

0 dB = 0.0104 W/kg = -19.83 dBW/kg

**FILE NAME:** [DIGI-194Q 2480 MHZ BLE BODY D 5MM TIP MODE.DA52:0](#)

**DUT: DIGI XBPRR with BLE (1 Mbps); Type: USB Dongle**

Communication System: UID 0, CW (0); Frequency: 2480 MHz; Duty Cycle: 1:1  
Medium parameters used (interpolated):  $f = 2480$  MHz;  $\sigma = 1.999$  S/m;  $\epsilon_r = 50.059$ ;  $\rho = 1000$  kg/m<sup>3</sup> ;  
Phantom section: Flat Section ; Measurement Standard: DASYS (IEEE/IEC/ANSI C63.19-2011)

DASY Configuration:

- Probe: EX3DV4 - SN3673; ConvF(7.48, 7.48, 7.48); Calibrated: 8/30/2022;
- Sensor-Surface: 1.4mm (Mechanical Surface Detection)
- Electronics: DAE4 Sn874; Calibrated: 8/25/2022
- Phantom: ELI 4.0; Type: QD OVA 001 BB; Serial: 1057
- DASYS2 52.10.0(1446); SEMCAD X 14.6.10(7417)

**DIGI-194Q Body/Tip Mode d= 5mm/Area Scan (31x51x1):** Interpolated grid: dx=1.500 mm, dy=1.500 mm

Maximum value of SAR (interpolated) = 0.0162 W/kg

**DIGI-194Q Body/Tip Mode d= 5mm/Zoom Scan (5x5x7) (6x6x7)/Cube 0:** Measurement grid: dx=7.5mm, dy=7.5mm, dz=5mm

Reference Value = 1.268 V/m; Power Drift = -0.82 dB

Peak SAR (extrapolated) = 0.0210 W/kg

**SAR(1 g) = 0.011 W/kg; SAR(10 g) = 0.00685 W/kg** (SAR corrected for target medium)

Maximum value of SAR (measured) = 0.0156 W/kg

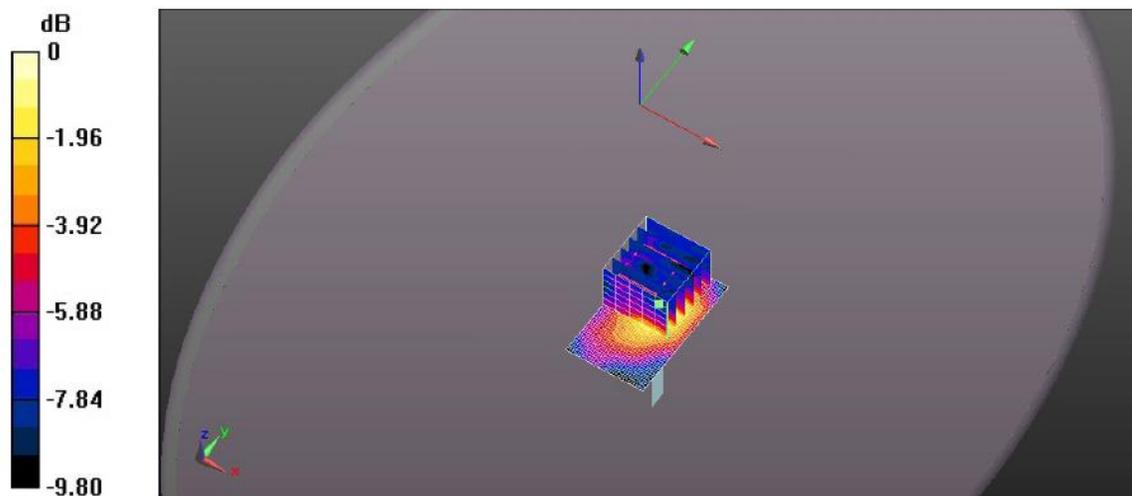

0 dB = 0.0162 W/kg = -17.90 dBW/kg

## EXHIBIT 4. BLE (2 MBPS) BODY MEASUREMENTS

**FILE NAME:** [DIGI-194Q 2404 MHZ BLE \(2MBPS\) BODY D 5MM VERTICAL FRONT.DA52:0](#)

**DUT: DIGI XBPRR with BLE (2 Mbps); Type: USB Dongle**

Communication System: UID 0, CW (0); Frequency: 2404 MHz; Duty Cycle: 1:1  
Medium parameters used (interpolated):  $f = 2404$  MHz;  $\sigma = 1.861$  S/m;  $\epsilon_r = 50.679$ ;  $\rho = 1000$  kg/m<sup>3</sup> ;  
Phantom section: Flat Section ; Measurement Standard: DASYS (IEEE/IEC/ANSI C63.19-2011)

DASY Configuration:

- Probe: EX3DV4 - SN3673; ConvF(7.48, 7.48, 7.48); Calibrated: 8/30/2022;
- Sensor-Surface: 1.4mm (Mechanical Surface Detection)
- Electronics: DAE4 Sn874; Calibrated: 8/25/2022
- Phantom: ELI 4.0; Type: QD OVA 001 BB; Serial: 1057
- DASYS 52.10.0(1446); SEMCAD X 14.6.10(7417)

**DIGI-194Q Body/Vertical Front d= 5mm/Area Scan (41x81x1):** Interpolated grid: dx=1.500 mm, dy=1.500 mm

Maximum value of SAR (interpolated) = 0.172 W/kg

**DIGI-194Q Body/Vertical Front d= 5mm/Zoom Scan (5x5x7) (7x6x7)/Cube 0:**

Measurement grid: dx=7.5mm, dy=7.5mm, dz=5mm

Reference Value = 3.048 V/m; Power Drift = -0.59 dB

Peak SAR (extrapolated) = 0.213 W/kg

**SAR(1 g) = 0.110 W/kg; SAR(10 g) = 0.058 W/kg** (SAR corrected for target medium)

Maximum value of SAR (measured) = 0.172 W/kg

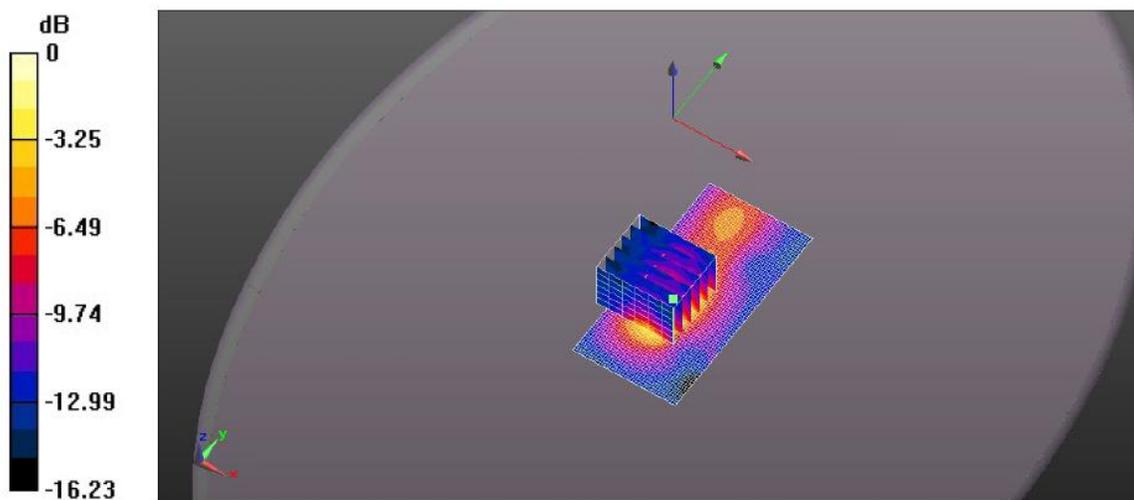

0 dB = 0.172 W/kg = -7.65 dBW/kg

**FILE NAME:** [DIGI-194Q 2440 MHZ BLE \(2MBPS\) BODY D 5MM VERTICAL FRONT.DA52:0](#)

**DUT: DIGI XBPRR with BLE (2 Mbps); Type: USB Dongle**

Communication System: UID 0, CW (0); Frequency: 2440 MHz; Duty Cycle: 1:1  
Medium parameters used (interpolated):  $f = 2440$  MHz;  $\sigma = 1.903$  S/m;  $\epsilon_r = 50.536$ ;  $\rho = 1000$  kg/m<sup>3</sup> ;  
Phantom section: Flat Section ; Measurement Standard: DASYS (IEEE/IEC/ANSI C63.19-2011)

DASY Configuration:

- Probe: EX3DV4 - SN3673; ConvF(7.48, 7.48, 7.48); Calibrated: 8/30/2022;
- Sensor-Surface: 1.4mm (Mechanical Surface Detection)
- Electronics: DAE4 Sn874; Calibrated: 8/25/2022
- Phantom: ELI 4.0; Type: QD OVA 001 BB; Serial: 1057
- DASYS 52.10.0(1446); SEMCAD X 14.6.10(7417)

**DIGI-194Q Body/Vertical Front d= 5mm/Area Scan (41x81x1):** Interpolated grid: dx=1.500 mm, dy=1.500 mm

Maximum value of SAR (interpolated) = 0.227 W/kg

**DIGI-194Q Body/Vertical Front d= 5mm/Zoom Scan (5x5x7) (7x6x7)/Cube 0:**

Measurement grid: dx=7.5mm, dy=7.5mm, dz=5mm

Reference Value = 3.864 V/m; Power Drift = -0.71 dB

Peak SAR (extrapolated) = 0.299 W/kg

**SAR(1 g) = 0.149 W/kg; SAR(10 g) = 0.077 W/kg** (SAR corrected for target medium)

Maximum value of SAR (measured) = 0.239 W/kg

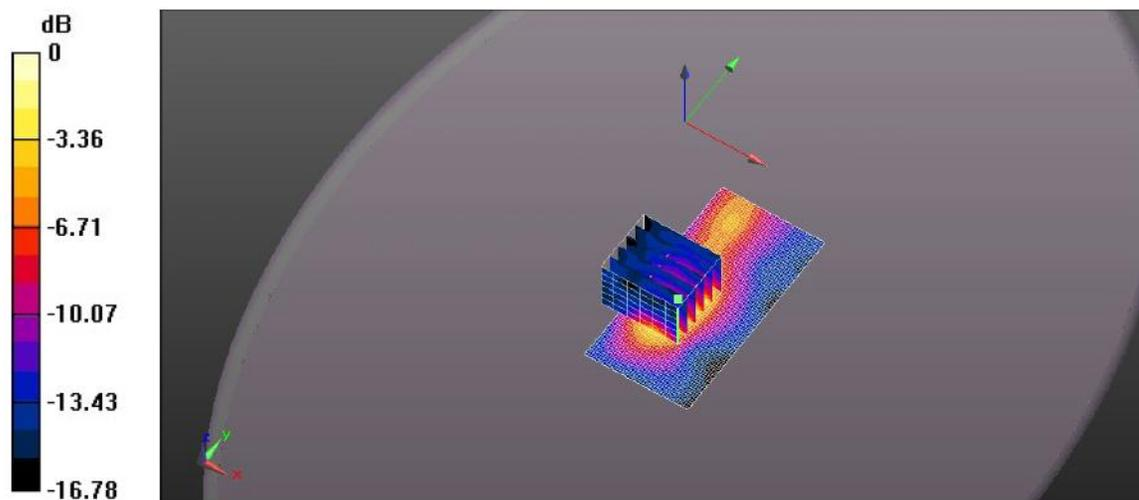

0 dB = 0.227 W/kg = -6.44 dBW/kg

**FILE NAME:** [DIGI-194Q 2478 MHZ BLE \(2MBPS\) BODY D 5MM VERTICAL FRONT.DA52:0](#)

**DUT: DIGI XBPRR with BLE (2 Mbps); Type: USB Dongle**

Communication System: UID 0, CW (0); Frequency: 2478 MHz; Duty Cycle: 1:1  
Medium parameters used (interpolated):  $f = 2478$  MHz;  $\sigma = 1.952$  S/m;  $\epsilon_r = 50.376$ ;  $\rho = 1000$  kg/m<sup>3</sup> ;  
Phantom section: Flat Section ; Measurement Standard: DASYS (IEEE/IEC/ANSI C63.19-2011)

DASY Configuration:

- Probe: EX3DV4 - SN3673; ConvF(7.48, 7.48, 7.48); Calibrated: 8/30/2022;
- Sensor-Surface: 1.4mm (Mechanical Surface Detection)
- Electronics: DAE4 Sn874; Calibrated: 8/25/2022
- Phantom: ELI 4.0; Type: QD OVA 001 BB; Serial: 1057
- DASYS 52.10.0(1446); SEMCAD X 14.6.10(7417)

**DIGI-194Q Body/Vertical Front d= 5mm/Area Scan (41x81x1):** Interpolated grid: dx=1.500 mm, dy=1.500 mm

Maximum value of SAR (interpolated) = 0.136 W/kg

**DIGI-194Q Body/Vertical Front d= 5mm/Zoom Scan (5x5x7) (7x6x7)/Cube 0:**

Measurement grid: dx=7.5mm, dy=7.5mm, dz=5mm

Reference Value = 2.575 V/m; Power Drift = -0.35 dB

Peak SAR (extrapolated) = 0.181 W/kg

**SAR(1 g) = 0.090 W/kg; SAR(10 g) = 0.049 W/kg** (SAR corrected for target medium)

Maximum value of SAR (measured) = 0.144 W/kg

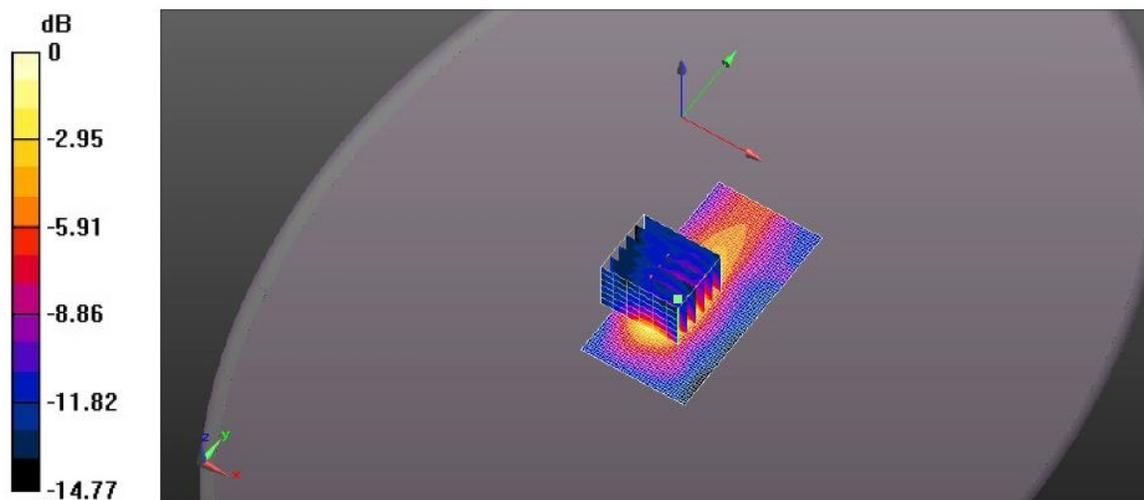

0 dB = 0.136 W/kg = -8.66 dBW/kg

**FILE NAME:** [DIGI-194Q 2404 MHZ BLE \(2MBPS\) BODY D 5MM VERTICAL BACK.DA52:0](#)

**DUT: DIGI XBPRR with BLE (2 Mbps); Type: USB Dongle**

Communication System: UID 0, CW (0); Frequency: 2404 MHz; Duty Cycle: 1:1  
Medium parameters used (interpolated):  $f = 2404$  MHz;  $\sigma = 1.861$  S/m;  $\epsilon_r = 50.679$ ;  $\rho = 1000$  kg/m<sup>3</sup> ;  
Phantom section: Flat Section ; Measurement Standard: DASYS (IEEE/IEC/ANSI C63.19-2011)

DASY Configuration:

- Probe: EX3DV4 - SN3673; ConvF(7.48, 7.48, 7.48); Calibrated: 8/30/2022;
- Sensor-Surface: 1.4mm (Mechanical Surface Detection)
- Electronics: DAE4 Sn874; Calibrated: 8/25/2022
- Phantom: ELI 4.0; Type: QD OVA 001 BB; Serial: 1057
- DASYS 52.10.0(1446); SEMCAD X 14.6.10(7417)

**DIGI-194Q Body/Vertical Back d= 5mm/Area Scan (41x81x1):** Interpolated grid: dx=1.500 mm, dy=1.500 mm

Maximum value of SAR (interpolated) = 0.196 W/kg

**DIGI-194Q Body/Vertical Back d= 5mm/Zoom Scan (5x5x7) (7x6x7)/Cube 0:**

Measurement grid: dx=7.5mm, dy=7.5mm, dz=5mm

Reference Value = 2.992 V/m; Power Drift = 0.42 dB

Peak SAR (extrapolated) = 0.303 W/kg

**SAR(1 g) = 0.130 W/kg; SAR(10 g) = 0.063 W/kg** (SAR corrected for target medium)

Maximum value of SAR (measured) = 0.216 W/kg

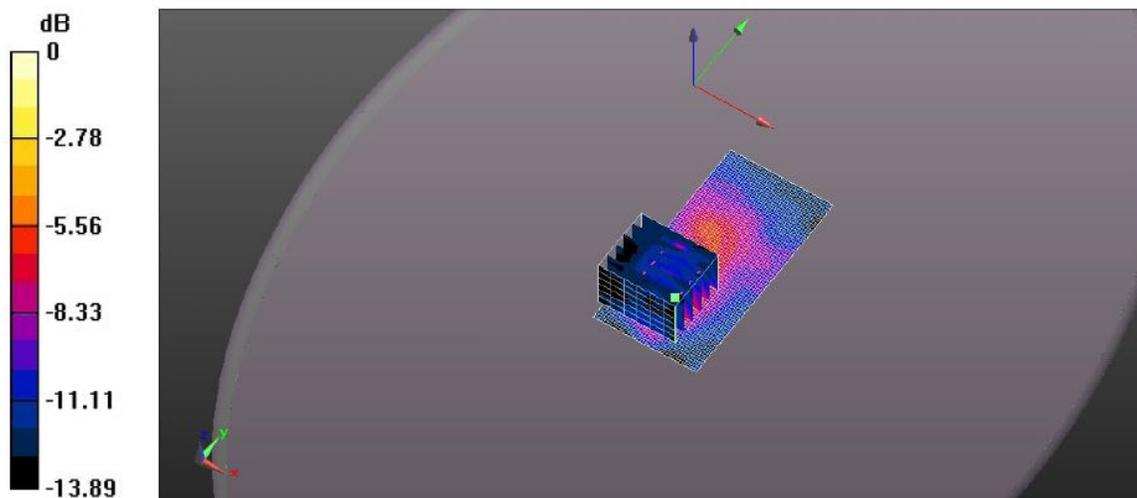

0 dB = 0.196 W/kg = -7.07 dBW/kg

**FILE NAME:** [DIGI-194Q 2440 MHZ BLE \(2MBPS\) BODY D 5MM VERTICAL BACK.DA52:0](#)

**DUT: DIGI XBPRR with BLE (2 Mbps); Type: USB Dongle**

Communication System: UID 0, CW (0); Frequency: 2440 MHz; Duty Cycle: 1:1  
Medium parameters used (interpolated):  $f = 2440$  MHz;  $\sigma = 1.903$  S/m;  $\epsilon_r = 50.536$ ;  $\rho = 1000$  kg/m<sup>3</sup> ;  
Phantom section: Flat Section ; Measurement Standard: DASYS (IEEE/IEC/ANSI C63.19-2011)

DASY Configuration:

- Probe: EX3DV4 - SN3673; ConvF(7.48, 7.48, 7.48); Calibrated: 8/30/2022;
- Sensor-Surface: 1.4mm (Mechanical Surface Detection)
- Electronics: DAE4 Sn874; Calibrated: 8/25/2022
- Phantom: ELI 4.0; Type: QD OVA 001 BB; Serial: 1057
- DASYS2 52.10.0(1446); SEMCAD X 14.6.10(7417)

**DIGI-194Q Body/Vertical Back d= 5mm/Area Scan (41x81x1):** Interpolated grid: dx=1.500 mm, dy=1.500 mm

Maximum value of SAR (interpolated) = 0.157 W/kg

**DIGI-194Q Body/Vertical Back d= 5mm/Zoom Scan (5x5x7) (7x6x7)/Cube 0:**

Measurement grid: dx=7.5mm, dy=7.5mm, dz=5mm

Reference Value = 2.881 V/m; Power Drift = -0.08 dB

Peak SAR (extrapolated) = 0.263 W/kg

**SAR(1 g) = 0.111 W/kg; SAR(10 g) = 0.054 W/kg** (SAR corrected for target medium)

Maximum value of SAR (measured) = 0.191 W/kg

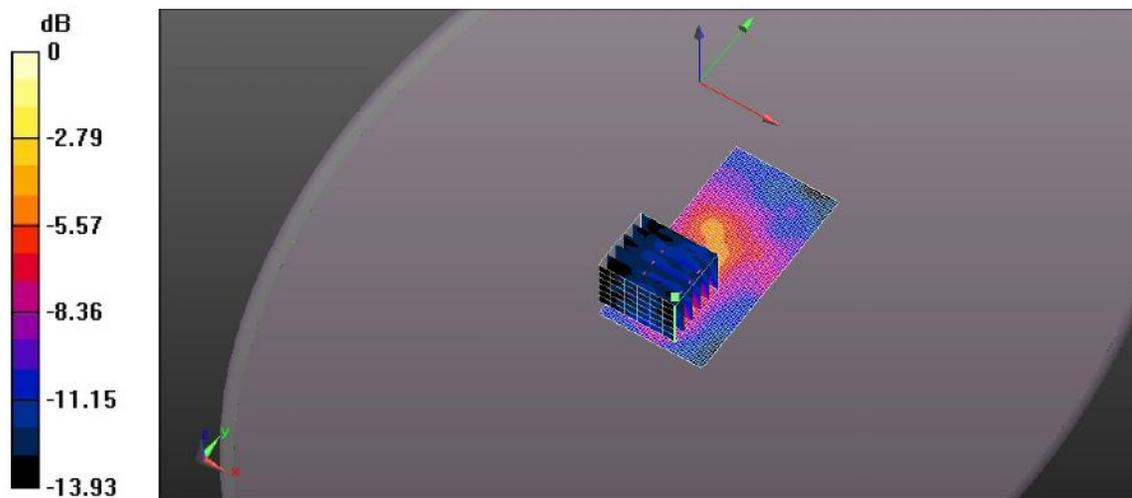

0 dB = 0.157 W/kg = -8.04 dBW/kg

**FILE NAME:** [DIGI-194Q 2478 MHZ BLE \(2MBPS\) BODY D 5MM VERTICAL BACK.DA52:0](#)

**DUT: DIGI XBPRR with BLE (2 Mbps); Type: USB Dongle**

Communication System: UID 0, CW (0); Frequency: 2478 MHz; Duty Cycle: 1:1  
Medium parameters used (interpolated):  $f = 2478$  MHz;  $\sigma = 1.952$  S/m;  $\epsilon_r = 50.376$ ;  $\rho = 1000$  kg/m<sup>3</sup> ;  
Phantom section: Flat Section ; Measurement Standard: DASYS (IEEE/IEC/ANSI C63.19-2011)

DASY Configuration:

- Probe: EX3DV4 - SN3673; ConvF(7.48, 7.48, 7.48); Calibrated: 8/30/2022;
- Sensor-Surface: 1.4mm (Mechanical Surface Detection)
- Electronics: DAE4 Sn874; Calibrated: 8/25/2022
- Phantom: ELI 4.0; Type: QD OVA 001 BB; Serial: 1057
- DASYS 52.10.0(1446); SEMCAD X 14.6.10(7417)

**DIGI-194Q Body/Vertical Back d= 5mm/Area Scan (41x81x1):** Interpolated grid: dx=1.500 mm, dy=1.500 mm

Maximum value of SAR (interpolated) = 0.0959 W/kg

**DIGI-194Q Body/Vertical Back d= 5mm/Zoom Scan (5x5x7) (7x6x7)/Cube 0:**

Measurement grid: dx=7.5mm, dy=7.5mm, dz=5mm

Reference Value = 3.036 V/m; Power Drift = 0.63 dB

Peak SAR (extrapolated) = 0.189 W/kg

**SAR(1 g) = 0.075 W/kg; SAR(10 g) = 0.039 W/kg** (SAR corrected for target medium)

Maximum value of SAR (measured) = 0.132 W/kg

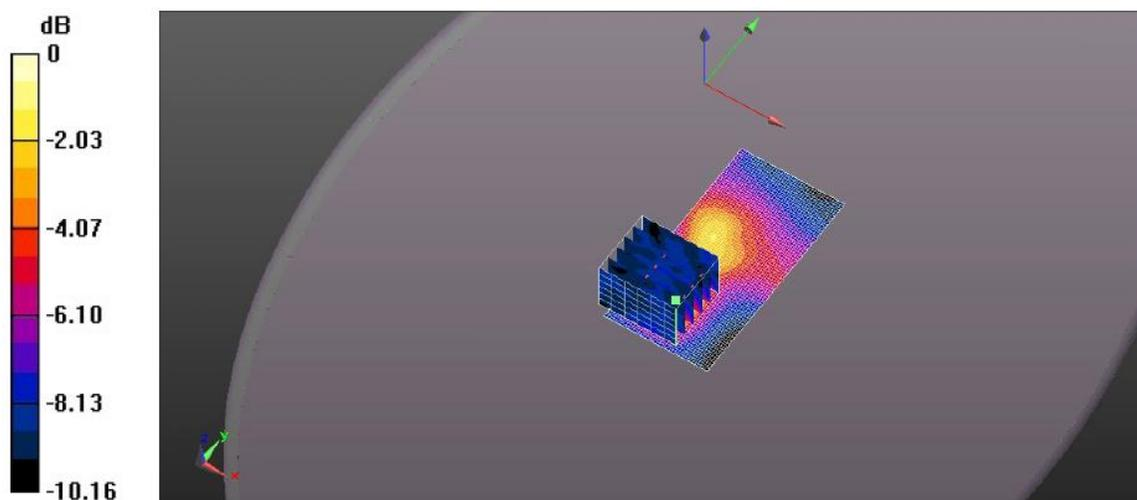

0 dB = 0.0959 W/kg = -10.18 dBW/kg



**FILE NAME:** [DIGI-194Q 2404 MHZ BLE \(2MBPS\) BODY D 5MM HORIZONTAL UP.DA52:0](#)

**DUT: DIGI XBPRR with BLE (2 Mbps); Type: USB Dongle**

Communication System: UID 0, CW (0); Frequency: 2404 MHz; Duty Cycle: 1:1  
Medium parameters used (interpolated):  $f = 2404$  MHz;  $\sigma = 1.861$  S/m;  $\epsilon_r = 50.679$ ;  $\rho = 1000$  kg/m<sup>3</sup> ;  
Phantom section: Flat Section ; Measurement Standard: DASYS (IEEE/IEC/ANSI C63.19-2011)

DASY Configuration:

- Probe: EX3DV4 - SN3673; ConvF(7.48, 7.48, 7.48); Calibrated: 8/30/2022;
- Sensor-Surface: 1.4mm (Mechanical Surface Detection)
- Electronics: DAE4 Sn874; Calibrated: 8/25/2022
- Phantom: ELI 4.0; Type: QD OVA 001 BB; Serial: 1057
- DASYS2 52.10.0(1446); SEMCAD X 14.6.10(7417)

**DIGI-194Q Body/Horizontal Up d= 5mm/Area Scan (41x81x1):** Interpolated grid: dx=1.500 mm, dy=1.500 mm

Maximum value of SAR (interpolated) = 0.169 W/kg

**DIGI-194Q Body/Horizontal Up d= 5mm/Zoom Scan (5x5x7) (7x6x7)/Cube 0:**

Measurement grid: dx=7.5mm, dy=7.5mm, dz=5mm

Reference Value = 2.564 V/m; Power Drift = 0.20 dB

Peak SAR (extrapolated) = 0.191 W/kg

**SAR(1 g) = 0.100 W/kg; SAR(10 g) = 0.054 W/kg** (SAR corrected for target medium)

Maximum value of SAR (measured) = 0.151 W/kg

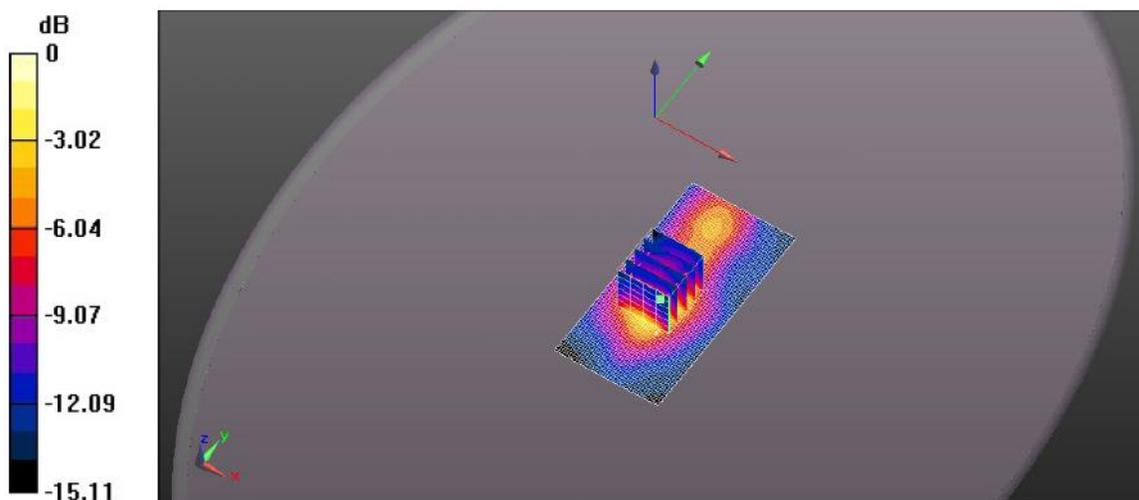

0 dB = 0.169 W/kg = -7.73 dBW/kg

**FILE NAME:** [DIGI-194Q 2440 MHZ BLE \(2MBPS\) BODY D 5MM HORIZONTAL UP.DA52:0](#)

**DUT: DIGI XBPRR with BLE (2 Mbps); Type: USB Dongle**

Communication System: UID 0, CW (0); Frequency: 2440 MHz; Duty Cycle: 1:1  
Medium parameters used (interpolated):  $f = 2440$  MHz;  $\sigma = 1.903$  S/m;  $\epsilon_r = 50.536$ ;  $\rho = 1000$  kg/m<sup>3</sup> ;  
Phantom section: Flat Section ; Measurement Standard: DASYS (IEEE/IEC/ANSI C63.19-2011)

DASY Configuration:

- Probe: EX3DV4 - SN3673; ConvF(7.48, 7.48, 7.48); Calibrated: 8/30/2022;
- Sensor-Surface: 1.4mm (Mechanical Surface Detection)
- Electronics: DAE4 Sn874; Calibrated: 8/25/2022
- Phantom: ELI 4.0; Type: QD OVA 001 BB; Serial: 1057
- DASYS 52.10.0(1446); SEMCAD X 14.6.10(7417)

**DIGI-194Q Body/Horizontal Up d= 5mm/Area Scan (41x81x1):** Interpolated grid: dx=1.500 mm, dy=1.500 mm

Maximum value of SAR (interpolated) = 0.208 W/kg

**DIGI-194Q Body/Horizontal Up d= 5mm/Zoom Scan (5x5x7) (5x5x7)/Cube 0:**

Measurement grid: dx=7.5mm, dy=7.5mm, dz=5mm  
Reference Value = 2.697 V/m; Power Drift = 1.07 dB

Peak SAR (extrapolated) = 0.276 W/kg

**SAR(1 g) = 0.140 W/kg; SAR(10 g) = 0.073 W/kg** (SAR corrected for target medium)

Maximum value of SAR (measured) = 0.219 W/kg

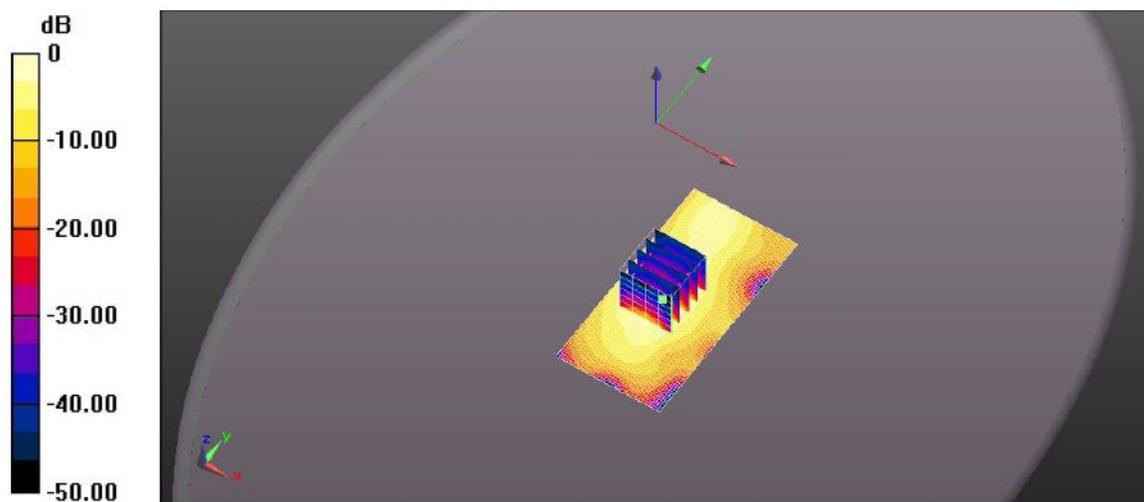

0 dB = 0.208 W/kg = -6.82 dBW/kg

**FILE NAME:** [DIGI-194Q 2478 MHZ BLE \(2MBPS\) BODY D 5MM HORIZONTAL UP.DA52:0](#)

**DUT: DIGI XBPRR with BLE (2 Mbps); Type: USB Dongle**

Communication System: UID 0, CW (0); Frequency: 2478 MHz; Duty Cycle: 1:1  
Medium parameters used (interpolated):  $f = 2478$  MHz;  $\sigma = 1.952$  S/m;  $\epsilon_r = 50.376$ ;  $\rho = 1000$  kg/m<sup>3</sup> ;  
Phantom section: Flat Section ; Measurement Standard: DASYS (IEEE/IEC/ANSI C63.19-2011)

DASY Configuration:

- Probe: EX3DV4 - SN3673; ConvF(7.48, 7.48, 7.48); Calibrated: 8/30/2022;
- Sensor-Surface: 1.4mm (Mechanical Surface Detection)
- Electronics: DAE4 Sn874; Calibrated: 8/25/2022
- Phantom: ELI 4.0; Type: QD OVA 001 BB; Serial: 1057
- DASYS2 52.10.0(1446); SEMCAD X 14.6.10(7417)

**DIGI-194Q Body/Horizontal Up d= 5mm/Area Scan (41x81x1):** Interpolated grid: dx=1.500 mm, dy=1.500 mm

Maximum value of SAR (interpolated) = 0.176 W/kg

**DIGI-194Q Body/Horizontal Up d= 5mm/Zoom Scan (5x5x7) (5x5x7)/Cube 0:**

Measurement grid: dx=7.5mm, dy=7.5mm, dz=5mm

Reference Value = 3.322 V/m; Power Drift = -1.03 dB

Peak SAR (extrapolated) = 0.223 W/kg

**SAR(1 g) = 0.114 W/kg; SAR(10 g) = 0.059 W/kg** (SAR corrected for target medium)

Maximum value of SAR (measured) = 0.179 W/kg

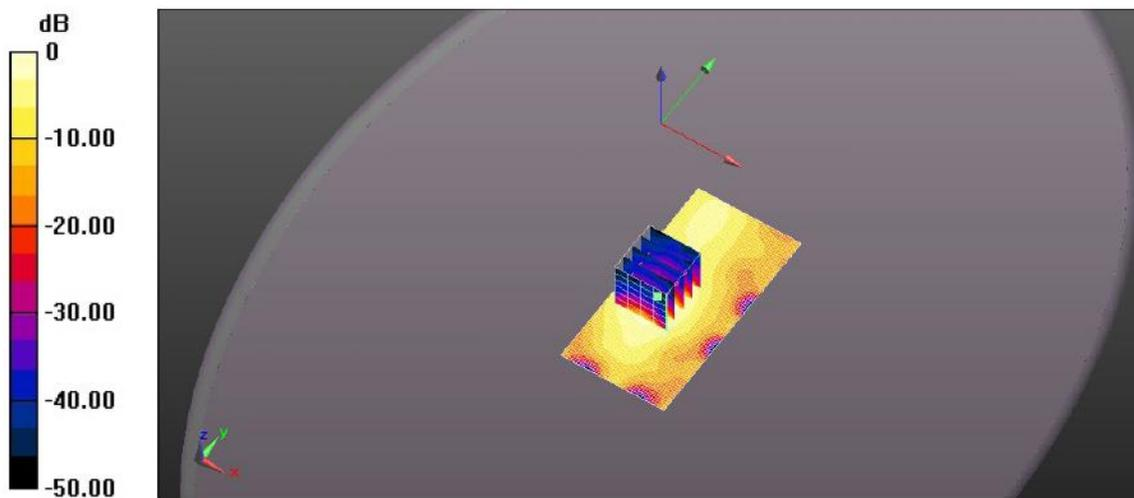

0 dB = 0.176 W/kg = -7.54 dBW/kg

**FILE NAME:** [DIGI-194Q 2404 MHZ BLE \(2MBPS\) BODY D 5MM HORIZONTAL DOWN.DA52:0](#)

**DUT: DIGI XBPRR with BLE (2 Mbps); Type: USB Dongle**

Communication System: UID 0, CW (0); Frequency: 2404 MHz; Duty Cycle: 1:1  
Medium parameters used (interpolated):  $f = 2404$  MHz;  $\sigma = 1.861$  S/m;  $\epsilon_r = 50.679$ ;  $\rho = 1000$  kg/m<sup>3</sup> ;  
Phantom section: Flat Section ; Measurement Standard: DASYS (IEEE/IEC/ANSI C63.19-2011)

DASY Configuration:

- Probe: EX3DV4 - SN3673; ConvF(7.48, 7.48, 7.48); Calibrated: 8/30/2022;
- Sensor-Surface: 1.4mm (Mechanical Surface Detection)
- Electronics: DAE4 Sn874; Calibrated: 8/25/2022
- Phantom: ELI 4.0; Type: QD OVA 001 BB; Serial: 1057
- DASYS 52.10.0(1446); SEMCAD X 14.6.10(7417)

**DIGI-194Q Body/Horizontal Down d= 5mm/Area Scan (41x81x1):** Interpolated grid:  
dx=1.500 mm, dy=1.500 mm  
Maximum value of SAR (interpolated) = 0.268 W/kg

**DIGI-194Q Body/Horizontal Down d= 5mm/Zoom Scan (5x5x7) (5x5x7)/Cube 0:**  
Measurement grid: dx=7.5mm, dy=7.5mm, dz=5mm  
Reference Value = 4.578 V/m; Power Drift = 0.21 dB  
Peak SAR (extrapolated) = 0.336 W/kg  
**SAR(1 g) = 0.150 W/kg; SAR(10 g) = 0.074 W/kg** (SAR corrected for target medium)  
Maximum value of SAR (measured) = 0.244 W/kg

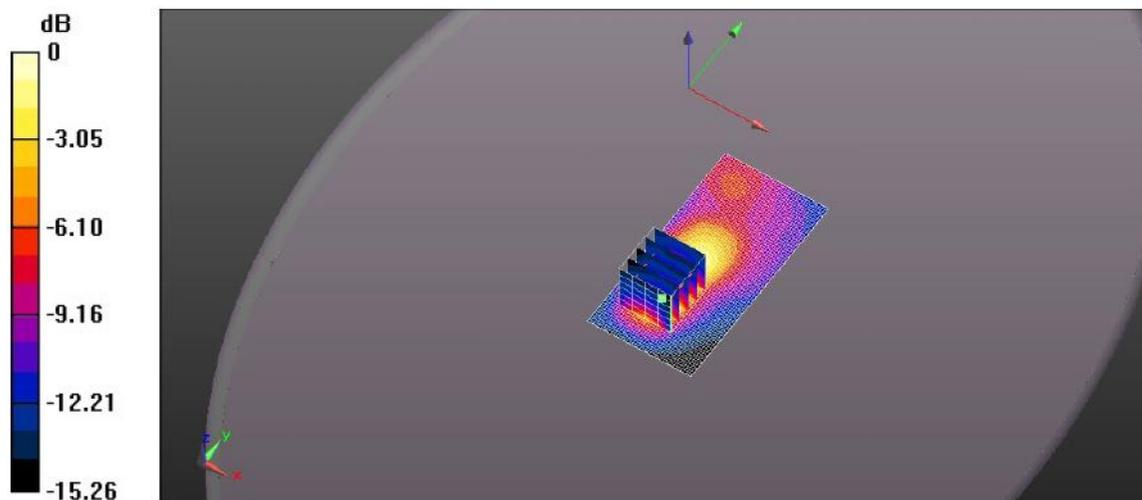

0 dB = 0.268 W/kg = -5.72 dBW/kg

**FILE NAME:** [DIGI-194Q 2440 MHZ BLE \(2MBPS\) BODY D 5MM HORIZONTAL DOWN.DA52:0](#)

**DUT: DIGI XBPRR with BLE (2 Mbps); Type: USB Dongle**

Communication System: UID 0, CW (0); Frequency: 2440 MHz; Duty Cycle: 1:1  
Medium parameters used (interpolated):  $f = 2440$  MHz;  $\sigma = 1.903$  S/m;  $\epsilon_r = 50.536$ ;  $\rho = 1000$  kg/m<sup>3</sup> ;  
Phantom section: Flat Section ; Measurement Standard: DASYS (IEEE/IEC/ANSI C63.19-2011)

DASY Configuration:

- Probe: EX3DV4 - SN3673; ConvF(7.48, 7.48, 7.48); Calibrated: 8/30/2022;
- Sensor-Surface: 1.4mm (Mechanical Surface Detection)
- Electronics: DAE4 Sn874; Calibrated: 8/25/2022
- Phantom: ELI 4.0; Type: QD OVA 001 BB; Serial: 1057
- DASYS2 52.10.0(1446); SEMCAD X 14.6.10(7417)

**DIGI-194Q Body/Horizontal Down d= 5mm/Area Scan (31x81x1):** Interpolated grid:  
dx=1.500 mm, dy=1.500 mm  
Maximum value of SAR (interpolated) = 0.320 W/kg

**DIGI-194Q Body/Horizontal Down d= 5mm/Zoom Scan (5x5x7) (5x5x7)/Cube 0:**  
Measurement grid: dx=7.5mm, dy=7.5mm, dz=5mm  
Reference Value = 2.962 V/m; Power Drift = -1.38 dB  
Peak SAR (extrapolated) = 0.457 W/kg  
**SAR(1 g) = 0.197 W/kg; SAR(10 g) = 0.094 W/kg** (SAR corrected for target medium)  
Maximum value of SAR (measured) = 0.320 W/kg

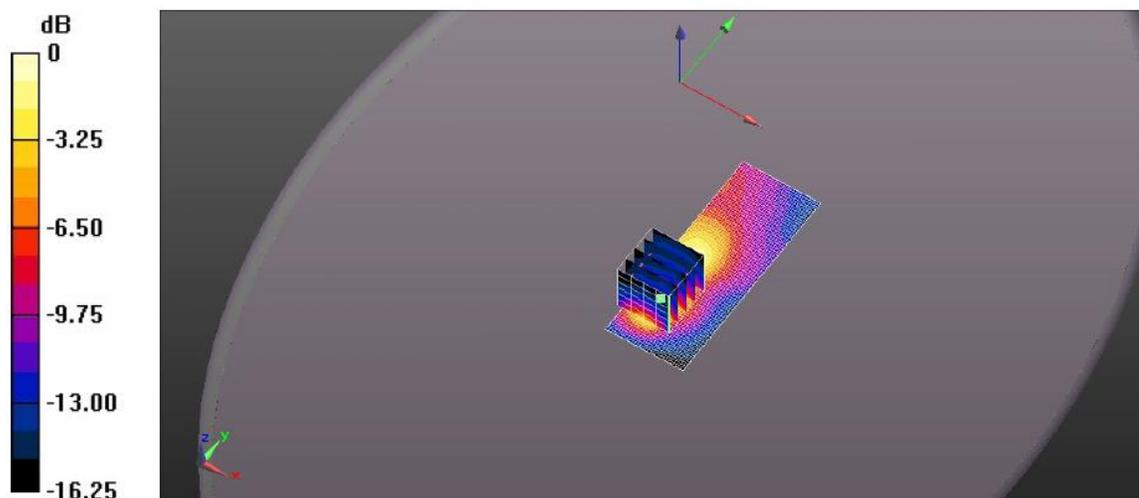

0 dB = 0.320 W/kg = -4.95 dBW/kg

**FILE NAME:** [DIGI-194Q 2478 MHZ BLE \(2MBPS\) BODY D 5MM HORIZONTAL DOWN.DA52:0](#)

**DUT: DIGI XBPRR with BLE (2 Mbps); Type: USB Dongle**

Communication System: UID 0, CW (0); Frequency: 2478 MHz; Duty Cycle: 1:1  
Medium parameters used (interpolated):  $f = 2478$  MHz;  $\sigma = 1.952$  S/m;  $\epsilon_r = 50.376$ ;  $\rho = 1000$  kg/m<sup>3</sup> ;  
Phantom section: Flat Section ; Measurement Standard: DASYS (IEEE/IEC/ANSI C63.19-2011)

DASY Configuration:

- Probe: EX3DV4 - SN3673; ConvF(7.48, 7.48, 7.48); Calibrated: 8/30/2022;
- Sensor-Surface: 1.4mm (Mechanical Surface Detection)
- Electronics: DAE4 Sn874; Calibrated: 8/25/2022
- Phantom: ELI 4.0; Type: QD OVA 001 BB; Serial: 1057
- DASYS 52.10.0(1446); SEMCAD X 14.6.10(7417)

**DIGI-194Q Body/Horizontal Up d= 5mm/Area Scan (41x81x1):** Interpolated grid: dx=1.500 mm, dy=1.500 mm

Maximum value of SAR (interpolated) = 0.242 W/kg

**DIGI-194Q Body/Horizontal Up d= 5mm/Zoom Scan (5x5x7) (5x5x7)/Cube 0:**

Measurement grid: dx=7.5mm, dy=7.5mm, dz=5mm

Reference Value = 3.649 V/m; Power Drift = -0.25 dB

Peak SAR (extrapolated) = 0.311 W/kg

**SAR(1 g) = 0.135 W/kg; SAR(10 g) = 0.066 W/kg** (SAR corrected for target medium)

Maximum value of SAR (measured) = 0.223 W/kg

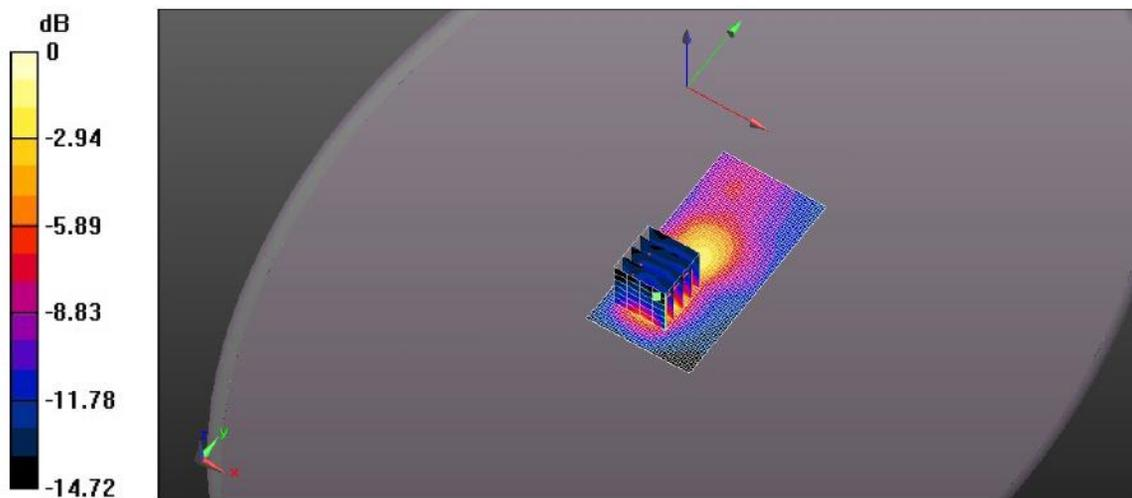

0 dB = 0.242 W/kg = -6.17 dBW/kg

**FILE NAME:** [DIGI-194Q 2404 MHZ BLE \(2MBPS\) BODY D 5MM TIP MODE.DA52:0](#)

**DUT: DIGI XBPRR with BLE (2 Mbps); Type: USB Dongle**

Communication System: UID 0, CW (0); Frequency: 2404 MHz; Duty Cycle: 1:1  
Medium parameters used (interpolated):  $f = 2404$  MHz;  $\sigma = 1.861$  S/m;  $\epsilon_r = 50.679$ ;  $\rho = 1000$  kg/m<sup>3</sup> ;  
Phantom section: Flat Section ; Measurement Standard: DASYS (IEEE/IEC/ANSI C63.19-2011)

DASY Configuration:

- Probe: EX3DV4 - SN3673; ConvF(7.48, 7.48, 7.48); Calibrated: 8/30/2022;
- Sensor-Surface: 1.4mm (Mechanical Surface Detection)
- Electronics: DAE4 Sn874; Calibrated: 8/25/2022
- Phantom: ELI 4.0; Type: QD OVA 001 BB; Serial: 1057
- DASYS 52.10.0(1446); SEMCAD X 14.6.10(7417)

**DIGI-194Q Body/Tip Mode d= 5mm/Area Scan (41x51x1):** Interpolated grid: dx=1.500 mm, dy=1.500 mm

Maximum value of SAR (interpolated) = 0.0229 W/kg

**DIGI-194Q Body/Tip Mode d= 5mm/Zoom Scan (5x5x7) (6x6x7)/Cube 0:** Measurement grid: dx=7.5mm, dy=7.5mm, dz=5mm

Reference Value = 1.125 V/m; Power Drift = -0.33 dB

Peak SAR (extrapolated) = 0.0190 W/kg

**SAR(1 g) = 0.010 W/kg; SAR(10 g) = 0.00661 W/kg** (SAR corrected for target medium)

Maximum value of SAR (measured) = 0.0146 W/kg

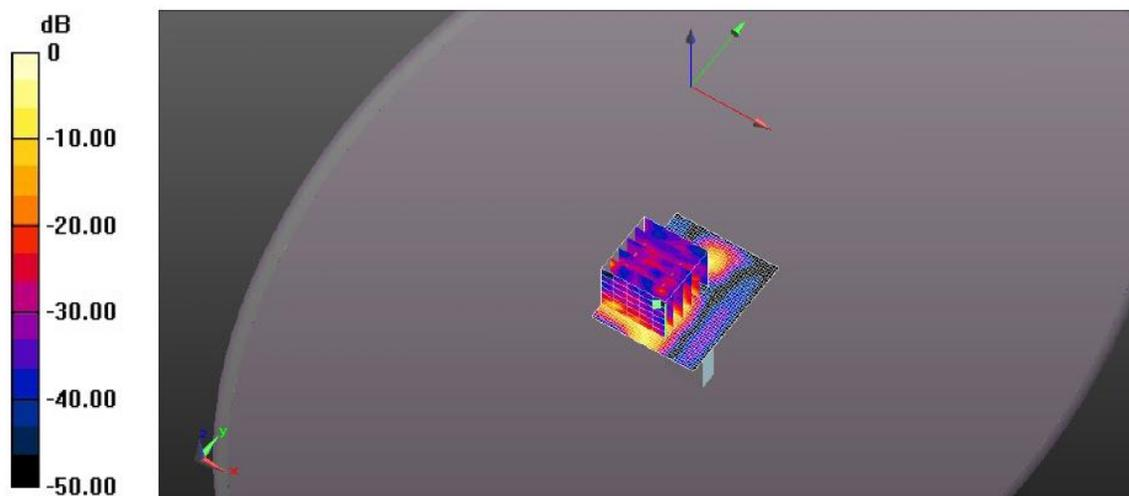

0 dB = 0.0229 W/kg = -16.40 dBW/kg

**FILE NAME:** [DIGI-194Q 2440 MHZ BLE \(2MBPS\) BODY D 5MM TIP MODE.DA52:0](#)

**DUT: DIGI XBPRR with BLE (2 Mbps); Type: USB Dongle**

Communication System: UID 0, CW (0); Frequency: 2440 MHz; Duty Cycle: 1:1  
Medium parameters used (interpolated):  $f = 2440$  MHz;  $\sigma = 1.903$  S/m;  $\epsilon_r = 50.536$ ;  $\rho = 1000$  kg/m<sup>3</sup> ;  
Phantom section: Flat Section ; Measurement Standard: DASYS (IEEE/IEC/ANSI C63.19-2011)

DASY Configuration:

- Probe: EX3DV4 - SN3673; ConvF(7.48, 7.48, 7.48); Calibrated: 8/30/2022;
- Sensor-Surface: 1.4mm (Mechanical Surface Detection)
- Electronics: DAE4 Sn874; Calibrated: 8/25/2022
- Phantom: ELI 4.0; Type: QD OVA 001 BB; Serial: 1057
- DASYS2 52.10.0(1446); SEMCAD X 14.6.10(7417)

**DIGI-194Q Body/Tip Mode d= 5mm/Area Scan (41x51x1):** Interpolated grid: dx=1.500 mm, dy=1.500 mm

Maximum value of SAR (interpolated) = 0.0229 W/kg

**DIGI-194Q Body/Tip Mode d= 5mm/Zoom Scan (5x5x7) (6x6x7)/Cube 0:** Measurement grid: dx=7.5mm, dy=7.5mm, dz=5mm

Reference Value = 1.183 V/m; Power Drift = 1.57 dB

Peak SAR (extrapolated) = 0.0240 W/kg

**SAR(1 g) = 0.013 W/kg; SAR(10 g) = 0.008 W/kg** (SAR corrected for target medium)

Maximum value of SAR (measured) = 0.0187 W/kg

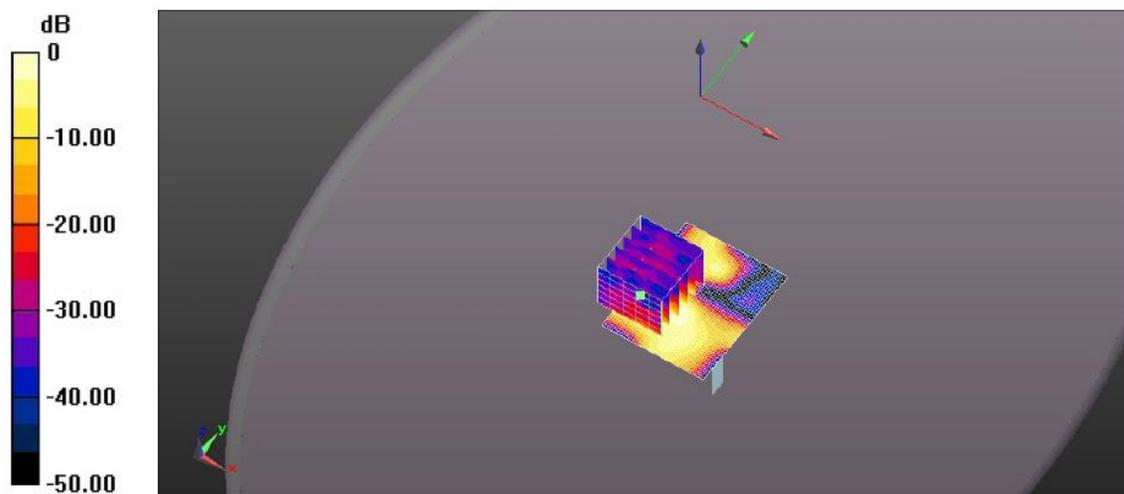

0 dB = 0.0229 W/kg = -16.40 dBW/kg



**FILE NAME:** [DIGI-194Q 2478 MHZ BLE \(2MBPS\) BODY D 5MM TIP MODE.DA52:0](#)

**DUT: DIGI XBPRR with BLE (2 Mbps); Type: USB Dongle**

Communication System: UID 0, CW (0); Frequency: 2478 MHz; Duty Cycle: 1:1  
Medium parameters used (interpolated):  $f = 2478$  MHz;  $\sigma = 1.952$  S/m;  $\epsilon_r = 50.376$ ;  $\rho = 1000$  kg/m<sup>3</sup> ;  
Phantom section: Flat Section ; Measurement Standard: DASYS (IEEE/IEC/ANSI C63.19-2011)

DASY Configuration:

- Probe: EX3DV4 - SN3673; ConvF(7.48, 7.48, 7.48); Calibrated: 8/30/2022;
- Sensor-Surface: 1.4mm (Mechanical Surface Detection)
- Electronics: DAE4 Sn874; Calibrated: 8/25/2022
- Phantom: ELI 4.0; Type: QD OVA 001 BB; Serial: 1057
- DASYS 52.10.0(1446); SEMCAD X 14.6.10(7417)

**DIGI-194Q Body/Tip Mode d= 5mm/Area Scan (51x51x1):** Interpolated grid: dx=1.500 mm, dy=1.500 mm

Maximum value of SAR (interpolated) = 0.0264 W/kg

**DIGI-194Q Body/Tip Mode d= 5mm/Zoom Scan (5x5x7) (6x6x7)/Cube 0:** Measurement grid: dx=7.5mm, dy=7.5mm, dz=5mm

Reference Value = 0.9910 V/m; Power Drift = 1.34 dB

Peak SAR (extrapolated) = 0.0210 W/kg

**SAR(1 g) = 0.011 W/kg; SAR(10 g) = 0.0067 W/kg** (SAR corrected for target medium)

Maximum value of SAR (measured) = 0.0149 W/kg

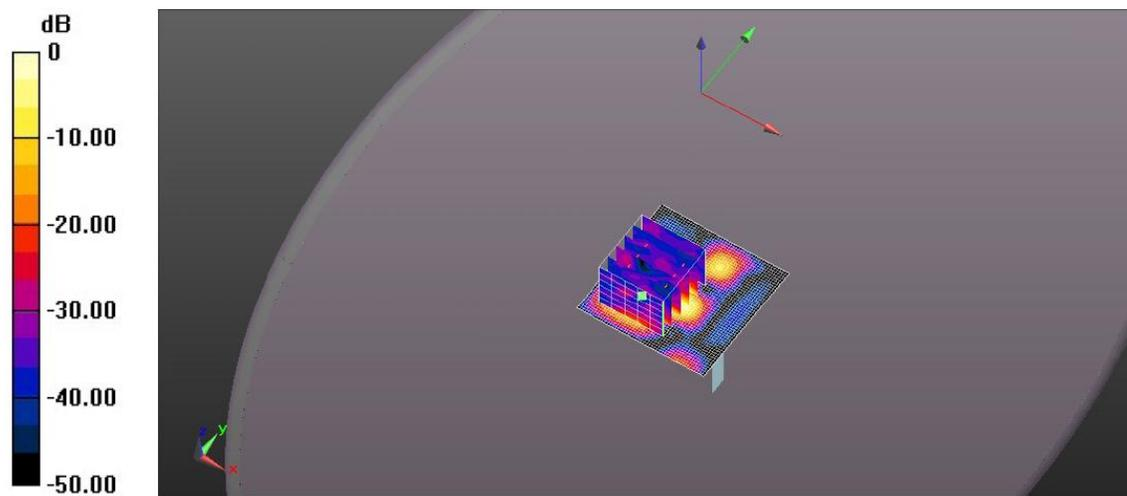

0 dB = 0.0264 W/kg = -15.78 dBW/kg