

ENGINEERING TEST REPORT

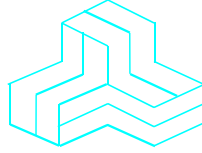

XBee XR 900
Model: XB9XR
FCC ID: MCQ-XB9XR

Applicant:

Digi International Inc
9350 Excelsior Blvd. Suite 700
Hopkins, MN 55343

In Accordance With

Federal Communications Commission (FCC)
Part 15, Subpart C, Section 15.247 Frequency Hopping Spread Spectrum (FHSS)

UltraTech's File No.: 24MCRS201_FCC15C247

This Test report is Issued under the Authority of
Tri M. Luu
Vice President of Engineering
UltraTech Group of Labs

Date: March 27, 2024

Report Prepared by: Dan Huynh

Tested by: Angus Au

Issued Date: March 27, 2024

Test Dates:
December 6 - 21, 2023
January 2- March 21, 2024

- *The results in this Test Report apply only to the sample(s) tested, and the sample tested is randomly selected.*
- *This report must not be used by the client to claim product endorsement by any agency of the US Government.*
- *This test report shall not be reproduced, except in full, without a written approval from UltraTech*

UltraTech

3000 Bristol Circle, Oakville, Ontario, Canada, L6H 6G4
Tel.: (905) 829-1570 Fax.: (905) 829-8050
Website: www.ultratech-labs.com, Email: vic@ultratech-labs.com, Email: tri@ultratech-labs.com



0685



APEC TEL CA0001



1309



CA 0001/2049



AT-1945



SL2-IN-E-1119R



Korea KCC-RRR

CA0001

TABLE OF CONTENTS

EXHIBIT 1. INTRODUCTION..... 1

1.1. SCOPE 1

1.2. RELATED SUBMITTAL(S)/GRANT(S) 1

1.3. NORMATIVE REFERENCES 1

EXHIBIT 2. PERFORMANCE ASSESSMENT 2

2.1. EQUIPMENT UNDER TEST (EUT) INFORMATION 2

2.2. EUT’S TECHNICAL SPECIFICATIONS..... 3

2.3. ASSOCIATED ANTENNA DESCRIPTIONS 3

2.4. LIST OF EUT’S PORTS..... 3

2.5. ANCILLARY EQUIPMENT 4

EXHIBIT 3. EUT OPERATING CONDITIONS AND CONFIGURATIONS DURING TESTS 5

3.1. CLIMATE TEST CONDITIONS 5

3.2. OPERATIONAL TEST CONDITIONS & ARRANGEMENT FOR TESTS..... 5

EXHIBIT 4. SUMMARY OF TEST RESULTS..... 6

4.1. LOCATION OF TESTS 6

4.2. APPLICABILITY & SUMMARY OF EMC EMISSION TEST RESULTS 6

4.3. MODIFICATIONS INCORPORATED IN THE EUT FOR COMPLIANCE PURPOSES 6

EXHIBIT 5. TEST DATA..... 7

5.1. POWER LINE CONDUCTED EMISSIONS [§15.207(a)]..... 7

5.2. COMPLIANCE WITH FCC PART 15 – GENERAL TECHNICAL REQUIREMENTS 28

5.3. PROVISIONS FOR FREQUENCY HOPPING SYSTEMS [§ 15.247(a)(1)]..... 30

5.4. PEAK CONDUCTED OUTPUT POWER [§ 15.247(b)(2)]..... 50

5.5. TRANSMITTER SPURIOUS RADIATED EMISSIONS AT 3 METERS [§§ 15.247(d), 15.209 & 15.205] 79

5.6. RF EXPOSURE REQUIRMENTS [§§ 15.247(i), 1.1310 & 2.1091]..... 82

EXHIBIT 6. TEST EQUIPMENT LIST 84

EXHIBIT 7. MEASUREMENT UNCERTAINTY 85

APPENDIX A. XB-9XR-DMUM-001 TRANSMITTER SPURIOUS RADIATED EMISSIONS AT 3M

APPENDIX B. XB-9XR-DMUS-001 TRANSMITTER SPURIOUS RADIATED EMISSIONS AT 3M

APPENDIX C. XB-9XR-DMUT-001 TRANSMITTER SPURIOUS RADIATED EMISSIONS AT 3M

APPENDIX D. XB-9XR-DMST-001 TRANSMITTER SPURIOUS RADIATED EMISSIONS AT 3M

APPENDIX E. XB-9XR-DMCS-001 TRANSMITTER SPURIOUS RADIATED EMISSIONS AT 3M

EXHIBIT 1. INTRODUCTION

1.1. SCOPE

Reference:	FCC Part 15, Subpart C, Section 15.247
Title:	Code of Federal Regulations (CFR), Title 47 – Telecommunication, Part 15 – Radio Frequency Devices
Purpose of Test:	Equipment Certification for Part 15C Spread Spectrum Transmitter
Test Procedures:	<ul style="list-style-type: none">▪ ANSI C63.4▪ ANSI C63.10
Environmental Classification:	[x] Commercial, industrial or business environment [x] Residential environment

1.2. RELATED SUBMITTAL(S)/GRANT(S)

None.

1.3. NORMATIVE REFERENCES

Publication	Year	Title
47 CFR Parts 0-19	2024	Code of Federal Regulations (CFR), Title 47 – Telecommunication
ANSI C63.4	2014	American National Standard for Methods of Measurement of Radio-Noise Emissions from Low-Voltage Electrical and Electronic Equipment in the Range of 9 KHz to 40 GHz
ANSI C63.10	2020	American National Standard of Procedures for Compliance Testing of Unlicensed Wireless Devices

EXHIBIT 2. PERFORMANCE ASSESSMENT

Applicant	
Name:	Digi International Inc.
Address:	9350 Excelsior Blvd. Suite 700 Hopkins, MN 55343 USA

Manufacturer	
Name:	Digi International Inc.
Address:	9350 Excelsior Blvd. Suite 700 Hopkins, MN 55343 USA

2.1. EQUIPMENT UNDER TEST (EUT) INFORMATION

The following information (with the exception of the Date of Receipt) has been supplied by the applicant.

Brand Name:	Digi International Inc.
Product Name:	XBee XR 900
Model Name or Number:	XB9XR
P/N*:	XB-9XR-DMUM-001, XB-9XR-DMUS-001, XB-9XR-DMUT-001, XB-9XR-DMST-001 and XB-9XR-DMCS-001
Serial Number:	Test Samples
Type of Equipment:	Spread Spectrum Transmitter
Input Power Supply Type:	External DC Power Supply
Primary User Functions of EUT:	Digital Communications

*The XBee XR 900 series consist of five product variants with different antenna connector types or integral antenna, form factor and carrier board/mounting interface. Refer to manufacturer’s product description and photos for detail. In regards to testing, XB-9XR-DMUM-001 version was selected as the worst-case, complete transmitter tests were performed on this unit, all conducted measurement test results for this test sample is representative of all the other product variants. Additionally, conducted power (product variants with antenna connector) and radiated emissions were performed on all the other product variants to ensure compliance as documented in this report.

2.2. EUT’S TECHNICAL SPECIFICATIONS

Transmitter	
Equipment Type:	<ul style="list-style-type: none"> ▪ Mobile ▪ Base Station (fixed use)
Intended Operating Environment:	Residential environment Commercial, industrial or business environment
Power Supply Requirement:	2.1 to 3.6 VDC (3.3 VDC nominal)
RF Output Power Rating:	Max: 18.91 dBm, 0.07780 W Min: 0.07 dBm, 0.00102 W
Operating Frequency Range:	902.5 – 927.0 MHz (for 10 kbps and 110 kbps data rates) 902.75 – 927.25 MHz (for 250 kbps data rate)
RF Output Impedance:	50 Ω
Duty Cycle:	Continuous
Modulation Type:	GFSK
Antenna Connector Type:	U.FL / Integral / RPSMA

2.3. ASSOCIATED ANTENNA DESCRIPTIONS

Antenna Type	Maximum Gain (dBi)
Flat Antenna	2
Dipole Antenna	2.96
Omni Directional Antenna	8.0
Yagi Antenna	15.1
Flex Antenna	1
Phantom (Dome) Antenna	3
Ceramic Chip Antenna	0.8

2.4. LIST OF EUT’S PORTS

Port Number	EUT’s Port Description	Number of Identical Ports	Connector Type	Cable Type (Shielded/Non-shielded)
1	RF Port	1	U.FL / RPSMA	Shielded
2	UART, GPIO	1	Custom 34 pin header	Direct connection

2.5. ANCILLARY EQUIPMENT

The EUT was tested while connected to the following representative configuration of ancillary equipment necessary to exercise the ports during tests:

Ancillary Equipment # 1	
Description:	Test Jig for XB-9XR-DMUM-001
Brand name:	Digi International Inc
Model Name or Number:	XBIB-C-MMT
Connected to EUT's Port:	Custom XBee MMT interface

Ancillary Equipment # 2	
Description:	Test Jig for XB-9XR-DMUS-001
Brand name:	Digi International Inc
Model Name or Number:	XBIB-C-SMT
Connected to EUT's Port:	Custom XBee SMT interface

Ancillary Equipment # 3	
Description:	Test Jig for XB-9XR-DMUT-001 and XB-9XR-DMST-001
Brand name:	Digi International Inc
Model Name or Number:	XBIB-CU-TH
Connected to EUT's Port:	Custom XBee TH interface

Ancillary Equipment # 4	
Description:	Test Jig for XB-9XR-DMCS-001
Brand name:	Digi International Inc
Model Name or Number:	XBIB-C-SMT
Connected to EUT's Port:	Custom XBee SMT interface, to use the Chip antenna

Ancillary Equipment # 5	
Description:	Laptop
Brand name:	HP
Model Name or Number:	EliteBook 820
Connected to EUT's Port:	Test Jig of the EUT

EXHIBIT 3. EUT OPERATING CONDITIONS AND CONFIGURATIONS DURING TESTS

3.1. CLIMATE TEST CONDITIONS

The climate conditions of the test environment are as follows:

Temperature:	21 to 23 °C
Humidity:	45 to 58%
Pressure:	102 kPa
Power Input Source:	3.3 VDC via test jig

3.2. OPERATIONAL TEST CONDITIONS & ARRANGEMENT FOR TESTS

Operating Modes:	<ul style="list-style-type: none"> Each of lowest, middle and highest channel frequencies transmits continuously for emissions measurements. The EUT operates in normal Frequency Hopping mode for tests required hopping mode to be enabled.
Special Test Software:	Test software (Version 6.5.13) provided by the Applicant is installed to allow the EUT to operate in hopping mode or at each channel frequency continuously and in the range of typical modes of operation.
Special Hardware Used:	Test Jigs
Transmitter Test Antenna:	The EUT is tested with the antenna fitted in a manner typical of normal intended use as non-integral/integral antenna equipment as described with the test results.

Transmitter Test Signals	
Frequency Band(s):	902.5 - 927 MHz 902.75 - 927.25 MHz
Frequency(ies) Tested: (Near lowest, near middle & near highest frequencies in the frequency range of operation.)	For 10 kbps and 110 kbps: 902.5 MHz, 915 MHz, 927 MHz For 250 kbps: 902.75 MHz, 915.25 MHz, 927.25 MHz
RF Power Output: (measured maximum output power at antenna terminals)	For 902.5 - 927 MHz Band: 18.91 dBm (0.07780 W) For 902.75 - 927.25 MHz Band: 18.91dBm (0.07780 W)
Normal Test Modulation:	GFSK
Modulating Signal Source:	Internal

EXHIBIT 4. SUMMARY OF TEST RESULTS

4.1. LOCATION OF TESTS

All of the measurements described in this report were performed at Ultratech Group of Labs located in the city of Oakville, Province of Ontario, Canada.

- AC Power Line Conducted Emissions were performed in UltraTech's shielded room, 24'(L) by 16'(W) by 8'(H).
- Radiated Emissions were performed at the Ultratech's 3-10 TDK Semi-Anechoic Chamber situated in the Town of Oakville, province of Ontario. This test site been calibrated in accordance with ANSI C63.4, and found to be in compliance with the requirements of Sec. 2.948 of the FCC Rules. The descriptions and site measurement data of the Oakville 3-10 TDK Semi-Anechoic Chamber has been filed with ANAB File No.: AT-1945.

4.2. APPLICABILITY & SUMMARY OF EMC EMISSION TEST RESULTS

FCC Section(s)	Test Requirements	Compliance (Yes/No)
15.203	Antenna requirements	Yes
15.207(a)	AC Power Line Conducted Emissions	Yes
15.247(a)	Provisions for Frequency Hopping Systems	Yes
15.247(b)(2)	Maximum Peak Conducted Output Power	Yes
15.247(d), 15.209 & 15.205	Transmitter Spurious Radiated Emissions	Yes
15.247(i), 1.1307, 1.1310, 2.1091	RF Exposure	Yes

4.3. MODIFICATIONS INCORPORATED IN THE EUT FOR COMPLIANCE PURPOSES

None.

EXHIBIT 5. TEST DATA

5.1. POWER LINE CONDUCTED EMISSIONS [§15.207(a)]

5.1.1. Limit(s)

The equipment shall meet the limits of the following table:

Frequency of emission (MHz)	Conducted Limits (dB μ V)	
	Quasi-peak	Average
0.15–0.5	66 to 56*	56 to 46*
0.5–5	56	46
5–30	60	50

*Decreases linearly with the logarithm of the frequency

5.1.2. Method of Measurements

ANSI C63.4

5.1.3. Test Arrangement

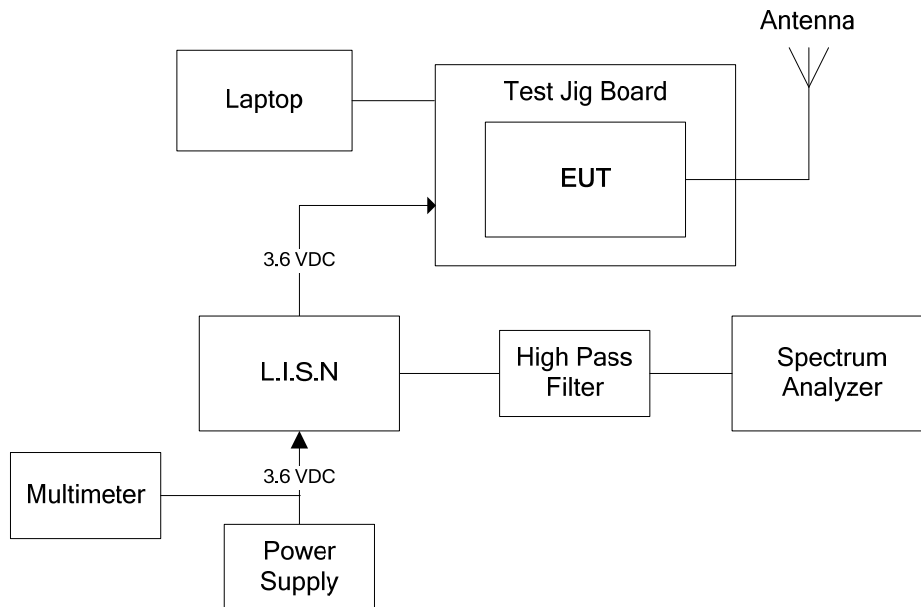

5.1.4. Test Data

Plot 5.1.4.1. XB-9XR-DMUM-001 Power Line Conducted Emissions (Tx Mode)
 Line Voltage: 3.6 VDC; Line Tested: Positive

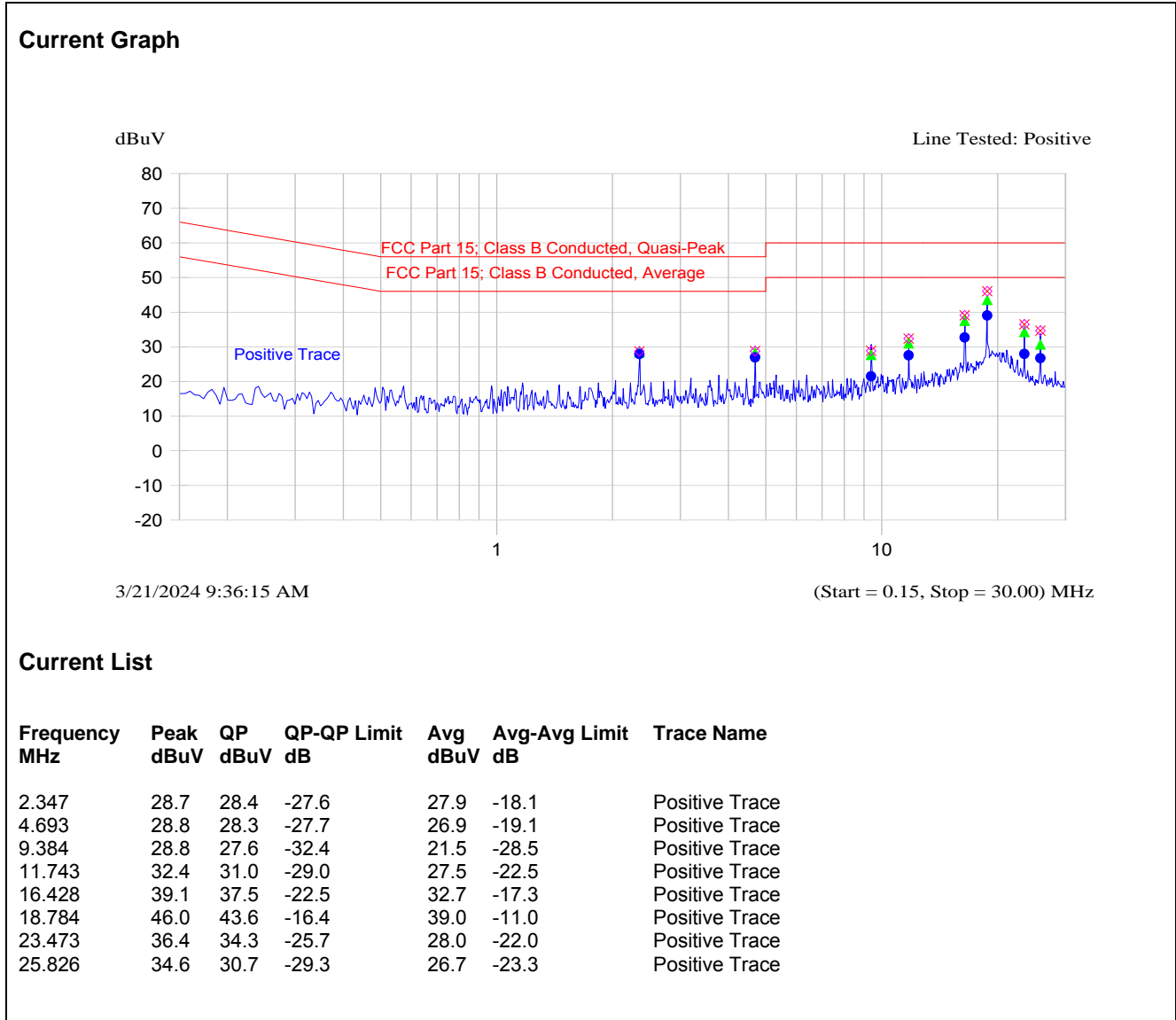

Plot 5.1.4.2. XB-9XR-DMUM-001 Power Line Conducted Emissions (Tx Mode)
 Line Voltage: 3.6 VDC; Line Tested: Negative

Current Graph

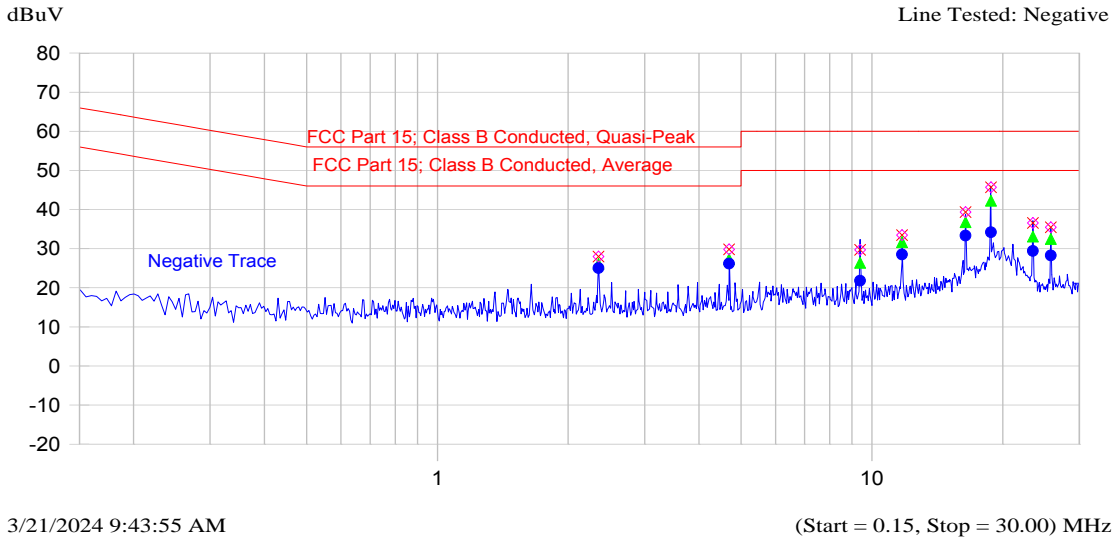

Current List

Frequency MHz	Peak dBuV	QP dBuV	QP-QP Limit dB	Avg dBuV	Avg-Avg Limit dB	Trace Name
2.348	28.0	26.1	-29.9	25.0	-21.0	Negative Trace
4.693	29.8	27.3	-28.7	26.2	-19.8	Negative Trace
9.392	29.7	26.4	-33.6	21.8	-28.2	Negative Trace
11.734	33.4	31.7	-28.3	28.5	-21.5	Negative Trace
16.424	39.3	36.8	-23.2	33.3	-16.7	Negative Trace
18.782	45.7	42.2	-17.8	34.2	-15.8	Negative Trace
23.471	36.5	33.1	-26.9	29.4	-20.6	Negative Trace
25.809	35.4	32.5	-27.5	28.3	-21.7	Negative Trace

Plot 5.1.4.3. XB-9XR-DMUM-001 Power Line Conducted Emissions (Rx Mode)
 Line Voltage: 3.6 VDC; Line Tested: Positive

Current Graph

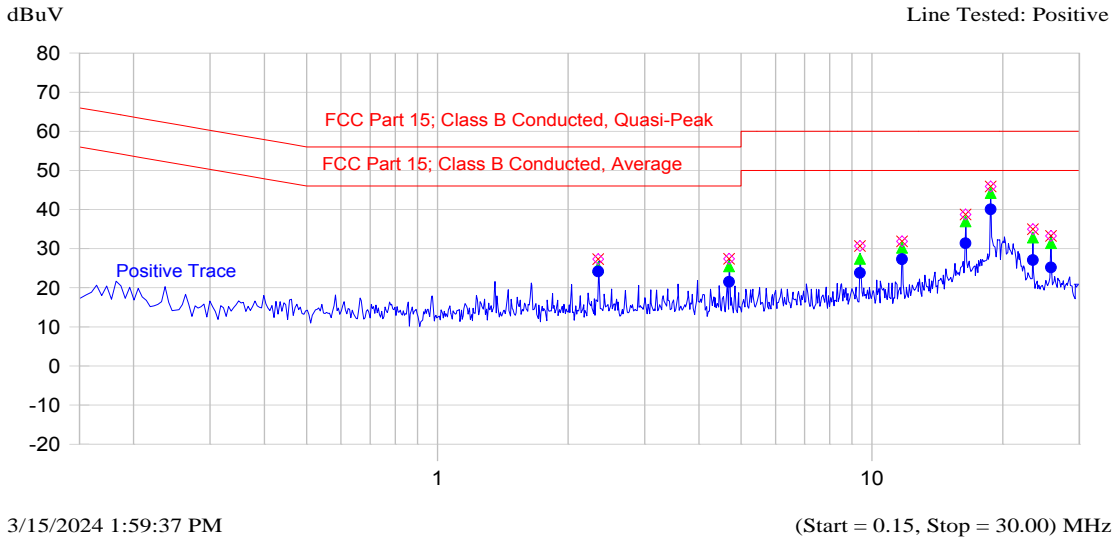

Current List

Frequency MHz	Peak dBuV	QP dBuV	QP-QP Limit dB	Avg dBuV	Avg-Avg Limit dB	Trace Name
2.346	27.3	25.2	-30.8	24.1	-21.9	Positive Trace
4.691	27.4	25.5	-30.5	21.5	-24.5	Positive Trace
9.383	30.7	27.4	-32.6	23.8	-26.2	Positive Trace
11.736	31.9	30.2	-29.8	27.3	-22.7	Positive Trace
16.425	38.7	37.0	-23.0	31.4	-18.6	Positive Trace
18.772	45.9	44.2	-15.8	40.1	-9.9	Positive Trace
23.471	35.0	32.8	-27.2	27.1	-22.9	Positive Trace
25.820	33.3	31.4	-28.6	25.2	-24.8	Positive Trace

Plot 5.1.4.4. XB-9XR-DMUM-001 Power Line Conducted Emissions (Rx Mode)
 Line Voltage: 3.6 VDC; Line Tested: Negative

Current Graph

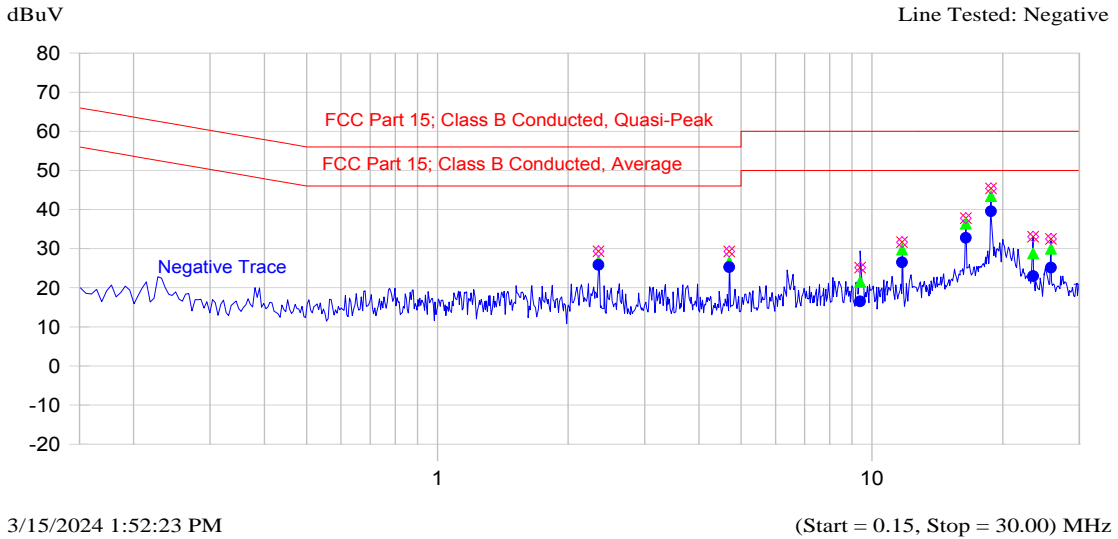

Current List

Frequency MHz	Peak dBuV	QP dBuV	QP-QP Limit dB	Avg dBuV	Avg-Avg Limit dB	Trace Name
2.347	29.3	26.8	-29.2	25.8	-20.2	Negative Trace
4.696	29.3	26.6	-29.4	25.3	-20.7	Negative Trace
9.399	25.1	21.5	-38.5	16.5	-33.5	Negative Trace
11.738	31.6	29.8	-30.2	26.5	-23.5	Negative Trace
16.437	37.8	36.4	-23.6	32.8	-17.2	Negative Trace
18.782	45.4	43.4	-16.6	39.5	-10.5	Negative Trace
23.491	33.0	28.8	-31.2	23.0	-27.0	Negative Trace
25.820	32.5	30.0	-30.0	25.1	-24.9	Negative Trace

Plot 5.1.4.5. XB-9XR-DMUS-001 Power Line Conducted Emissions (Tx Mode)
 Line Voltage: 3.6 VDC; Line Tested: Positive

Current Graph

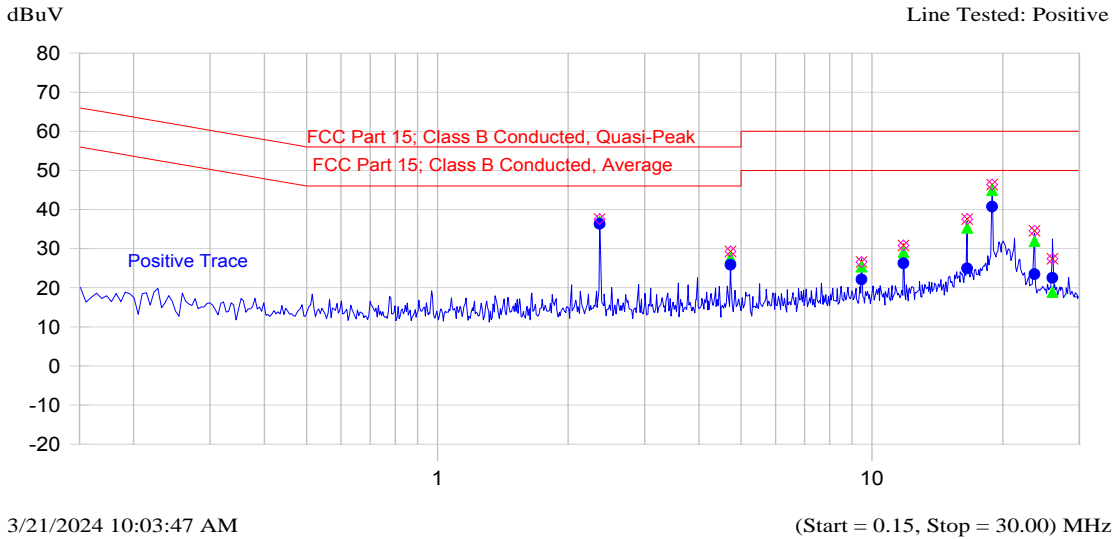

Current List

Frequency MHz	Peak dBuV	QP dBuV	QP-QP Limit dB	Avg dBuV	Avg-Avg Limit dB	Trace Name
2.363	37.5	37.0	-19.0	36.4	-9.6	Positive Trace
4.726	29.3	27.7	-28.3	25.9	-20.1	Positive Trace
9.456	26.6	25.4	-34.6	22.1	-27.9	Positive Trace
11.820	30.8	29.1	-30.9	26.2	-23.8	Positive Trace
16.556	37.5	35.4	-24.6	24.9	-25.1	Positive Trace
18.912	46.4	44.9	-15.1	40.7	-9.3	Positive Trace
23.651	34.5	31.9	-28.1	23.5	-26.5	Positive Trace
26.015	27.4	18.9	-41.1	22.5	-27.5	Positive Trace

Plot 5.1.4.6. XB-9XR-DMUS-001 Power Line Conducted Emissions (Tx Mode)
 Line Voltage: 3.6 VDC; Line Tested: Negative

Current Graph

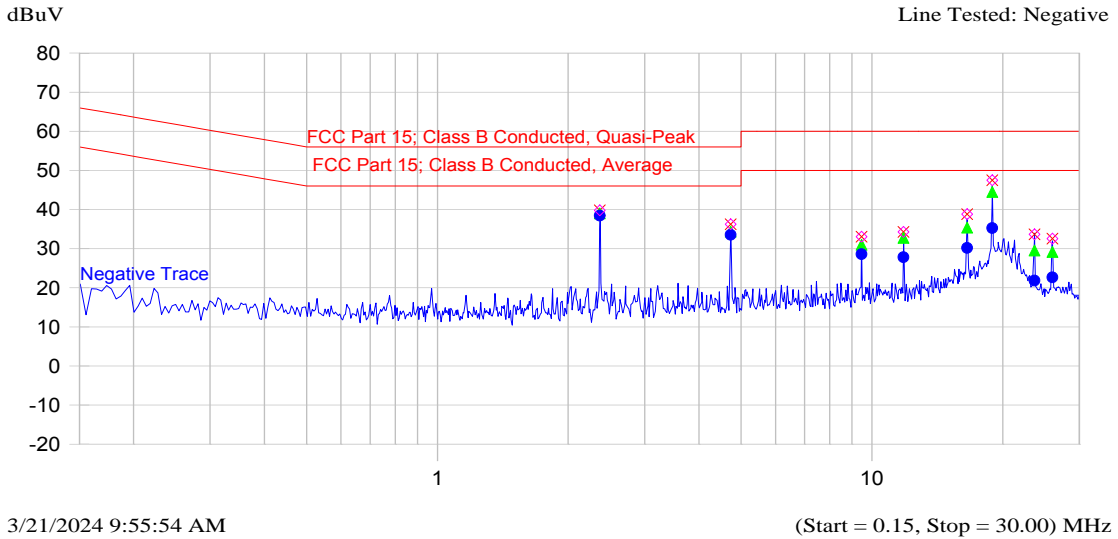

Current List

Frequency MHz	Peak dBuV	QP dBuV	QP-QP Limit dB	Avg dBuV	Avg-Avg Limit dB	Trace Name
2.366	39.8	39.0	-17.0	38.4	-7.6	Negative Trace
4.729	36.3	34.4	-21.6	33.5	-12.5	Negative Trace
9.462	33.0	31.0	-29.0	28.6	-21.4	Negative Trace
11.822	34.2	32.7	-27.3	27.8	-22.2	Negative Trace
16.558	38.8	35.4	-24.6	30.1	-19.9	Negative Trace
18.922	47.5	44.5	-15.5	35.3	-14.7	Negative Trace
23.655	33.6	29.5	-30.5	21.8	-28.2	Negative Trace
26.017	32.5	29.2	-30.8	22.7	-27.3	Negative Trace

Plot 5.1.4.7. XB-9XR-DMUS-001 Power Line Conducted Emissions (Rx Mode)
 Line Voltage: 3.6 VDC; Line Tested: Positive

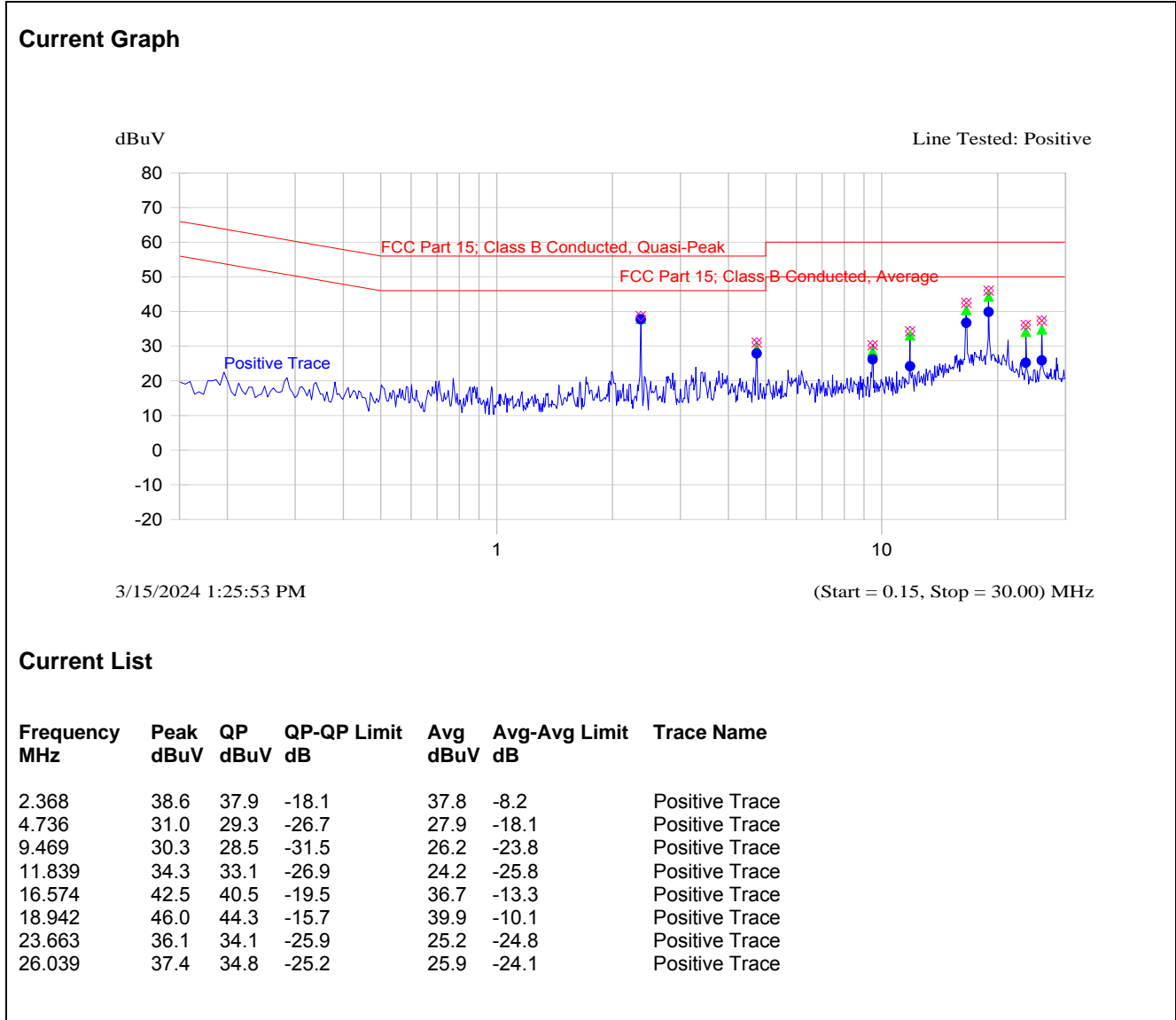

Plot 5.1.4.8. XB-9XR-DMUS-001 Power Line Conducted Emissions (Rx Mode)
 Line Voltage: 3.6 VDC; Line Tested: Negative

Current Graph

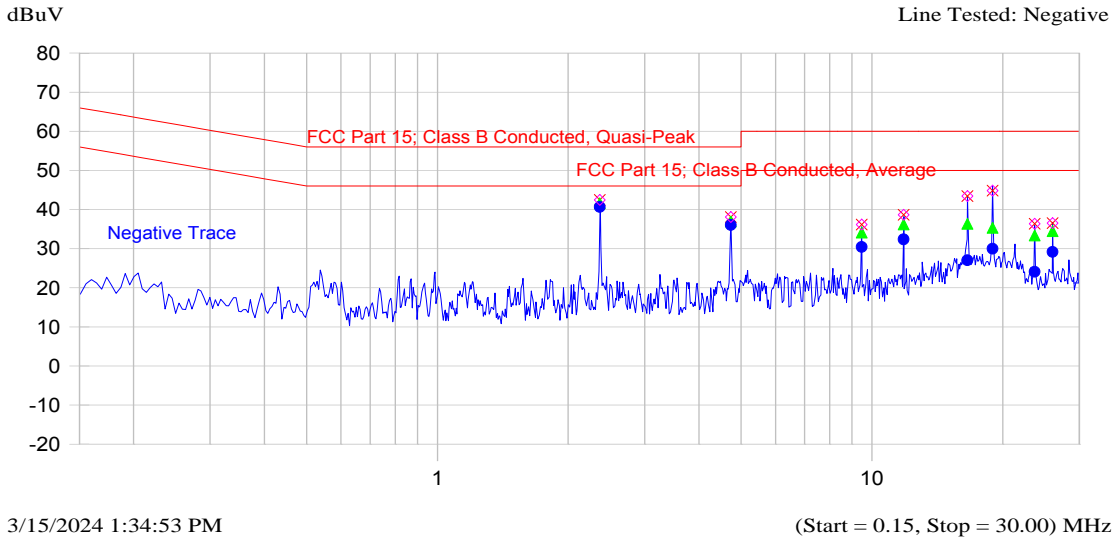

Current List

Frequency MHz	Peak dBuV	QP dBuV	QP-QP Limit dB	Avg dBuV	Avg-Avg Limit dB	Trace Name
2.365	42.4	41.6	-14.4	40.6	-5.4	Negative Trace
4.736	38.1	36.9	-19.1	36.0	-10.0	Negative Trace
9.473	36.2	34.1	-25.9	30.4	-19.6	Negative Trace
11.835	38.6	36.2	-23.8	32.4	-17.6	Negative Trace
16.591	43.4	36.3	-23.7	27.0	-23.0	Negative Trace
18.956	44.8	35.3	-24.7	30.0	-20.0	Negative Trace
23.680	36.4	33.4	-26.6	24.1	-25.9	Negative Trace
26.047	36.5	34.5	-25.5	29.1	-20.9	Negative Trace

Plot 5.1.4.9. XB-9XR-DMUT-001 Power Line Conducted Emissions (Tx Mode)
 Line Voltage: 3.6 VDC; Line Tested: Positive

Current Graph

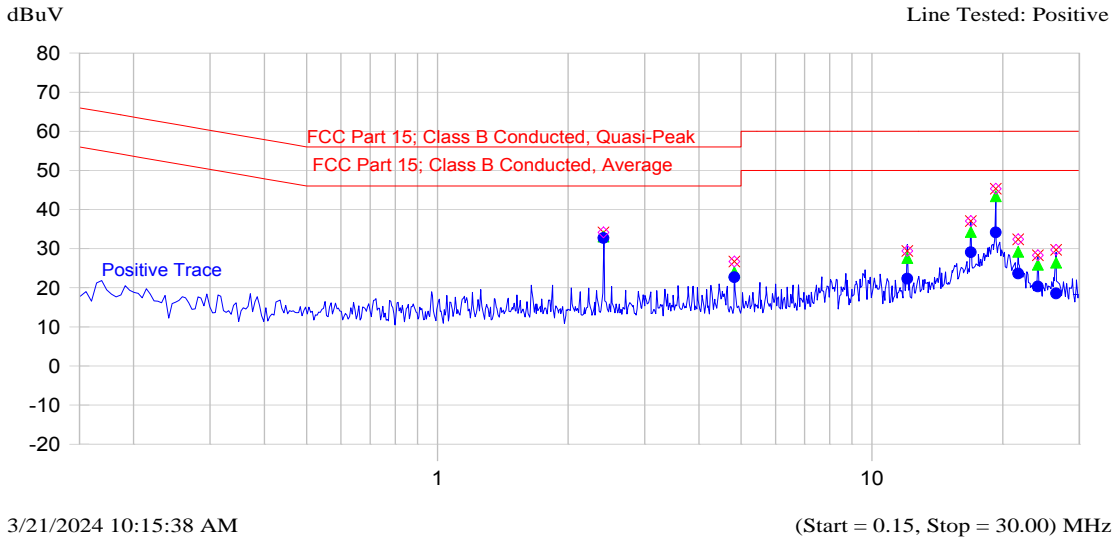

Current List

Frequency MHz	Peak dBuV	QP dBuV	QP-QP Limit dB	Avg dBuV	Avg-Avg Limit dB	Trace Name
2.411	34.1	33.1	-22.9	32.7	-13.3	Positive Trace
4.820	26.7	24.0	-32.0	22.7	-23.3	Positive Trace
12.055	29.4	27.6	-32.4	22.3	-27.7	Positive Trace
16.880	37.0	34.2	-25.8	29.1	-20.9	Positive Trace
19.278	45.3	43.4	-16.6	34.1	-15.9	Positive Trace
21.696	32.4	29.2	-30.8	23.6	-26.4	Positive Trace
24.101	28.3	25.9	-34.1	20.3	-29.7	Positive Trace
26.526	29.7	26.4	-33.6	18.5	-31.5	Positive Trace

Plot 5.1.4.10. XB-9XR-DMUT-001 Power Line Conducted Emissions (Tx Mode)
 Line Voltage: 3.6 VDC; Line Tested: Negative

Current Graph

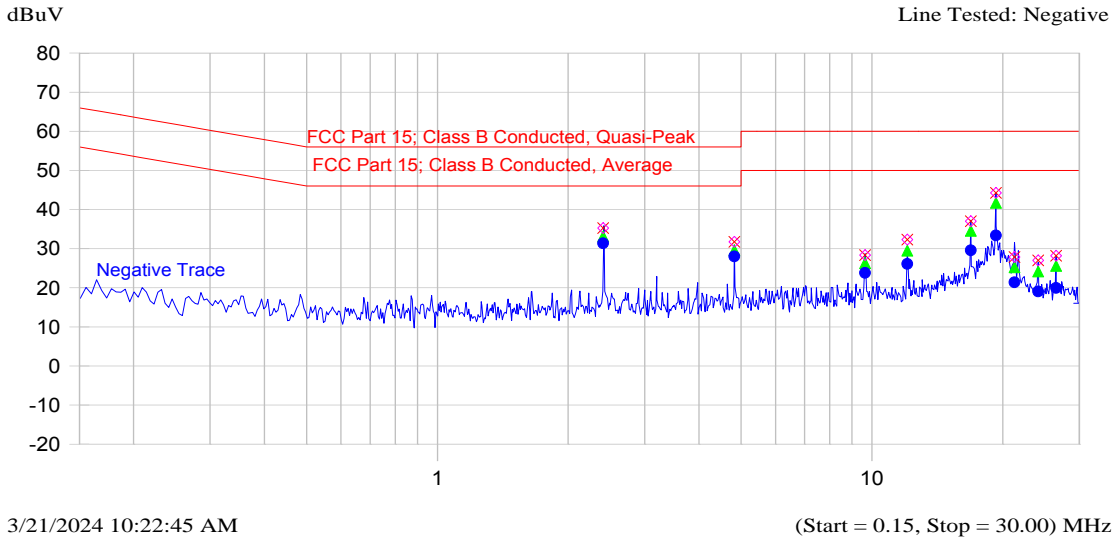

Current List

Frequency MHz	Peak dBuV	QP dBuV	QP-QP Limit dB	Avg dBuV	Avg-Avg Limit dB	Trace Name
2.408	35.2	33.1	-22.9	31.3	-14.7	Negative Trace
4.820	31.7	29.6	-26.4	28.0	-18.0	Negative Trace
9.649	28.3	26.3	-33.7	23.8	-26.2	Negative Trace
12.057	32.3	29.5	-30.5	26.1	-23.9	Negative Trace
16.879	37.0	34.6	-25.4	29.6	-20.4	Negative Trace
19.295	44.2	41.7	-18.3	33.4	-16.6	Negative Trace
21.279	27.8	25.2	-34.8	21.4	-28.6	Negative Trace
24.117	27.0	24.2	-35.8	19.1	-30.9	Negative Trace
26.519	28.2	25.6	-34.4	19.9	-30.1	Negative Trace

Plot 5.1.4.11. XB-9XR-DMUT-001 Power Line Conducted Emissions (Rx Mode)
 Line Voltage: 3.6 VDC; Line Tested: Positive

Current Graph

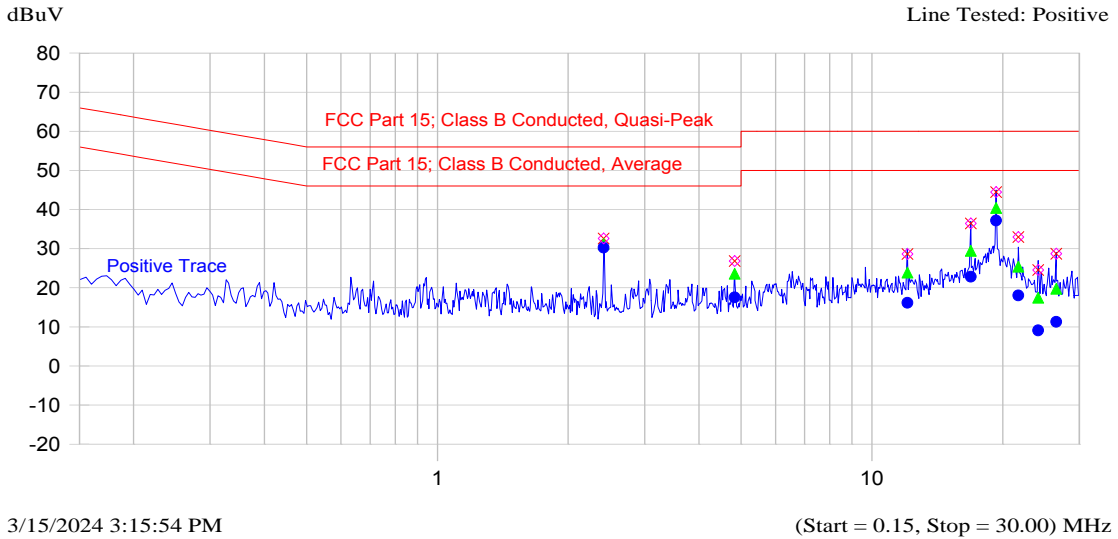

Current List

Frequency MHz	Peak dBuV	QP dBuV	QP-QP Limit dB	Avg dBuV	Avg-Avg Limit dB	Trace Name
2.414	32.6	31.2	-24.8	30.3	-15.7	Positive Trace
4.834	26.8	23.6	-32.4	17.6	-28.4	Positive Trace
12.068	28.6	23.9	-36.1	16.2	-33.8	Positive Trace
16.893	36.4	29.4	-30.6	22.8	-27.2	Positive Trace
19.310	44.5	40.4	-19.6	37.2	-12.8	Positive Trace
21.725	33.0	25.4	-34.6	18.0	-32.0	Positive Trace
24.122	24.5	17.4	-42.6	9.1	-40.9	Positive Trace
26.542	28.7	19.8	-40.2	11.3	-38.7	Positive Trace

Plot 5.1.4.12. XB-9XR-DMUT-001 Power Line Conducted Emissions (Rx Mode)
 Line Voltage: 3.6 VDC; Line Tested: Negative

Current Graph

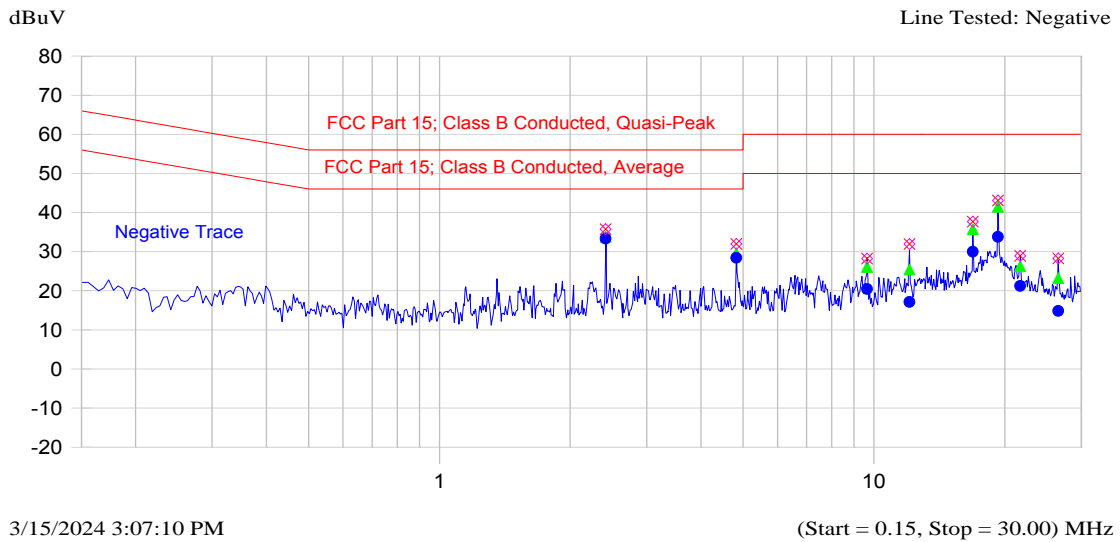

Current List

Frequency MHz	Peak dBuV	QP dBuV	QP-QP Limit dB	Avg dBuV	Avg-Avg Limit dB	Trace Name
2.413	35.8	33.8	-22.2	33.3	-12.7	Negative Trace
4.824	32.0	29.6	-26.4	28.4	-17.6	Negative Trace
9.644	28.2	26.1	-33.9	20.4	-29.6	Negative Trace
12.073	31.9	25.4	-34.6	17.1	-32.9	Negative Trace
16.878	37.7	35.7	-24.3	29.9	-20.1	Negative Trace
19.301	43.1	41.5	-18.5	33.7	-16.3	Negative Trace
21.706	28.9	26.2	-33.8	21.2	-28.8	Negative Trace
26.548	28.2	23.2	-36.8	14.8	-35.2	Negative Trace

Plot 5.1.4.13. XB-9XR-DMST-001 Power Line Conducted Emissions (Tx Mode)
 Line Voltage: 3.6 VDC; Line Tested: Positive

Current Graph

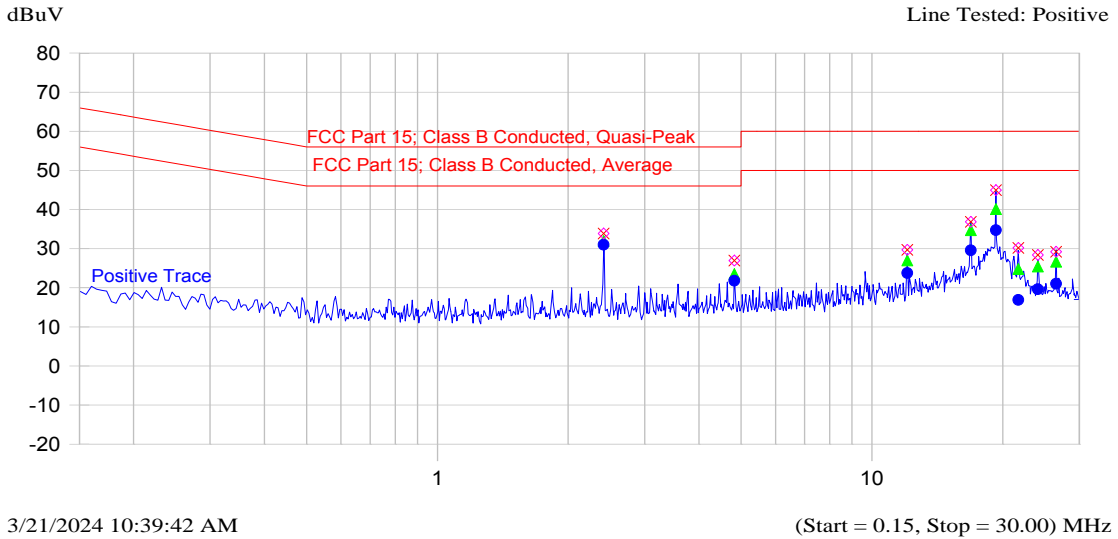

Current List

Frequency MHz	Peak dBuV	QP dBuV	QP-QP Limit dB	Avg dBuV	Avg-Avg Limit dB	Trace Name
2.412	33.8	31.9	-24.1	31.0	-15.0	Positive Trace
4.823	26.9	23.5	-32.5	21.8	-24.2	Positive Trace
12.055	29.7	27.0	-33.0	23.8	-26.2	Positive Trace
16.877	36.8	34.7	-25.3	29.6	-20.4	Positive Trace
19.297	44.9	40.1	-19.9	34.7	-15.3	Positive Trace
21.715	30.2	24.8	-35.2	16.9	-33.1	Positive Trace
24.103	28.4	25.4	-34.6	19.6	-30.4	Positive Trace
26.514	29.2	26.7	-33.3	21.0	-29.0	Positive Trace

Plot 5.1.4.14. XB-9XR-DMST-001 Power Line Conducted Emissions (Tx Mode)
 Line Voltage: 3.6 VDC; Line Tested: Negative

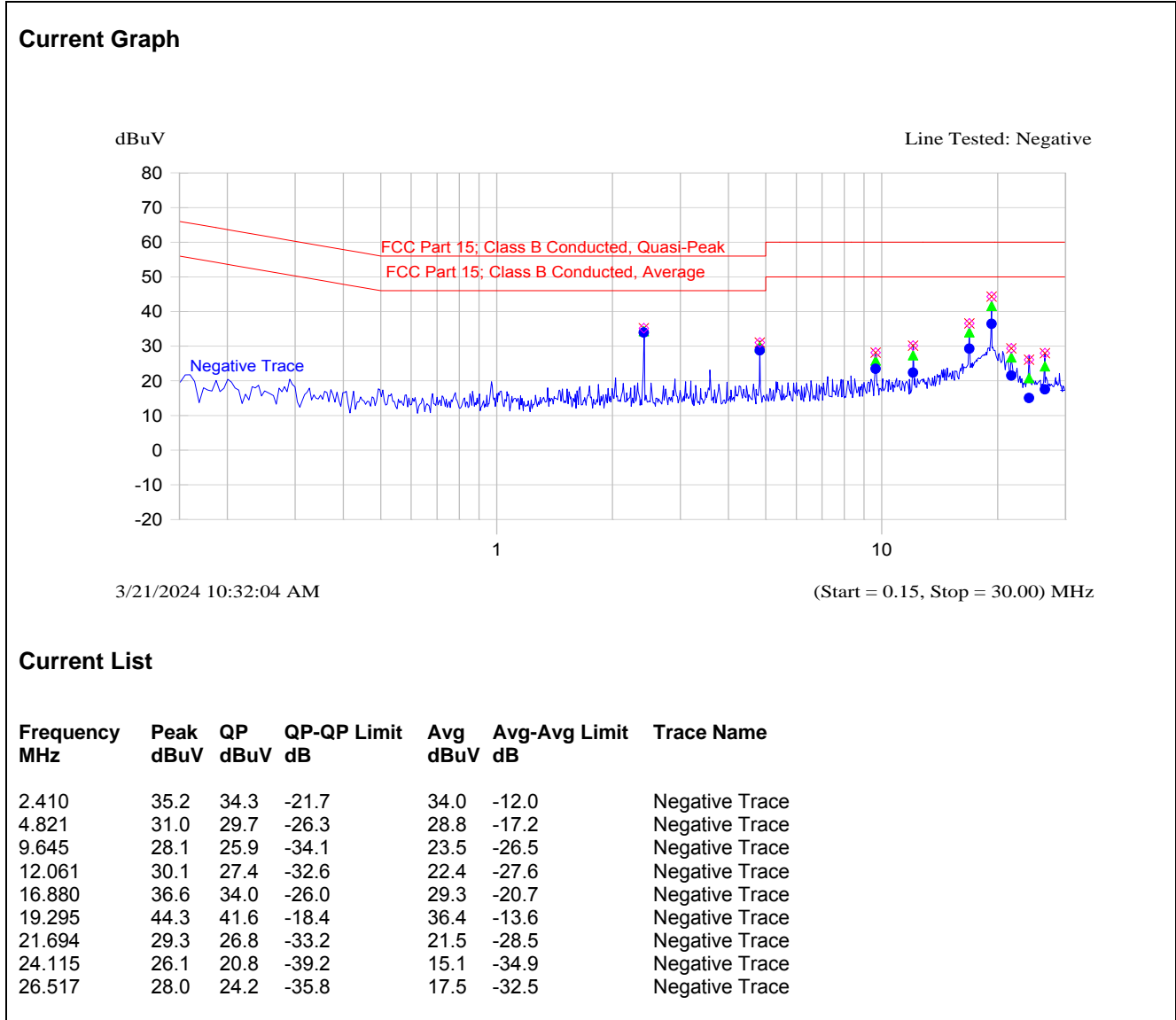

Plot 5.1.4.15. XB-9XR-DMST-001 Power Line Conducted Emissions (Rx Mode)
 Line Voltage: 3.6 VDC; Line Tested: Positive

Current Graph

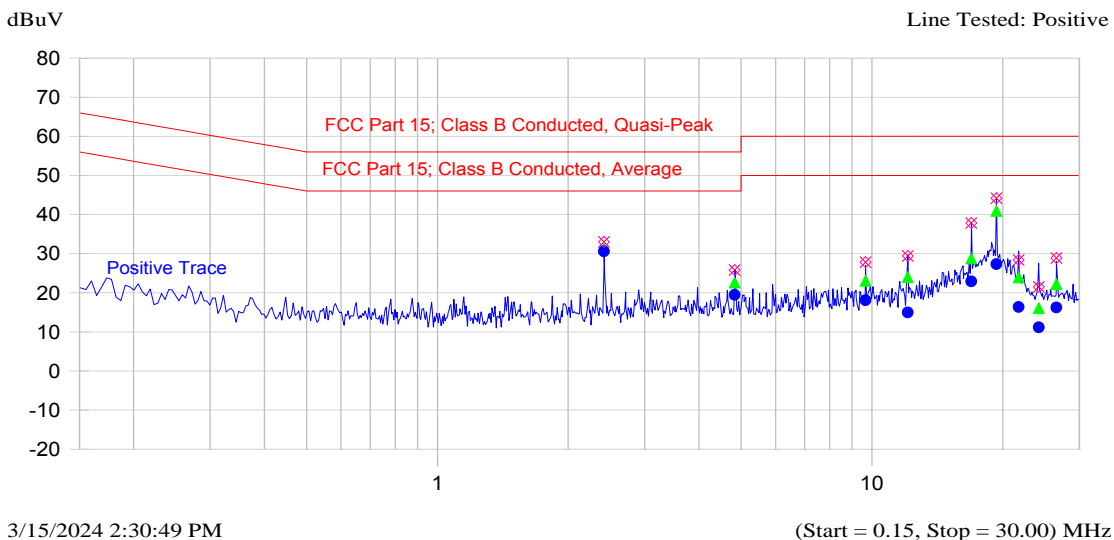

Current List

Frequency MHz	Peak dBuV	QP dBuV	QP-QP Limit dB	Avg dBuV	Avg-Avg Limit dB	Trace Name
2.417	33.0	31.4	-24.6	30.6	-15.4	Positive Trace
4.835	25.8	22.6	-33.4	19.5	-26.5	Positive Trace
9.669	27.8	23.1	-36.9	18.1	-31.9	Positive Trace
12.091	29.4	24.0	-36.0	14.9	-35.1	Positive Trace
16.924	37.9	28.8	-31.2	22.9	-27.1	Positive Trace
19.335	44.1	40.9	-19.1	27.3	-22.7	Positive Trace
21.757	28.4	23.9	-36.1	16.3	-33.7	Positive Trace
24.198	21.5	16.0	-44.0	11.1	-38.9	Positive Trace
26.582	28.8	22.2	-37.8	16.2	-33.8	Positive Trace

Plot 5.1.4.16. XB-9XR-DMST-001 Power Line Conducted Emissions (Rx Mode)
 Line Voltage: 3.6 VDC; Line Tested: Negative

Current Graph

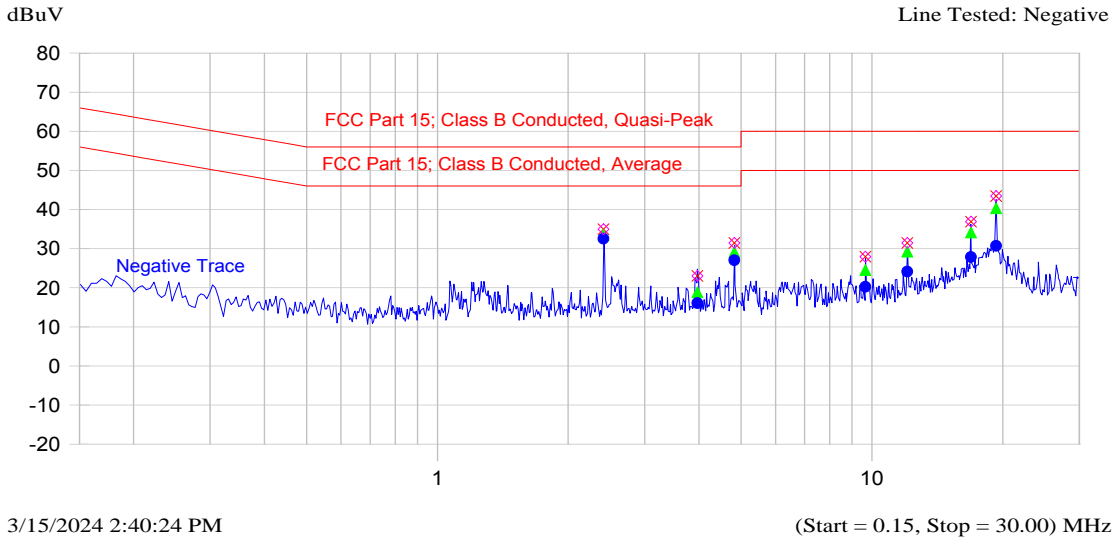

Current List

Frequency MHz	Peak dBuV	QP dBuV	QP-QP Limit dB	Avg dBuV	Avg-Avg Limit dB	Trace Name
2.412	35.0	33.5	-22.5	32.5	-13.5	Negative Trace
3.966	23.0	18.9	-37.1	16.1	-29.9	Negative Trace
4.822	31.4	29.1	-26.9	27.0	-19.0	Negative Trace
9.656	27.9	24.5	-35.5	20.3	-29.7	Negative Trace
12.065	31.4	29.2	-30.8	24.1	-25.9	Negative Trace
16.897	36.9	34.1	-25.9	27.8	-22.2	Negative Trace
19.312	43.4	40.3	-19.7	30.7	-19.3	Negative Trace

Plot 5.1.4.17. XB-9XR-DMCS-001 Power Line Conducted Emissions (Tx Mode)
 Line Voltage: 3.6 VDC; Line Tested: Positive

Current Graph

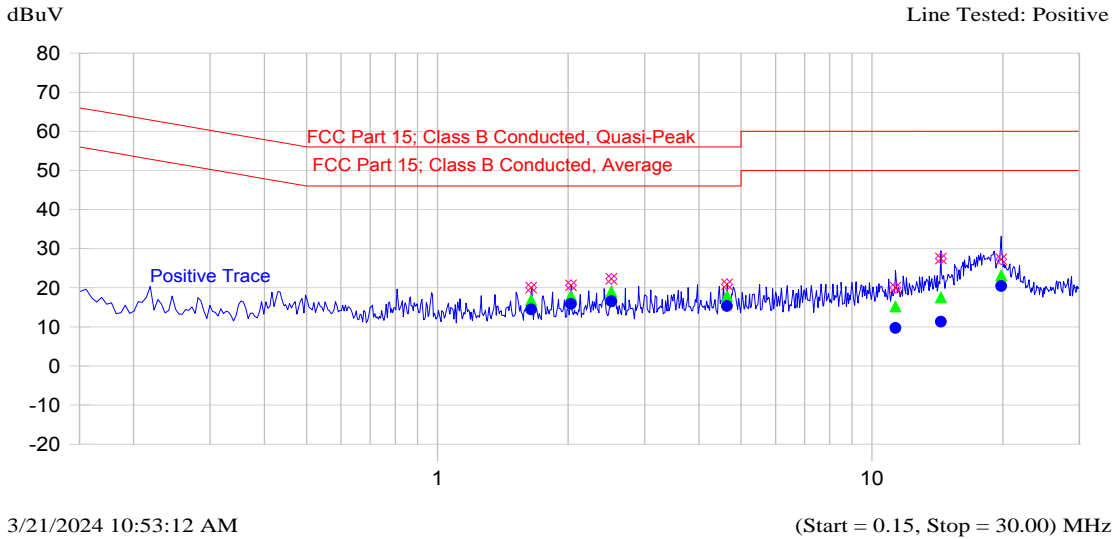

Current List

Frequency MHz	Peak dBuV	QP dBuV	QP-QP Limit dB	Avg dBuV	Avg-Avg Limit dB	Trace Name
1.642	20.1	16.8	-39.2	14.4	-31.6	Positive Trace
2.031	20.6	17.9	-38.1	15.9	-30.1	Positive Trace
2.514	22.3	19.0	-37.0	16.5	-29.5	Positive Trace
4.640	20.8	17.8	-38.2	15.3	-30.7	Positive Trace
11.324	20.0	15.2	-44.8	9.7	-40.3	Positive Trace
14.405	27.5	17.5	-42.5	11.3	-38.7	Positive Trace
19.827	27.3	23.1	-36.9	20.4	-29.6	Positive Trace

Plot 5.1.4.18. XB-9XR-DMCS-001 Power Line Conducted Emissions (Tx Mode)
 Line Voltage: 3.6 VDC; Line Tested: Negative

Current Graph

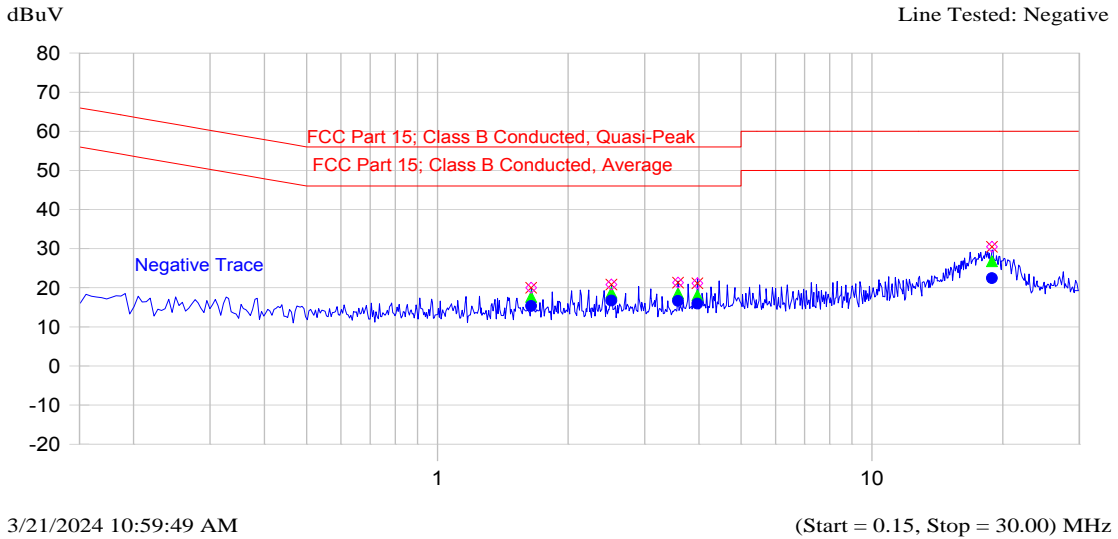

Current List

Frequency MHz	Peak dBuV	QP dBuV	QP-QP Limit dB	Avg dBuV	Avg-Avg Limit dB	Trace Name
1.643	20.0	17.7	-38.3	15.3	-30.7	Negative Trace
2.514	20.8	18.7	-37.3	16.7	-29.3	Negative Trace
3.578	21.3	18.6	-37.4	16.6	-29.4	Negative Trace
3.967	21.1	18.1	-37.9	16.0	-30.0	Negative Trace
18.873	30.5	26.8	-33.2	22.5	-27.5	Negative Trace

Plot 5.1.4.19. XB-9XR-DMCS-001 Power Line Conducted Emissions (Rx Mode)
 Line Voltage: 3.6 VDC; Line Tested: Positive

Current Graph

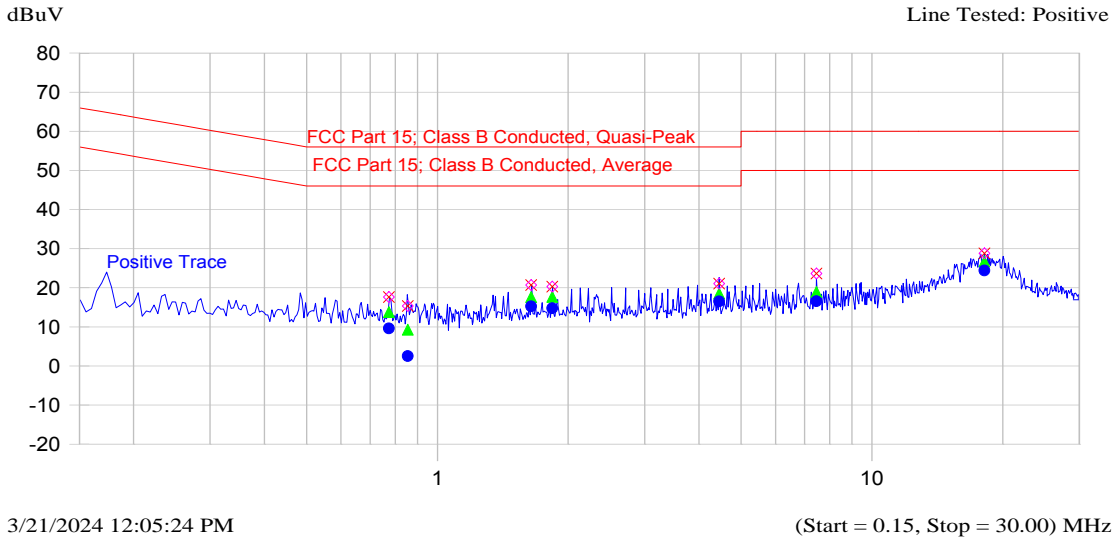

Current List

Frequency MHz	Peak dBuV	QP dBuV	QP-QP Limit dB	Avg dBuV	Avg-Avg Limit dB	Trace Name
0.774	17.6	13.8	-42.2	9.6	-36.4	Positive Trace
0.855	15.3	9.3	-46.7	2.5	-43.5	Positive Trace
1.644	20.7	17.6	-38.4	15.2	-30.8	Positive Trace
1.837	20.3	17.6	-38.4	14.7	-31.3	Positive Trace
4.449	21.1	18.5	-37.5	16.5	-29.5	Positive Trace
7.448	23.6	18.9	-41.1	16.5	-33.5	Positive Trace
18.135	28.8	26.7	-33.3	24.4	-25.6	Positive Trace

Plot 5.1.4.20. XB-9XR-DMCS-001 Power Line Conducted Emissions (Rx Mode)
 Line Voltage: 3.6 VDC; Line Tested: Negative

Current Graph

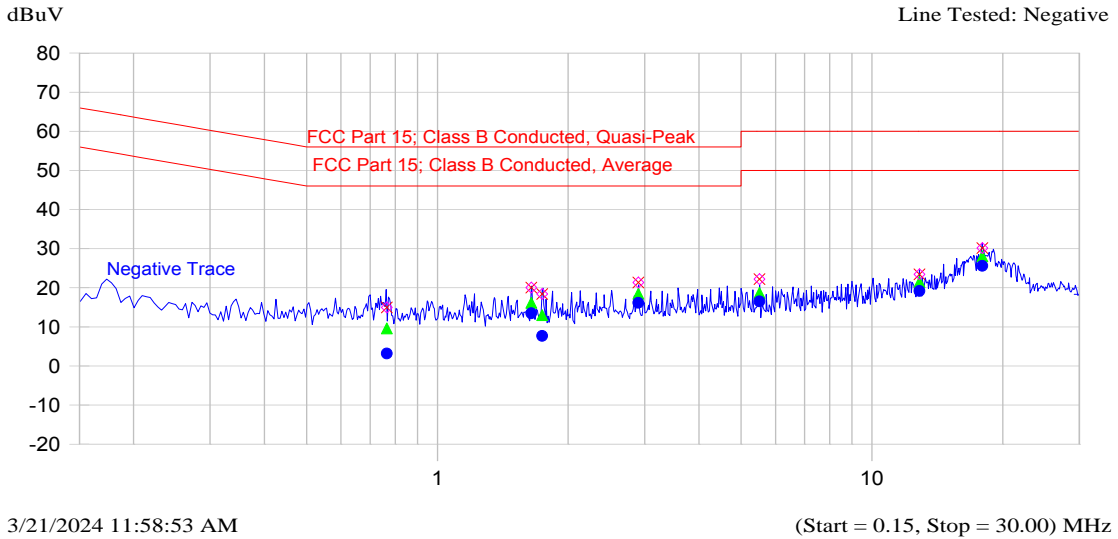

Current List

Frequency MHz	Peak dBuV	QP dBuV	QP-QP Limit dB	Avg dBuV	Avg-Avg Limit dB	Trace Name
0.766	14.9	9.6	-46.4	3.2	-42.8	Negative Trace
1.646	20.0	16.2	-39.8	13.5	-32.5	Negative Trace
1.744	18.4	13.0	-43.0	7.7	-38.3	Negative Trace
2.902	21.3	18.5	-37.5	16.1	-29.9	Negative Trace
5.513	22.2	18.7	-41.3	16.5	-33.5	Negative Trace
12.863	23.4	21.5	-38.5	19.2	-30.8	Negative Trace
17.941	30.1	28.0	-32.0	25.6	-24.4	Negative Trace

5.2. COMPLIANCE WITH FCC PART 15 – GENERAL TECHNICAL REQUIREMENTS

FCC Section	FCC Rules	Manufacturer’s Clarification
15.203	<p>Described how the EUT complies with the requirement that either its antenna is permanently attached, or that it employs a unique antenna connector, for every antenna proposed for use with the EUT.</p> <p>The exception is in those cases where EUT must be professionally installed. In order to demonstrate that professional installation is required, the following 3 points must be addressed:</p> <ul style="list-style-type: none"> ➤ The application (or intended use) of the EUT ➤ The installation requirements of the EUT ➤ The method by which the EUT will be marketed 	The antenna employs a unique antenna connector.
15.204	<p>Provided the information for every antenna proposed for use with the EUT:</p> <ul style="list-style-type: none"> ➤ type (e.g. Yagi, patch, grid, dish, etc...), ➤ manufacturer and model number ➤ gain with reference to an isotropic radiator 	See proposed antenna listed in user manual.
15.247(a)	Description of how the EUT meets the definition of a frequency hopping spread spectrum, found in Section 2.1. Based on the technical description.	See Operational Description
15.247(a)	Pseudo Frequency Hopping Sequence: Describe how the hopping sequence is generated. Provide an example of the hopping sequence channels, in order to demonstrate that the sequence meets the requirements specified in the definition of a frequency hopping spread spectrum system, found in Section 2.1	See Operational Description
15.247(a)	Equal Hopping Frequency Use: Describe how each individual EUT meets the requirement that each of its hopping channels is used equally on average (e.g. that each new transmission event begins on the next channel in the hopping sequence after final channel used in the previous transmission events).	See Operational Description
15.247(a)	System Receiver Input Bandwidth: Describe how the associated receiver(s) complies with the requirement that its input bandwidth (either RF or IF) matches the bandwidth of the transmitted signal.	See Operational Description

FCC Section	FCC Rules	Manufacturer's Clarification
15.247(a)	<u>System Receiver Hopping Capability:</u> Describe how the associated receiver(s) has the ability to shift frequencies in synchronization with the transmitted signals	See Operational Description
15.247(g)	Describe how the EUT complies with the requirement that it be designed to be capable of operating as a true frequency hopping system	See Operational Description
15.247(h)	Describe how the EUT complies with the requirement that it not have the ability to coordinated with other FHSS is an effort to avoid the simultaneous occupancy of individual hopping frequencies by multiple transmitters	See Operational Description

5.3. PROVISIONS FOR FREQUENCY HOPPING SYSTEMS [§ 15.247(a)(1)]

5.3.1. Limits

§ 15.247(a)(1) Frequency hopping systems shall have hopping channel carrier frequencies separated by a minimum of 25 kHz or the 20 dB bandwidth of the hopping channel, whichever is greater. Alternatively, frequency hopping systems operating in the 2400-2483.5 MHz band may have hopping channel carrier frequencies that are separated by 25 kHz or two-thirds of the 20 dB bandwidth of the hopping channel, whichever is greater, provided the systems operate with an output power no greater than 125 mW. The system shall hop to channel frequencies that are selected at the system hopping rate from a pseudo randomly ordered list of hopping frequencies. Each frequency must be used equally on the average by each transmitter. The system receivers shall have input bandwidths that match the hopping channel bandwidths of their corresponding transmitters and shall shift frequencies in synchronization with the transmitted signals.

§ 15.247(a)(1)(i) For frequency hopping systems operating in the 902-928 MHz band: if the 20 dB bandwidth of the hopping channel is less than 250 kHz, the system shall use at least 50 hopping frequencies and the average time of occupancy on any frequency shall not be greater than 0.4 seconds within a 20 second period; if the 20 dB bandwidth of the hopping channel is 250 kHz or greater, the system shall use at least 25 hopping frequencies and the average time of occupancy on any frequency shall not be greater than 0.4 seconds within a 10 second period. The maximum allowed 20 dB bandwidth of the hopping channel is 500 kHz.

5.3.2. Method of Measurements

ANSI C63.10-2020, Sections 6.9.2, 7.8.2, 7.8.3 and 7.8.4

5.3.3. Test Arrangement

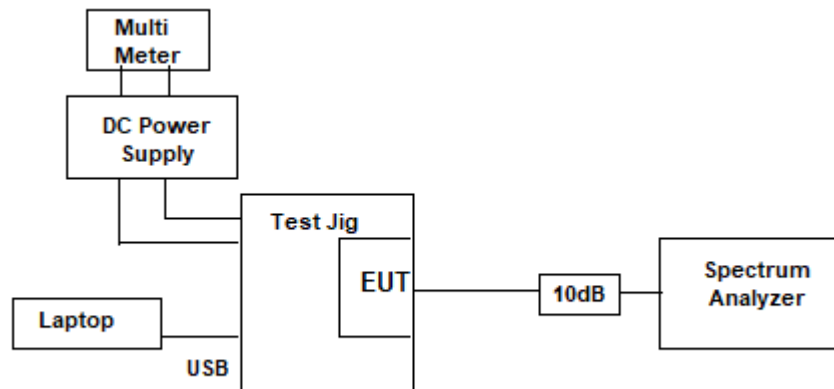

5.3.4. Test Data

Test Description	FCC Specification	Measured Values	Comments
Frequency Hopping Systems Requirements	The system shall hop to channel frequencies that are selected at the system hopping rate from a pseudo randomly ordered list of hopping frequencies. Each frequency must be used equally on the average by each transmitter. The system receivers shall have input bandwidths that match the hopping channel bandwidths of their corresponding transmitters and shall shift frequencies in synchronization with the transmitted signals.	--	See Note 1
BW of the hopping channel	The maximum allowed 20 dB bandwidth of the hopping channel is 500 kHz.	10 kbps: 78.21 kHz 110 kbps: 197.12 kHz 250 kbps: 296.47 kHz	See Note 2
Channel Hopping Frequency Separation	Frequency hopping systems shall have hopping channel carrier frequencies separated by a minimum of 25 kHz or the 20 dB bandwidth of the hopping channel, whichever is greater.	10 kbps: 500 kHz 110 kbps: 502 kHz 250 kbps: 502 kHz	See Note 2
Number of hopping frequencies	If the 20 dB bandwidth of the hopping channel is less than 250 kHz, the system shall use at least 50 hopping frequencies; if the 20 dB bandwidth of the hopping channel is 250 kHz or greater, the system shall use at least 25 hopping frequencies	50 hopping frequencies	See Note 1 and 2
Average Time of Occupancy	if the 20 dB bandwidth of the hopping channel is less than 250 kHz, the average time of occupancy on any frequency shall not be greater than 0.4 seconds within a 20 second period; if the 20 dB bandwidth of the hopping channel is 250 kHz or greater, the average time of occupancy on any frequency shall not be greater than 0.4 seconds within a 10 second period	10 kbps: 299.90 ms, within a 20 second period 110 kbps: 390.26 ms, within a 20 second period 250 kbps: 169.18 ms, within a 10 second period	See Note 2
<p>Note 1: See operational description exhibit for details. Note 2: See the following plots for details.</p>			

Plot 5.3.4.1. 20 dB Bandwidth, 902.5 MHz, 10 kbps

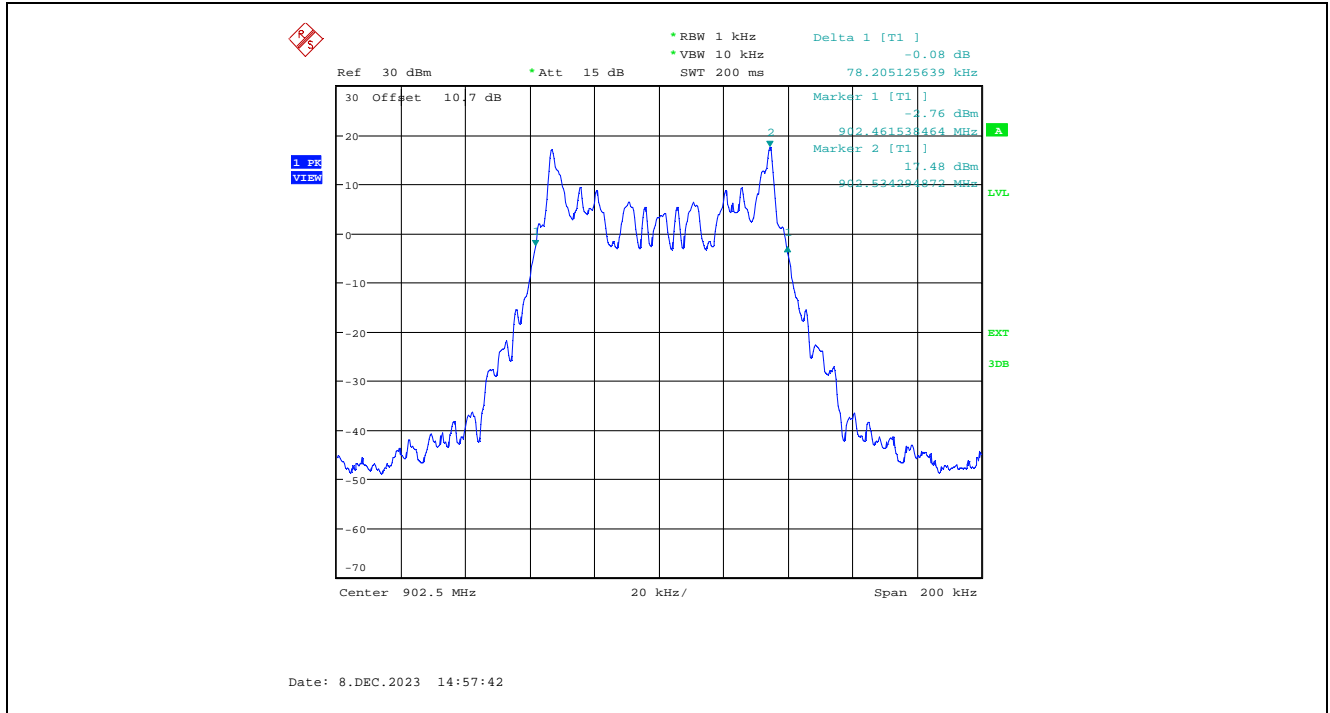

Plot 5.3.4.2. 20 dB Bandwidth, 915 MHz, MHz, 10 kbps

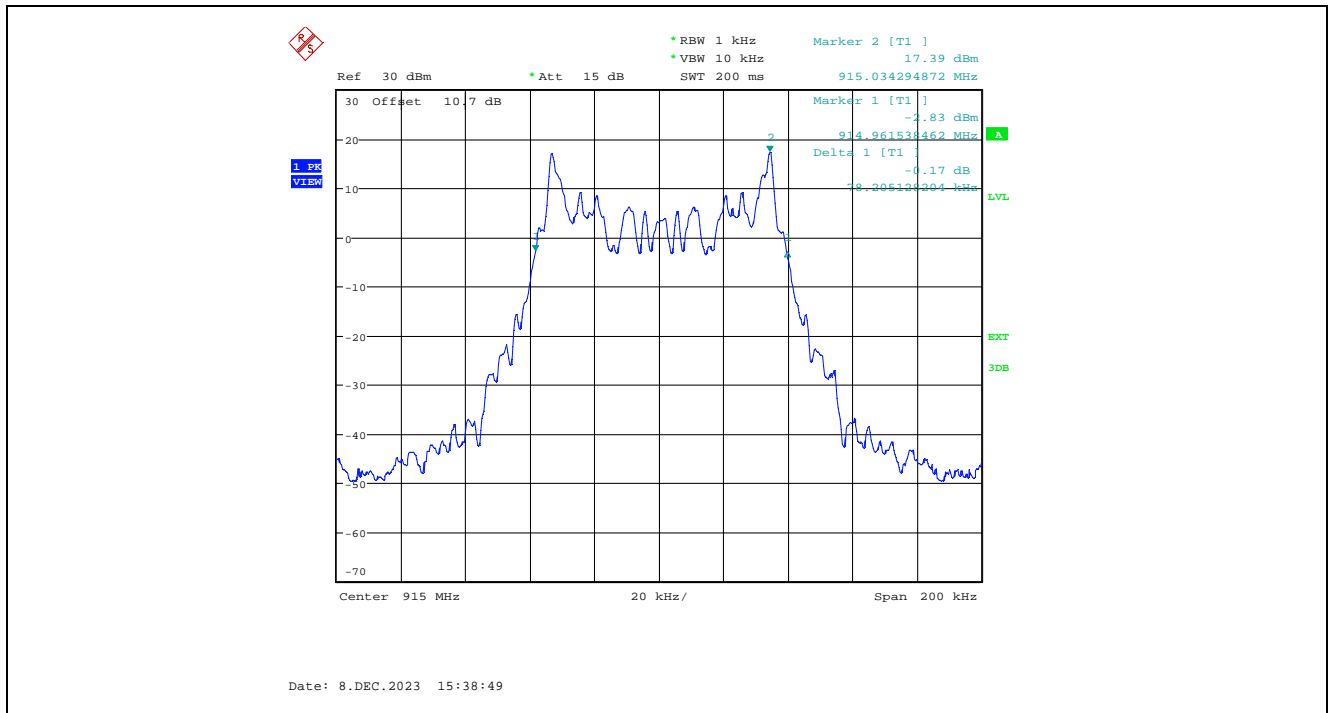

Plot 5.3.4.3. 20 dB Bandwidth, 927 MHz, MHz, 10 kbps

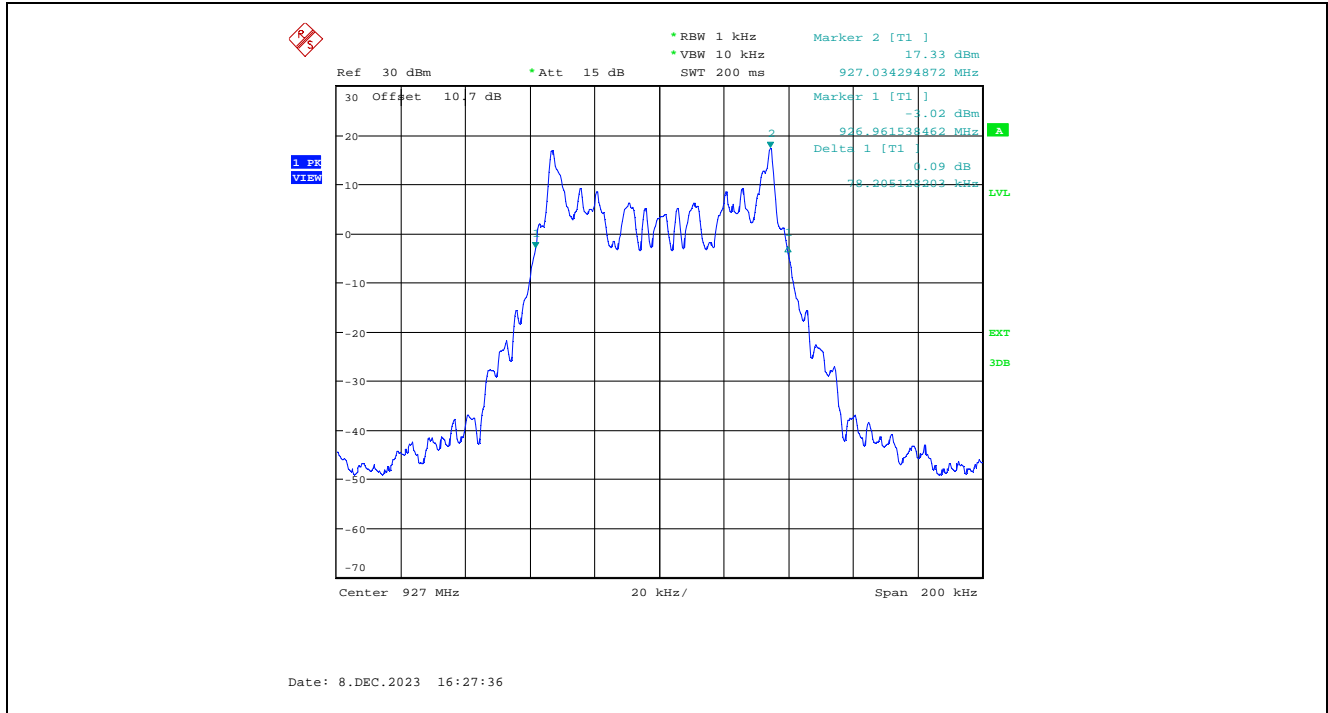

Plot 5.3.4.4. 20 dB Bandwidth, 902.5 MHz, MHz, 110 kbps

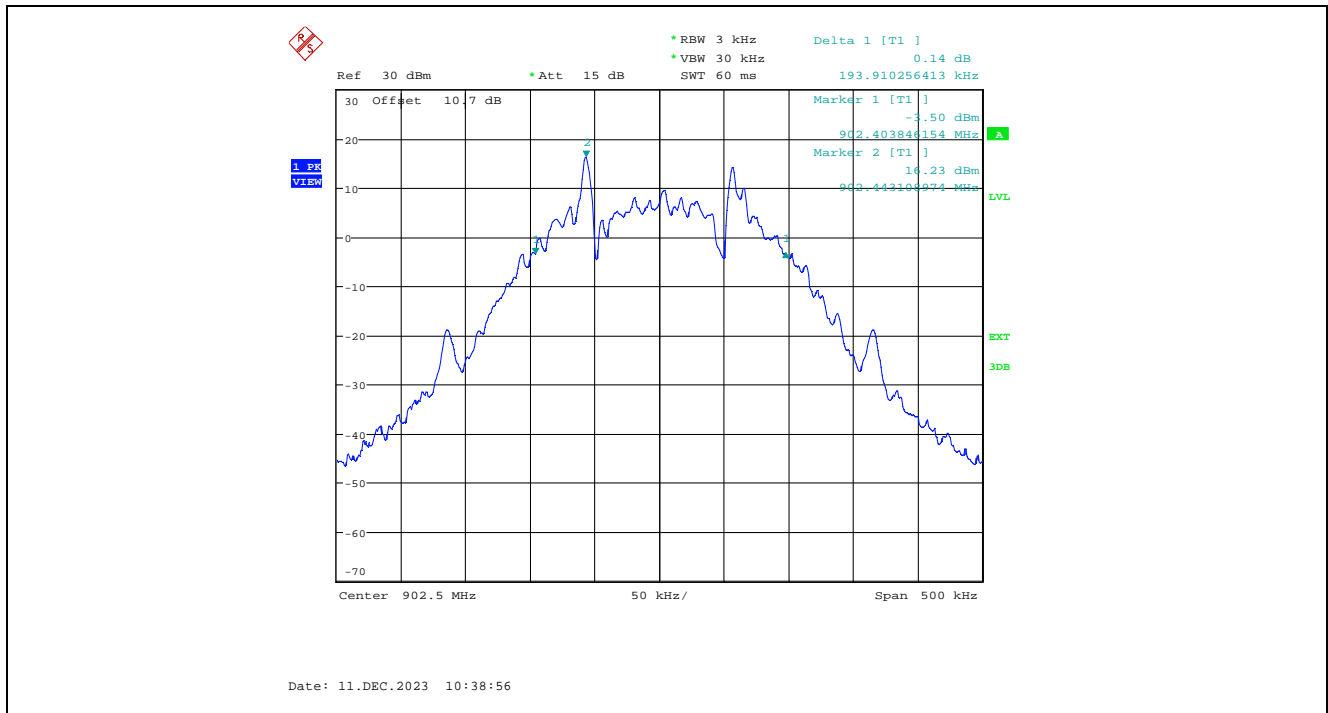

Plot 5.3.4.5. 20 dB Bandwidth, 915 MHz, MHz, 110 kbps

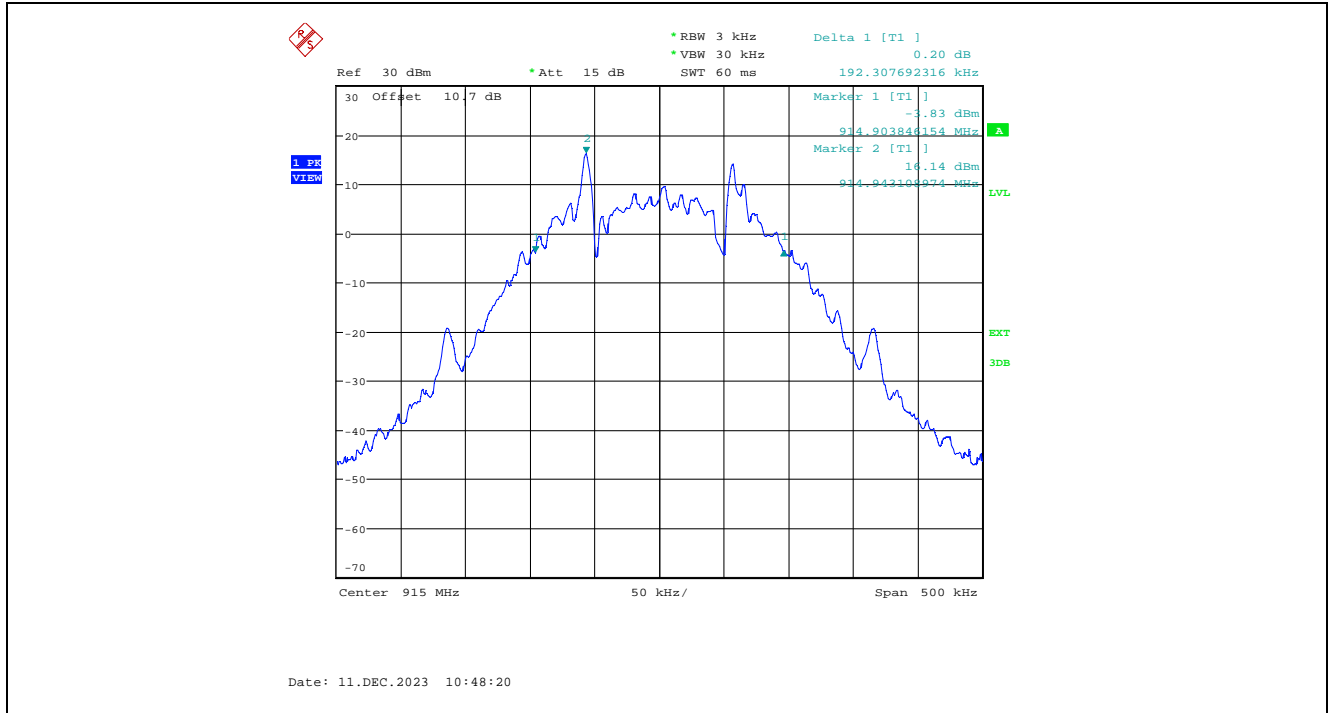

Plot 5.3.4.6. 20 dB Bandwidth, 927 MHz, MHz, 110 kbps

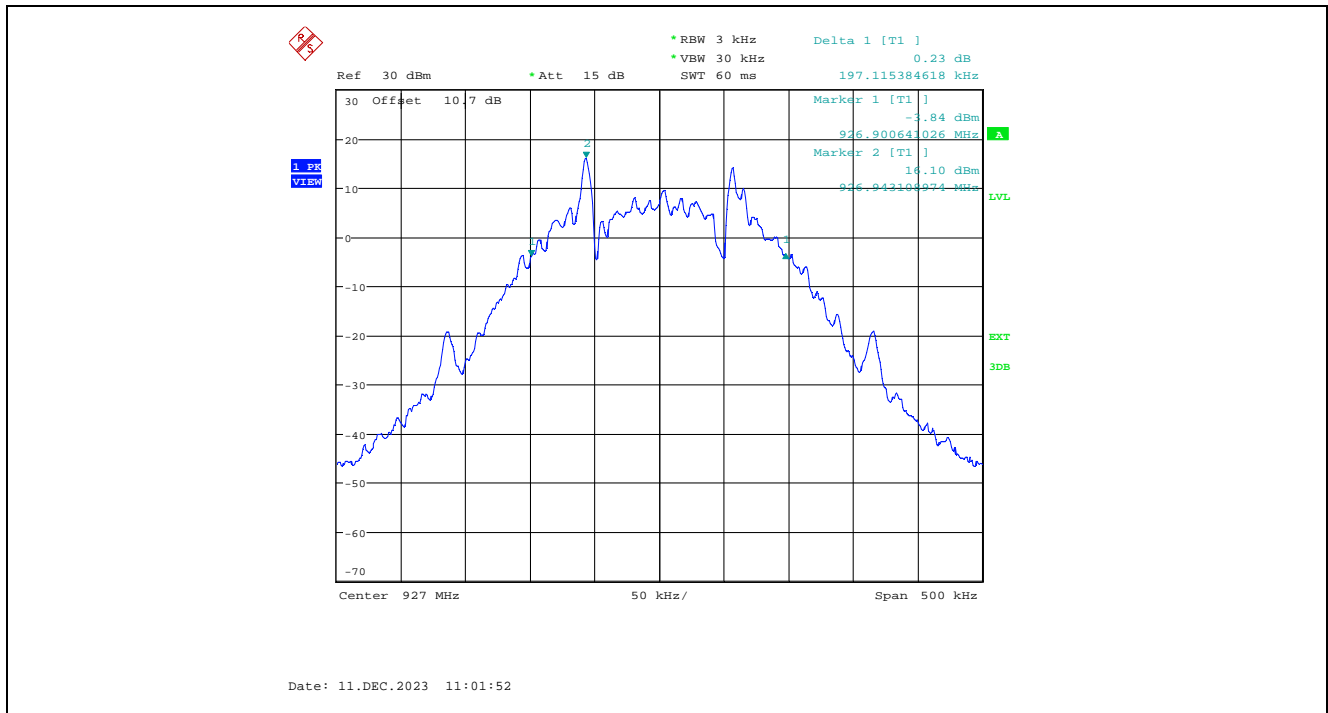

Plot 5.3.4.7. 20 dB Bandwidth, 902.75 MHz, MHz, 250 kbps

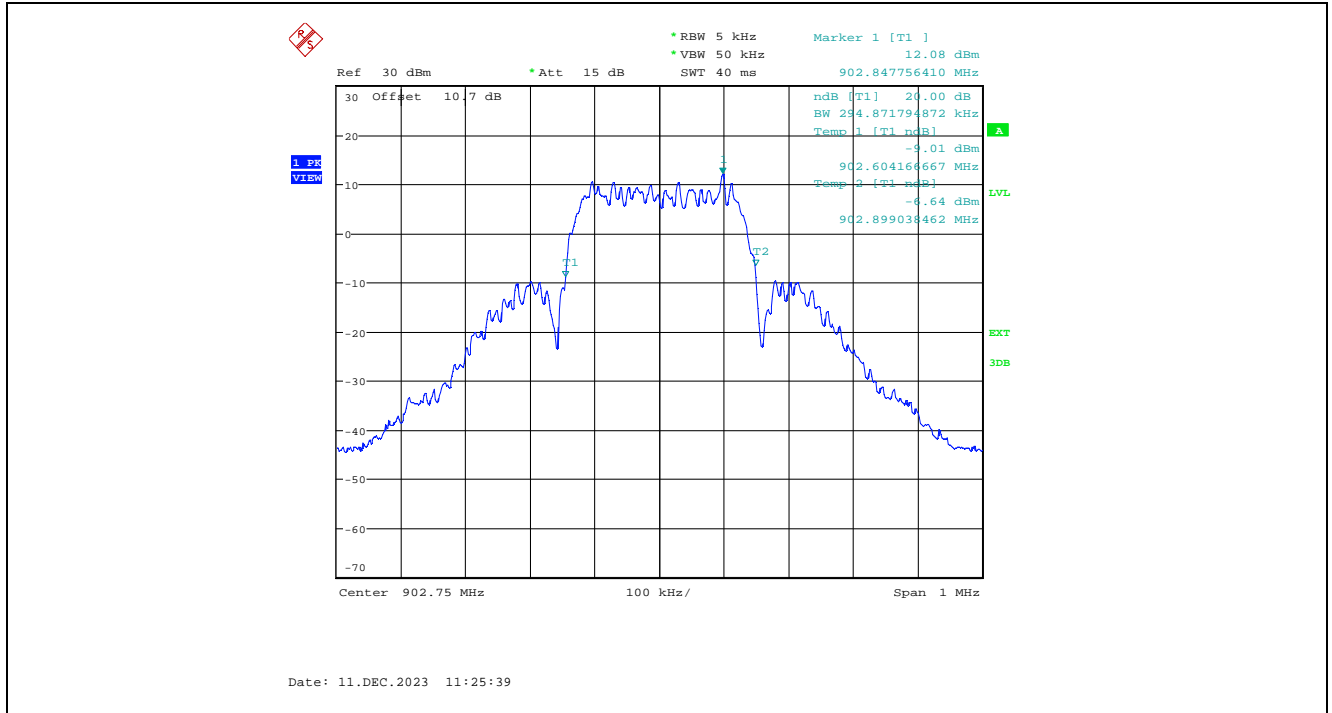

Plot 5.3.4.8. 20 dB Bandwidth, 915.25 MHz, MHz, 250 kbps

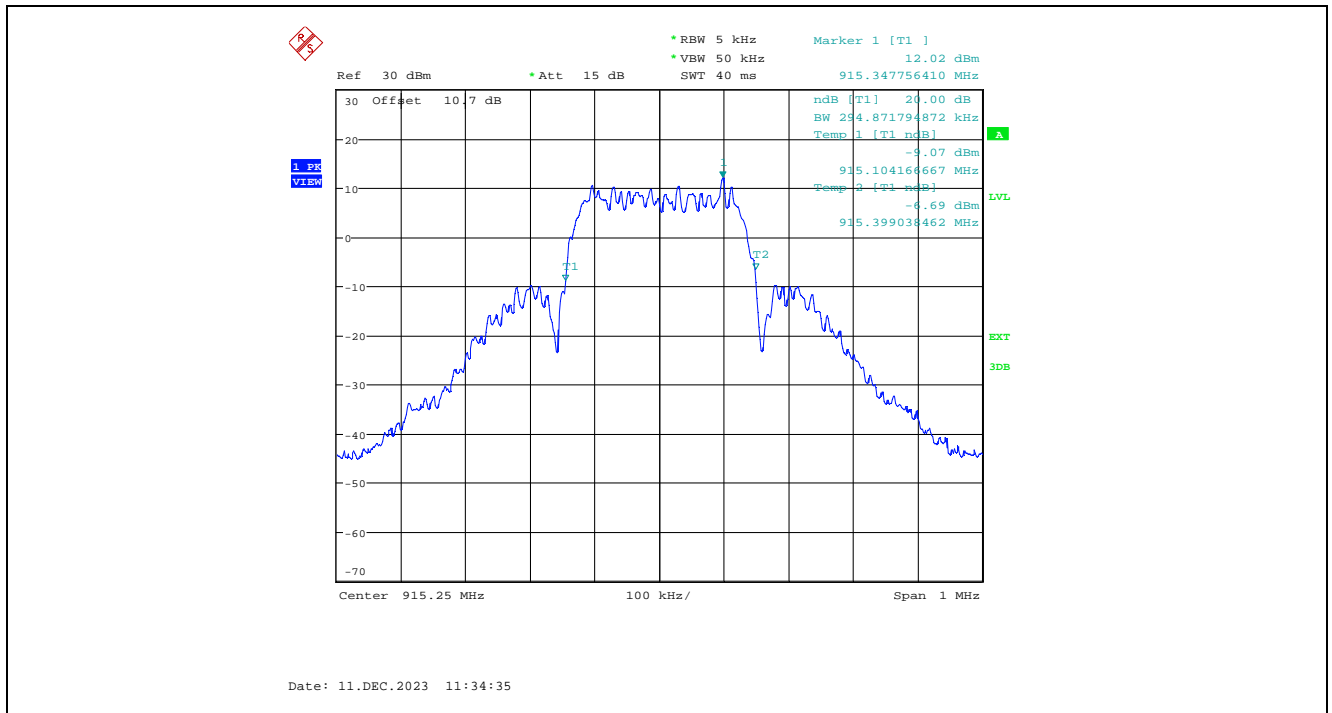

Plot 5.3.4.9. 20 dB Bandwidth, 927.25 MHz, MHz, 250 kbps

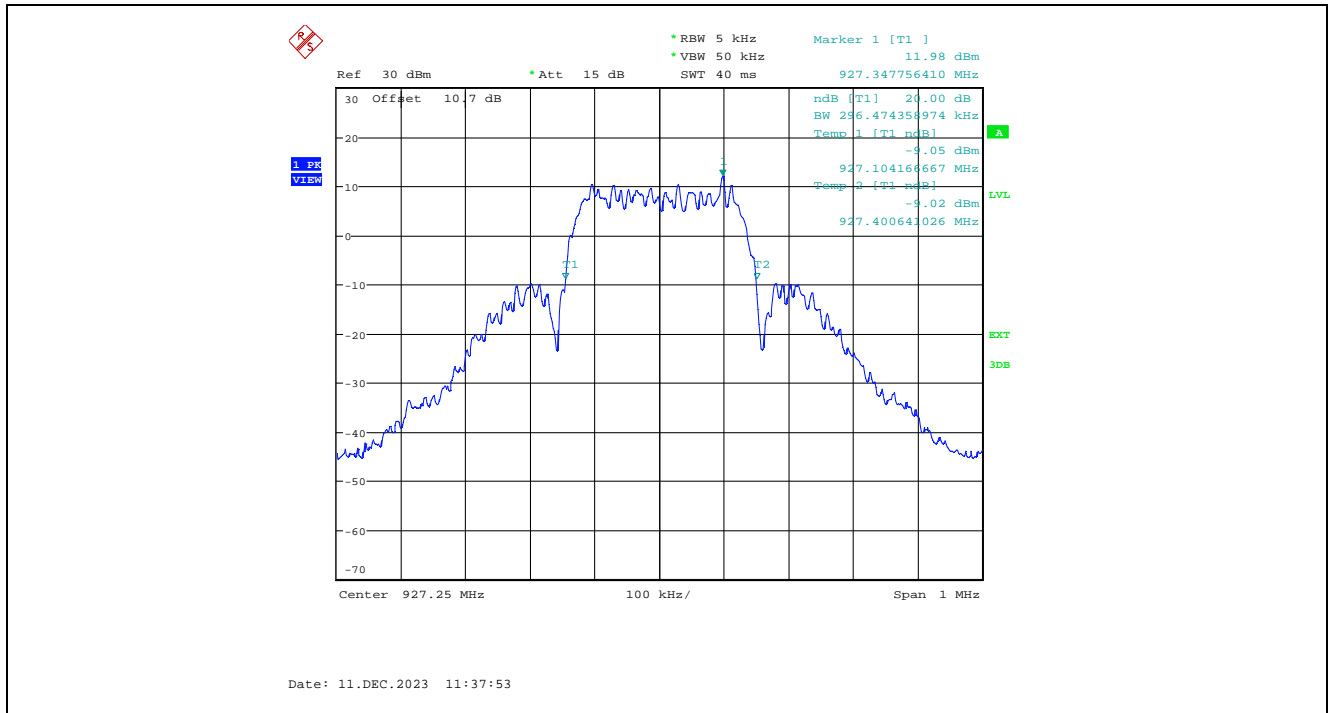

Plot 5.3.4.10. Carrier Frequency Separation, 10 kbps

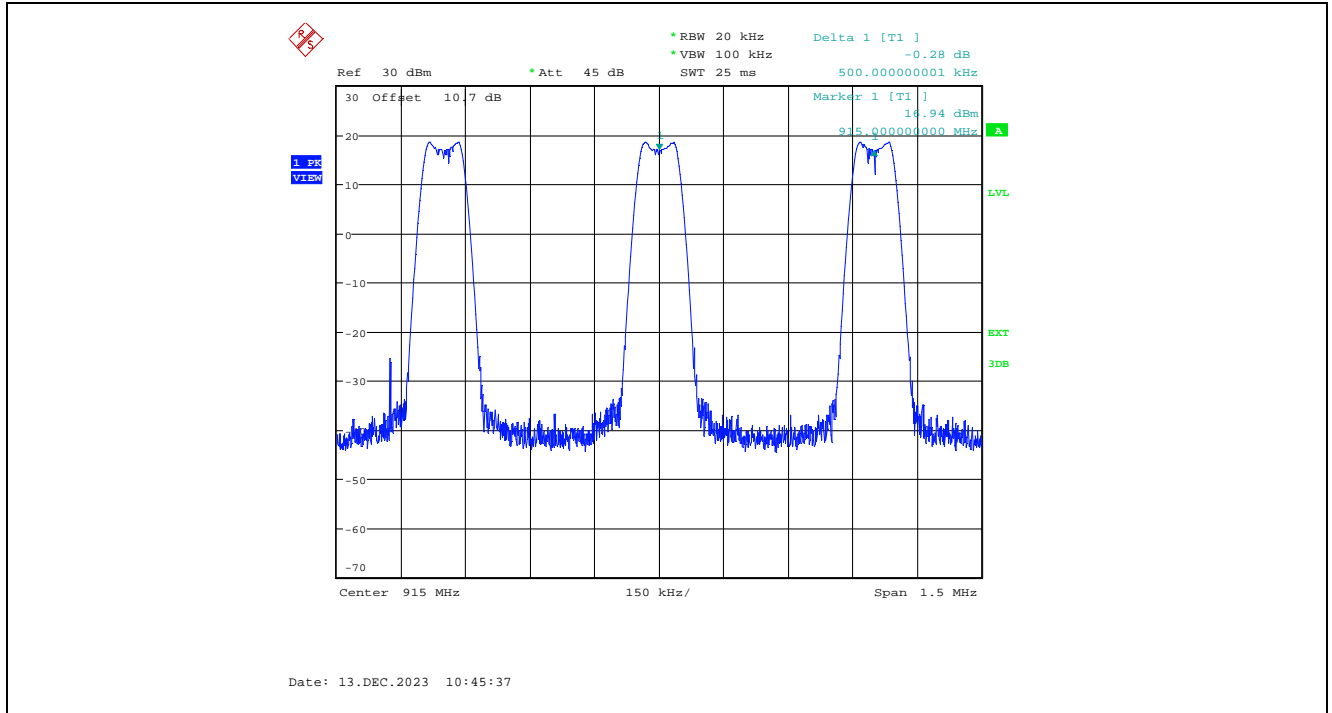

Plot 5.3.4.11. Carrier Frequency Separation, 110 kbps

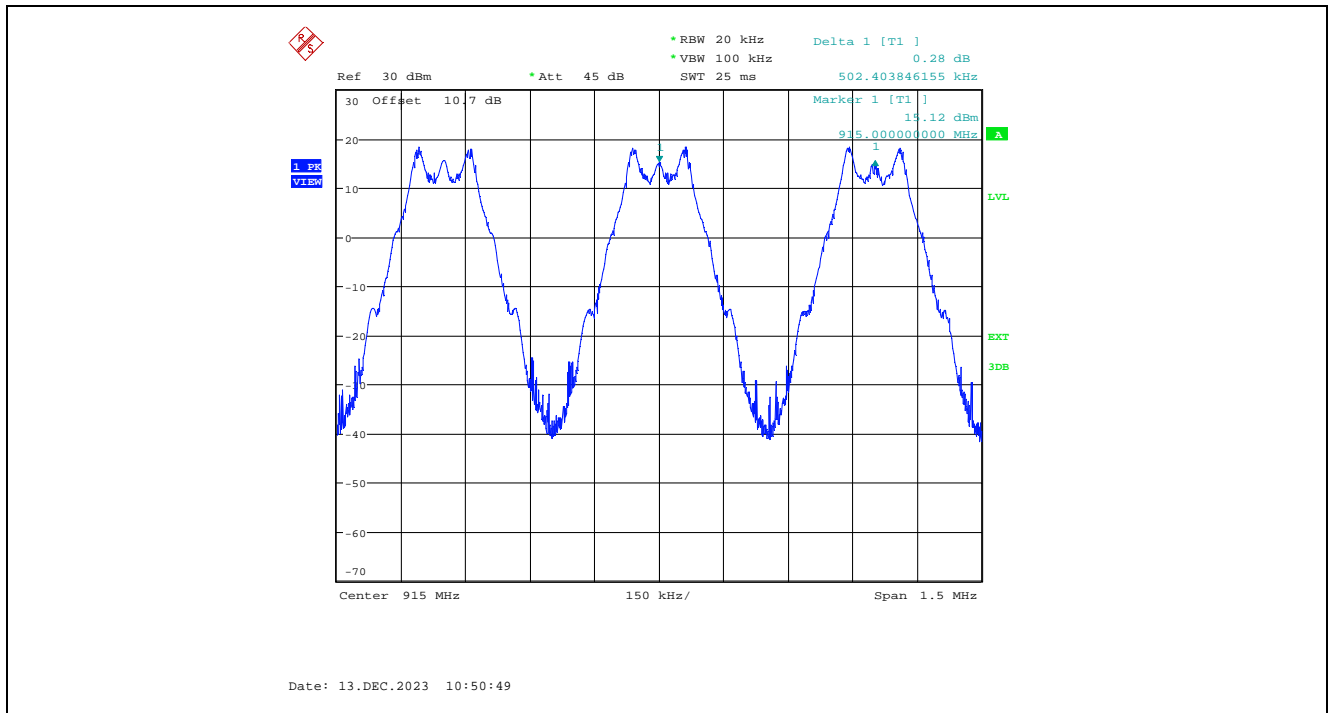

Plot 5.3.4.12. Carrier Frequency Separation, 250 kbps

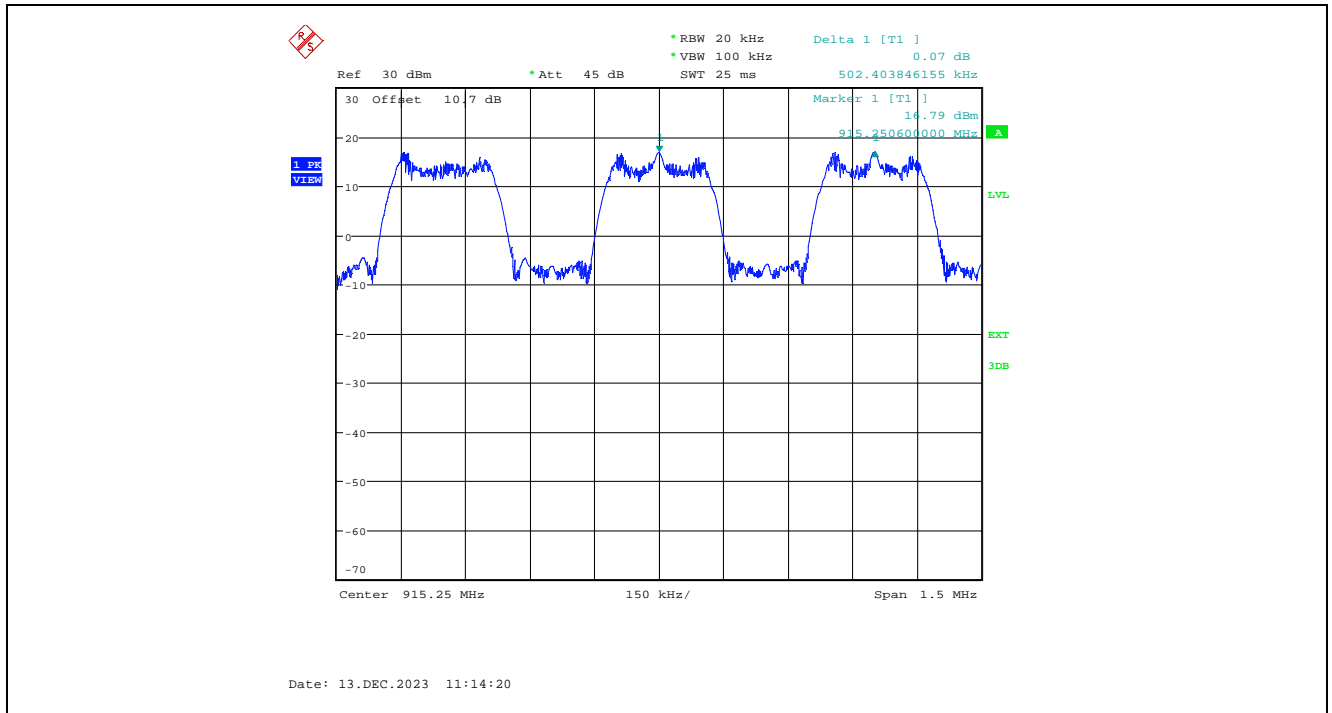

Plot 5.3.4.13. Number of Hopping Frequencies, 10 kbps
50 Hopping Channels

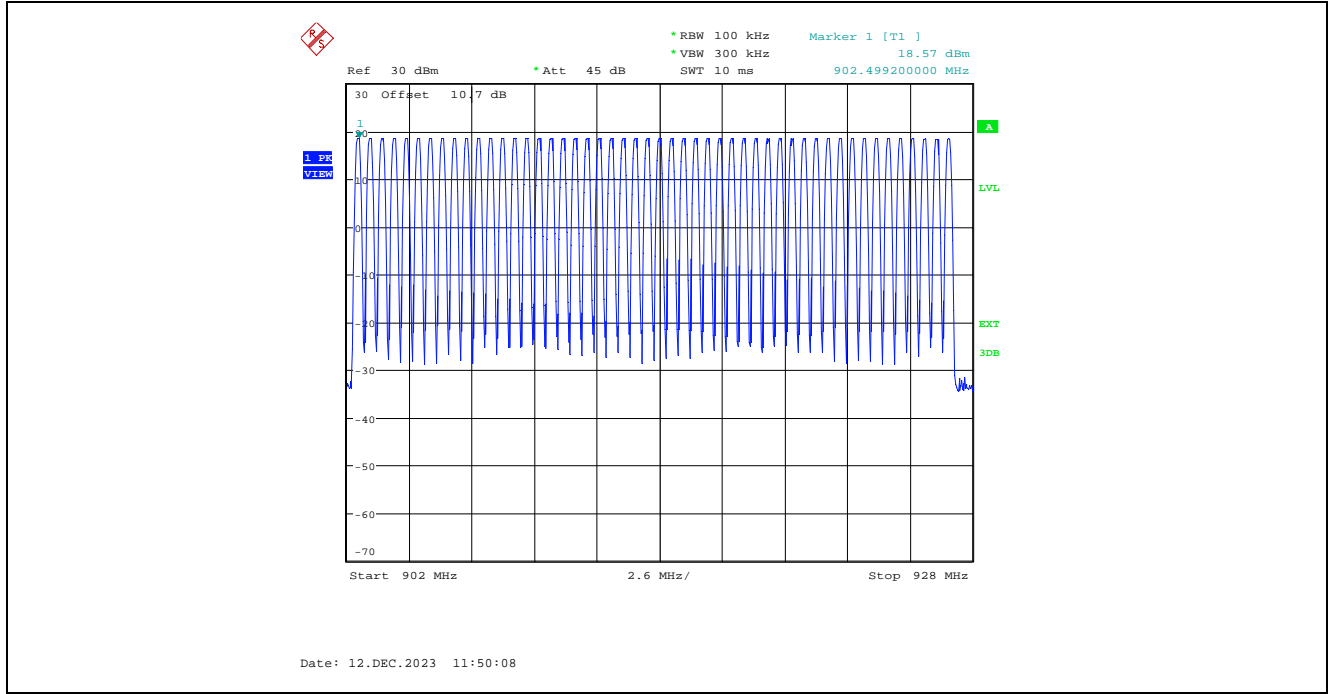

Plot 5.3.4.14. Number of Hopping Frequencies, 110 kbps
50 Hopping Channels

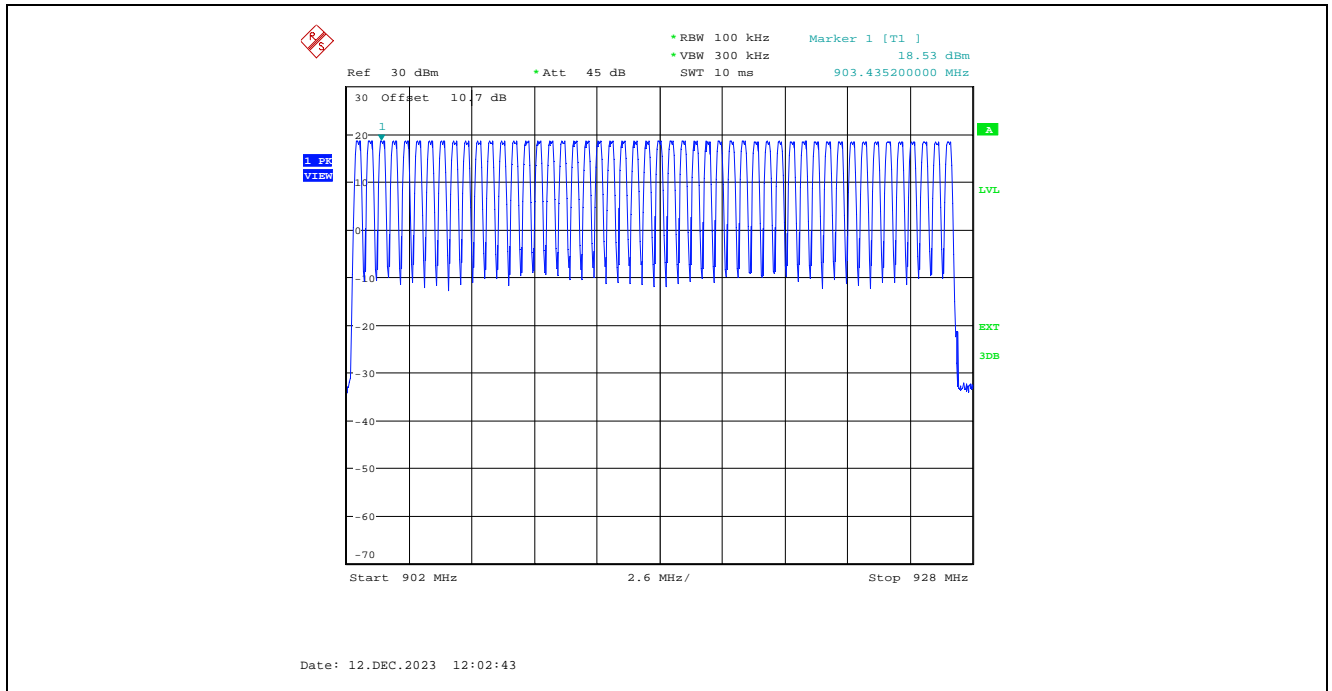

Plot 5.3.4.15. Number of Hopping Frequencies, 250 kbps
50 Hopping Channels

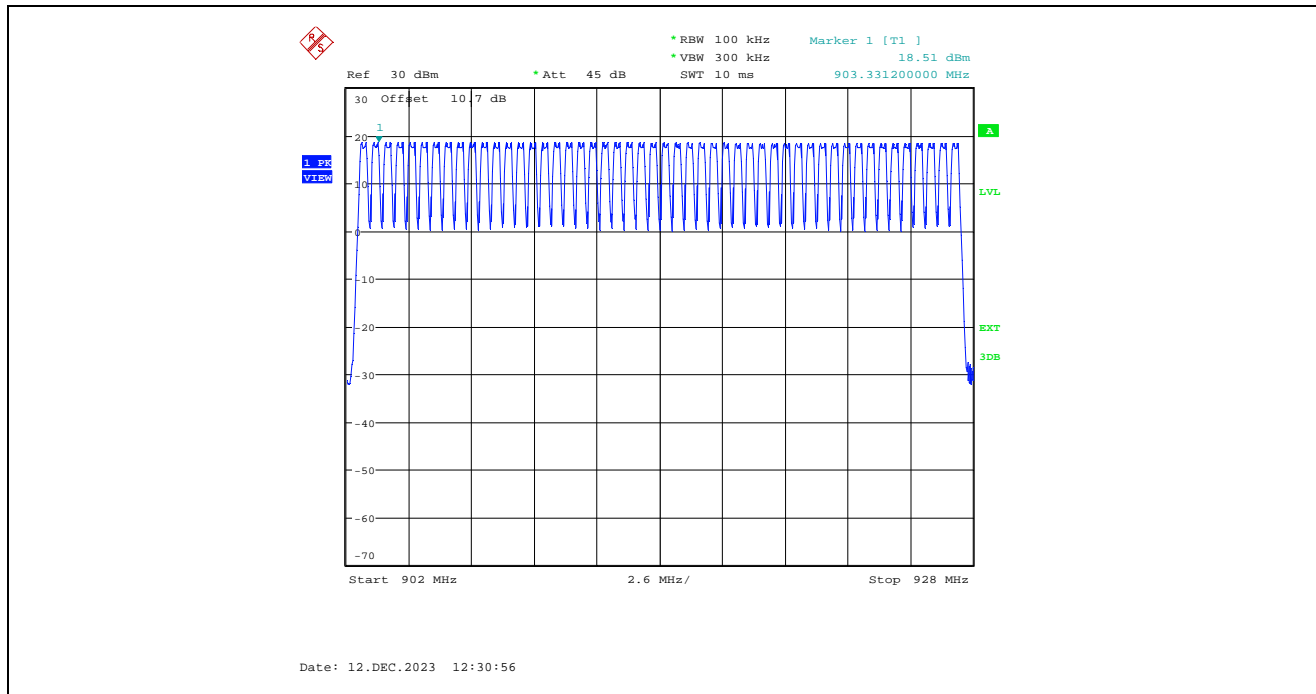

Plot 5.3.4.16. Time of Occupancy, 902.5 MHz, 10 kbps
Dwell Time per hop at 902.5 MHz = 299.68 ms

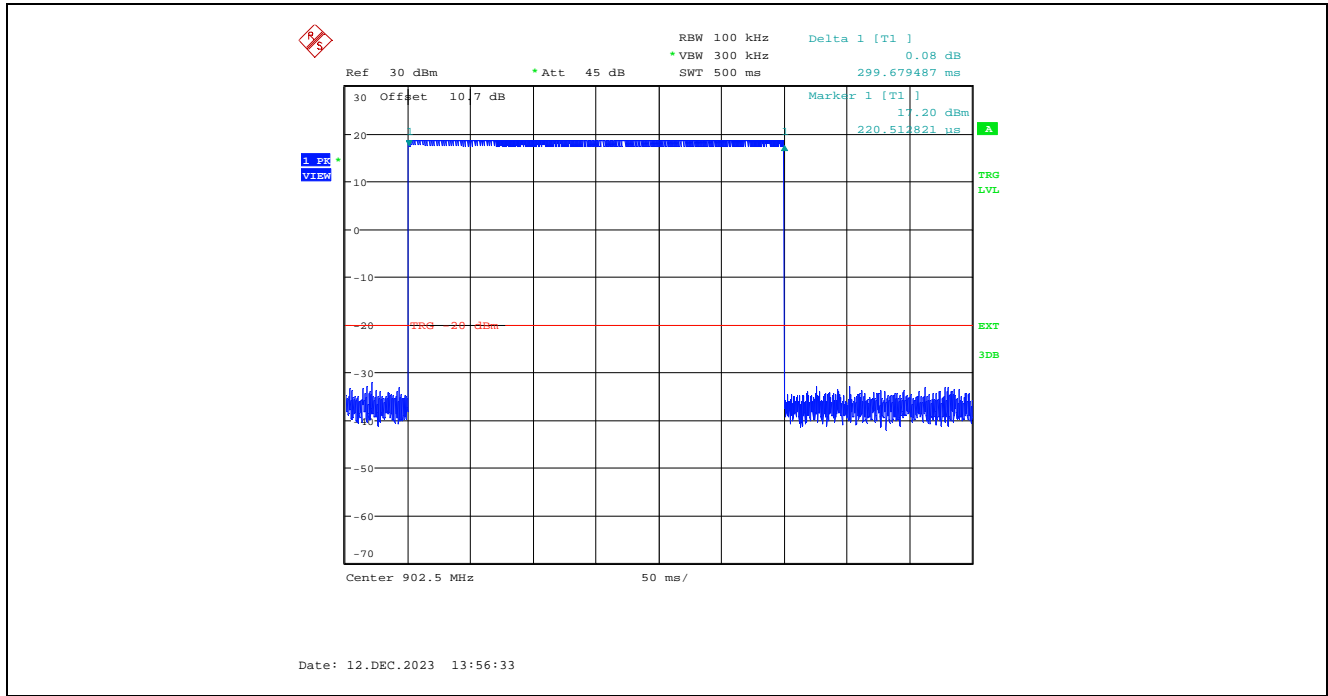

Plot 5.3.4.17. Time of Occupancy, 902.5 MHz, 10 kbps
Average time of occupancy = (Dwell Time per hop) x (number of hops within a 20s period) = 299.68 ms x 1 = 299.68 ms

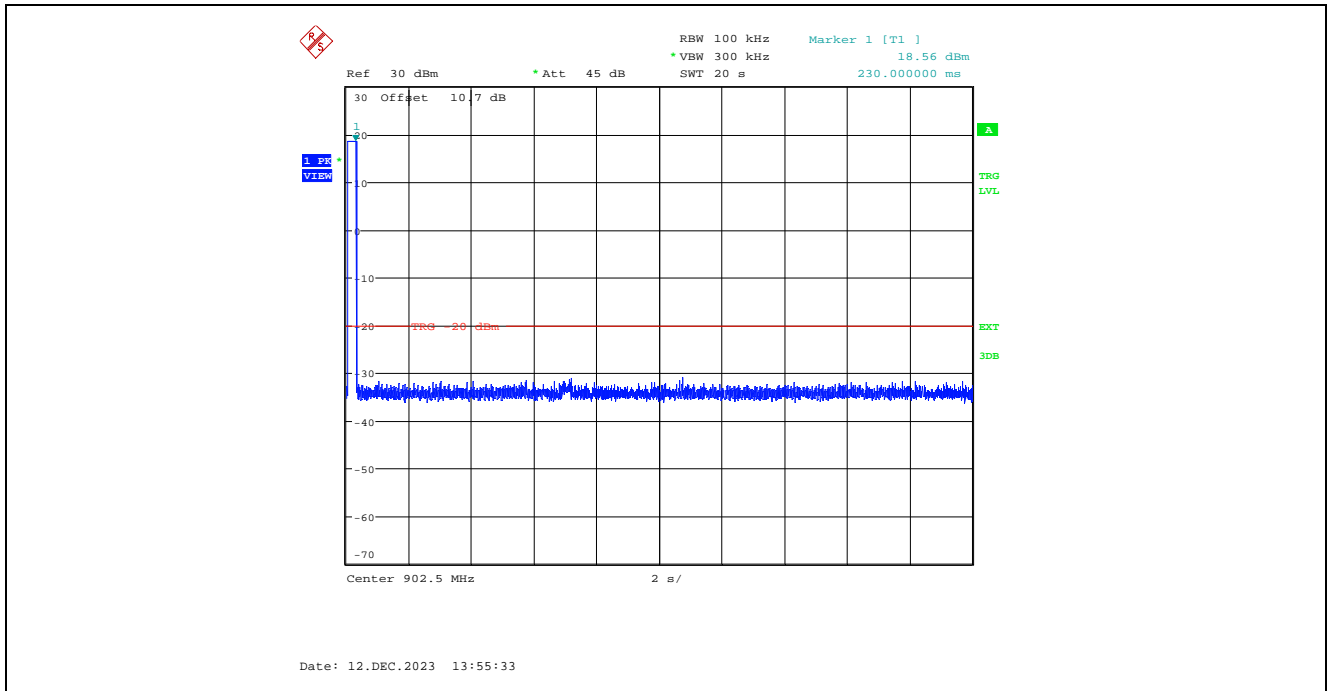

Plot 5.3.4.18. Time of Occupancy, 915 MHz, 10 kbps
Dwell Time per hop at 915 MHz = 299.68 ms

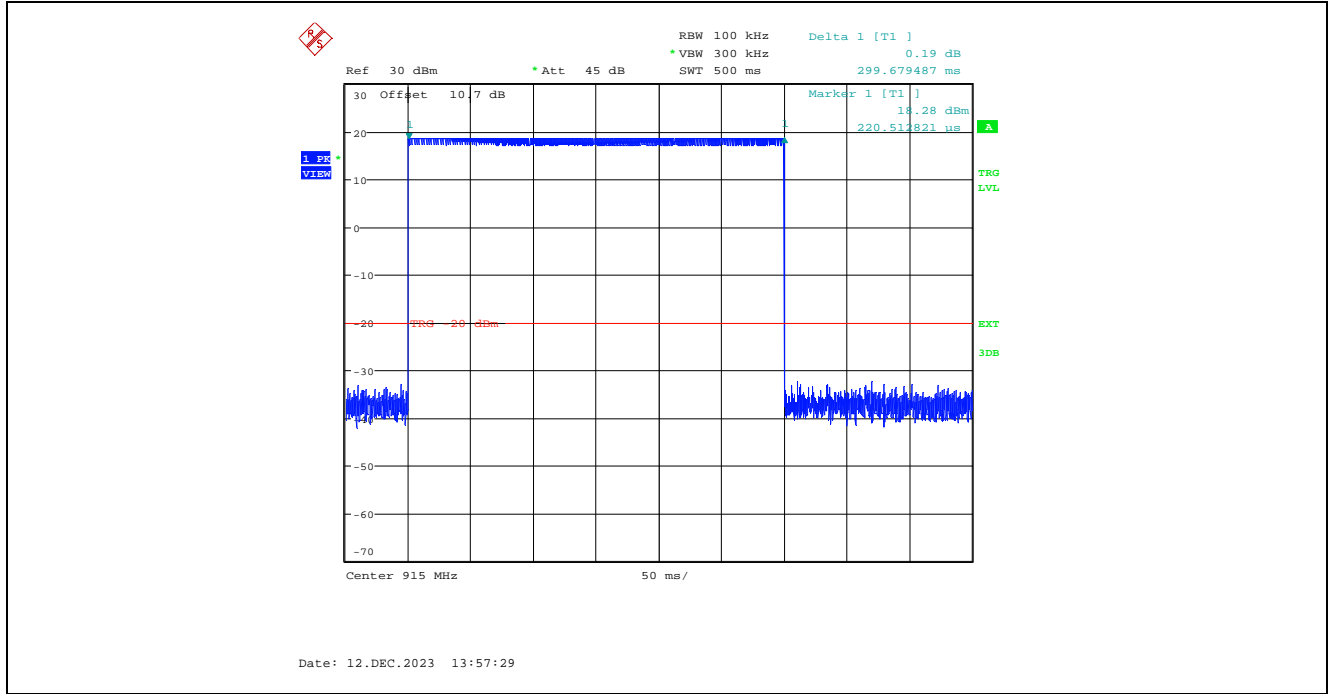

Plot 5.3.4.19. Time of Occupancy, 915 MHz, 10 kbps
Average time of occupancy = (Dwell Time per hop) x (number of hops within a 20s period) = 299.68 ms x 1 = 299.68 ms

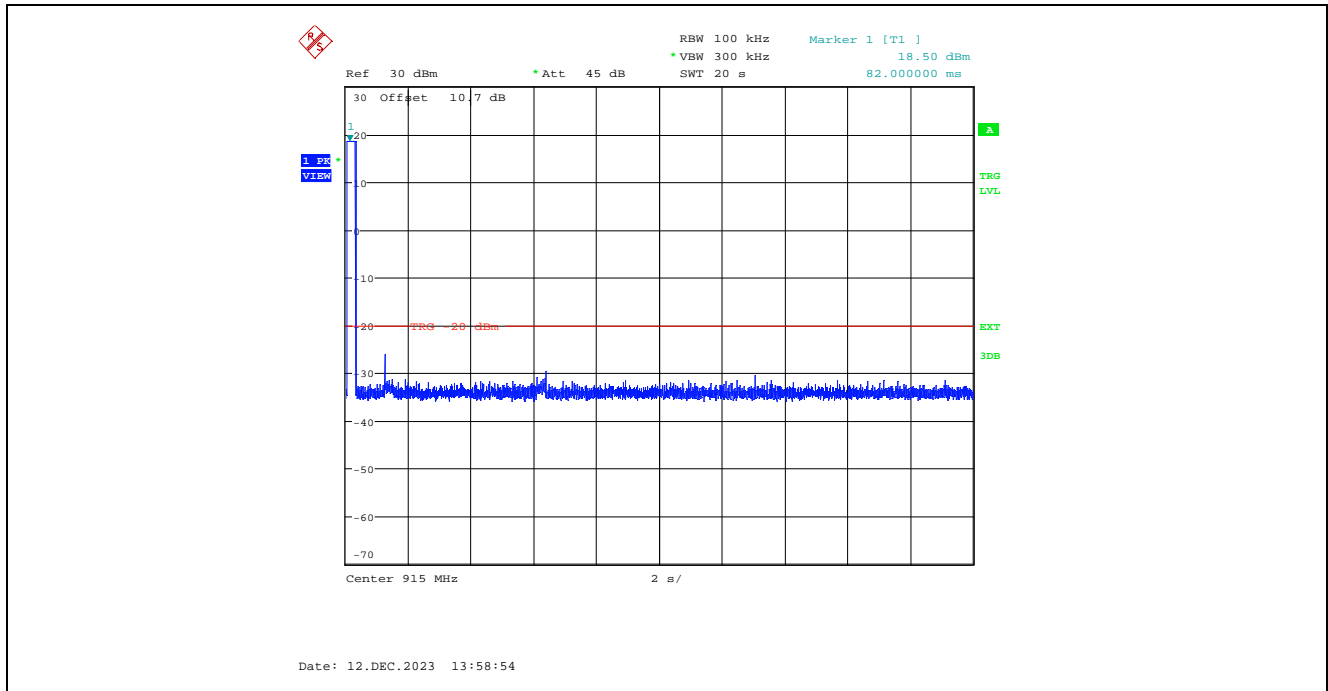

Plot 5.3.4.20. Time of Occupancy, 927 MHz, 10 kbps
 Dwell Time per hop at 927 MHz = 299.90 ms

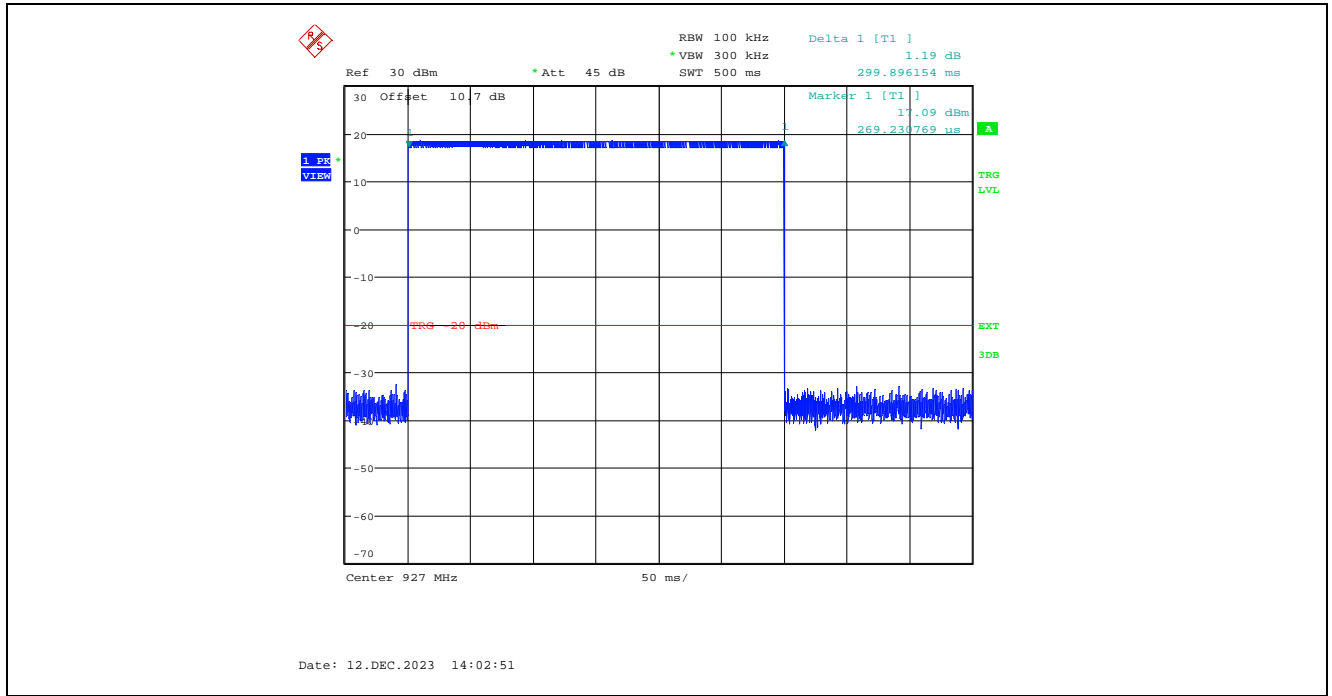

Plot 5.3.4.21. Time of Occupancy, 927 MHz, 10 kbps
 Average time of occupancy = (Dwell Time per hop) x (number of hops within a 20s period) = 299.90 ms x 1 = 299.90 ms

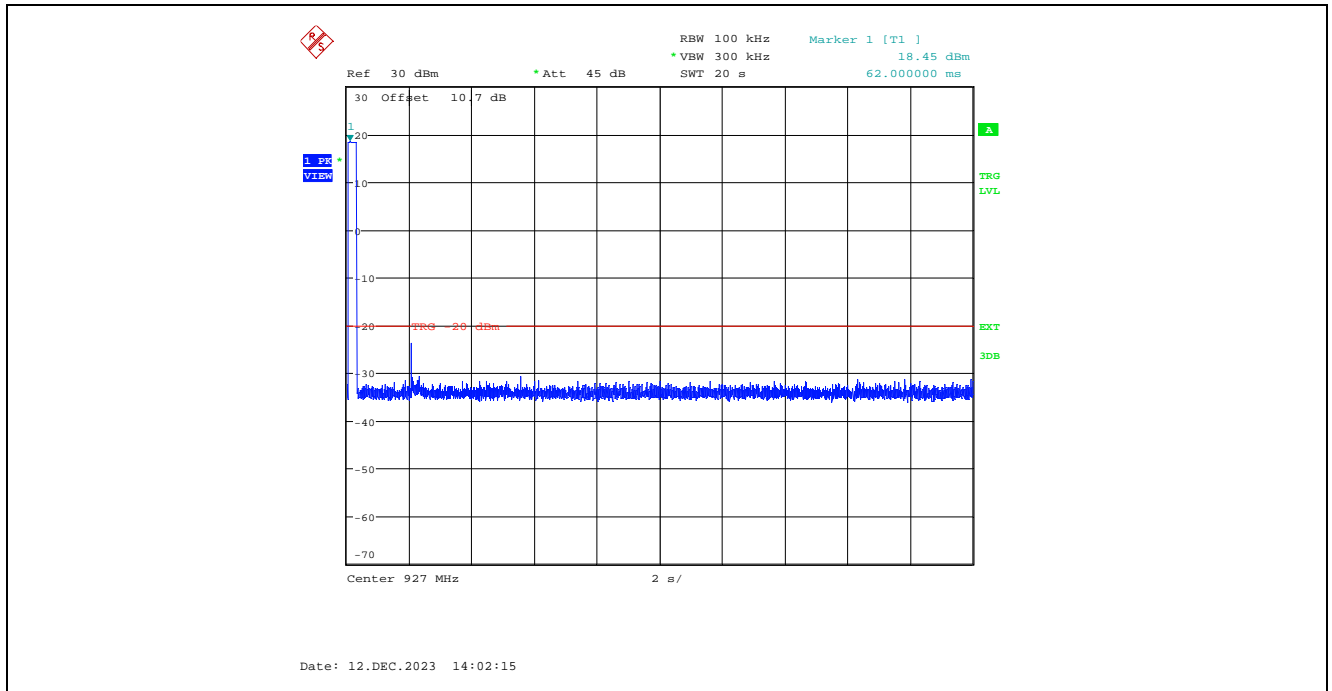

Plot 5.3.4.22. Time of Occupancy, 902.5 MHz, 110 kbps
Dwell Time per hop at 902.5 MHz = 29.86 ms

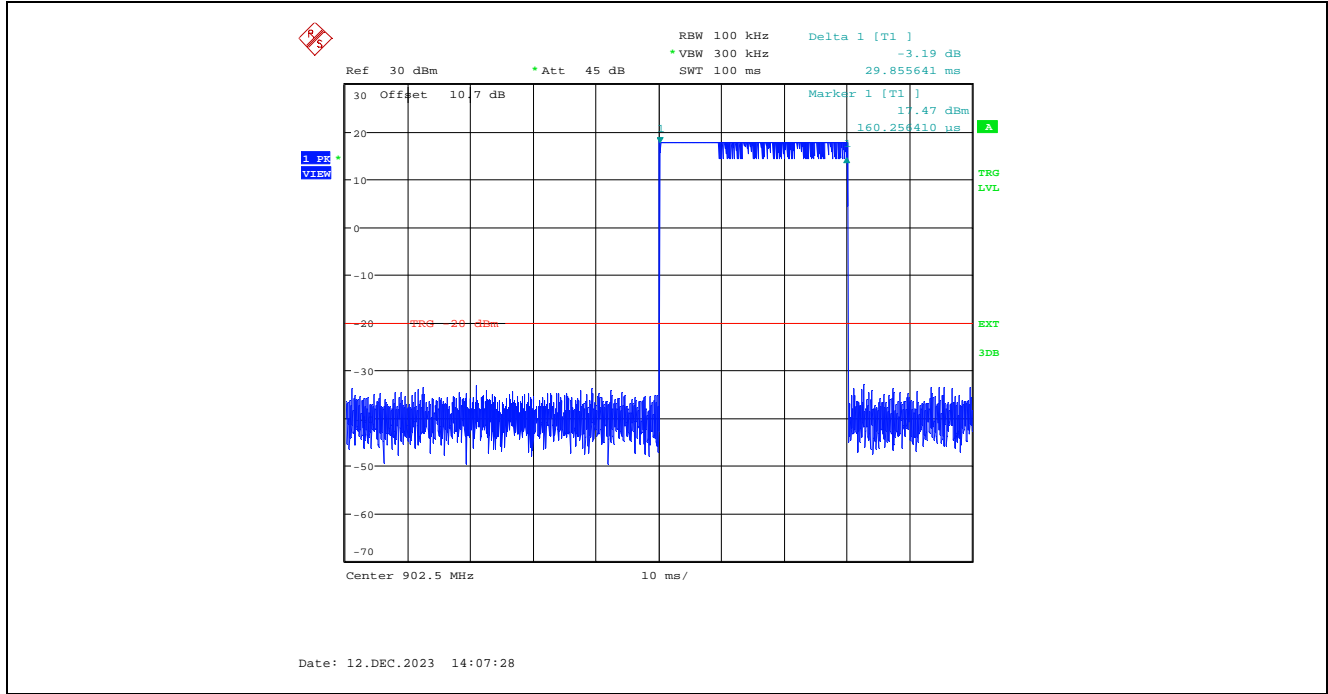

Plot 5.3.4.23. Time of Occupancy, 902.5 MHz, 110 kbps
Average time of occupancy = (Dwell Time per hop) x (number of hops within a 20s period) = 29.86 ms x 13 = 388.18 ms

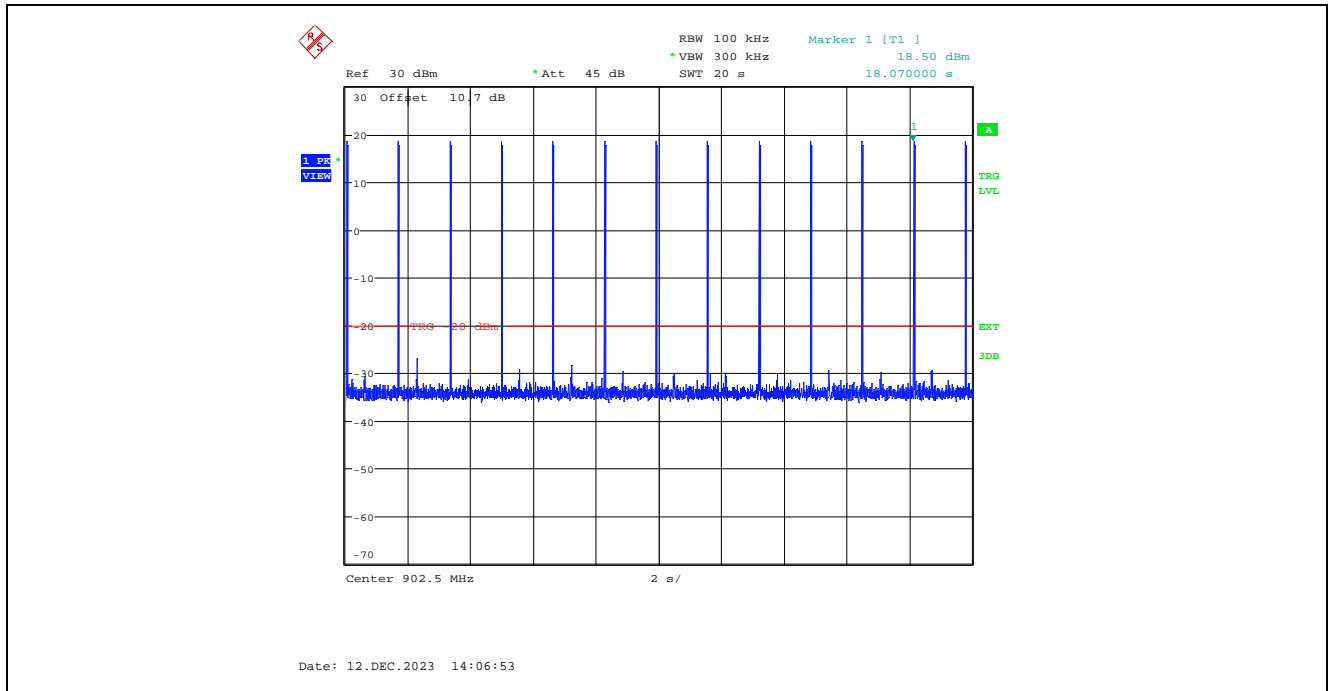

Plot 5.3.4.24. Time of Occupancy, 915 MHz, 110 kbps
Dwell Time per hop at 915 MHz = 30.02 ms

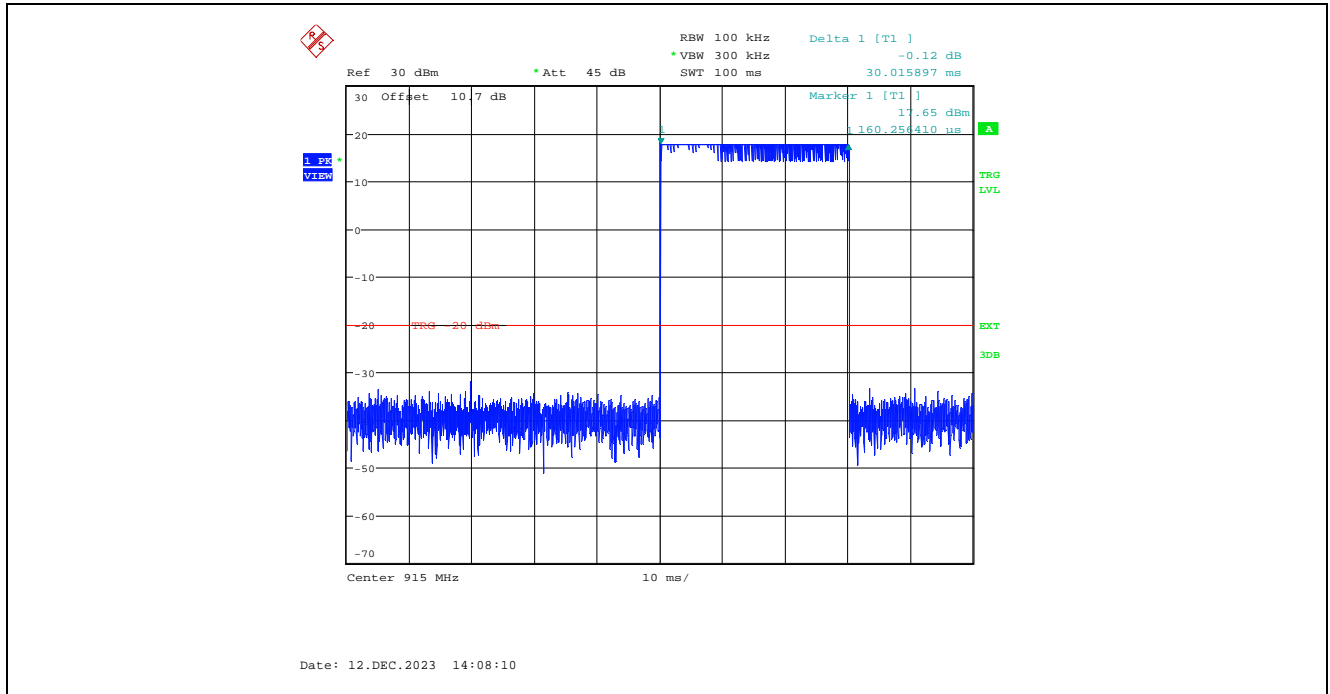

Plot 5.3.4.25. Time of Occupancy, 915 MHz, 110 kbps
Average time of occupancy = (Dwell Time per hop) x (number of hops within a 20s period) = 30.02 ms x 13 = 390.26 ms

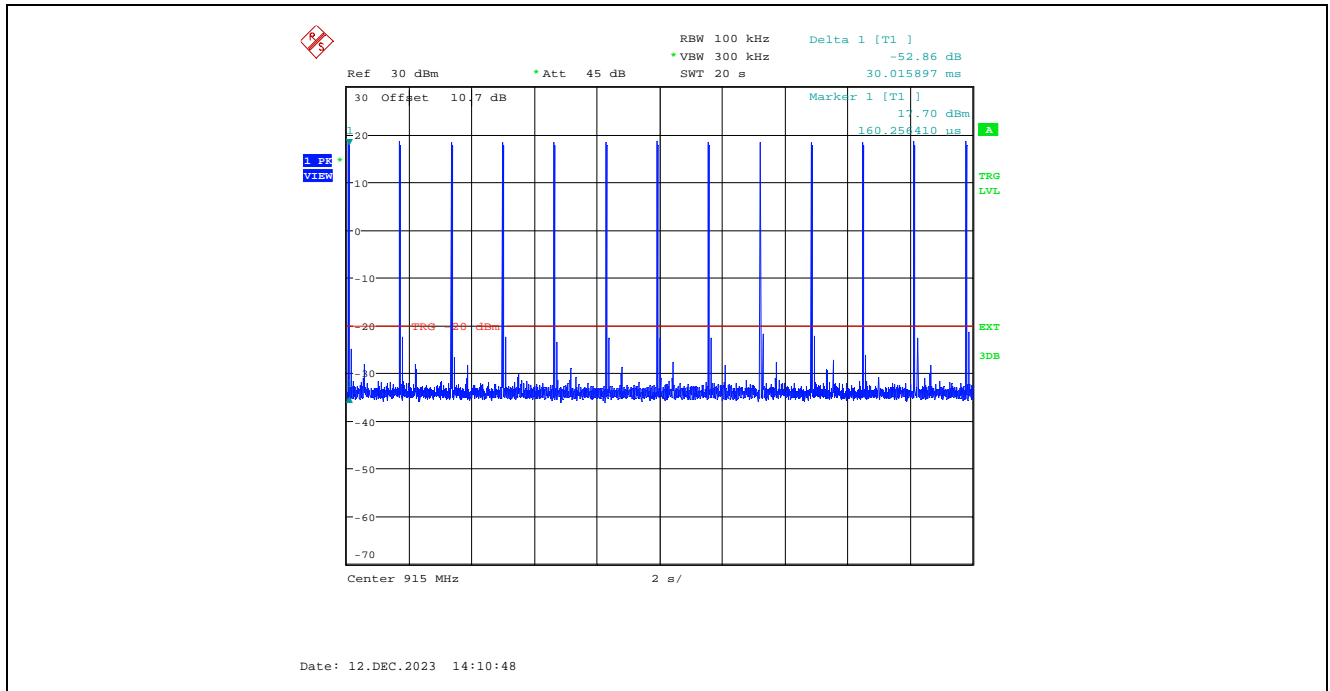

Plot 5.3.4.26. Time of Occupancy, 927 MHz, 110 kbps
 Dwell Time per hop at 927 MHz = 29.88 ms

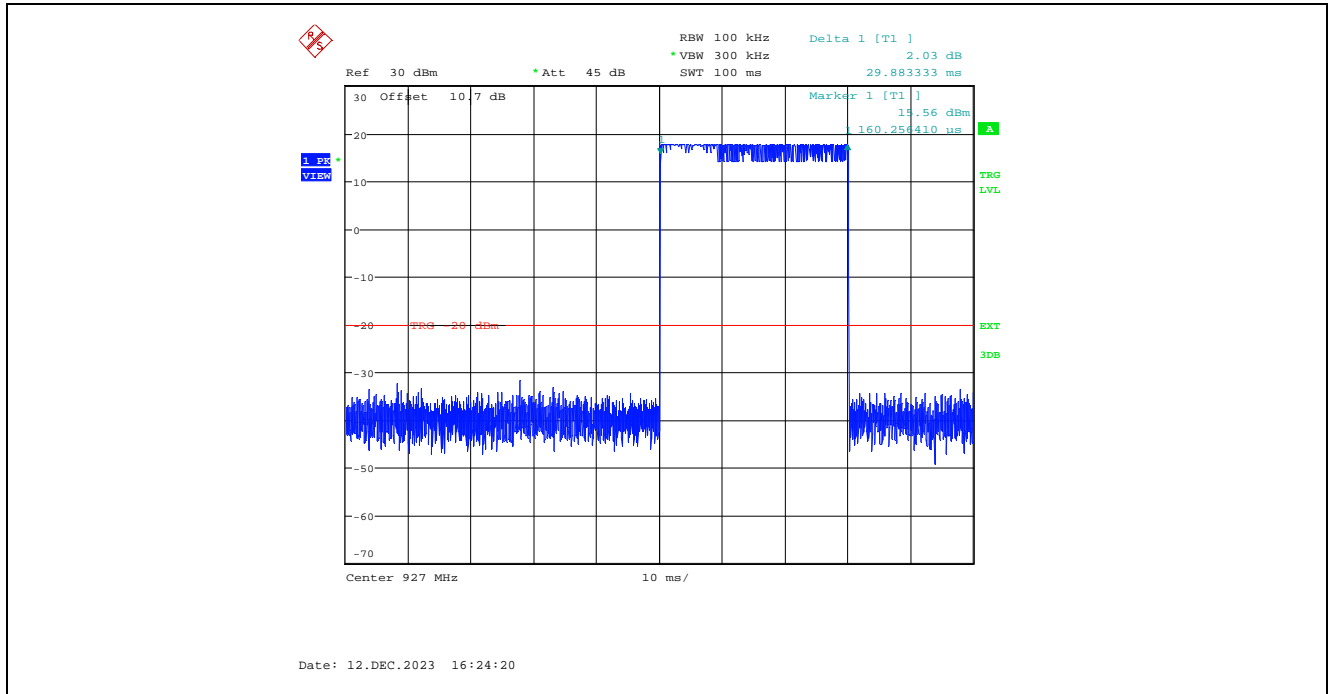

Plot 5.3.4.27. Time of Occupancy, 927 MHz, 110 kbps
 Average time of occupancy = (Dwell Time per hop) x (number of hops within a 20s period) = 29.88 ms x 13 = 388.44 ms

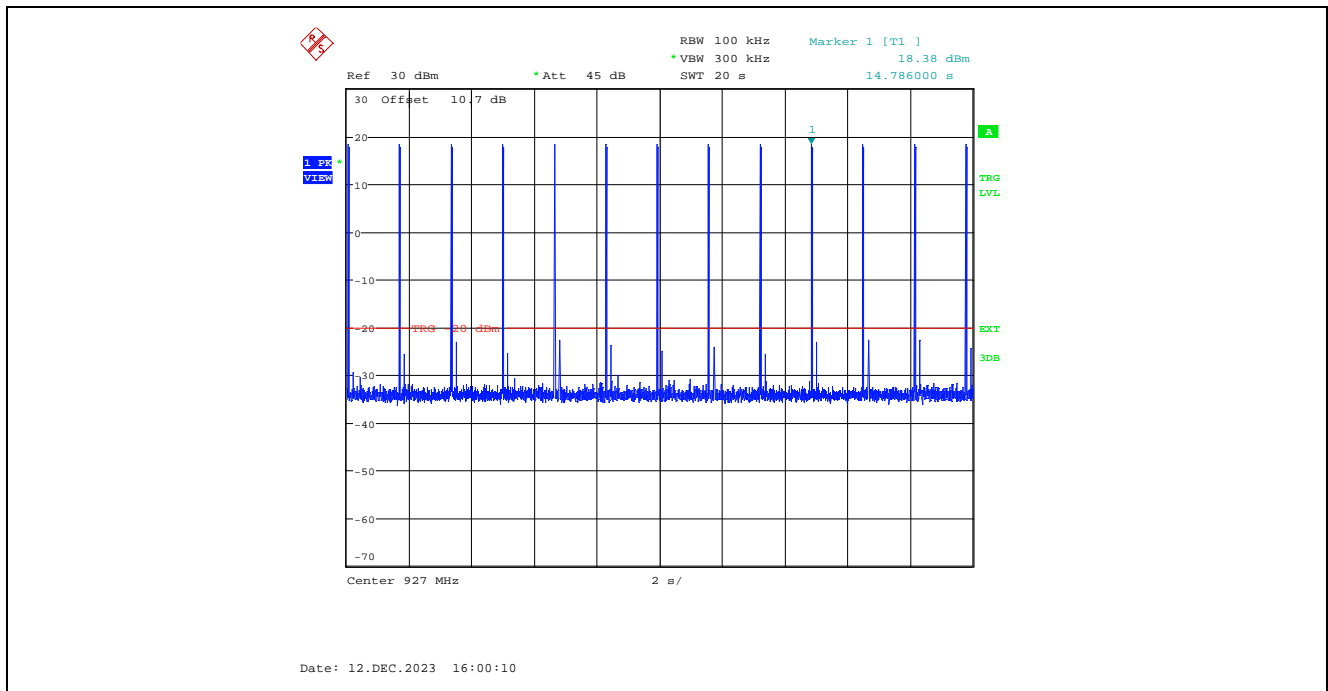

Plot 5.3.4.28. Time of Occupancy, 902.75 MHz, 250 kbps
Dwell Time per hop at 902.75 MHz = 15.31 ms

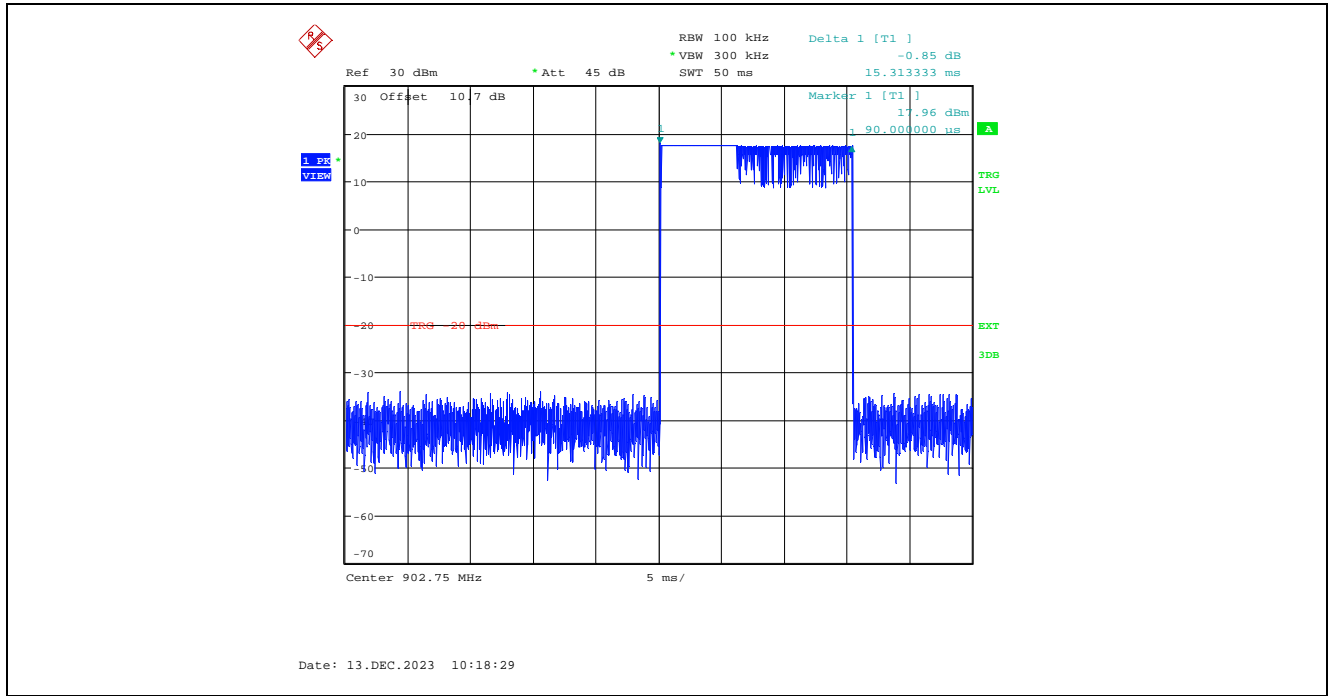

Plot 5.3.4.29. Time of Occupancy, 902.75 MHz, 250 kbps
Average time of occupancy = (Dwell Time per hop) x (number of hops within a 10s period) = 15.31 ms x 11 = 168.41 ms

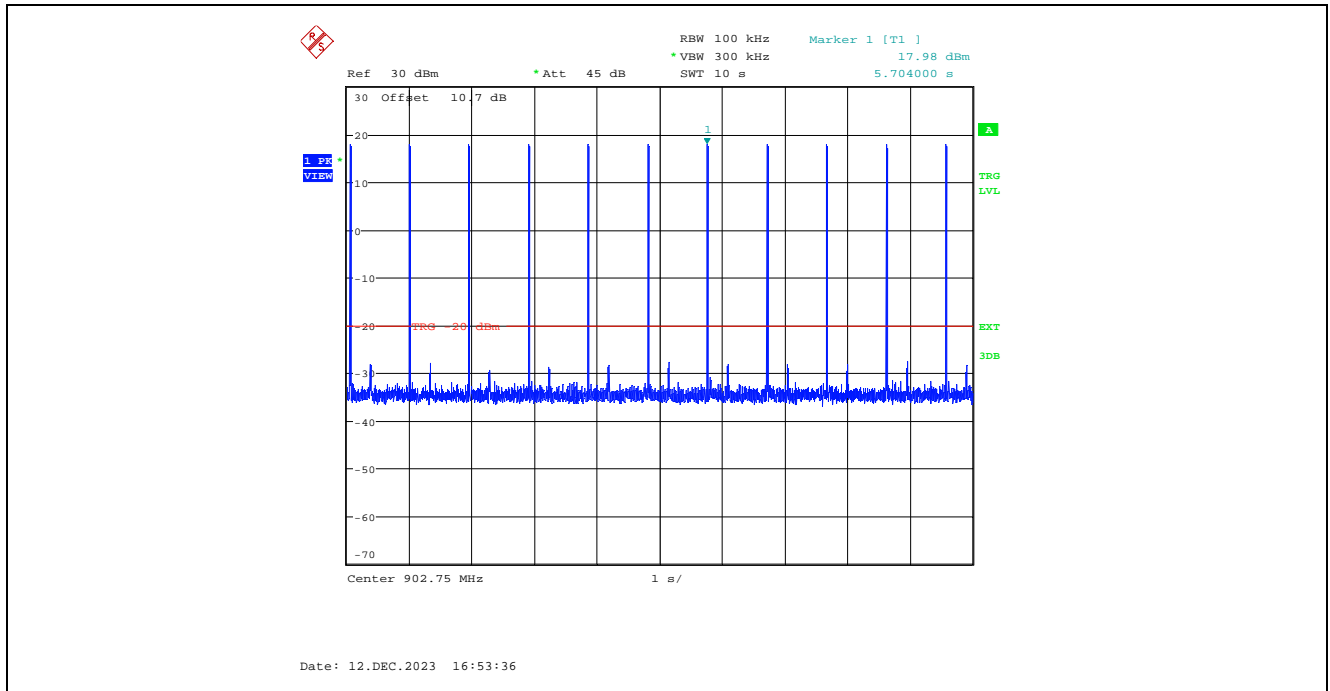

Plot 5.3.4.30. Time of Occupancy, 915.25 MHz, 250 kbps
Dwell Time per hop at 915.25 MHz = 15.32 ms

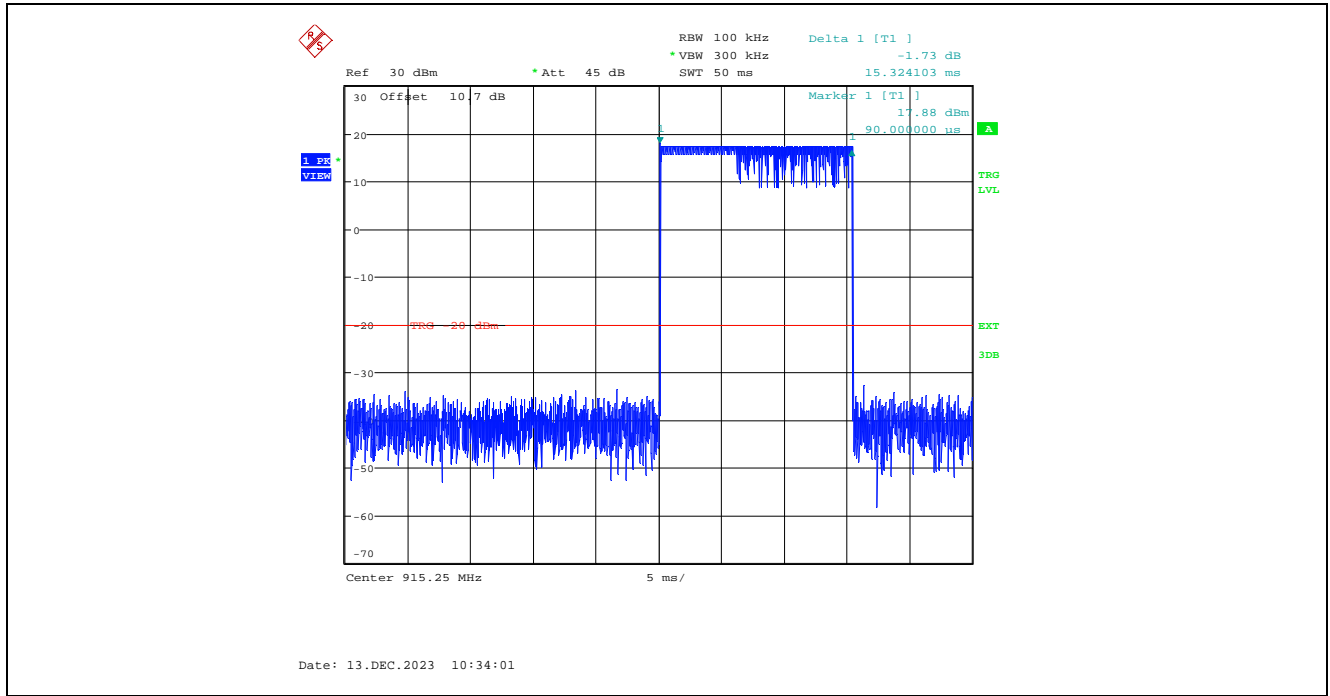

Plot 5.3.4.31. Time of Occupancy, 915.25 MHz, 250 kbps
Average time of occupancy = (Dwell Time per hop) x (number of hops within a 10s period) = 15.32 ms x 11 = 168.52 ms

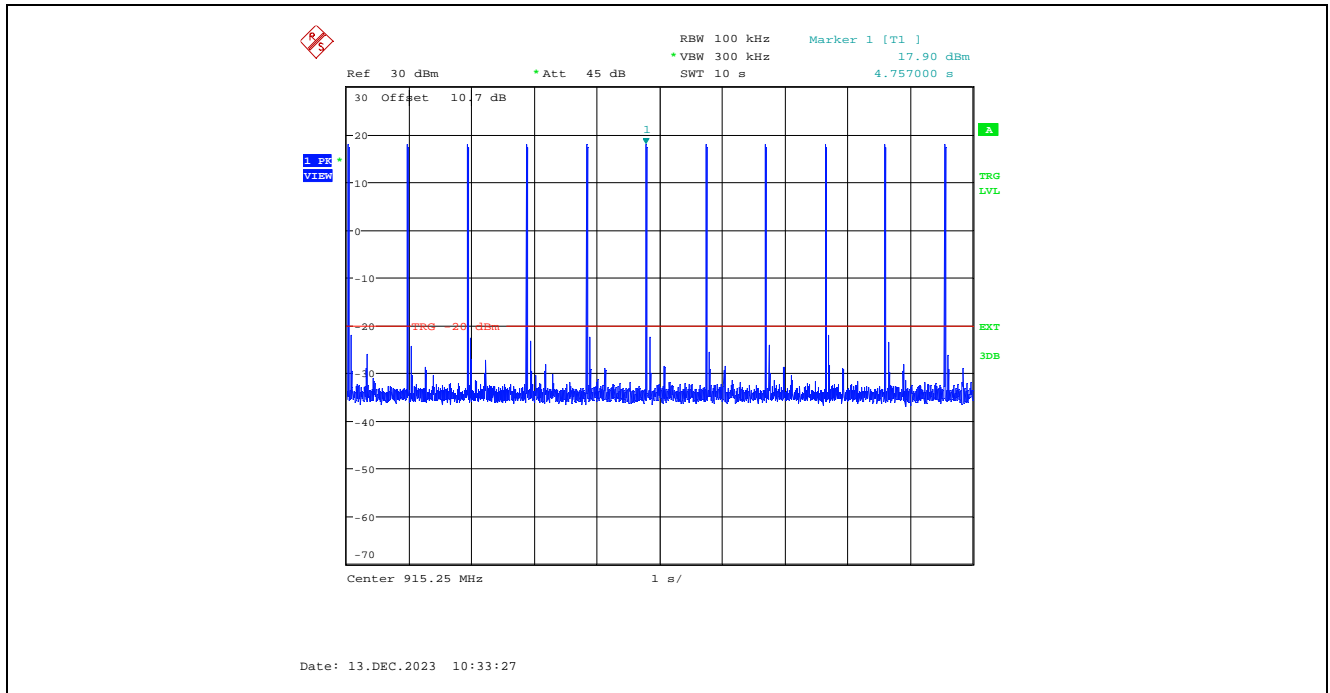

Plot 5.3.4.32. Time of Occupancy, 927.25 MHz, 250 kbps
Dwell Time per hop at 927.25 MHz = 15.38 ms

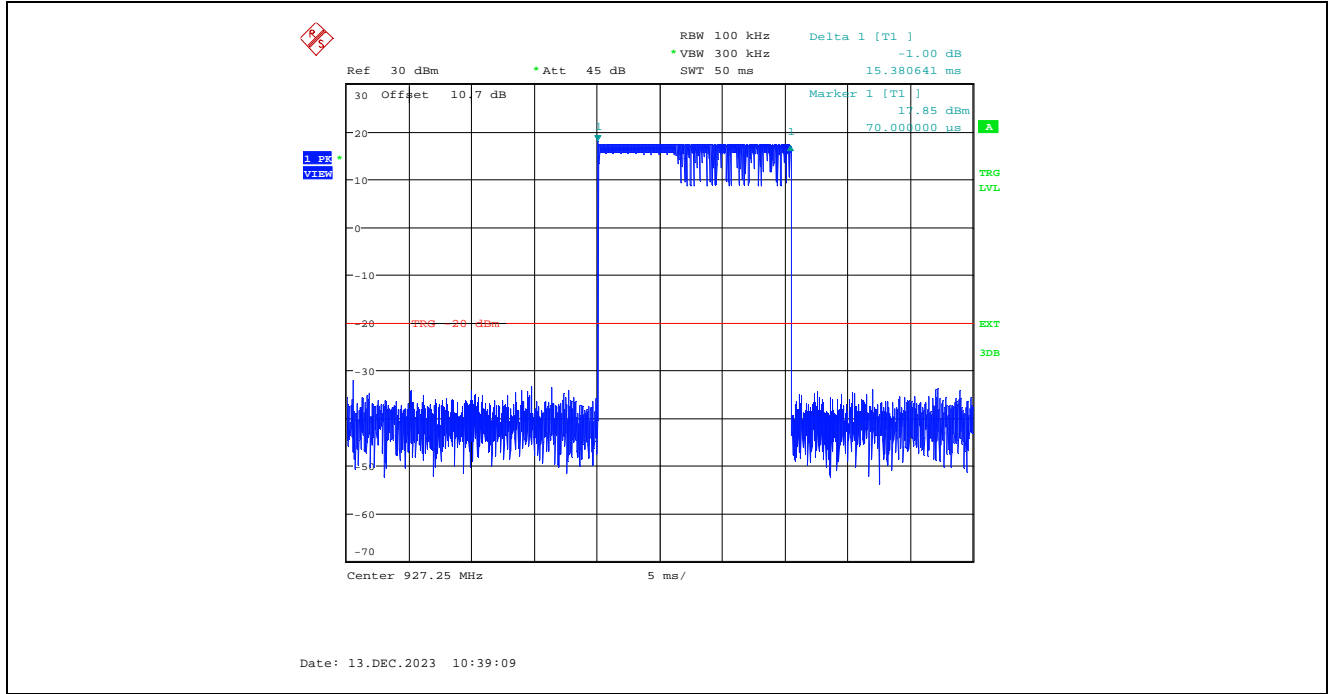

Plot 5.3.4.33. Time of Occupancy, 927.25 MHz, 250 kbps
Average time of occupancy = (Dwell Time per hop) x (number of hops within a 10s period) = 15.38 ms x 11 = 169.18 ms

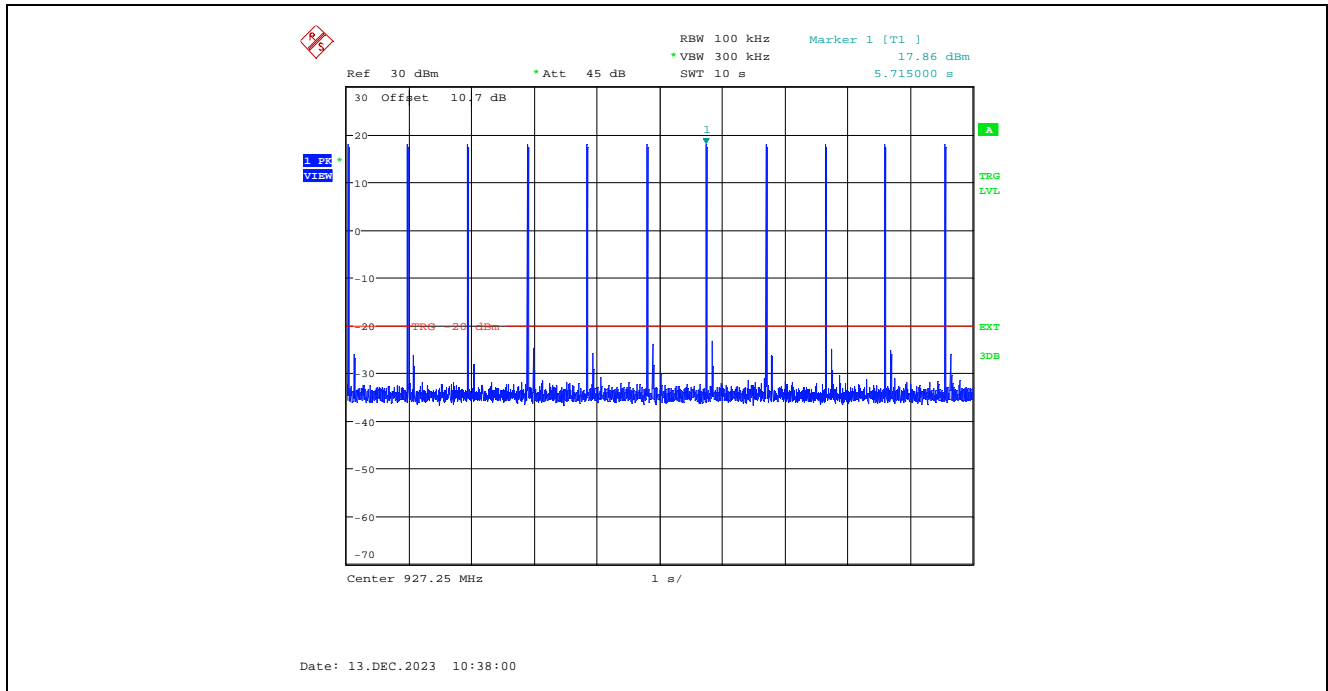

5.4. PEAK CONDUCTED OUTPUT POWER [§ 15.247(b)(2)]

5.4.1. Limits

§15.247(b)(2): For frequency hopping systems operating in the 902-928 MHz band: 1 watt for systems employing at least 50 hopping channels; and, 0.25 watts for systems employing less than 50 hopping channels, but at least 25 hopping channels, as permitted under [paragraph \(a\)\(1\)\(i\)](#) of this section.

§15.247(b)(4): The conducted output power limit specified in [paragraph \(b\)](#) of this section is based on the use of antennas with directional gains that do not exceed 6 dBi. Except as shown in [paragraph \(c\)](#) of this section, if transmitting antennas of directional gain greater than 6 dBi are used, the conducted output power from the intentional radiator shall be reduced below the stated values in [paragraphs \(b\)\(1\), \(b\)\(2\), and \(b\)\(3\)](#) of this section, as appropriate, by the amount in dB that the directional gain of the antenna exceeds 6 dBi.

5.4.2. Method of Measurements

ANSI C63.10-2020, section 7.8.5

5.4.3. Test Arrangement

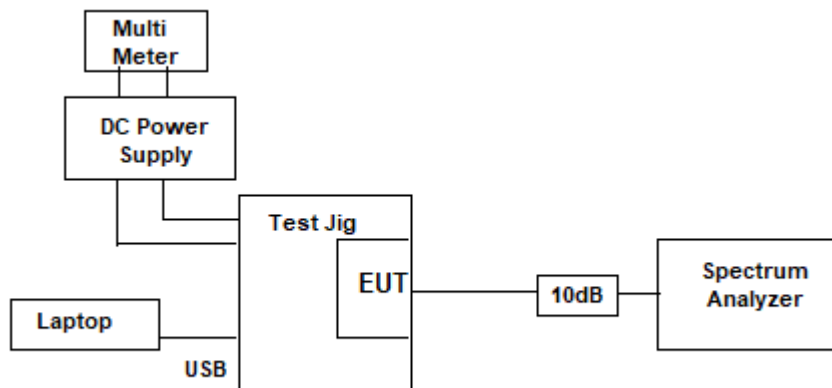

5.4.4. Test Data

5.4.4.1. XB-9XR-DMUM-001 Maximum Peak Conducted Output Power and EIRP

XB-9XR-DMUM-001 Maximum Peak Conducted Output Power

Power Setting (High/Low)	Data Rate (kbps)	Frequency (MHz)	Maximum Peak Conducted Output Power		Peak Conducted Output Power Limit (dBm)
			(dBm)	(W)	
High	10	902.5	18.91	0.07780	30
		915	18.81	0.07603	30
		927	18.77	0.07534	30
	110	902.5	18.89	0.07745	30
		915	18.81	0.07603	30
		927	18.75	0.07499	30
	250	902.75	18.88	0.07727	30
		915.25	18.81	0.07603	30
		927.25	18.77	0.07534	30
Low	10	902.5	0.27	0.00106	30
		915	0.17	0.00104	30
		927	0.11	0.00103	30
	110	902.5	0.23	0.00105	30
		915	0.14	0.00103	30
		927	0.08	0.00102	30
	250	902.75	0.20	0.00105	30
		915.25	0.11	0.00103	30
		927.25	0.07	0.00102	30

XB-9XR-DMUM-001 Power Level, Antenna Details and Resulting EIRP Values

Maximum Peak Conducted Output Power: 18.91 dBm					
Assembly #	Antenna Type	Maximum Gain (dBi)	Minimum Insertion / Cable Loss (dBm)	Antenna Assembly Gain (dBm)	EIRP (dBm)
1	Flat Antenna	2	0	2	20.91
2	Dipole Antenna	2.96	0.3	2.66	21.57
3	Omni Directional Antenna	8.0	0.62	7.38	26.29
4	Yagi Antenna	15.1	0.62	14.48	33.39
5	Flex Antenna	1	0	1	19.91
6	Phantom (Dome) Antenna	3	0.62	2.38	21.29
7	Ceramic Chip Antenna	0.8	0	0.8	19.71

Refer to the following for test data plots.

Plot 5.4.4.1.1. XB-9XR-DMUM-001 Maximum Peak Conducted Output Power, High Power Setting, 10 kbps, 902.5 MHz

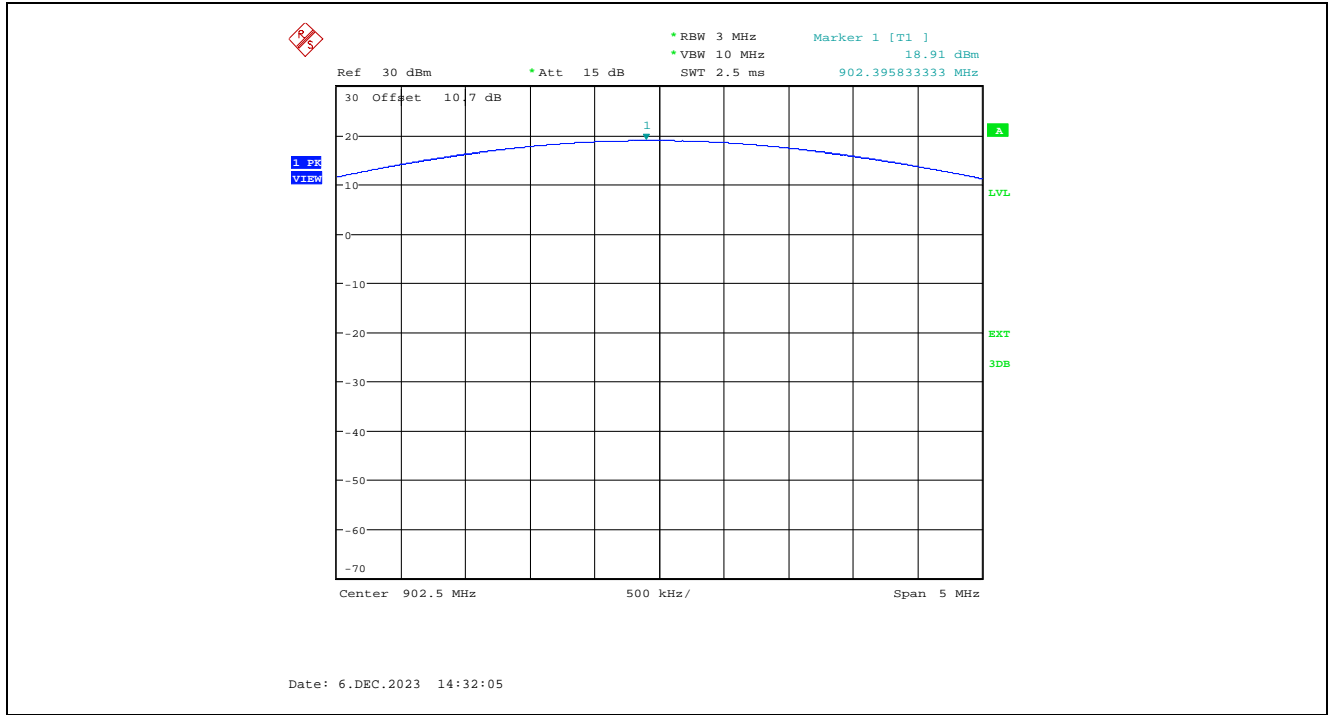

Plot 5.4.4.1.2. XB-9XR-DMUM-001 Maximum Peak Conducted Output Power, High Power Setting, 10 kbps, 915 MHz

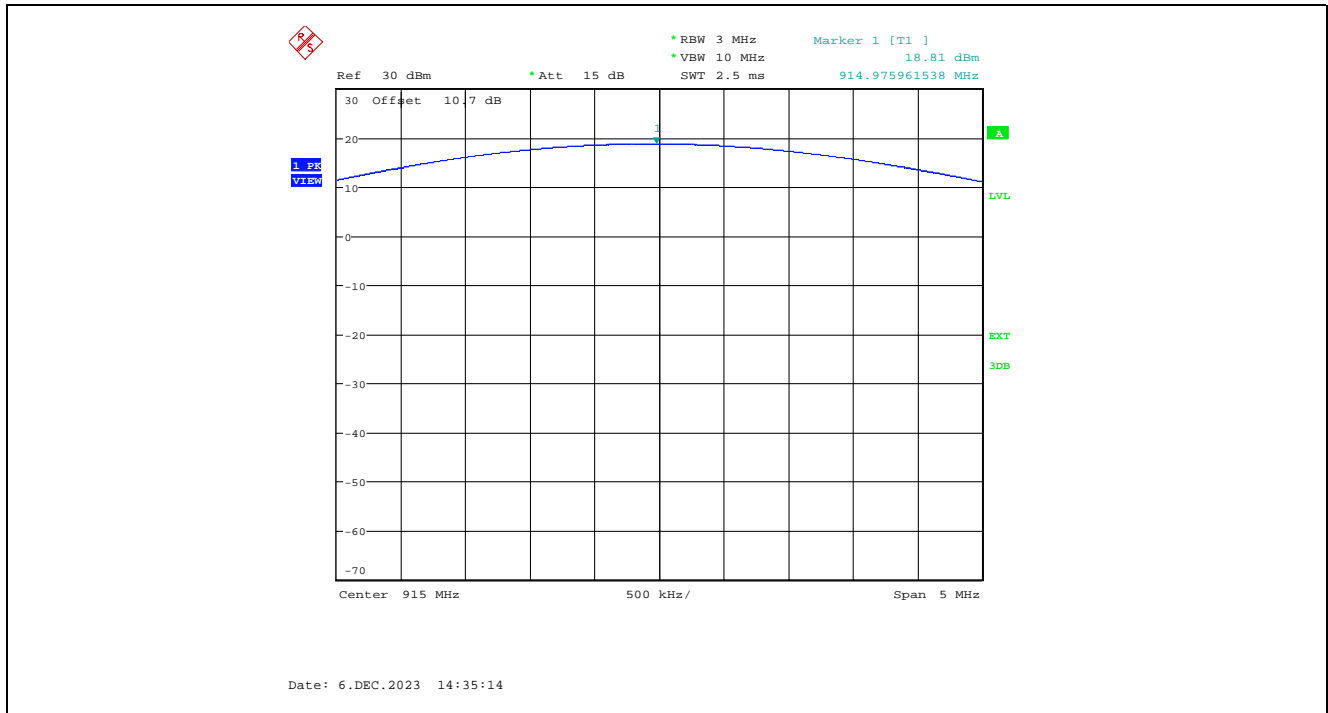

Plot 5.4.4.1.3. XB-9XR-DMUM-001 Maximum Peak Conducted Output Power, High Power Setting, 10 kbps, 927 MHz

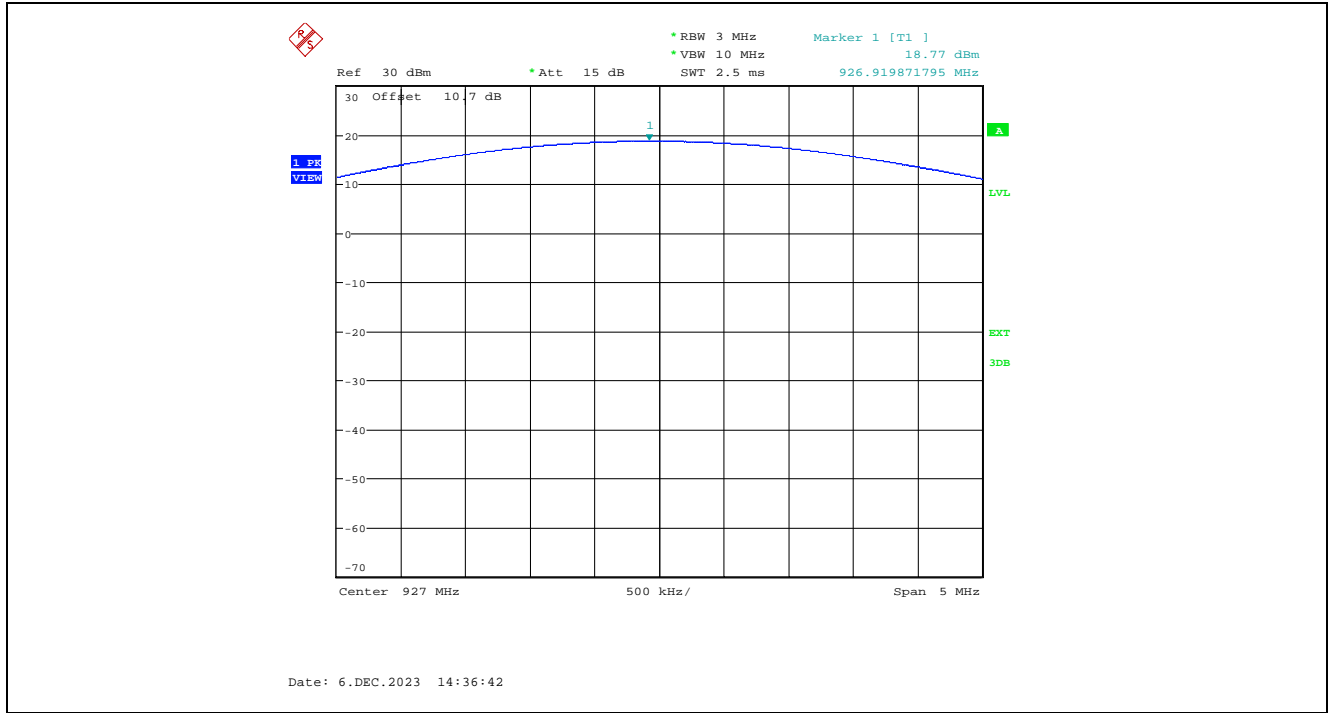

Plot 5.4.4.1.4. XB-9XR-DMUM-001 Maximum Peak Conducted Output Power, High Power Setting, 110 kbps, 902.5 MHz

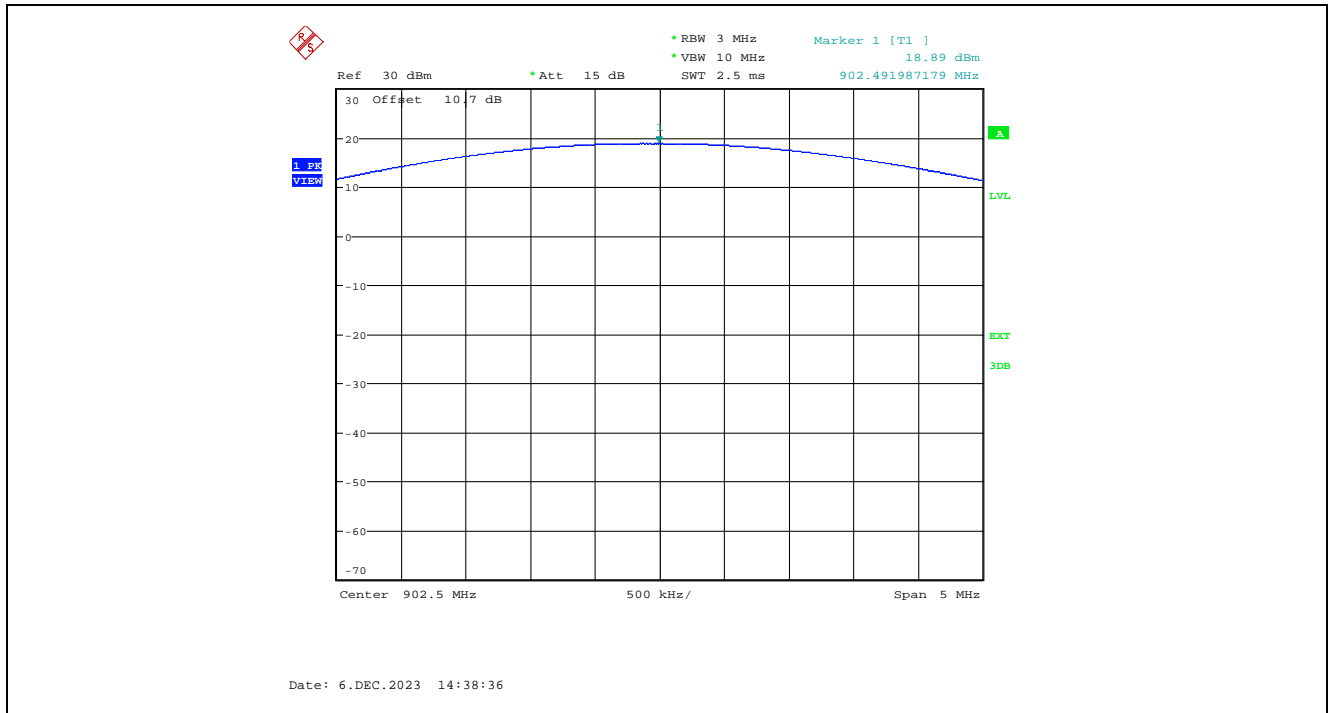

Plot 5.4.4.1.5. XB-9XR-DMUM-001 Maximum Peak Conducted Output Power, High Power Setting, 110 kbps, 915 MHz

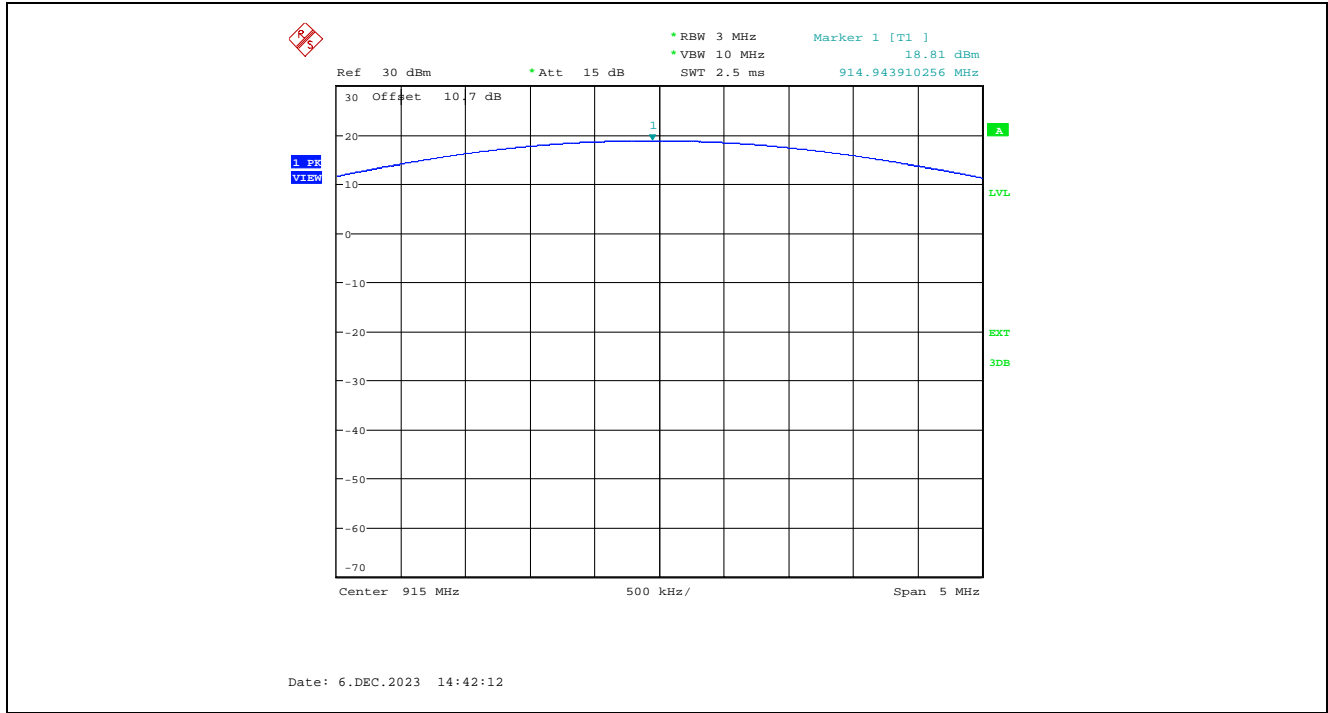

Plot 5.4.4.1.6. XB-9XR-DMUM-001 Maximum Peak Conducted Output Power, High Power Setting, 110 kbps, 927 MHz

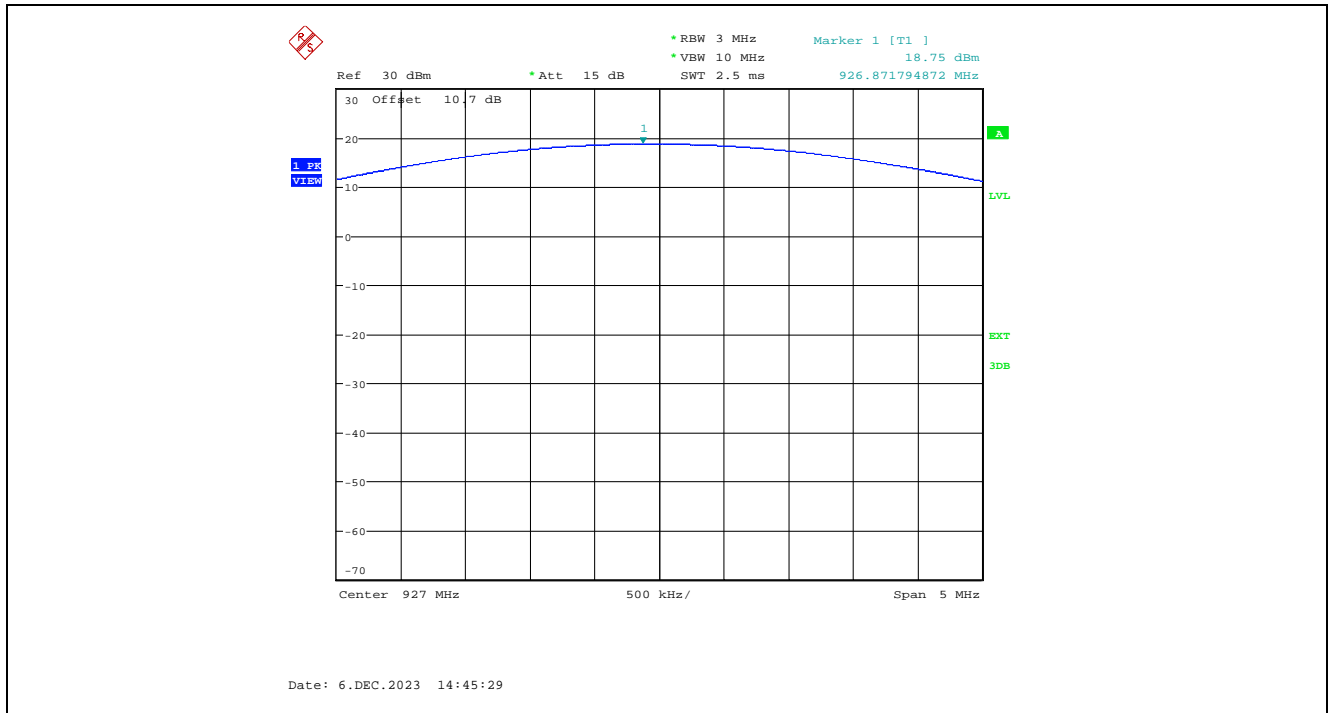

Plot 5.4.4.1.7. XB-9XR-DMUM-001 Maximum Peak Conducted Output Power, High Power Setting, 250 kbps, 902.75 MHz

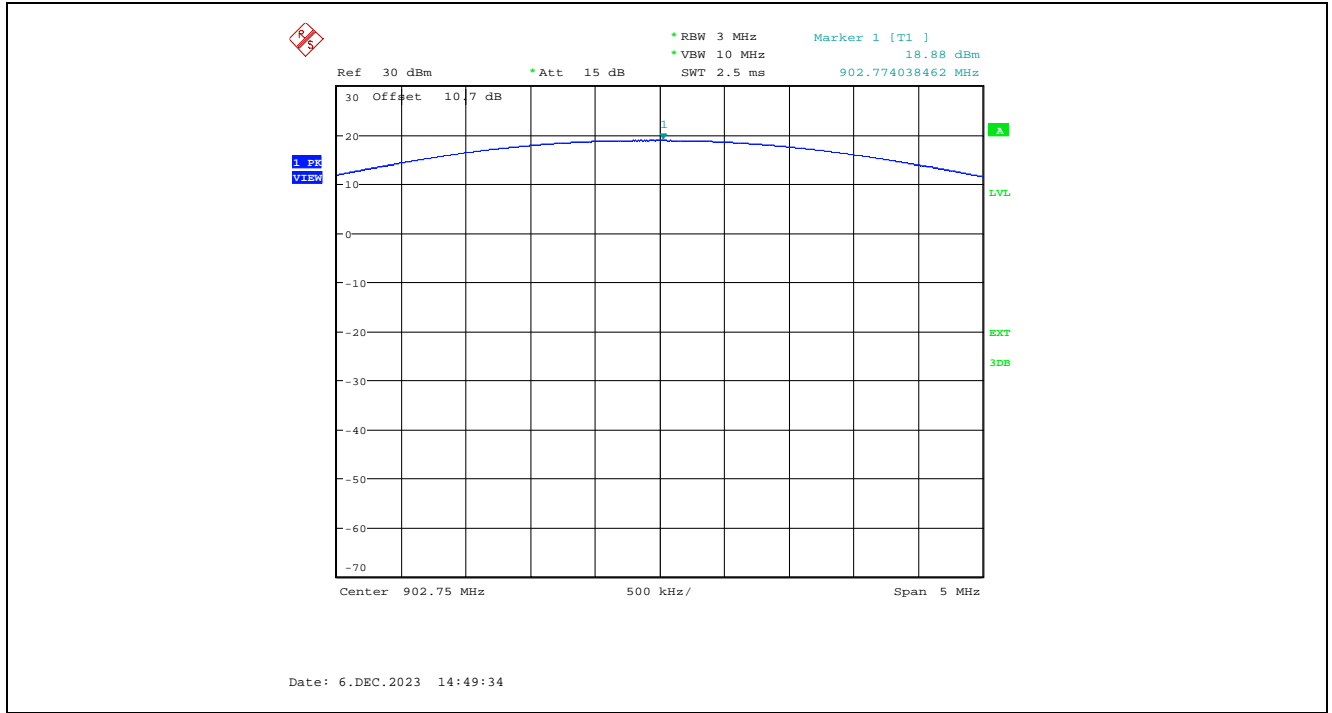

Plot 5.4.4.1.8. XB-9XR-DMUM-001 Maximum Peak Conducted Output Power, High Power Setting, 250 kbps, 915.25 MHz

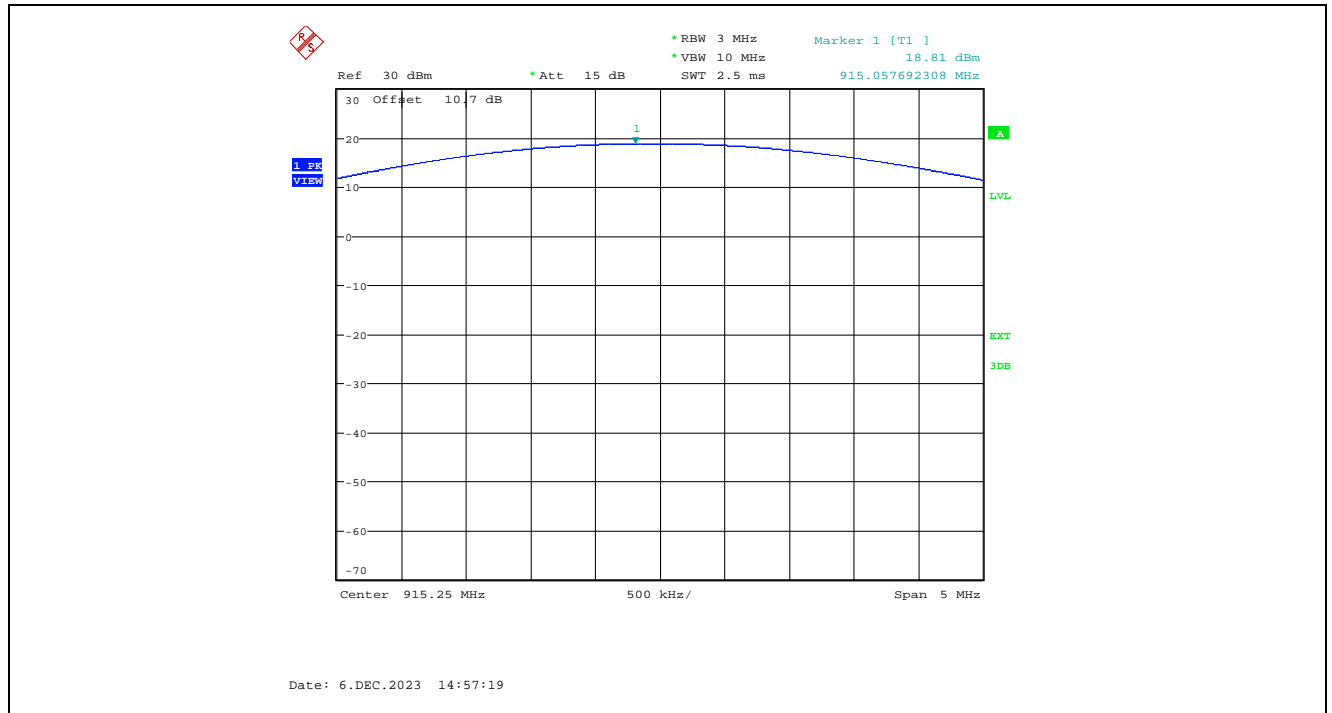

Plot 5.4.4.1.9. XB-9XR-DMUM-001 Maximum Peak Conducted Output Power, High Power Setting, 250 kbps, 927.25 MHz

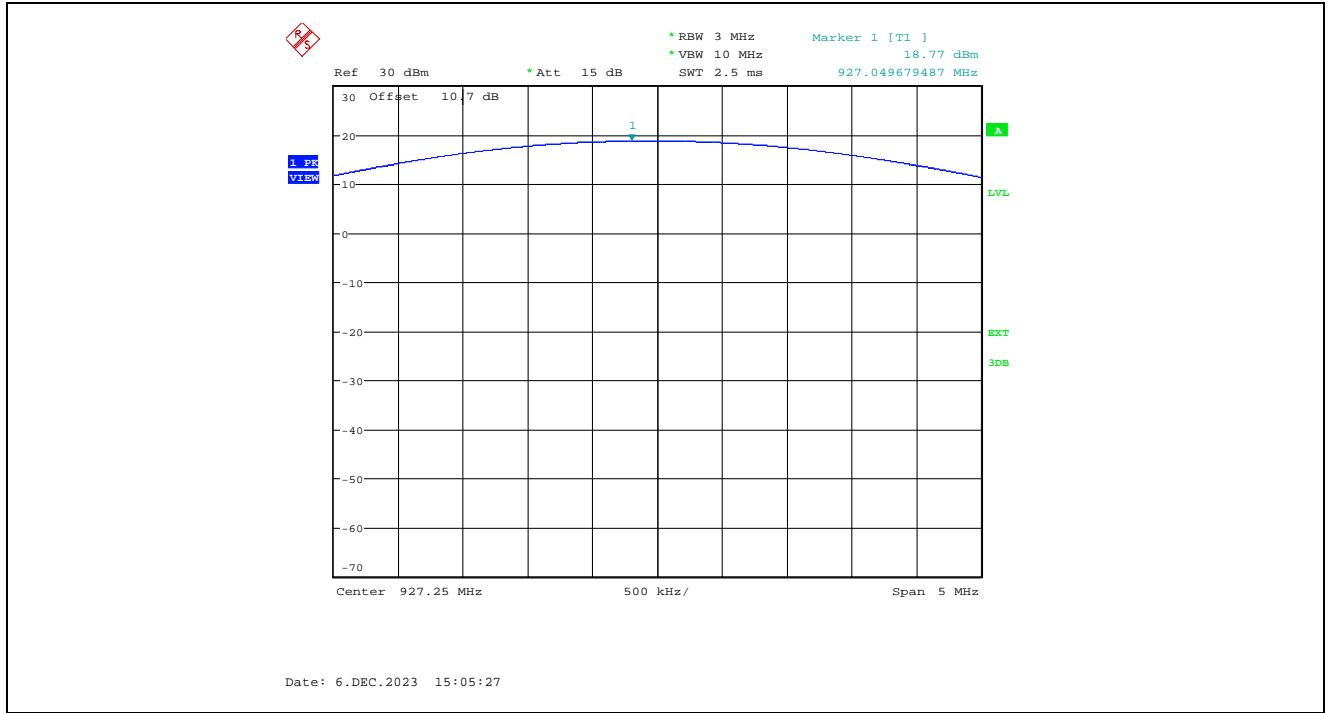

Plot 5.4.4.1.10. XB-9XR-DMUM-001 Maximum Peak Conducted Output Power, Low Power Setting, 10 kbps, 902.5 MHz

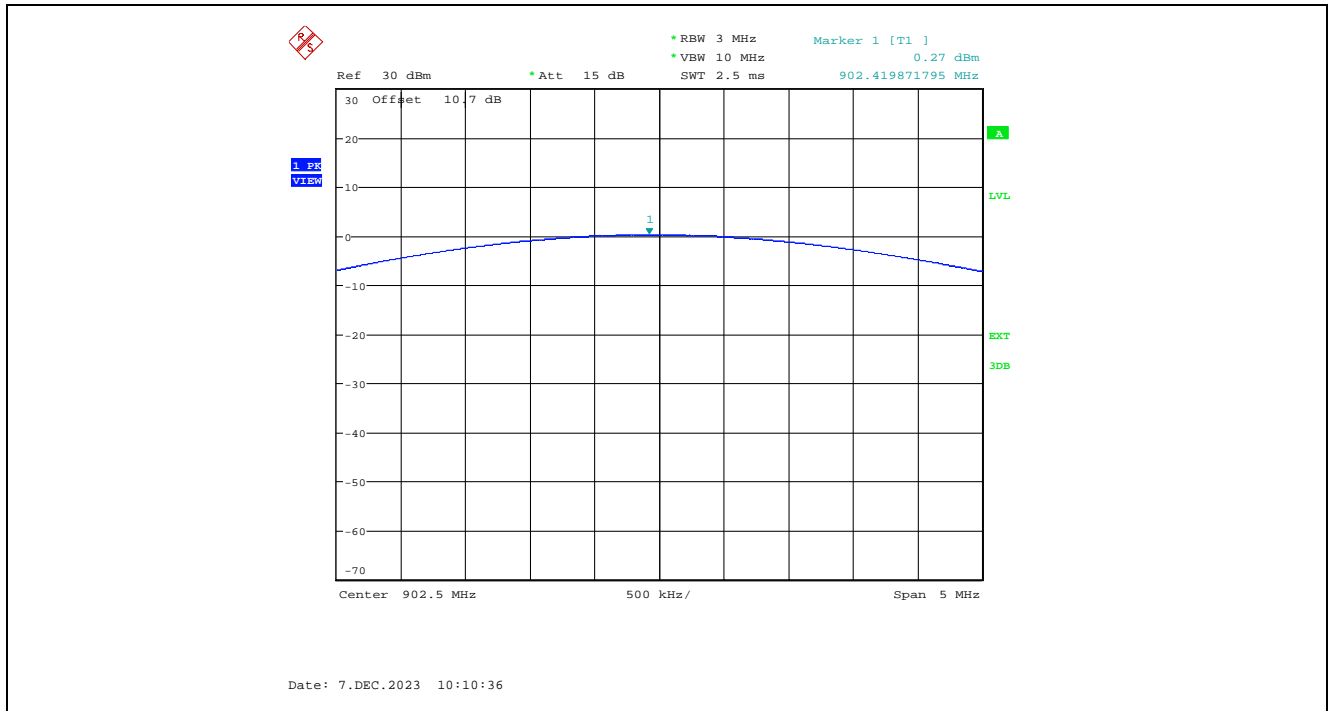

Plot 5.4.4.1.11. XB-9XR-DMUM-001 Maximum Peak Conducted Output Power, Low Power Setting, 10 kbps, 915 MHz

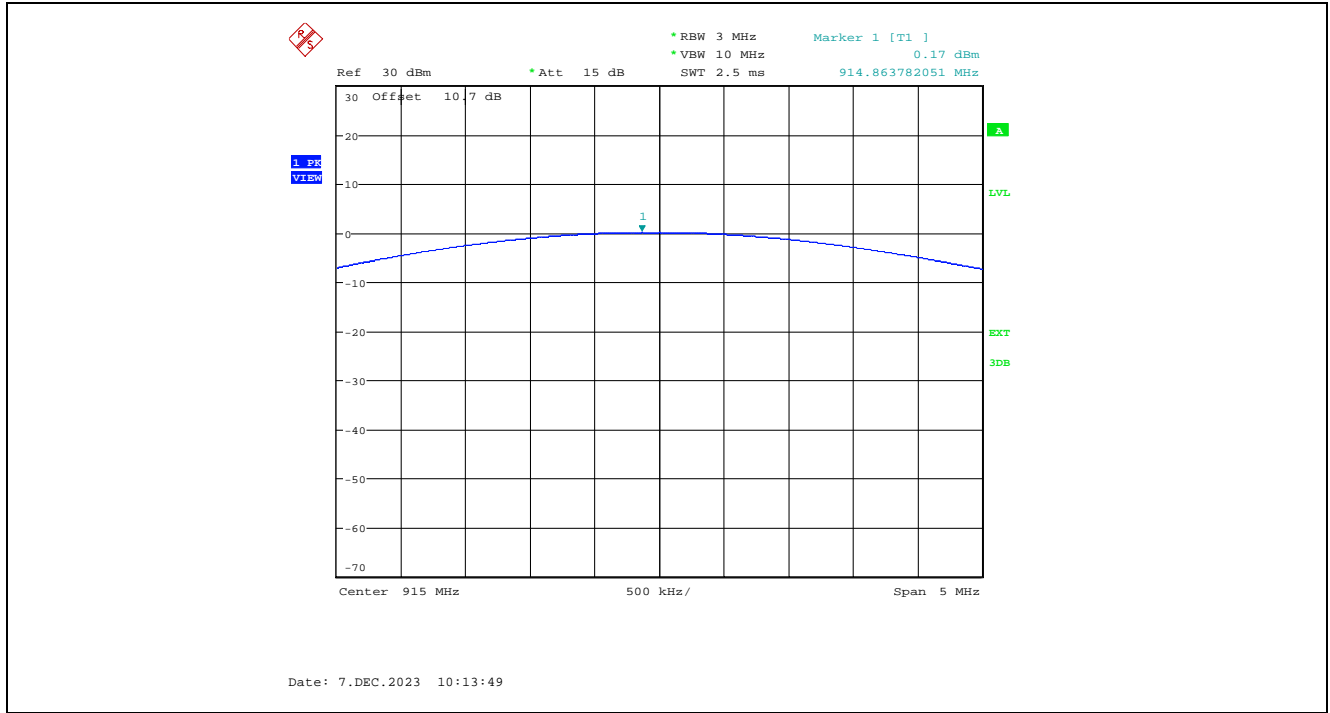

Plot 5.4.4.1.12. XB-9XR-DMUM-001 Maximum Peak Conducted Output Power, Low Power Setting, 10 kbps, 927 MHz

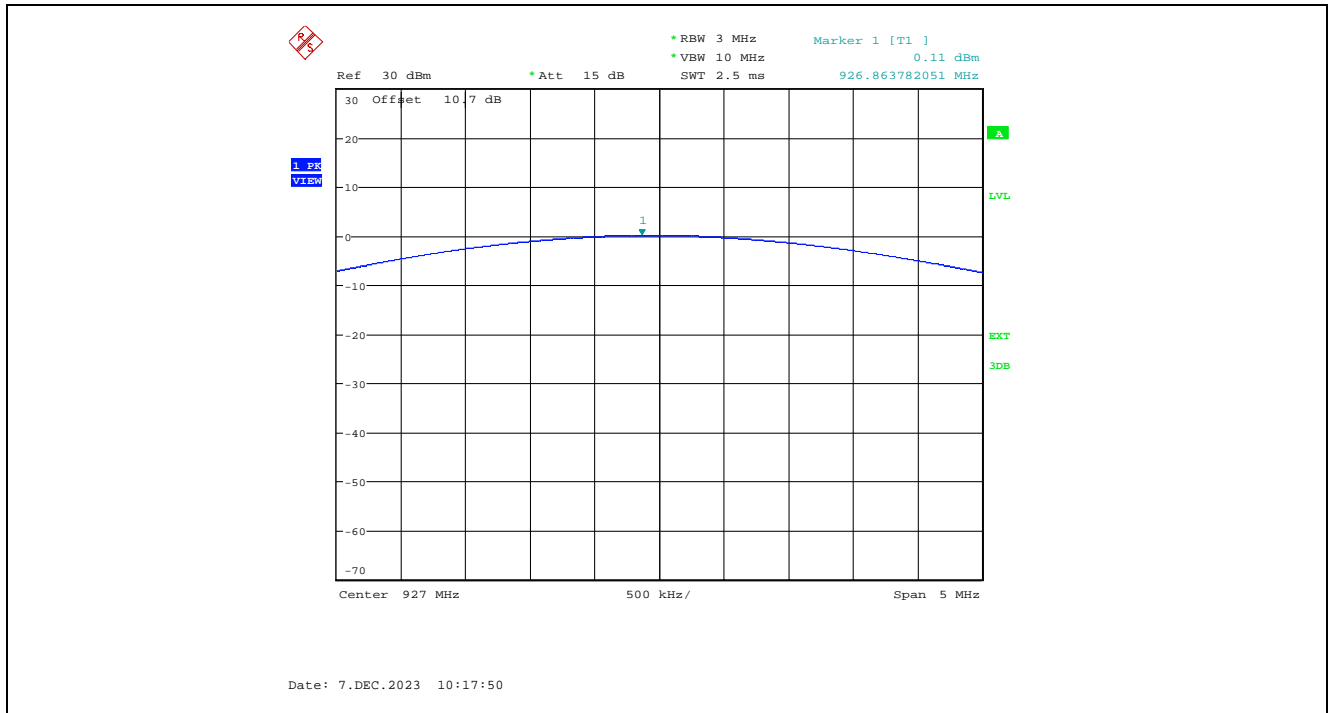

Plot 5.4.4.1.13. XB-9XR-DMUM-001 Maximum Peak Conducted Output Power, Low Power Setting, 110 kbps, 902.5 MHz

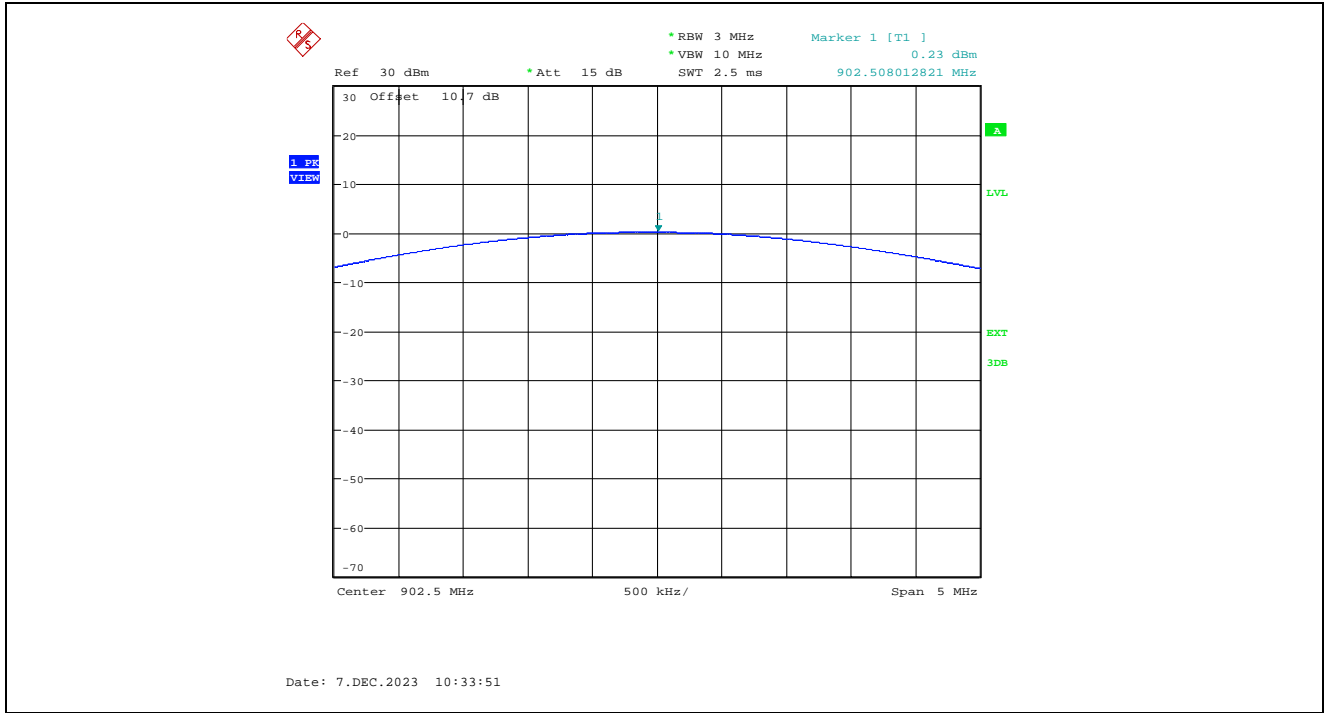

Plot 5.4.4.1.14. XB-9XR-DMUM-001 Maximum Peak Conducted Output Power, Low Power Setting, 110 kbps, 915 MHz

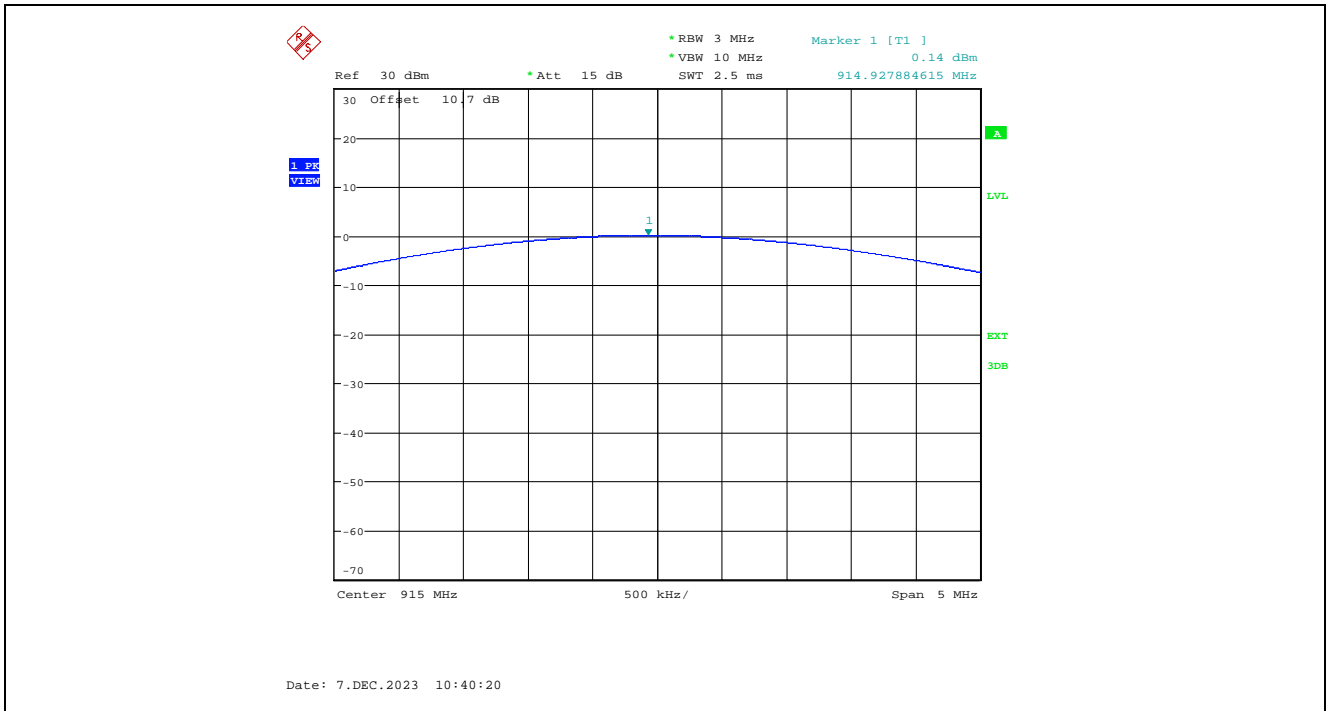

Plot 5.4.4.1.15. XB-9XR-DMUM-001 Maximum Peak Conducted Output Power, Low Power Setting, 110 kbps, 927 MHz

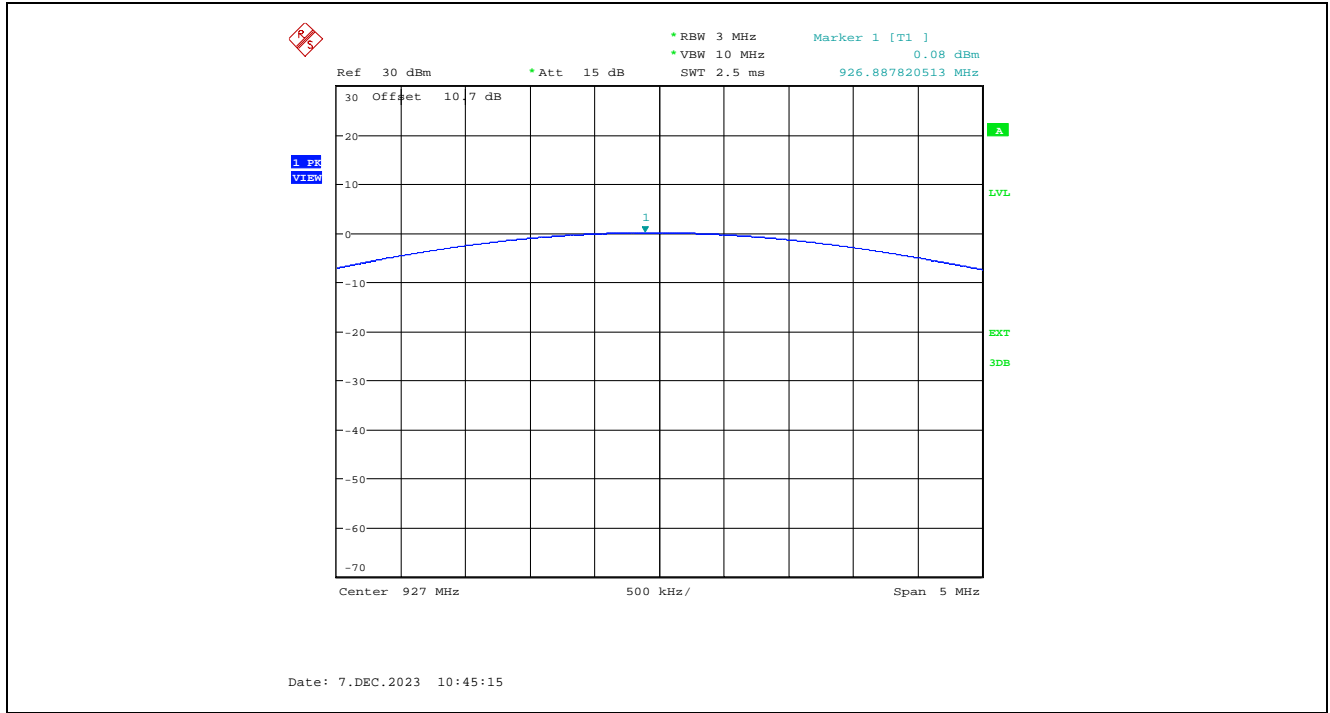

Plot 5.4.4.1.16. XB-9XR-DMUM-001 Maximum Peak Conducted Output Power, Low Power Setting, 250 kbps, 902.75 MHz

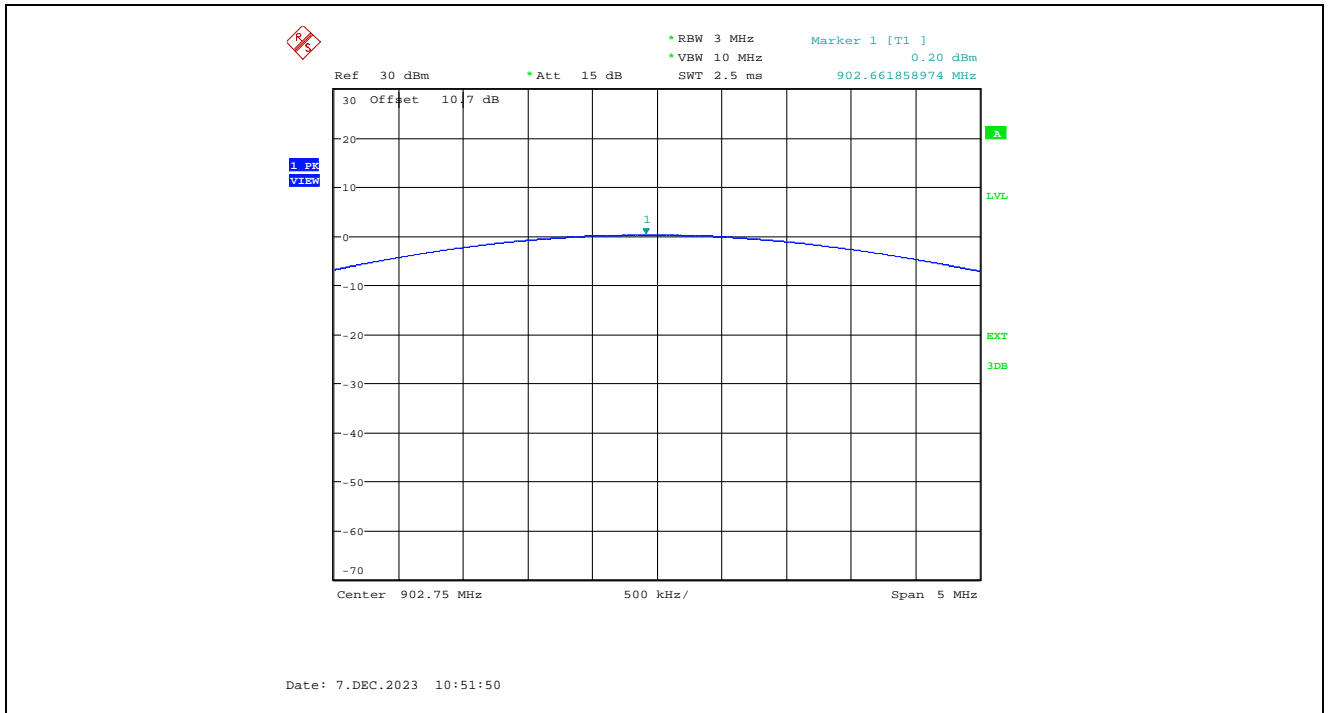

Plot 5.4.4.1.17. XB-9XR-DMUM-001 Maximum Peak Conducted Output Power, Low Power Setting, 250 kbps, 915.25 MHz

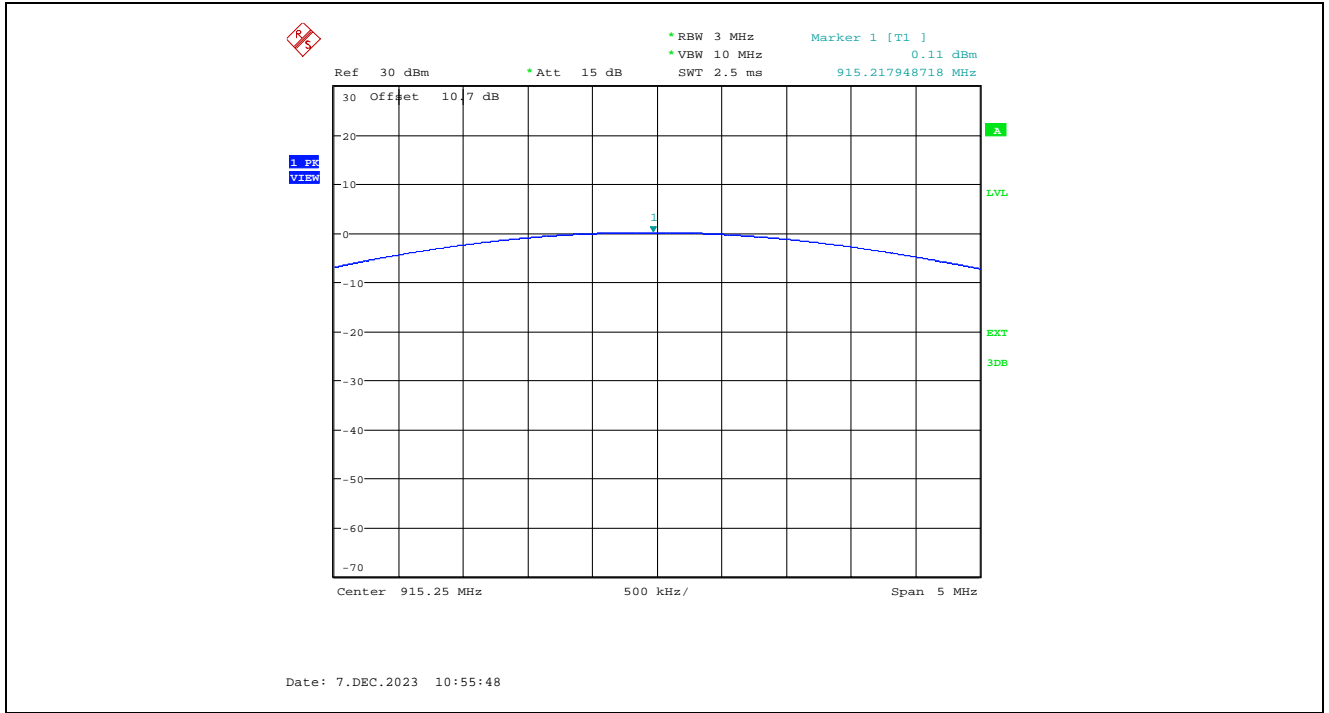

Plot 5.4.4.1.18. XB-9XR-DMUM-001 Maximum Peak Conducted Output Power, Low Power Setting, 250 kbps, 927.25 MHz

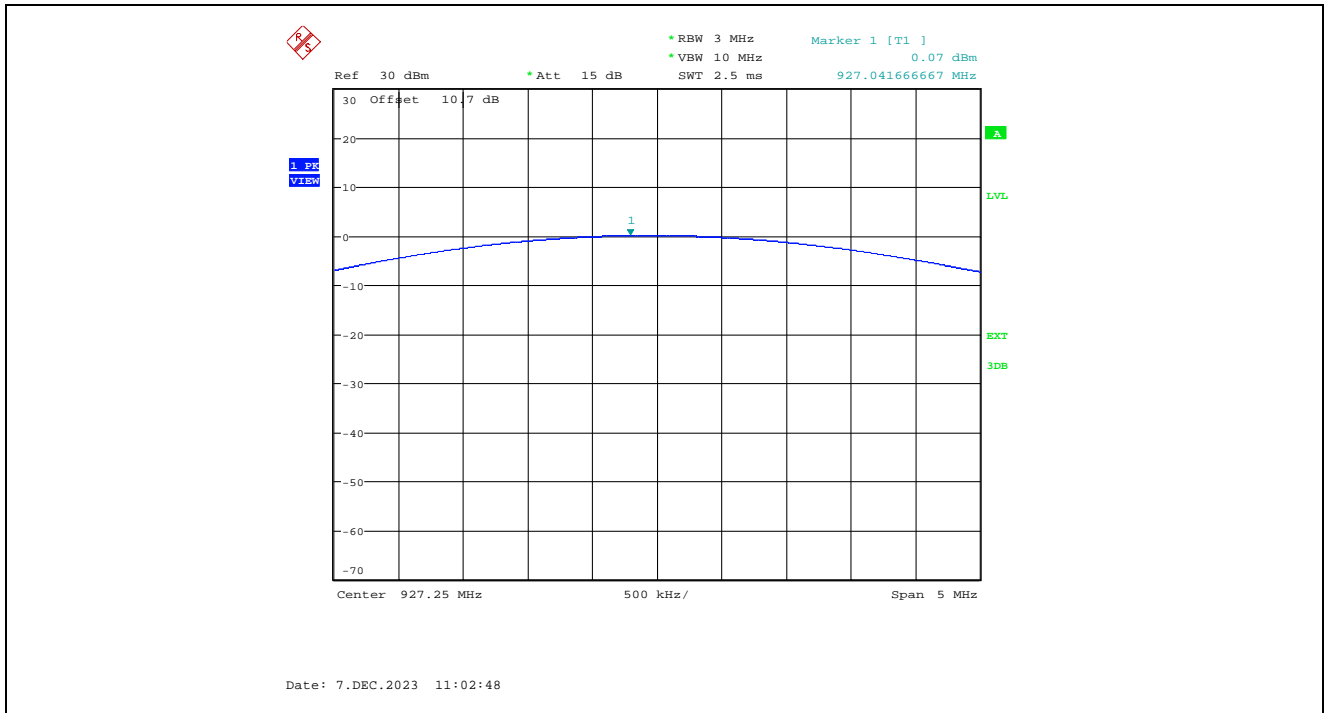

5.4.4.2. XB-9XR-DMUS-001 - Maximum Peak Conducted Output Power and EIRP

XB-9XR-DMUS-001 - Maximum Peak Conducted Output Power

Power Setting (High/Low)	Data Rate (kbps)	Frequency (MHz)	Maximum Peak Conducted Output Power		Peak Conducted Output Power Limit (dBm)
			(dBm)	(W)	
High	10	902.5	18.89	0.07745	30
		915	18.85	0.07674	30
		927	18.79	0.07568	30
	110	902.5	18.90	0.07762	30
		915	18.84	0.07656	30
		927	18.77	0.07534	30
	250	902.75	18.91	0.07780	30
		915.25	18.85	0.07674	30
		927.25	18.79	0.07568	30

XB-9XR-DMUS-001 - Power Level, Antenna Details and Resulting EIRP Values

Maximum Peak Conducted Output Power: 18.91 dBm					
Assembly #	Antenna Type	Maximum Gain (dBi)	Minimum Insertion / Cable Loss (dBm)	Antenna Assembly Gain (dBm)	EIRP (dBm)
1	Flat Antenna	2	0	2	20.91
2	Dipole Antenna	2.96	0.3	2.66	21.57
3	Omni Directional Antenna	8.0	0.62	7.38	26.29
4	Yagi Antenna	15.1	0.62	14.48	33.39
5	Flex Antenna	1	0	1	19.91
6	Phantom (Dome) Antenna	3	0.62	2.38	21.29
7	Ceramic Chip Antenna	0.8	0	0.8	19.71

Refer to the following for test data plots.

Plot 5.4.4.2.1. XB-9XR-DMUS-001 - Maximum Peak Conducted Output Power, High Power Setting, 10 kbps, 902.5 MHz

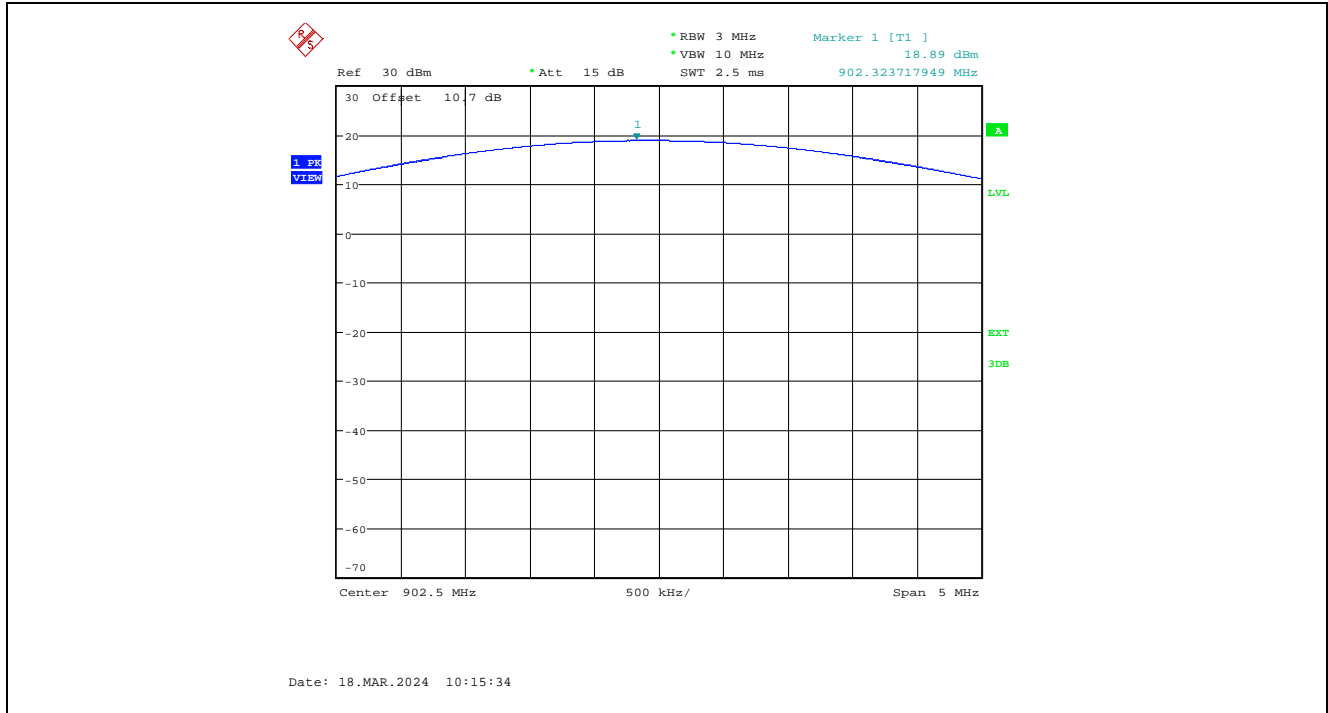

Plot 5.4.4.2.2. XB-9XR-DMUS-001 - Maximum Peak Conducted Output Power, High Power Setting, 10 kbps, 915 MHz

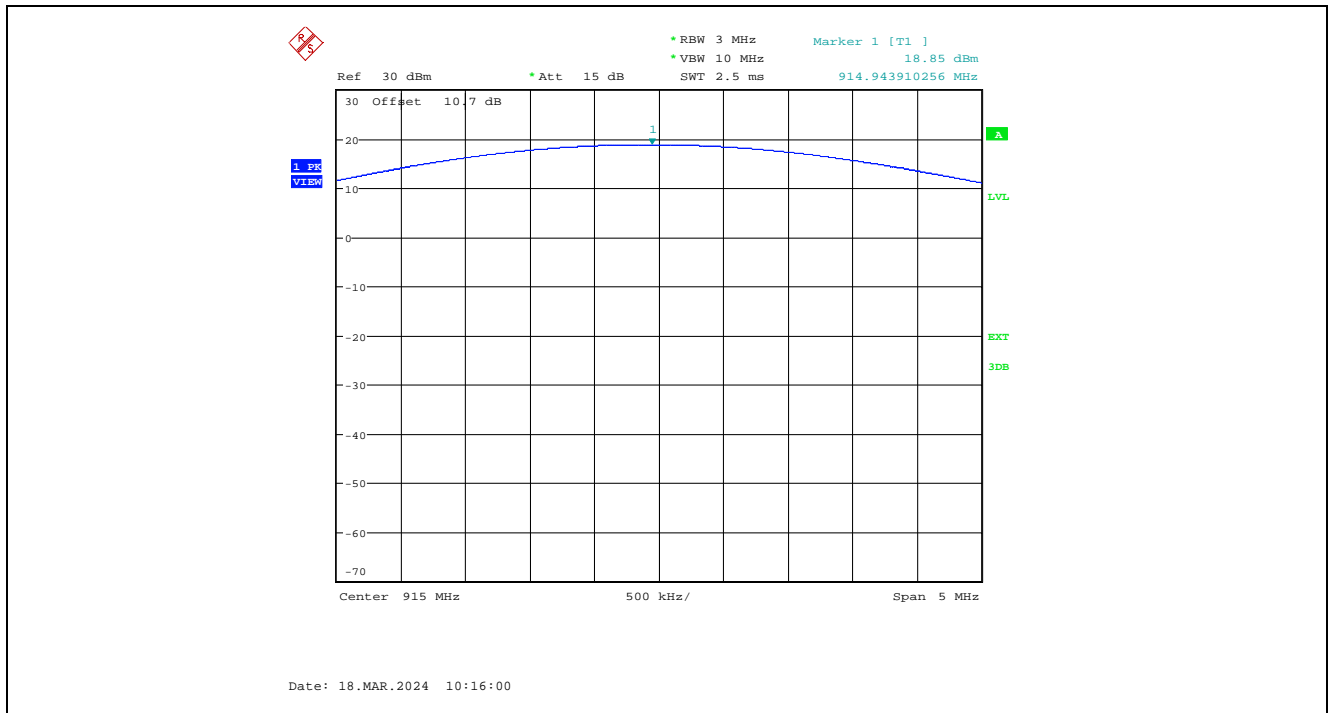

Plot 5.4.4.2.3. XB-9XR-DMUS-001 - Maximum Peak Conducted Output Power, High Power Setting, 10 kbps, 927 MHz

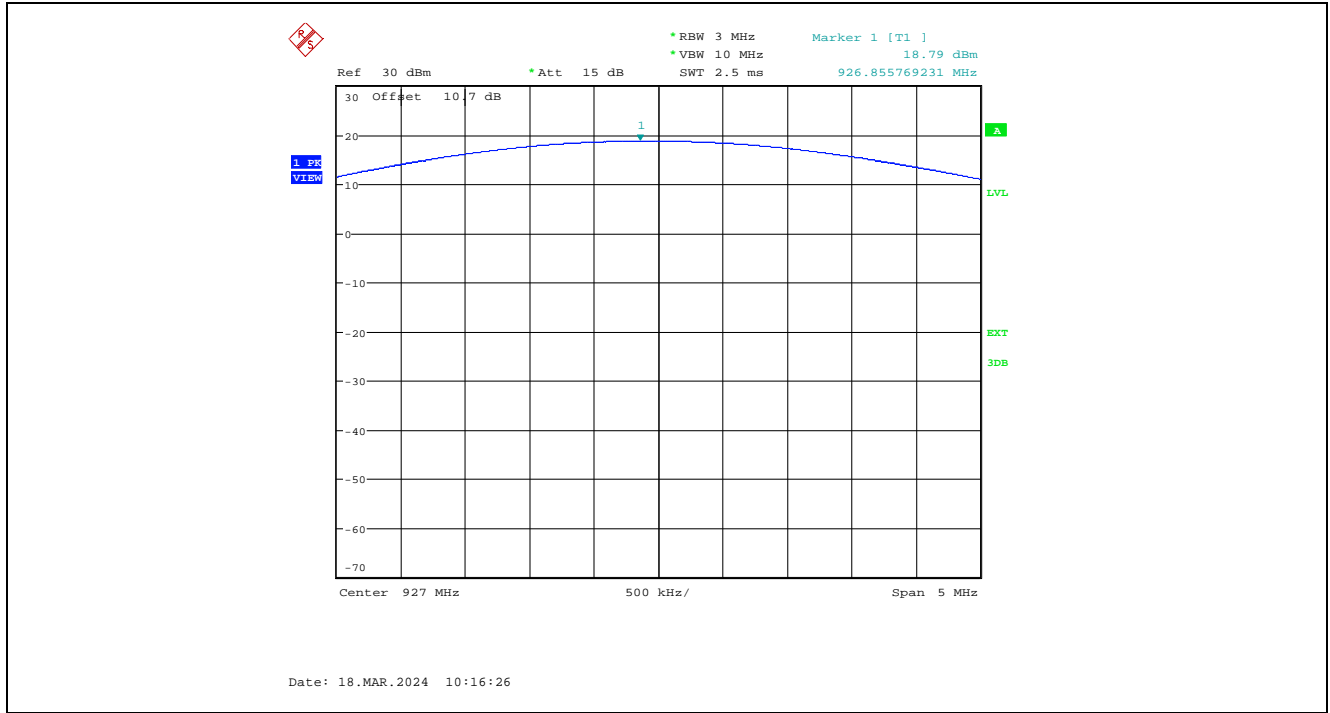

Plot 5.4.4.2.4. XB-9XR-DMUS-001 - Maximum Peak Conducted Output Power, High Power Setting, 110 kbps, 902.5 MHz

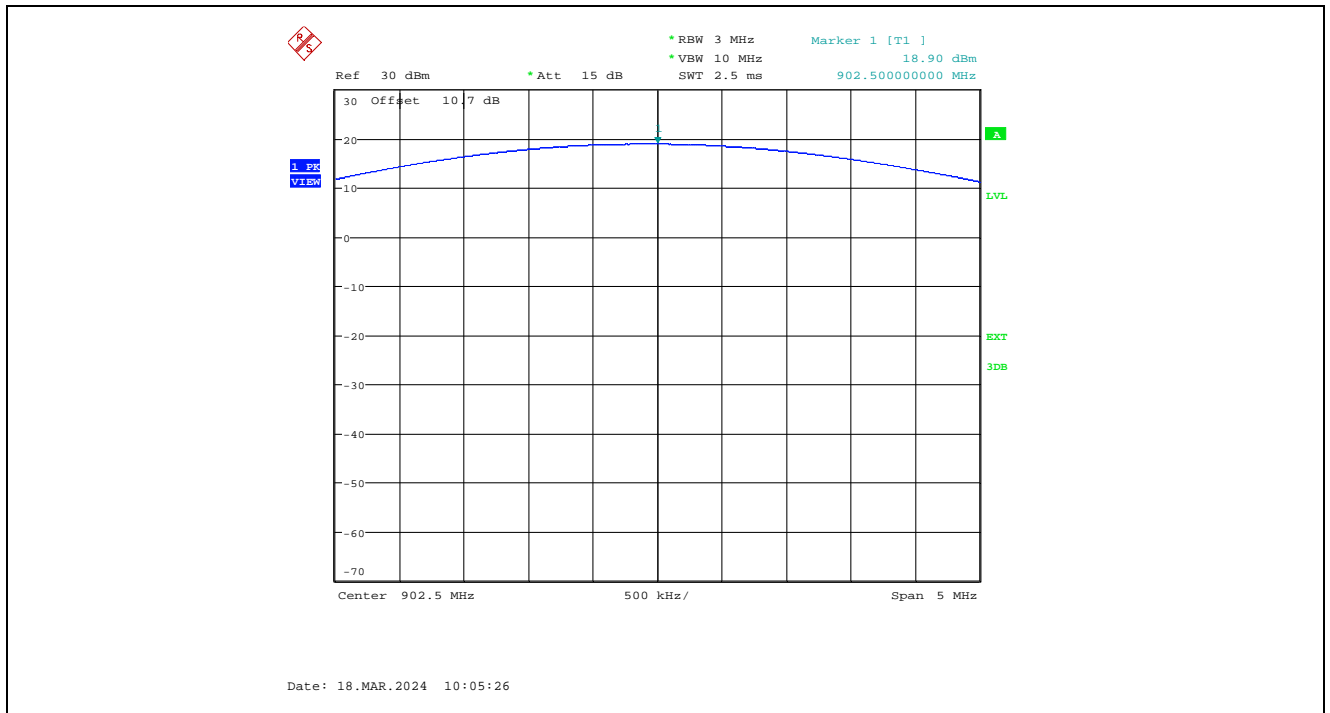

Plot 5.4.4.2.5. XB-9XR-DMUS-001 - Maximum Peak Conducted Output Power, High Power Setting, 110 kbps, 915 MHz

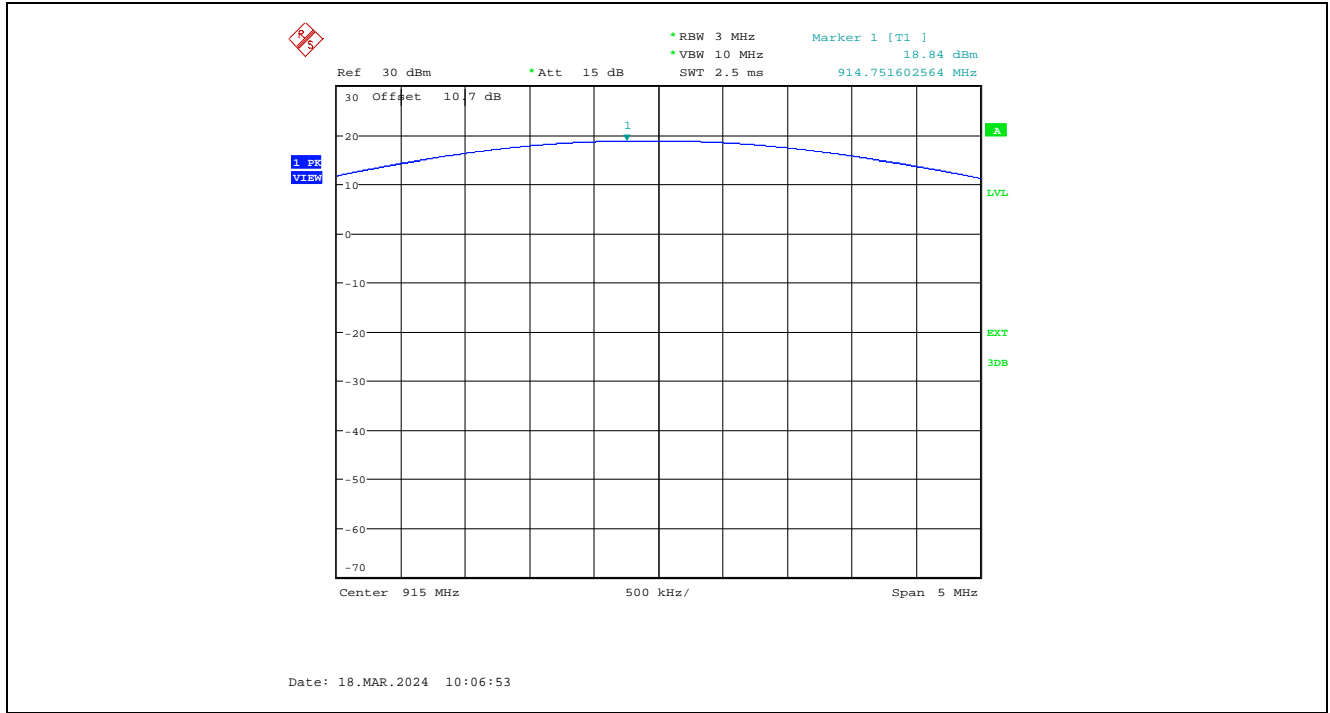

Plot 5.4.4.2.6. XB-9XR-DMUS-001 - Maximum Peak Conducted Output Power, High Power Setting, 110 kbps, 927 MHz

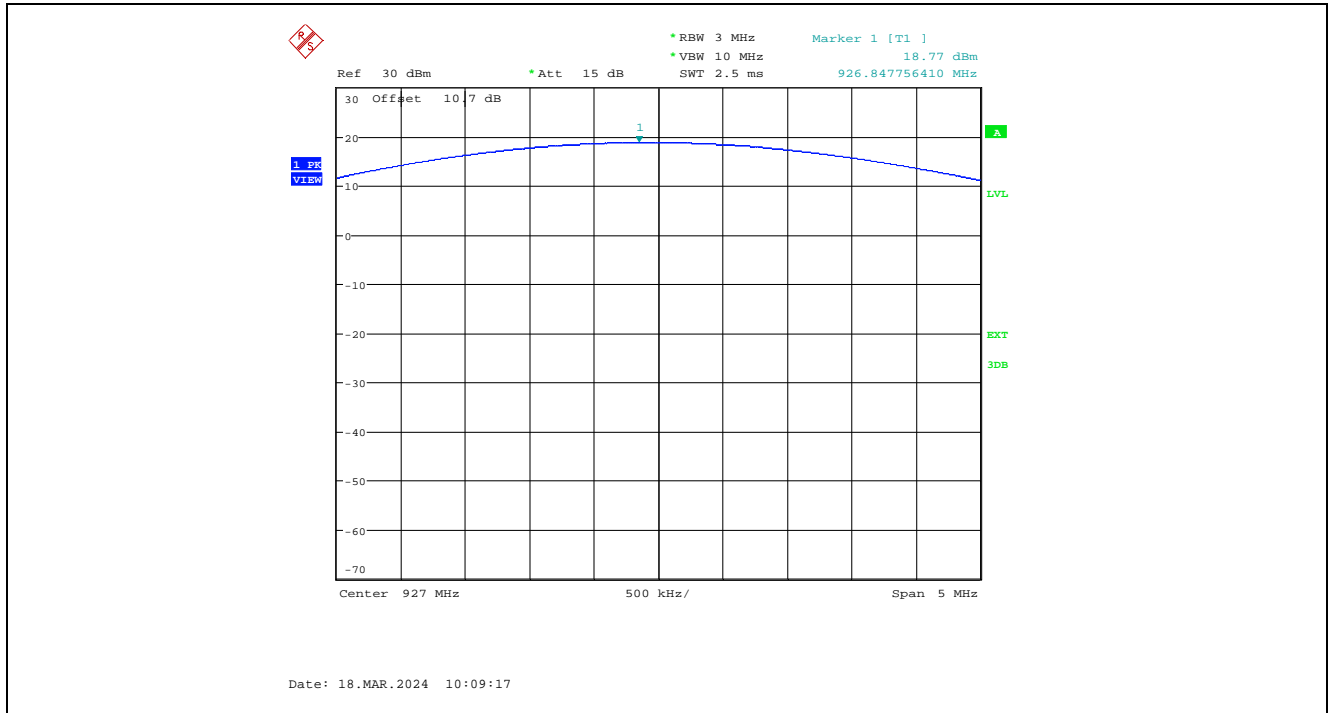

Plot 5.4.4.2.7. XB-9XR-DMUS-001 - Maximum Peak Conducted Output Power, High Power Setting, 250 kbps, 902.75 MHz

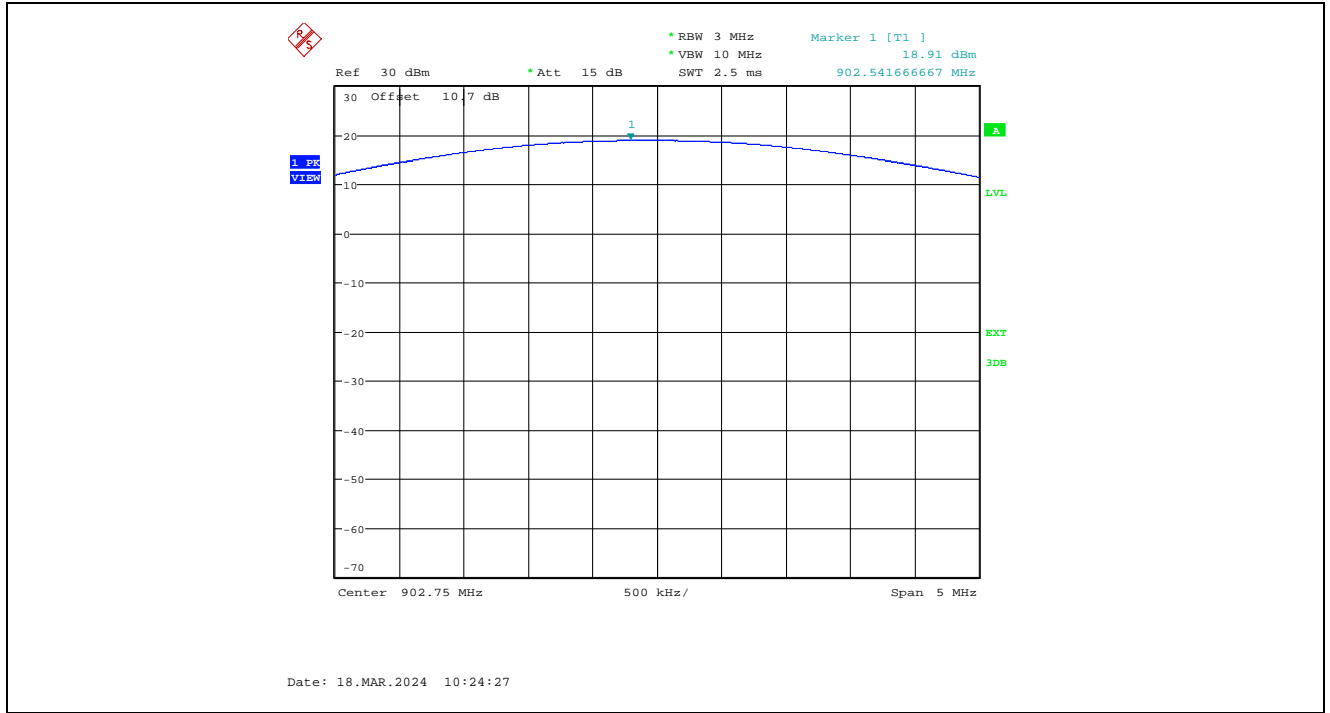

Plot 5.4.4.2.8. XB-9XR-DMUS-001 - Maximum Peak Conducted Output Power, High Power Setting, 250 kbps, 915.25 MHz

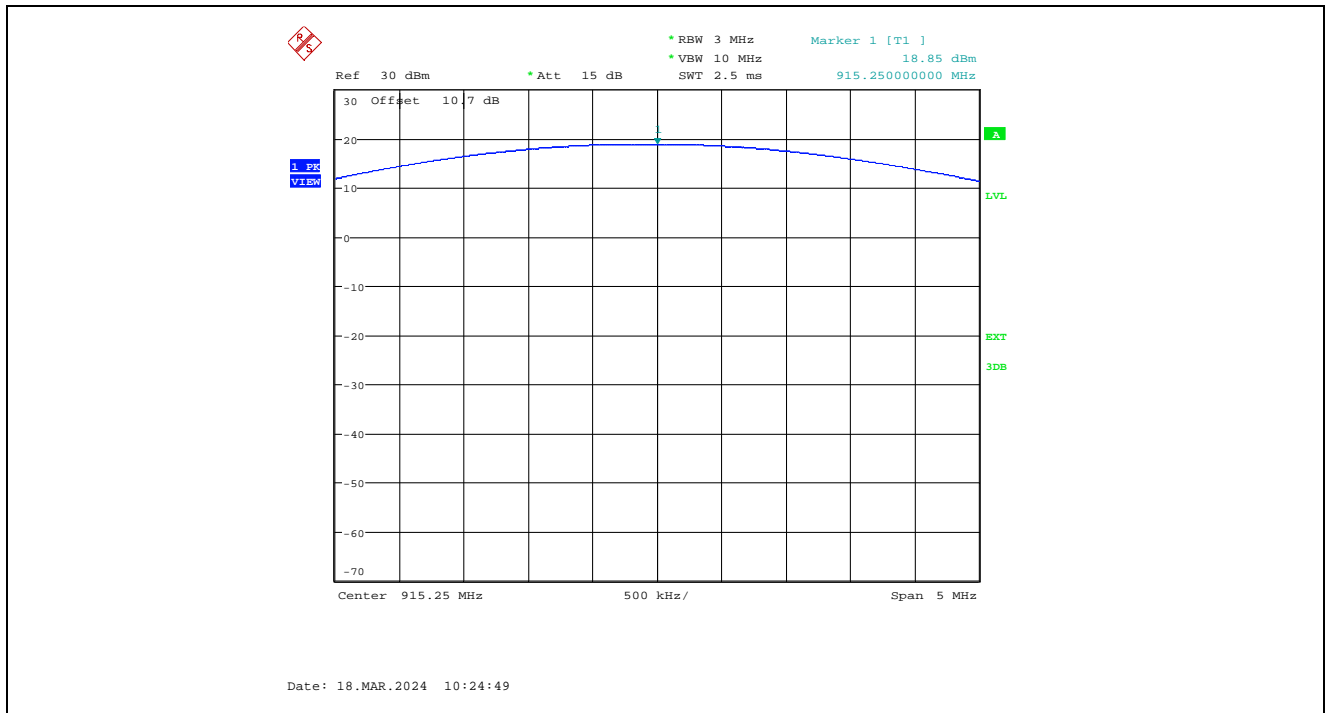

Plot 5.4.4.2.9. XB-9XR-DMUS-001 - Maximum Peak Conducted Output Power, High Power Setting, 250 kbps, 927.25 MHz

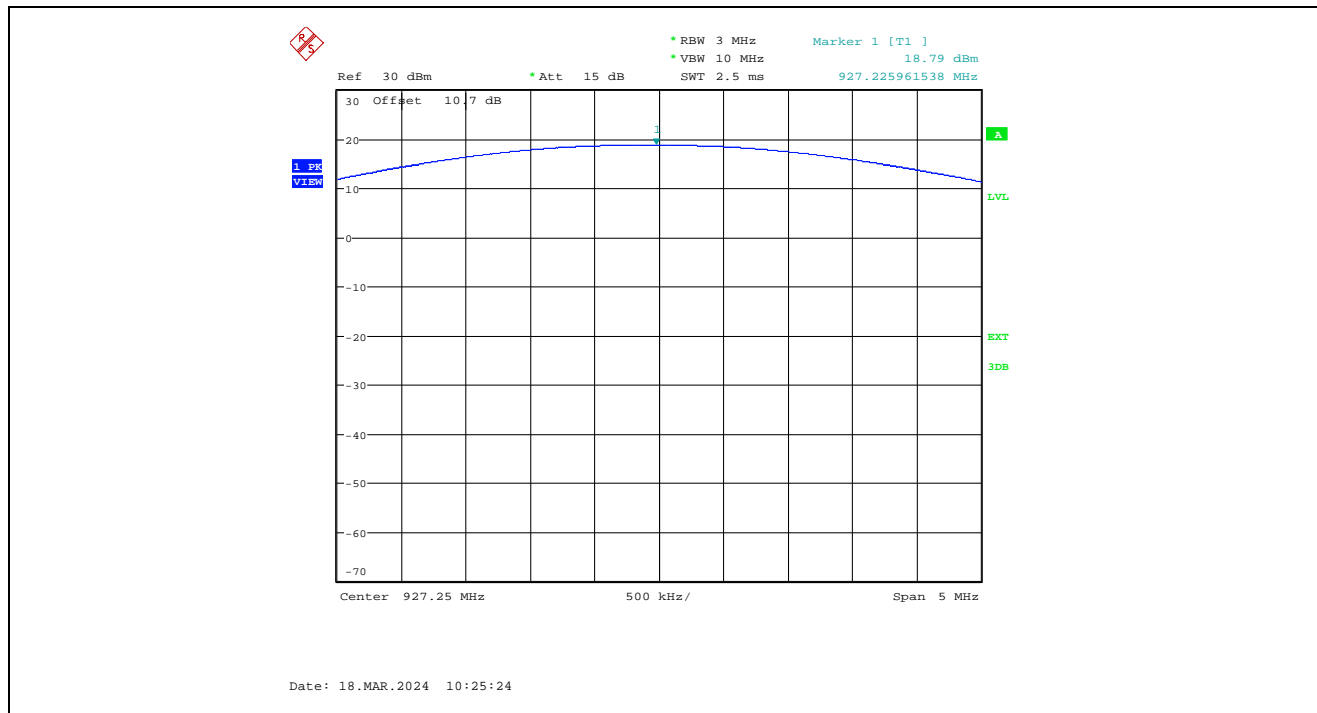

5.4.4.3. XB-9XR-DMUT-001 - Maximum Peak Conducted Output Power and EIRP

XB-9XR-DMUT-001 - Maximum Peak Conducted Output Power

Power Setting (High/Low)	Data Rate (kbps)	Frequency (MHz)	Maximum Peak Conducted Output Power		Peak Conducted Output Power Limit (dBm)
			(dBm)	(W)	
High	10	902.5	18.72	0.07447	30
		915	18.70	0.07413	30
		927	18.65	0.07328	30
	110	902.5	18.73	0.07464	30
		915	18.71	0.07430	30
		927	18.67	0.07362	30
	250	902.75	18.75	0.07499	30
		915.25	18.70	0.07413	30
		927.25	18.63	0.07295	30

XB-9XR-DMUT-001 - Power Level, Antenna Details and Resulting EIRP Values

Maximum Peak Conducted Output Power: 18.75 dBm					
Assembly #	Antenna Type	Maximum Gain (dBi)	Minimum Insertion / Cable Loss (dBm)	Antenna Assembly Gain (dBm)	EIRP (dBm)
1	Flat Antenna	2	0	2	20.75
2	Dipole Antenna	2.96	0.3	2.66	21.41
3	Omni Directional Antenna	8.0	0.62	7.38	26.13
4	Yagi Antenna	15.1	0.62	14.48	33.23
5	Flex Antenna	1	0	1	19.75
6	Phantom (Dome) Antenna	3	0.62	2.38	21.13
7	Ceramic Chip Antenna	0.8	0	0.8	19.55

Refer to the following for test data plots.

Plot 5.4.4.3.1. XB-9XR-DMUT-001 - Maximum Peak Conducted Output Power, High Power Setting, 10 kbps, 902.5 MHz

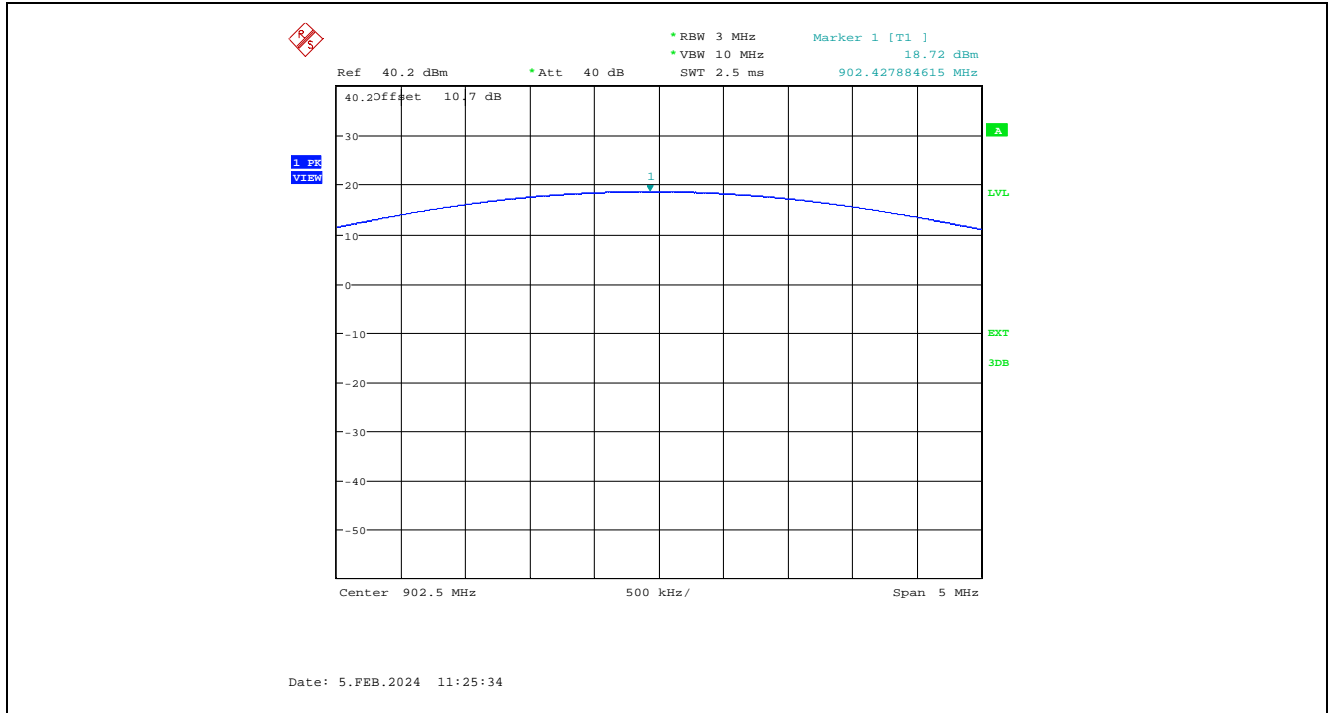

Plot 5.4.4.3.2. XB-9XR-DMUT-001 - Maximum Peak Conducted Output Power, High Power Setting, 10 kbps, 915 MHz

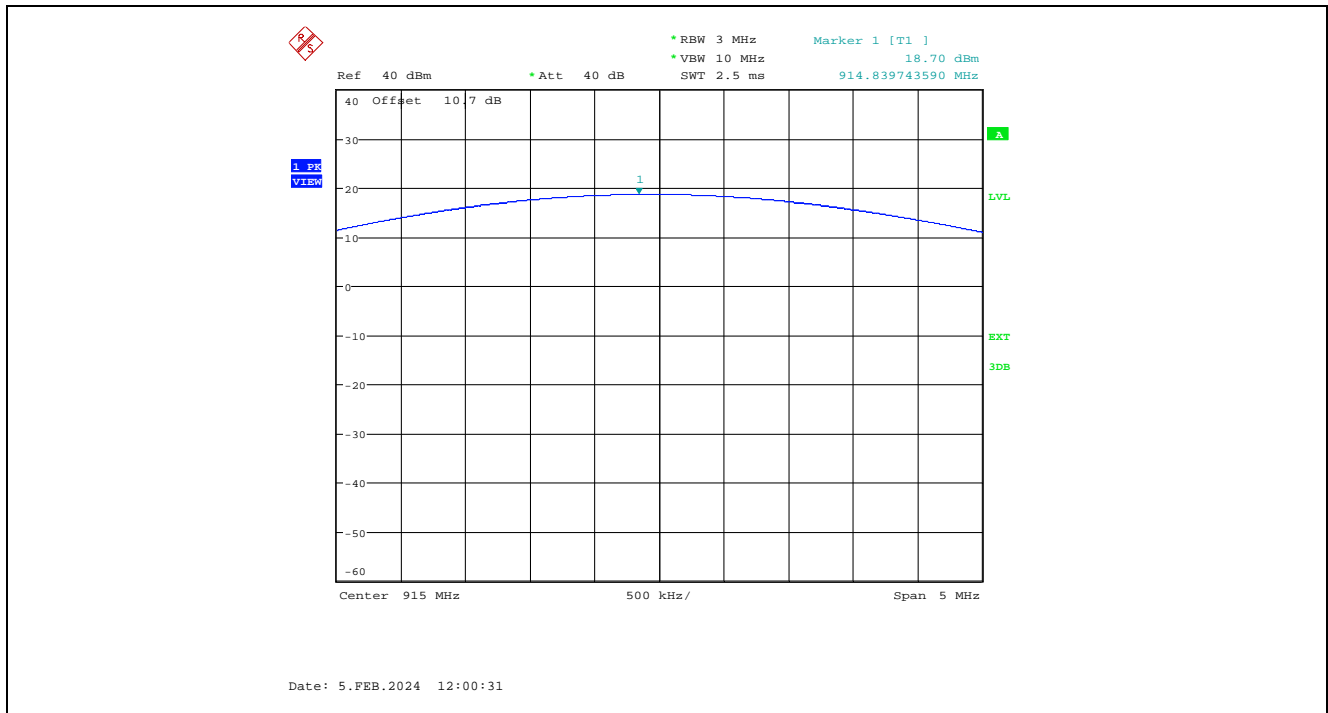

Plot 5.4.4.3.3. XB-9XR-DMUT-001 - Maximum Peak Conducted Output Power, High Power Setting, 10 kbps, 927 MHz

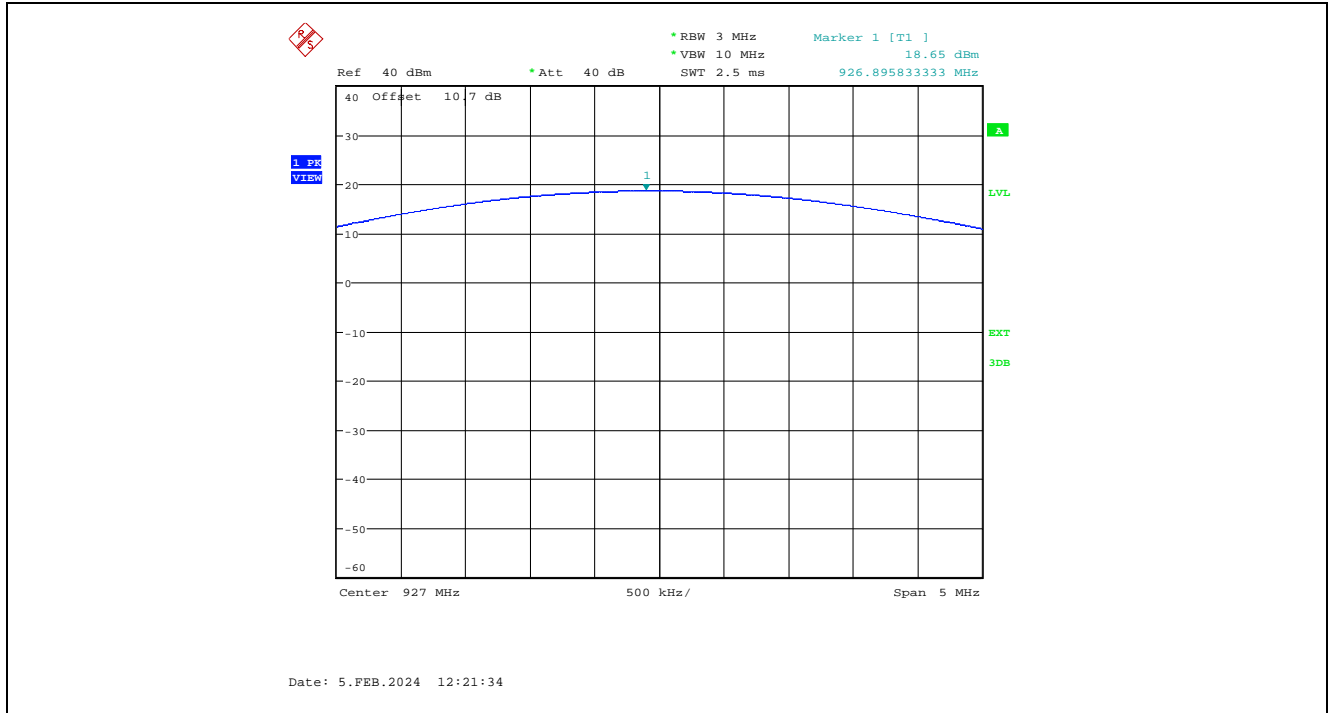

Plot 5.4.4.3.4. XB-9XR-DMUT-001 - Maximum Peak Conducted Output Power, High Power Setting, 110 kbps, 902.5 MHz

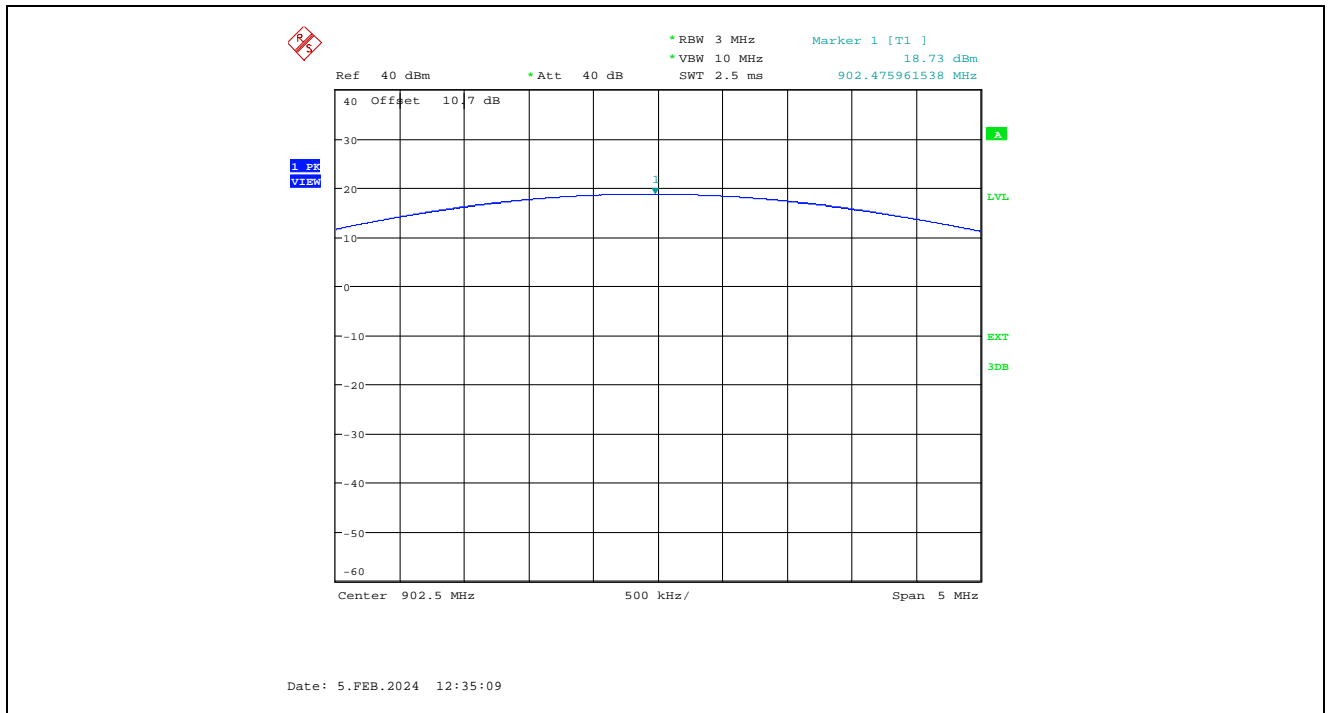

Plot 5.4.4.3.5. XB-9XR-DMUT-001 - Maximum Peak Conducted Output Power, High Power Setting, 110 kbps, 915 MHz

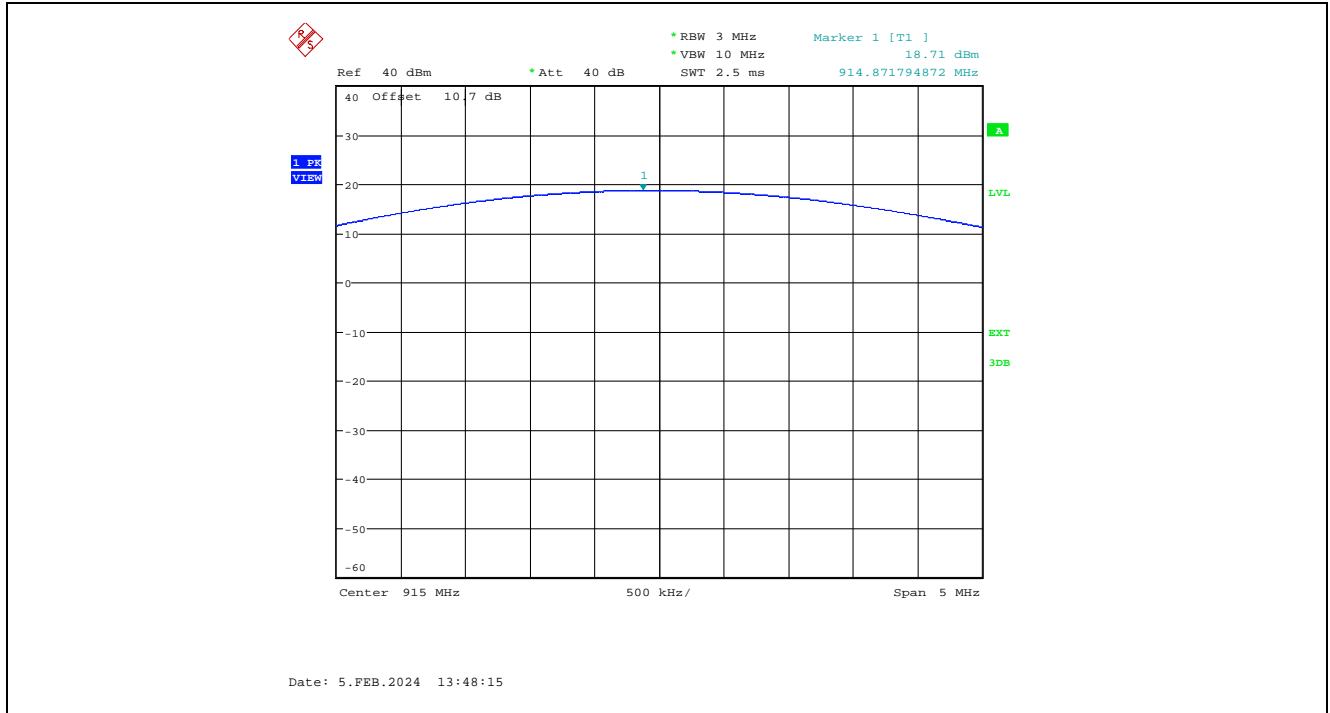

Plot 5.4.4.3.6. XB-9XR-DMUT-001 - Maximum Peak Conducted Output Power, High Power Setting, 110 kbps, 927 MHz

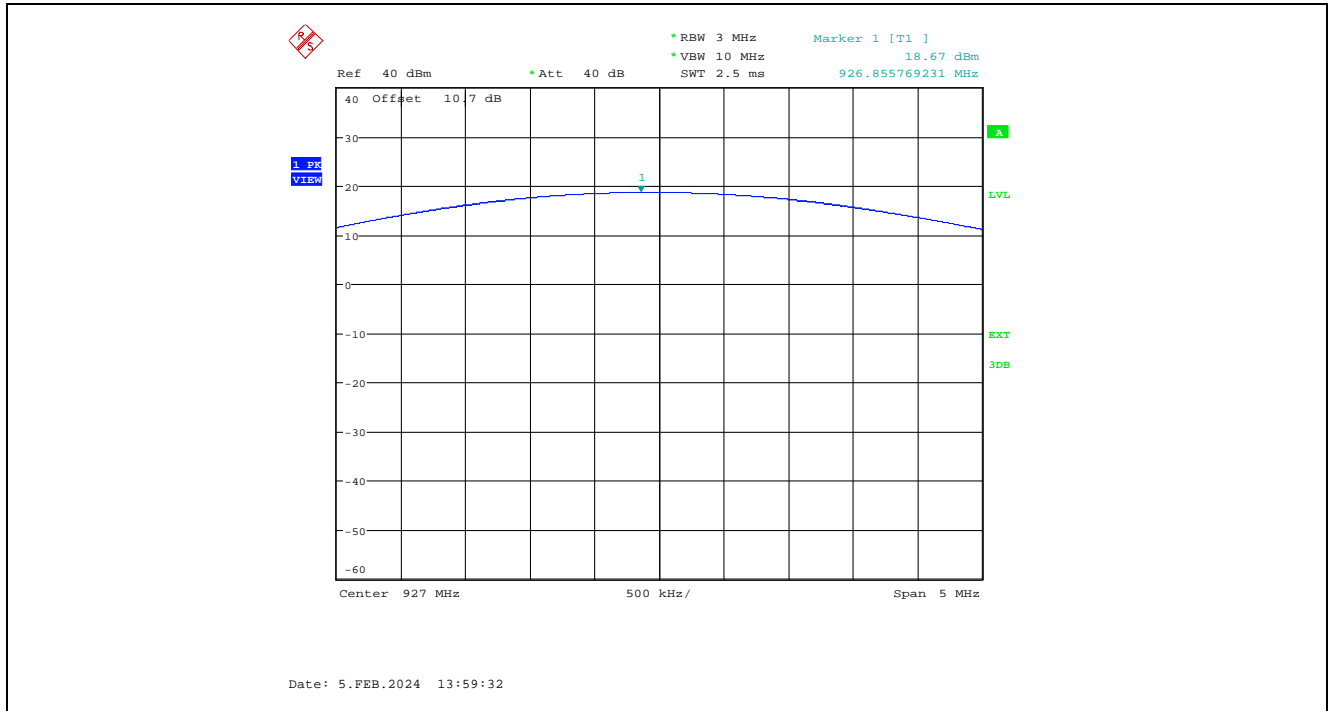

Plot 5.4.4.3.7. XB-9XR-DMUT-001 - Maximum Peak Conducted Output Power, High Power Setting, 250 kbps, 902.75 MHz

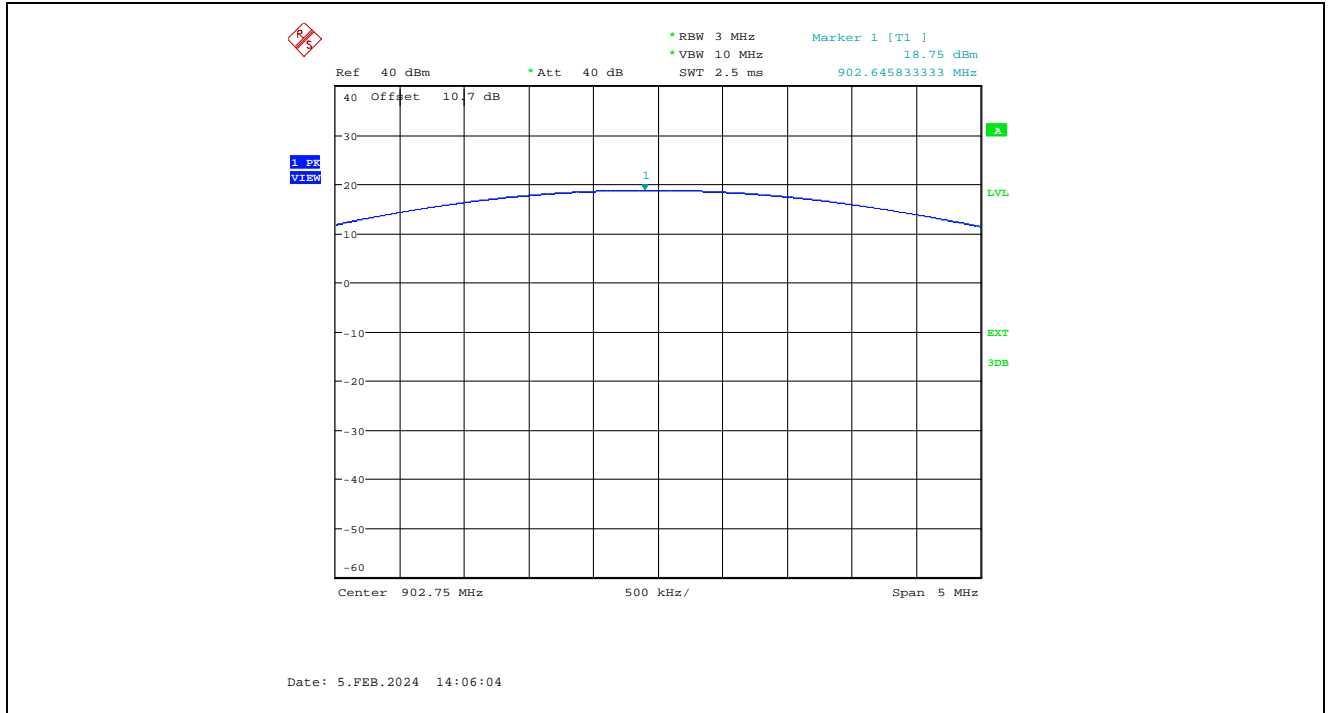

Plot 5.4.4.3.8. XB-9XR-DMUT-001 - Maximum Peak Conducted Output Power, High Power Setting, 250 kbps, 915.25 MHz

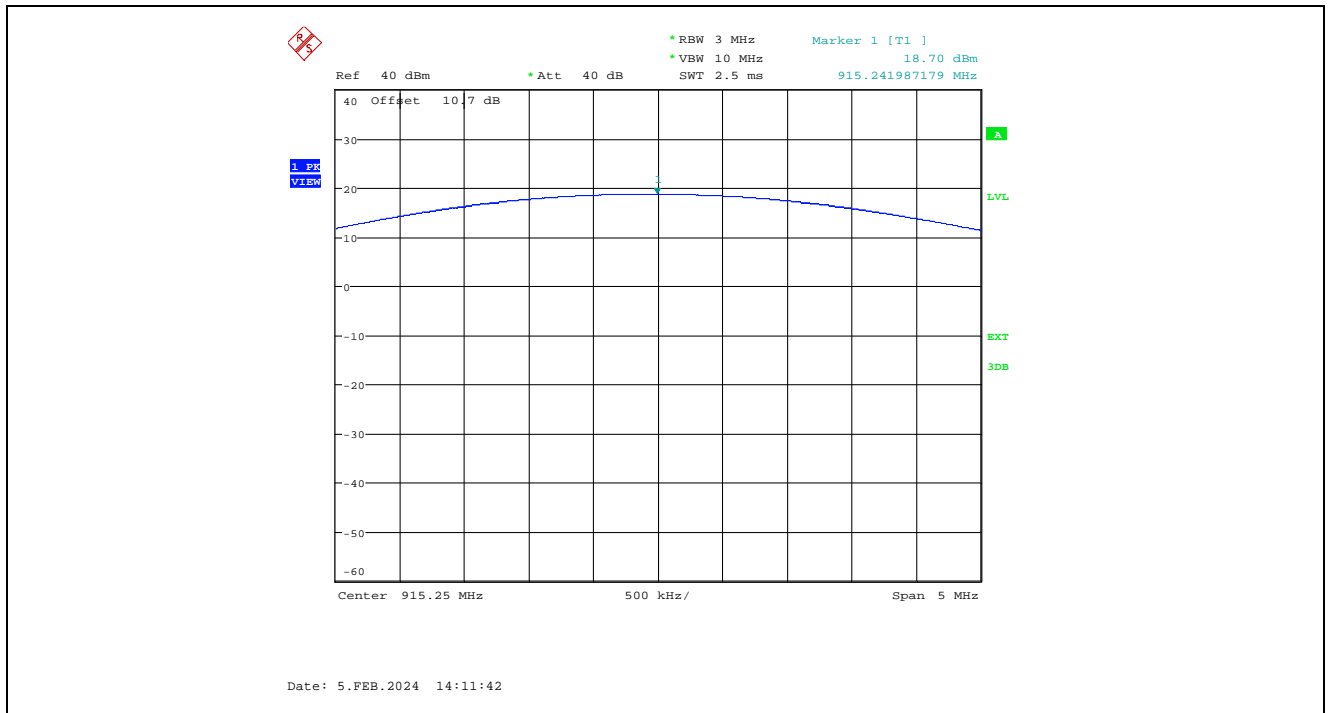

Plot 5.4.4.3.9. XB-9XR-DMUT-001 - Maximum Peak Conducted Output Power, High Power Setting, 250 kbps, 927.25 MHz

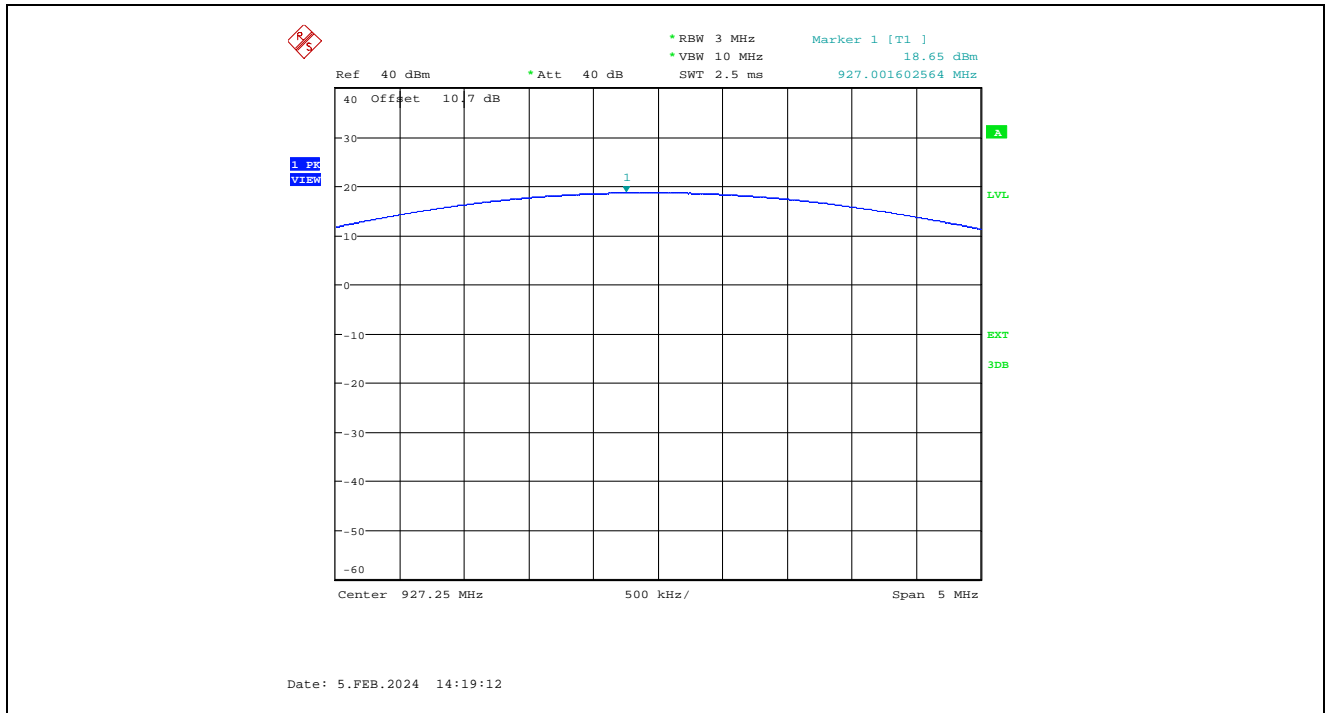

5.4.4.4. XB-9XR-DMST-001 - Maximum Peak Conducted Output Power and EIRP

XB-9XR-DMST-001 - Maximum Peak Conducted Output Power

Power Setting (High/Low)	Data Rate (kbps)	Frequency (MHz)	Maximum Peak Conducted Output Power		Peak Conducted Output Power Limit (dBm)
			(dBm)	(W)	
High	10	902.5	18.83	0.07638	30
		915	18.80	0.07586	30
		927	18.75	0.07499	30
	110	902.5	18.84	0.07656	30
		915	18.80	0.07586	30
		927	18.75	0.07499	30
	250	902.75	18.81	0.07603	30
		915.25	18.78	0.07551	30
		927.25	18.70	0.07413	30

XB-9XR-DMST-001 - Power Level, Antenna Details and Resulting EIRP Values

Maximum Peak Conducted Output Power: 18.84 dBm					
Assembly #	Antenna Type	Maximum Gain (dBi)	Minimum Insertion / Cable Loss (dBm)	Antenna Assembly Gain (dBm)	EIRP (dBm)
1	Flat Antenna	2	0	2	20.84
2	Dipole Antenna	2.96	0.3	2.66	21.50
3	Omni Directional Antenna	8.0	0.62	7.38	26.22
4	Yagi Antenna	15.1	0.62	14.48	33.32
5	Flex Antenna	1	0	1	19.84
6	Phantom (Dome) Antenna	3	0.62	2.38	21.22
7	Ceramic Chip Antenna	0.8	0	0.8	19.64

Refer to the following for test data plots.

Plot 5.4.4.4.1. XB-9XR-DMST-001 - Maximum Peak Conducted Output Power, High Power Setting, 10 kbps, 902.5 MHz

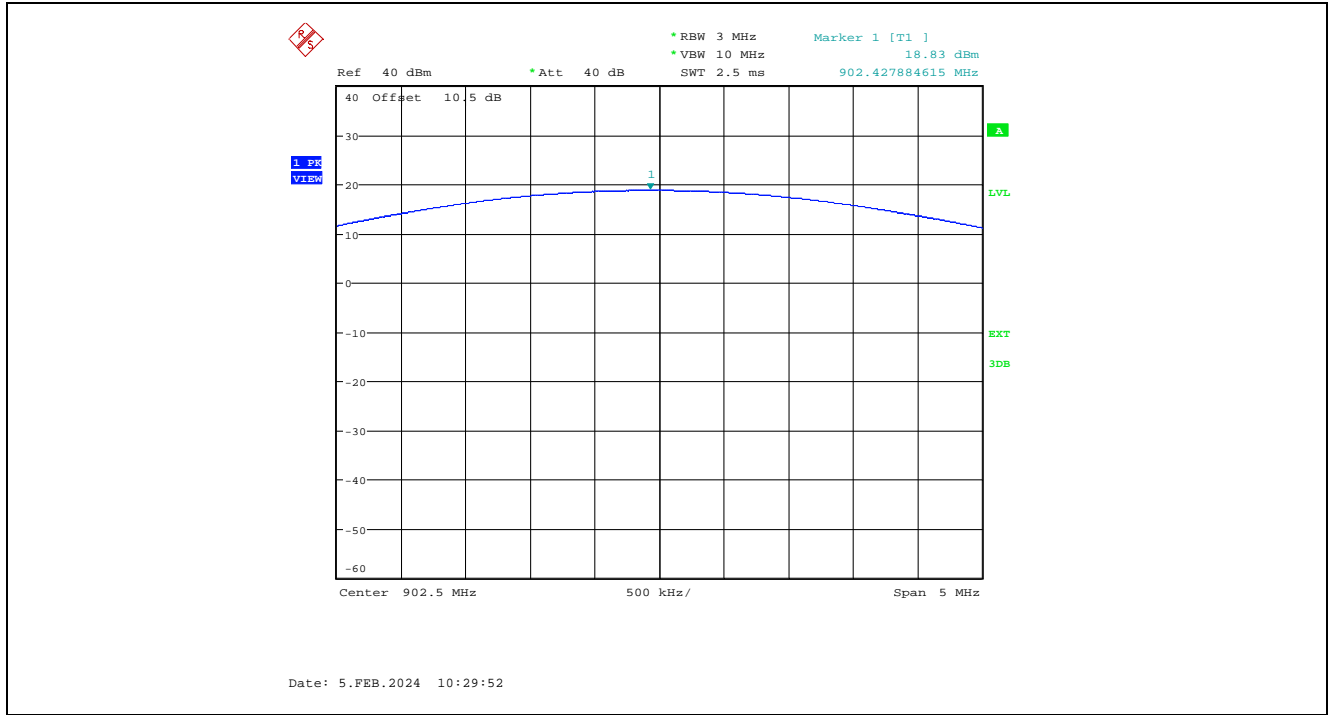

Plot 5.4.4.4.2. XB-9XR-DMST-001 - Maximum Peak Conducted Output Power, High Power Setting, 10 kbps, 915 MHz

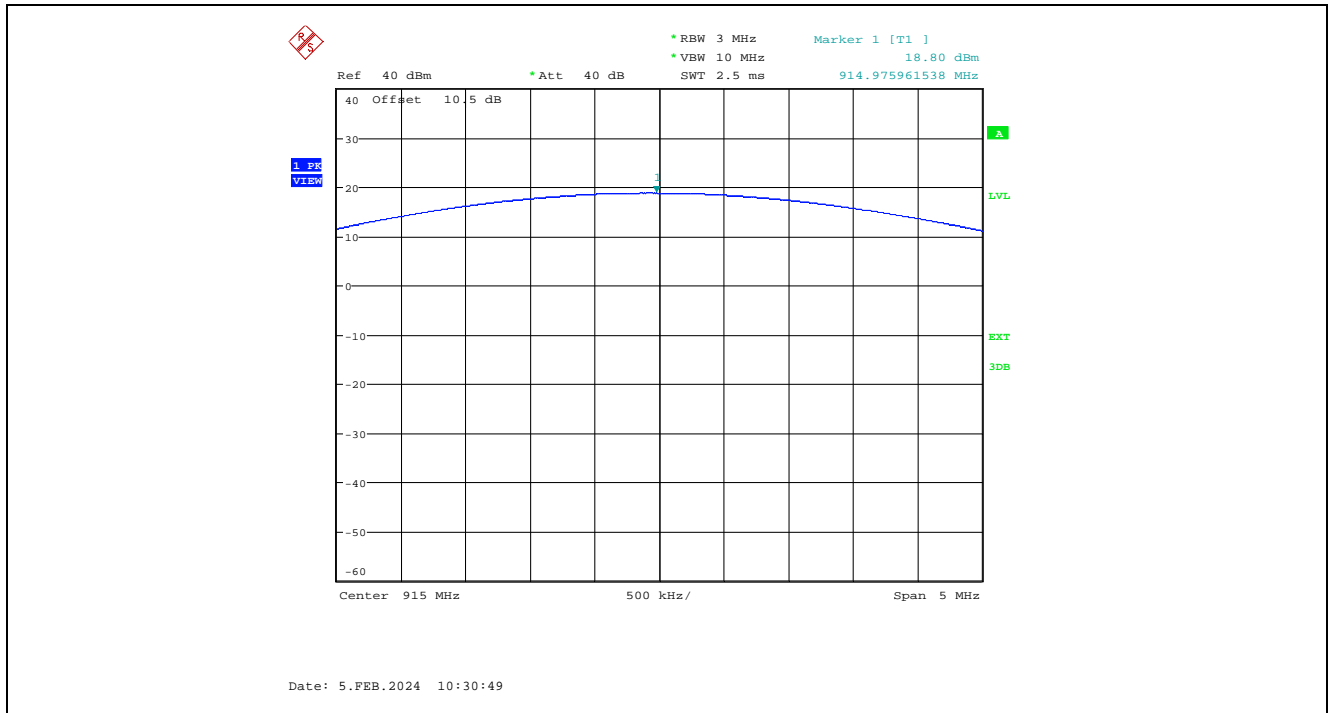

Plot 5.4.4.4.3. XB-9XR-DMST-001 - Maximum Peak Conducted Output Power, High Power Setting, 10 kbps, 927 MHz

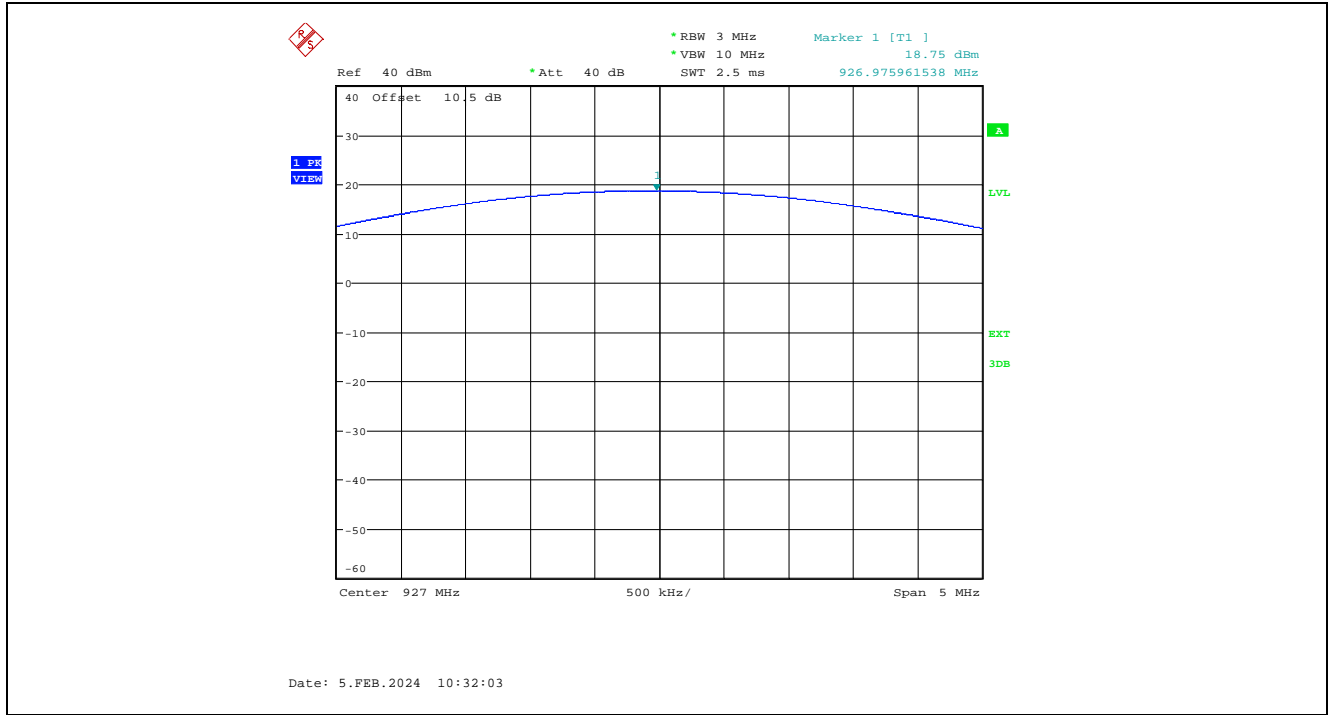

Plot 5.4.4.4.4. XB-9XR-DMST-001 - Maximum Peak Conducted Output Power, High Power Setting, 110 kbps, 902.5 MHz

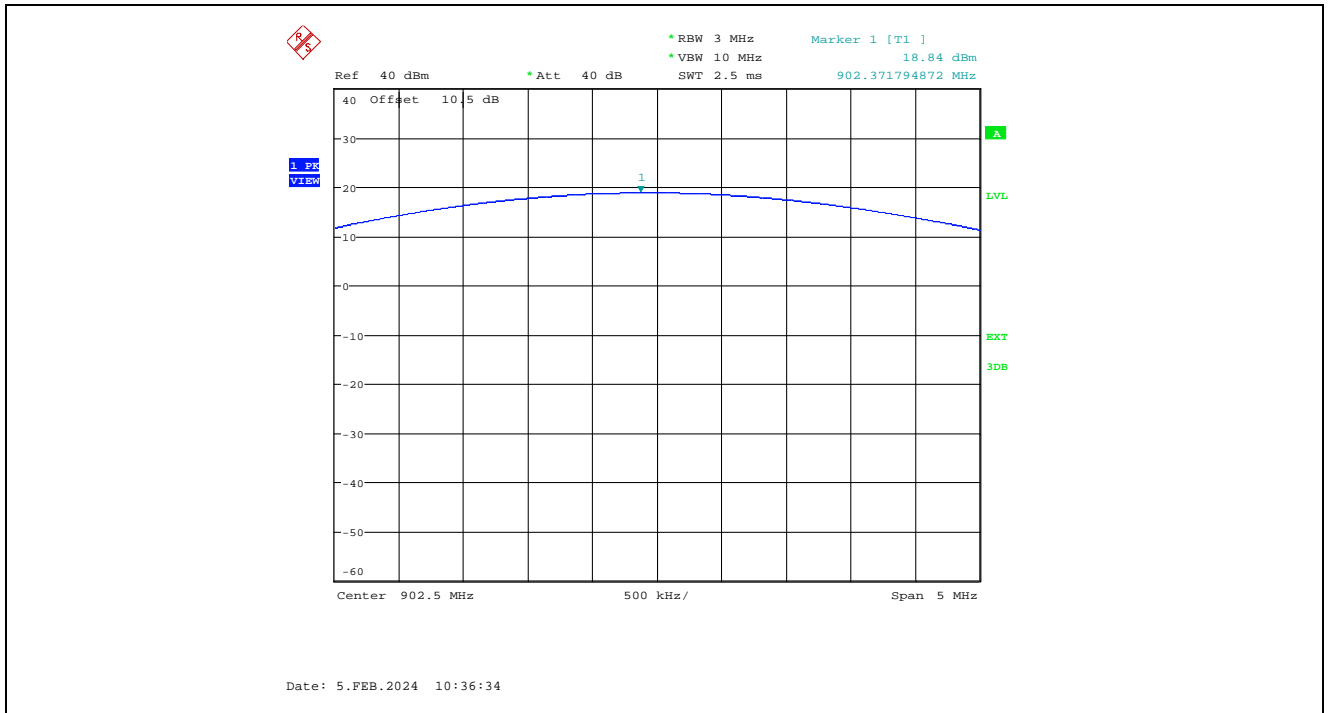

Plot 5.4.4.4.5. XB-9XR-DMST-001 - Maximum Peak Conducted Output Power, High Power Setting, 110 kbps, 915 MHz

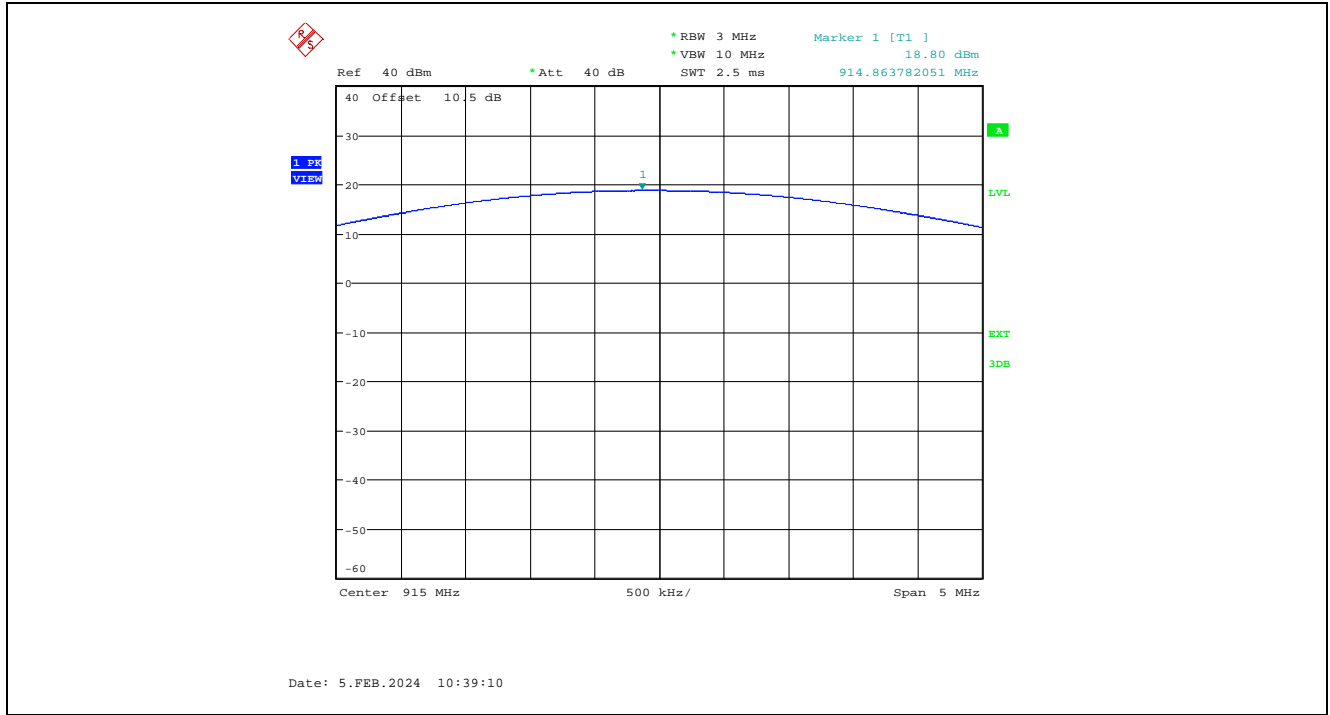

Plot 5.4.4.4.6. XB-9XR-DMST-001 - Maximum Peak Conducted Output Power, High Power Setting, 110 kbps, 927 MHz

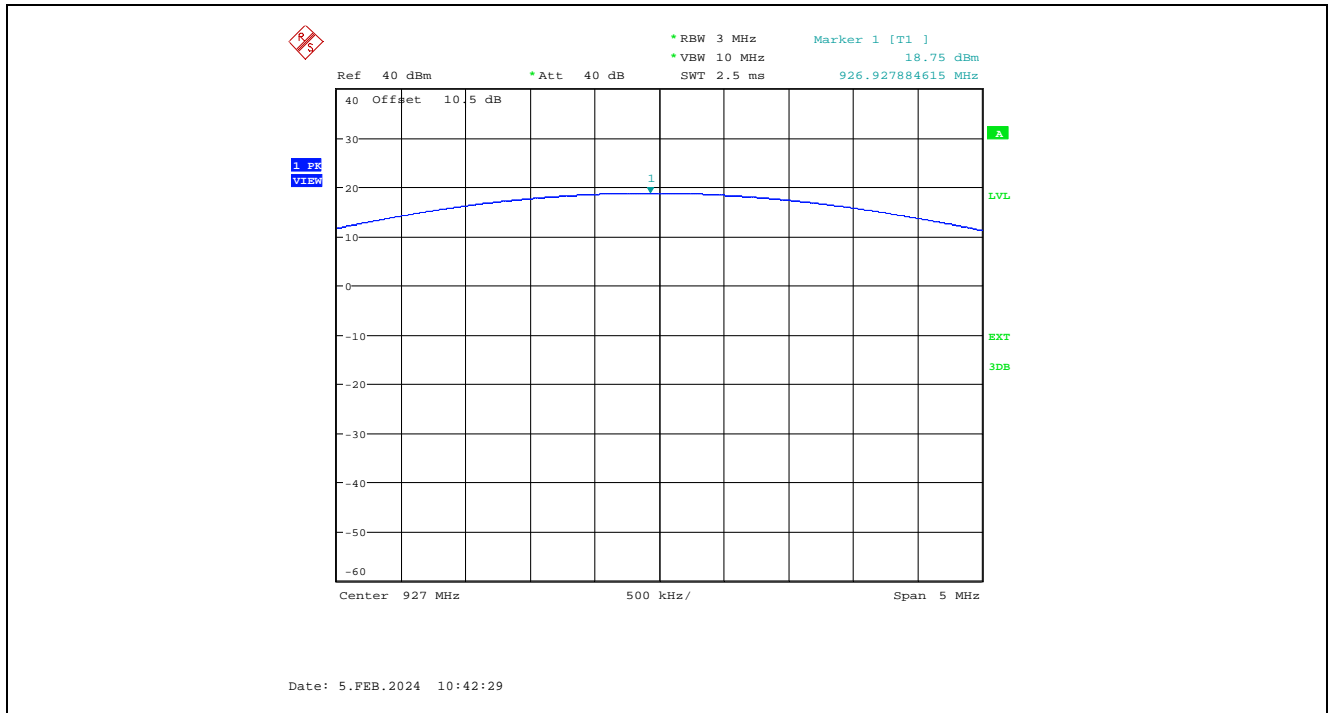

Plot 5.4.4.4.7. XB-9XR-DMST-001 - Maximum Peak Conducted Output Power, High Power Setting, 250 kbps, 902.75 MHz

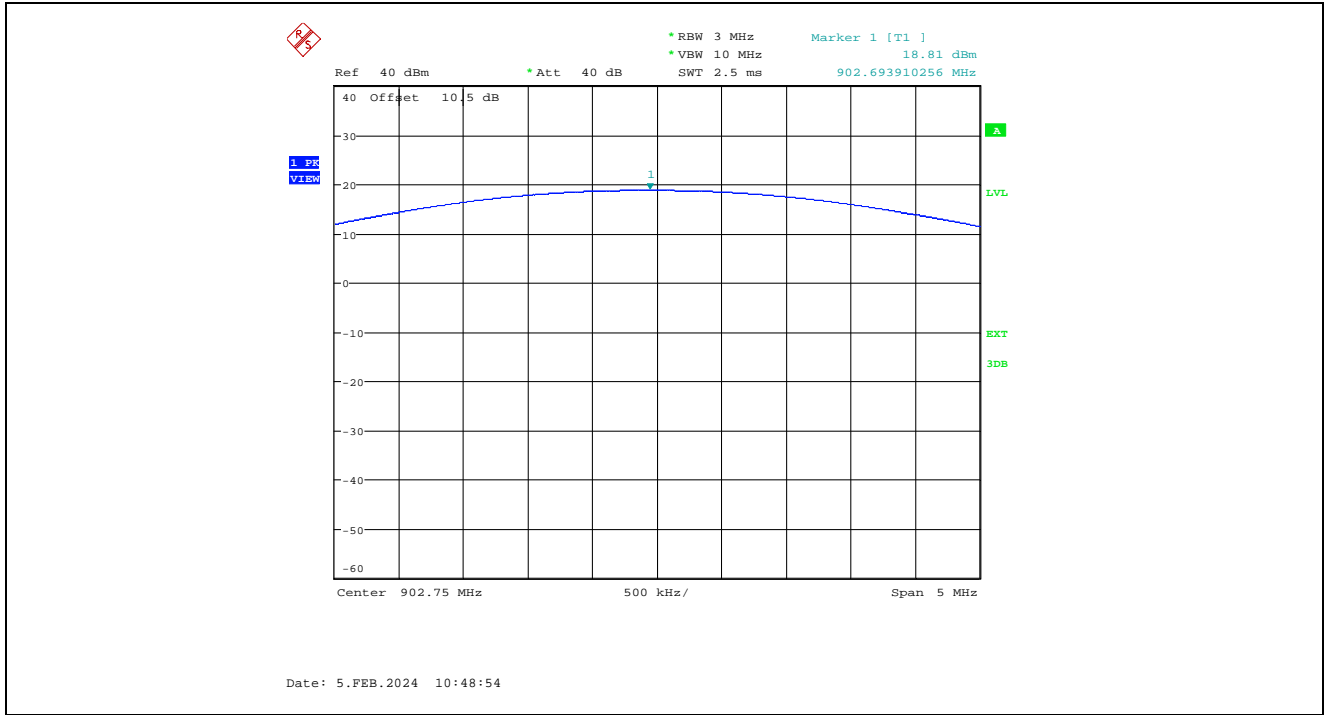

Plot 5.4.4.4.8. XB-9XR-DMST-001 - Maximum Peak Conducted Output Power, High Power Setting, 250 kbps, 915.25 MHz

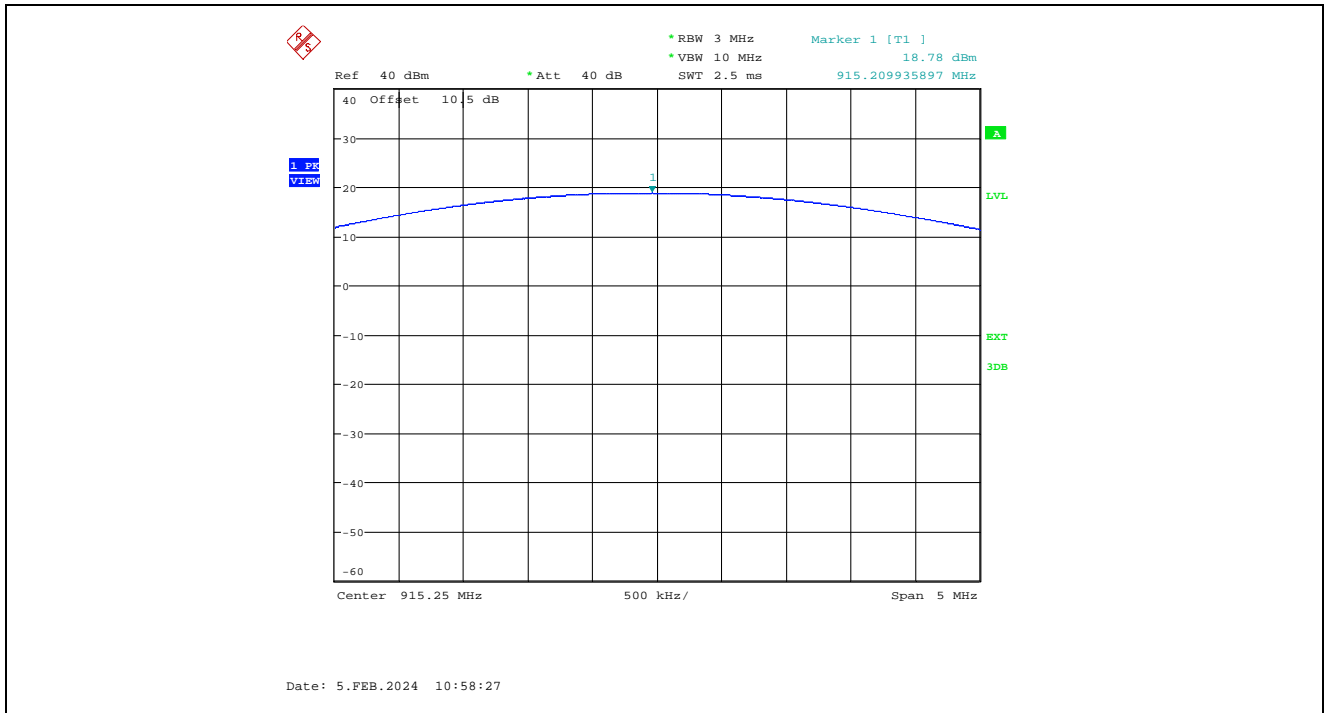

Plot 5.4.4.4.9. XB-9XR-DMST-001 - Maximum Peak Conducted Output Power, High Power Setting, 250 kbps, 927.25 MHz

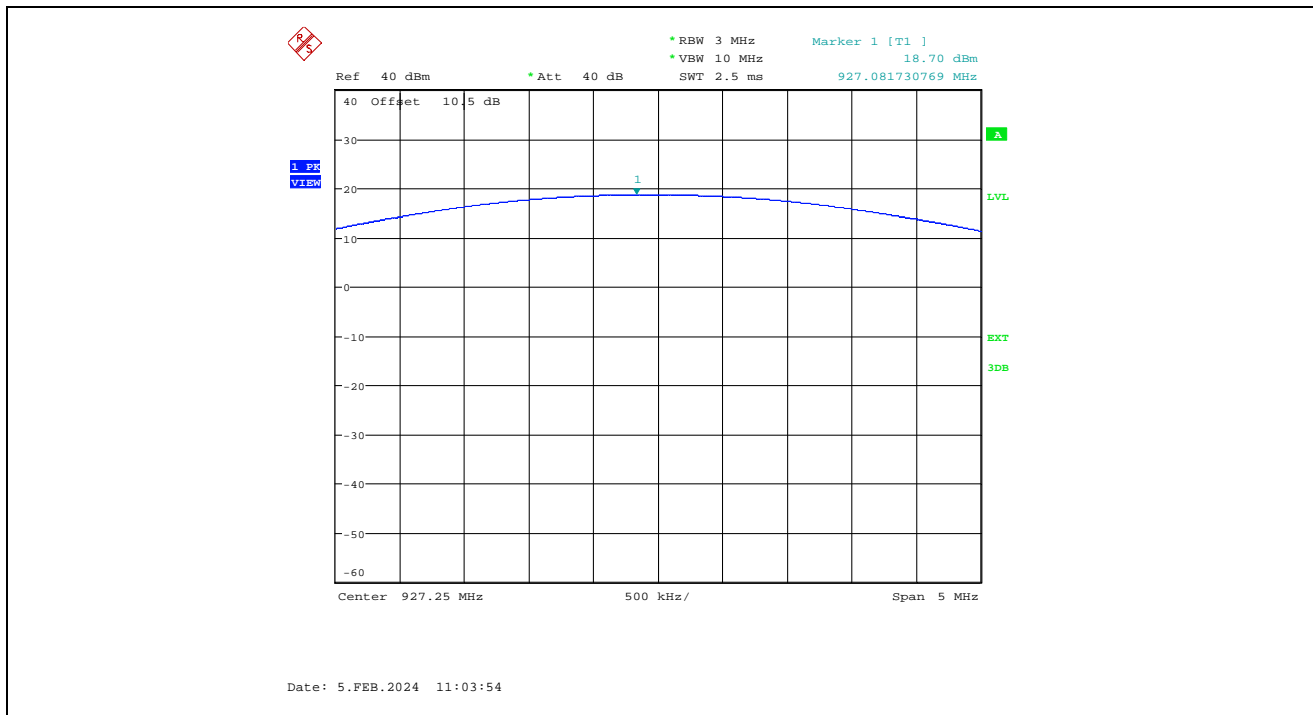

5.5. TRANSMITTER SPURIOUS RADIATED EMISSIONS AT 3 METERS [§§ 15.247(d), 15.209 & 15.205]

5.5.1. Limit

§ 15.247 (d): In any 100 kHz bandwidth outside the frequency band in which the spread spectrum or digitally modulated intentional radiator is operating, the radio frequency power that is produced by the intentional radiator shall be at least 20 dB below that in the 100 kHz bandwidth within the band that contains the highest level of the desired power, based on either an RF conducted or a radiated measurement, provided the transmitter demonstrates compliance with the peak conducted power limits. If the transmitter complies with the conducted power limits based on the use of RMS averaging over a time interval, as permitted under paragraph (b)(3) of this section, the attenuation required under this paragraph shall be 30 dB instead of 20 dB. Attenuation below the general limits specified in § 15.209(a) is not required. In addition, radiated emissions which fall in the restricted bands, as defined in § 15.205(a), must also comply with the radiated emission limits specified in § 15.209(a) (see § 15.205(c)).

Section 15.205(a) - Restricted Bands of Operation

MHz	MHz	MHz	GHz
0.090–0.110	16.42–16.423	399.9–410	4.5–5.15
¹ 0.495–0.505	16.69475–16.69525	608–614	5.35–5.46
2.1735–2.1905	16.80425–16.80475	960–1240	7.25–7.75
4.125–4.128	25.5–25.67	1300–1427	8.025–8.5
4.17725–4.17775	37.5–38.25	1435–1626.5	9.0–9.2
4.20725–4.20775	73–74.6	1645.5–1646.5	9.3–9.5
6.215–6.218	74.8–75.2	1660–1710	10.6–12.7
6.26775–6.26825	108–121.94	1718.8–1722.2	13.25–13.4
6.31175–6.31225	123–138	2200–2300	14.47–14.5
8.291–8.294	149.9–150.05	2310–2390	15.35–16.2
8.362–8.366	156.52475–156.52525	2483.5–2500	17.7–21.4
8.37625–8.38675	156.7–156.9	2655–2900	22.01–23.12
8.41425–8.41475	162.0125–167.17	3260–3267	23.6–24.0
12.29–12.293	167.72–173.2	3332–3339	31.2–31.8
12.51975–12.52025	240–285	3345.8–3358	36.43–36.5
12.57675–12.57725	322–335.4	3600–4400	(²)
13.36–13.41.			

¹ Until February 1, 1999, this restricted band shall be 0.490–0.510 MHz.

² Above 38.6

Section 15.209(a) - Radiated Emissions Limits; General Requirements

Frequency (MHz)	Field Strength (microvolts/meter)	Measurement Distance (meters)
0.009 - 0.490	2,400 / F (kHz)	300
0.490 - 1.705	24,000 / F (kHz)	30
1.705 - 30.0	30	30
30 – 88	100	3
88 – 216	150	3
216 – 960	200	3
Above 960	500	3

5.5.2. Method of Measurements

ANSI C63.10 and ANSI 63.4 procedures.

5.5.3. Test Arrangement

Band-Edge Radiated Emissions

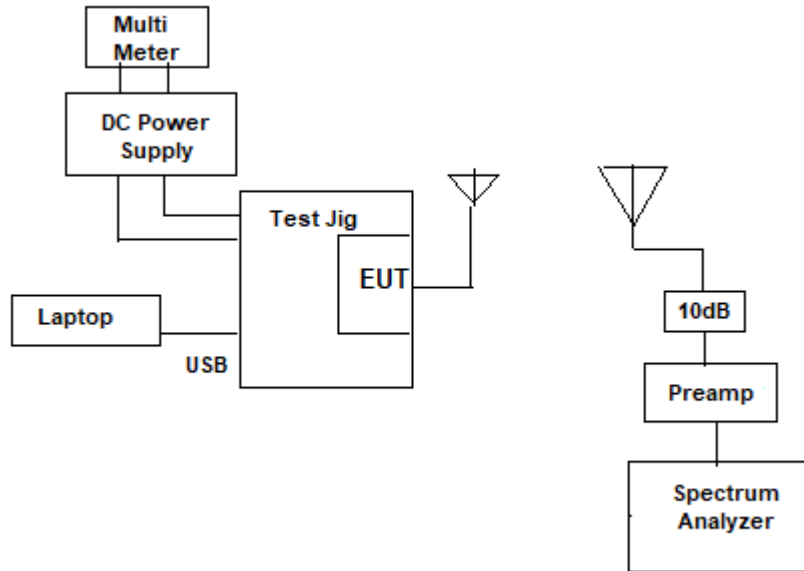

Radiated Spurious Emissions

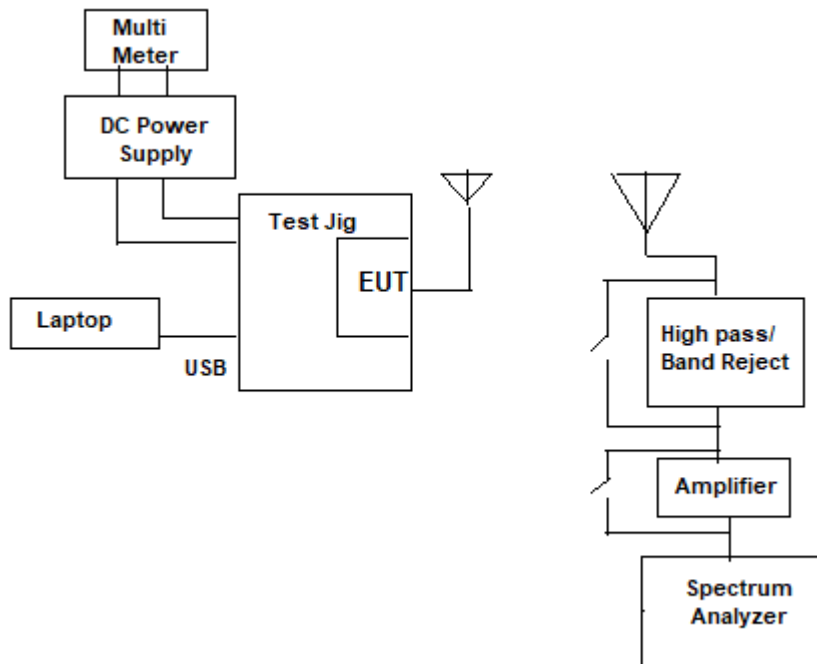

5.5.4. Test Data

Tests were performed on all product variants; refer to appendixes A to E for test results.

- 1 Appendix A for XB-9XR-DMUM-001;
- 2 Appendix B for XB-9XR-DMUS-001;
- 3 Appendix C for XB-9XR-DMUT-001;
- 4 Appendix D for XB-9XR-DMST-001 and
- 5 Appendix E for XB-9XR-DMCS-001

5.6. RF EXPOSURE REQUIRMENTS [§§ 15.247(i), 1.1310 & 2.1091]

§ 1.1310: The criteria listed in the following table shall be used to evaluate the environmental impact of human exposure to radio-frequency (RF) radiation as specified in 1.1307(b).

Limits for Maximum Permissible Exposure (MPE)

Frequency range (MHz)	Electric field strength (V/m)	Magnetic field strength (A/m)	Power density (mW/cm ²)	Averaging time (minutes)
(A) Limits for Occupational/Controlled Exposures				
0.3-3.0	614	1.63	*(100)	6
3.0-30	1842/f	4.89/f	*(900/f ²)	6
30-300	61.4	0.163	1.0	6
300-1500			f/300	6
1500-100,000			5	6
(B) Limits for General Population/Uncontrolled Exposure				
0.3-1.34	614	1.63	*(100)	30
1.34-30	824/f	2.19/f	*(180/f ²)	30
30-300	27.5	0.073	0.2	30
300-1500			f/1500	30
1500-100,000			1.0	30

f = frequency in MHz

* = Plane-wave equivalent power density

Note 1: Occupational/controlled limits apply in situations in which persons are exposed as a consequence of their employment provided those persons are fully aware of the potential for exposure and can exercise control over their exposure. Limits for occupational/controlled exposure also apply in situations when an individual is transient through a location where occupational/controlled limits apply provided he or she is made aware of the potential for exposure.

Note 2: General population/uncontrolled exposures apply in situations in which the general public may be exposed, or in which persons that are exposed as a consequence of their employment may not be fully aware of the potential for exposure or can not exercise control over their exposure.

5.6.1. Method of Measurements

Calculation Method of Power Density/RF Safety Distance:

$$S = \frac{PG}{4\pi \cdot r^2} = \frac{EIRP}{4\pi \cdot r^2}$$

- Where,
- P: power input to the antenna in mW
 - EIRP: Equivalent (effective) isotropic radiated power.
 - S: power density mW/cm²
 - G: numeric gain of antenna relative to isotropic radiator
 - r: distance to centre of radiation in cm

5.6.2. RF Evaluation

Frequency (MHz)	Tune-up Power (dBm)	Maximum Antenna Assembly Gain (dBi)	EIRP (dBm)	EIRP (mW)	Evaluation Distance, r (cm)	Power Density, S (mW/cm ²)	MPE Limit (mW/cm ²)	Margin (mW/cm ²)
902.5	19	14.48	33.48	2228.435	26	0.262	0.602	-0.340

EXHIBIT 6. TEST EQUIPMENT LIST

Test Instruments	Manufacturer	Model No.	Serial No.	Frequency Range	Cal. Due Date
Spectrum Analyzer	Agilent	E7401A	US40240432	9 kHz–22 GHz	06 Nov 2024
High Pass filter	Rohde & Schwarz	EZ-25	100064	Cut off 150kHz	09 Nov 2024
LISN Used	Schwarzbeck	NSLK 8127	8127276	9 kHz–30 MHz	13 Dec 2024
DC Power Supply	HQ Power	PS 613U	--	0-30Vdc	See Note 1
Multi-meter	Fluke	8842A	5436283	20mV - 1kV	28 Aug 2025
Spectrum Analyzer	Rohde & Schwarz	FSU26	200946	20Hz–26.5 GHz	11 Mar 2024
Spectrum Analyzer	Rohde & Schwarz	FSU26	100398	20Hz–26.5 GHz	21 Sep 2025
Attenuator	Hewlett Packard	8493C	0461	DC–26.5 GHz	See Note 1
Horn Antenna	ETS	3115	9701-5061	1-18GHz	09 Aug 2024
Preamp	Hewlett Packard	8449B	3003A00769	1000MHz-26.5GHz	08 Nov 2024
EMI Receiver	Rohde & Schwarz	ESU40	100037	20Hz–40 GHz	21 Sep 2024
Biconilog Antenna	EMCO	3142C	00026873	26-2000MHz	09 May 2024
Horn Antenna	ETS	3115	9701-5061	1-18GHz	09 Aug 2024
Preamp	Com-Power	PAM-118A	551052	500MHz-18GHz	06 Oct 2024
Preamp	Hewlett Packard	8449B	3003A00769	1000MHz-26.5GHz	08 Nov 2024
High Pass Filter	K & L	11SH10-1500/T8000	2	1.0 – 1.5GHz	See Note 1
Note 1: Internal Verification/Calibration Check					

* Equipment used before calibration due date.

EXHIBIT 7. MEASUREMENT UNCERTAINTY

The measurement uncertainties stated were calculated in accordance with the requirements of CISPR 16-4-2 @ IEC:2003 and JCGM 100:2008 (GUM 1995) – Guide to the Expression of Uncertainty in Measurement.

Test Description	Expanded Uncertainty, K=2 for 95% Confidence Level
Power Line Conducted Emissions	± 2.62
Occupied Bandwidth	± 0.20 Hz / ± 0.63 dB
Conducted Output Power	± 0.62 dB
Transmitter Spurious Radiated Emissions	± 4.20 dB (30 MHz – 1 GHz)
	± 2.70 dB (1 – 18 GHz)
Transmitter Radiated Band-edge Emissions	± 2.76 dB