

Test of Digi International, Rabbit MiniCore
RCM66XXW

To: FCC 47 CFR Part 15, SubPart C 15.247 &
RSS-210 Annex 8

Test Report Serial No.: DIGI25-U1 Rev A



TEST REPORT

From



Test of: Digi International, Rabbit MiniCore RCM66XXW

To: FCC 47 CFR Part 15, SubPart C 15.247 & RSS-210 Annex 8

Test Report Serial No.: DIGI25-U1 Rev A

This report supersedes: NONE

Applicant: Digi International
355 South 520 West, Suite 180
Lindon, Utah 84042
USA

Product Function: 802.11b,g Wireless Client

Copy No: pdf **Issue Date:** 29th February 2012

This Test Report is Issued Under the Authority of:

MiCOM Labs, Inc.
440 Boulder Court, Suite 200
Pleasanton, CA 94566 USA
Phone: +1 (925) 462-0304
Fax: +1 (925) 462-0306
www.micomlabs.com



TESTING CERTIFICATE #2381.01

MiCOM Labs is an ISO 17025 Accredited Testing Laboratory



TABLE OF CONTENTS

1	ACCREDITATION, LISTINGS & RECOGNITION	4
1.1	TESTING ACCREDITATION	4
1.2	RECOGNITION	5
1.3	PRODUCT CERTIFICATION	6
2	DOCUMENT HISTORY	7
3	TEST RESULT CERTIFICATE	8
4	REFERENCES AND MEASUREMENT UNCERTAINTY	9
4.1	Normative References	9
4.2	Test and Uncertainty Procedures	10
5	TEST SUMMARY	11
6	PRODUCT DETAILS AND TEST CONFIGURATIONS	12
6.1	Test Program Scope	12
6.2	EUT Details	15
6.3	External A.C. / D.C. Power Adaptor	16
6.4	Operational Power Range	16
6.5	Types of Modulation Supported	17
6.6	Antenna Details	17
6.7	Cabling and I/O Ports	17
6.8	EUT Configurations	18
6.9	Equipment Details	18
6.10	Test Configurations	18
6.11	Equipment Modifications	18
6.12	Deviations from the Test Standard	18
7	TEST RESULTS	19
7.1	6 dB and 99% Bandwidth	19
7.2	Peak Output Power	29
7.3	Maximum Permissible Exposure	34
7.4	Peak Power Spectral Density	35
7.5	Conducted Spurious Emissions	45
7.6	Radiated Spurious Emissions	61
7.7	Conducted Disturbance at Mains Terminal (150 kHz – 30 MHz)	82
8	Photographs	86
8.1	Conducted RF Emissions - EUT	86
8.2	Transmitter Radiated Spurious Emission above 1 GHz	87
8.3	Transmitter Radiated Spurious Emission below 1 GHz	88
9	TEST EQUIPMENT DETAILS	90

This test report may be reproduced in full only. The document may only be updated by MiCOM Labs personnel. Any changes will be noted in the Document History section of the report.

1 ACCREDITATION, LISTINGS & RECOGNITION

1.1 TESTING ACCREDITATION

MiCOM Labs, Inc. is an accredited Electrical testing laboratory per the international standard EN ISO/IEC 17025. The company is accredited by the American Association for Laboratory Accreditation (A2LA) www.a2la.org test laboratory number 2381.01. MiCOM Labs test schedule is available at the following URL; <http://www.a2la.org/scopepdf/2381-01.pdf>



The American Association for Laboratory Accreditation

World Class Accreditation

Accredited Laboratory

A2LA has accredited

MICOM LABS

Pleasanton, CA

for technical competence in the field of

Electrical Testing

This laboratory is accredited in accordance with the recognized International Standard ISO/IEC 17025:2005 *General Requirements for the Competence of Testing and Calibration Laboratories*. This accreditation demonstrates technical competence for a defined scope and the operation of a laboratory quality management system (refer to joint ISO-ILAC-IAF Communiqué dated 8 January 2009).

Presented this 14th day of April 2010.



President & CEO
For the Accreditation Council
Certificate Number 2381.01
Valid to March 31, 2012
Revised January 20, 2012

For the tests or types of tests to which this accreditation applies, please refer to the laboratory's Electrical Scope of Accreditation.

This test report may be reproduced in full only. The document may only be updated by MiCOM Labs personnel. Any changes will be noted in the Document History section of the report.



1.2 RECOGNITION

MiCOM Labs, Inc has widely recognized Electrical testing capabilities. Our international recognition includes Conformity Assessment Body designation by APEC MRA** countries. Our test reports are widely accepted for global type approvals.

Country	Recognition Body	Status	Phase	Identification No.
USA	Federal Communications Commission (FCC)	TCB	-	Listing #: 102167
Canada	Industry Canada (IC)	FCB	APEC MRA 2	Listing #: 4143A
Japan	VCCI	CAB	210	No. 2959
Europe	European Commission	NB	EU MRA	NB 2280
Australia	Australian Communications and Media Authority (ACMA)	CAB	APEC MRA 1	US0159
Hong Kong	Office of the Telecommunication Authority (OFTA)	CAB	APEC MRA 1	
Korea	Ministry of Information and Communication Radio Research Laboratory (RRL)	CAB	APEC MRA 1	
Singapore	Infocomm Development Authority (IDA)	CAB	APEC MRA 1	
Taiwan	National Communications Commission (NCC) Bureau of Standards, Metrology and Inspection (BSMI)	CAB	APEC MRA 1	
Vietnam	Ministry of Communication (MIC)	CAB	APEC MRA 1	

**APEC MRA – Asia Pacific Economic Community Mutual Recognition Agreement.

Is a recognition agreement under which test lab is accredited to regulatory standards of the APEC member countries.

Phase I - recognition for product testing

Phase II – recognition for both product testing and certification

N/A – Not Applicable

**EU MRA – European Union Mutual Recognition Agreement.

Is a recognition agreement under which test lab is accredited to regulatory standards of the EU member countries.

**NB – Notified Body

This test report may be reproduced in full only. The document may only be updated by MiCOM Labs personnel. Any changes will be noted in the Document History section of the report.



Title: Rabbit MiniCore RCM66XXW
To: FCC 47 CFR Part 15.247 & RSS-210
Serial #: DIGI25-U1 Rev A
Issue Date: 29th February 2012
Page: Page 6 of 91

1.3 PRODUCT CERTIFICATION

MiCOM Labs, Inc. is an accredited Product Certification Body per the international standard EN ISO/IEC Guide 65. The company is accredited by the American Association for Laboratory Accreditation (A2LA) www.a2la.org test laboratory number 2381.02. MiCOM Labs test schedule is available at the following URL; <http://www.a2la.org/scopepdf/2381-02.pdf>



The American Association for Laboratory Accreditation

World Class Accreditation

Accredited Product Certification Body

A2LA has accredited

MICOM LABS

Pleasanton, CA

for technical competence as a

Product Certification Body

This product certification body is accredited in accordance with the recognized International Standard ISO/IEC Guide 65:1996 *General requirements for bodies operating product certification systems*. This accreditation demonstrates technical competence for a defined scope and the operation of a quality management system for a Telecommunications Certification Body (TCB) meeting FCC (U.S.), Japan (MIC), and IC (Canada) requirements.



Presented this 24th day of June 2010.

President & CEO
For the Accreditation Council
Certificate Number 2381.02
Valid to March 31, 2012
Revised January 20, 2012

For the product certification schemes to which this accreditation applies, please refer to the organization's Product Certification Scope of Accreditation.

United States of America – Telecommunication Certification Body (TCB)

TCB Identifier – US0159

Industry Canada – Certification Body

CAB Identifier – US0159

Europe – Notified Body

Notified Body Identifier - 2280

Japan – Recognized Certification Body (RCB)

RCB Identifier - 210

This test report may be reproduced in full only. The document may only be updated by MiCOM Labs personnel. Any changes will be noted in the Document History section of the report.



Title: Rabbit MiniCore RCM66XXW
To: FCC 47 CFR Part 15.247 & RSS-210
Serial #: DIGI25-U1 Rev A
Issue Date: 29th February 2012
Page: Page 7 of 91

2 DOCUMENT HISTORY

Document History		
Revision	Date	Comments
Draft		
Rev A	29 th February 2012	Initial Release

This test report may be reproduced in full only. The document may only be updated by MiCOM Labs personnel. Any changes will be noted in the Document History section of the report.



Title: Rabbit MiniCore RCM66XXW
To: FCC 47 CFR Part 15.247 & RSS-210
Serial #: DIGI25-U1 Rev A
Issue Date: 29th February 2012
Page: Page 8 of 91

3 TEST RESULT CERTIFICATE

Applicant:	Digi International 355 South 520 West Suite 180 California 94304 USA	Tested By:	MiCOM Labs, Inc. 440 Boulder Court Suite 200 Pleasanton California, 94566, USA
Product:	2.4 GHz WiFi Client	Telephone:	+1 925 462 0304
Model No.:	RCM66XXW	Fax:	+1 925 462 0306
S/No's:	Not Provided		
Date(s) Tested:	31 st Jan – 12 th February 2012	Website:	www.micomlabs.com

STANDARD(S)	TEST RESULTS
FCC 47 CFR Part 15, SubPart C 15.247 & RSS-210 Annex 8	EQUIPMENT COMPLIES

MiCOM Labs, Inc. tested the equipment mentioned in accordance with the requirements set forth in the above standards. Test results indicate that the equipment tested is capable of demonstrating compliance with the requirements as documented within this report.

Notes:

1. This document reports conditions under which testing was conducted and the results of testing performed.
2. Details of test methods used have been recorded and kept on file by the laboratory.
3. Test results apply only to the item(s) tested.

Approved & Released for MiCOM Labs, Inc. by:



TESTING CERTIFICATE #2381.01



Graeme Grieve
Quality Manager MiCOM Labs, Inc.

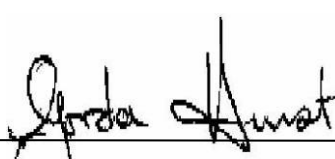

Gordon Hurst
President & CEO MiCOM Labs, Inc.

This test report may be reproduced in full only. The document may only be updated by MiCOM Labs personnel. Any changes will be noted in the Document History section of the report.

4 REFERENCES AND MEASUREMENT UNCERTAINTY

4.1 Normative References

Ref.	Publication	Year	Title
i.	FCC 47 CFR Part 15, SubPart C 15.247	2010	Title 47: Telecommunication PART 15—RADIO FREQUENCY DEVICES Subpart C—Intentional Radiators
ii.	RSS-210 Annex 8	2010	Radio Standards Specification 210, Issue 8, Low-power Licence-exempt Radiocommunication Devices (All Frequency Bands): Category I Equipment,
iii.	RSS-GEN	2010	Radio Standards Specification-Gen, Issue 3, General Requirements and Information for the Certification of Radiocommunication Equipment,
iv.	47 CFR Part 15, SubPart B	2010	47 CFR Part 15, SubPart B; Unintentional Radiators
v.	ICES-003	2004	Spectrum Management and Telecommunications Policy Interference-Causing Equipment Standard Digital Apparatus; Issue 4
vi.	ANSI C63.4	2009	American National Standards for Methods of Measurement of Radio-Noise Emissions from Low-Voltage Electrical and Electronic Equipment in the Range of 9 kHz to 40 GHz
vii.	CISPR 22/ EN 55022	2008 2006+A1:2007	Limits and Methods of Measurements of Radio Disturbance Characteristics of Information Technology Equipment
viii.	M 3003	Edition 1 Dec. 1997	Expression of Uncertainty and Confidence in Measurements
ix.	LAB34	Edition 1 Aug 2002	The expression of uncertainty in EMC Testing
x.	ETSI TR 100 028	2001	Parts 1 and 2 Electromagnetic compatibility and Radio Spectrum Matters (ERM); Uncertainties in the measurement of mobile radio equipment characteristics
xi.	A2LA	9th June 2010	Reference to A2LA Accreditation Status – A2LA Advertising Policy

This test report may be reproduced in full only. The document may only be updated by MiCOM Labs personnel. Any changes will be noted in the Document History section of the report.



Title: Rabbit MiniCore RCM66XXW
To: FCC 47 CFR Part 15.247 & RSS-210
Serial #: DIGI25-U1 Rev A
Issue Date: 29th February 2012
Page: Page 10 of 91

4.2 Test and Uncertainty Procedures

Conducted and radiated emission measurements were conducted in accordance with American National Standards Institute ANSI C63.4, listed in the Normative References section of this report.

Measurement uncertainty figures are calculated in accordance with ETSI TR 100 028 Parts 1 and 2.

Measurement uncertainties stated are based on a standard uncertainty multiplied by a coverage factor $k = 2$, providing a level of confidence of approximately 95 % in accordance with UKAS document M 3003 listed in the Normative References section of this report.

This test report may be reproduced in full only. The document may only be updated by MiCOM Labs personnel. Any changes will be noted in the Document History section of the report.



5 TEST SUMMARY

List of Measurements: The following table represents the list of measurements required under FCC 47 CFR Part 15, SubPart C 15.247 & industry Canada RSS-210 Annex 8.

Standard Section(s)	Test Description	Condition	Result	Notes	Test Report Section
15.247 (a)(2)	6 dB Occupied Bandwidth	Conducted	PASS	Note 1,2,3	7.1
15.247 (b)(3), 15.247 (b)(4)	Peak Output Power	Conducted	PASS	Note 1,2,3	7.2
15.247 (i)	Maximum Permissible Exposure	Calculation	PASS	Note 1,2,3	7.3
15.247 (e)	Peak Power Spectral Density	Conducted	PASS	Note 1,2,3	7.4
15.247 (d)	Spurious Emissions	Conducted	PASS	Note 1,2,3	7.5
15.247 (d), 15.205, 15.209	Transmitter Radiated Spurious Emissions	Radiated	PASS	Note 1,2,3	7.6.1
15.247 (d), 15.205, 15.209	Radiated Band-Edge	Radiated	PASS	Note 1,2,3	7.6.2
RSS-GEN	Radiated Peak Emissions	Radiated	PASS	Note 1,2,3	7.6.3
RSS-GEN	Radiated Receiver Emissions	Radiated	PASS	Note 1,2,3	7.6.4
15.207	AC Wireline Emissions 0.15 – 30 MHz	Conducted		Not Tested – EUT Module Battery Powered	7.7

Note 1: Test results reported in this document relate only to the items tested

Note 2: The required tests demonstrated compliance as per client declaration of test configuration, monitoring methodology and associated pass/fail criteria

Note 3: Section 6.11 Equipment Modifications highlights the equipment modifications that were required to bring the product into compliance with the above test matrix



6 PRODUCT DETAILS AND TEST CONFIGURATIONS

6.1 Test Program Scope

The scope of the test program was to test the 802.11b/g Wi-Fi Client for compliance against FCC 47 CFR Part 15, SubPart C 15.247 & RSS-210 Annex 8.

Brand	Product Name	Model #	Part #	Description
Digi International	802.11 b/g WiFi Module	RCM6600W	20-101-1322	Wi-Fi module with 1 MByte serial flash
Digi International	802.11 b/g WiFi Module	RCM6650W	20-101-1323	Wi-Fi module with 4 MByte serial flash

The only difference between the modules is the capacity of the serial flash (1 MByte vs. 4 MByte)



Title: Rabbit MiniCore RCM66XXW
To: FCC 47 CFR Part 15.247 & RSS-210
Serial #: DIGI25-U1 Rev A
Issue Date: 29th February 2012
Page: Page 13 of 91

APPLICANT: Digi International

PRODUCT: 2.4 GHz Wi-Fi Client

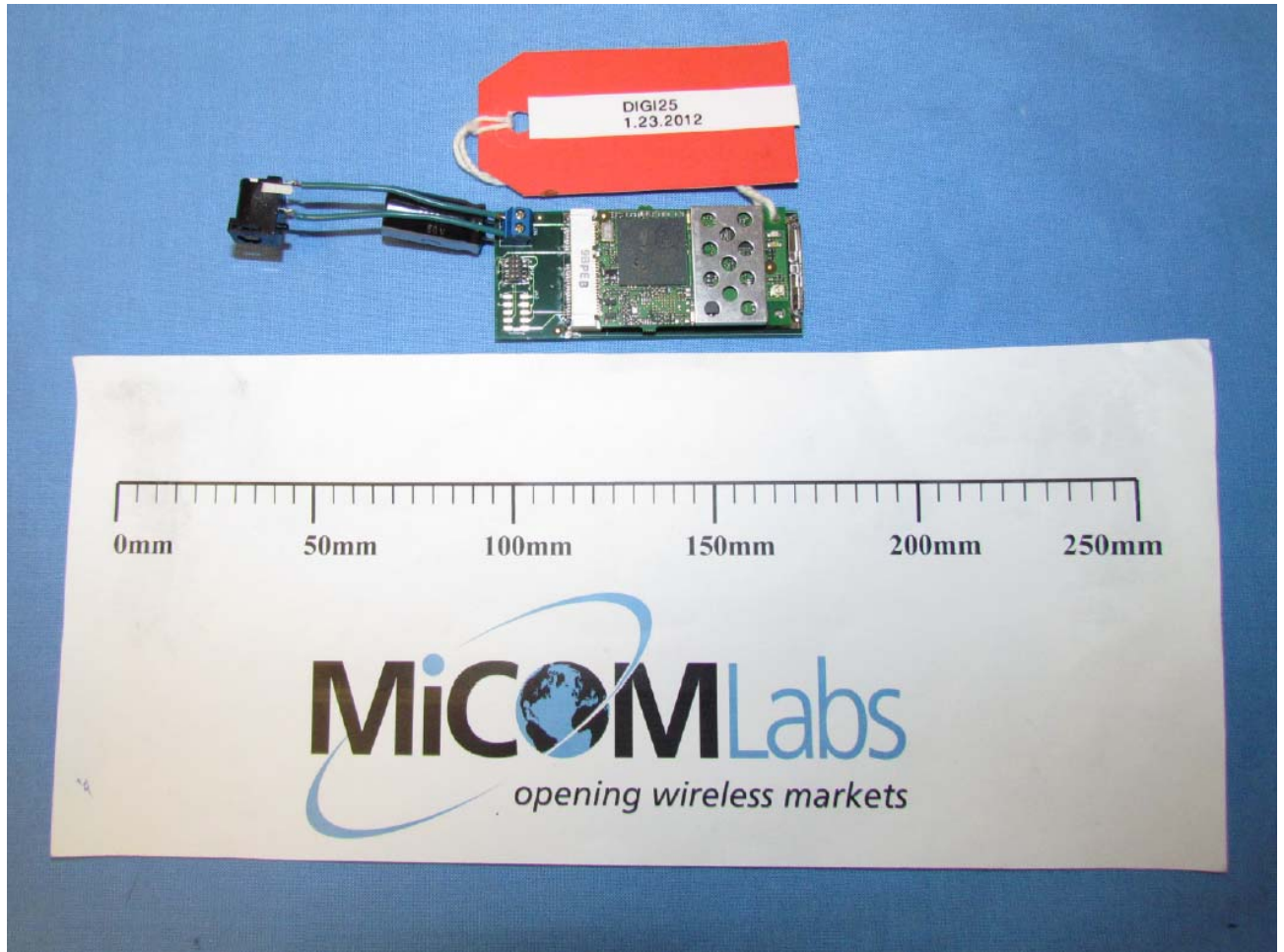

This test report may be reproduced in full only. The document may only be updated by MiCOM Labs personnel. Any changes will be noted in the Document History section of the report.

APPLICANT: Digi International

PRODUCT: 2.4 GHz Wi-Fi Client – Module underside

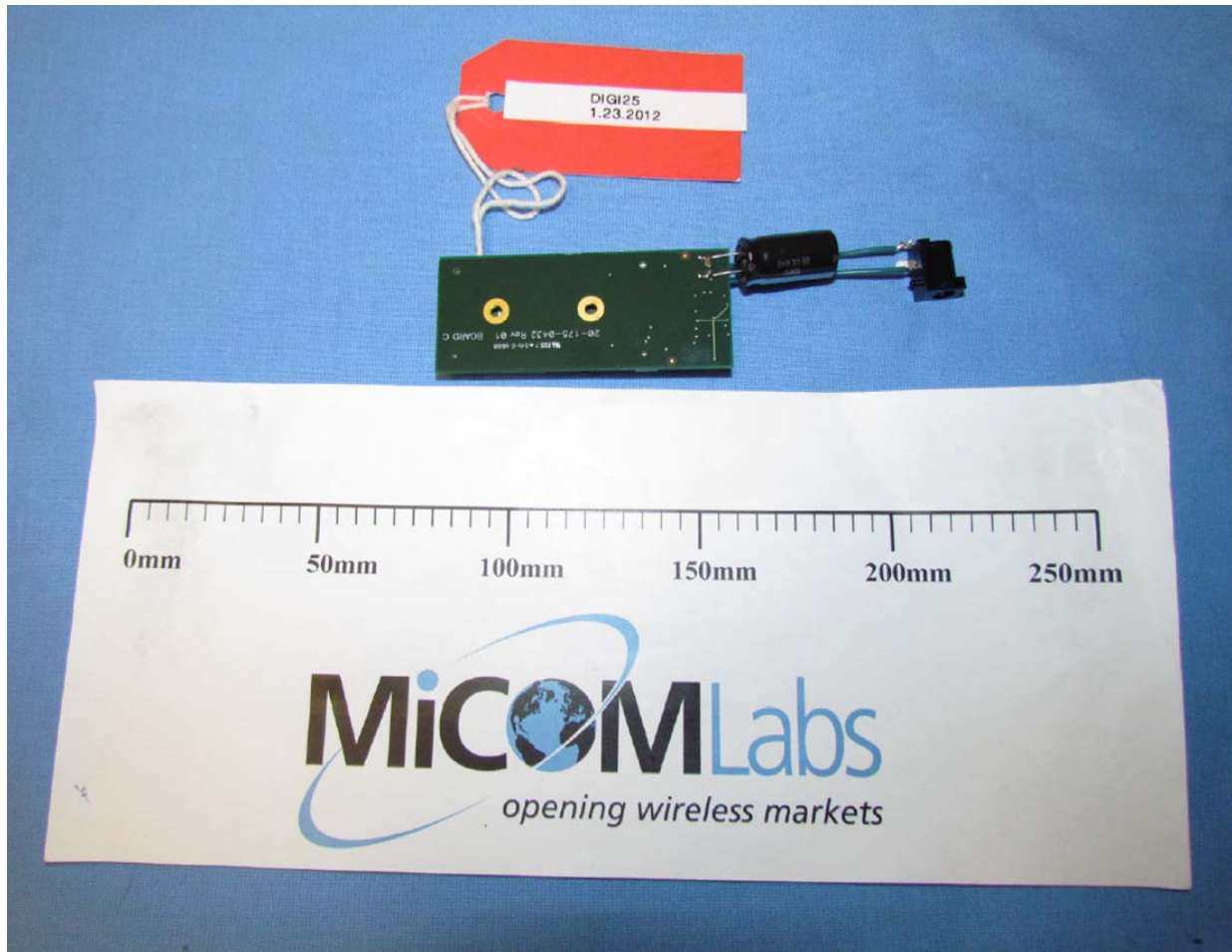

This test report may be reproduced in full only. The document may only be updated by MiCOM Labs personnel. Any changes will be noted in the Document History section of the report.



Title: Rabbit MiniCore RCM66XXW
To: FCC 47 CFR Part 15.247 & RSS-210
Serial #: DIGI25-U1 Rev A
Issue Date: 29th February 2012
Page: Page 15 of 91

6.2 EUT Details

Detail	Description
Purpose:	Test of the Digi International 2.4 GHz Wi-Fi Client RCM66XXW for compliance against FCC 47 CFR Part 15, SubPart C 15.247 & RSS-210 Annex 8
Applicant:	Digi International 355 South 520 West Suite 180 California 94304 USA
Manufacturer:	As Applicant
Test Laboratory:	MiCOM Labs, Inc. 440 Boulder Court, Suite 200 Pleasanton, California 94566 USA
Test report reference number:	DIGI25-U1
Date EUT received:	24th January 2012
Dates of test (from - to):	31st Jan – 12th February 2012
No of Units Tested:	1
Product Name:	802.11 b/g Embedded WiFi Module
Manufacturers Trade Name:	Digi International
Model No.:	RCM66XXW
Part numbers:	RCM6600W and RCM6650W
Equipment Primary Function:	Wi-Fi client module for use in customer hardware designs
Equipment Secondary Function(s):	Not provided
Type of Technology:	802.11b/g
Installation type:	Mobile
Construction/Location for Use:	Indoor/Outdoor
Hardware Release:	Rev. A
Software/Firmware Release:	10.70
Rated Input Voltage and Current DC:	Powered by Host Nominal:3.3 Vdc; Extremes: 3.1 – 3.6 Vdc
Operating Temperature Range °C:	Min: -40 °C Max: +85 °C
Equipment Dimensions:	2.006 X 1.181 X 0.184 in
Weight:	Not provided
ITU Emission Designator:	2400 – 2483.5 MHz 802.11b - 15M2G1D 2400 – 2483.5 MHz 802.11g - 16M6D1D
Transmit/Receive Operation:	Full Duplex
Output Power Type	Fixed

This test report may be reproduced in full only. The document may only be updated by MiCOM Labs personnel. Any changes will be noted in the Document History section of the report.



Title: Rabbit MiniCore RCM66XXW
To: FCC 47 CFR Part 15.247 & RSS-210
Serial #: DIGI25-U1 Rev A
Issue Date: 29th February 2012
Page: Page 16 of 91

6.3 External A.C. / D.C. Power Adaptor

1. NONE – EUT dc powered

Model	Description

6.4 Operational Power Range

Power reduction was required as a result of radiated band-edge and power spectra density issues. The results presented in Section 7.2 Peak Output Power take this reduction into account.

This test report may be reproduced in full only. The document may only be updated by MiCOM Labs personnel. Any changes will be noted in the Document History section of the report.



Title: Rabbit MiniCore RCM66XXW
To: FCC 47 CFR Part 15.247 & RSS-210
Serial #: DIGI25-U1 Rev A
Issue Date: 29th February 2012
Page: Page 17 of 91

6.5 Types of Modulation Supported

Modulation / Mode	BW 1
802.11b	DSSS/CCK
802.11g	OFDM

6.6 Antenna Details

The following is a description of the EUT antennas.

Antenna Type	Manufacturer	Model	Gain (dBi)	Frequency Range
Dipole	Bobbintron Electrical Corporation	SA-006-1	1.8	2400-2500

6.7 Cabling and I/O Ports

The following is a description of the cable and input, output ports available on the EUT.

1. NONE – module had no external cabling or I/O ports

Type of I/O Ports	Description	Screened (Y/N)	Length	Qty	Tested (Y/N)
RF Port	U.FL antenna connector				
DC Supply	No cable direct connection	--	--	1	N
I/O Port	No cable direct connection	--	--	1	N

This test report may be reproduced in full only. The document may only be updated by MiCOM Labs personnel. Any changes will be noted in the Document History section of the report.



6.8 EUT Configurations

Channel plan and spacing

Band (GHz)	Mode	Freq Band (MHz)	Freq Range (MHz)	Low Ch	Mid Ch	High Ch	# Ch	Ch Spacing (MHz)
2.4	802.11b	2400-2483.5	2412 - 2462	2412	2437	2462	11	5
2.4	802.11g	2400-2483.5	2412 - 2462	2412	2437	2462	11	5

6.9 Equipment Details

The following is a description of supporting equipment used during the test program.

Equipment	Equipment Description	Manufacturer	Model No.	Serial No (s).	Tested
Computer	Laptop	IBM			

6.10 Test Configurations

Operational Mode(s)	Data Rate Tested	Duty Cycle
b	1 MBit/s	100 %
g	6 MBit/s	100 %

6.11 Equipment Modifications

The following modifications were required to bring the equipment into compliance:

1. NONE

6.12 Deviations from the Test Standard

The following deviations from the test standard were required in order to complete the test program:

1. NONE

7 TEST RESULTS

7.1 6 dB and 99% Bandwidth

Test Procedure

The test methodology and conditions utilized for each measurement is referenced in the following test results matrix. 6 dB and 99% bandwidth were measured per the Test Configuration identified below.

Testing was restricted to a single port.

Test Configuration

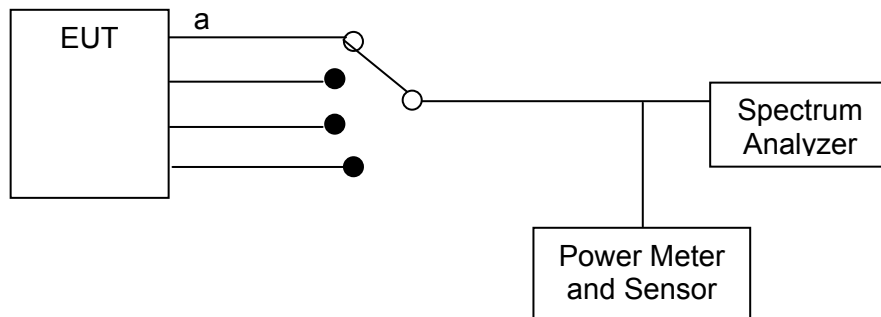

Test setup for 6 dB & 99% Bandwidth



Specification for 6dB Bandwidth Limits

FCC §15.247 (a)(2)

The minimum 6 dB bandwidth shall be at least 500 kHz.

Industry Canada RSS-210 §A8.2 (a)

These include systems that employ digital modulation techniques resulting in spectral characteristics similar to direct sequence systems. The following applies to all three bands:

(a) The minimum -6 dB bandwidth shall be at least 500 kHz.

Traceability

Method	Test Equipment Used
WI-03	0158, 0252, 0313, 0314, 0116, 0117, 0287, 0363

This test report may be reproduced in full only. The document may only be updated by MiCOM Labs personnel. Any changes will be noted in the Document History section of the report.



Title: Rabbit MiniCore RCM66XXW
To: FCC 47 CFR Part 15.247 & RSS-210
Serial #: DIGI25-U1 Rev A
Issue Date: 29th February 2012
Page: Page 21 of 91

7.1.1 6 dB and 99% Bandwidth Results: 802.11b

Test Conditions:	15.247 (a)(2)	Rel. Humidity (%):	35 to 42
Variant:	802.11b	Ambient Temp. (°C):	19 to 22
TPC:	HIGH	Pressure (mBars):	998 to 1003
Modulation:	ON	Duty Cycle (%):	100
Beam Forming Gain (Y):	N/A dB	Antenna Gain:	1.8 dBi
Applied Voltage:	3.30 Vdc		
Notes 1:			
Notes 2:			

6 dB Bandwidth

Test Frequency	6 dB Bandwidth				Minimum 6dB Bandwidth Limit		Margin
	MHz				kHz	MHz	
MHz	a	b	c	d			
2412.000	10.100000	--	--	--	500	0.5	-9.600000
2437.000	10.100000	--	--	--			-9.600000
2462.000	10.100000	--	--	--			-9.600000

99% Bandwidth

Test Frequency	99 % Bandwidth						
	MHz						
MHz	a	b	c	d			
2412.000	14.990000	--	--	--			
2437.000	15.150000	--	--	--			
2462.000	14.990000	--	--	--			

Measurement uncertainty:	±2.81 dB
---------------------------------	----------

This test report may be reproduced in full only. The document may only be updated by MiCOM Labs personnel. Any changes will be noted in the Document History section of the report.

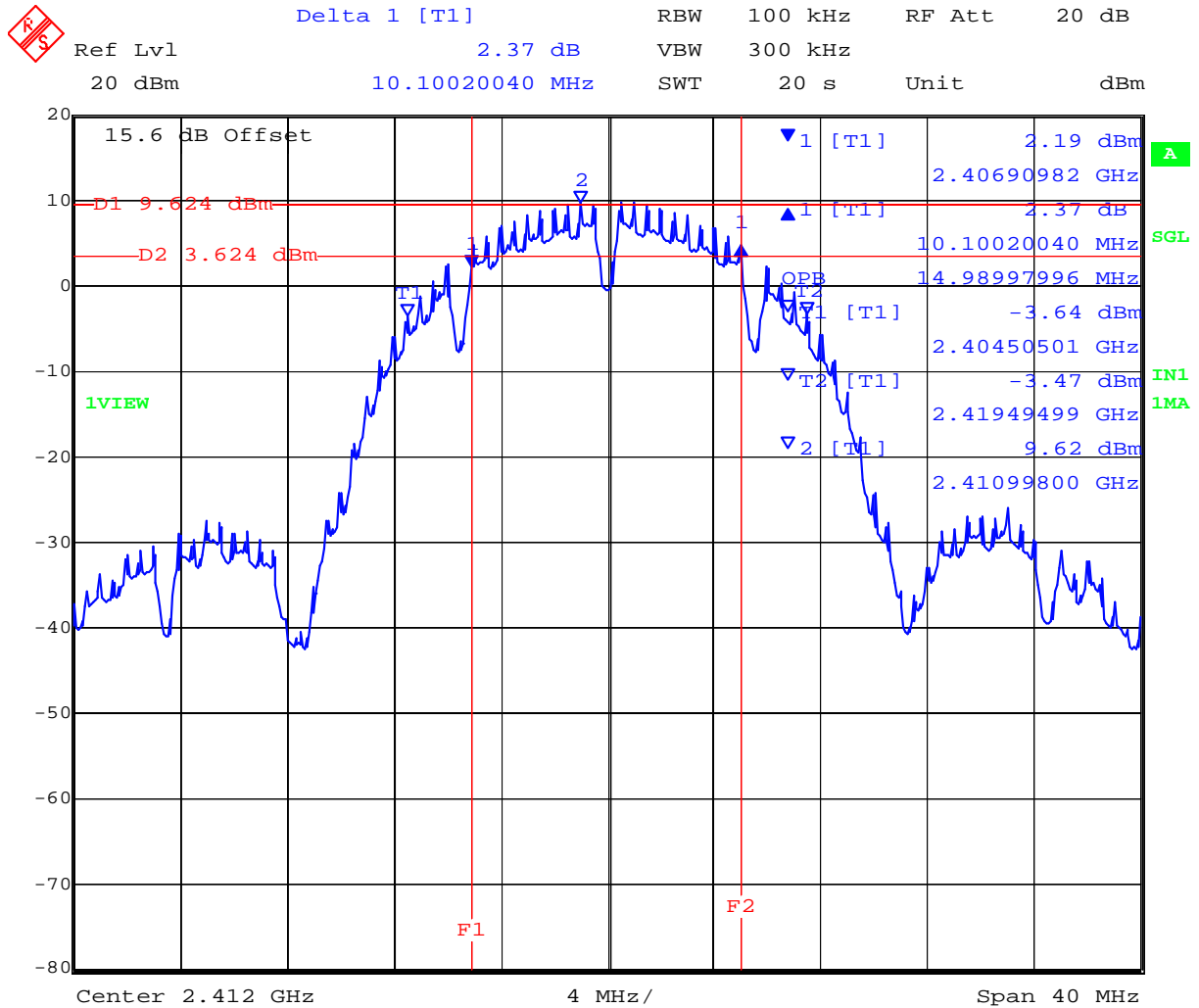

Date: 31.JAN.2012 14:42:43

This test report may be reproduced in full only. The document may only be updated by MiCOM Labs personnel. Any changes will be noted in the Document History section of the report.



Title: Rabbit MiniCore RCM66XXW
To: FCC 47 CFR Part 15.247 & RSS-210
Serial #: DIGI25-U1 Rev A
Issue Date: 29th February 2012
Page: Page 23 of 91

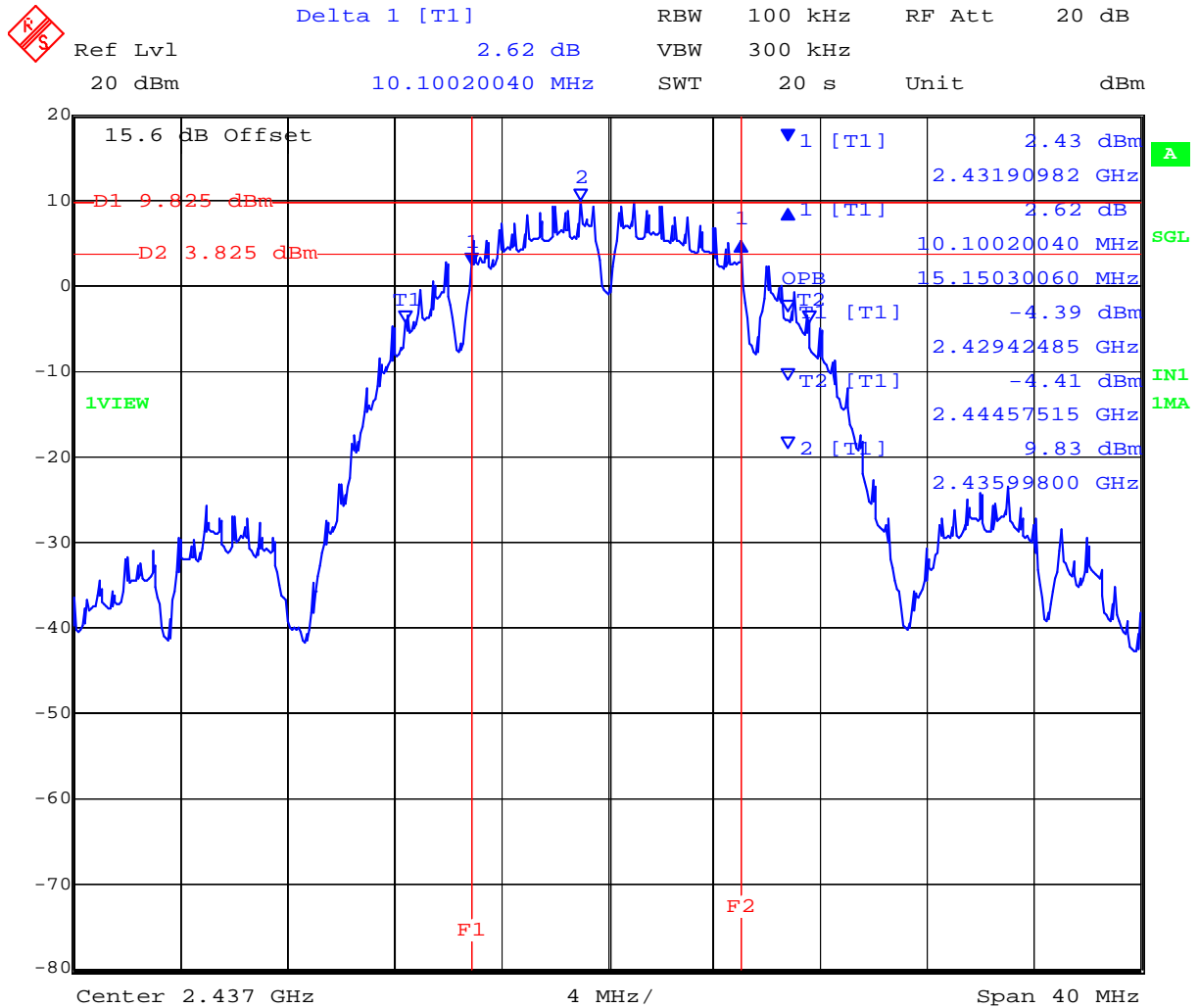

Date: 31.JAN.2012 14:56:35

This test report may be reproduced in full only. The document may only be updated by MiCOM Labs personnel. Any changes will be noted in the Document History section of the report.

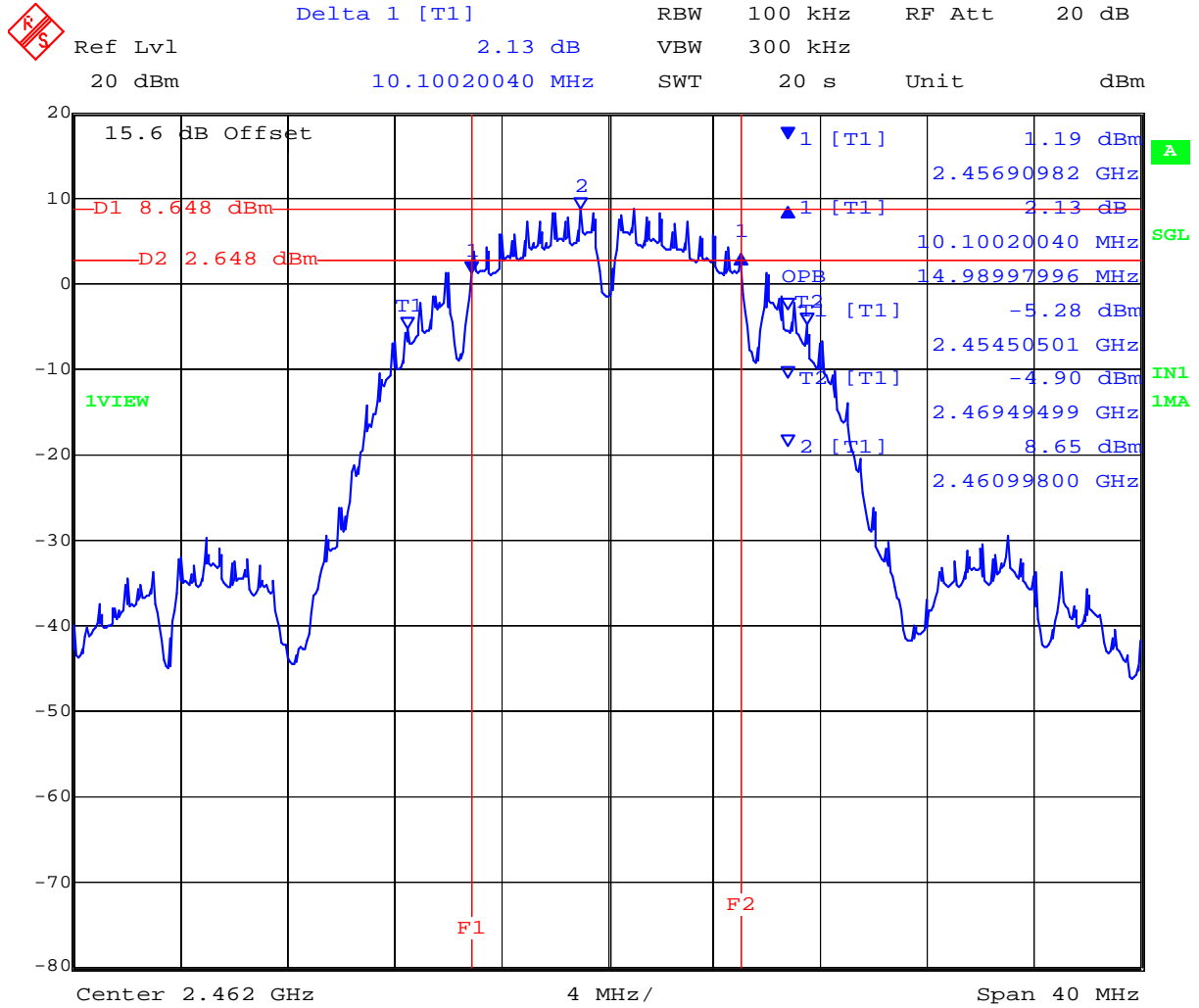

Date: 31.JAN.2012 15:29:43

This test report may be reproduced in full only. The document may only be updated by MiCOM Labs personnel. Any changes will be noted in the Document History section of the report.



Title: Rabbit MiniCore RCM66XXW
To: FCC 47 CFR Part 15.247 & RSS-210
Serial #: DIGI25-U1 Rev A
Issue Date: 29th February 2012
Page: Page 25 of 91

7.1.2 6 dB and 99% Bandwidth Results: 802.11g

Test Conditions:	15.247 (a)(2)	Rel. Humidity (%):	35 to 42
Variant:	802.11g	Ambient Temp. (°C):	19 to 22
TPC:	HIGH	Pressure (mBars):	998 to 1003
Modulation:	ON	Duty Cycle (%):	100
Beam Forming Gain (Y):	N/A dB	Antenna Gain:	1.8 dBi
Applied Voltage:	3.30 Vdc		
Notes 1:			
Notes 2:			

6 dB Bandwidth

Test Frequency	6 dB Bandwidth				Minimum 6dB Bandwidth Limit		Margin
	MHz				kHz	MHz	
MHz	a	b	c	d			
2412.000	16.673000	--	--	--	500	0.5	-16.173000
2437.000	16.673000	--	--	--			-16.173000
2462.000	16.673000	--	--	--			-16.173000

99% Bandwidth

Test Frequency	99 % Bandwidth					
	MHz					
MHz	a	b	c	d		
2412.000	16.593000	--	--	--		
2437.000	16.593000	--	--	--		
2462.000	16.593000	--	--	--		

Measurement uncertainty:	±2.81 dB
---------------------------------	----------

This test report may be reproduced in full only. The document may only be updated by MiCOM Labs personnel. Any changes will be noted in the Document History section of the report.

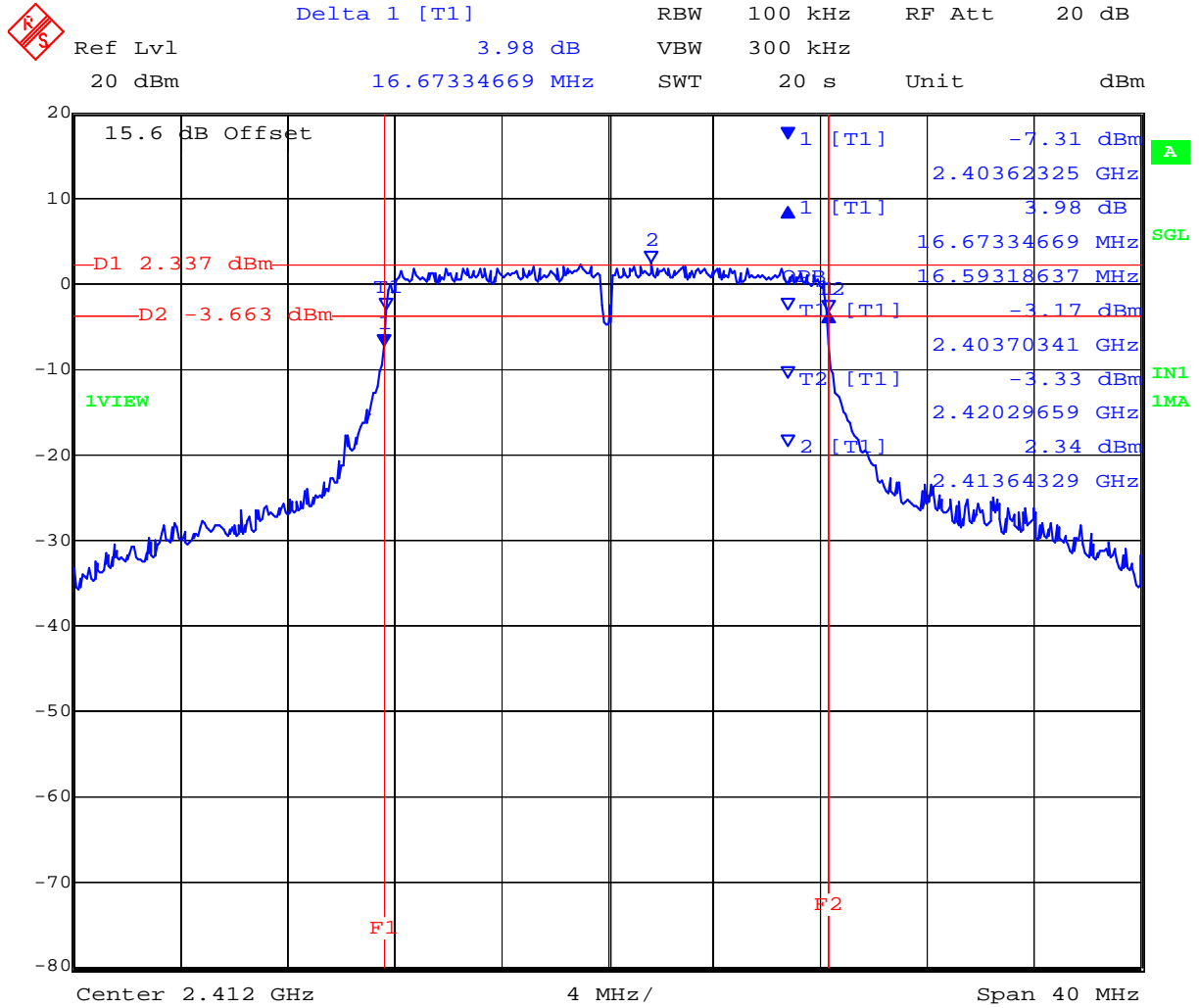

Date: 31.JAN.2012 16:13:21

This test report may be reproduced in full only. The document may only be updated by MiCOM Labs personnel. Any changes will be noted in the Document History section of the report.

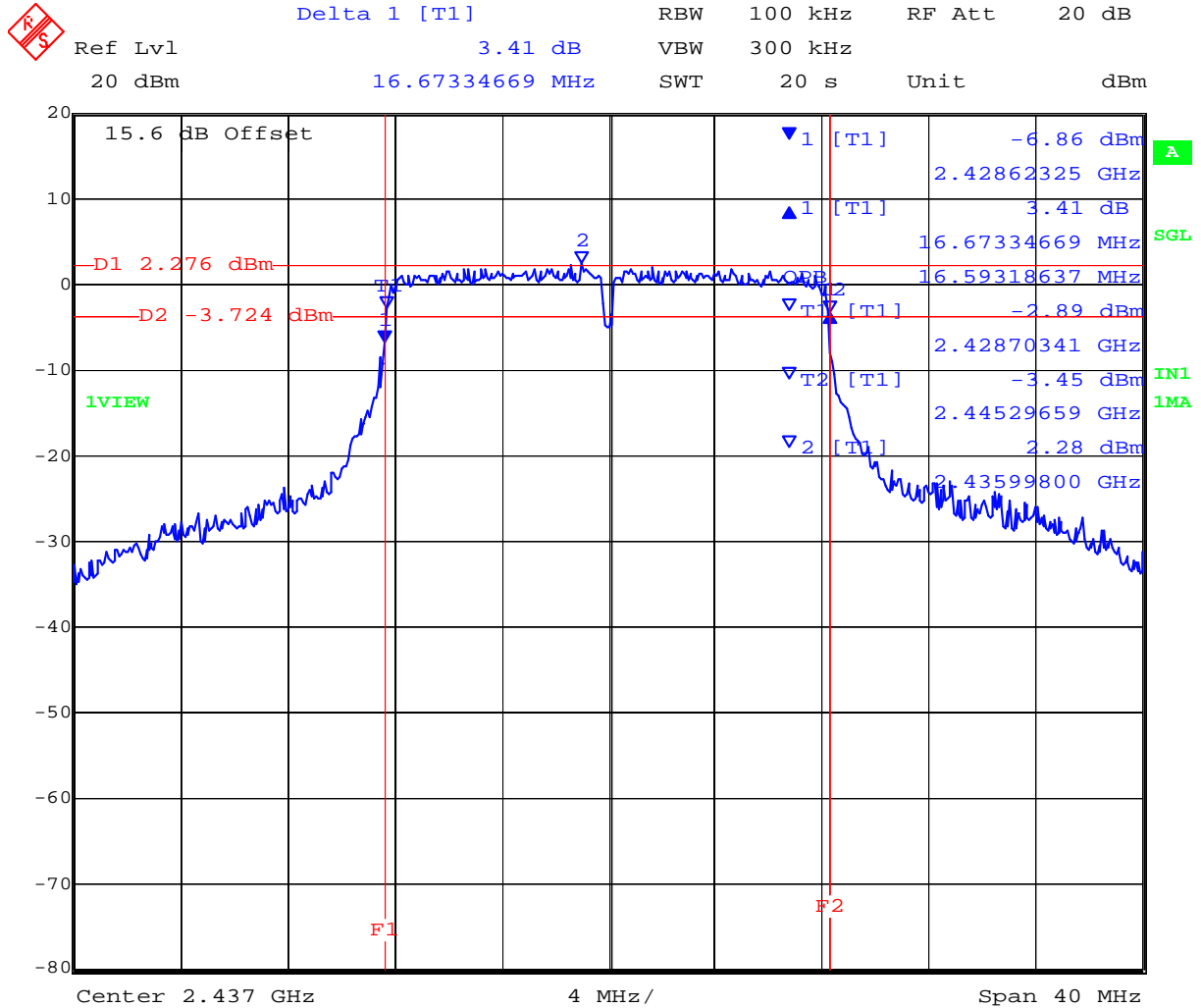

Date: 31.JAN.2012 16:30:28

This test report may be reproduced in full only. The document may only be updated by MiCOM Labs personnel. Any changes will be noted in the Document History section of the report.

7.2 Peak Output Power

Test Procedure

The test methodology and conditions utilized for each measurement is referenced in the test results matrix. The average output power was measured per the test configuration identified below. Per the standard measurements were taken at ambient conditions, nominal voltage.

Test Configuration

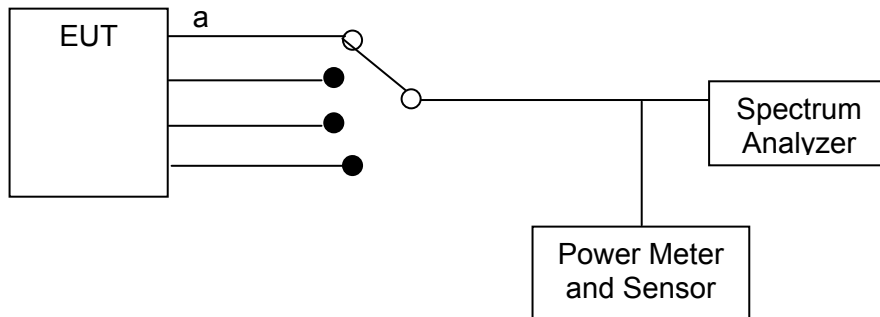

Measurement setup for Peak Output Power



Title: Rabbit MiniCore RCM66XXW
To: FCC 47 CFR Part 15.247 & RSS-210
Serial #: DIGI25-U1 Rev A
Issue Date: 29th February 2012
Page: Page 30 of 91

Specification for Peak Output Power Limits

§15.247 (b) The maximum peak output power of the intentional radiator shall not exceed the following:

§15.247 (b) (3) For systems using digital modulation in the 902-928 MHz, 2400-2483.5 MHz and 5725-5850 MHz bands: 1.0 watt.

15.247 (b) (4) The conducted output power limit specified in paragraph (b) of this section is based on the use of antennas with directional gains that do not exceed 6 dBi. Except as shown in paragraph (c) of this section, if transmitting antennas of directional gain greater than 6 dBi are used, the conducted output power from the intentional radiator shall be reduced below the stated values in paragraphs (b)(1), (b)(2), and (b)(3) of this section, as appropriate, by the amount in dB that the directional gain of the antenna exceeds 6 dBi.

15.247 (c) Operation with directional antenna gains greater than 6 dBi.

(1) Fixed point-to-point operation:

(i) Systems operating in the 2400–2483.5 MHz band that are used exclusively for fixed, point-to-point operations may employ transmitting antennas with directional gain greater than 6 dBi provided the maximum conducted output power of the intentional radiator is reduced by 1 dB for every 3 dB that the directional gain of the antenna exceeds 6 dBi.

(ii) Systems operating in the 5725–5850 MHz band that are used exclusively for fixed, point-to-point operations may employ transmitting antennas with directional gain greater than 6 dBi without any corresponding reduction in transmitter conducted output power.

§15.31 (e) For intentional radiators, measurements of the variation of the input power or the radiated signal level of the fundamental frequency component of the emission, as appropriate, shall be performed with the supply voltage varied between 85% and 115% of the nominal rated supply voltage. For battery operated equipment, the equipment tests shall be performed using a new battery.



Specification for Peak Output Power Limits (continued)

Industry Canada RSS-210 §A8.4 (4)

(4) For systems employing digital modulation techniques operating in the bands 902-928 MHz, 2400-2483.5 MHz and 5725-5850 MHz, the maximum peak conducted output power shall not exceed 1 W. Except as provided in Section A8.4 (5), the e.i.r.p. shall not exceed 4 W.

As an alternative to a peak power measurement, compliance can be based on a measurement of the maximum conducted output power. The maximum conducted output power is the total transmit power delivered to all antennas and antenna elements, averaged across all symbols in the signalling alphabet when the transmitter is operating at its maximum power control level. Power must be summed across all antennas and antenna elements. The average must not include any time intervals during which the transmitter is off or transmitting at a reduced power level. If multiple modes of operation are implemented, the maximum conducted output power is the highest total transmit power occurring in any mode.

(5) Point-to-point systems in the bands 2400-2483.5 MHz and 5725-5850 MHz are permitted to have an e.i.r.p. higher than 4 W provided that the higher e.i.r.p. is achieved by employing higher gain directional antennas and not higher transmitter output powers. Point-to-multipoint systems, omnidirectional applications and multiple co-located transmitters transmitting the same information are prohibited from exceeding 4 W e.i.r.p. However, remote stations of point-to-multipoint systems shall be allowed to operate at greater than 4 W e.i.r.p. under the same conditions as for point-to-point systems.

Note: "Fixed point-to-point operation" excludes point-to-multipoint systems, omnidirectional applications and multiple co-located transmitters transmitting the same information.

Traceability

Method	Test Equipment Used
Measurements were made per work instruction WI-01 'Measuring RF Output Power'	0158, 0252, 0313, 0314, 0223, 0116, 0117, 0287, 0363



7.2.1 Measurement results for 802.11b

Test Conditions:	15.247 (b)	Rel. Humidity (%):	35 to 42
Variant:	802.11b	Ambient Temp. (°C):	19 to 22
TPC:	HIGH	Pressure (mBars):	998 to 1003
Modulation:	ON	Duty Cycle (%):	100
Beam Forming Gain (Y):	N/A dB	Antenna Gain:	1.8 dBi
Applied Voltage:	3.30 Vdc		
Notes 1:			
Notes 2:			

Test Frequency	Measured Peak Power				Total Power (dBm)		Limit	Margin
	RF Port (dBm)				Combined	Calculated		
MHz	a	b	c	d			dBm	dB
2412	14.43	--	--	--	N/A	14.43	30.00	-15.57
2437	15.05	--	--	--	N/A	15.05	30.00	-14.95
2462	11.71	--	--	--	N/A	11.71	30.00	-18.29

Measurement uncertainty:	±1.33 dB
---------------------------------	----------

Channel 11 power reduction was due to power spectral density issue



Title: Rabbit MiniCore RCM66XXW
To: FCC 47 CFR Part 15.247 & RSS-210
Serial #: DIGI25-U1 Rev A
Issue Date: 29th February 2012
Page: Page 33 of 91

7.2.2 Measurement results for 802.11g

Test Conditions:	15.247 (b)	Rel. Humidity (%):	35 to 42
Variant:	802.11g	Ambient Temp. (°C):	19 to 22
TPC:	HIGH	Pressure (mBars):	998 to 1003
Modulation:	ON	Duty Cycle (%):	100
Beam Forming Gain (Y):	N/A dB	Antenna Gain:	1.8 dBi
Applied Voltage:	3.30 Vdc		
Notes 1:			
Notes 2:			

Test Frequency	Measured Peak Power				Total Power (dBm)		Limit	Margin
	RF Port (dBm)				Combined	Calculated		
MHz	a	b	c	d			dBm	dB
2412	15.06	--	--	--	N/A	15.06	30.00	-14.94
2437	15.16	--	--	--	N/A	15.16	30.00	-14.84
2462	9.95	--	--	--	N/A	9.95	30.00	-20.05

Measurement uncertainty:	±1.33 dB
---------------------------------	----------

Channel 11 power reduction was due to radiated band-edge issue

This test report may be reproduced in full only. The document may only be updated by MiCOM Labs personnel. Any changes will be noted in the Document History section of the report.



7.3 Maximum Permissible Exposure

Calculations for Maximum Permissible Exposure Levels

$$\text{Power Density} = P_d \text{ (mW/cm}^2\text{)} = \text{EIRP}/(4\pi d^2)$$

$$\text{EIRP} = P * G$$

P = Peak output power (mW)

G = Antenna numeric gain (numeric)

d = Separation distance (cm)

$$\text{Numeric Gain} = 10^{(G \text{ (dBi)}/10)}$$

The Peak Power in mW is the highest transmitter power measured and summed across all transmitters. Because the EUT belongs to the General Population/Uncontrolled Exposure the limit of power density is 1.0 mW/cm²

Freq. Band (MHz)	Antenna Gain		Peak Output Power		Power Density (S) @ 20cm mW/cm ²
	(dBi)	(numeric)	(dBm)	(mW)	
2.4 - 4.835	1.8	1.5	+15.16	32.81	0.01

Note: for mobile or fixed location transmitters the minimum separation distance is 20cm, even if calculations indicate the MPE distance to be less.

Specification

Maximum Permissible Exposure Limits

FCC §1.1310

Limit = 1mW / cm² from 1.310 Table 1

RSS-Gen §5.6

Exposure of Humans to RF Fields: Category I and Category II equipment shall comply with the applicable requirements of RSS-102.

Laboratory Measurement Uncertainty for Power Measurements

Measurement uncertainty	±1.33 dB
-------------------------	----------

This test report may be reproduced in full only. The document may only be updated by MiCOM Labs personnel. Any changes will be noted in the Document History section of the report.

7.4 Peak Power Spectral Density

Test Procedure

The test methodology and conditions utilized for each measurement is referenced in the following test results matrix. RF output power, transmit power control and power density were measured per the Test Configuration identified below.

Testing was performed on the highest and lowest power settings of the equipment.

Per the standard measurements were taken at ambient and extreme temperature conditions at nominal and extreme voltage levels.

Test Configuration

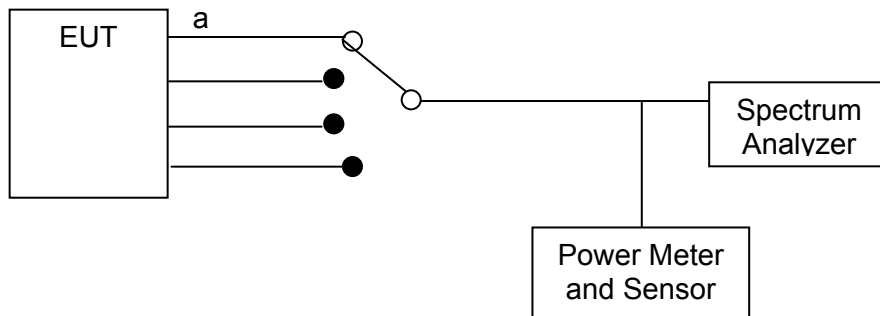

Measurement setup for Peak Power Spectral Density



Specification for Peak Power Spectral Density Limits

FCC §15.247 (e)

For digitally modulated systems, the power spectral density conducted from the intentional radiator to the antenna shall not be greater than +8 dBm in any 3 kHz band during any time interval of continuous transmission

Industry Canada RSS-210 §A8.2 (b)

These include systems that employ digital modulation techniques resulting in spectral characteristics similar to direct sequence systems. The following applies to all three bands:

(a) The minimum -6 dB bandwidth shall be at least 500 kHz.

(b) The transmitter power spectral density conducted from the transmitter to the antenna shall not be greater than 8 dBm in any 3 kHz band during any time interval of continuous transmission. This power spectral density shall be determined in accordance with the provisions of Section A8.4 (4), (i.e. the power spectral density shall be determined using the same method as is used to determine the conducted output power).

Traceability

Method	Test Equipment Used
Measurements were made per work instruction WI-01 'Measuring RF Output Power'	0158, 0252, 0313, 0314, 0223, 0116, 0117, 0287, 0363



7.4.1 Measurement results for 802.11b

Test Conditions:	15.247 (e)	Rel. Humidity (%):	35	to	42
Variant:	802.11b	Ambient Temp. (°C):	19	to	22
TPC:	HIGH	Pressure (mBars):	998	to	1003
Modulation:	ON	Duty Cycle (%):	100		
Beam Forming Gain (Y):	N/A dB	Antenna Gain:	1.8 dBi		
Applied Voltage:	3.30 Vdc	Antenna Ports (N):	1		
Notes 1:					
Notes 2:					

Test Frequency	Measured Power Density				Correction factor	Peak Power Spectral Density	Limit	Margin
	RF Port (dBm)							
MHz	a	b	c	d	10Log(N)	dBm	dBm	dB
2412	-3.48	--	--	--	0.00	-3.48	8.00	-11.48
2437	7.84	--	--	--	0.00	7.84	8.00	-0.16
2462	7.72	--	--	--	0.00	7.72	8.00	-0.28

Measurement uncertainty:	± 1.33 dB
---------------------------------	-----------

Power reduction required on Channels 6 (2437 MHz) & 11 (2462 MHz), see plots



Title: Rabbit MiniCore RCM66XXW
To: FCC 47 CFR Part 15.247 & RSS-210
Serial #: DIGI25-U1 Rev A
Issue Date: 29th February 2012
Page: Page 38 of 91

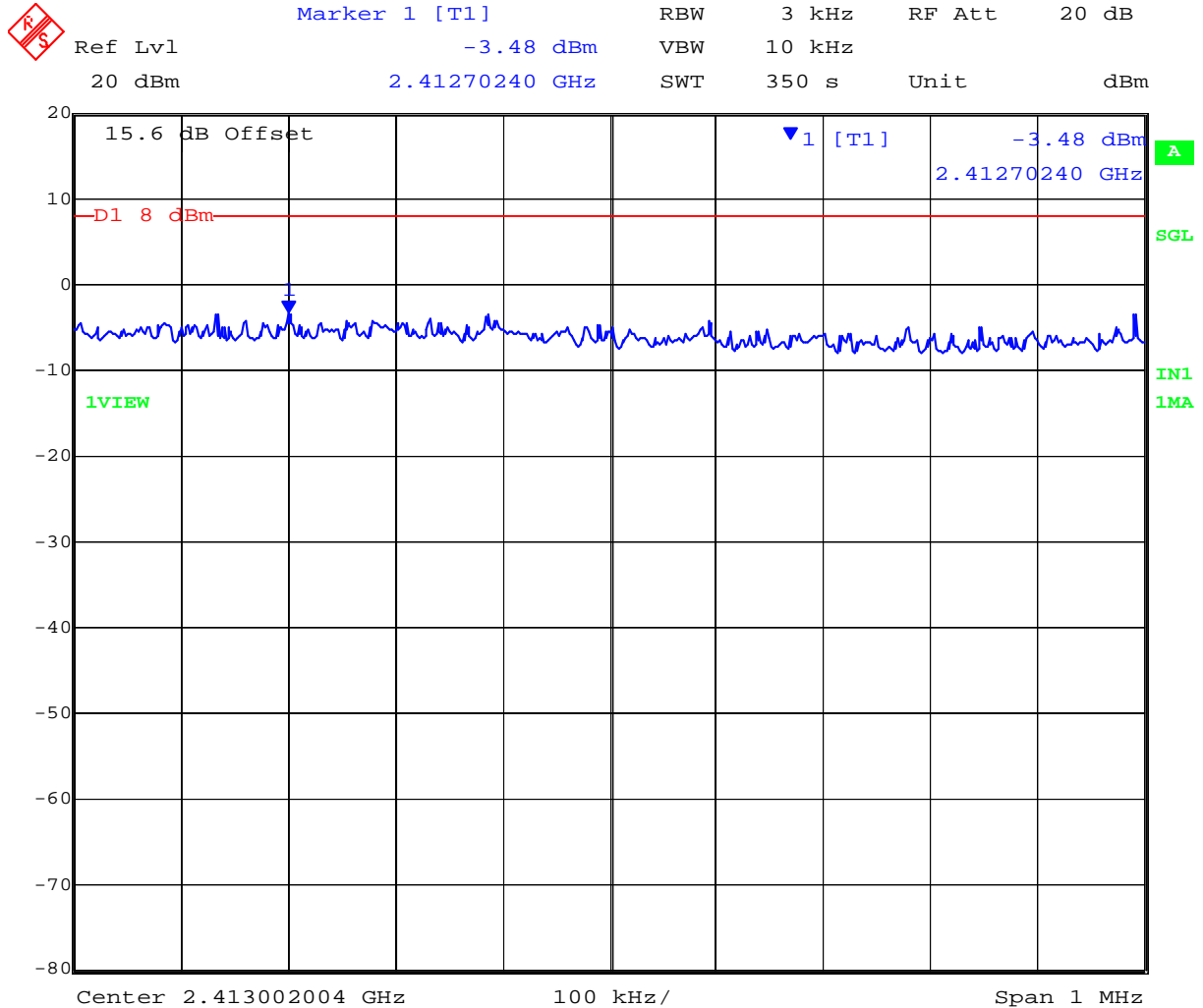

Date: 31.JAN.2012 14:50:35

This test report may be reproduced in full only. The document may only be updated by MiCOM Labs personnel. Any changes will be noted in the Document History section of the report.



Title: Rabbit MiniCore RCM66XXW
To: FCC 47 CFR Part 15.247 & RSS-210
Serial #: DIGI25-U1 Rev A
Issue Date: 29th February 2012
Page: Page 39 of 91

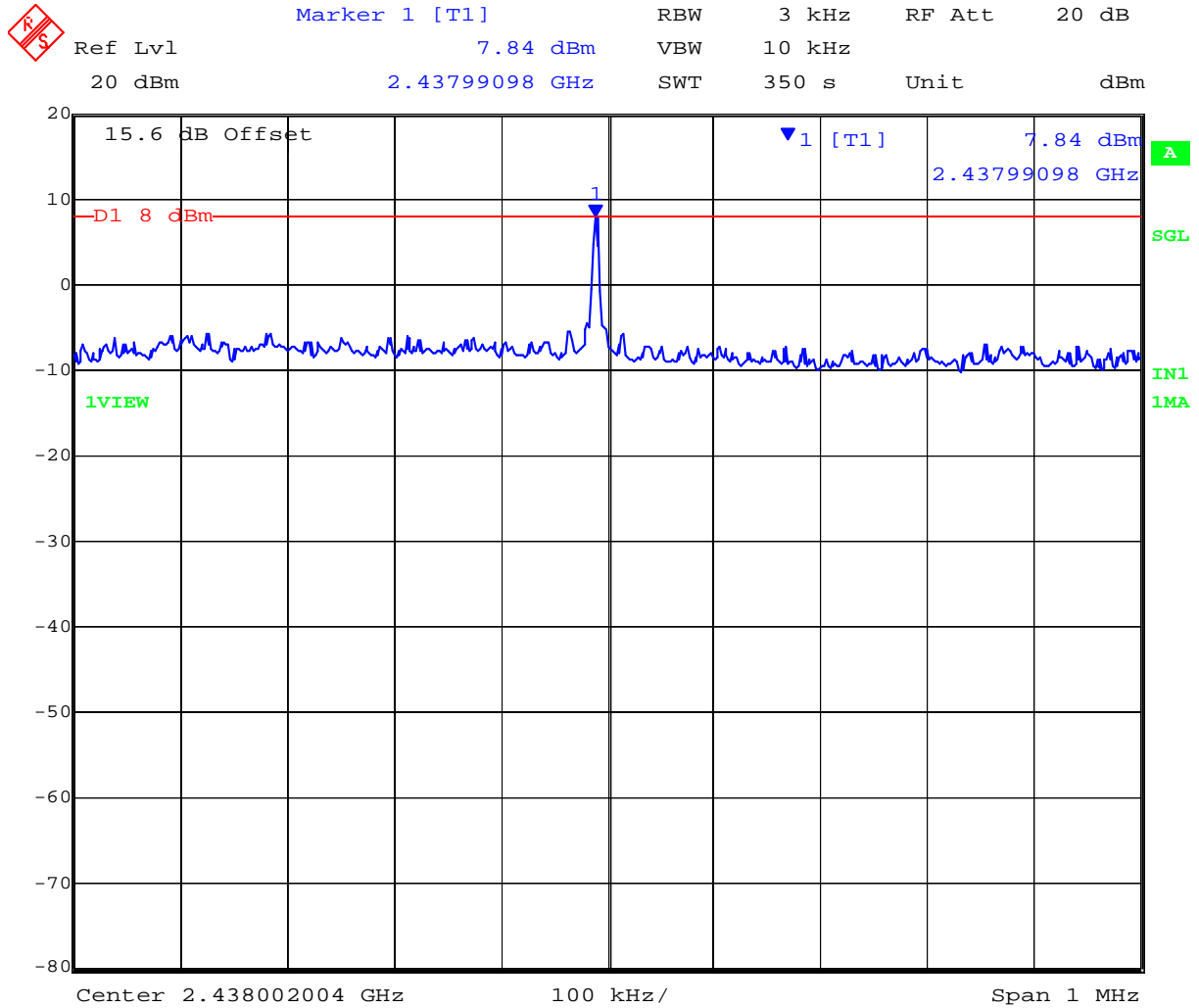

Date: 31.JAN.2012 15:24:53

Power reduction required

This test report may be reproduced in full only. The document may only be updated by MiCOM Labs personnel. Any changes will be noted in the Document History section of the report.



Title: Rabbit MiniCore RCM66XXW
To: FCC 47 CFR Part 15.247 & RSS-210
Serial #: DIGI25-U1 Rev A
Issue Date: 29th February 2012
Page: Page 40 of 91

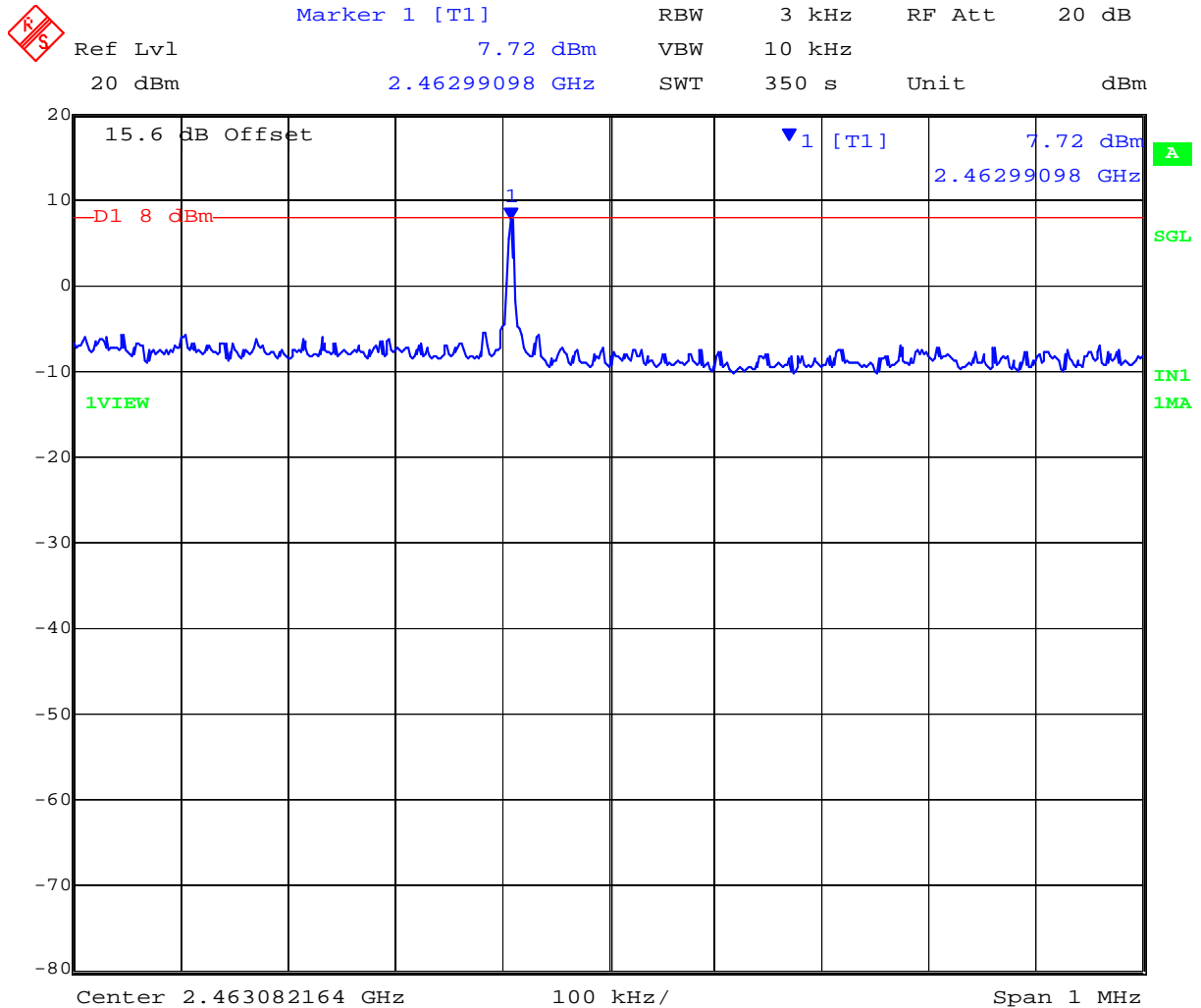

Date: 31.JAN.2012 15:49:40

Power reduction required

This test report may be reproduced in full only. The document may only be updated by MiCOM Labs personnel. Any changes will be noted in the Document History section of the report.



Title: Rabbit MiniCore RCM66XXW
To: FCC 47 CFR Part 15.247 & RSS-210
Serial #: DIGI25-U1 Rev A
Issue Date: 29th February 2012
Page: Page 41 of 91

7.4.2 Measurement results for 802.11g

Test Conditions:	15.247 (e)	Rel. Humidity (%):	35	to	42
Variant:	802.11g	Ambient Temp. (°C):	19	to	22
TPC:	HIGH	Pressure (mBars):	998	to	1003
Modulation:	ON	Duty Cycle (%):	100		
Beam Forming Gain (Y):	N/A dB	Antenna Gain:	1.8 dBi		
Applied Voltage:	3.30 Vdc	Antenna Ports (N):	1		
Notes 1:					
Notes 2:					

Test Frequency	Measured Power Density				Correction factor	Peak Power Spectral Density	Limit	Margin
	RF Port (dBm)							
MHz	a	b	c	d	10Log(N)	dBm	dBm	dB
2412.000	-8.69	--	--	--	0.00	-8.69	8.00	-16.69
2437.000	-9.55	--	--	--	0.00	-9.55	8.00	-17.55
2462.000	-9.01	--	--	--	0.00	-9.01	8.00	-17.01

Measurement uncertainty:	± 1.33 dB
---------------------------------	-----------

This test report may be reproduced in full only. The document may only be updated by MiCOM Labs personnel. Any changes will be noted in the Document History section of the report.



Title: Rabbit MiniCore RCM66XXW
To: FCC 47 CFR Part 15.247 & RSS-210
Serial #: DIGI25-U1 Rev A
Issue Date: 29th February 2012
Page: Page 42 of 91

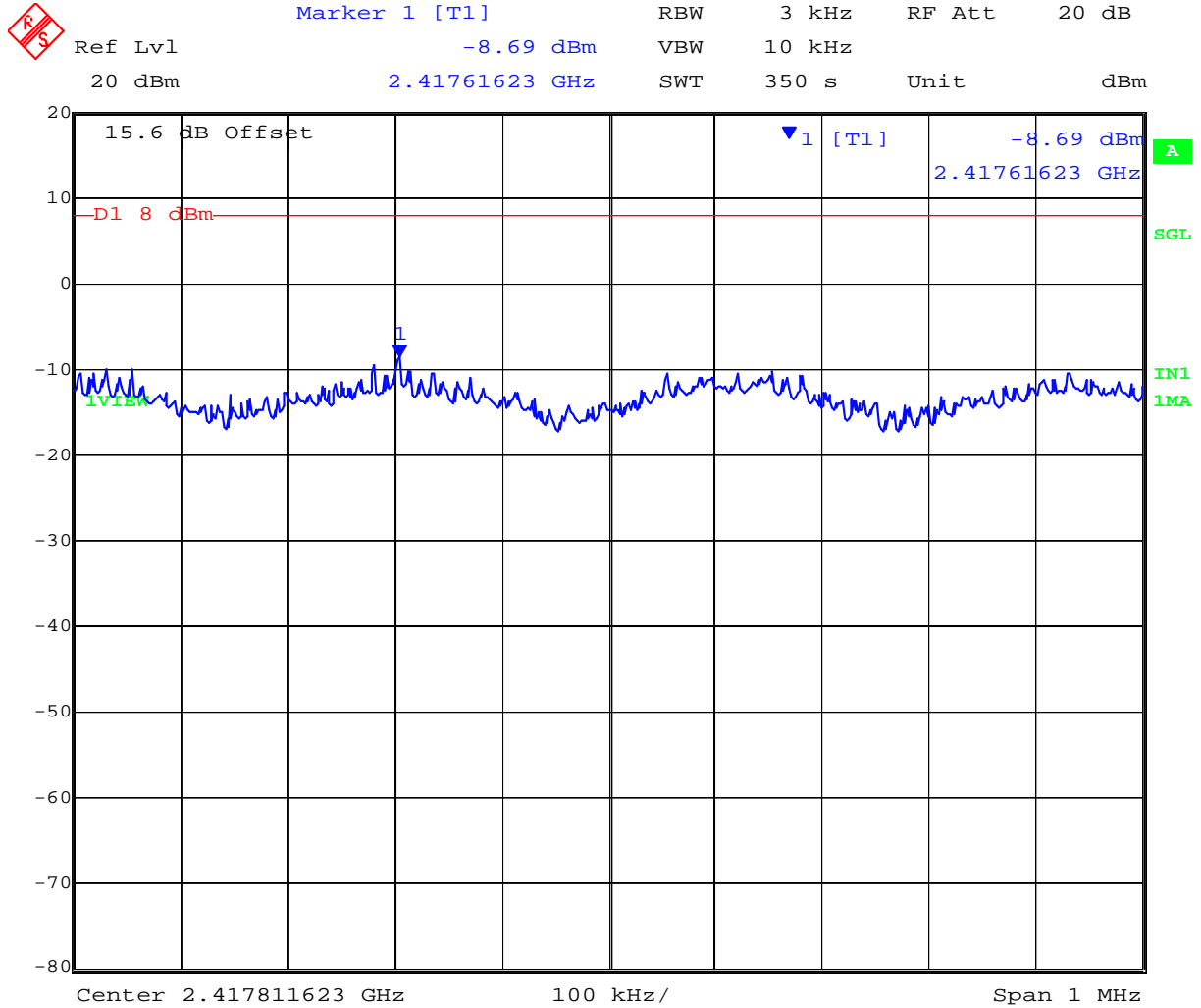

Date: 31.JAN.2012 16:21:12

This test report may be reproduced in full only. The document may only be updated by MiCOM Labs personnel. Any changes will be noted in the Document History section of the report.



Title: Rabbit MiniCore RCM66XXW
To: FCC 47 CFR Part 15.247 & RSS-210
Serial #: DIGI25-U1 Rev A
Issue Date: 29th February 2012
Page: Page 43 of 91



Date: 31.JAN.2012 16:37:02

This test report may be reproduced in full only. The document may only be updated by MiCOM Labs personnel. Any changes will be noted in the Document History section of the report.



Title: Rabbit MiniCore RCM66XXW
To: FCC 47 CFR Part 15.247 & RSS-210
Serial #: DIGI25-U1 Rev A
Issue Date: 29th February 2012
Page: Page 44 of 91

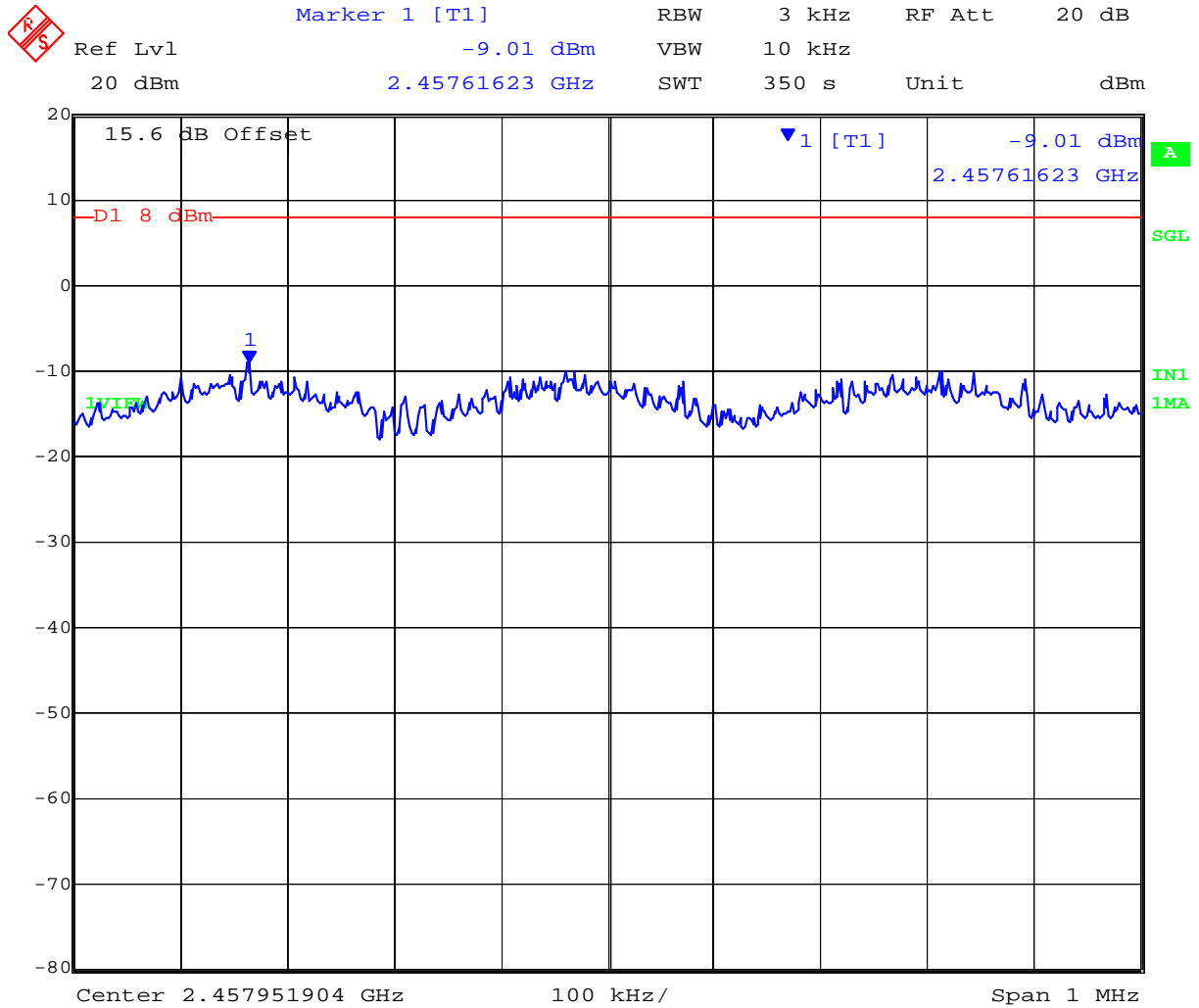

Date: 31.JAN.2012 16:51:20

This test report may be reproduced in full only. The document may only be updated by MiCOM Labs personnel. Any changes will be noted in the Document History section of the report.

7.5 Conducted Spurious Emissions

Test Procedure

Conducted emissions were measured at a limit of 20 dB below the highest in-band spectral density measured with a spectrum analyzer connected to the antenna terminal. Emissions at the band edge were measured and recorded. Measurements were made while EUT was operating in transmit mode of operation at the appropriate center frequency.

Measurements were made using a combiner with the transmitter tuned to the channel closest to the band-edge being measured. All emissions were maximized during measurement. Limits which were derived from the peak emission.

Test Configuration

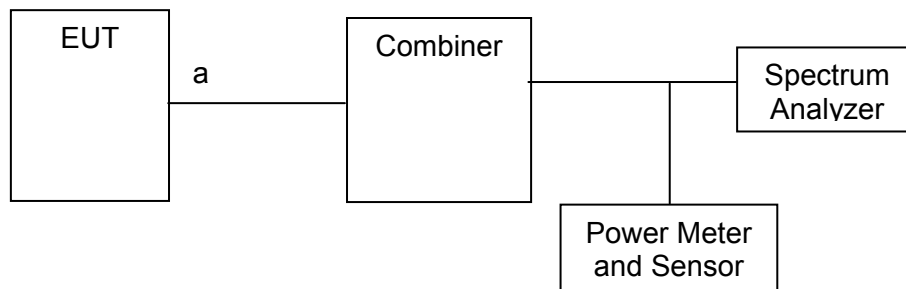

Measurement setup for Conducted Spurious Emission



Specification for Band Edge Limits

FCC §15.247(d)

In any 100 kHz bandwidth outside the frequency band in which the spread spectrum or digitally modulated intentional radiator is operating, the radio frequency power that is produced by the intentional radiator shall be at least 20 dB below that in the 100 kHz bandwidth within the band that contains the highest level of the desired power, based on either an RF conducted or radiated measurement, provided the transmitter demonstrates compliance with the peak conducted power limits.

FCC §15.247(d)

If the transmitter complies with the conducted power limits based on the use of RMS averaging over a time interval, as permitted under paragraph (b)(3) of this section, the attenuation required under this paragraph shall be 30 dB instead of 20 dB. Attenuation below the general limits specified §15.209(a) is not required. In addition, radiated emissions which fall in the restricted bands, as defined in Section §15.205(a), must also comply with the radiated emission limits specified in Section 15.209(a) (see Section 15.205(a)).

Limits Band-Edge

Lower Limit Band-edge	Upper Limit Band-edge	Limit below highest level of desired power
2,400 MHz	2,483.5 MHz	≥ 20 dB
5725 MHz	5850 MHz	



Title: Rabbit MiniCore RCM66XXW
To: FCC 47 CFR Part 15.247 & RSS-210
Serial #: DIGI25-U1 Rev A
Issue Date: 29th February 2012
Page: Page 47 of 91

Industry Canada RSS-210 §A8.5

Out-of-band Emissions: In any 100 kHz bandwidth outside the frequency band in which the spread spectrum or digitally modulated device is operating, the RF power that is produced shall be at least 20 dB below that in the 100 kHz bandwidth within the band that contains the highest level of the desired power, based on either an RF conducted or a radiated measurement, provided that the transmitter demonstrates compliance with the peak conducted power limits. If the transmitter complies with the conducted power limits based on the use of root-mean-square averaging over a time interval, as permitted under Section A8.4 (4), the attenuation required shall be 30 dB instead of 20 dB. Attenuation below the general field strength limits specified in RSS-Gen is not required.

RSS-GEN 6.2

If the receiver has a detachable antenna of known impedance, antenna conducted spurious emissions measurement is permitted as an alternative to radiated measurement. However, the radiated method of Section 6.1 is recommended:

The antenna conducted test shall be performed with the antenna disconnected and the receiver antenna terminals connected to a measuring instrument having equal impedance to that specified for the antenna

The receiver spurious emissions measured at the antenna terminals by the antenna conducted method shall then comply with the following limits:

Receiver spurious emissions at any discrete frequency shall not exceed 2 nanowatts in the band 30-1000 MHz, and 5 nanowatts above 1000 MHz.

Traceability

Method	Test Equipment Used
WI-05	0158, 0252, 0313, 0314, 0223, 0116, 0117, 0287, 0363.

This test report may be reproduced in full only. The document may only be updated by MiCOM Labs personnel. Any changes will be noted in the Document History section of the report.



7.5.1 Measurement Results for 802.11b

Test Conditions:	15.247 (a)(2)	Rel. Humidity (%):	35	to	42
Variant:	802.11b	Ambient Temp. (°C):	19	to	22
TPC:	HIGH	Pressure (mBars):	998	to	1003
Modulation:	ON	Duty Cycle (%):	100		
Beam Forming Gain	N/A dB	Antenna Gain:	N/A dBi		
Applied Voltage:	3.30 Vdc	Antenna Ports (N):			
Notes 1:					
Notes 2:					

Conducted Spurious Measurement

Test Freq.	Start Freq.	Stop Freq.	Port A		Port B		Port C		Port D	
			SE dBm	Limit dBm	SE dBm	Limit dBm	SE dBm	Limit dBm	SE dBm	Limit dBm
2412.000	30.00	26000.00	-34.88	-11.12						
2437.000	30.00	26000.00	-38.55	-13.10						
2462.000	30.00	26000.00	-40.67	-12.34						

SE: Maximum spurious emission found

Band-edge Measurement

Test Freq.	Band-edge freq.	Port A		Port B		Port C		Port D	
		BE dBm	Limit dBm	BE dBm	Limit dBm	BE dBm	Limit dBm	BE dBm	Limit dBm
2412.000	2400.00	-38.63	-10.45						
2462.000	2483.50	-48.90	-11.23						

BE: Maximum Band edge emission found

Measurement uncertainty:	±2.81 dB
---------------------------------	----------

Note: Limit is based on 20dB down from fundamental emissions



Title: Rabbit MiniCore RCM66XXW
To: FCC 47 CFR Part 15.247 & RSS-210
Serial #: DIGI25-U1 Rev A
Issue Date: 29th February 2012
Page: Page 49 of 91

Test Conditions:	15.247 (a)(2)	Rel. Humidity (%):	35	to	42
Variant:	802.11b	Ambient Temp. (°C):	19	to	22
TPC:	HIGH	Pressure (mBars):	998	to	1003
Modulation:	ON	Duty Cycle (%):	100		
Beam Forming Gain	N/A dB	Antenna Gain:	N/A dBi		
Applied Voltage:	3.30 Vdc	Antenna Ports (N):			
Notes 1:					
Notes 2:					

Conducted Spurious Measurement

Test Freq.	Start Freq.	Stop Freq.	Port A		Port B		Port C		Port D	
			SE dBm	Limit dBm	SE dBm	Limit dBm	SE dBm	Limit dBm	SE dBm	Limit dBm
2412.000	30.00	26000.00	-34.88	-11.12						
2437.000	30.00	26000.00	-38.55	-13.10						
2462.000	30.00	26000.00	-40.67	-12.34						

SE: Maximum spurious emission found

Band-edge Measurement

Test Freq.	Band-edge freq.	Port A		Port B		Port C		Port D	
		BE dBm	Limit dBm	BE dBm	Limit dBm	BE dBm	Limit dBm	BE dBm	Limit dBm
2412.000	2400.00	-38.63	-10.45						
2462.000	2483.50	-48.90	-11.23						

BE: Maximum Band edge emission found

Measurement uncertainty:	±2.81 dB
---------------------------------	----------

Note: Limit is based on 20dB down from fundamental emissions

This test report may be reproduced in full only. The document may only be updated by MiCOM Labs personnel. Any changes will be noted in the Document History section of the report.



Title: Rabbit MiniCore RCM66XXW
To: FCC 47 CFR Part 15.247 & RSS-210
Serial #: DIGI25-U1 Rev A
Issue Date: 29th February 2012
Page: Page 50 of 91

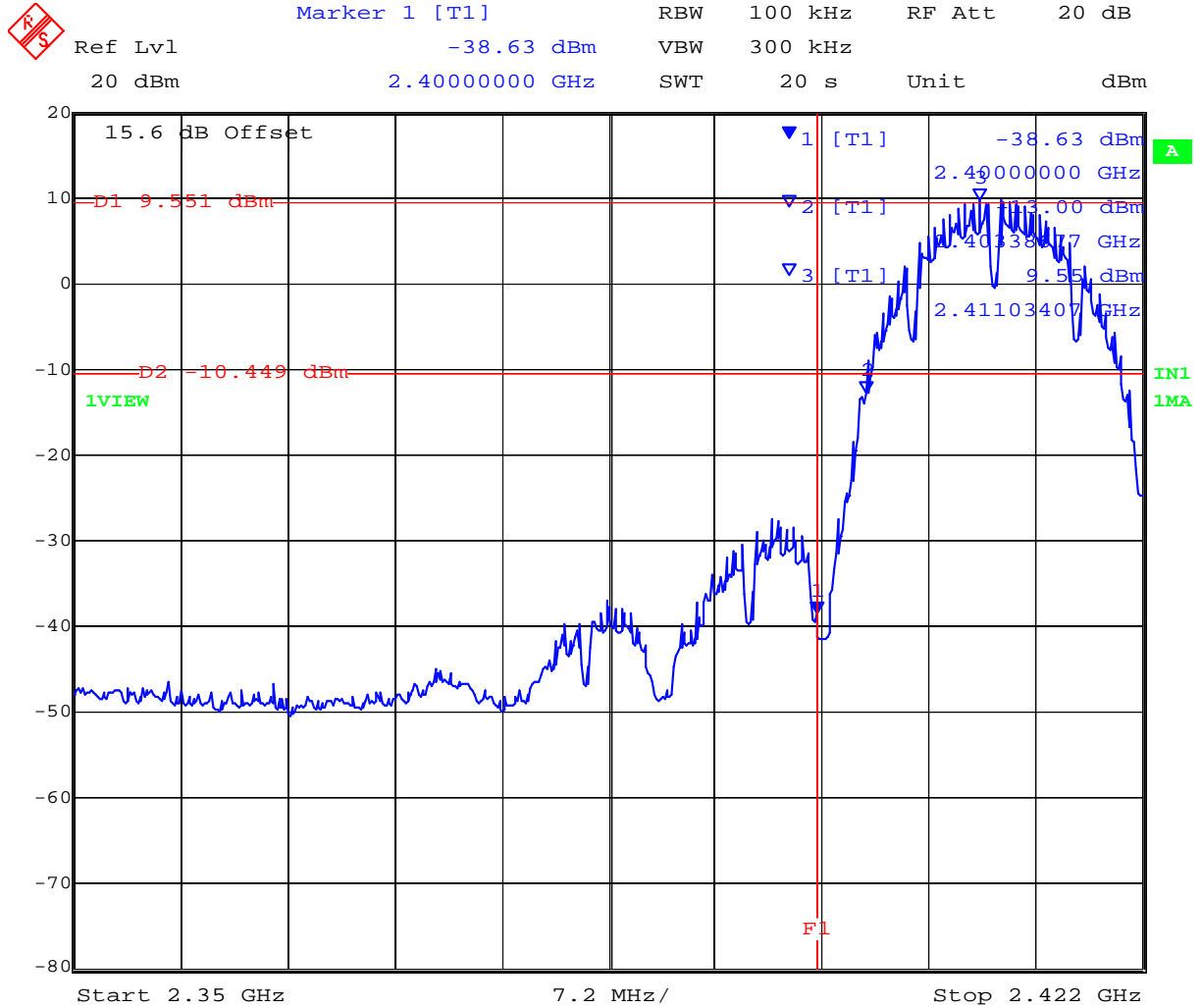

Date: 31.JAN.2012 14:44:03

This test report may be reproduced in full only. The document may only be updated by MiCOM Labs personnel. Any changes will be noted in the Document History section of the report.

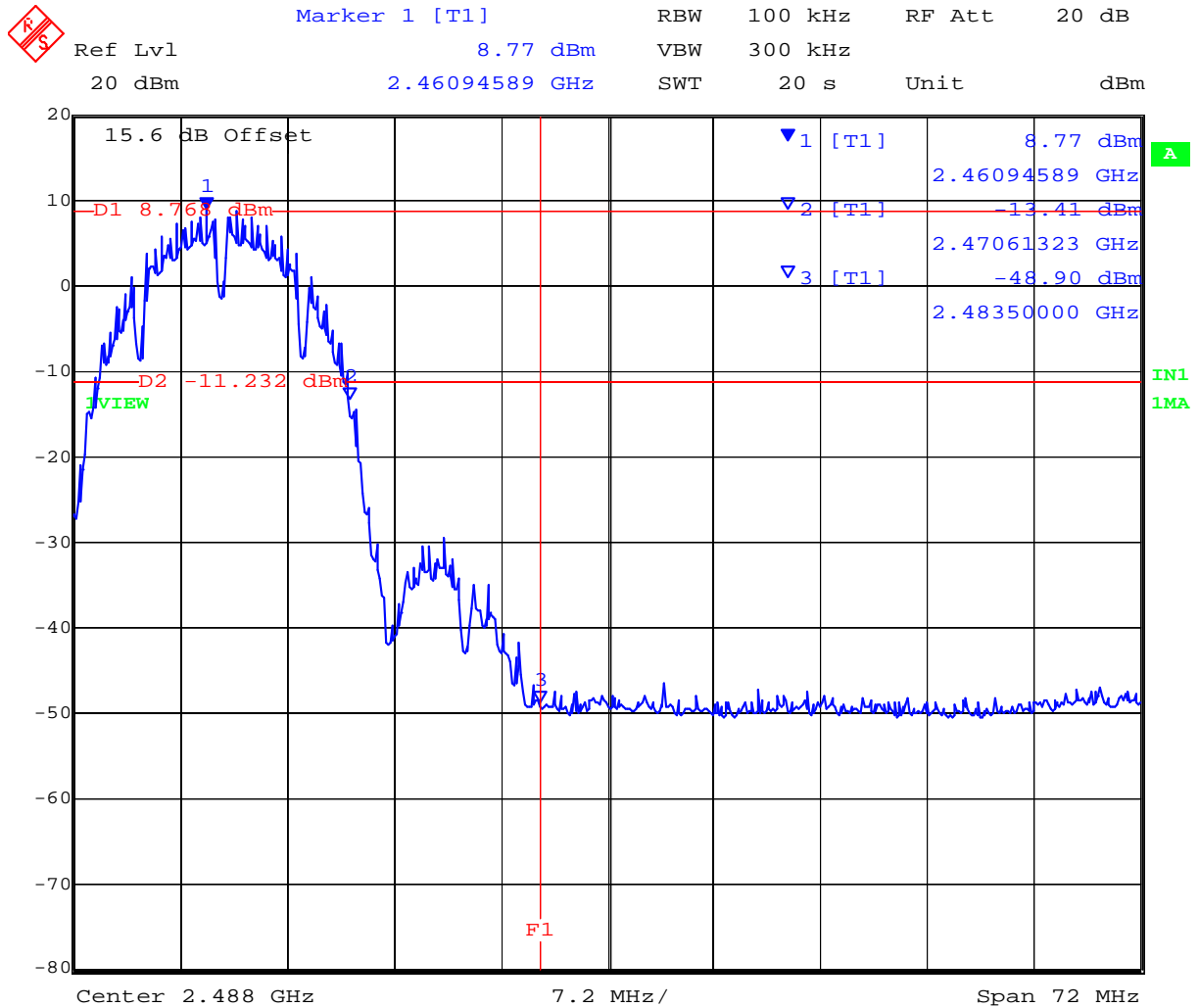

Date: 31.JAN.2012 15:31:04

This test report may be reproduced in full only. The document may only be updated by MiCOM Labs personnel. Any changes will be noted in the Document History section of the report.

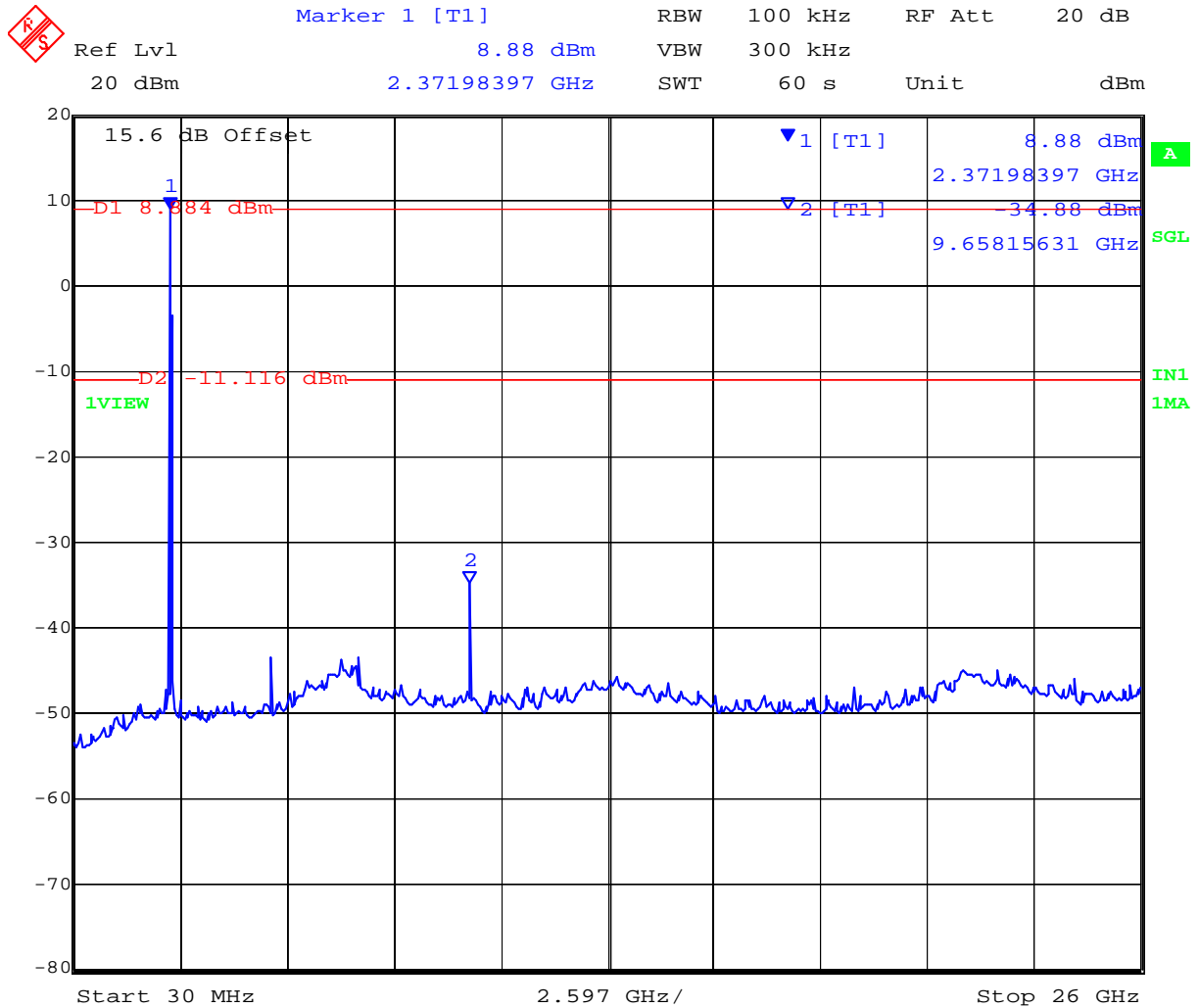

Date: 31.JAN.2012 14:52:36

This test report may be reproduced in full only. The document may only be updated by MiCOM Labs personnel. Any changes will be noted in the Document History section of the report.

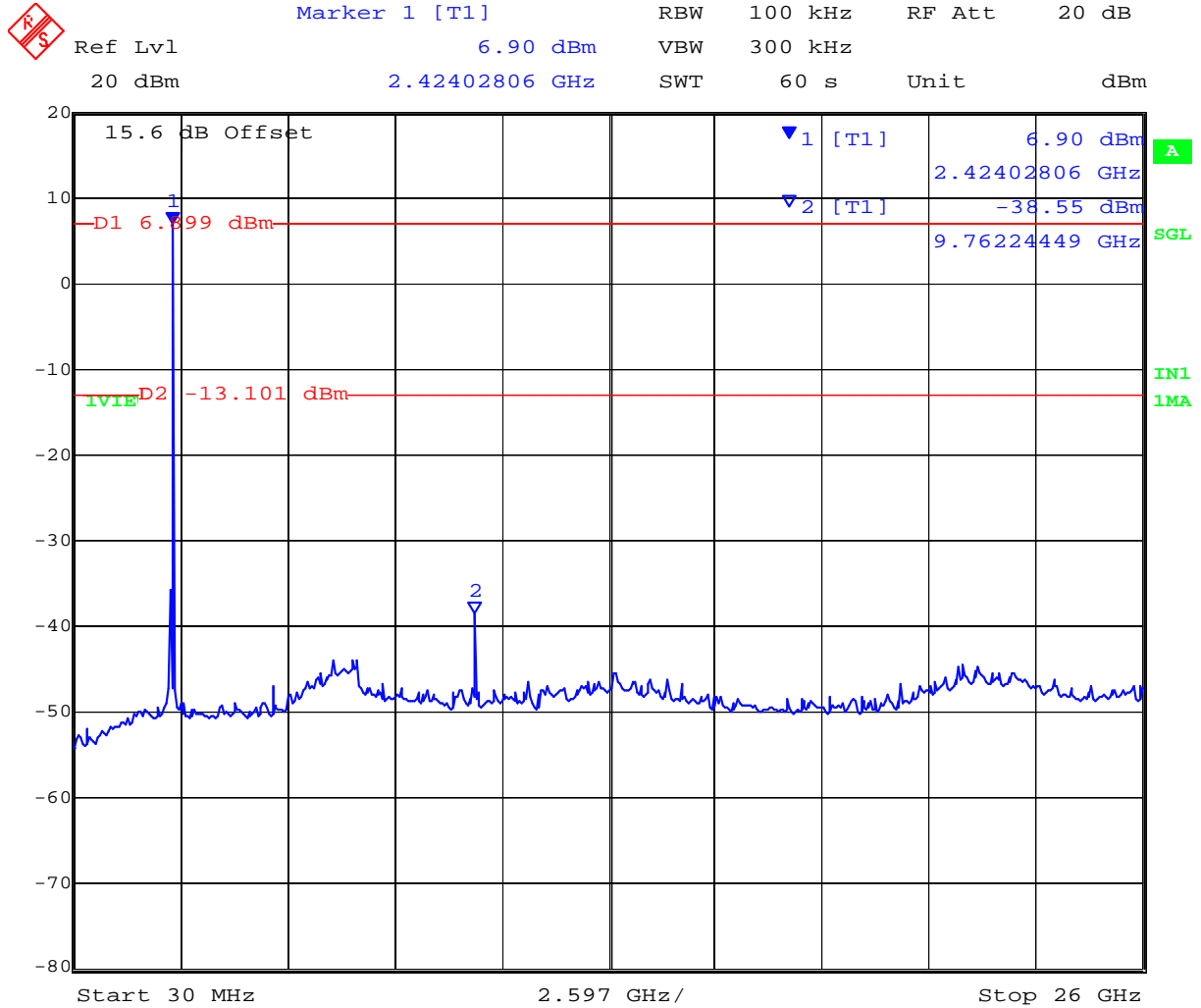

This test report may be reproduced in full only. The document may only be updated by MiCOM Labs personnel. Any changes will be noted in the Document History section of the report.

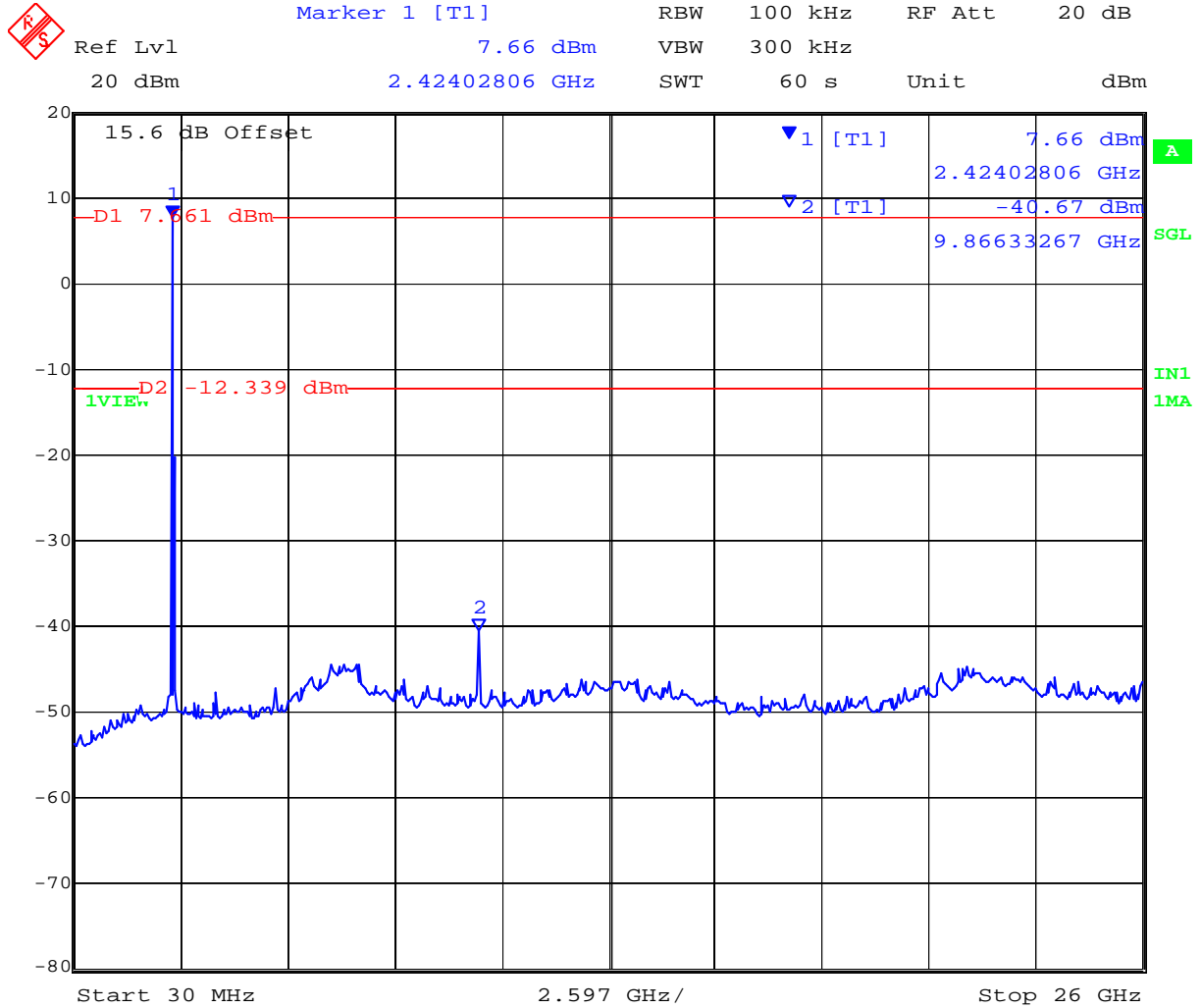

Date: 31.JAN.2012 15:39:43

This test report may be reproduced in full only. The document may only be updated by MiCOM Labs personnel. Any changes will be noted in the Document History section of the report.



7.5.2 Measurement Results for 802.11g

Test Conditions:	15.247 (a)(2)	Rel. Humidity (%):	35	to	42
Variant:	802.11g	Ambient Temp. (°C):	19	to	22
TPC:	HIGH	Pressure (mBars):	998	to	1003
Modulation:	ON	Duty Cycle (%):	100		
Beam Forming Gain	N/A dB	Antenna Gain:	N/A dBi		
Applied Voltage:	3.30 Vdc	Antenna Ports (N):			
Notes 1:					
Notes 2:					

Conducted Spurious Measurement

Test Freq.	Start Freq.	Stop Freq.	Port A		Port B		Port C		Port D	
			SE dBm	Limit dBm	SE dBm	Limit dBm	SE dBm	Limit dBm	SE dBm	Limit dBm
2412.000	30.00	26000.00	-44.31	-17.97						
2437.000	30.00	26000.00	-43.77	-18.35						
2462.000	30.00	26000.00	-44.38	-18.82						

SE: Maximum spurious emission found

Band-edge Measurement

Test Freq.	Band-edge freq.	Port A		Port B		Port C		Port D	
		BE dBm	Limit dBm	BE dBm	Limit dBm	BE dBm	Limit dBm	BE dBm	Limit dBm
2412.000	2400.00	-26.49	-17.64						
2462.000	2483.50	-35.52	-17.84						

BE: Maximum Band edge emission found

Measurement uncertainty:	±2.81 dB
---------------------------------	----------

Note: Limit is based on 20dB down from fundamental emissions

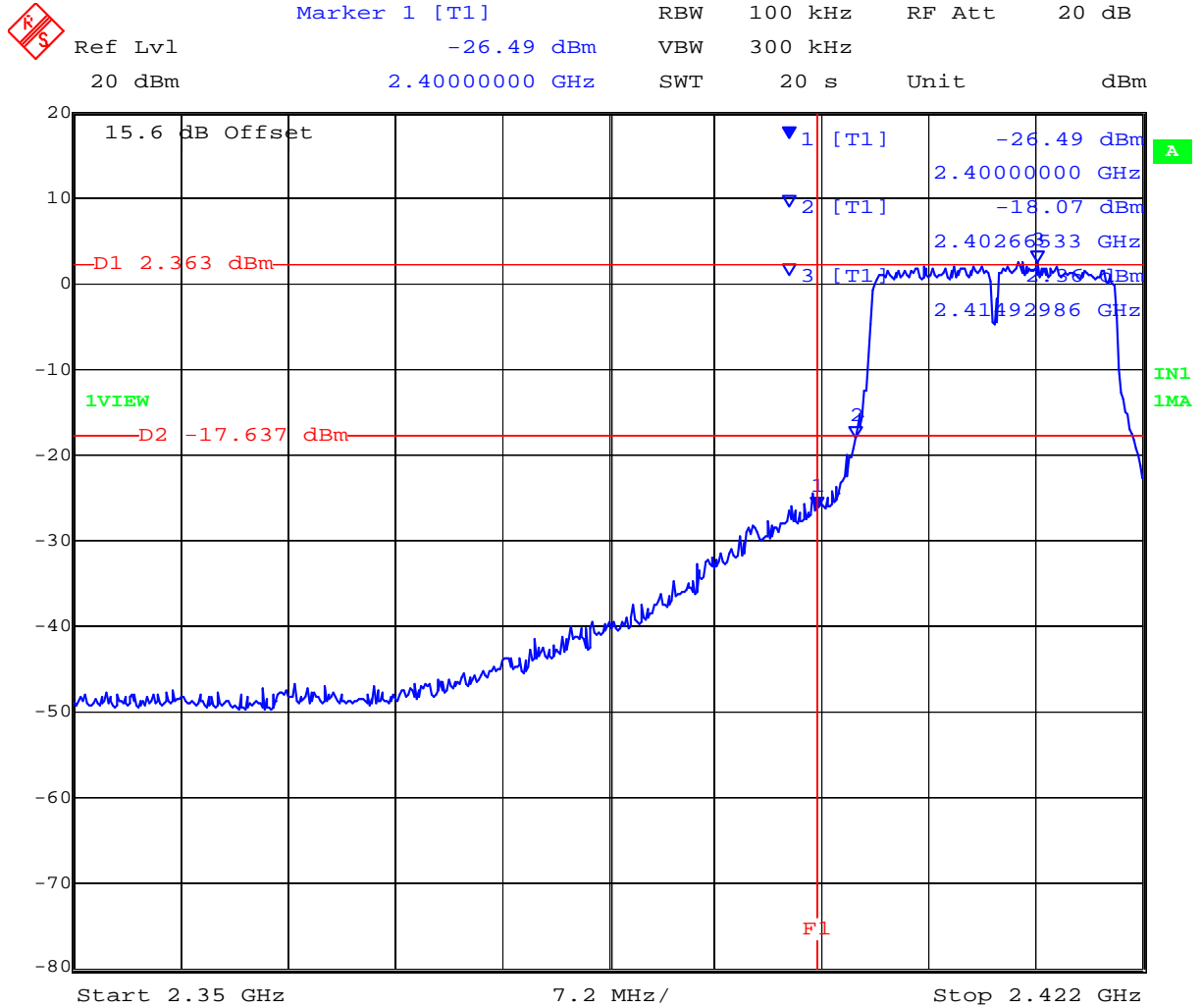

Date: 31.JAN.2012 16:14:42

This test report may be reproduced in full only. The document may only be updated by MiCOM Labs personnel. Any changes will be noted in the Document History section of the report.

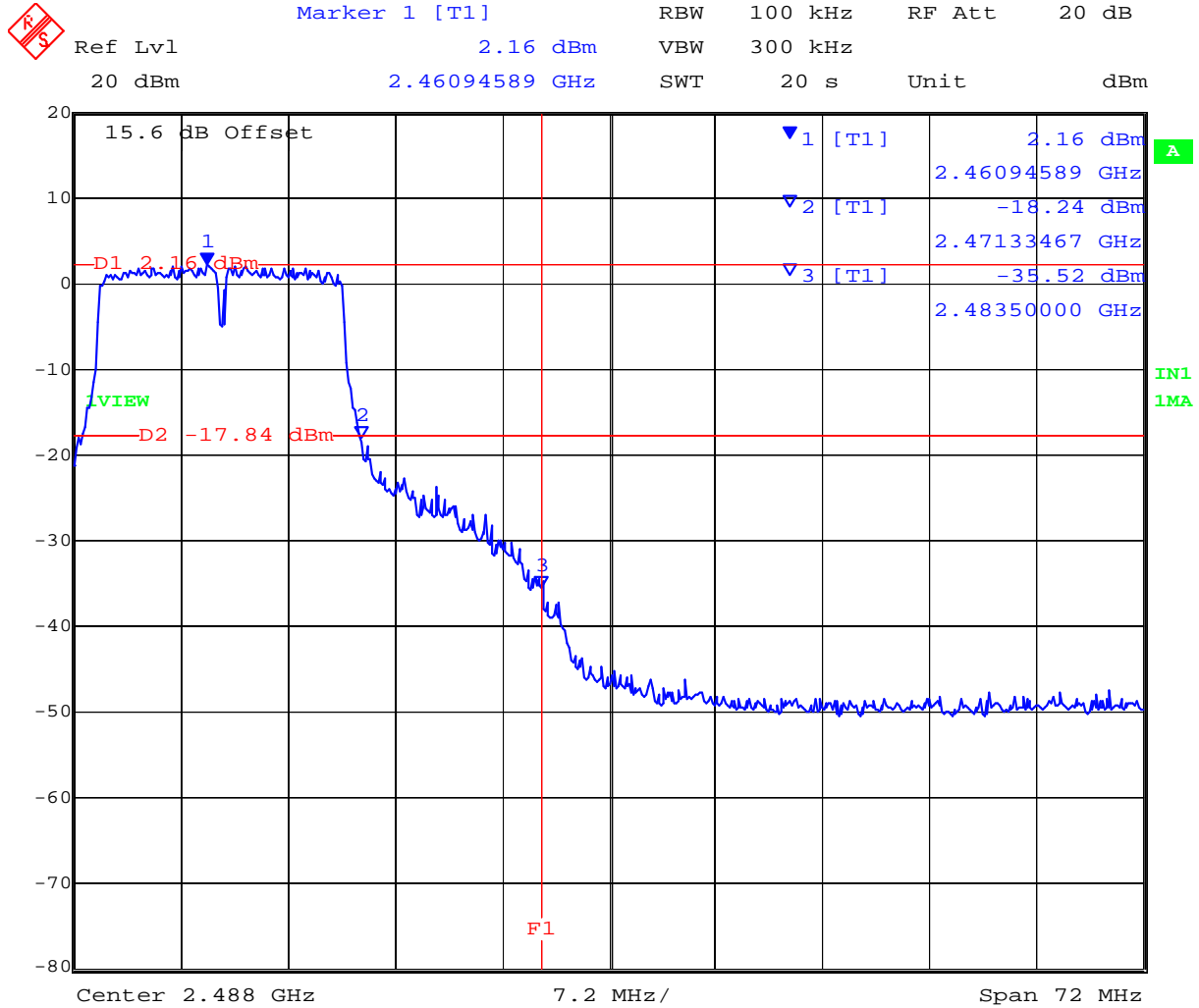

Date: 31.JAN.2012 16:44:48

This test report may be reproduced in full only. The document may only be updated by MiCOM Labs personnel. Any changes will be noted in the Document History section of the report.



Title: Rabbit MiniCore RCM66XXW
To: FCC 47 CFR Part 15.247 & RSS-210
Serial #: DIGI25-U1 Rev A
Issue Date: 29th February 2012
Page: Page 58 of 91

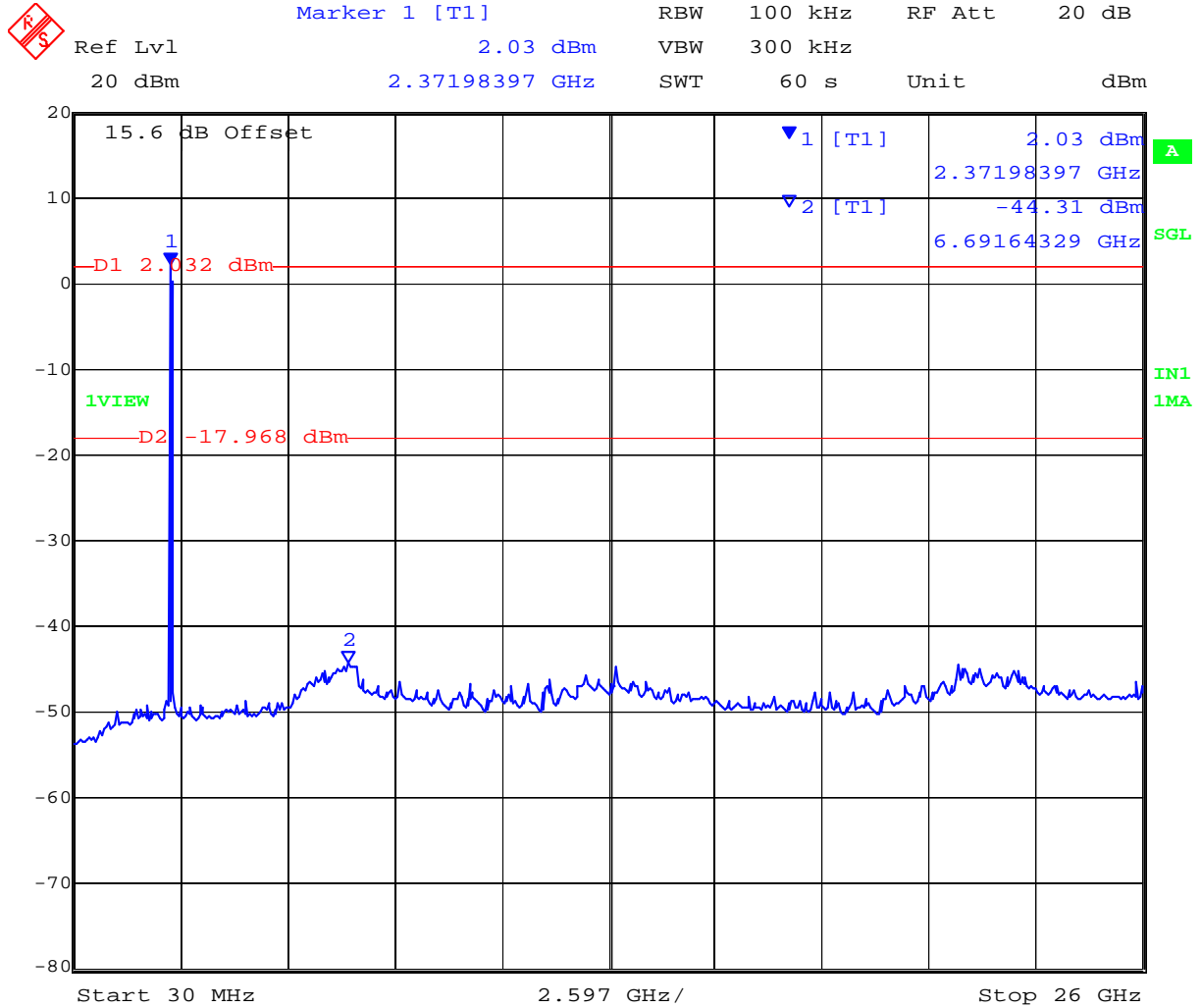

Date: 31.JAN.2012 16:23:14

This test report may be reproduced in full only. The document may only be updated by MiCOM Labs personnel. Any changes will be noted in the Document History section of the report.



Title: Rabbit MiniCore RCM66XXW
To: FCC 47 CFR Part 15.247 & RSS-210
Serial #: DIGI25-U1 Rev A
Issue Date: 29th February 2012
Page: Page 59 of 91

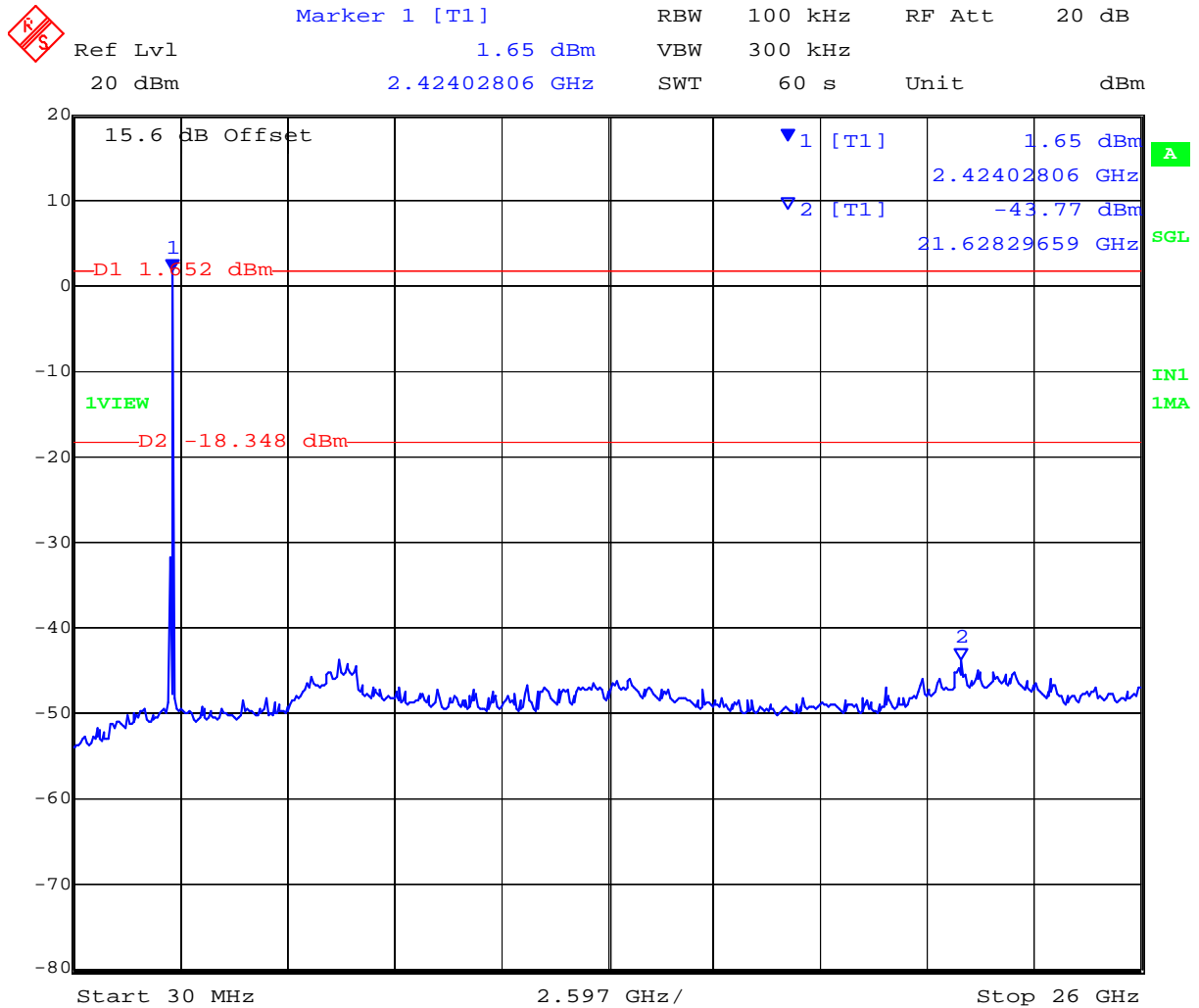

Date: 31.JAN.2012 16:39:04

This test report may be reproduced in full only. The document may only be updated by MiCOM Labs personnel. Any changes will be noted in the Document History section of the report.



Title: Rabbit MiniCore RCM66XXW
To: FCC 47 CFR Part 15.247 & RSS-210
Serial #: DIGI25-U1 Rev A
Issue Date: 29th February 2012
Page: Page 60 of 91

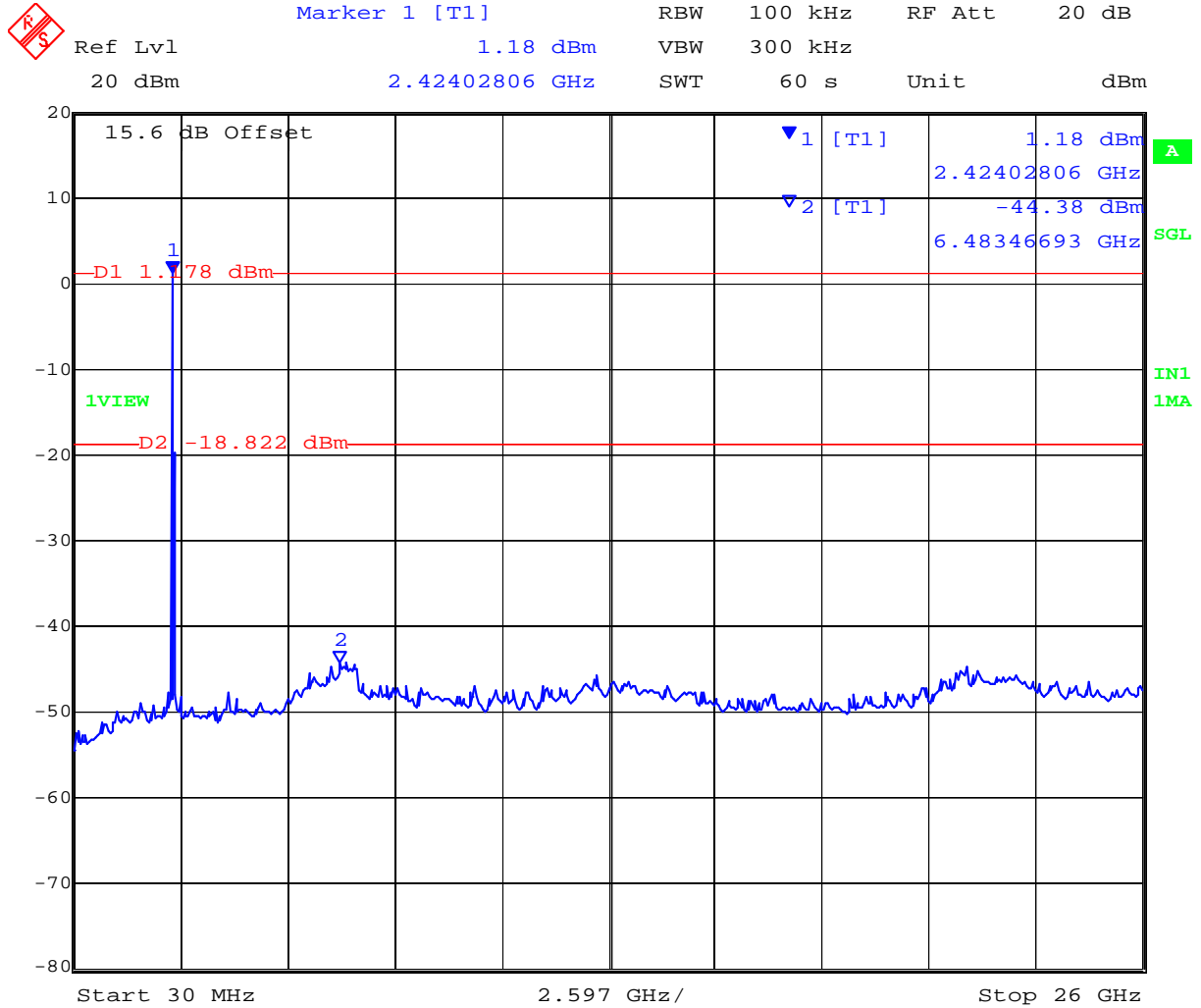

Date: 31.JAN.2012 16:53:25

This test report may be reproduced in full only. The document may only be updated by MiCOM Labs personnel. Any changes will be noted in the Document History section of the report.



Title: Rabbit MiniCore RCM66XXW
To: FCC 47 CFR Part 15.247 & RSS-210
Serial #: DIGI25-U1 Rev A
Issue Date: 29th February 2012
Page: Page 61 of 91

7.6 Radiated Spurious Emissions

Test Procedure

Testing was performed in a 3-meter anechoic chamber. Preliminary radiated emissions were measured on every azimuth and with the receiving antenna in both horizontal and vertical polarizations. Preliminary emissions were recorded with in Spectrum Analyzer mode, using a maximum peak detector while in peak hold mode.

Emissions nearest the limits were chosen for maximization and formal measurement using a CISPR Compliant receiver. Emissions above 1000 MHz are measured utilizing a CISPR compliant average detector with a tuned receiver, using a bandwidth of 1 MHz. Emissions from 30 MHz – 1000 MHz are measured utilizing a CISPR compliant quasi-peak detector with a tuned receiver, using a bandwidth of 120 kHz. Emissions above 1000 MHz are measured utilizing an average detector with a tuned receiver, using a bandwidth of 1000 MHz.

Only the highest emissions relative to the limit are listed.

To find out which was the worst case EUT position the EUT was placed horizontal and vertical on the test table top. Worst case was found to be vertical placement on the table top. The horizontal plot emissions are kept on file by the lab.

This test report may be reproduced in full only. The document may only be updated by MiCOM Labs personnel. Any changes will be noted in the Document History section of the report.

Radiated Emission Measurement Setup – Above 1 GHz

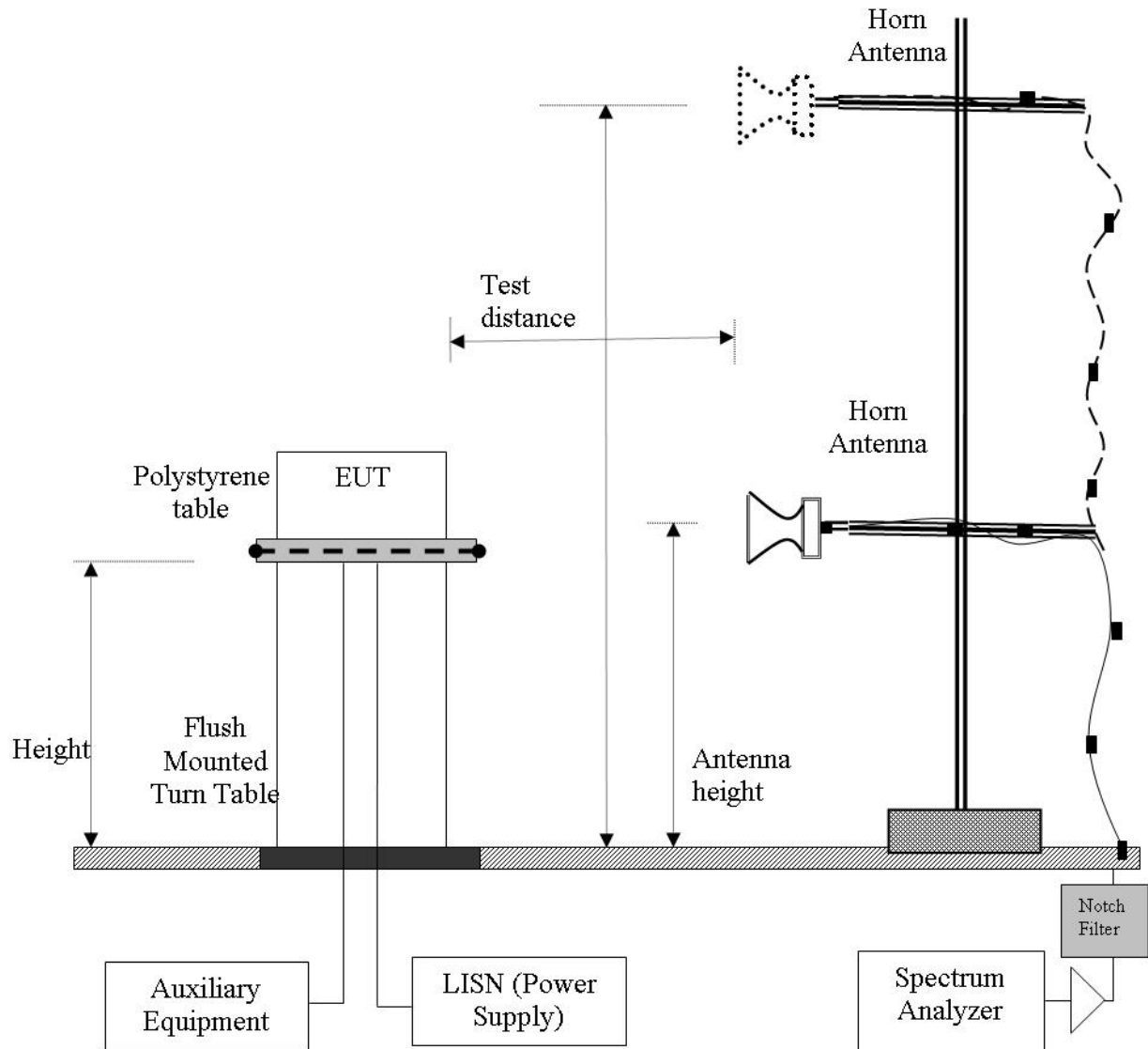

This test report may be reproduced in full only. The document may only be updated by MiCOM Labs personnel. Any changes will be noted in the Document History section of the report.

Radiated Emission Measurement Setup – Below 1 GHz

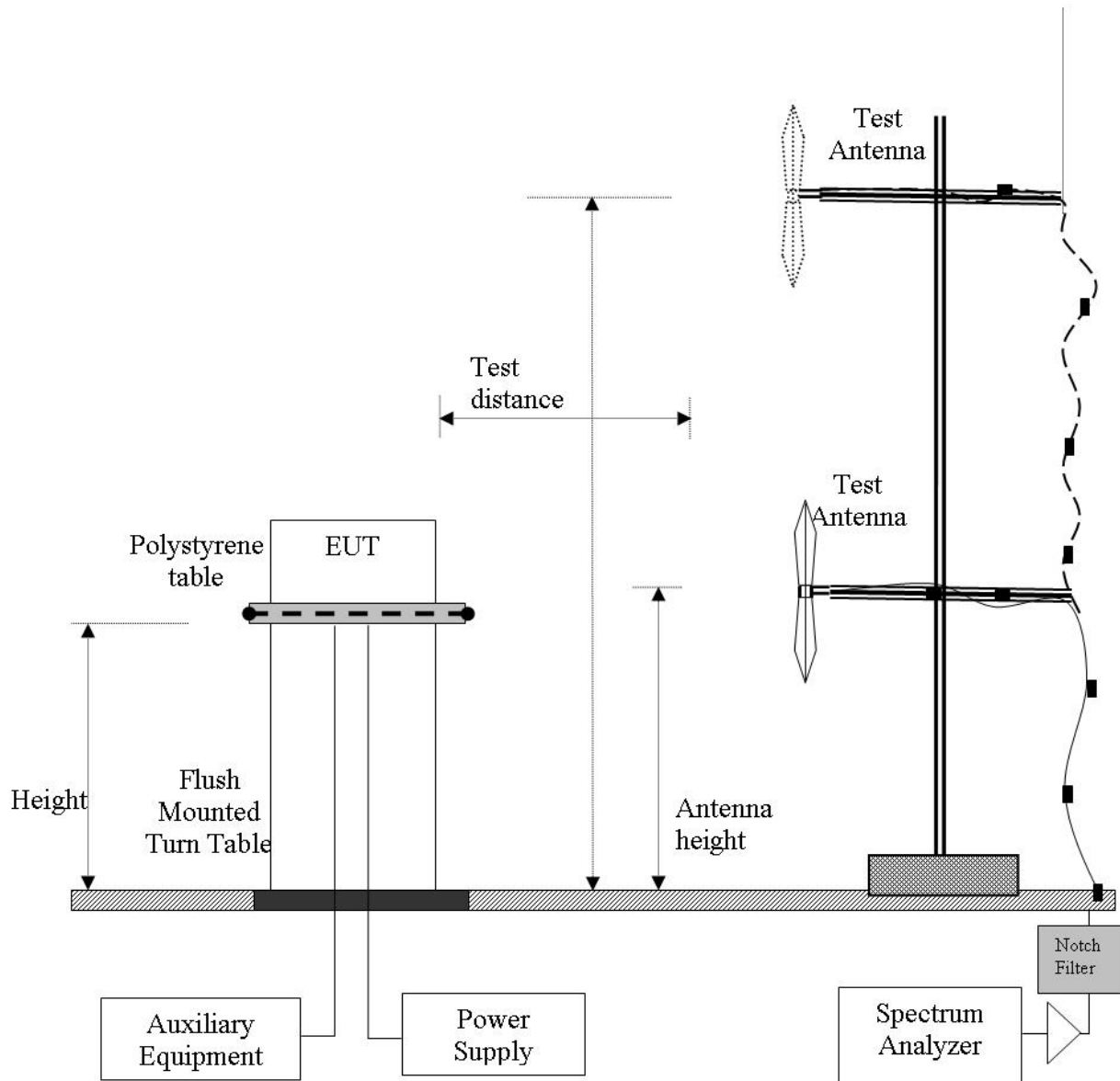

This test report may be reproduced in full only. The document may only be updated by MiCOM Labs personnel. Any changes will be noted in the Document History section of the report.



Title: Rabbit MiniCore RCM66XXW
To: FCC 47 CFR Part 15.247 & RSS-210
Serial #: DIGI25-U1 Rev A
Issue Date: 29th February 2012
Page: Page 64 of 91

Field Strength Calculation

The field strength is calculated by adding the Antenna Factor and Cable Loss, and subtracting Amplifier Gain from the measured reading. All factors are included in the reported data.

$$FS = R + AF + CORR - FO$$

FS = Field Strength
R = Measured Spectrum analyzer Input Amplitude
AF = Antenna Factor

$$CORR = \text{Correction Factor} = CL - AG + NFL$$

CL = Cable Loss
AG = Amplifier Gain
FO = Distance Falloff Factor
NFL = Notch Filter Loss or Waveguide Loss

Field Strength Calculation Example:

Given receiver input reading of 51.5 dB μ V; Antenna Factor of 8.5 dB; Cable Loss of 1.3 dB; Falloff Factor of 0 dB, an Amplifier Gain of 26 dB and Notch Filter Loss of 1 dB. The Field Strength of the measured emission is:

$$FS = 51.5 + 8.5 + 1.3 - 26.0 + 1 = 36.3 \text{ dB}\mu\text{V/m}$$

Conversion between dB μ V/m (or dB μ V) and μ V/m (or μ V) are done as:

$$\text{Level (dB}\mu\text{V/m)} = 20 * \text{Log (level (\mu\text{V/m}))}$$

$$\begin{aligned} 40 \text{ dB}\mu\text{V/m} &= 100 \mu\text{V/m} \\ 48 \text{ dB}\mu\text{V/m} &= 250 \mu\text{V/m} \end{aligned}$$

This test report may be reproduced in full only. The document may only be updated by MiCOM Labs personnel. Any changes will be noted in the Document History section of the report.



Specification for FCC Part 15 Radiated Spurious Emissions

FCC §15.247(d) In any 100 kHz bandwidth outside the frequency band in which the spread spectrum or digitally modulated intentional radiator is operating, the radio frequency power that is produced by the intentional radiator shall be at least 20 dB below that in the 100 kHz bandwidth within the band that contains the highest level of the desired power, based on either an RF conducted or radiated measurement, provided the transmitter demonstrates compliance with the peak conducted power limits.

If the transmitter complies with the conducted power limits based on the use of RMS averaging over a time interval, as permitted under paragraph (b)(3) of this section, the attenuation required under this paragraph shall be 30 dB instead of 20 dB. Attenuation below the general limits specified §15.209(a) is not required. In addition, radiated emissions which fall in the restricted bands, as defined in Section §15.205(a), must also comply with the radiated emission limits specified in Section 15.209(a) (see Section 15.205(a)).

FCC §15.205 (a) Except as shown in paragraph (d) of 15.205 (a), only spurious emissions are permitted in any of the frequency bands listed.

FCC §15.205 (a) Except as shown in paragraphs (d) and (e) of this section, the field strength of emissions appearing within these frequency bands shall not exceed the limits shown in Section §15.209. At frequencies equal to or less than 1000 MHz, compliance with the limits in Section 15.209 shall be demonstrated using measurement instrumentation employing a CISPR quasi-peak detector. Above 1000 MHz, compliance with the emission limits in Section 15.209 shall be demonstrated based on the average value of the measured emissions. The provisions in Section 15.35 apply to these measurements.

FCC §15.209 (a) Except as provided elsewhere in this subpart, the emissions from an intentional radiator shall not exceed the field strength levels specified in the following table.

Table 1: FCC 15.209 Spurious Emissions Limits

Frequency (MHz)	Field Strength (µV/m)	Field Strength (dBµV/m)	Measurement Distance (meters)
30-88	100	40.0	3
88-216	150	43.5	3
216-960	200	46.0	3
Above 960	500	54.0	3



Title: Rabbit MiniCore RCM66XXW
To: FCC 47 CFR Part 15.247 & RSS-210
Serial #: DIGI25-U1 Rev A
Issue Date: 29th February 2012
Page: Page 66 of 91

Specification for Industry Canada RSS-210 Radiated Spurious Emissions

RSS-210 §2.1 RSS-Gen Compliance

In addition to RSS-210, the requirements in RSS-Gen, General Requirements and Information for the Certification of Radio Apparatus, must be met.

RSS-210 §2.2 Emissions Falling Within Restricted Frequency Bands

Category I license-exempt equipment is required to comply with the provisions in RSS-Gen with respect to emissions falling within restricted frequency bands. These restricted frequency bands are listed in RSS-Gen.

RSS-210 §2.3 Receivers

Category I equipment receivers for use with transmitters subject to RSS-210 must comply with the applicable requirements set out in RSS-Gen and be certified under RSS-210. Category II equipment receivers for use with transmitters subject to RSS-210 are exempt from certification, but are subject to compliance with RSS-Gen and RSS-310.

RSS-210 §2.5 General Field Strength Limits

RSS-Gen includes the general field strength limits of unwanted emissions, where applicable, for transmitters and receivers operating in accordance with the provisions specified in this standard.

Unwanted emissions of transmitters and receivers are permitted to fall within the restricted bands listed in RSS-Gen, and including the TV bands, but fundamental emissions are prohibited in the restricted bands.

This test report may be reproduced in full only. The document may only be updated by MiCOM Labs personnel. Any changes will be noted in the Document History section of the report.



Specification for Industry Canada RSS-Gen Radiated Transmitter Spurious Emissions

RSS-Gen §7.2.5 Transmitter Spurious Emissions Limits

Spurious emissions from license-exempt transmitters shall comply with the field strength limits shown below. Additionally, the level of any transmitter spurious emission shall not exceed the level of the transmitter's fundamental emission.

Table 1: RSS-Gen §7.2.5 Radiated Transmitter Spurious Emissions Limits

Frequency (MHz)	Field Strength ($\mu\text{V/m}$)	Field Strength ($\text{dB}\mu\text{V/m}$)	Measurement Distance (meters)
30-88	100	40.0	3
88-216	150	43.5	3
216-960	200	46.0	3
Above 960	500	54.0	3

Specification for Industry Canada RSS-Gen Radiated Receiver Spurious Emissions

RSS-Gen §6.1 Receiver Spurious Emissions Limits

Radiated spurious emission measurements shall be performed with the receiver antenna connected to the receiver antenna terminals.

Spurious emissions from receivers shall not exceed the radiated limits shown in the table below.

Table 1: RSS-Gen §6.1 Radiated Receiver Spurious Emissions Limits

Frequency (MHz)	Field Strength ($\mu\text{V/m}$)	Field Strength ($\text{dB}\mu\text{V/m}$)	Measurement Distance (meters)
30-88	100	40.0	3
88-216	150	43.5	3
216-960	200	46.0	3
Above 960	500	54.0	3



Title: Rabbit MiniCore RCM66XXW
To: FCC 47 CFR Part 15.247 & RSS-210
Serial #: DIGI25-U1 Rev A
Issue Date: 29th February 2012
Page: Page 68 of 91

Laboratory Measurement Uncertainty for Spectrum Measurement

Measurement Uncertainty	+5.6/ -4.5 dB
--------------------------------	---------------

Traceability:

Method	Test Equipment Used
Work instruction WI-03	0287, 0193, 0342, 0158, 0303, 0304, 0134, 0310, 0312

This test report may be reproduced in full only. The document may only be updated by MiCOM Labs personnel. Any changes will be noted in the Document History section of the report.



7.6.1 Transmitter Radiated Spurious Emissions

All frequencies and modes were checked per 15.247 for radio emissions below 1GHz.

Test Freq.	N/A	Engineer	GMH
Variant	Digital Emissions	Temp (°C)	19
Freq. Range	30 MHz - 1000 MHz	Rel. Hum.(%)	38
Power Setting	N/A	Press. (mBars)	1009
Antenna	Dipole 1.8 dBi		
Test Notes 1			
Test Notes 2	Rx: Ch.		

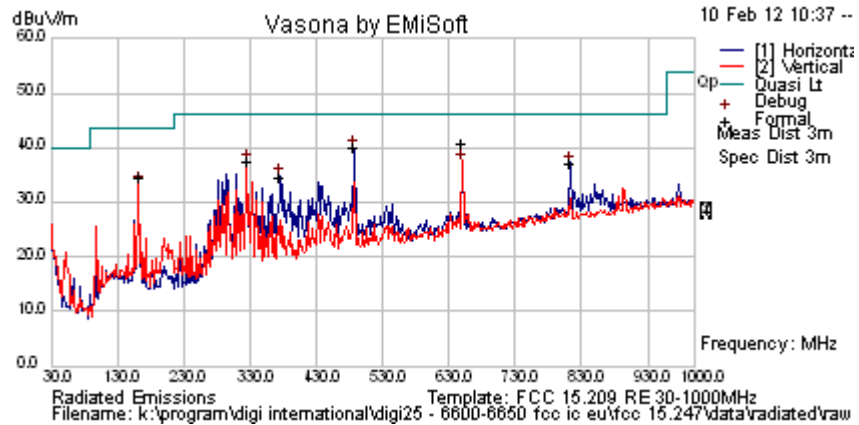

Formally measured emission peaks

Frequency MHz	Raw dBuV	Cable Loss	AF dB	Level dBuV/m	Measurement Type	Pol	Hgt cm	Azt Deg	Limit dBuV/m	Margin dB	Pass /Fail	Comments
487.495	46.6	6.0	-12.4	40.2	Quasi Max	H	211	165	46	-5.8	Pass	
650.003	44.4	6.5	-10.2	40.8	Quasi Max	H	132	315	46.0	-5.2	Pass	
324.997	48.4	5.3	-16.1	37.6	Quasi Max	H	100	14	46.0	-8.4	Pass	
812.496	37.9	7.2	-8.1	37.0	Quasi Max	H	98	276	46.0	-9.0	Pass	
162.499	48.4	4.6	-18.4	34.6	Quasi Max	V	98	238	43.5	-9.0	Pass	
375.869	43.9	5.6	-15.0	34.4	Peak [Scan]	V	98	238	46.0	-11.6	Pass	

Legend: DIG = Digital Device Emission; TX = Transmitter Emission; FUND = Fundamental Frequency
 NRB = Non-Restricted Band, Limit is 20 dB below Fundamental; RB = Restricted Band

The above plot implements a peak detector showing both polarities.

No emissions were found within 6 dB of the limit

This test report may be reproduced in full only. The document may only be updated by MiCOM Labs personnel. Any changes will be noted in the Document History section of the report.



Title: Rabbit MiniCore RCM66XXW
To: FCC 47 CFR Part 15.247 & RSS-210
Serial #: DIGI25-U1 Rev A
Issue Date: 29th February 2012
Page: Page 70 of 91

Digital Emissions 1 – 6 GHz

Test Freq.	N/A	Engineer	GMH
Variant	Digital Emissions	Temp (°C)	19
Freq. Range	1000 MHz - 6000 MHz	Rel. Hum.(%)	33
Power Setting	N/A	Press. (mBars)	1000
Antenna	Dipole 1.8 dBi		
Test Notes 1			
Test Notes 2	Rx: Ch.		

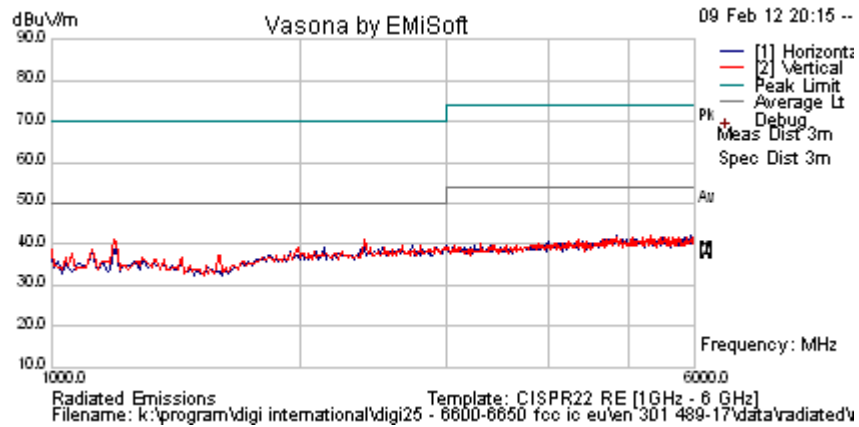

Formally measured emission peaks

Frequency MHz	Raw dBuV	Cable Loss	AF dB	Level dBuV/m	Measurement Type	Pol	Hgt cm	Azt Deg	Limit dBuV/m	Margin dB	Pass /Fail	Comments
No emissions found within 6 dB of the limit line												
Legend: DIG = Digital Device Emission; TX = Transmitter Emission; FUND = Fundamental Frequency NRB = Non-Restricted Band, Limit is 20 dB below Fundamental; RB = Restricted Band												

The above plot implements a peak detector showing both polarities.

This test report may be reproduced in full only. The document may only be updated by MiCOM Labs personnel. Any changes will be noted in the Document History section of the report.



Title: Rabbit MiniCore RCM66XXW
To: FCC 47 CFR Part 15.247 & RSS-210
Serial #: DIGI25-U1 Rev A
Issue Date: 29th February 2012
Page: Page 71 of 91

Test Freq.	2412 MHz	Engineer	GMH
Variant	802.11b; 1 Mbs	Temp (°C)	21
Freq. Range	1000 MHz - 18000 MHz	Rel. Hum.(%)	39
Power Setting	Pwr reduced from 57 to 49	Press. (mBars)	1006
Antenna	Dipole 1.8 dBi	Duty Cycle (%)	100
Test Notes 1	Reduction in power required due to 2nd harmonic issue		
Test Notes 2			

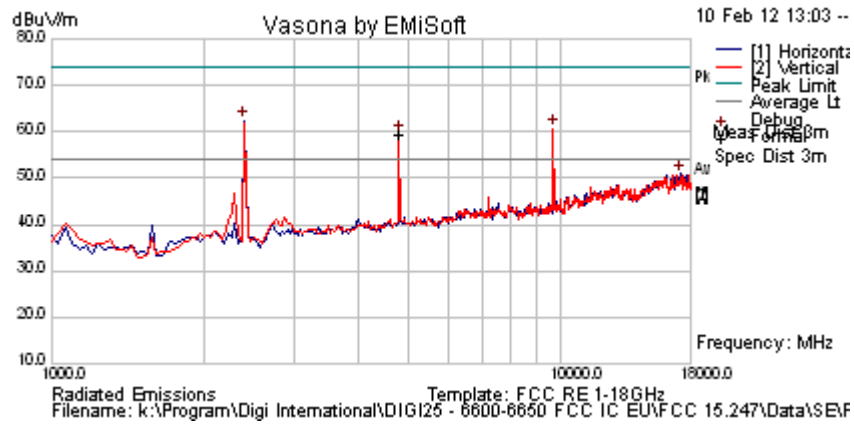

Formally measured emission peaks

Frequency MHz	Raw dBuV	Cable Loss	AF dB	Level dBuV/m	Measurement Type	Pol	Hgt cm	Azt Deg	Limit dBuV/m	Margin dB	Pass /Fail	Comments
4824.0	61.5	4.5	-9.7	56.3	Peak	V	146	10	74	-17.73	Pass	RB
4824.0	59.1	4.5	-9.7	53.9	Average.	V	146	10	54	-0.1	Pass	RB
2396.794	71.2	3.0	-11.7	62.5	Peak [Scan]	H						FUND
9653.307	58.0	6.3	-3.5	60.7	Peak [Scan]	V					Pass	NRB
17114.228	42.0	8.5	0.5	51.0	Peak [Scan]	H	100	0	54	-2.99	Pass	NOISE

Legend: TX = Transmitter Emissions; DIG = Digital Emissions; FUND = Fundamental; WB = Wideband Emission
 RB = Restricted Band (15.209 Limits); NRB = Non Restricted Band, Limit is 20dB below fundamental peak

The above plot implements a peak detector showing both polarities.

This test report may be reproduced in full only. The document may only be updated by MiCOM Labs personnel. Any changes will be noted in the Document History section of the report.



Title: Rabbit MiniCore RCM66XXW
To: FCC 47 CFR Part 15.247 & RSS-210
Serial #: DIGI25-U1 Rev A
Issue Date: 29th February 2012
Page: Page 72 of 91

Test Freq.	2437 MHz	Engineer	GMH
Variant	802.11b; 1 Mbs	Temp (°C)	21
Freq. Range	1000 MHz - 18000 MHz	Rel. Hum.(%)	39
Power Setting	Pwr reduced from 57 to 49	Press. (mBars)	1006
Antenna	Dipole 1.8 dBi	Duty Cycle (%)	100
Test Notes 1	Reduction in power required due to 2nd harmonic issue		
Test Notes 2			

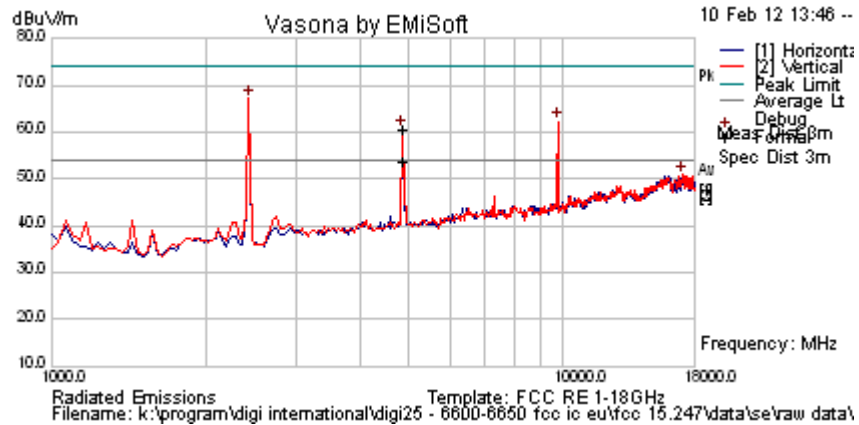

Formally measured emission peaks

Frequency MHz	Raw dBuV	Cable Loss	AF dB	Level dBuV/m	Measurement Type	Pol	Hgt cm	Azt Deg	Limit dBuV/m	Margin dB	Pass /Fail	Comments
4874.007	65.9	4.5	-9.7	60.7	Peak Max	V	99	124	74.0	-13.3	Pass	RB
4874.007	58.9	4.5	-9.7	53.7	Average	V	99	124	54.0	-0.3	Pass	RB
2430.862	75.9	3.0	-11.6	67.3	Peak [Scan]	H						FUND
9755.51102	59.6	6.4	-3.7	62.2	Peak [Scan]	V					Pass	NRB
17114.228	41.8	8.5	0.5	50.8	Peak [Scan]	V					Pass	NOISE

Legend: TX = Transmitter Emissions; DIG = Digital Emissions; FUND = Fundamental; WB = Wideband Emission
 RB = Restricted Band (15.209 Limits); NRB = Non Restricted Band, Limit is 20dB below fundamental peak

The above plot implements a peak detector showing both polarities.

This test report may be reproduced in full only. The document may only be updated by MiCOM Labs personnel. Any changes will be noted in the Document History section of the report.



Title: Rabbit MiniCore RCM66XXW
To: FCC 47 CFR Part 15.247 & RSS-210
Serial #: DIGI25-U1 Rev A
Issue Date: 29th February 2012
Page: Page 73 of 91

Test Freq.	2462 MHz	Engineer	GMH
Variant	802.11b; 1 Mbs	Temp (°C)	21
Freq. Range	1000 MHz - 18000 MHz	Rel. Hum.(%)	39
Power Setting	Power reduced from 56 to 42	Press. (mBars)	1006
Antenna	Dipole 1.8 dBi	Duty Cycle (%)	100
Test Notes 1	Reduction in power required due to 2nd harmonic issue		
Test Notes 2			

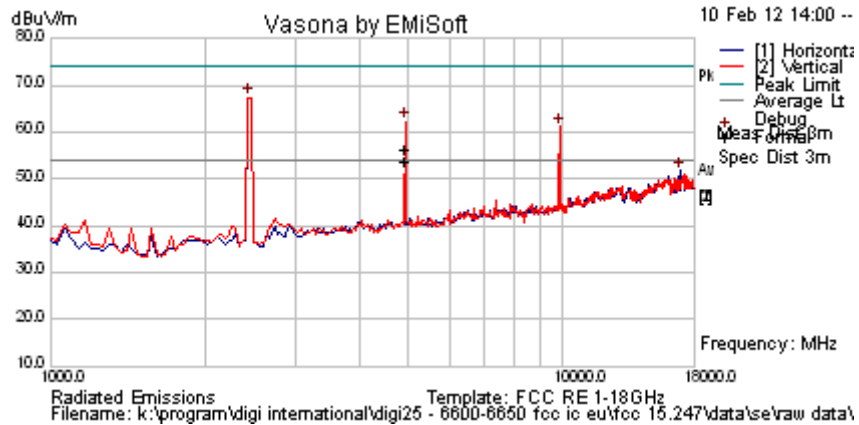

Formally measured emission peaks

Frequency MHz	Raw dBuV	Cable Loss	AF dB	Level dBuV/m	Measurement Type	Pol	Hgt cm	Azt Deg	Limit dBuV/m	Margin dB	Pass /Fail	Comments
4923.937	61.5	4.6	-9.8	56.2	Peak	V	131	0	74	-17.8	Pass	RB
4923.937	59.1	4.6	-9.8	53.9	Average	V	131	0	54	-0.1	Pass	RB
2430.862	75.9	3.0	-11.6	67.3	Peak [Scan]	V						FUND
9857.715	58.3	6.4	-3.5	61.2	Peak [Scan]	V					Pass	NRB
16875.752	42.6	8.6	0.7	51.8	Peak [Scan]	H	100	0	54	-2.2	Pass	NOISE

Legend: TX = Transmitter Emissions; DIG = Digital Emissions; FUND = Fundamental; WB = Wideband Emission
 RB = Restricted Band (15.209 Limits); NRB = Non Restricted Band, Limit is 20dB below fundamental peak

The above plot implements a peak detector showing both polarities. The emission breaking the limit line is the fundamental frequency.

This test report may be reproduced in full only. The document may only be updated by MiCOM Labs personnel. Any changes will be noted in the Document History section of the report.



Title: Rabbit MiniCore RCM66XXW
To: FCC 47 CFR Part 15.247 & RSS-210
Serial #: DIGI25-U1 Rev A
Issue Date: 29th February 2012
Page: Page 74 of 91

Test Freq.	2412 MHz	Engineer	GMH
Variant	802.11g; 6 Mbs	Temp (°C)	21
Freq. Range	1000 MHz - 18000 MHz	Rel. Hum.(%)	39
Power Setting	58	Press. (mBars)	1006
Antenna	Dipole 1.8 dBi	Duty Cycle (%)	100
Test Notes 1			
Test Notes 2			

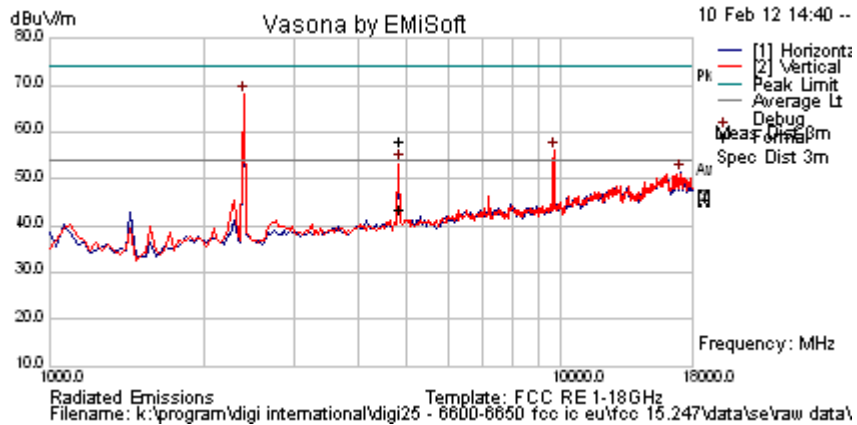

Formally measured emission peaks

Frequency MHz	Raw dBuV	Cable Loss	AF dB	Level dBuV/m	Measurement Type	Pol	Hgt cm	Azt Deg	Limit dBuV/m	Margin dB	Pass /Fail	Comments
4824.073	63.1	4.5	-9.7	57.9	Peak Max	V	138	6	74.0	-16.1	Pass	RB
4824.073	48.8	4.5	-9.7	43.6	Average Max	V	138	6	54	-10.4	Pass	RB
2396.794	76.6	3.0	-11.7	67.9	Peak [Scan]	V						FUND
9653.30661	53.2	6.3	-3.5	56.0	Peak [Scan]	V					Pass	NRB
17114.228	42.3	8.5	0.5	51.3	Peak [Scan]	H	100	0	54	-2.8	Pass	NOISE

Legend: TX = Transmitter Emissions; DIG = Digital Emissions; FUND = Fundamental; WB = Wideband Emission
 RB = Restricted Band (15.209 Limits); NRB = Non Restricted Band, Limit is 20dB below fundamental peak

The above plot implements a peak detector showing both polarities.

This test report may be reproduced in full only. The document may only be updated by MiCOM Labs personnel. Any changes will be noted in the Document History section of the report.



Title: Rabbit MiniCore RCM66XXW
To: FCC 47 CFR Part 15.247 & RSS-210
Serial #: DIGI25-U1 Rev A
Issue Date: 29th February 2012
Page: Page 75 of 91

Test Freq.	2437 MHz	Engineer	GMH
Variant	802.11g; 6 Mbs	Temp (°C)	21
Freq. Range	1000 MHz - 18000 MHz	Rel. Hum.(%)	39
Power Setting	62	Press. (mBars)	1006
Antenna	Dipole 1.8 dBi	Duty Cycle (%)	100
Test Notes 1			
Test Notes 2			

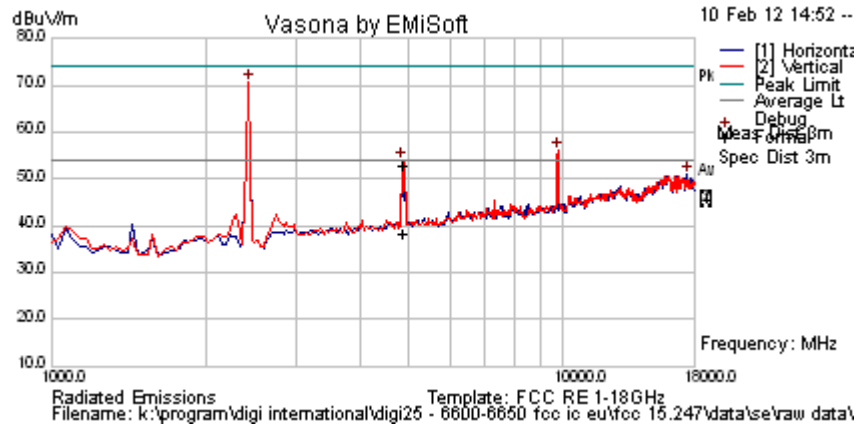

Formally measured emission peaks

Frequency MHz	Raw dBuV	Cable Loss	AF dB	Level dBuV/m	Measurement Type	Pol	Hgt cm	Azt Deg	Limit dBuV/m	Margin dB	Pass /Fail	Comments
4882.798	58.2	4.5	-9.7	53.0	Peak Max	V	146	134	74	-21.0	Pass	RB
4882.798	43.5	4.5	-9.7	38.3	Average Max	V	146	134	54	-15.7	Pass	RB
2430.862	79.2	3.0	-11.6	70.6	Peak [Scan]	V						FUND
9755.511	53.4	6.4	-3.7	56.0	Peak [Scan]	V					Pass	NRB
17454.910	41.1	8.7	1.2	51.0	Peak [Scan]	H					Pass	NOISE
Legend: TX = Transmitter Emissions; DIG = Digital Emissions; FUND = Fundamental; WB = Wideband Emission RB = Restricted Band (15.209 Limits); NRB = Non Restricted Band, Limit is 20dB below fundamental peak												

The above plot implements a peak detector showing both polarities. The emission breaking the limit line is the fundamental frequency.

This test report may be reproduced in full only. The document may only be updated by MiCOM Labs personnel. Any changes will be noted in the Document History section of the report.



Title: Rabbit MiniCore RCM66XXW
To: FCC 47 CFR Part 15.247 & RSS-210
Serial #: DIGI25-U1 Rev A
Issue Date: 29th February 2012
Page: Page 76 of 91

Test Freq.	2462 MHz	Engineer	GMH
Variant	802.11g; 6 Mbs	Temp (°C)	21
Freq. Range	1000 MHz - 18000 MHz	Rel. Hum.(%)	39
Power Setting	46	Press. (mBars)	1006
Antenna	Dipole 1.8 dBi	Duty Cycle (%)	100
Test Notes 1			
Test Notes 2			

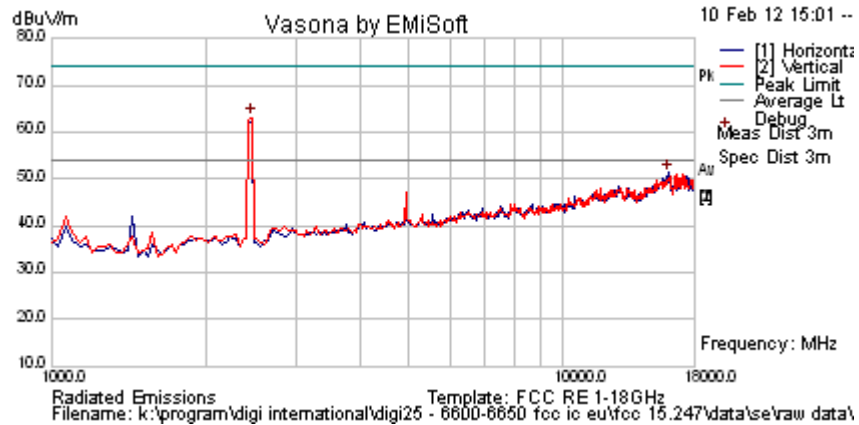

Formally measured emission peaks

Frequency MHz	Raw dBuV	Cable Loss	AF dB	Level dBuV/m	Measurement Type	Pol	Hgt cm	Azt Deg	Limit dBuV/m	Margin dB	Pass /Fail	Comments
2464.930	71.6	3.0	-11.5	63.1	Peak [Scan]	V						FUND
15989.98	42.1	9.0	0.1	51.3	Peak [Scan]						Pass	NOISE
Legend: TX = Transmitter Emissions; DIG = Digital Emissions; FUND = Fundamental; WB = Wideband Emission RB = Restricted Band (15.209 Limits); NRB = Non Restricted Band, Limit is 20dB below fundamental peak												

The above plot implements a peak detector showing both polarities. The emission breaking the limit line is the fundamental frequency.

This test report may be reproduced in full only. The document may only be updated by MiCOM Labs personnel. Any changes will be noted in the Document History section of the report.



7.6.2 Band-Edge Measurements

Band-Edge 2412MHz; 802.11b 2310-2390 MHz

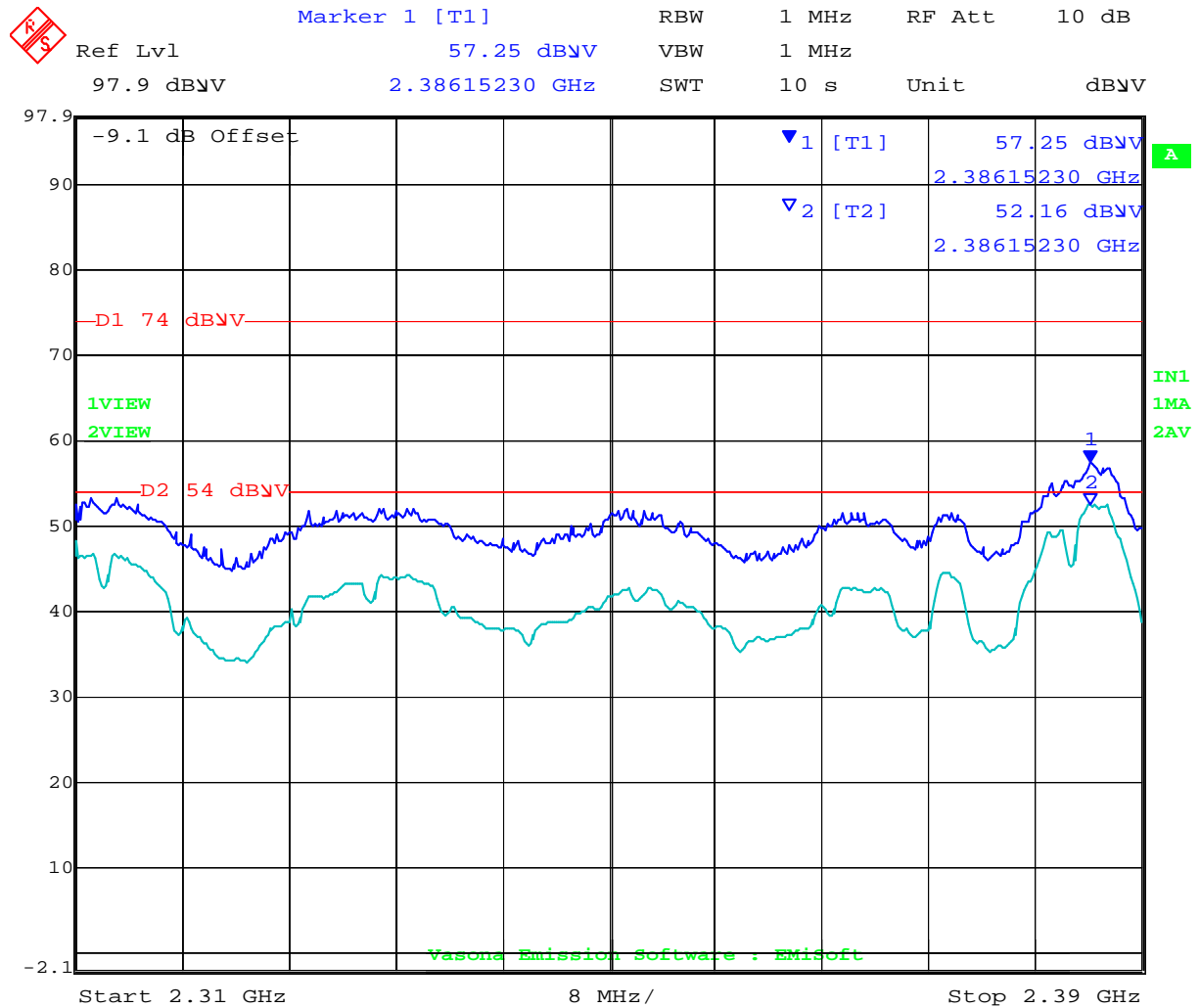

Date: 10.FEB.2012 10:59:33

This test report may be reproduced in full only. The document may only be updated by MiCOM Labs personnel. Any changes will be noted in the Document History section of the report.



Band-Edge 2462MHz; 802.11b 2483.5 - 2500 MHz

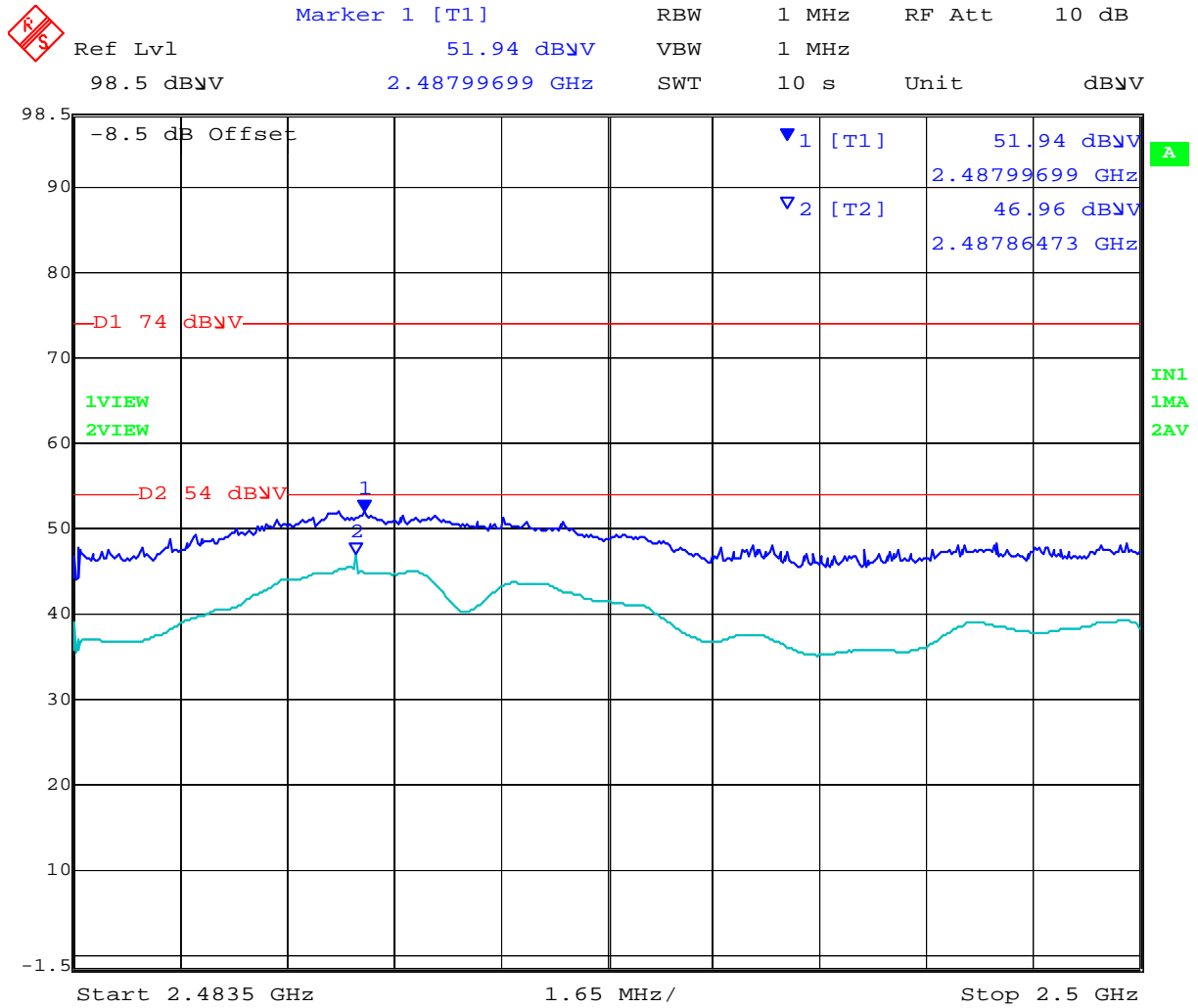

Date: 10.FEB.2012 11:11:35

This test report may be reproduced in full only. The document may only be updated by MiCOM Labs personnel. Any changes will be noted in the Document History section of the report.



Band-Edge 2412MHz; 802.11g 2310-2390 MHz

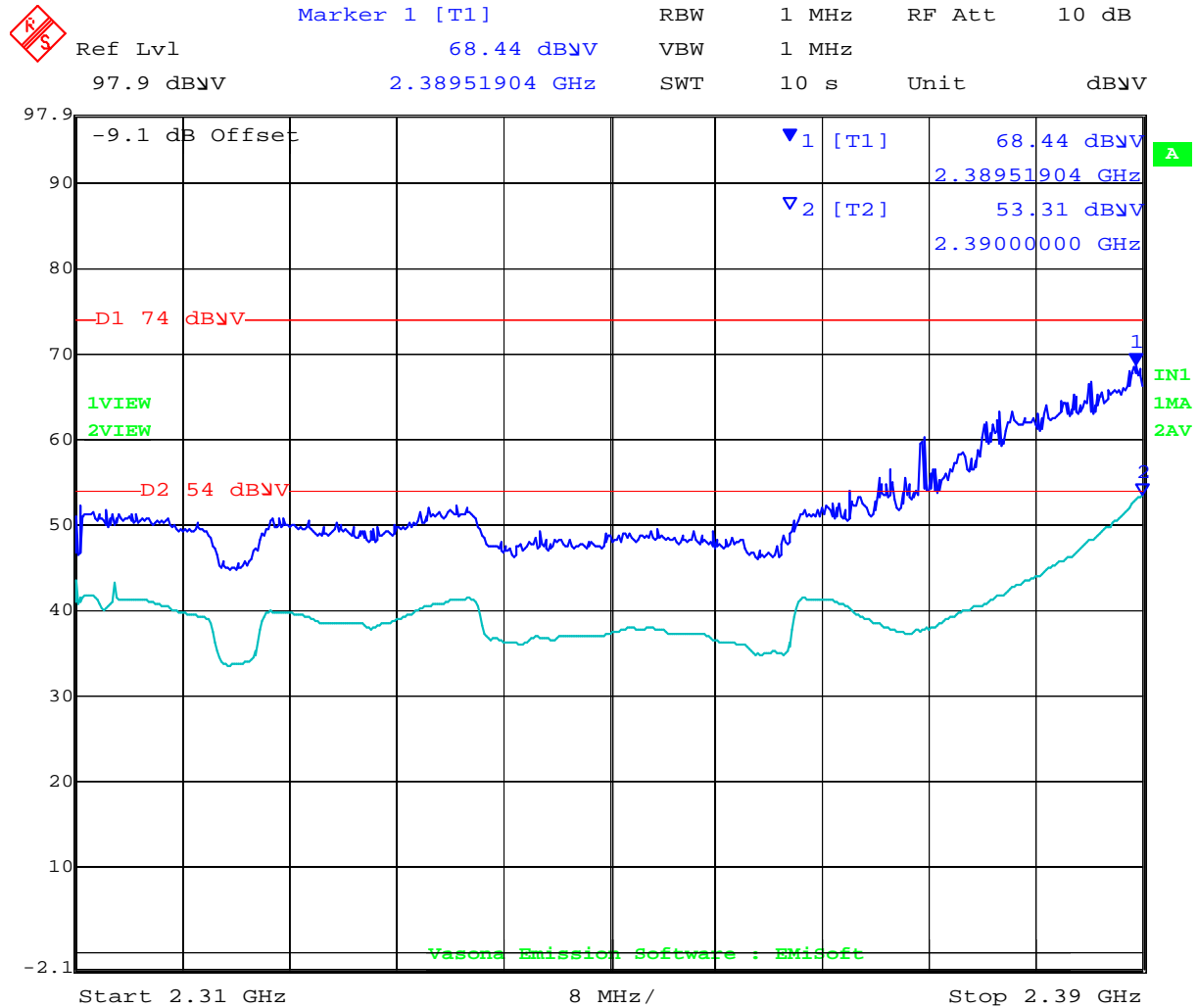

Date: 10.FEB.2012 11:05:48

This test report may be reproduced in full only. The document may only be updated by MiCOM Labs personnel. Any changes will be noted in the Document History section of the report.



Band-Edge 2462MHz; 802.11g 2483.5 - 2500 MHz

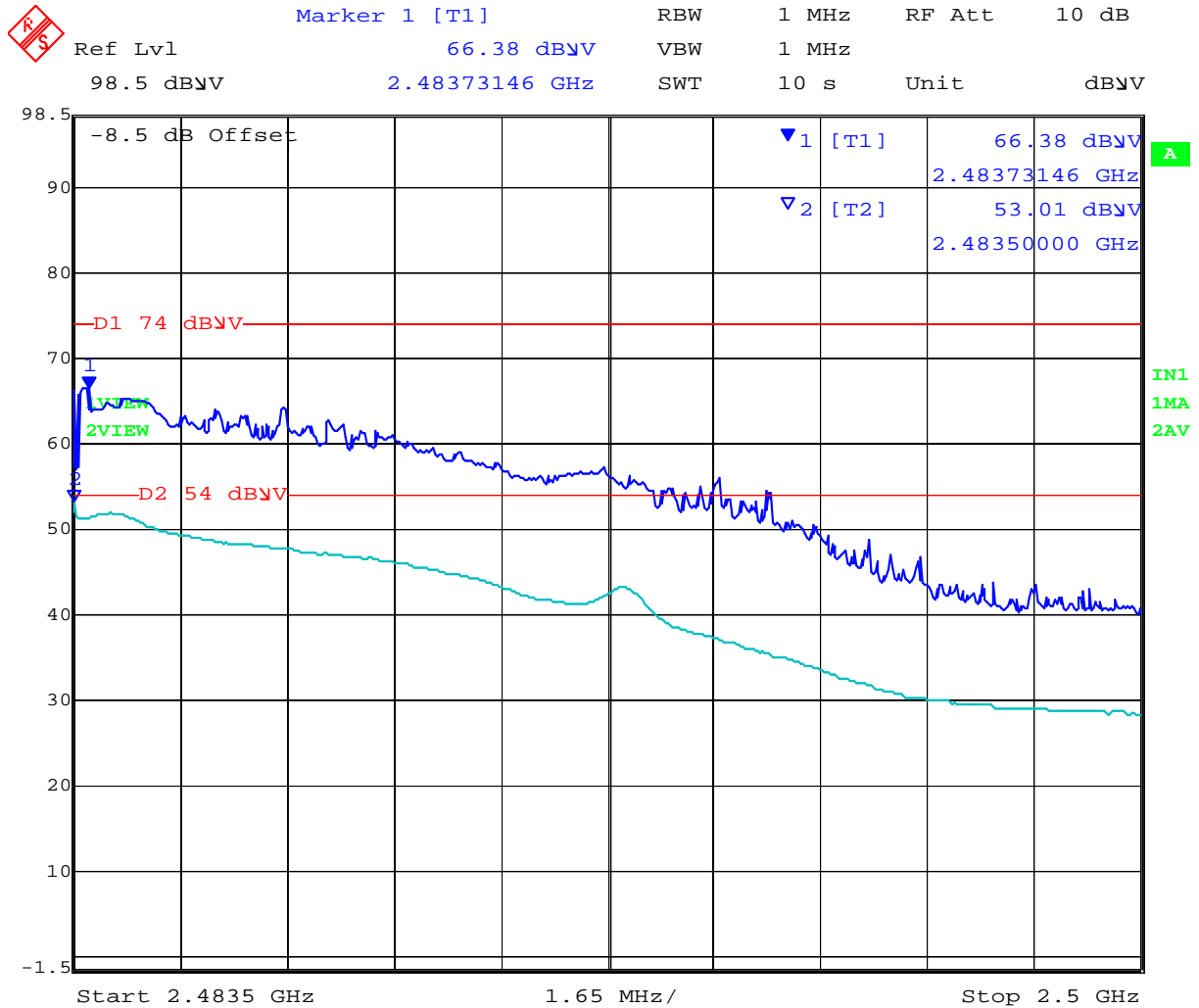

Date: 10.FEB.2012 11:23:07

Power reduction required in order to comply with band-edge requirements

This test report may be reproduced in full only. The document may only be updated by MiCOM Labs personnel. Any changes will be noted in the Document History section of the report.



7.6.3 Receiver Radiated Emissions

Measurement Results for Radiated Spurious Emissions – Receiver

Test Freq.	2472 MHz	Engineer	GMH
Variant	Receive in Test Utility	Temp (°C)	21.5
Freq. Range	1 - 12.75 GHz	Rel. Hum.(%)	39
Power Setting	Not Applicable in Receive Mode	Press. (mBars)	1008
Antenna	1.8 dBi Dipole		
Test Notes 1			
Test Notes 2			

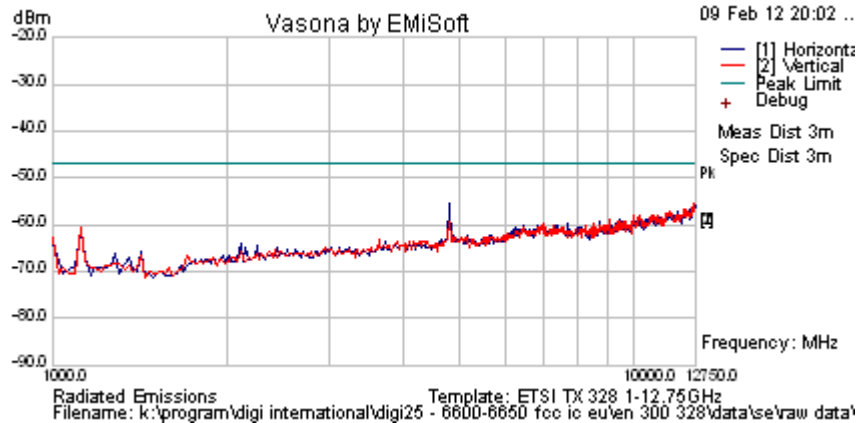

Formally measured emission peaks

Frequency MHz	Raw dBuV	Cable Loss	AF dB	Level dBuV/m	Measurement Type	Pol	Hgt cm	Azt Deg	Limit dBuV/m	Margin dB	Pass /Fail	Comments
No emissions found within 6 dB of the limit line												
Legend: RX = Receiver Emissions; FUND = Fundamental Frequency												
ETSI 328 Measurement Type: 30 kHz RBW, 30 kHz VBW, 1 S sweep time, Peak Detector, Averaging Off												

This test report may be reproduced in full only. The document may only be updated by MiCOM Labs personnel. Any changes will be noted in the Document History section of the report.



Title: Rabbit MiniCore RCM66XXW
To: FCC 47 CFR Part 15.247 & RSS-210
Serial #: DIGI25-U1 Rev A
Issue Date: 29th February 2012
Page: Page 82 of 91

7.7 Conducted Disturbance at Mains Terminal (150 kHz – 30 MHz)

NOTE: Test not applicable EUT is a battery powered module

Test Procedure

The EUT is configured in accordance with ANSI C63.4. The conducted emissions are measured in a shielded room with a spectrum analyzer in peak hold in the first instance. Emissions closest to the limit are measured in the quasi-peak mode (QP) with the tuned receiver using a bandwidth of 9 kHz. The emissions are maximized further by cable manipulation. The highest emissions relative to the limit are listed.

If the average limit is met when using a quasi-peak detector receiver, the EUT shall be deemed to meet both limits and measurement with the average detector receiver is unnecessary.

If the reading of the measuring receiver shows fluctuations close to the limit, the reading shall be observed for at least 15 s at each measurement frequency; the higher reading shall be recorded with the exception of any brief isolated high reading which shall be ignored.

This test report may be reproduced in full only. The document may only be updated by MiCOM Labs personnel. Any changes will be noted in the Document History section of the report.

Test Measurement Setup

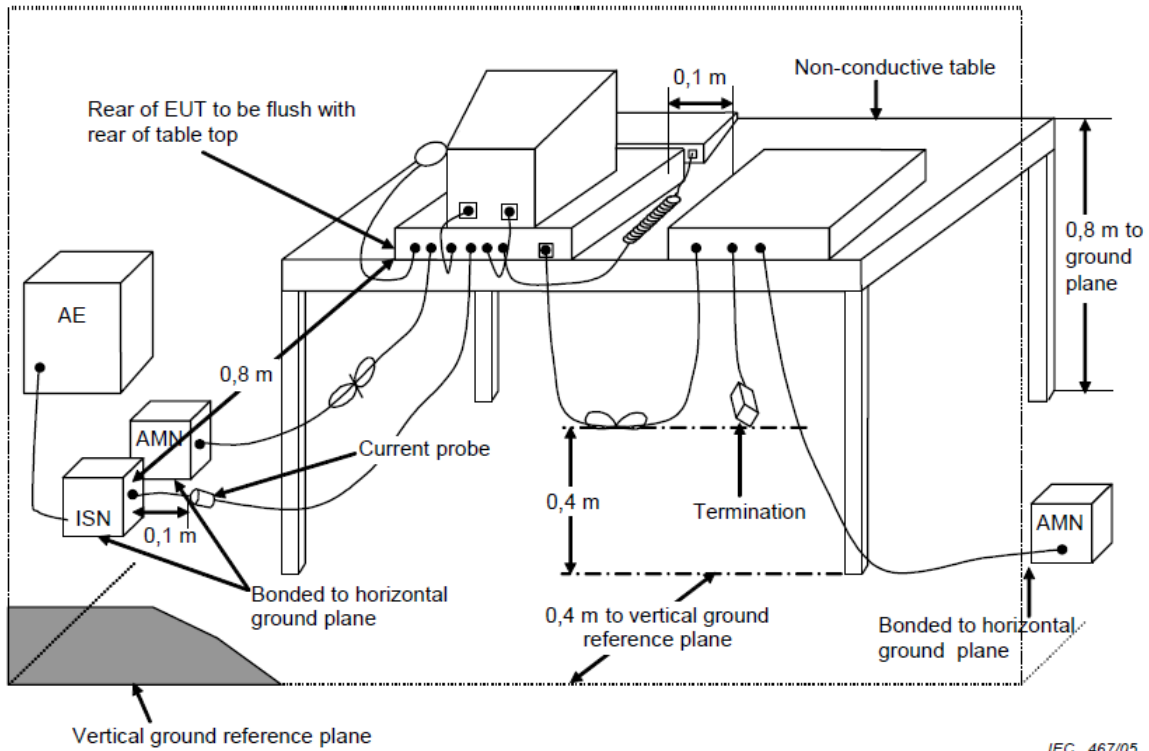

Measurement setup for Conducted Disturbance at Mains Terminals



Specification for Conducted Disturbance at Mains Terminal – Digital Apparatus

FCC §15.207 (a)

Except as shown in paragraphs (b) and (c) of this section, for an intentional radiator that is designed to be connected to the public utility (AC) power line, the radio frequency voltage that is conducted back onto the AC power line on any frequency or frequencies within the band 150 kHz to 30 MHz shall not exceed the limits in the following table, as measured using a 50 $\mu\Omega$ line impedance stabilization network (LISN), see §15.207 (a) matrix below. Compliance with the provisions of this paragraph shall be based on the measurement of the radio frequency voltage between each power line and ground at the power terminal.

RSS-GEN §7.2.4

AC Power Line Conducted Emissions Limits: Except when the requirements applicable to a given device state otherwise, for any radio apparatus equipped to operate from the public utility AC power supply, either directly or indirectly (such as with a battery charger), the radio frequency voltage of emissions conducted back onto the AC power lines in the frequency range of 0.15 MHz to 30 MHz shall not exceed the limits shown in the table below. The more stringent limit applies at the frequency range boundaries.

The conducted emissions shall be measured with a 50 ohm/50 microhenry line impedance stabilization network (LISN).

Limits

Frequency of Emission (MHz)	Conducted Limit (dB μ V)	
	Quasi-peak	Average
0.15-0.5	66 to 56*	56 to 46*
0.5-5	56	46
5-30	60	50

* Decreases with the logarithm of the frequency



Title: Rabbit MiniCore RCM66XXW
To: FCC 47 CFR Part 15.247 & RSS-210
Serial #: DIGI25-U1 Rev A
Issue Date: 29th February 2012
Page: Page 85 of 91

Traceability

Laboratory Measurement Uncertainty for Conducted Emissions

Measurement uncertainty	±2.64 dB
--------------------------------	----------

Traceability

Method	Test Equipment Used
Work instruction WI-EMC-01	0158, 0184, 0193, 0190, 0293, 0307

This test report may be reproduced in full only. The document may only be updated by MiCOM Labs personnel. Any changes will be noted in the Document History section of the report.

8 Photographs

8.1 Conducted RF Emissions - EUT

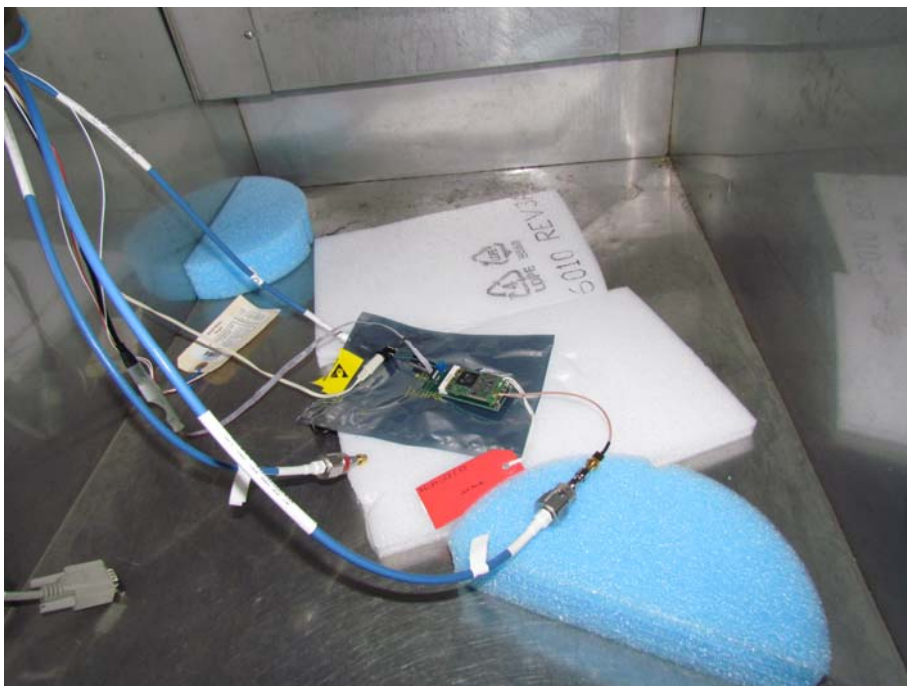

This test report may be reproduced in full only. The document may only be updated by MiCOM Labs personnel. Any changes will be noted in the Document History section of the report.

8.2 Transmitter Radiated Spurious Emission above 1 GHz



This test report may be reproduced in full only. The document may only be updated by MiCOM Labs personnel. Any changes will be noted in the Document History section of the report.

8.3 Transmitter Radiated Spurious Emission below 1 GHz



This test report may be reproduced in full only. The document may only be updated by MiCOM Labs personnel. Any changes will be noted in the Document History section of the report.

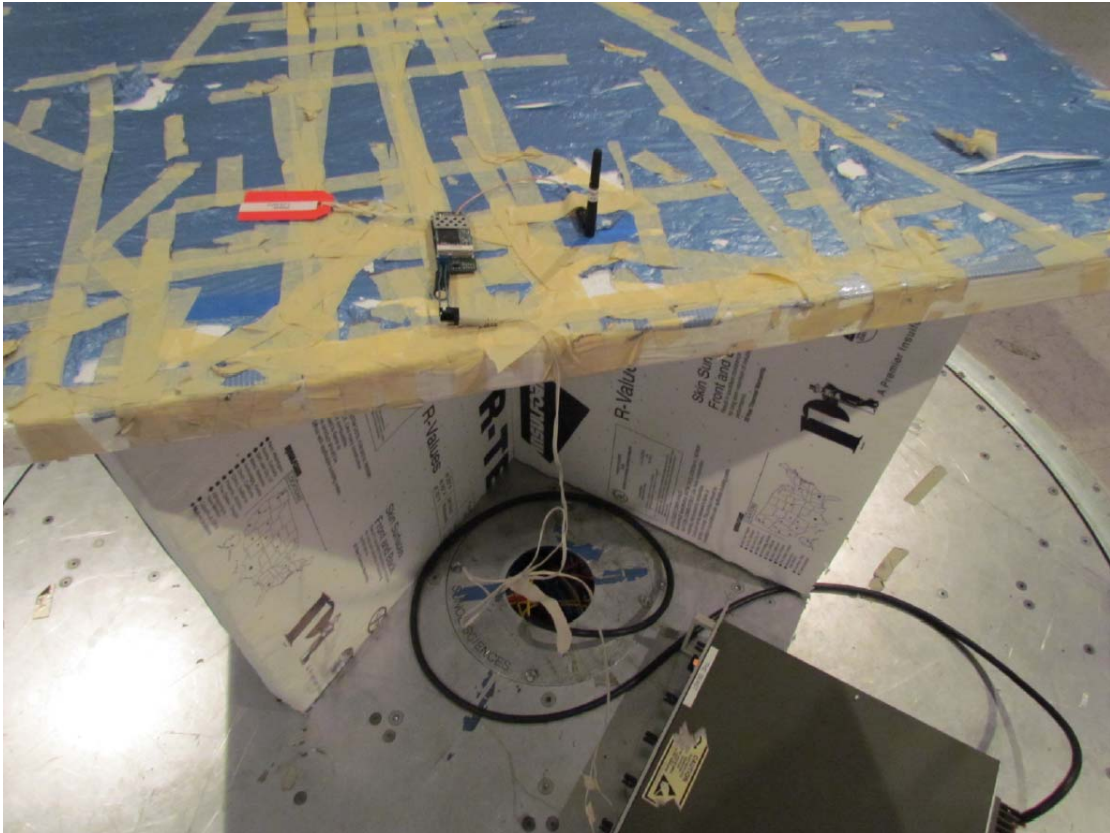

This test report may be reproduced in full only. The document may only be updated by MiCOM Labs personnel. Any changes will be noted in the Document History section of the report.



Title: Rabbit MiniCore RCM66XXW
To: FCC 47 CFR Part 15.247 & RSS-210
Serial #: DIGI25-U1 Rev A
Issue Date: 29th February 2012
Page: Page 90 of 91

9 TEST EQUIPMENT DETAILS

Asset #	Instrument	Manufacturer	Part #	Serial #
0134	Amplifier	Com Power	PA 122	181910
0158	Barometer /Thermometer	Control Co.	4196	E2846
0287	EMI Receiver	Rhode & Schwartz	ESIB 40	100201
0193	EMI Receiver	Rhode & Schwartz	ESIB 7	838496/007
0252	SMA Cable	Megaphase	Sucoflex 104	None
0310	2m SMA Cable	Micro-Coax	UFA210A-0-0787-3G03G0	209089-001
0312	3m SMA Cable	Micro-Coax	UFA210A-1-1181-3G0300	209092-001
0313	Coupler	Hewlett Packard	86205A	3140A01285
0314	30dB N-Type Attenuator	ARRA	N9444-30	1623
0070	Power Meter	Hewlett Packard	437B	3125U11552
0116	Power Sensor	Hewlett Packard	8485A	3318A19694
0117	Power Sensor	Hewlett Packard	8487D	3318A00371
0184	Pulse Limiter	Rhode & Schwartz	ESH3Z2	357.8810.52
0190	LISN	Rhode & Schwartz	ESH3Z5	836679/006
0293	BNC Cable	Megaphase	1689 1GVT4	15F50B001
0301	5.6 GHz Notch Filter	Micro-Tronics	RBC50704	001
0302	5.25 GHz Notch Filter	Micro-Tronics	BRC50703	002
0303	5.8 GHz Notch Filter	Micro-Tronics	BRC50705	003
0304	2.4GHzHz Notch Filter	Micro-Tronics	--	001
0307	BNC Cable	Megaphase	1689 1GVT4	15F50B002
0335	1-18GHz Horn Antenna	ETS- Lindgren	3117	00066580
0337	Amplifier	MiCOM Labs	--	--
0338	Antenna	Sunol Sciences	JB-3	A052907
0342	2.4 GHz Notch Filter	EWT	EWT-14-0203	H1

This test report may be reproduced in full only. The document may only be updated by MiCOM Labs personnel. Any changes will be noted in the Document History section of the report.



440 Boulder Court, Suite 200
Pleasanton, CA 94566, USA
Tel: 1.925.462.0304
Fax: 1.925.462.0306
www.micomlabs.com