



ConnectCore[®] 6UL

System-on-module solution

Hardware Reference Manual

Revision history—90001523

Revision	Date	Description
1P	May 2016	Preliminary document
2P	May 2016	Add reflow profiles
3P	June 2016	Revise bootstrap-GPIO configuration table; add new power supply architecture graphics; revise MCA pinout table
4P	August 2016	Revise pinout table, add new and revise graphics, update official weight, list Bluetooth 4.2, incorporate miscellaneous editorial corrections, remove "preliminary" designation
A	March 2017	Add power consumption, MCA, wireless interfaces, socket, assembly and product soldering, cryptoauthentication, bootstrap, and electrical characteristics sections; modify pinout tables; miscellaneous editorial revisions.

Trademarks and copyright

Digi, Digi International, and the Digi logo are trademarks or registered trademarks in the United States and other countries worldwide. All other trademarks mentioned in this document are the property of their respective owners.

© 2016 Digi International Inc. All rights reserved.

Disclaimers

Information in this document is subject to change without notice and does not represent a commitment on the part of Digi International. Digi provides this document “as is,” without warranty of any kind, expressed or implied, including, but not limited to, the implied warranties of fitness or merchantability for a particular purpose. Digi may make improvements and/or changes in this manual or in the product(s) and/or the program(s) described in this manual at any time.

Warranty

To view product warranty information, go to the following website:

www.digi.com/howtobuy/terms

Send comments

Documentation feedback: To provide feedback on this document, send your comments to techcomm@digi.com.

Customer support

Digi Technical Support: Digi offers multiple technical support plans and service packages to help our customers get the most out of their Digi product. For information on Technical Support plans and pricing, contact us at +1 952.912.3444 or visit us at www.digi.com/support.

Support portal login: www.digi.com/support/eservice

Contents

About the ConnectCore® 6UL

Features and functionality	6
ConnectCore 6UL module variants	8
Block diagrams	8
ConnectCore 6UL module	9
NXP i.MX6UL application processor	10
Power supply	11
Power supply architecture	11
System power-up sequence	14
Bootstrap	15
Boot from fuses	15
Internal boot	16
Serial downloader	17
Wireless interfaces	17
WLAN 802.11a/b/g/n/ac	17
Antenna ports	23
Bluetooth	23
RF control signals	23
Micro Controller Assist™	23
ConnectCore 6UL module lines related to the MCA	24
Reset control	25
IOs	26
Watchdog	28
Real-time clock	29
Tamper support	29
Power management	30
MCA firmware update	33
CryptoAuthentication device	33
Module pinout - general layout	33
External signals and pin multiplexing	35

Module specifications

Electrical specifications	116
With front-end LDO	116
Without front-end LDO	116
Power consumption	116
Power consumption use cases	117
Global power consumption	119
Power consumption: Wireless power consumption increase	120
Power consumption: Real wireless transmission	121
Power consumption: Wireless-UART bridge	122
Mechanical specifications	122
Dimensions	122

Host PCB footprint	124
Weight	125
Environmental specifications	125
Socket options	125

Assembly instructions

Moisture sensitivity and shelf life	128
Mounting	128
Solder paste print	128
Stencil	128
Coplanarity	128
SMT pick and place	129
SMT process parameter reference - for both castellation and LGA applications	129
Reflow profiles using a ten-zone oven, SAC 305 lead-free solder paste (Alpha OM-340)	129
Vapor Phase Profile Recommendation Using IBL 309 Batch Soldering Machine, SAC 305 Lead-Free Solder Paste (Alpha OM-340)	130
Vapor Phase IBL 309 batch soldering machine settings	132
Conformal coating	132

Certifications

External antenna	134
United States FCC	134
FCC notices	134
FCC-approved antennas	135
RF exposure	135
Europe	136
OEM labeling requirements	136
CE labeling requirements	136
Declarations of Conformity	136
Approved antennas	136
Canada (IC)	136
Labeling requirements	137
Transmitters with detachable antennas	137
RF exposure	137
Approved antennas	138
Japan	138
Approval Label (MIC Marking)	139

About the ConnectCore® 6UL

The ConnectCore 6UL module delivers a secure and extremely cost-effective connected System-on-Module platform that is slightly bigger than a postage stamp. Its innovative Digi SMTplus™ (patent-pending) surface mount form factor allows you to choose simplified design integration leveraging proven and easy-to-use edge-castellated SMT technology, or a versatile LGA option for ultimate design flexibility with access to virtually all interfaces.

Built on the NXP i.MX6UL application processor, the module is the intelligent communication engine for today's secure connected devices. It seamlessly integrates dual-Ethernet and pre-certified dual-band Wi-Fi (802.11a/b/g/n/ac) with Bluetooth 4.2 dual mode connectivity.



Features and functionality

The ConnectCore 6UL system-on-module is based on the i.MX6UL processor from NXP. This processor offers a number of interfaces, most of them multiplexed and not available simultaneously. The module has the following features:

- i.MX6UL single ARM Cortex-A7 core operating at speeds up to 528 MHz:
 - 32 Kb L1 instruction cache
 - 32 Kb L1 data cache
 - Up to 128 KB unified instruction/data L2 cache
 - NEON MPE (media processing engine) co-processor
- Up to 1 GB, 16-bit DDR3-800 memory
- Up to 2 GB, 8-bit SLC NAND flash memory
- NXP PF3000 power management IC (PMIC):
 - x 4 DC/DC buck converters
 - x 6 LDO regulators
 - x 1 DC/DC boost converter
 - OTP (one-time programmable) memory
 - Coin cell charger and always-ON RTC supply
- Graphical hardware accelerators:
 - PXP (PiXeL Processing Pipeline)
 - ASRC (asynchronous sample rate converter)
- Secure Element
- Security accelerators:

- ARM TrustZone
- CAAM (cryptographic acceleration and assurance module)
- SNVS (secure non-volatile storage)
- CSU (central security unit)
- A-HABv4 (advanced high-assurance boot)
- IEEE 802.11 a/b/g/n/ac WLAN interface
- Bluetooth version 4.2 dual-mode
- ARM Cortex-M0+ Micro Controller Assist™ (MCA) subsystem
- Debug interfaces:
 - System JTAG controller
 - Single Wired Debug (SWD) interface for the MCA
- Support of i.MX6UL interfaces:
 - 16-bit data/address bus
 - Display: 24-bit parallel bus
 - Camera: 24-bit parallel bus
 - KPP (key pad port)
 - TSC (touch screen controller)
 - x 2 MMC/SD/SDIO card ports
 - x 2 USB 2.0 OTG with integrated HS USB PHYs
 - x 2 10/100 Mbps Ethernet MAC
 - UART, SPI, I2C, PWM, ADC, CAN, I2S, and GPIOs
- Ultra-miniature SMT module (29 x 29 x 3.5 mm) based on 245 pads (245 LGA, 76 also available as castellated pads)

ConnectCore 6UL module variants

Smart part number	Part number	ConnectCore 6UL SOM variant	Description	CPU ¹	DDR3/Bus -width ²	WiFi/Bluetooth
CC-WMX-JN58-NE	50001939-01	0x02	ConnectCore for i.MX6UL-2, 528 MHz, Industrial Temp, 256 MB SLC NAND, 256 MB DDR3, Dual 10/100 Ethernet, 802.11a/b/g/n/ac, Bluetooth 4.1, ANT+	G2CVK05 - 40/+105°C 528 MHz	256MiB (1x2Gbit) / 16bit, -40/+95°C	
CC-MX-JN58-Z1	50001939-02	0x03	ConnectCore for i.MX6UL-2, 528 MHz, Industrial Temp, 256 MB SLC NAND, 256 MB DDR3, Dual 10/100 Ethernet	G2CVK05 - 40/+105°C 528 MHz	256MiB (1x2Gbit) / 16bit, -40/+95°C	

¹ CPU temperature is T_j (junction)
² DDR3 temperature is T_a (ambient)

Block diagrams

The figures below show block diagrams of the ConnectCore 6UL module and of the NXP i.MX6UL application processor.

ConnectCore 6UL module

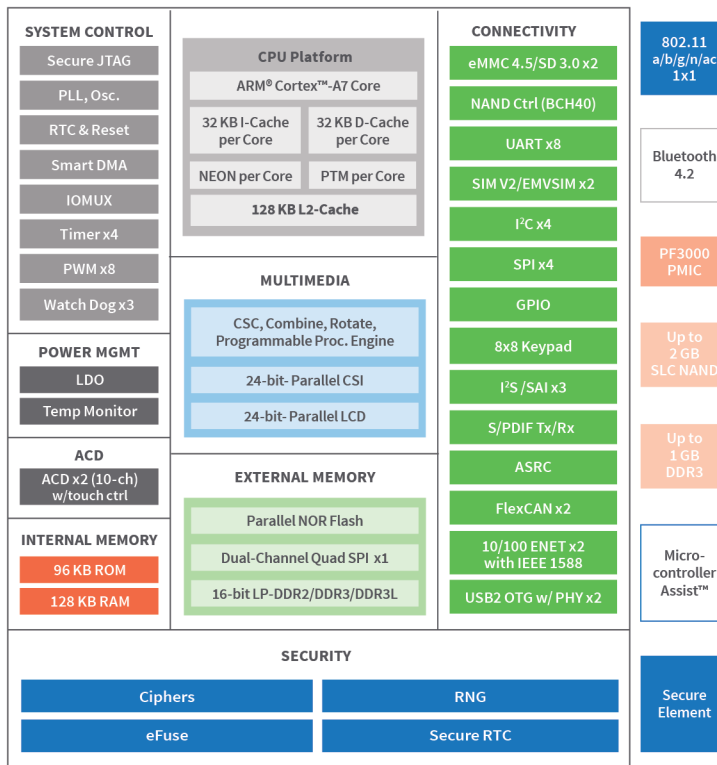

NXP i.MX6UL application processor

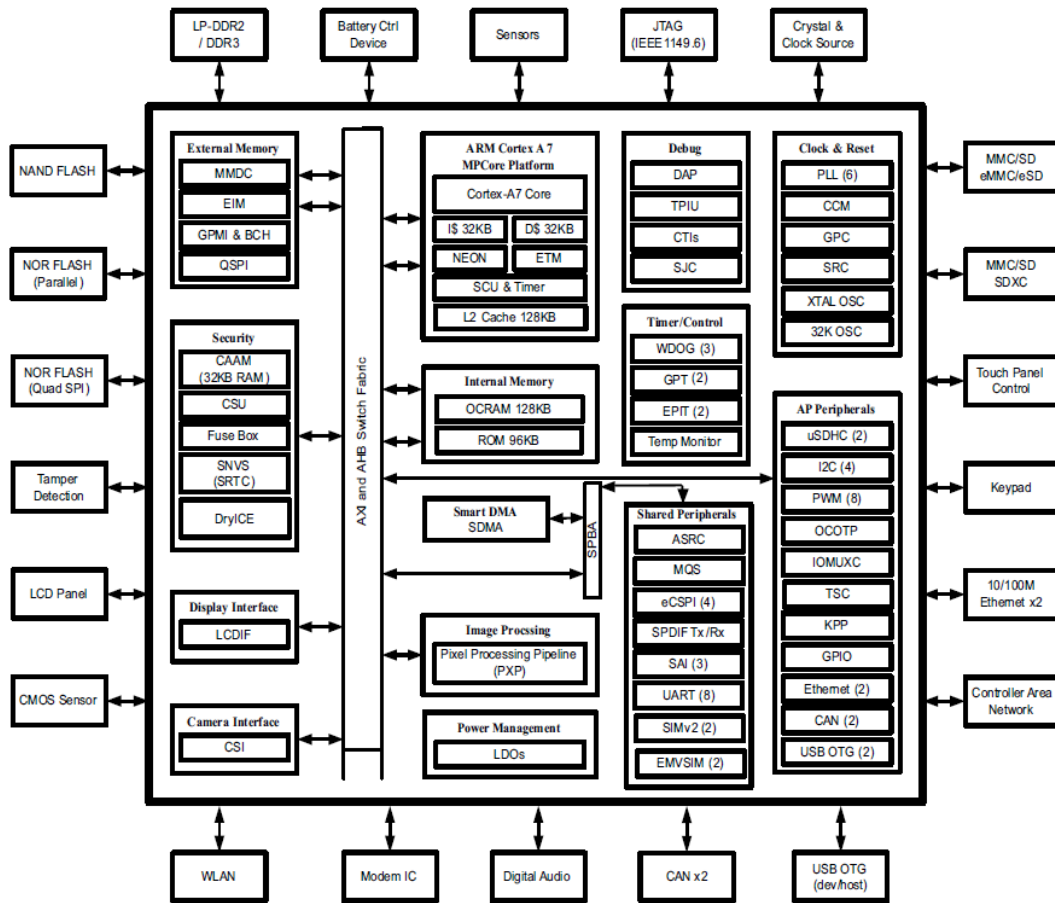

Power supply

Power supply architecture

The ConnectCore 6UL requires a primary power supply input. This supply is the main power domain to the on-module NXP PF3000 power management IC (PMIC), which generates all required supply voltages for the module as well as the external interfaces. The system can be powered from voltages up to 5.5V. See [Powering the system from a nominal 5V power supply \(4.5V to 5.5V\)](#) and [Powering the system for battery-powered applications \(3.7V - 4.5V\)](#) for recommended power schemes for the ConnectCore 6UL module.

The ConnectCore 6UL module has a dedicated pin for connecting a coin cell backup battery or super capacitor. You can enable a coin cell charger on the PMIC with Li-ion rechargeable batteries. This backup battery or super capacitor is mandatory if RTC time must persist after the module has been disconnected from main power. You must also follow the recommended diode configuration as shown in the diagrams below to make sure the module holds the system time.

If RTC time retention is not required, you can remove the circuitry from your design and connect the 3.3V voltage regulator directly to the VCC_MCA and MCA_VIN_DET pins.

Powering the system from a nominal 5V power supply (4.5V to 5.5V)

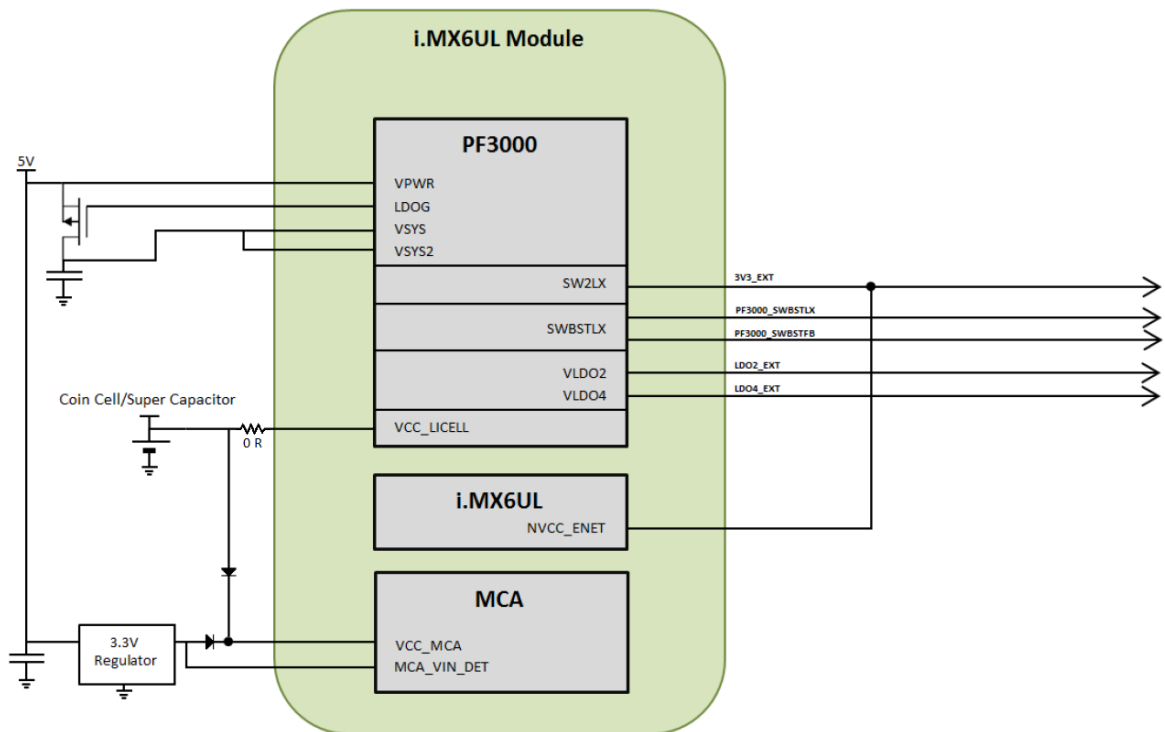

Powering the system for battery-powered applications (3.7V - 4.5V)

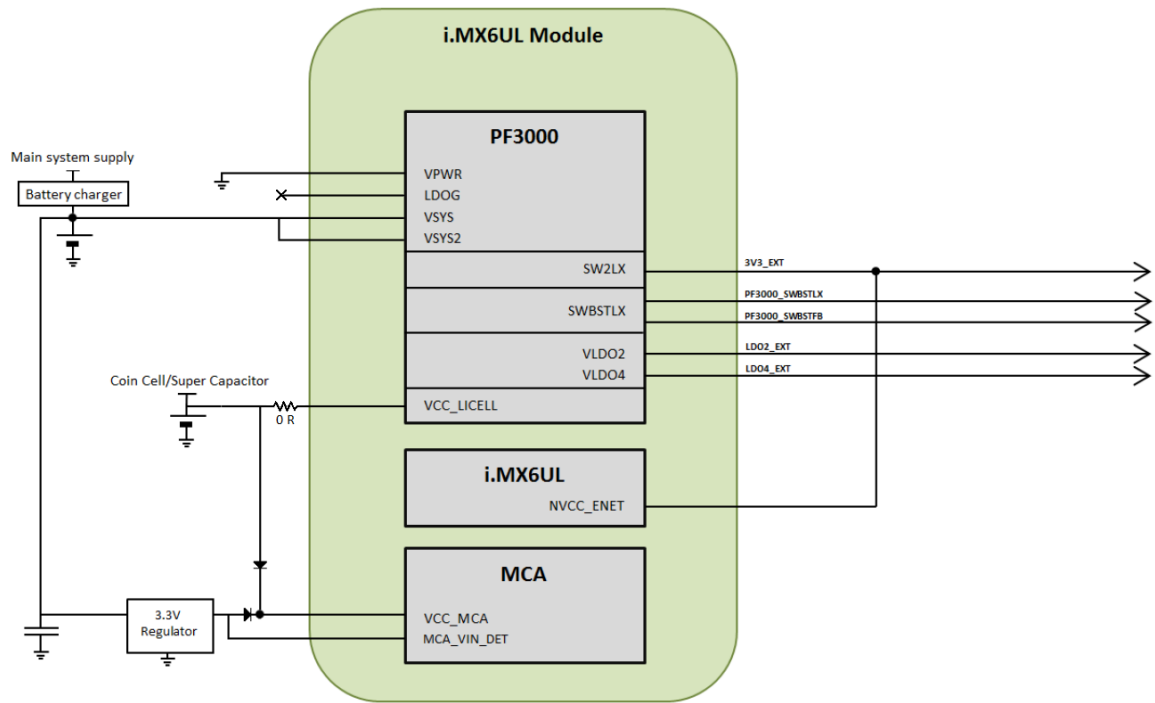

Note In the implementations shown above, the coin cell/supercapacitor is connected to VCC_LICELL pin of the ConnectCore 6UL module, allowing coin-cell charger applications. This VCC_LICELL connection feeds the VSNVS regulator of the PMIC, which supplies the SNVS power domain of the CPU. This power domain allows some functionality of the CPU in low power mode applications when the main power supply of the system is removed. However, this connection significantly increases the power consumption of the coin cell/supercapacitor in this low-power mode.

To optimize power management in coin cell applications:

Do not connect the coin cell/supercapacitor to the VCC_LICELL power domain (keep the connection to VCC_MCA). This removes coin-cell charger functionality but drastically reduces power consumption and extends the life of the power supply. However, this connection significantly increases the power consumption of the coin cell/supercapacitor in this low-power mode to around 350 uA.

The power architecture of the module is described in more detail below.

The PMIC generates the following power domains that are available on the module pads:

- Buck converters. Two buck regulators provide 3.3V:
 - SW1A: 3V3_INT, powers several interfaces inside the module
 - SW2: 3V3_EXT, free power line not used inside the module
- And another two buck regulators used for internal supply:
 - SW1B: VDD_ARM_SOC_IN
 - SW3: VCC_DDR3

Power domain	Regulator type	Output accuracy	Maximum current	Dropout voltage (MAX)	Turn on time (MAX)	Turn off time (MAX)	Quiescent current in OFF mode (TYP)
SW1A	DC/DC	+/-6.0 %	1.00 A	-	500 us	-	-
SW2	DC/DC	+/-6.0 %	1.25 A	-	500 us	-	-
SW1B	DC/DC	+/-6.0 %	1.75 A	-	500 us	-	-
SW3	DC/DC	+/-6.0 %	1.5 A	-	500 us	-	-

Note Maximum current includes both the module and the module carrier board consumption.
 SW1: parameters specified at TA=-40 °C to 85 °C, VIN=VSW1xIN=3.6V, VSW1x=1.2 V, ISW1x=100 mA.
 SW2: parameters specified at TA=-40 °C to 85 °C, VIN=VSW2IN=3.6V, VSW2=3.15 V, ISW2=100 mA.
 SW3: parameters specified at TA=-40 °C to 85 °C, VIN=VSW3IN=3.6V, VSW3=1.5 V, ISW3=100 mA.

- LDO regulators. Four PMIC regulators are available; the module uses LDO1: VDDA_ADC_3P3.

LDO	Regulator type	Output accuracy	Maximum current	Dropout voltage (MAX)	Turn on time (MAX)	Turn off time (MAX)	Quiescent current in OFF mode (TYP)
VLDO1	1.8-3.3V	+/-3.0 %	0.100 A	60 mV	500 us	10 ms	13 uA
VLDO2	0.8-1.55V	+/-3.0 %	0.250 A	60 mV	500 us	10 ms	13 uA
VLDO3	1.8-3.3V	+/-3.0 %	0.100 A	60 mV	500 us	10 ms	13 uA
VLDO4	1.8-3.3V	+/-3.0 %	0.350 A	60 mV	500 us	10 ms	13 uA

Note Maximum current includes both the module and the module carrier board consumption.
 VLDO1 parameters specified at TA=-40 °C to 85 °C, VIN=3.6V, VLDO1IN=3.6V, VLDO1=3.3V, ILDO1=10 mA.
 VLDO2 parameters specified at TA=-40 °C to 85 °C, VIN=3.6V, VLDO2IN=3.0V, VLDO2=1.55V, ILDO2=10 mA.
 VLDO3 parameters specified at TA=-40 °C to 85 °C, VIN=3.6V, VLDO34IN=3.6V, VLDO3=3.3V, ILDO3=10 mA.
 VLDO4 parameters specified at TA=-40 °C to 85 °C, VIN=3.6V, VLDO34IN=3.6V, VLDO4=3.3V, ILDO4=10 mA.

- Boost converter. The PMIC offers a boost regulator that is not used inside the module but that is available in the pinout of the LGA version for customizations.

Power domain	Regulator type	Output accuracy	Maximum current	Dropout voltage (MAX)	Turn on time (MAX)	Turn off time (MAX)	Quiescent current in OFF mode (TYP)
SWBST	DC/DC	-4.0% / +3%	0.6 A	-	2 ms	-	-

Note SWBST parameters specified at TA=-40 °C to 85 °C, VIN=VSWBSTIN=3.6V, VLSWBST=5.0V, ISWBST=100 mA.

VSYS and VSYS2 are the supply inputs to the regulators and buck converters of the PMIC. Both inputs are available on the module pads and can be connected to a single voltage input or to two different voltages on systems that require high efficiency on the power system:

- VSYS powers SW1A, SW2, LDO1 and LDO34 (shared input for LDO3 and LDO4).
- VSYS2 powers SW1B, SW3 and LDO2.

The power management IC located on the module is responsible for generating all required i.MX6UL processor supplies. Some of the I/O supplies are set on the module. See the following table:

Power domain	Connection
NVCC_NAND	3V3_INT
NVCC_GPIO	3V3_INT
NVCC_SD1	3V3_INT
NVCC_UART	3V3_INT
NVCC_CSI	3V3_INT
NVCC_LCD	3V3_INT

One I/O voltage must be set externally and is left unconnected on the ConnectCore 6UL module: NVCC_ENET. See the following table for operating range of NVCC_ENET:

Power domain	Min	Type	Max
NVCC_ENET	1.65 V	1.8/2.8/3.3 V	3.6 V

As shown in the table above, the supply has a wide operating range. In order to provide the most cost-effective and flexible solution for a given use case, the supplies listed in the table must be provided by the carrier board integrating the ConnectCore 6UL module. However, PMIC 3.3V and LDO power rails are dedicated power sources for supplying i.MX6UL power domains.

For more information related to the PMIC power-up strategy, refer to section 6.3.5 of the [NXP PF3000 datasheet](#).

System power-up sequence

When the power supply is connected to the ConnectCore 6UL module, the PMIC and the MCA are the first components to be powered up. VIN is the PMIC input power line, while VCC_MCA is the MCA input line. The MCA starts to run as soon as it is powered up, but the PMIC follows a fixed initialization process (see the [NXP PF3000 Datasheet](#) for a full description). In this initialization, the first regulator to automatically be powered on is the VDD_SNVS_3V3. Once this regulator is up, the PMIC can be switched on by controlling the PWRON pin (the on-off control line of the PMIC). This pin is controlled by the MCA. The MCA will turn on the PMIC after a user-programmable delay (by default 50 ms).

Once the PMIC is switched on, another fixed initialization process starts and the PMIC regulators are turned on following a defined sequence. Finally the CPU reset line (POR_B_CPU), which is also controlled by the MCA, is released.

The following time diagram shows the power-up sequence.

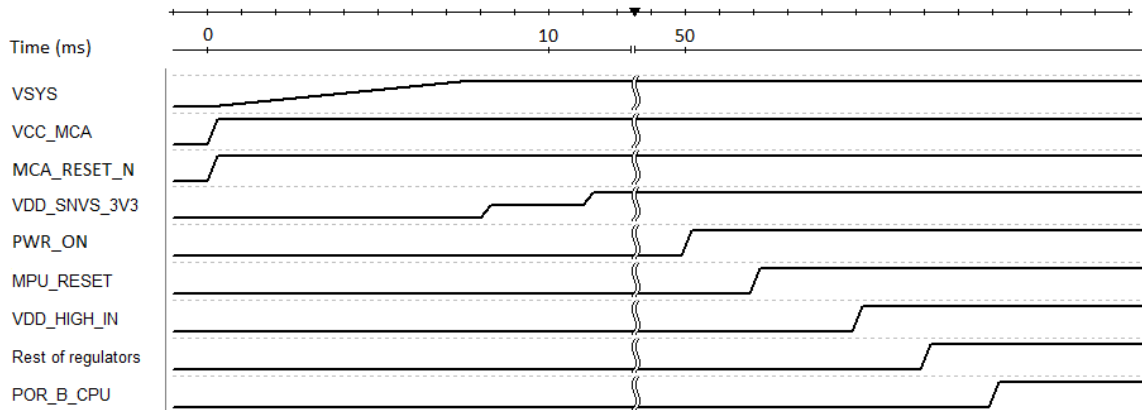

Bootstrap

The ConnectCore 6UL module can be configured to boot from different devices and interfaces as determined by the Boot ROM. The configuration of the booting process of the CPU is done through:

- BOOT_MODE register, which selects the boot mode of the processor.
- eFUSES and/or GPIOs, which determine the boot configuration.

Four boot modes are available on the i.MX6UL processor. Selection between them is done through BOOT_MODE[1:0] bits. The bits are externally configurable on two processor IOs, whose values are latched during boot-up:

BOOT_MODE [1:0]	Boot type
00	Boot from fuses
01	Serial downloader
10	Internal boot
11	Reserved

BOOT_MODE[0] and BOOT_MODE[1] are available on dedicated LGA pads on the module. However, on the castellated pads only BOOT_MODE[1] is available.

Note BOOT_MODE[0] is set to 0 internally on the module through a 100K pull-down resistor. This means that in applications using only the castellated pads of the module, the only boot modes available are Boot from fuses and Internal boot. However, once Uboot is running, you can select a different boot mode (like serial downloader).

Boot from fuses

Boot from fuses is the recommended boot mode for production purposes. When this boot mode is selected, you must configure several parameters in order to select and configure the boot device of

the system. These parameters are configured through fuses, which are burned in order to set their values. This means that the configuration is irreversible.

BOOT_CFG1 selects the boot device through BOOT_CFG1[7:4] bits:

BOOT_CFG1[7:4]	Boot device
0000	NOR/OneNAND (EIM)
0001	QSPI
0011	Serial ROM (SPI)
010x	SD/eSD/SDXC
011x	MMC/eMMC
1xxx	Raw NAND

There are many other registers that configure the different boot devices. For a complete description of the booting configuration, refer to the NXP i.MX 6UltraLite Applications Processor Reference Manual (Chapter 8: System Boot).

Internal boot

Internal boot is the recommended boot mode for development purposes. When this boot mode is selected, the selection and configuration of the booting process is done through the same registers used when booting from fuses. However, this time the values of some registers are overridden using multiple GPIOs, which are latched during power-up.

The following configuration is done internally in the ConnectCore 6UL module in order to enable booting from the NAND memory:

Bootstrap configuration	Corresponding GPIO	Default configuration
BOOT_CFG2[1]	LCD_DATA9	100K pull-down
BOOT_CFG2[2]	LCD_DATA10	100K pull-down
BOOT_CFG2[3]	LCD_DATA11	100K pull-up
BOOT_CFG2[4]	LCD_DATA12	100K pull-down
BOOT_CFG2[5]	LCD_DATA13	100K pull-up
BOOT_CFG2[6]	LCD_DATA14	100K pull-down
BOOT_CFG2[7]	LCD_DATA15	100K pull-down

You must also set up BOOT_CFG1[7:0] register when booting from the internal on-module NAND when Internal boot mode is selected. It must be configured externally (outside the module) as shown in the following table:

Bootstrap configuration	Corresponding GPIO	Configuration
BOOT_CFG1[0]	LCD_DATA0	0
BOOT_CFG1[1]	LCD_DATA1	0
BOOT_CFG1[2]	LCD_DATA2	0
BOOT_CFG1[3]	LCD_DATA3	0
BOOT_CFG1[4]	LCD_DATA4	1
BOOT_CFG1[5]	LCD_DATA5	0
BOOT_CFG1[6]	LCD_DATA6	0
BOOT_CFG1[7]	LCD_DATA7	1

Digi recommends you use 10K pull-up and pull-down resistors to configure each line.

The BOOT_CFG1 and BOOT_CFG2 register lines are not dedicated lines of the CPU. This means that the values of these lines are latched during the power-up, but have a different functionality once the system is up and running. In this case, these lines belong to the LCD interface. In order to protect the value of these registers while the system is booting, Digi recommends you use a protection circuitry as shown in sheet 3 of 7, "Boot selection," of the ConnectCore 6UL reference designs. See [ConnectCore 6UL design files](#).

Serial downloader

You can use the serial downloader boot mode for device recovery. The serial downloader allows you to download a program image to the chip through a USB or UART serial connection. When any of the standard boot modes is selected but the booting process doesn't succeed (for instance due to wrong booting device or corrupted images) the CPU automatically jumps to the serial downloader boot mode.

Wireless interfaces

The ConnectCore 6UL system-on-module combines a wireless local area network (WLAN) and Bluetooth (BT) dual solution to support IEEE802.11 a/b/g/n/ac WLAN standards and BT 4.2 enabling seamless integration of WLAN/BT and Low Energy technology. Digi also offers a non-wireless variant of the ConnectCore 6UL module.

The following sections include specifications for the wireless interfaces available on the ConnectCore 6UL module.

WLAN 802.11a/b/g/n/ac

The 2.4 GHz band on the ConnectCore 6UL module supports 20/40 MHz bandwidths, and the 5 GHz band supports 20/40/80 MHz bandwidths.

The following sections specify the performance of the WLAN IEEE 802.11a/b/g/n/ac interface on the ConnectCore 6UL module.

Modulation and data rates

The following tables list modulation values for ConnectCore 6UL module supports the following WLAN standards.

Mode	Modulation & coding	Rate
802.11b	DBPSK	1 Mbps
	DQPSK	2 Mbps
	CCK	5.5 Mbps
	CCK	11 Mbps
802.11ga	BPSK-1/2	6 Mbps
	BPSK-3/4	9 Mbps
	QPSK-1/2	12 Mbps
	QPSK-3/4	18 Mbps
	16QAM-1/2	24 Mbps
	16QAM-3/4	36 Mbps
	64QAM-2/3	48 Mbps
	64QAM-3/4	54 Mbps
802.11n	BPSK-1/2	MCS0
	QPSK-1/2	MCS1
	QPSK-3/4	MCS2
	16QAM-1/2	MCS3
	16QAM-3/4	MCS4
	64QAM-2/3	MCS5
	64QAM-3/4	MCS6
	64QAM-5/6	MCS7

Mode	Modulation & coding	Rate
802.11ac	BPSK-1/2	MCS0
	QPSK-1/2	MCS1
	QPSK-3/4	MCS2
	16QAM-1/2	MCS3
	16QAM-3/4	MCS4
	64QAM-2/3	MCS5
	64QAM-3/4	MCS6
	64QAM-5/6	MCS7
	256QAM-3/4	MCS8
	256QAM-5/6	MCS9

Note Rates MCS8 & MCS9 are only available in receive mode.

Data rate (Mbps) - Non Short Guard Interval (Non-SGI)

Data rate (Mbps)		802.11b		802.11ga		802.11n		802.11ac		
Modulation		DBPSK	CCK	BPSK-1/2	64QAM-3/4	BPSK-1/2	64QAM-5/6	BPSK-1/2	64QAM-5/6	256QAM-5/6
		1 Mbps	11 Mbps	6 Mbps	54 Mbps	MCS0	MCS7	MCS0	MCS7	MCS9
2.4 GHz	HT20	1	11	6	54	6.5	65	6.5	65	
	HT40					13.5	135	13.5	135	180
5 GHz	HT20			6	54	6.5	65	6.5	65	
	HT40					13.5	135	13.5	135	180
	HT80							29.3	292.5	390

Data rate (Mbps) - Short Guard Interval (SGI)

Mode	802.11b		802.11ga		802.11n		802.11ac		
Modulation	DBPSK	CCK	BPSK-1/2	64QAM-3/4	BPSK-1/2	64QAM-5/6	BPSK-1/2	64QAM-5/6	256QAM-5/6
	1 Mbps	11 Mbps	6 Mbps	54 Mbps	MCS0	MCS7	MCS0	MCS7	MCS9

Mode		802.11b		802.11ga		802.11n		802.11ac		
2.4 GHz	HT20	1	11	6	54	7.2	72.2	7.2	72.2	
	HT40					15	150	15	150	200
5 GHz	HT20			6	54	7.2	72.2	7.2	72.2	
	HT40					15	150	15	150	200
	HT80							32.5	325	433.3

RF channels

The ConnectCore 6UL module supports the following frequency bands.

RF band	Ch. BW	Ch. spacing	Channel number (Center freq. MHz)
2.4 GHz	20 MHz	5 MHz	1(2412), 2(2417), 3(2422), 4(2427), 5(2432), 6(2437), 7(2442), 8(2447), 9(2452), 10(2457), 11(2462), 12(2467), 13(2472), 14(2484)
	40 MHz	5 MHz	3(2422), 11(2462)
5 GHz	20 MHz	20 MHz	36(5180), 40(5200), 44(5220), 48(5240), 52(5260), 56(5280), 60(5300), 64(5320), 100(5500), 104(5520), 108(5540), 112(5560), 116(5580), 120(5600), 124(5620), 128(5640), 132(5660), 136(5680), 140(5700), 144(5720), 149(5745), 153(5765), 157(5785), 161(5805), 165(5825)
	40 MHz	40 MHz	38(5190), 46(5230), 54(5270), 62(5310), 102(5510), 110(5550), 118(5590), 126(5630), 134(5670), 142(5710), 151(5755), 159(5795)
	80 MHz	80 MHz	42(5210), 58(5290), 106(5530), 122(5610), 138(5690), 155(5775)

Note Dependent upon regulatory bodies.

2.4 GHz

2.4 GHz band channel #	Center frequency (MHz)	EUROPE (ETSI)	NORTH AMERICA (FCC)	JAPAN
1	2412	✓	✓	✓
2	2417	✓	✓	✓
3	2422	✓	✓	✓
4	2427	✓	✓	✓
5	2432	✓	✓	✓
6	2437	✓	✓	✓

2.4 GHz band channel #	Center frequency (MHz)	EUROPE (ETSI)	NORTH AMERICA (FCC)	JAPAN
7	2442	✓	✓	✓
8	2447	✓	✓	✓
9	2452	✓	✓	✓
10	2457	✓	✓	✓
11	2462	✓	✓	✓
12	2467	✓	No	✓
13	2472	✓	No	✓
14	2484	No	No	802.11b only

5 GHz

5 GHz band channel #	Center frequency (MHz)	EUROPE (ETSI)	NORTH AMERICA (FCC)	JAPAN
36	5180	Indoors	✓	✓
40	5200	Indoors	✓	✓
44	5220	Indoors	✓	✓
48	5240	Indoors	✓	✓
52	5260	Indoors / DFS / TPC	DFS	DFS / TPC
56	5280	Indoors / DFS / TPC	DFS	DFS / TPC
60	5300	Indoors / DFS / TPC	DFS	DFS / TPC
64	5320	Indoors / DFS / TPC	DFS	DFS / TPC
100	5500	DFS / TPC	DFS	DFS / TPC
104	5520	DFS / TPC	DFS	DFS / TPC
108	5540	DFS / TPC	DFS	DFS / TPC
112	5560	DFS / TPC	DFS	DFS / TPC
116	5580	DFS / TPC	DFS	DFS / TPC
120	5600	DFS / TPC	No Access	DFS / TPC
124	5620	DFS / TPC	No Access	DFS / TPC
128	5640	DFS / TPC	No Access	DFS / TPC
132	5660	DFS / TPC	DFS	DFS / TPC
136	5680	DFS / TPC	DFS	DFS / TPC

5 GHz band channel #	Center frequency (MHz)	EUROPE (ETSI)	NORTH AMERICA (FCC)	JAPAN
140	5700	DFS / TPC	DFS	DFS / TPC
149	5745	SRD	✓	No Access
153	5765	SRD	✓	No Access
157	5785	SRD	✓	No Access
161	5805	SRD	✓	No Access
165	5825	SRD	✓	No Access

Note

DFS = Dynamic Frequency Selection

TPC = Transmit Power Control

SRD = Short Range Devices 25 mW max power

Transmit power

The following table lists nominal transmit power values for the ConnectCore 6UL module.

RF band	Channel BW	Standard	Output power (dBm)
2.4 GHz	20 MHz	802.11b	18 (1Mbps) - 18 (11Mbps)
	20 MHz	802.11g	18 (6Mbps) - 14 (54Mbps)
	20 MHz	802.11n/ac	17 (MCS0) - 13 (MCS7)
	40 MHz	802.11n/ac	15 (MCS0) - 13 (MCS7)
5 GHz	20 MHz	802.11a	13 (6Mbps) - 11 (54Mbps)
	20 MHz	802.11n/ac	15 (MCS0) - 8 (MCS7)
	40 MHz	802.11n/ac	12 (MCS0) - 7 (MCS7)
	80 MHz	802.11ac	9 (MCS0) - 4 (MCS7)

Note Nominal powers are subject to regulatory domain regulations.

Note Due to manufacturing tolerance these nominal output powers may be reduced up to 3 dB.

Receiver sensitivity

The following table lists typical receive sensitivity values for the ConnectCore 6UL module.

Mode		802.11b		802.11ga		802.11n		802.11ac		
Modulation		DBPSK	CCK	BPSK-1/2	64QAM-3/4	BPSK-1/2	64QAM-5/6	BPSK-1/2	64QAM-5/6	256QAM-5/6
		1 Mbps	11 Mbps	6 Mbps	54 Mbps	MCS0	MCS7	MCS0	MCS7	MCS9
2.4 GHz	HT20	-90	-84	-85	-69	-84	-65	-82	-64	
	HT40					-79	-61	-79	-61	-54
5 GHz	HT20			-86	-72	-86	-67	-82	-64	
	HT40					-79	-61	-79	-61	-54
	HT80							-76	-58	-51

Note Specification is subject to change.

Antenna ports

The ConnectCore 6UL module has two antenna ports: one on the module via a dedicated U.FL connector, and another on the LGA pads. Both antenna ports support WLAN and Bluetooth functionality. You can use the control signal RF1_INT/nEXT to select between the on-module antenna port (U.FL connector) and the external antenna port (LGA pad). This control signal has a 10K pull-up populated on the module, which means that the on-module antenna port (U.FL connector) is active by default. Pulling RF1_INT/nEXT low activates the external antenna port and disables the on-module antenna port.

Bluetooth

The ConnectCore 6UL module supports both Bluetooth and Bluetooth Low Energy protocols:

- Bluetooth 4.2 (BT4.2); backwards compatible with BT 1.X, 2.X + Enhanced Data Rate, BT 3.X, BT 4.0 and BT 4.1 Bluetooth class 1 and class 2 power-level transmissions
- Integrated WLAN-BT coexistence

RF control signals

The following signals are **not** supported by the current firmware of the WLAN/BT transceiver:

- WLAN_RF_KILL# (pad B17)
- BT_RF_KILL# (pad B18)
- WLAN_LED (pad B19)
- BT_LED (pad B20)

Micro Controller Assist™

The Micro Controller Assist, or MCA, is a small microcontroller that is deeply integrated into the design of the ConnectCore 6UL module. It assists the i.MX6UL processor with advanced operations related to power management, security, and system reliability. The functionality provided by the MCA includes:

- Advanced power management such as power key button, wake up sources, and PMIC control in low power.
- Peripheral extensions such as RTC, watchdog, and tamper pins.

The MCA and the i.MX6UL are connected through an I2C interface and an interrupt line. The microcontroller provides up to eight general purpose IOs that can be configured with different modes to provide functionality such as digital input/output or ADC.

The i.MX6UL can update the MCA firmware over the I2C bus. See the [MCA software documentation](#) for additional information about this process.

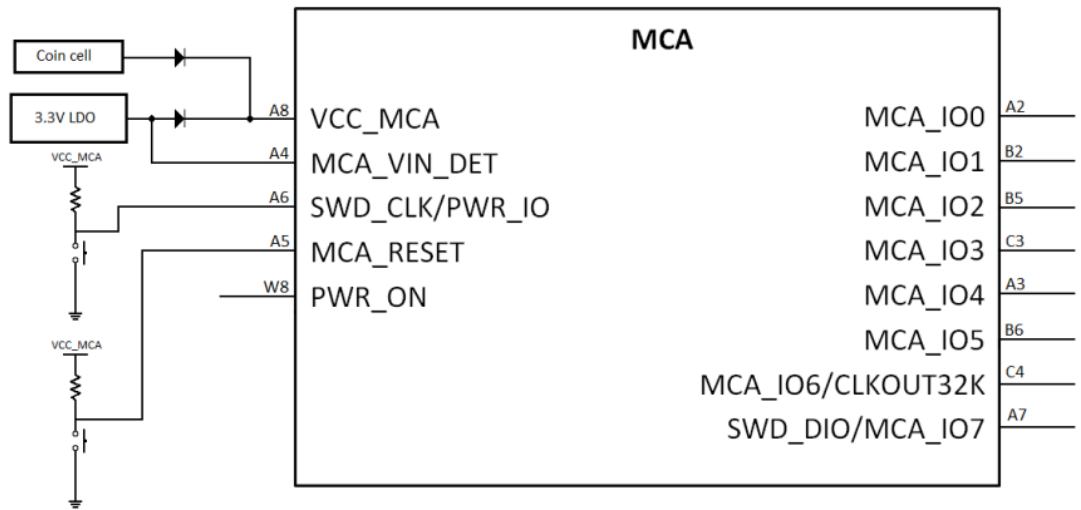

ConnectCore 6UL module lines related to the MCA

Pin number	Pin name	Pin direction	Type	Definition
A2	MCA_IO0	Bi-directional	Digital and analog	General purpose Input/Output.
A3	MCA_IO4	Bi-directional	Digital and analog	General purpose Input/Output.
A4	MCA_VIN_DET	Input	Analog	Input voltage detection line. Connect to VCC_MCA.
A5	MCA_RESET	Input	Digital	Reset input line, active low.
A6	SWD_CLK/PWR_IO	Input	Digital	Power on/off input line, active low. SWD interface clock line.

Pin number	Pin name	Pin direction	Type	Definition
A7	SWD_DIO/MCA_IO7	Bi-directional	Digital	General purpose Input/Output. SWD interface data line.
A8	VCC_MCA	Input	Analog	Input power supply of the MCA.
B2	MCA_IO1	Bi-directional	Digital and analog	General purpose Input/Output.
B5	MCA_IO2	Bi-directional	Digital	General purpose Input/Output.
B6	MCA_IO5	Bi-directional	Digital and analog	General purpose Input/Output.
C3	MCA_IO3	Bi-directional	Digital and analog	General purpose Input/Output.
C4	MCA_IO6/CLKOUT32K	Bi-directional	Digital	General purpose Input/Output. 32KHz clock output.
W8	PWR_ON	Output	Digital	Output power on/off line. Set to high level* during power off.

* low level

Reset control

Asserting and de-asserting the MCA_RESET line wakes the ConnectCore 6UL module from any power mode (suspend/power off). Then, the microcontroller executes the programmed firmware.

The MCA, in cooperation with the PMIC, controls the reset line of the i.MX6UL processor (POR_B). The MCA_RESET pin is the main reset input of the ConnectCore 6UL module. This pin is a pseudo open-drain with an internal pull up. Asserting the MCA_RESET line low sets the MCA into reset state, and it remains in this state until the line is de-asserted.

During system initialization, the MCA performs the following actions:

- Asserts the PWR_ON line low for a configurable number of milliseconds (0-255 ms with a default value of 50ms). This powers the PMIC off, switching off all regulated outputs of the PMIC. You can disable this power cycle by setting the timer to 0.
- Asserts the PWR_ON line high to power the system on (assuming it was asserted low before).
- Keeps POR_B asserted low for a configurable number of milliseconds.
- Asserts the POR_B line high to start the execution of the firmware on the i.MX6UL processor.

The following time diagram represents the reset sequence. You can configure the reset timing. Default values are as follows:

- tr1: 50 ms
- tr2: 2 ms

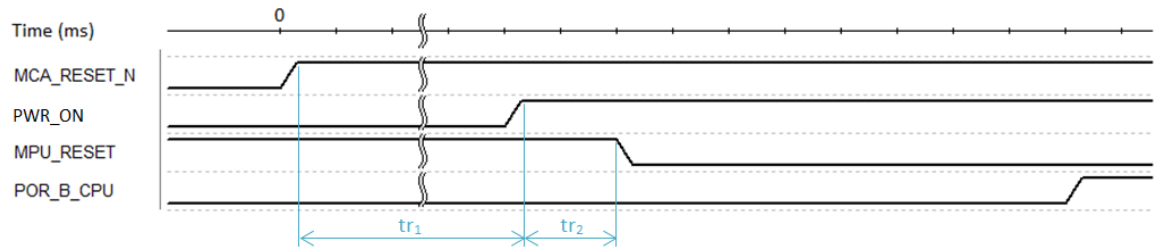

See [System power-up sequence](#) for more information about the power-up sequence of the ConnectCore 6UL.

Note The POR_B line is also connected to the PMIC. The PMIC won't release this line until it is switched on and the entire starting sequence is finished (a few ms after the latest regulator is turned on). This means that even if the MCA releases the reset line before the PMIC is ready, the CPU won't go out of reset. This occurs on the ConnectCore 6UL module: the MCA releases the CPU reset line by putting the MPU_RESET line high but there's a delay since this GPIO goes high until the POR_B_CPU line goes high. The delay occurs because the PMIC is still not completely initialized.

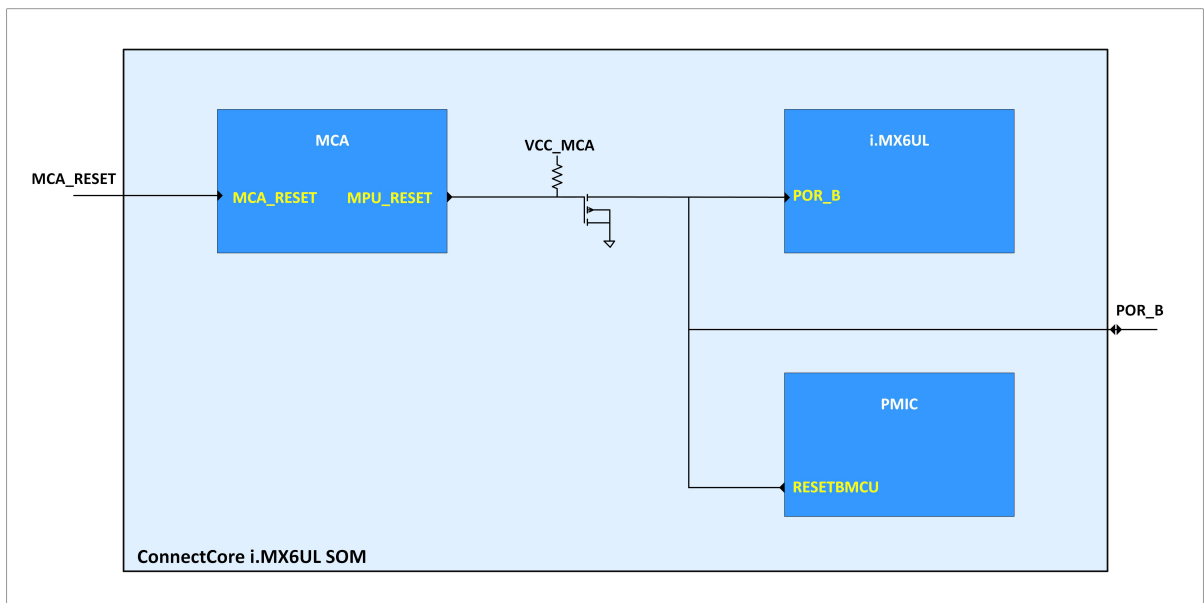

See the [MCA software documentation](#) for additional information on the configuration of the MCA.

IOs

The ConnectCore 6UL MCA provides up to eight configurable IOs.

Since the general purpose IOs do not incorporate internal pull-ups or pull-downs, you may have to add the components to the exterior of the module carrier board.

The following table lists all available MCA IOs with capabilities and module pad:

MCA IO	PAD LGA/CS*	Digital I/O	IRQ capable	ADC	32KHz clock	1.2 Vref
MCA_IO0	A2/76	✓	✓	✓		
MCA_IO1	B2	✓	✓	✓		
MCA_IO2/EXT_VREF	B5	✓	✓			✓
MCA_IO3	C3	✓		✓		
MCA_IO4	A3/75	✓		✓		
MCA_IO5	B6	✓	✓	✓		
MCA_IO6/CLKOUT32K	C4	✓			✓	
SWD_DIO/MCA_IO7	A7/71	✓				

* CS = castellated pads

Digital IOs

All MCA IOs can be configured as digital inputs/outputs, which are powered from the MCA_VCC power rail.

The digital outputs preserve the output value set in all operating modes, except in power off and coin cell modes where the IOs are reconfigured to high impedance state to preserve power.

Note Since the general purpose IOs do not incorporate internal pull-ups or pull-downs, you may need to add the components to the exterior of the module carrier board.

MCA IRQs

You can configure a subset of the MCA IOs as interrupt inputs, using the MCA software to configure the active edge of the interrupt (rising, falling, or both). When one or more MCA IRQs are activated, the MCA interrupts the main processor through the corresponding IRQ line, signaling the active IRQs in the IRQ status registers. The IRQ inputs can wake the system from any low power mode (suspend or power off).

See the MCA software documentation for additional information about how to configure and access the MCA IRQ lines.

Analog to Digital Converter

You can configure up to five MCA IOs as Analog to Digital channels in addition to the ones provided by the i.MX6UL CPU. The index of the MCA ADC channels corresponds to the index of the MCA IO. This means that the ADC channel 0 corresponds to the MCA_IO0, the ADC channel 1 to the MCA_IO1, and so on.

The result of the ADC conversion for a given input voltage is inversely proportional to the reference voltage of the ADC. For the MCA ADCs, the reference voltage corresponds to the MCA_VCC voltage. (Note that the i.MX6UL ADCs have a different reference voltage.) The MCA ADC provides 12-bit of resolution with right-justified, unsigned format output. These ADCs are suitable for low-frequency sampling (under 10 Hz). For higher frequency sampling, Digi recommends the CPU ADC channels.

See the [MCA software documentation](#) for additional information about how to configure and access the MCA ADCs.

External voltage reference

The MCA_IO2/EXT_VREF pin provides an accurate voltage reference of 1.2V that can be used to provide a reference voltage for sensors and/or analog devices (such as comparators or DACs).

When this pin is used as external reference voltage or as the internal reference of the MCA analog-to-digital converter, an external capacitor of 100nF must be connected between the pin and ground and as close as possible to the module pad.

The default configuration of the MCA_IO2/EXT_VREF pin is as IO. You must use software to configure the pin for external voltage reference. See the software documentation for additional information about how to control the function of this pin.

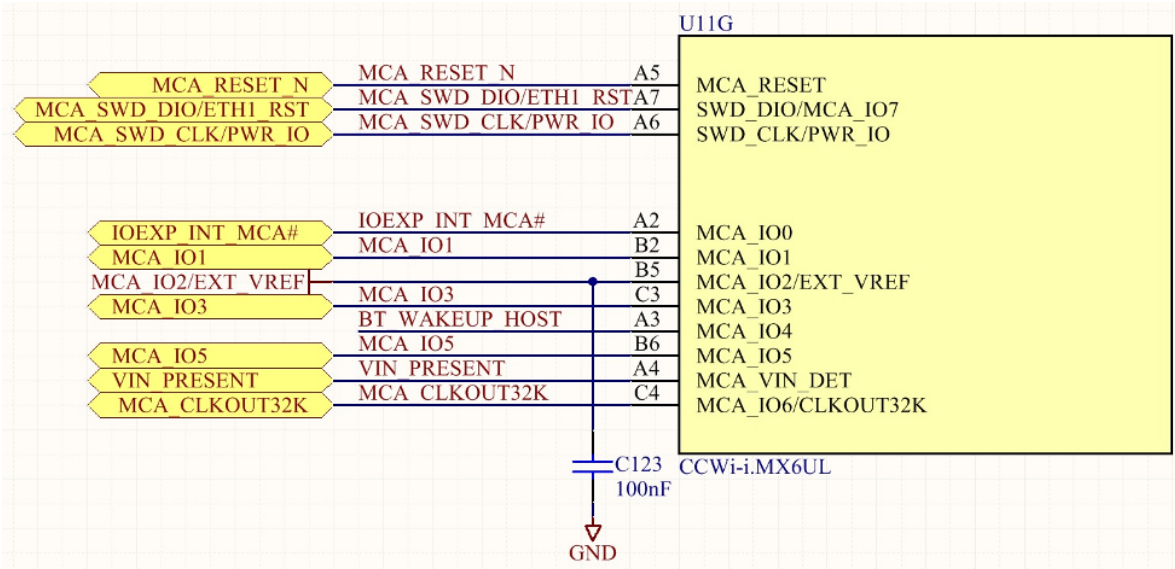

Note that the voltage reference continues normal operation in low power modes (suspend and power off). Therefore, if the voltage reference is enabled during normal operation but is not required for low power operation, Digi recommends using the software to disable it before entering low power in order to minimize the power consumption, and re-enable it when resuming normal operation.

External 32KHz clock output

The MCA_IO6/CLKOUT32K pin is a 32.768 Hz square wave output that can be used as clock input by peripherals requiring a low-frequency, high-accuracy clock.

Note The default configuration of the MCA_IO6/CLKOUT32K pin is as IO. You must use software to configure the pin as 32KHz clock output. See the [MCA software documentation](#) for additional information about how to control the function of this pin.

Note that the 32KHz clock output continues normal operation in low power modes (suspend and power off). Therefore, if the 32KHz clock output is enabled during normal operation but is not required for low power operation, Digi recommends using the software to disable it before entering low power in order to minimize power consumption, and re-enable it when resuming normal operation.

Watchdog

The MCA implements a watchdog timer in its firmware. The MCA watchdog resets the system, or only the i.MX6UL CPU, if the software running on the main processor fails to execute properly and does not reset the watchdog timer on time.

The main features of the MCA watchdog include:

- Configurable timeout between 1 and 255 seconds.
- Configurable to generate interrupt or system reset.
- Configurable to generate full-system reset (including the MCA itself) or CPU-only reset. Full-system reset can include a PMIC off/on, depending on the device configuration.

See the [MCA software documentation](#) for additional information about how to configure and access the watchdog timer.

Real-time clock

The MCA implements a Real-Time Clock (RTC) in its firmware. The i.MX6UL CPU internal RTCs are disabled by default because the MCA RTC is preferred due to its superior power consumption efficiency. To preserve the date during power-off, you must connect a coin cell battery following the design notes provided in the Power Supply Architecture section. You must also connect the MCA line VIN_PRESENT following the design guidelines in [Power supply architecture](#) in order to detect power loss and automatically switch to RTC mode.

The main features of the MCA RTC include:

- Date/time registers to keep the system time (backed up by the coin cell battery).
- Programmable alarm to generate and interrupt. This alarm can be used to wake the system from low power modes (suspend and power off).

See the [MCA software documentation](#) for additional information about how to configure and access the watchdog timer.

Tamper support

The tamper interface provides a mechanism to detect any unauthorized attempt to access the system, such as the opening of the enclosure. The tamper support included in the ConnectCore 6UL is implemented in the MCA with the following capabilities:

- Configure up to two tamper interfaces, each with an optional digital output.
- Rely on tamper detection event in power-off and coin cell (battery backup) modes.
- Register tamper event(s) in the non-volatile memory of the MCA.
- Alert the host CPU when a tamper event occurs.
- Respond to a tamper attack with actions such as erasing a critical data partition of the flash.

Tamper pins

The ConnectCore 6UL module supports up to two tamper interfaces (tamper0 and tamper1). Each interface has an associated IO (tamper pin) used to detect the tamper event (through a voltage transition on the IO) and, optionally, an output IO (tamper output) that can be used to enable or disable peripherals, for instance to cut the power of a peripheral. The IOs of each tamper interface can be configured independently and have the following configuration options:

- The MCA IO used for tamper detection, from the available MCA IOs that are IRQ-capable.
- The active level (tampering) of the tamper input.
- The MCA IO used as tamper output, when enabled, that is activated when a tamper condition has not been acknowledged.
- The logic level that is set in the tamper output when a tamper event occurs.

The MCA IO table provides information about the capabilities of the MCA IO pins so you can easily identify suitable IOs to be used as tamper inputs. Any MCA IO pin can be configured as tamper output.

Tamper pin configuration

To learn more about tamper pin configuration, see [Tamper detection interface](#) in the software documentation.

Power management

The MCA plays a key role in the power management activities of the ConnectCore 6UL module. In cooperation with the i.MX6UL processor, the MCA controls the power states of the PMIC, provides multiple wake up sources to transition between power modes. It also allocates dedicated signals to capture power events and indicate the system power state, allowing you to control external power sources and indicators.

Power modes

The module provides four different power operating modes: ON/RUN, OFF, SUSPEND, and COIN-CELL. The following figure shows the state diagram and the events to switch between states.

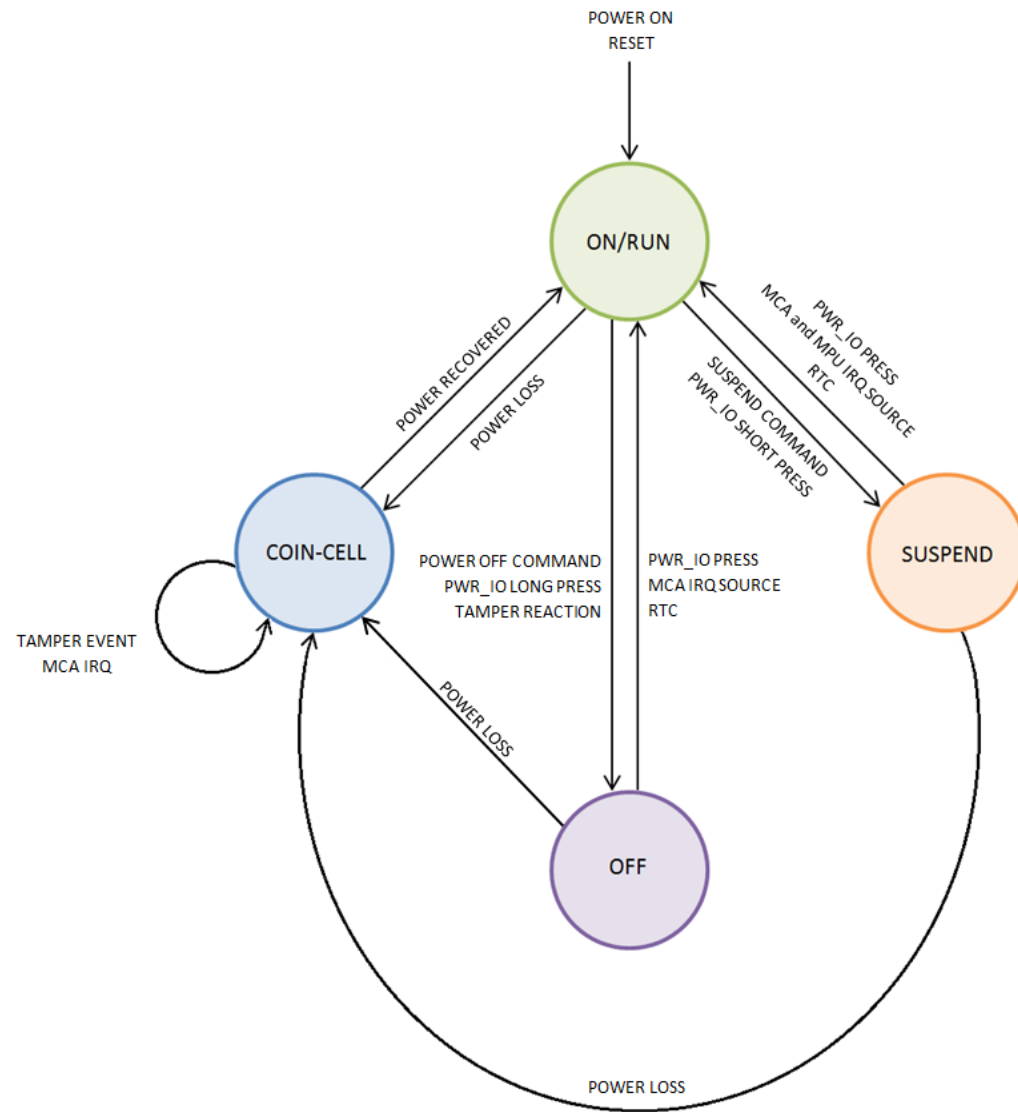

ON/RUN mode

The module enters the ON state after a power-on or system-reset event. In this mode, the PMIC is running at full power so all voltage regulators are generating the nominal voltage for this mode. The cpu reset line is de-asserted and the processor is running at normal speed, performing DVFS if the system was configured to do so. In this state, the PWR_ON line is asserted low, indicating that the module is ON.

Note that the specific state of the regulators (on/off) and the voltage in this mode are controlled by the firmware running on the i.MX6UL processor. The PMIC starts with the default settings configured on the OTP area, but once the software takes control it applies the specific configuration implemented in the firmware.

SUSPEND mode

The suspend mode (also known as suspend-to-ram mode) is the low-power mode that allows the module to preserve ram content. When the module enters SUSPEND, the following actions take place:

- The processor goes into low power, disabling as much functionality as possible and keeping active only the peripherals configured to wake the system from SUSPEND.
- The DDR memory is set to self-refresh mode to preserve its contents while reducing power consumption.
- The PMIC goes into standby mode, configuring the regulators in the configured mode (on, off, with a different voltage compared to ON state).
- The MCA goes into sleep mode, keeping active the peripherals that always run in low power modes (like the RTC) and those configured to wake up the system (such as IRQs and power IO).

OFF mode

The module enters OFF mode after a power-off event. In this mode:

- The PMIC is set to the OFF state and all the voltage regulators, except VSNVS, are switched off.
- The PWR_ON line is asserted low, indicating that the module is in OFF state.
- The MCA goes into sleep mode, keeping active the peripherals that always run in low-power modes (like the RTC) and those configured to wake up the system (such as IRQs and power IO).

COIN-CELL mode

In COIN-CELL mode, the module only powers the MCA from the coin-cell battery, leaving the rest of the module power inputs switched off. In this mode, the MCA remains in sleep mode, updating the RTC and monitoring the following events:

- Tamper events that would be registered in the NVRAM memory of the MCA and would assert the Tamper output if enabled.
- Power in MCA_VIN_DET, which indicates that there is sufficient voltage to generate a power-on event.

Power IO signal/Power button

The MCA provides a signal (PWR_IO) to detect external events that trigger a transition between the different power modes described in [Power modes](#). The pin has wake-up interrupt/event capabilities, it is active low, and it does not provide an internal pull-up. (The pull-up resistor must be added externally if required.) This signal is ideal for connecting a power button or the output of a peripheral that controls the power state of the module and its transitions. The firmware provides a configurable debounce filter to improve noise immunity and filter rebounds on push buttons. When the PWR_IO signal is asserted low, one of the following events occurs:

- If the duration of the assertion is short (time configurable by the user) the system will trigger an interrupt that, commonly, indicates the host processor that the system should enter suspend state.
- If the low-pulse duration is long enough (again, time configurable by the user) the system will trigger the power off interrupt, to indicate the host processor to start a transition to OFF state.
- If the system does not enter OFF state before a configurable guard timer expires, the MCA will automatically set the OFF state.

Digi recommends you use an external pull-up resistor of 100K to VCC_MCA in this SWD_CLK/PWR_IO line.

MCA_VIN_DET signal

The on-module MCA is powered from a dedicated external power rail, VCC_MCA. As recommended in the reference designs (see [Power supply architecture](#)), this power supply is provided by an external 3.3V regulator. If the system requires system time to be kept when there is no power, you must use a coin-cell battery to power the MCA while it keeps the RTC up to date in low-power mode. The MCA uses the MCA_VIN_DET input to monitor the input voltage and automatically switch to RTC mode to keep the system time and save power. Follow the design guidelines provided in [Power supply architecture](#) to apply the proper voltage to MCA_VIN_DET when there is a coin-cell battery in the system and when there is not.

MCA firmware update

The i.MX6UL processor can update the firmware of the MCA. See the [MCA software documentation](#) for additional information about the MCA firmware update process.

CryptoAuthentication device

The ConnectCore 6UL module includes an Atmel CryptoAuthentication Device. This is a highly secure cryptographic co-processor with secure hardware-based key storage. It includes the following features:

- Performs high-speed public key (PKI) algorithms (ECDSA and ECDH).
- NIST standard P256 elliptic curve support.
- SHA-256 hash algorithm with HMAC option.
- 256-bit key length.
- Storage for up to 16 keys.
- Two high-endurance monotonic counters.
- Guaranteed unique 72-bit serial number.
- Internal High-quality FIPS Random Number Generator (RNG).
- 10 Kb EEPROM memory.

See the [software documentation](#) for information about supported cryptoauthentication features.

Module pinout - general layout

The ConnectCore 6UL module has a mixed pad structure. The module provides 245 LGA pins, 76 of them connected to the peripheral castellated pads. The general layout can be found on the following diagram:

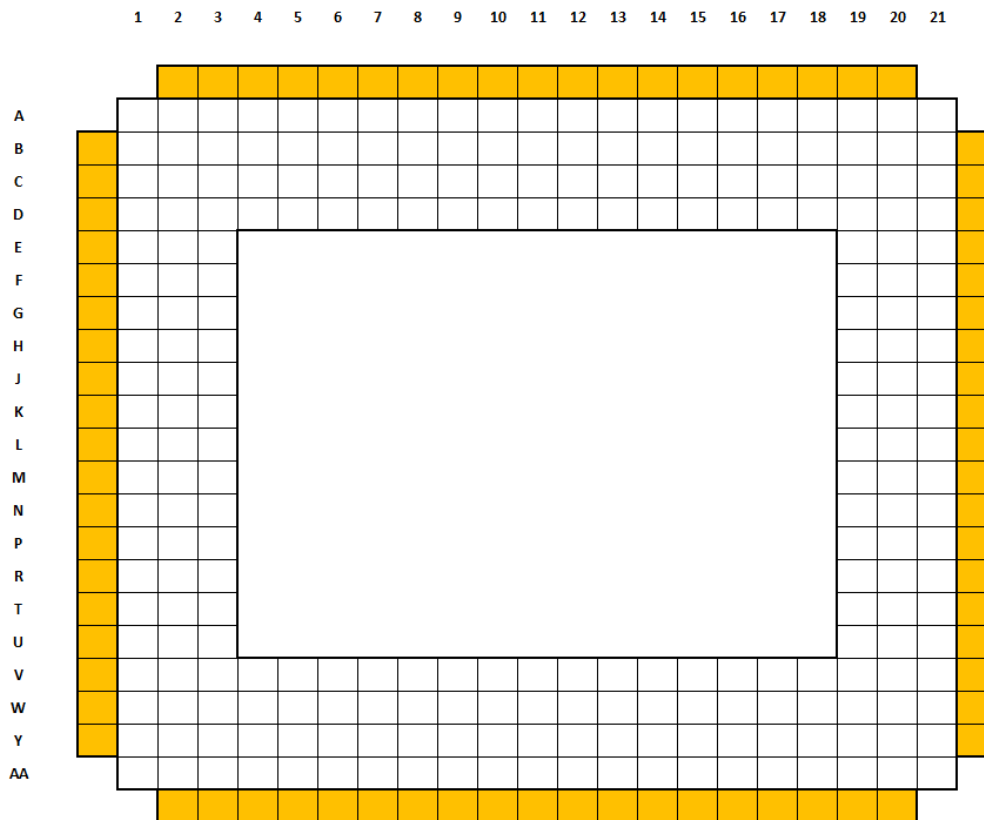

- White cells: LGA pads
- Orange cells: castellated pads

Note Pad A1 is unconnected. This pad is meant for module-orientation purposes; its shape is square, whereas all other pads are circular. Pad A1 should not be soldered down to a corresponding pad on the carrier board.

External signals and pin multiplexing

The following tables provide the pinout information of the ConnectCore 6UL module. For additional information related to the signals listed in the table, refer to the NXP i.MX6UL technical documentation.

Castellated pad signals and multiplexing

Castellated pad	ConnectCore 6UL pad	ConnectCore 6UL signal name	i.MX6UL pad name	Multiplexing	Power group	Comments
1 / B1	CPAD1	VCC_LICELL	-		VCC_LICELL	Coin cell supply
2 / C1	CPAD2	VSYS	-		VSYS	Power line
3 / D1	CPAD3	VPWR	-		VPWR	Power line
4 / E1	CPAD4	LDOG	-		LDOG	PMIC output (Front-end LDO)
5 / F1	CPAD5	GND	-		-	
6 / G1	CPAD6	VSYS	-		VSYS	Power line
7 / H1	CPAD7	VSYS2	-		VSYS2	Power line
8 / J1	CPAD8	GND	-		-	
9 / K1	CPAD9	3V3_EXT	-		3V3_EXT	Power line (PMIC SW2 output)

Castellated pad	ConnectCore 6UL pad	ConnectCore 6UL signal name	i.MX6UL pad name	Multiplexing	Power group	Comments
10 / L1	CPAD10	LCD_DATA8	LCD_DATA08	ALT0: LCDIF_DATA08 ALT1: SPDIF_IN ALT2: ALT3: CSI_DATA16 ALT4: EIM_DATA0 ALT5: GPIO3_IO13 ALT6: SRC_BT_CFG08 ALT7: ALT8: FLEXCAN1_TX	VCC_LCD	
11 / M1	CPAD11	LCD_DATA9	LCD_DATA09	ALT0: LCDIF_DATA09 ALT1: SAI3_MCLK ALT2: ALT3: CSI_DATA17 ALT4: EIM_DATA1 ALT5: GPIO3_IO14 ALT6: SRC_BT_CFG09 ALT7: ALT8: FLEXCAN1_RX	VCC_LCD	
12 / N1	CPAD12	VCC_ENET			VCC_ENET	Power line (expected 3.3 V)
13 / P1	CPAD13	POR_B			VDDIO	Input reset line of the module (active low)

Castellated pad	ConnectCore 6UL pad	ConnectCore 6UL signal name	i.MX6UL pad name	Multiplexing	Power group	Comments
14 / R1	CPAD14	CSI_MCLK	CSI_MCLK	ALT0: CSI_MCLK ALT1: USDHC2_CD_B ALT2: NAND_CE2_B ALT3: I2C1_SDA ALT4: EIM_CS0_B ALT5: GPIO4_IO17 ALT6: SNVS_VIO_5_CTL ALT7: ALT8: UART6_TX	NVCC_CSI	
15 / T1	CPAD15	CSI_PIXCLK	CSI_PIXCLK	ALT0: CSI_PIXCLK ALT1: USDHC2_WP ALT2: NAND_CE3_B ALT3: I2C1_SCL ALT4: EIM_OE ALT5: GPIO4_IO18 ALT6: SNVS_HP_VIO_5 ALT7: ALT8: UART6_RX	NVCC_CSI	
16 / U1	CPAD16	CSI_DATA1	CSI_DATA01	ALT0: CSI_DATA03 ALT1: USDHC2_DATA1 ALT2: SIM1_PORT1_SVEN ALT3: ECSPi2_SS0 ALT4: EIM_AD01 ALT5: GPIO4_IO22 ALT6: SAI1_MCLK ALT7: ALT8: UART5_RX	NVCC_CSI	

Castellated pad	ConnectCore 6UL pad	ConnectCore 6UL signal name	i.MX6UL pad name	Multiplexing	Power group	Comments
17 / V1	CPAD17	CSI_HSYNC	CSI_HSYNC	ALT0: CSI_HSYNC ALT1: USDHC2_CMD ALT2: SIM1_PORT1_PD ALT3: I2C2_SCL ALT4: EIM_LBA_B ALT5: GPIO4_IO20 ALT6: PWM8_OUT ALT7: ALT8: UART6_CTS_B	NVCC_CSI	
18 / W1	CPAD18	GPIO1_5	GPIO1_IO05	ALT0: ENET2_REF_CLK2 ALT1: PWM4_OUT ALT2: USB_OTG2_ID ALT3: CSI_FIELD ALT4: USDHC1_VSELECT ALT5: GPIO1_IO05 ALT6: ENET2_1588_EVENT0_OUT ALT7: ALT8: UART5_RX	NVCC_GPIO	
19 / Y1	CPAD19	BOOT_MODE1			VDD_SNVS_IN	

Castellated pad	ConnectCore 6UL pad	ConnectCore 6UL signal name	i.MX6UL pad name	Multiplexing	Power group	Comments
20 / AA2	CPAD20	CSI_DATA0	CSI_DATA00	ALT0: CSI_DATA02 ALT1: USDHC2_DATA0 ALT2: SIM1_PORT1_RST_B ALT3: ECSPi2_SCLK ALT4: EIM_AD00 ALT5: GPIO4_IO21 ALT6: SRC_INT_BOOT ALT7: ALT8: UART5_TX	NVCC_CSI	
21 / AA3	CPAD21	CSI_VSYNC	CSI_VSYNC	ALT0: CSI_VSYNC ALT1: USDHC2_CLK ALT2: SIM1_PORT1_CLK ALT3: I2C2_SDA ALT4: EIM_RW ALT5: GPIO4_IO19 ALT6: PWM7_OUT ALT7: ALT8: UART6_RTS_B	NVCC_CSI	
22 / AA4	CPAD22	CSI_DATA2	CSI_DATA02	ALT0: CSI_DATA04 ALT1: USDHC2_DATA2 ALT2: SIM1_PORT1_TRXD ALT3: ECSPi2_MOSI ALT4: EIM_AD02 ALT5: GPIO4_IO23 ALT6: SAI1_RX_SYNC ALT7: ALT8: UART5_RTS_B	NVCC_CSI	

Castellated pad	ConnectCore 6UL pad	ConnectCore 6UL signal name	i.MX6UL pad name	Multiplexing	Power group	Comments
23 / AA5	CPAD23	CSI_DATA3	CSI_DATA03	ALT0: CSI_DATA05 ALT1: USDHC2_DATA3 ALT2: SIM2_PORT1_PD ALT3: ECSPI2_MISO ALT4: EIM_AD03 ALT5: GPIO4_IO24 ALT6: SAI1_RX_BCLK ALT7: ALT8: UART5_CTS_B	NVCC_CSI	
24 / AA6	CPAD24	UART5_TX	UART5_TX_DATA	ALT0: UART5_TX ALT1: ENET2_CRIS ALT2: I2C2_SCL ALT3: CSI_DATA14 ALT4: CSU_CSU_ALARM_AUT00 ALT5: GPIO1_IO30 ALT6: ALT7: ALT8: ECSPI2_MOSI	NVCC_UART	
25 / AA7	CPAD25	UART5_RX	UART5_RX_DATA	ALT0: UART5_RX ALT1: ENET2_COL ALT2: I2C2_SDA ALT3: CSI_DATA15 ALT4: CSU_CSU_INT_DEB ALT5: GPIO1_IO31 ALT6: ALT7: ALT8: ECSPI2_MISO	NVCC_UART	

Castellated pad	ConnectCore 6UL pad	ConnectCore 6UL signal name	i.MX6UL pad name	Multiplexing	Power group	Comments
26 / AA8	CPAD26	USB_OTG1_P	USB_OTG1_DP			USB differential data line
27 / AA9	CPAD27	USB_OTG1_N	USB_OTG1_DN			USB differential data line
28 / AA10	CPAD28	GND	-		-	
29 / AA11	CPAD29	USB_OTG1_VBUS	USB_OTG1_VBUS		USB_VBUS	Power line
30 / AA12	CPAD30	GPIO1_4	GPIO1_IO04	ALT0: ENET1_REF_CLK1 ALT1: PWM3_OUT ALT2: USB_OTG1_PWR ALT3: ANATOP_24M_OUT ALT4: USDHC1_RESET_B ALT5: GPIO1_IO04 ALT6: ENET2_1588_EVENT0_IN ALT7: ALT8: UART5_TX	NVCC_GPIO	

Castellated pad	ConnectCore 6UL pad	ConnectCore 6UL signal name	i.MX6UL pad name	Multiplexing	Power group	Comments
31 / AA13	CPAD31	GPIO1_0	GPIO1_IO00	ALT0: I2C2_SCL ALT1: GPT1_CAPTURE1 ALT2: USB_OTG1_ID ALT3: ENET1_REF_CLK1 ALT4: MQS_RIGHT ALT5: GPIO1_IO00 ALT6: ENET1_1588_EVENT0_IN ALT7: SRC_SYSTEM_RESET ALT8: WDOG3_WDOG_B	NVCC_GPIO	
32 / AA14	CPAD32	GPIO1_1	GPIO1_IO01	ALT0: I2C2_SDA ALT1: GPT1_COMPARE1 ALT2: USB_OTG1_OC ALT3: ENET2_REF_CLK2 ALT4: MQS_LEFT ALT5: GPIO1_IO01 ALT6: ENET1_1588_EVENT0_OUT ALT7: SRC_EARLY_RESET ALT8: WDOG1_WDOG_B	NVCC_GPIO	

Castellated pad	ConnectCore 6UL pad	ConnectCore 6UL signal name	i.MX6UL pad name	Multiplexing	Power group	Comments
33 / AA15	CPAD33	JTAG_MOD	JTAG_MOD	ALT0: SJC_MOD ALT1: GPT2_CLK ALT2: SPDIF_OUT ALT3: XTALOSC_REF_CLK_25M ALT4: CCM_PMIC_READY ALT5: GPIO1_IO10 ALT6: SDMA_EXT_EVENT00 ALT7: ALT8:	NVCC_GPIO	
34 / AA16	CPAD34	JTAG_TMS	JTAG_TMS	ALT0: SJC_TMS ALT1: GPT2_CAPTURE1 ALT2: SAI2_MCLK ALT3: CCM_CLKO1 ALT4: CCM_WAIT ALT5: GPIO1_IO11 ALT6: SDMA_EXT_EVENT01 ALT7: ALT8: EPIT1_OUT	NVCC_GPIO	
35 / AA17	CPAD35	USB_OTG2_P	USB_OTG2_DP			USB differential data line
36 / AA18	CPAD36	USB_OTG2_N	USB_OTG2_DN			USB differential data line

Castellated pad	ConnectCore 6UL pad	ConnectCore 6UL signal name	i.MX6UL pad name	Multiplexing	Power group	Comments
37 / AA19	CPAD37	GPIO1_7	GPIO1_IO07	ALT0: ENET1_MDC ALT1: ENET2_MDC ALT2: USB_OTG_HOST_MODE ALT3: CSI_PIXCLK ALT4: USDHC2_CD_B ALT5: GPIO1_IO07 ALT6: CCM_STOP ALT7: ALT8: UART1_RTS_B	NVCC_GPIO	
38 / AA20	CPAD38	GPIO1_6	GPIO1_IO06	ALT0: ENET1_MDIO ALT1: ENET2_MDIO ALT2: USB_OTG_PWR_WAKE ALT3: CSI_MCLK ALT4: USDHC2_WP ALT5: GPIO1_IO06 ALT6: CCM_WAIT ALT7: CCM_REF_EN_B ALT8: UART1_CTS_B	NVCC_GPIO	
39 / Y21	CPAD39	JTAG_TDO	JTAG_TDO	ALT0: SJC_TDO ALT1: GPT2_CAPTURE2 ALT2: SAI2_TX_SYNC ALT3: CCM_CLKO2 ALT4: CCM_STOP ALT5: GPIO1_IO12 ALT6: MQS_RIGHT ALT7: ALT8: EPIT2_OUT	NVCC_GPIO	

Castellated pad	ConnectCore 6UL pad	ConnectCore 6UL signal name	i.MX6UL pad name	Multiplexing	Power group	Comments
40 / W21	CPAD40	JTAG_TCK	JTAG_TCK	ALT0: SJC_TCK ALT1: GPT2_COMPARE2 ALT2: SAI2_RX_DATA ALT3: ALT4: PWM7_OUT ALT5: GPIO1_IO14 ALT6: OSC32K_32K_OUT ALT7: ALT8: SIM2_POWER_FAIL	NVCC_GPIO	
41 / V21	CPAD41	JTAG_TDI	JTAG_TDI	ALT0: SJC_TDI ALT1: GPT2_COMPARE1 ALT2: SAI2_TX_BCLK ALT3: ALT4: PWM6_OUT ALT5: GPIO1_IO13 ALT6: MQS_LEFT ALT7: ALT8: SIM1_POWER_FAIL	NVCC_GPIO	

Castellated pad	ConnectCore 6UL pad	ConnectCore 6UL signal name	i.MX6UL pad name	Multiplexing	Power group	Comments
42 / U21	CPAD42	JTAG_nTRST	JTAG_TRST_B	ALT0: SJC_TRSTB ALT1: GPT2_COMPARE3 ALT2: SAI2_TX_DATA ALT3: ALT4: PWM8_OUT ALT5: GPIO1_IO15 ALT6: ANATOP_24M_OUT ALT7: ALT8: CAAM_RNG_OSC_OBS	NVCC_GPIO	
43 / T21	CPAD43	UART2_TX	UART2_TX_DATA	ALT0: UART2_TX ALT1: ENET1_TDATA02 ALT2: I2C4_SCL ALT3: CSI_DATA06 ALT4: GPT1_CAPTURE1 ALT5: GPIO1_IO20 ALT6: ALT7: ALT8: ECSPI3_SS0	NVCC_UART	

Castellated pad	ConnectCore 6UL pad	ConnectCore 6UL signal name	i.MX6UL pad name	Multiplexing	Power group	Comments
44 / R21	CPAD44	UART2_RX	UART2_RX_DATA	ALT0: UART2_RX ALT1: ENET1_TDATA03 ALT2: I2C4_SDA ALT3: CSI_DATA07 ALT4: GPT1_CAPTURE2 ALT5: GPIO1_IO21 ALT6: ALT7: SJC_DONE ALT8: ECSPI3_SCLK	NVCC_UART	
45 / P21	CPAD45	GND	-		-	
46 / N21	CPAD46	UART2_CTS#	UART2_CTS_B	ALT0: UART2_CTS_B ALT1: ENET1_CRS ALT2: FLEXCAN2_TX ALT3: CSI_DATA08 ALT4: GPT1_COMPARE2 ALT5: GPIO1_IO22 ALT6: ALT7: SJC_DE_B ALT8: ECSPI3_MOSI	NVCC_UART	

Castellated pad	ConnectCore 6UL pad	ConnectCore 6UL signal name	i.MX6UL pad name	Multiplexing	Power group	Comments
47 / M21	CPAD47	UART2_RTS#	UART2_RTS_B	ALT0: UART2_RTS_B ALT1: ENET1_COL ALT2: FLEXCAN2_RX ALT3: CSI_DATA09 ALT4: GPT1_COMPARE3 ALT5: GPIO1_IO23 ALT6: ALT7: SJC_FAIL ALT8: ECSPI3_MISO	NVCC_UART	
48 / L21	CPAD48	ENET1_RX_DATA0	ENET1_RX_DATA0	ALT0: ENET1_RDATA00 ALT1: UART4_RTS_B ALT2: PWM1_OUT ALT3: CSI_DATA16 ALT4: FLEXCAN1_TX ALT5: GPIO2_IO00 ALT6: KPP_ROW00 ALT7: ALT8: USDHC1_LCTL	NVCC_ENET	
49 / K21	CPAD49	ENET1_RX_EN	ENET1_RX_EN	ALT0: ENET1_RX_EN ALT1: UART5_RTS_B ALT2: OSC32K_32K_OUT ALT3: CSI_DATA18 ALT4: FLEXCAN2_TX ALT5: GPIO2_IO02 ALT6: KPP_ROW01 ALT7: ALT8: USDHC1_VSELECT	NVCC_ENET	

Castellated pad	ConnectCore 6UL pad	ConnectCore 6UL signal name	i.MX6UL pad name	Multiplexing	Power group	Comments
50 / J21	CPAD50	ENET1_RX_ER	ENET1_RX_ER	ALT0: ENET1_RX_ER ALT1: UART7_RTS_B ALT2: PWM8_OUT ALT3: CSI_DATA23 ALT4: EIM_CRE ALT5: GPIO2_IO07 ALT6: KPP_COL03 ALT7: ALT8: GPT1_CAPTURE2	NVCC_ENET	
51 / H21	CPAD51	ENET1_TX_DATA1	ENET1_TX_DATA1	ALT0: ENET1_TDATA01 ALT1: UART6_CTS_B ALT2: PWM5_OUT ALT3: CSI_DATA20 ALT4: ENET2_MDIO ALT5: GPIO2_IO04 ALT6: KPP_ROW02 ALT7: ALT8: WDOG1_WDOG_RST_B_DEB	NVCC_ENET	
52 / G21	CPAD52	ENET1_TX_EN	ENET1_TX_EN	ALT0: ENET1_TX_EN ALT1: UART6_RTS_B ALT2: PWM6_OUT ALT3: CSI_DATA21 ALT4: ENET2_MDC ALT5: GPIO2_IO05 ALT6: KPP_COL02 ALT7: ALT8: WDOG2_WDOG_RST_B_DEB	NVCC_ENET	

Castellated pad	ConnectCore 6UL pad	ConnectCore 6UL signal name	i.MX6UL pad name	Multiplexing	Power group	Comments
53 / F21	CPAD53	ENET1_TX_CLK	ENET1_TX_CLK	ALT0: ENET1_TX_CLK ALT1: UART7_CTS_B ALT2: PWM7_OUT ALT3: CSI_DATA22 ALT4: ENET1_REF_CLK1 ALT5: GPIO2_IO06 ALT6: KPP_ROW03 ALT7: ALT8: GPT1_CLK	NVCC_ENET	
54 / E21	CPAD54	ENET1_RX_DATA1	ENET1_RX_DATA1	ALT0: ENET1_RDATA01 ALT1: UART4_CTS_B ALT2: PWM2_OUT ALT3: CSI_DATA17 ALT4: FLEXCAN1_RX ALT5: GPIO2_IO01 ALT6: KPP_COL00 ALT7: ALT8: USDHC2_LCTL	NVCC_ENET	
55 / D21	CPAD55	ENET1_TX_DATA0	ENET1_TX_DATA0	ALT0: ENET1_TDATA00 ALT1: UART5_CTS_B ALT2: ANATOP_24M_OUT ALT3: CSI_DATA19 ALT4: FLEXCAN2_RX ALT5: GPIO2_IO03 ALT6: KPP_COL01 ALT7: ALT8: USDHC2_VSELECT	NVCC_ENET	

Castellated pad	ConnectCore 6UL pad	ConnectCore 6UL signal name	i.MX6UL pad name	Multiplexing	Power group	Comments
56 / C21	CPAD56	LCD_CLK	LCD_CLK	ALT0: LCDIF_CLK ALT1: LCDIF_WR_RWN ALT2: UART4_TX ALT3: SAI3_MCLK ALT4: EIM_CS2_B ALT5: GPIO3_IO00 ALT6: ALT7: ALT8: WDOG1_WDOG_RST_B_DEB	NVCC_LCD	
57 / B21	CPAD57	LCD_HSYNC	LCD_HSYNC	ALT0: LCDIF_HSYNC ALT1: LCDIF_RS ALT2: UART4_CTS_B ALT3: SAI3_TX_BCLK ALT4: WDOG3_WDOG_RST_B_DEB ALT5: GPIO3_IO02 ALT6: ALT7: ALT8: ECSPi2_SS1	NVCC_LCD	
58 / A20	CPAD58	LCD_DATA4	LCD_DATA04	ALT0: LCDIF_DATA04 ALT1: UART8_CTS_B ALT2: ALT3: ENET2_1588_EVENT2_IN ALT4: SPDIF_SR_CLK ALT5: GPIO3_IO09 ALT6: SRC_BT_CFG04 ALT7: ALT8: SAI1_TX_DATA	NVCC_LCD	

Castellated pad	ConnectCore 6UL pad	ConnectCore 6UL signal name	i.MX6UL pad name	Multiplexing	Power group	Comments
59 / A19	CPAD59	LCD_RESET	LCD_RESET	ALT0: LCDIF_RESET ALT1: LCDIF_CS ALT2: CA7_MX6UL_EVENT1 ALT3: SAI3_TX_DATA ALT4: WDOG1_WDOG_ANY ALT5: GPIO3_IO04 ALT6: ALT7: ALT8: ECSPi2_SS3	NVCC_LCD	
60 / A18	CPAD60	LCD_DATA0	LCD_DATA00	ALT0: LCDIF_DATA00 ALT1: PWM1_OUT ALT2: ALT3: ENET1_1588_EVENT2_IN ALT4: I2C3_SDA ALT5: GPIO3_IO05 ALT6: SRC_BT_CFG00 ALT7: ALT8: SAI1_MCLK	NVCC_LCD	

Castellated pad	ConnectCore 6UL pad	ConnectCore 6UL signal name	i.MX6UL pad name	Multiplexing	Power group	Comments
61 / A17	CPAD61	LCD_DATA3	LCD_DATA03	ALT0: LCDIF_DATA03 ALT1: PWM4_OUT ALT2: ALT3: ENET1_1588_EVENT3_OUT ALT4: I2C4_SCL ALT5: GPIO3_IO08 ALT6: SRC_BT_CFG03 ALT7: ALT8: SAI1_RX_DATA	NVCC_LCD	
62 / A16	CPAD62	LCD_DATA6	LCD_DATA06	ALT0: LCDIF_DATA06 ALT1: UART7_CTS_B ALT2: ALT3: ENET2_1588_EVENT3_IN ALT4: SPDIF_LOCK ALT5: GPIO3_IO11 ALT6: SRC_BT_CFG06 ALT7: ALT8: ECSP11_SS2	NVCC_LCD	
63 / A15	CPAD63	LCD_DATA7	LCD_DATA07	ALT0: LCDIF_DATA07 ALT1: UART7_RTS_B ALT2: ALT3: ENET2_1588_EVENT3_OUT ALT4: SPDIF_EXT_CLK ALT5: GPIO3_IO12 ALT6: SRC_BT_CFG07 ALT7: ALT8: ECSP11_SS3	NVCC_LCD	

Castellated pad	ConnectCore 6UL pad	ConnectCore 6UL signal name	i.MX6UL pad name	Multiplexing	Power group	Comments
64 / A14	CPAD64	LCD_DATA5	LCD_DATA05	ALT0: LCDIF_DATA05 ALT1: UART8_RTS_B ALT2: ALT3: ENET2_1588_EVENT2_OUT ALT4: SPDIF_OUT ALT5: GPIO3_IO10 ALT6: SRC_BT_CFG05 ALT7: ALT8: ECSP11_SS1	NVCC_LCD	
65 / A13	CPAD65	GND	-		-	
66 / A12	CPAD66	LCD_DATA2	LCD_DATA02	ALT0: LCDIF_DATA02 ALT1: PWM3_OUT ALT2: ALT3: ENET1_1588_EVENT3_IN ALT4: I2C4_SDA ALT5: GPIO3_IO07 ALT6: SRC_BT_CFG02 ALT7: ALT8: SAI1_TX_BCLK	NVCC_LCD	

Castellated pad	ConnectCore 6UL pad	ConnectCore 6UL signal name	i.MX6UL pad name	Multiplexing	Power group	Comments
67 / A11	CPAD67	LCD_VSYNC	LCD_VSYNC	ALT0: LCDIF_VSYNC ALT1: LCDIF_BUSY ALT2: UART4_RTS_B ALT3: SAI3_RX_DATA ALT4: WDOG2_WDOG_B ALT5: GPIO3_IO03 ALT6: ALT7: ALT8: ECSPi2_SS2	NVCC_LCD	
68 / A10	CPAD68	LCD_DATA1	LCD_DATA01	ALT0: LCDIF_DATA01 ALT1: PWM2_OUT ALT2: ALT3: ENET1_1588_EVENT2_OUT ALT4: I2C3_SCL ALT5: GPIO3_IO06 ALT6: SRC_BT_CFG01 ALT7: ALT8: SAI1_TX_SYNC	NVCC_LCD	
69 / A9	CPAD69	LCD_ENABLE	LCD_ENABLE	ALT0: LCDIF_ENABLE ALT1: LCDIF_RD_E ALT2: UART4_RX ALT3: SAI3_TX_SYNC ALT4: EIM_CS3_B ALT5: GPIO3_IO01 ALT6: ALT7: ALT8: ECSPi2_RDY	NVCC_LCD	

Castellated pad	ConnectCore 6UL pad	ConnectCore 6UL signal name	i.MX6UL pad name	Multiplexing	Power group	Comments
70 / A8	CPAD70	VCC_MCA	-		VCC_MCA	Power line
71 / A7	CPAD71	SWD_DIO/MCA_IO7	-		VCC_MCA	
72 / A6	CPAD72	SWD_CLK/PWR_IO	-		VCC_MCA	Input power on/off line of the module (active low)
73 / A5	CPAD73	MCA_RESET	-		VCC_MCA	Input reset line of the module (active low)
74 / A4	CPAD74	MCA_VIN_DET	-		VCC_MCA	
75 / A3	CPAD75	MCA_IO4	-	MCA GPIO/ADC	VCC_MCA	
76 / A2	CPAD76	MCA_IO0	-	MCA GPIO/ADC	VCC_MCA	

LGA pad signals and multiplexing

LGA pad	ConnectCore 6UL pad	ConnectCore 6UL signal name	i.MX6UL pad name	Multiplexing	Power group	Comments
A2	LGA_ A2	MCA_IO0	-	MCA GPIO/ADC	VCC_MCA	
A3	LGA_ A3	MCA_IO4	-	MCA GPIO/ADC	VCC_MCA	
A4	LGA_ A4	MCA_VIN_DET	-		VCC_MCA	
A5	LGA_ A5	MCA_RESET	-		VCC_MCA	Input reset line of the module (active low)
A6	LGA_ A6	SWD_CLK/PWR_IO	-		VCC_MCA	Input power on/off line of the module (active low)
A7	LGA_ A7	SWD_DIO/MCA_IO7	-		VCC_MCA	
A8	LGA_ A8	VCC_MCA	-		VCC_MCA	Power line
A9	LGA_ A9	LCD_ENABLE	LCD_ENABLE	ALT0: LCDIF_ENABLE ALT1: LCDIF_RD_E ALT2: UART4_RX ALT3: SAI3_TX_SYNC ALT4: EIM_CS3_B ALT5: GPIO3_IO01 ALT6: ALT7: ALT8: ECSPI2_RDY	NVCC_LCD	

LGA pad	ConnectCore 6UL pad	ConnectCore 6UL signal name	i.MX6UL pad name	Multiplexing	Power group	Comments
A10	LGA_ A10	LCD_DATA1	LCD_ DATA01	ALT0: LCDIF_DATA01 ALT1: PWM2_OUT ALT2: ALT3: ENET1_1588_ EVENT2_OUT ALT4: I2C3_SCL ALT5: GPIO3_IO06 ALT6: SRC_BT_ CFG01 ALT7: ALT8: SAI1_TX_SYNC	NVCC_LCD	
A11	LGA_ A11	LCD_VSYNC	LCD_VSYNC	ALT0: LCDIF_VSYNC ALT1: LCDIF_BUSY ALT2: UART4_RTS_B ALT3: SAI3_RX_DATA ALT4: WDOG2_ WDOG_B ALT5: GPIO3_IO03 ALT6: ALT7: ALT8: ECSPI2_SS2	NVCC_LCD	

LGA pad	ConnectCore 6UL pad	ConnectCore 6UL signal name	i.MX6UL pad name	Multiplexing	Power group	Comments
A12	LGA_ A12	LCD_DATA2	LCD_ DATA02	ALT0: LCDIF_DATA02 ALT1: PWM3_OUT ALT2: ALT3: ENET1_1588_ EVENT3_IN ALT4: I2C4_SDA ALT5: GPIO3_IO07 ALT6: SRC_BT_ CFG02 ALT7: ALT8: SAI1_TX_BCLK	NVCC_LCD	
A13	LGA_ A13	GND	-		-	
A14	LGA_ A14	LCD_DATA5	LCD_ DATA05	ALT0: LCDIF_DATA05 ALT1: UART8_RTS_B ALT2: ALT3: ENET2_1588_ EVENT2_OUT ALT4: SPDIF_OUT ALT5: GPIO3_IO10 ALT6: SRC_BT_ CFG05 ALT7: ALT8: ECSPI1_SS1	NVCC_LCD	

LGA pad	ConnectCore 6UL pad	ConnectCore 6UL signal name	i.MX6UL pad name	Multiplexing	Power group	Comments
A15	LGA_ A15	LCD_DATA7	LCD_ DATA07	ALT0: LCDIF_DATA07 ALT1: UART7_RTS_B ALT2: ALT3: ENET2_1588_ EVENT3_OUT ALT4: SPDIF_EXT_ CLK ALT5: GPIO3_IO12 ALT6: SRC_BT_ CFG07 ALT7: ALT8: ECSPI1_SS3	NVCC_LCD	
A16	LGA_ A16	LCD_DATA6	LCD_ DATA06	ALT0: LCDIF_DATA06 ALT1: UART7_CTS_B ALT2: ALT3: ENET2_1588_ EVENT3_IN ALT4: SPDIF_LOCK ALT5: GPIO3_IO11 ALT6: SRC_BT_ CFG06 ALT7: ALT8: ECSPI1_SS2	NVCC_LCD	

LGA pad	ConnectCore 6UL pad	ConnectCore 6UL signal name	i.MX6UL pad name	Multiplexing	Power group	Comments
A17	LGA_ A17	LCD_DATA3	LCD_ DATA03	ALT0: LCDIF_DATA03 ALT1: PWM4_OUT ALT2: ALT3: ENET1_1588_ EVENT3_OUT ALT4: I2C4_SCL ALT5: GPIO3_IO08 ALT6: SRC_BT_ CFG03 ALT7: ALT8: SAI1_RX_DATA	NVCC_LCD	
A18	LGA_ A18	LCD_DATA0	LCD_ DATA00	ALT0: LCDIF_DATA00 ALT1: PWM1_OUT ALT2: ALT3: ENET1_1588_ EVENT2_IN ALT4: I2C3_SDA ALT5: GPIO3_IO05 ALT6: SRC_BT_ CFG00 ALT7: ALT8: SAI1_MCLK	NVCC_LCD	

LGA pad	ConnectCore 6UL pad	ConnectCore 6UL signal name	i.MX6UL pad name	Multiplexing	Power group	Comments
A19	LGA_A19	LCD_RESET	LCD_RESET	ALT0: LCDIF_RESET ALT1: LCDIF_CS ALT2: CA7_MX6UL_EVENTI ALT3: SAI3_TX_DATA ALT4: WDOG1_WDOG_ANY ALT5: GPIO3_IO04 ALT6: ALT7: ALT8: ECSPI2_SS3	NVCC_LCD	
A20	LGA_A20	LCD_DATA4	LCD_DATA04	ALT0: LCDIF_DATA04 ALT1: UART8_CTS_B ALT2: ALT3: ENET2_1588_EVENT2_IN ALT4: SPDIF_SR_CLK ALT5: GPIO3_IO09 ALT6: SRC_BT_CFG04 ALT7: ALT8: SAI1_TX_DATA	NVCC_LCD	
A21	LGA_A21	GND	-		-	
B1	LGA_B1	VCC_LICELL	-		VCC_LICELL	Coin cell supply
B2	LGA_B2	MCA_IO1	-	MCA GPIO/ADC		
B3	LGA_B3	-	-	-		
B4	LGA_B4	-	-	-		

LGA pad	ConnectCore 6UL pad	ConnectCore 6UL signal name	i.MX6UL pad name	Multiplexing	Power group	Comments
B5	LGA_B5	MCA_IO2/EXT_VREF	-	MCA GPIO		
B6	LGA_B6	MCA_IO5	-	MCA GPIO/ADC		
B7	LGA_B7	-	-	-	-	Reserved
B8	LGA_B8	NAND_CLE	NAND_CLE	ALT0: NAND_CLE ALT1: USDHC1_DATA7 ALT2: QSPI_A_DATA03 ALT3: ECSPI3_MISO ALT4: EIM_ADDR16 ALT5: GPIO4_IO15 ALT6: ALT7: ALT8: UART3_RTS_B	NVCC_NAND	Leave this line floating if you want to use the on-module NAND
B9	LGA_B9	NAND_ALE	NAND_ALE	ALT0: NAND_ALE ALT1: USDHC2_RESET_B ALT2: QSPI_A_DQS ALT3: PWM3_OUT ALT4: EIM_ADDR17 ALT5: GPIO4_IO10 ALT6: ALT7: ALT8: ECSPI3_SS1	NVCC_NAND	Leave this line floating if you want to use the on-module NAND

LGA pad	ConnectCore 6UL pad	ConnectCore 6UL signal name	i.MX6UL pad name	Multiplexing	Power group	Comments
B10	LGA_B10	NAND_CE0#	NAND_CE0_B	ALT0: NAND_CE0_B ALT1: USDHC1_DATA5 ALT2: QSPI_A_DATA01 ALT3: ECSPI3_SCLK ALT4: EIM_DTACK_B ALT5: GPIO4_IO13 ALT6: ALT7: ALT8: UART3_RX	NVCC_NAND	Leave this line floating if you want to use the on-module NAND
B11	LGA_B11	NAND_WE#	NAND_WE_B	ALT0: NAND_WE_B ALT1: USDHC2_CMD ALT2: QSPI_B_SS0_B ALT3: KPP_COL00 ALT4: EIM_EB1_B ALT5: GPIO4_IO01 ALT6: ALT7: ALT8: ECSPI3_SS3	NVCC_NAND	Leave this line floating if you want to use the on-module NAND
B12	LGA_B12	GND	-		-	
B13	LGA_B13	RF_ANT_EXT	-			
B14	LGA_B14	GND	-		-	
B15	LGA_B15	RF1_INT/nEXT	-			
B16	LGA_B16	GND	-		-	
B17	LGA_B17	WLAN_RF_KILL	-		VDDIO_GPIO2	

LGA pad	ConnectCore 6UL pad	ConnectCore 6UL signal name	i.MX6UL pad name	Multiplexing	Power group	Comments
B18	LGA_B18	BT_RF_KILL	-		VDDIO_GPIO2	
B19	LGA_B19	WLAN_LED	-		VDDIO_GPIO2	
B20	LGA_B20	BT_LED	-		VDDIO_GPIO2	
B21	LGA_B21	LCD_HSYNC	LCD_HSYNC	ALT0: LCDIF_HSYNC ALT1: LCDIF_RS ALT2: UART4_CTS_B ALT3: SAI3_TX_BCLK ALT4: WDOG3_WDOG_RST_B_DEB ALT5: GPIO3_IO02 ALT6: ALT7: ALT8: ECSPI2_SS1	NVCC_LCD	
C1	LGA_C1	VSYS	-		VSYS	Power line
C2	LGA_C2	VSYS	-		VSYS	Power line
C3	LGA_C3	MCA_IO3	-	MCA GPIO/ADC	VCC_MCA	
C4	LGA_C4	MCA_IO6/CLKOUT32K	-	MCA GPIO/32KHz output	VCC_MCA	
C5	LGA_C5	GND	-		-	

LGA pad	ConnectCore 6UL pad	ConnectCore 6UL signal name	i.MX6UL pad name	Multiplexing	Power group	Comments
C6	LGA_C6	NAND_DATA0	NAND_DATA00	ALT0: NAND_DATA00 ALT1: USDHC2_DATA0 ALT2: QSPI_B_SS1_B ALT3: KPP_ROW01 ALT4: EIM_AD08 ALT5: GPIO4_IO02 ALT6: ALT7: ALT8: ECSPI4_RDY	NVCC_NAND	Leave this line floating if you want to use the on-module NAND
C7	LGA_C7	NAND_DATA1	NAND_DATA01	ALT0: NAND_DATA01 ALT1: USDHC2_DATA1 ALT2: QSPI_B_DQS ALT3: KPP_COL01 ALT4: EIM_AD09 ALT5: GPIO4_IO03 ALT6: ALT7: ALT8: ECSPI4_SS1	NVCC_NAND	Leave this line floating if you want to use the on-module NAND

LGA pad	ConnectCore 6UL pad	ConnectCore 6UL signal name	i.MX6UL pad name	Multiplexing	Power group	Comments
C8	LGA_C8	NAND_DATA2	NAND_DATA02	ALT0: NAND_DATA02 ALT1: USDHC2_DATA2 ALT2: QSPI_B_DATA00 ALT3: KPP_ROW02 ALT4: EIM_AD10 ALT5: GPIO4_IO04 ALT6: ALT7: ALT8: ECSPI4_SS2	NVCC_NAND	Leave this line floating if you want to use the on-module NAND
C9	LGA_C9	NAND_RE#	NAND_RE_B	ALT0: NAND_RE_B ALT1: USDHC2_CLK ALT2: QSPI_B_SCLK ALT3: KPP_ROW00 ALT4: EIM_EB0_B ALT5: GPIO4_IO00 ALT6: ALT7: ALT8: ECSPI3_SS2	NVCC_NAND	Leave this line floating if you want to use the on-module NAND
C10	LGA_C10	NAND_WP#	NAND_WP_B	ALT0: NAND_WP_B ALT1: USDHC1_RESET_B ALT2: QSPI_A_SCLK ALT3: PWM4_OUT ALT4: EIM_BCLK ALT5: GPIO4_IO11 ALT6: ALT7: ALT8: ECSPI3_RDY	NVCC_NAND	Leave this line floating if you want to use the on-module NAND

LGA pad	ConnectCore 6UL pad	ConnectCore 6UL signal name	i.MX6UL pad name	Multiplexing	Power group	Comments
C11	LGA_C11	GND	-		-	
C12	LGA_C12	VCC_NAND	-		VCC_NAND	Power line
C13	LGA_C13	GND	-		-	
C14	LGA_C14	GPS_COEX	-		VDDIO_GPIO1	
C15	LGA_C15	NAND_DATA7	NAND_DATA07	ALT0: NAND_DATA07 ALT1: USDHC2_DATA7 ALT2: QSPI_A_SS1_B ALT3: ECSPI4_SS0 ALT4: EIM_AD15 ALT5: GPIO4_IO09 ALT6: ALT7: ALT8: UART2_RTS_B	NVCC_NAND	Leave this line floating if you want to use the on-module NAND
C16	LGA_C16	-	-		-	
C17	LGA_C17	PCM_OUT	-		VDDIO_GPIO1	
C18	LGA_C18	PCM_SYNC	-		VDDIO_GPIO1	
C19	LGA_C19	GND	-		-	
C20	LGA_C20	PCM_CLK	-		VDDIO_GPIO1	

LGA pad	ConnectCore 6UL pad	ConnectCore 6UL signal name	i.MX6UL pad name	Multiplexing	Power group	Comments
C21	LGA_C21	LCD_CLK	LCD_CLK	ALT0: LCDIF_CLK ALT1: LCDIF_WR_RWN ALT2: UART4_TX ALT3: SAI3_MCLK ALT4: EIM_CS2_B ALT5: GPIO3_IO00 ALT6: ALT7: ALT8: WDOG1_WDOG_RST_B_DEB	NVCC_LCD	
D1	LGA_D1	VPWR	-		VPWR	Power line
D2	LGA_D2	GND	-		-	
D3	LGA_D3	LDO2_EXT	-		VLDO2	Power line
D4	LGA_D4	LDO4_EXT	-		VLDO4	Power line. On SBC, configured to 1.8 V.
D5	LGA_D5	GND	-		-	
D6	LGA_D6	NAND_DATA4	NAND_DATA04	ALT0: NAND_DATA04 ALT1: USDHC2_DATA4 ALT2: QSPI_B_DATA02 ALT3: ECSPI4_SCLK ALT4: EIM_AD12 ALT5: GPIO4_IO06 ALT6: ALT7: ALT8: UART2_TX	NVCC_NAND	Leave this line floating if you want to use the on-module NAND

LGA pad	ConnectCore 6UL pad	ConnectCore 6UL signal name	i.MX6UL pad name	Multiplexing	Power group	Comments
D7	LGA_D7	GND	-		-	
D8	LGA_D8	PF3000_SWBSTFB	-		-	Power line (PMIC boost output)
D9	LGA_D9	PF3000_SWBSTLX	-		-	Power line (PMIC boost output)
D10	LGA_D10	GND	-		-	
D11	LGA_D11	NAND_READY#	NAND_READY_B	ALT0: NAND_READY_B ALT1: USDHC1_DATA4 ALT2: QSPI_A_DATA00 ALT3: ECSP13_SS0 ALT4: EIM_CS1_B ALT5: GPIO4_IO12 ALT6: ALT7: ALT8: UART3_TX	NVCC_NAND	Leave this line floating if you want to use the on-module NAND
D12	LGA_D12	VDD_SNV3_3V3	-		VDD_SNV3_3V3	Power line (when coin cell connected)
D13	LGA_D13	LTE_PRI	-		VDDIO_GPIO1	
D14	LGA_D14	LTE_SYNC	-		VDDIO_GPIO1	
D15	LGA_D15	BT_WAKEUP_SLAVE	-		VDDIO_GPIO1	

LGA pad	ConnectCore 6UL pad	ConnectCore 6UL signal name	i.MX6UL pad name	Multiplexing	Power group	Comments
D16	LGA_D16	BT_UART1_CTS#	UART1_CTS_B	ALT0: UART1_CTS_B ALT1: ENET1_RX_CLK ALT2: USDHC1_WP ALT3: CSI_DATA04 ALT4: ENET2_1588_EVENT1_IN ALT5: GPIO1_IO18 ALT6: ALT7: ALT8: USDHC2_WP	NVCC_UART	Signal only available on module without Bluetooth functionality.
D17	LGA_D17	BT_UART1_TX	UART1_TX_DATA	ALT0: UART1_TX ALT1: ENET1_RDATA02 ALT2: I2C3_SCL ALT3: CSI_DATA02 ALT4: GPT1_COMPARE1 ALT5: GPIO1_IO16 ALT6: ALT7: ALT8: SPDIF_OUT	NVCC_UART	Signal only available on module without Bluetooth functionality.
D18	LGA_D18	BT_UART1_RX	UART1_RX_DATA	ALT0: UART1_RX ALT1: ENET1_RDATA03 ALT2: I2C3_SDA ALT3: CSI_DATA03 ALT4: GPT1_CLK ALT5: GPIO1_IO17 ALT6: ALT7: ALT8: SPDIF_IN	NVCC_UART	Signal only available on module without Bluetooth functionality.

LGA pad	ConnectCore 6UL pad	ConnectCore 6UL signal name	i.MX6UL pad name	Multiplexing	Power group	Comments
D19	LGA_D19	BT_UART1_RTS#	UART1_RTS_B	ALT0: UART1_RTS_B ALT1: ENET1_TX_ER ALT2: USDHC1_CD_B ALT3: CSI_DATA05 ALT4: ENET2_1588_EVENT1_OUT ALT5: GPIO1_IO19 ALT6: ALT7: ALT8: USDHC2_CD_B	NVCC_UART	Signal only available on module without Bluetooth functionality.
D20	LGA_D20	PCM_IN	-		VDDIO_GPIO1	
D21	LGA_D21	ENET1_TX_DATA0	ENET1_TX_DATA0	ALT0: ENET1_TDATA00 ALT1: UART5_CTS_B ALT2: ANATOP_24M_OUT ALT3: CSI_DATA19 ALT4: FLEXCAN2_RX ALT5: GPIO2_IO03 ALT6: KPP_COL01 ALT7: ALT8: USDHC2_VSELECT	NVCC_ENET	
E1	LGA_E1	LDOG	-		LDOG	PMIC output (Front-end LDO)
E2	LGA_E2	-	-	-	-	
E3	LGA_E3	3V3_INT	-		3V3_INT	Power line (PMIC SW1A output)

LGA pad	ConnectCore 6UL pad	ConnectCore 6UL signal name	i.MX6UL pad name	Multiplexing	Power group	Comments
E19	LGA_E19	WLAN_SD1_D4/GPIO4	-		VDDIO_GPIO0	
E20	LGA_E20	WL_EN	-		VDDIO_AO	
E21	LGA_E21	ENET1_RX_DATA1	ENET1_RX_DATA1	ALT0: ENET1_RDATA01 ALT1: UART4_CTS_B ALT2: PWM2_OUT ALT3: CSI_DATA17 ALT4: FLEXCAN1_RX ALT5: GPIO2_IO01 ALT6: KPP_COL00 ALT7: ALT8: USDHC2_LCTL	NVCC_ENET	
F1	LGA_F1	GND	-		-	
F2	LGA_F2	GND	-		-	
F3	LGA_F3	VSYS	-		VSYS	Power line
F19	LGA_F19	WLAN_SDIO_INT_L	-		VDDIO_GPIO0	
F20	LGA_F20	QOW	-		VDDIO_GPIO2	

LGA pad	ConnectCore 6UL pad	ConnectCore 6UL signal name	i.MX6UL pad name	Multiplexing	Power group	Comments
F21	LGA_F21	ENET1_TX_CLK	ENET1_TX_CLK	ALT0: ENET1_TX_CLK ALT1: UART7_CTS_B ALT2: PWM7_OUT ALT3: CSI_DATA22 ALT4: ENET1_REF_CLK1 ALT5: GPIO2_IO06 ALT6: KPP_ROW03 ALT7: ALT8: GPT1_CLK	NVCC_ENET	
G1	LGA_G1	VSYS	-		VSYS	Power line
G2	LGA_G2	VSYS	-		VSYS	Power line
G3	LGA_G3	VSYS	-		VSYS	Power line
G19	LGA_G19	BT_EN	-		VDDIO_AO	
G20	LGA_G20	GND	-		-	
G21	LGA_G21	ENET1_TX_EN	ENET1_TX_EN	ALT0: ENET1_TX_EN ALT1: UART6_RTS_B ALT2: PWM6_OUT ALT3: CSI_DATA21 ALT4: ENET2_MDC ALT5: GPIO2_IO05 ALT6: KPP_COL02 ALT7: ALT8: WDOG2_WDOG_RST_B_DEB	NVCC_ENET	
H1	LGA_H1	VSYS2	-		VSYS2	Power line

LGA pad	ConnectCore 6UL pad	ConnectCore 6UL signal name	i.MX6UL pad name	Multiplexing	Power group	Comments
H2	LGA_H2	VSYS2	-		VSYS2	Power line
H3	LGA_H3	VSYS2	-		VSYS2	Power line
H19	LGA_H19	WLAN_SD1_D7/GPIO1	-		VDDIO_GPIO0	
H20	LGA_H20	BT_WAKEUP_HOST	-		VDDIO_GPIO2	
H21	LGA_H21	ENET1_TX_DATA1	ENET1_TX_DATA1	ALT0: ENET1_TDATA01 ALT1: UART6_CTS_B ALT2: PWM5_OUT ALT3: CSI_DATA20 ALT4: ENET2_MDIO ALT5: GPIO2_IO04 ALT6: KPP_ROW02 ALT7: ALT8: WDOG1_WDOG_RST_B_DEB	NVCC_ENET	
J1	LGA_J1	GND	-		-	
J2	LGA_J2	GND	-		-	
J3	LGA_J3	VSYS2	-		VSYS2	Power line
J19	LGA_J19	WLAN_SD1_D6/GPIO2	-		VDDIO_GPIO0	
J20	LGA_J20	WLAN_SD1_D5/GPIO3	-		VDDIO_GPIO0	

LGA pad	ConnectCore 6UL pad	ConnectCore 6UL signal name	i.MX6UL pad name	Multiplexing	Power group	Comments
J21	LGA_J21	ENET1_RX_ER	ENET1_RX_ER	ALT0: ENET1_RX_ER ALT1: UART7_RTS_B ALT2: PWM8_OUT ALT3: CSI_DATA23 ALT4: EIM_CRE ALT5: GPIO2_IO07 ALT6: KPP_COL03 ALT7: ALT8: GPT1_CAPTURE2	NVCC_ENET	
K1	LGA_K1	3V3_EXT	-		3V3_EXT	Power line (PMIC SW2 output)
K2	LGA_K2	3V3_EXT	-		3V3_EXT	Power line (PMIC SW2 output)
K3	LGA_K3	3V3_EXT	-		3V3_EXT	Power line (PMIC SW2 output)
K19	LGA_K19	WLAN_SD1_CLK	SD1_CLK	ALT0: USDHC1_CLK ALT1: GPT2_COMPARE2 ALT2: SAI2_MCLK ALT3: SPDIF_IN ALT4: EIM_ADDR20 ALT5: GPIO2_IO17 ALT6: ALT7: ALT8: USB_OTG1_OC	VDDIO_GPIO0/NVCC_SD1	Signal only available on module without WLAN functionality.

LGA pad	ConnectCore 6UL pad	ConnectCore 6UL signal name	i.MX6UL pad name	Multiplexing	Power group	Comments
K20	LGA_K20	WLAN_SD1_DATA2	SD1_DATA2	ALT0: USDHC1_DATA2 ALT1: GPT2_CAPTURE1 ALT2: SAI2_RX_DATA ALT3: FLEXCAN2_TX ALT4: EIM_ADDR23 ALT5: GPIO2_IO20 ALT6: CCM_CLKO1 ALT7: ALT8: USB_OTG2_OC	VDDIO_GPIO0/NVCC_SD1	Signal only available on module without WLAN functionality.
K21	LGA_K21	ENET1_RX_EN	ENET1_RX_EN	ALT0: ENET1_RX_EN ALT1: UART5_RTS_B ALT2: OSC32K_32K_OUT ALT3: CSI_DATA18 ALT4: FLEXCAN2_TX ALT5: GPIO2_IO02 ALT6: KPP_ROW01 ALT7: ALT8: USDHC1_VSELECT	NVCC_ENET	

LGA pad	ConnectCore 6UL pad	ConnectCore 6UL signal name	i.MX6UL pad name	Multiplexing	Power group	Comments
L1	LGA_L1	LCD_DATA8	LCD_DATA08	ALT0: LCDIF_DATA08 ALT1: SPDIF_IN ALT2: ALT3: CSI_DATA16 ALT4: EIM_DATA00 ALT5: GPIO3_IO13 ALT6: SRC_BT_CFG08 ALT7: ALT8: FLEXCAN1_TX	VCC_LCD	
L2	LGA_L2	GND	-		-	
L3	LGA_L3	VDDA_ADC_3P3	-		VDDA_ADC_3P3	Power line
L19	LGA_L19	WLAN_SD1_CMD	SD1_CMD	ALT0: USDHC1_CMD ALT1: GPT2_COMPARE1 ALT2: SAI2_RX_SYNC ALT3: SPDIF_OUT ALT4: EIM_ADDR19 ALT5: GPIO2_IO16 ALT6: SDMA_EXT_EVENT0 ALT7: ALT8: USB_OTG1_PWR	VDDIO_GPIO0/NVCC_SD1	Signal only available on module without WLAN functionality.

LGA pad	ConnectCore 6UL pad	ConnectCore 6UL signal name	i.MX6UL pad name	Multiplexing	Power group	Comments
L20	LGA_L20	WLAN_SD1_DATA1	SD1_DATA1	ALT0: USDHC1_DATA1 ALT1: GPT2_CLK ALT2: SAI2_TX_BCLK ALT3: FLEXCAN1_RX ALT4: EIM_ADDR22 ALT5: GPIO2_IO19 ALT6: ALT7: ALT8: USB_OTG2_PWR	VDDIO_GPIO0/NVCC_SD1	Signal only available on module without WLAN functionality.
L21	LGA_L21	ENET1_RX_DATA0	ENET1_RX_DATA0	ALT0: ENET1_RDATA0 ALT1: UART4_RTS_B ALT2: PWM1_OUT ALT3: CSI_DATA16 ALT4: FLEXCAN1_TX ALT5: GPIO2_IO00 ALT6: KPP_ROW00 ALT7: ALT8: USDHC1_LCTL	NVCC_ENET	

LGA pad	ConnectCore 6UL pad	ConnectCore 6UL signal name	i.MX6UL pad name	Multiplexing	Power group	Comments
M1	LGA_M1	LCD_DATA9	LCD_DATA09	ALT0: LCDIF_DATA09 ALT1: SAI3_MCLK ALT2: ARM_PLATFORM_TRACE9 ALT3: CSI_DATA17 ALT4: EIM_DATA01 ALT5: GPIO3_IO14 ALT6: SRC_BT_CFG09 ALT7: ALT8: FLEXCAN1_RX	VCC_LCD	
M2	LGA_M2	NAND_DQS	NAND_DQS	ALT0: NAND_DQS ALT1: CSI_FIELD ALT2: QSPI_A_SS0_B ALT3: PWM5_OUT ALT4: EIM_WAIT ALT5: GPIO4_IO16 ALT6: SDMA_EXT_EVENT01 ALT7: ALT8: SPDIF_EXT_CLK	NVCC_NAND	

LGA pad	ConnectCore 6UL pad	ConnectCore 6UL signal name	i.MX6UL pad name	Multiplexing	Power group	Comments
M3	LGA_M3	NAND_DATA3	NAND_DATA03	ALT0: NAND_DATA03 ALT1: USDHC2_DATA3 ALT2: QSPI_B_DATA01 ALT3: KPP_COL02 ALT4: EIM_AD11 ALT5: GPIO4_IO05 ALT6: ALT7: ALT8: ECSPi4_SS3	NVCC_NAND	Leave this line floating if you want to use the on-module NAND
M19	LGA_M19	WLAN_SD1_DATA0	SD1_DATA0	ALT0: USDHC1_DATA0 ALT1: GPT2_COMPARE3 ALT2: SAI2_TX_SYNC ALT3: FLEXCAN1_TX ALT4: EIM_ADDR21 ALT5: GPIO2_IO18 ALT6: ALT7: ALT8: USB_OTG1_ID	VDDIO_GPI00/NVCC_SD1	Signal only available on module without WLAN functionality.

LGA pad	ConnectCore 6UL pad	ConnectCore 6UL signal name	i.MX6UL pad name	Multiplexing	Power group	Comments
M20	LGA_M20	WLAN_SD1_DATA3	SD1_DATA3	ALT0: USDHC1_DATA3 ALT1: GPT2_CAPTURE2 ALT2: SAI2_TX_DATA ALT3: FLEXCAN2_RX ALT4: EIM_ADDR24 ALT5: GPIO2_IO21 ALT6: CCM_CLKO2 ALT7: ALT8: USB_OTG2_ID	VDDIO_GPIO0/NVCC_SD1	Signal only available on module without WLAN functionality.
M21	LGA_M21	UART2_RTS#	UART2_RTS_B	ALT0: UART2_RTS_B ALT1: ENET1_COL ALT2: FLEXCAN2_RX ALT3: CSI_DATA09 ALT4: GPT1_COMPARE3 ALT5: GPIO1_IO23 ALT6: ALT7: SJC_FAIL ALT8: ECSPI3_MISO	NVCC_UART	
N1	LGA_N1	VCC_ENET	-		VCC_ENET	Power line (expected 3.3 V)

LGA pad	ConnectCore 6UL pad	ConnectCore 6UL signal name	i.MX6UL pad name	Multiplexing	Power group	Comments
N2	LGA_N2	NAND_DATA5	NAND_DATA05	ALT0: NAND_DATA05 ALT1: USDHC2_DATA5 ALT2: QSPI_B_DATA03 ALT3: ECSPI4_MOSI ALT4: EIM_AD13 ALT5: GPIO4_IO07 ALT6: ALT7: ALT8: UART2_RX	NVCC_NAND	Leave this line floating if you want to use the on-module NAND
N3	LGA_N3	GND	-		-	
N19	LGA_N19	LCD_DATA22	LCD_DATA22	ALT0: LCDIF_DATA22 ALT1: MQS_RIGHT ALT2: ECSPI1_MOSI ALT3: CSI_DATA14 ALT4: EIM_DATA14 ALT5: GPIO3_IO27 ALT6: SRC_BT_CFG30 ALT7: ALT8: USDHC2_DATA2	NVCC_LCD	

LGA pad	ConnectCore 6UL pad	ConnectCore 6UL signal name	i.MX6UL pad name	Multiplexing	Power group	Comments
N20	LGA_N20	LCD_DATA23	LCD_DATA23	ALT0: LCDIF_DATA23 ALT1: MQS_LEFT ALT2: ECSP11_MISO ALT3: CSI_DATA15 ALT4: EIM_DATA15 ALT5: GPIO3_IO28 ALT6: SRC_BT_CFG31 ALT7: ALT8: USDHC2_DATA3	NVCC_LCD	
N21	LGA_N21	UART2_CTS#	UART2_CTS_B	ALT0: UART2_CTS_B ALT1: ENET1_CRS ALT2: FLEXCAN2_TX ALT3: CSI_DATA08 ALT4: GPT1_COMPARE2 ALT5: GPIO1_IO22 ALT6: ALT7: SJC_DE_B ALT8: ECSP13_MOSI	NVCC_UART	
P1	LGA_P1	POR_B	-		VDDIO	Recommendation: Leave this pin floating
P2	LGA_P2	3V3_EXT	-		3V3_EXT	
P3	LGA_P3	GND	-		-	

LGA pad	ConnectCore 6UL pad	ConnectCore 6UL signal name	i.MX6UL pad name	Multiplexing	Power group	Comments
P19	LGA_P19	UART3_CTS#	UART3_CTS_B	ALT0: UART3_CTS_B ALT1: ENET2_RX_CLK ALT2: FLEXCAN1_TX ALT3: CSI_DATA10 ALT4: ENET1_1588_EVENT1_IN ALT5: GPIO1_IO26 ALT6: ALT7: ALT8: EPIT2_OUT	NVCC_UART	
P20	LGA_P20	UART3_RTS#	UART3_RTS_B	ALT0: UART3_RTS_B ALT1: ENET2_TX_ER ALT2: FLEXCAN1_RX ALT3: CSI_DATA11 ALT4: ENET1_1588_EVENT1_OUT ALT5: GPIO1_IO27 ALT6: ALT7: ALT8: WDOG1_WDOG_B	NVCC_UART	
P21	LGA_P21	GND	-		-	

LGA pad	ConnectCore 6UL pad	ConnectCore 6UL signal name	i.MX6UL pad name	Multiplexing	Power group	Comments
R1	LGA_R1	CSI_MCLK	CSI_MCLK	ALT0: CSI_MCLK ALT1: USDHC2_CD_B ALT2: NAND_CE2_B ALT3: I2C1_SDA ALT4: EIM_CS0_B ALT5: GPIO4_IO17 ALT6: SNVS_HP_VIO_5_CTL ALT7: ALT8: UART6_TX	NVCC_CSI	
R2	LGA_R2	NAND_DATA6	NAND_DATA06	ALT0: NAND_DATA06 ALT1: USDHC2_DATA6 ALT2: SAI2_RX_BCLK ALT3: ECSPI4_MISO ALT4: EIM_AD14 ALT5: GPIO4_IO08 ALT6: ALT7: ALT8: UART2_CTS_B	NVCC_NAND	Leave this line floating if you want to use the on-module NAND
R3	LGA_R3	GND	-		-	

LGA pad	ConnectCore 6UL pad	ConnectCore 6UL signal name	i.MX6UL pad name	Multiplexing	Power group	Comments
R19	LGA_R19	UART3_RX	UART3_RX_DATA	ALT0: UART3_RX ALT1: ENET2_RDATA03 ALT2: SIM2_PORT0_PD ALT3: CSI_DATA00 ALT4: UART2_RTS_B ALT5: GPIO1_IO25 ALT6: ALT7: ALT8: EPIT1_OUT	NVCC_UART	
R20	LGA_R20	UART3_TX	UART3_TX_DATA	ALT0: UART3_TX ALT1: ENET2_RDATA02 ALT2: SIM1_PORT0_PD ALT3: CSI_DATA01 ALT4: UART2_CTS_B ALT5: GPIO1_IO24 ALT6: ALT7: SJC_JTAG_ACT ALT8: USB_OTG1_ID	NVCC_UART	

LGA pad	ConnectCore 6UL pad	ConnectCore 6UL signal name	i.MX6UL pad name	Multiplexing	Power group	Comments
R21	LGA_R21	UART2_RX	UART2_RX_DATA	ALT0: UART2_RX ALT1: ENET1_TDATA03 ALT2: I2C4_SDA ALT3: CSI_DATA07 ALT4: GPT1_CAPTURE2 ALT5: GPIO1_IO21 ALT6: ALT7: SJC_DONE ALT8: ECSPI3_SCLK	NVCC_UART	
T1	LGA_T1	CSI_PIXCLK	CSI_PIXCLK	ALT0: CSI_PIXCLK ALT1: USDHC2_WP ALT2: NAND_CE3_B ALT3: I2C1_SCL ALT4: EIM_OE ALT5: GPIO4_IO18 ALT6: SNVS_HP_VIO_5 ALT7: ALT8: UART6_RX	NVCC_CSI	
T2	LGA_T2	-	-		-	
T3	LGA_T3	-	-		-	
T19	LGA_T19	(VDD_SNVS_IN) GPIO5_8	SNVS_TAMPER8	ALT5: GPIO05_IO08	VDD_SNVS_IN	
T20	LGA_T20	-	-	-		

LGA pad	ConnectCore 6UL pad	ConnectCore 6UL signal name	i.MX6UL pad name	Multiplexing	Power group	Comments
T21	LGA_T21	UART2_TX	UART2_TX_DATA	ALT0: UART2_TX ALT1: ENET1_TDATA02 ALT2: I2C4_SCL ALT3: CSI_DATA06 ALT4: GPT1_CAPTURE1 ALT5: GPIO1_IO20 ALT6: ALT7: ALT8: ECSPI3_SS0	NVCC_UART	
U1	LGA_U1	CSI_DATA1	CSI_DATA01	ALT0: CSI_DATA03 ALT1: USDHC2_DATA1 ALT2: SIM1_PORT1_SVEN ALT3: ECSPI2_SS0 ALT4: EIM_AD01 ALT5: GPIO4_IO22 ALT6: SAI1_MCLK ALT7: ALT8: UART5_RX	NVCC_CSI	
U2	LGA_U2	-	-		-	
U3	LGA_U3	-	-		-	

LGA pad	ConnectCore 6UL pad	ConnectCore 6UL signal name	i.MX6UL pad name	Multiplexing	Power group	Comments
U19	LGA_U19	GPIO9	GPIO1_IO09	ALT0: PWM2_OUT ALT1: WDOG1_WDOG_ANY ALT2: SPDIF_IN ALT3: CSI_HSYNC ALT4: USDHC2_RESET_B ALT5: GPIO1_IO09 ALT6: USDHC1_RESET_B ALT7: ALT8: UART5_CTS_B	NVCC_GPIO	
U20	LGA_U20	LCD_DATA13	LCD_DATA13	ALT0: LCDIF_DATA13 ALT1: SAI3_TX_BCLK ALT2: ALT3: CSI_DATA21 ALT4: EIM_DATA05 ALT5: GPIO3_IO18 ALT6: SRC_BT_CFG13 ALT7: ALT8: USDHC2_RESET_B	NVCC_LCD	

LGA pad	ConnectCore 6UL pad	ConnectCore 6UL signal name	i.MX6UL pad name	Multiplexing	Power group	Comments
U21	LGA_U21	JTAG_nTRST	JTAG_TRST_B	ALT0: SJC_TRSTB ALT1: GPT2_COMPARE3 ALT2: SAI2_TX_DATA ALT3: ALT4: PWM8_OUT ALT5: GPIO1_IO15 ALT6: ANATOP_24M_OUT ALT7: ALT8: CAAM_RNG_OSC_OBS	NVCC_GPIO	
V1	LGA_V1	CSI_HSYNC	CSI_HSYNC	ALT0: CSI_HSYNC ALT1: USDHC2_CMD ALT2: SIM1_PORT1_PD ALT3: I2C2_SCL ALT4: EIM_LBA_B ALT5: GPIO4_IO20 ALT6: PWM8_OUT ALT7: ALT8: UART6_CTS_B	NVCC_CSI	
V2	LGA_V2	GND	-		-	
V3	LGA_V3	BOOT_MODE0	BOOT_MODE0		VDD_SNVS_IN	100K pull-down resistor
V4	LGA_V4	GND	-		-	
V5	LGA_V5	(VDD_SNVS_IN) GPIO5_2	SNVS_TAMPER2	ALT5: GPIO05_IO02	VDD_SNVS_IN	

LGA pad	ConnectCore 6UL pad	ConnectCore 6UL signal name	i.MX6UL pad name	Multiplexing	Power group	Comments
V6	LGA_V6	GND	-		-	
V7	LGA_V7	LCD_DATA10	LCD_DATA10	ALT0: LCDIF_DATA10 ALT1: SAI3_RX_SYNC ALT2: ALT3: CSI_DATA18 ALT4: EIM_DATA02 ALT5: GPIO3_IO15 ALT6: SRC_BT_CFG10 ALT7: ALT8: FLEXCAN2_TX	NVCC_LCD	
V8	LGA_V8	LCD_DATA12	LCD_DATA12	ALT0: LCDIF_DATA12 ALT1: SAI3_TX_SYNC ALT2: ALT3: CSI_DATA20 ALT4: EIM_DATA04 ALT5: GPIO3_IO17 ALT6: SRC_BT_CFG12 ALT7: ALT8: ECSPI1_RDY	NVCC_LCD	

LGA pad	ConnectCore 6UL pad	ConnectCore 6UL signal name	i.MX6UL pad name	Multiplexing	Power group	Comments
V9	LGA_V9	LCD_DATA15	LCD_DATA15	ALT0: LCDIF_DATA15 ALT1: SAI3_TX_DATA ALT2: ALT3: CSI_DATA23 ALT4: EIM_DATA07 ALT5: GPIO3_IO20 ALT6: SRC_BT_CFG15 ALT7: ALT8: USDHC2_DATA5	NVCC_LCD	
V10	LGA_V10	LCD_DATA18	LCD_DATA18	ALT0: LCDIF_DATA18 ALT1: PWM5_OUT ALT2: CA7_MX6UL_EVENTO ALT3: CSI_DATA10 ALT4: EIM_DATA10 ALT5: GPIO3_IO23 ALT6: SRC_BT_CFG26 ALT7: ALT8: USDHC2_CMD	NVCC_LCD	
V11	LGA_V11	GND	-		-	

LGA pad	ConnectCore 6UL pad	ConnectCore 6UL signal name	i.MX6UL pad name	Multiplexing	Power group	Comments
V12	LGA_V12	LCD_DATA20	LCD_DATA20	ALT0: LCDIF_DATA20 ALT1: UART8_TX ALT2: ECSP1_SCLK ALT3: CSI_DATA12 ALT4: EIM_DATA12 ALT5: GPIO3_IO25 ALT6: SRC_BT_CFG28 ALT7: ALT8: USHC2_DATA0	NVCC_LCD	
V13	LGA_V13	LCD_DATA11	LCD_DATA11	ALT0: LCDIF_DATA11 ALT1: SAI3_RX_BCLK ALT2: ALT3: CSI_DATA19 ALT4: EIM_DATA03 ALT5: GPIO3_IO16 ALT6: SRC_BT_CFG11 ALT7: ALT8: FLEXCAN2_RX	NVCC_LCD	
V14	LGA_V14	(VDD_SNVS_IN) GPIO5_1	SNVS_TAMPER1	ALT5: GPIO05_IO01	VDD_SNVS_IN	
V15	LGA_V15	(VDD_SNVS_IN) GPIO5_3	SNVS_TAMPER3	ALT5: GPIO05_IO03		
V16	LGA_V16	GND	-		-	

LGA pad	ConnectCore 6UL pad	ConnectCore 6UL signal name	i.MX6UL pad name	Multiplexing	Power group	Comments
V17	LGA_V17	ENET2_TX_EN	ENET2_TX_EN	ALT0: ENET2_TX_EN ALT1: UART8_RX ALT2: SIM2_PORT0_CLK ALT3: ECSPI4_MOSI ALT4: EIM_ACLK_FREERUN ALT5: GPIO2_IO13 ALT6: KPP_COL06 ALT7: ALT8: USB_OTG2_OC	NVCC_ENET	
V18	LGA_V18	ENET2_TX_CLK	ENET2_TX_CLK	ALT0: ENET2_TX_CLK ALT1: UART8_CTS_B ALT2: SIM2_PORT0_RTS_B ALT3: ECSPI4_MISO ALT4: XTALOSC_REF_CLK2 ALT5: GPIO2_IO14 ALT6: KPP_ROW07 ALT7: ALT8: USB_OTG2_ID	NVCC_ENET	

LGA pad	ConnectCore 6UL pad	ConnectCore 6UL signal name	i.MX6UL pad name	Multiplexing	Power group	Comments
V19	LGA_V19	ENET2_RX_ER	ENET2_RX_ER	ALT0: ENET2_RX_ER ALT1: UART8_RTS_B ALT2: SIM2_PORT0_SVEN ALT3: ECSPI4_SS0 ALT4: EIM_ADDR25 ALT5: GPIO2_IO15 ALT6: KPP_COL07 ALT7: ALT8: WDOG1_WDOG_ANY	NVCC_ENET	
V20	LGA_V20	ENET2_RX_EN	ENET2_RX_EN	ALT0: ENET2_RX_EN ALT1: UART7_TX ALT2: SIM1_PORT0_RST_B ALT3: I2C4_SCL ALT4: EIM_ADDR26 ALT5: GPIO2_IO10 ALT6: KPP_ROW05 ALT7: ALT8: ENET1_REF_CLK_25M	NVCC_ENET	

LGA pad	ConnectCore 6UL pad	ConnectCore 6UL signal name	i.MX6UL pad name	Multiplexing	Power group	Comments
V21	LGA_V21	JTAG_TDI	JTAG_TDI	ALT0: SJC_TDI ALT1: GPT2_COMPARE1 ALT2: SAI2_TX_BCLK ALT3: ALT4: PWM6_OUT ALT5: GPIO1_IO13 ALT6: MQS_LEFT ALT7: ALT8: SIM1_POWER_FAIL	NVCC_GPIO	
W1	LGA_W1	GPIO1_5	GPIO1_IO5	ALT0: ENET2_REF_CLK2 ALT1: PWM4_OUT ALT2: USB_OTG2_ID ALT3: CSI_FIELD ALT4: USDHC1_VSELECT ALT5: GPIO1_IO05 ALT6: ENET2_1588_EVENT0_OUT ALT7: ALT8: UART5_RX	NVCC_GPIO	

LGA pad	ConnectCore 6UL pad	ConnectCore 6UL signal name	i.MX6UL pad name	Multiplexing	Power group	Comments
W2	LGA_W2	CSI_DATA4	CSI_DATA04	ALT0: CSI_DATA06 ALT1: USDHC2_DATA4 ALT2: SIM2_PORT1_CLK ALT3: ECSP11_SCLK ALT4: EIM_AD04 ALT5: GPIO4_IO25 ALT6: SAI1_TX_SYNC ALT7: ALT8: USDHC1_WP	NVCC_CSI	
W3	LGA_W3	CSI_DATA6	CSI_DATA06	ALT0: CSI_DATA08 ALT1: USDHC2_DATA6 ALT2: SIM2_PORT1_SVEN ALT3: ECSP11_MOSI ALT4: EIM_AD06 ALT5: GPIO4_IO27 ALT6: SAI1_RX_DATA ALT7: ALT8: USDHC1_RESET_B	NVCC_CSI	
W4	LGA_W4	-	-		-	

LGA pad	ConnectCore 6UL pad	ConnectCore 6UL signal name	i.MX6UL pad name	Multiplexing	Power group	Comments
W5	LGA_W5	CSI_DATA7	CSI_DATA07	ALT0: CSI_DATA09 ALT1: USDHC2_DATA7 ALT2: SIM2_PORT1_TRXD ALT3: ECSP11_MISO ALT4: EIM_AD07 ALT5: GPIO4_IO28 ALT6: SAI1_TX_DATA ALT7: ALT8: USDHC1_VSELECT	NVCC_CSI	
W6	LGA_W6	GND	-		-	
W7	LGA_W7	VDD_SNV5_IN	-		VDD_SNV5_IN	Power line
W8	LGA_W8	PWR_ON	-	PWR_ON	VCC_MCA	Recommendation: Leave this pin floating
W9	LGA_W9	-	-	-		
W10	LGA_W10	LCD_DATA16	-	ALT0: LCDIF_DATA16 ALT1: UART7_TX ALT2: ALT3: CSI_DATA01 ALT4: EIM_DATA08 ALT5: GPIO3_IO21 ALT6: SRC_BT_CFG24 ALT7: ALT8: USDHC2_DATA6	NVCC_LCD	

LGA pad	ConnectCore 6UL pad	ConnectCore 6UL signal name	i.MX6UL pad name	Multiplexing	Power group	Comments
W11	LGA_W11	GND	-		-	
W12	LGA_W12	GND	-		-	
W13	LGA_W13	(VDD_SNV5_IN) GPIO5_7	SNVS_ TAMPER7	ALT5: GPIO05_IO07	VDD_SNV5_IN	
W14	LGA_W14	ONOFF			VDD_SNV5_IN	Recommendation: Leave this pin floating
W15	LGA_W15	(VDD_SNV5_IN) GPIO5_6		ALT5: GPIO05_IO06	VDD_SNV5_IN	
W16	LGA_W16	GND			-	
W17	LGA_W17	ENET2_RX_DATA0		ALT0: ENET2_ RDATA00 ALT1: UART6_TX ALT2: SIM1_PORT0_ TRXD ALT3: I2C3_SCL ALT4: ENET1_MDIO ALT5: GPIO2_IO08 ALT6: KPP_ROW04 ALT7: ALT8: USB_OTG1_ PWR	NVCC_ENET	

LGA pad	ConnectCore 6UL pad	ConnectCore 6UL signal name	i.MX6UL pad name	Multiplexing	Power group	Comments
W18	LGA_W18	ENET2_TX_DATA0		ALT0: ENET2_TDATA00 ALT1: UART7_RX ALT2: SIM1_PORT0_SVEN ALT3: I2C4_SDA ALT4: EIM_EB2_B ALT5: GPIO2_IO11 ALT6: KPP_COL05 ALT7: ALT8: ANATOP_24M_OUT	NVCC_ENET	
W19	LGA_W19	ENET2_RX_DATA1		ALT0: ENET2_RDATA01 ALT1: UART6_RX ALT2: SIM1_PORT0_CLK ALT3: I2C3_SDA ALT4: ENET1_MDC ALT5: GPIO2_IO09 ALT6: KPP_COL04 ALT7: ALT8: USB_OTG1_OC	NVCC_ENET	

LGA pad	ConnectCore 6UL pad	ConnectCore 6UL signal name	i.MX6UL pad name	Multiplexing	Power group	Comments
W20	LGA_W20	ENET2_TX_DATA1		ALT0: ENET2_TDATA01 ALT1: UART8_TX ALT2: SIM2_PORT0_TRXD ALT3: ECSPI4_SCLK ALT4: EIM_EB3_B ALT5: GPIO2_IO12 ALT6: KPP_ROW06 ALT7: ALT8: USB_OTG2_PWR	NVCC_ENET	
W21	LGA_W21	JTAG_TCK		ALT0: SJC_TCK ALT1: GPT2_COMPARE2 ALT2: SAI2_RX_DATA ALT3: ALT4: PWM7_OUT ALT5: GPIO1_IO14 ALT6: OSC32K_32K_OUT ALT7: ALT8: SIM2_POWER_FAIL	NVCC_GPIO	
Y1	LGA_Y1	BOOT_MODE1			VDD_SNV5_IN	

LGA pad	ConnectCore 6UL pad	ConnectCore 6UL signal name	i.MX6UL pad name	Multiplexing	Power group	Comments
Y2	LGA_Y2	CSI_DATA5		ALT0: CSI_DATA07 ALT1: USDHC2_DATA5 ALT2: SIM2_PORT1_RST_B ALT3: ECSP11_SS0 ALT4: EIM_AD05 ALT5: GPIO4_IO26 ALT6: SAI1_TX_BCLK ALT7: ALT8: USDHC1_CD_B	NVCC_CSI	
Y3	LGA_Y3	-		-		
Y4	LGA_Y4	(VDD_SNV5_IN) GPIO5_5		ALT5: GPIO05_IO05	VDD_SNV5_IN	
Y5	LGA_Y5	-		-	-	
Y6	LGA_Y6	-		-	-	
Y7	LGA_Y7	I2C1_SCL/UART4_TX		ALT0: UART4_TX ALT1: ENET2_TDATA02 ALT2: I2C1_SCL ALT3: CSI_DATA12 ALT4: CSU_CSU_ALARM_AUT02 ALT5: GPIO1_IO28 ALT6: ALT7: ALT8: ECSP12_SCLK	NVCC_UART	

LGA pad	ConnectCore 6UL pad	ConnectCore 6UL signal name	i.MX6UL pad name	Multiplexing	Power group	Comments
Y8	LGA_Y8	I2C1_SDA/UART4_RX		ALT0: UART4_RX ALT1: ENET2_TDATA03 ALT2: I2C1_SDA ALT3: CSI_DATA13 ALT4: CSU_CSU_ALARM_AUT01 ALT5: GPIO1_IO29 ALT6: ALT7: ALT8: ECSPI2_SS0	NVCC_UART	
Y9	LGA_Y9	LCD_DATA21		ALT0: LCDIF_DATA21 ALT1: UART8_RX ALT2: ECSPI1_SS0 ALT3: CSI_DATA13 ALT4: EIM_DATA13 ALT5: GPIO3_IO26 ALT6: SRC_BT_CFG29 ALT7: ALT8: USDHC2_DATA1	NVCC_LCD	
Y10	LGA_Y10	GND			-	
Y11	LGA_Y11	USB_OTG1_VBUS			USB_VBUS	Power line

LGA pad	ConnectCore 6UL pad	ConnectCore 6UL signal name	i.MX6UL pad name	Multiplexing	Power group	Comments
Y12	LGA_Y12	LCD_DATA14		ALT0: LCDIF_DATA14 ALT1: SAI3_RX_DATA ALT2: ALT3: CSI_DATA22 ALT4: EIM_DATA06 ALT5: GPIO3_IO19 ALT6: SRC_BT_CFG14 ALT7: ALT8: USDHC2_DATA4	NVCC_LCD	
Y13	LGA_Y13	GPIO2		ALT0: I2C1_SCL ALT1: GPT1_COMPARE2 ALT2: USB_OTG2_PWR ALT3: ENET1_REF_CLK_25M ALT4: USDHC1_WP ALT5: GPIO1_IO02 ALT6: SDMA_EXT_EVENT00 ALT7: ALT8: UART1_TX	NVCC_GPIO	

LGA pad	ConnectCore 6UL pad	ConnectCore 6UL signal name	i.MX6UL pad name	Multiplexing	Power group	Comments
Y14	LGA_Y14	GPIO3		ALT0: I2C1_SDA ALT1: GPT1_COMPARE3 ALT2: USB_OTG2_OC ALT3: OSC32K_32K_OUT ALT4: USDHC1_CD_B ALT5: GPIO1_IO03 ALT6: CCM_DI0_EXT_CLK ALT7: SRC_TESTER_ACK ALT8: UART1_RX	NVCC_GPIO	
Y15	LGA_Y15	USB_OTG2_VBUS			USB_VBUS	Power line
Y16	LGA_Y16	USB_OTG2_VBUS			USB_VBUS	Power line
Y17	LGA_Y17	LCD_DATA19		ALT0: LCDIF_DATA19 ALT1: PWM6_OUT ALT2: WDOG1_WDOG_ANY ALT3: CSI_DATA11 ALT4: EIM_DATA11 ALT5: GPIO3_IO24 ALT6: SRC_BT_CFG27 ALT7: ALT8: USDHC2_CLK	NVCC_LCD	
Y18	LGA_Y18	nUSB_OTG1_CHD				

LGA pad	ConnectCore 6UL pad	ConnectCore 6UL signal name	i.MX6UL pad name	Multiplexing	Power group	Comments
Y19	LGA_Y19	GPIO8		ALT0: PWM1_OUT ALT1: WDOG1_WDOG_B ALT2: SPDIF_OUT ALT3: CSI_VSYNC ALT4: USDHC2_VSELECT ALT5: GPIO1_IO08 ALT6: CCM_PMIC_READY ALT7: ALT8: UART5_RTS_B	NVCC_GPIO	
Y20	LGA_Y20	LCD_DATA17		ALT0: LCDIF_DATA17 ALT1: UART7_RX ALT2: ALT3: CSI_DATA00 ALT4: EIM_DATA09 ALT5: GPIO3_IO22 ALT6: SRC_BT_CFG25 ALT7: ALT8: USDHC2_DATA7	NVCC_LCD	

LGA pad	ConnectCore 6UL pad	ConnectCore 6UL signal name	i.MX6UL pad name	Multiplexing	Power group	Comments
Y21	LGA_Y21	JTAG_TDO		ALT0: SJC_TDO ALT1: GPT2_CAPTURE2 ALT2: SAI2_TX_SYNC ALT3: CCM_CLKO2 ALT4: CCM_STOP ALT5: GPIO1_IO12 ALT6: MQS_RIGHT ALT7: ALT8: EPIT2_OUT	NVCC_GPIO	
AA1	LGA_AA1	GND			-	
AA2	LGA_AA2	CSI_DATA0		ALT0: CSI_DATA02 ALT1: USDHC2_DATA0 ALT2: SIM1_PORT1_RST_B ALT3: ECSPI2_SCLK ALT4: EIM_AD00 ALT5: GPIO4_IO21 ALT6: SRC_INT_BOOT ALT7: ALT8: UART5_TX	NVCC_CSI	

LGA pad	ConnectCore 6UL pad	ConnectCore 6UL signal name	i.MX6UL pad name	Multiplexing	Power group	Comments
AA3	LGA_AA3	CSI_VSYNC		ALT0: CSI_VSYNC ALT1: USDHC2_CLK ALT2: SIM1_PORT1_CLK ALT3: I2C2_SDA ALT4: EIM_RW ALT5: GPIO4_IO19 ALT6: PWM7_OUT ALT7: ALT8: UART6_RTS_B	NVCC_CSI	
AA4	LGA_AA4	CSI_DATA2		ALT0: CSI_DATA04 ALT1: USDHC2_DATA2 ALT2: SIM1_PORT1_TRXD ALT3: ECSP12_MOSI ALT4: EIM_AD02 ALT5: GPIO4_IO23 ALT6: SAI1_RX_SYNC ALT7: ALT8: UART5_RTS_B	NVCC_CSI	

LGA pad	ConnectCore 6UL pad	ConnectCore 6UL signal name	i.MX6UL pad name	Multiplexing	Power group	Comments
AA5	LGA_AA5	CSI_DATA3		ALT0: CSI_DATA05 ALT1: USDHC2_DATA3 ALT2: SIM2_PORT1_PD ALT3: ECSPI2_MISO ALT4: EIM_AD03 ALT5: GPIO4_IO24 ALT6: SAI1_RX_BCLK ALT7: ALT8: UART5_CTS_B	NVCC_CSI	
AA6	LGA_AA6	UART5_TX		ALT0: UART5_TX ALT1: ENET2_CRS ALT2: I2C2_SCL ALT3: CSI_DATA14 ALT4: CSU_CSU_ALARM_AUT00 ALT5: GPIO1_IO30 ALT6: ALT7: ALT8: ECSPI2_MOSI	NVCC_UART	

LGA pad	ConnectCore 6UL pad	ConnectCore 6UL signal name	i.MX6UL pad name	Multiplexing	Power group	Comments
AA7	LGA_AA7	UART5_RX		ALT0: UART5_RX ALT1: ENET2_COL ALT2: I2C2_SDA ALT3: CSI_DATA15 ALT4: CSU_CSU_INT_DEB ALT5: GPIO1_IO31 ALT6: ALT7: ALT8: ECSPI2_MISO	NVCC_UART	
AA8	LGA_AA8	USB_OTG1_P				USB differential data line
AA9	LGA_AA9	USB_OTG1_N				USB differential data line
AA10	LGA_AA10	GND			-	
AA11	LGA_AA11	USB_OTG1_VBUS			USB_VBUS	Power line
AA12	LGA_AA12	GPIO4		ALT0: ENET1_REF_CLK1 ALT1: PWM3_OUT ALT2: USB_OTG1_PWR ALT3: ANATOP_24M_OUT ALT4: USDHC1_RESET_B ALT5: GPIO1_IO04 ALT6: ENET2_1588_EVENT0_IN ALT7: ALT8: UART5_TX	NVCC_GPIO	

LGA pad	ConnectCore 6UL pad	ConnectCore 6UL signal name	i.MX6UL pad name	Multiplexing	Power group	Comments
AA13	LGA_AA13	GPIO0		ALT0: I2C2_SCL ALT1: GPT1_CAPTURE1 ALT2: USB_OTG1_ID ALT3: ENET1_REF_CLK1 ALT4: MQS_RIGHT ALT5: GPIO1_IO00 ALT6: ENET1_1588_EVENT0_IN ALT7: SRC_SYSTEM_RESET ALT8: WDOG3_WDOG_B	NVCC_GPIO	
AA14	LGA_AA14	GPIO1		ALT0: I2C2_SDA ALT1: GPT1_COMPARE1 ALT2: USB_OTG1_OC ALT3: ENET2_REF_CLK2 ALT4: MQS_LEFT ALT5: GPIO1_IO01 ALT6: ENET1_1588_EVENT0_OUT ALT7: SRC_EARLY_RESET ALT8: WDOG1_WDOG_B	NVCC_GPIO	

LGA pad	ConnectCore 6UL pad	ConnectCore 6UL signal name	i.MX6UL pad name	Multiplexing	Power group	Comments
AA15	LGA_AA15	JTAG_MOD		ALT0: SJC_MOD ALT1: GPT2_CLK ALT2: SPDIF_OUT ALT3: ENET1_REF_CLK_25M ALT4: CCM_PMIC_READY ALT5: GPIO1_IO10 ALT6: SDMA_EXT_EVENT00 ALT7: ALT8:	NVCC_GPIO	
AA16	LGA_AA16	JTAG_TMS		ALT0: SJC_TMS ALT1: GPT2_CAPTURE1 ALT2: SAI2_MCLK ALT3: CCM_CLKO1 ALT4: CCM_WAIT ALT5: GPIO1_IO11 ALT6: SDMA_EXT_EVENT01 ALT7: ALT8: EPIT1_OUT	NVCC_GPIO	
AA17	LGA_AA17	USB_OTG2_P				USB differential data line
AA18	LGA_AA18	USB_OTG2_N				USB differential data line

LGA pad	ConnectCore 6UL pad	ConnectCore 6UL signal name	i.MX6UL pad name	Multiplexing	Power group	Comments
AA19	LGA_AA19	GPIO7		ALT0: ENET1_MDC ALT1: ENET2_MDC ALT2: USB_OTG_HOST_MODE ALT3: CSI_PIXCLK ALT4: USDHC2_CD_B ALT5: GPIO1_IO07 ALT6: CCM_STOP ALT7: ALT8: UART1_RTS_B	NVCC_GPIO	
AA20	LGA_AA20	GPIO6		ALT0: ENET1_MDIO ALT1: ENET2_MDIO ALT2: USB_OTG_PWR_WAKE ALT3: CSI_MCLK ALT4: USDHC2_WP ALT5: GPIO1_IO06 ALT6: CCM_WAIT ALT7: CCM_REF_EN_B ALT8: UART1_CTS_B	NVCC_GPIO	
AA21	LGA_AA21	GND			-	

Module specifications

The following sections describe the specifications for the ConnectCore 6UL module.

Electrical specifications	116
Power consumption	116
Mechanical specifications	122
Environmental specifications	125
Socket options	125

Electrical specifications

The following tables detail the power supply voltages of the ConnectCore 6UL module.

With front-end LDO

Power domain		Min	Typ	Max	Unit
VPWR	In regulation	4.6	-	5.5	V
	In dropout operation	3.7	-	4.6	V
VSYS		4.3	4.4	4.55	V
VSYS2		2.8	-	4.5	V
VCC_LICELL		2.4	3	3.6	V
VCC_MCA		2.4	3	3.6	V

Without front-end LDO

Power domain	Min	Typ	Max	Unit
VPWR	0			V
VSYS	3.7	4.4	4.5	V
VSYS2	2.8	4.4	4.5	V
VCC_LICELL	2.4	3	3.6	V
VCC_MCA	2.4	3	3.6	V

Power consumption

This section contains data on the power consumption of the ConnectCore 6UL module using measurements from the following power domains:

- VSYS:** the input power rail of the module (PMIC input). Power consumption associated with other power domains that power carrier board peripherals (3V3_EXT and LDO4_1V8) will be discounted from the values since they are powering external circuitry. However, the VCC_ENET power domain (which is powered externally) as well as VCC_MCA (which is powering the on-module MCA) are included in the module power consumption. So, the global power consumption of the ConnectCore 6UL module is calculated as:

$$P_{CC6UL} = P_{SYS} + P_{VCC_MCA} + P_{VCC_ENET} - P_{3V3_EXT} - P_{LDO4_1V8}$$

- VCC_MCA:** input power rail of the on-module MCA. While this power consumption is part of the module, its input is different than the PMIC (VSYS) so it is measured separately. It's important

to note that the MCA power consumption is very stable in run-time and fluctuates very little from one use case to another. So, for this element, only three use cases are represented: suspend to RAM, power-off, and run-time.

Note These power consumption numbers should be considered guidelines only, never as fixed or absolute values. Actual values will depend entirely upon individual setup and system application.

Note The wireless tests were run with the device in test mode. Since in test mode the system is configured to work at 99% time transmitting, these values can be considered to be the highest power consumption associated with each wireless mode. In real wireless transmission, many modes and modulations may be used in a single connection depending on the environmental conditions, resulting in different power consumption numbers. See [Power consumption: Real wireless transmission](#).

Power consumption use cases

This section describes the use cases that were used to measure power consumption of the ConnectCore 6UL module.

Suspend

System in suspend-to-RAM mode. The power consumption in this operation mode will be evaluated when using and not using the PMIC Front-end LDO. See [Power supply](#) for more information about how to power up the ConnectCore 6UL module.



CAUTION! You can achieve minimum power consumption numbers by disabling both 3.3V power domains. However, in some applications it may not be possible to switch them off, depending on what they are powering.

Power-off

System in power-off with RTC enabled. RTC is running in the MCA. The power consumption in this operation mode will be also evaluated when using and not using the PMIC Front-end LDO.

IDLE

System up and running. Ethernet and wireless disabled.

Decoding video

System up and running with the following configuration:

- Ethernet and wireless disabled.
- Fusion7 parallel display connected to the system.

Includes two different use cases:

- Display connected in IDLE mode (without decoding video).
- CPU decoding video.

CPU stress

System up and running with the following configuration:

- One Ethernet interface up and linked. The other one disabled.
- USB connected to the system.
- Hanoi application running. (The Hanoi application stresses the CPU and put it at 100% work load.)

Wireless

In all other use cases, wireless was disabled in order to ease the power consumption calculation. This dedicated section describes the power consumption of the ConnectCore 6UL module when transmitting (in **test mode**) in different wireless modes on both 2.4 GHz and 5 GHz channels (see [Power consumption: Real wireless transmission](#)):

2.4 GHz:

- 99% time transmitting.
- Channel 6 (2437 MHz).

5 GHz:

- 99% time transmitting.
- Channel 120 (5600 MHz).

In the real wireless transmission scenario, the ConnectCore 6UL module is connected to an AP (transmitting and receiving):

- Ethernet disabled.
- 50MB file transmitted and received between the DUT and the AP.
- Connection in the 802.11g/n mode at 2.4 GHz (2437 MHz channel).
- In a real wireless transmission, modulation and bandwidth are configured automatically.

Wireless UART Bridge

Hardware setup

- ConnectCore 6UL module mounted on a SBC Express.
- UART4 connected to a host PC serial port (through a TTL-to-RS232 adapter).
- Console connected to the host PC.

Test case configuration

- Continuous traffic through the UART4, commanded through the Console port (stressing both UARTs):
 - Checks all bit rates below 115200.
 - Checks different parities and packet sizes.
- Wireless up and running:
 - 100 K file transmitted and received between the DUT and the AP, so there will be also reception through the wireless interface. The test is continuously sending the packages, so more than one transmission is executed every five seconds.
 - Connection in the 802.11g/n mode at 2.4 GHz (2437 MHz channel).
- I2C1 bus up and running (no specific actions taken on this interface).

The power consumption contribution of the serial buses, as the I2C or the UART, is negligible compared to the wireless or a high CPU load (such as decoding video or executing dedicated computational applications). See [Power consumption: Wireless-UART bridge](#).

Power consumption debugging

You can use the ConnectCore 6UL SBC Express to simplify the design and debugging of optimized power consumption for the ConnectCore 6UL module. Specific current measurement options have been added for measuring VSYS and VCC_MCA going to the ConnectCore 6UL module. To use the current measurement option on VSYS, depopulate R113 and populate J15. Connect a multimeter across J15 to measure VSYS current flowing to the module. You can apply a similar procedure to R114 and J16 to measure VCC_MCA current.

You can also use the ConnectCore 6UL SBC Express to test VSYS supplies below 4.5V, which are typically required for battery operation. In order to facilitate this mode, ground VPWR (R115 populated and R6 depopulated) and leave LDOG unconnected (depopulate C1 and U1). To connect the power connector J3 to VSYS, populate R116. In this configuration, the module must be supplied by a voltage between 4.5V and 3.7V. The lower limit of 3.7V is mandatory for maintaining a 3.3V output on the buck converters of the PMIC.

Note The 3.7V lower limit only applies to VSYS and not VSYS2 on a battery-operated design, since VSYS2 is supplying only buck converters with much lower output voltage. In this configuration, you can connect a battery directly to VSYS2 as long as you have a buck boost regulator for VSYS. While this mode of operation is supported by the ConnectCore 6UL module, the ConnectCore 6UL SBC Express does not provide options to test/evaluate it.

Global power consumption

The following tables list the global power consumption of the ConnectCore 6UL module when the system is under the use cases described below.

Suspend and power-off modes

	Suspend-to-RAM mode		Power-off mode	
	Front-end LDO used (VSYS = 4.4V)	Front-end LDO not used (VSYS = 3.8V)	Front-end LDO used (VSYS = 4.4V)	No Front-end LDO used (VSYS = 3.8V)
Whole module	17.8 mW	8.55 mW	1.65 mW*	1.32 mW*
MCA	12 uW		7.5 uW	

Note * See [Power supply](#) for detailed information about how to optimize the power consumption in low power modes.

Run-time modes

	Run-time			
	IDLE	Display connected (IDLE)	Decoding video	CPU stress
Whole module	0.635 W	0.649 W	0.868 W	0.840 W
MCA	20 mW			

Note These power consumption numbers should be considered guidelines only, never as fixed or absolute values. Actual values will depend entirely upon individual setup and system application.

Power consumption: Wireless power consumption increase

The following tables shows the power consumption increase of the ConnectCore 6UL module when transmitting in 2.4 GHz and 5 GHz modes:

2.4 GHz modes	Power (dBm)	Continuous Tx (99%)
11b 1 Mbps 20MHz	18	1.123 W
11b 11 Mbps 20MHz	18	1.086 W
11g 6 Mbps 20MHz	18	0.991 W
11g 54 Mbps 20MHz	18	0.783 W
11g/n MCS0 20MHz	18	0.976 W
11g/n MCS7 20MHz	15	0.643 W
11g/n MCS0 40MHz	17	0.932 W
11g/n MCS7 40MHz	15	0.552 W

5 GHz modes	Power (dBm)	Continuous Tx (99%)
11a 6 Mbps 20MHz	13	1.095 W
11a 54 Mbps 20MHz	11	0.801 W
11a/n MCS0 20MHz	13	1.083 W
11a/n MCS7 20MHz	10	0.743 W
11a/n MCS0 40MHz	12	1.052 W
11a/n MCS7 40MHz	9	0.636 W
11ac MCS0 20MHz	13	1.097 W
11ac MCS7 20MHz	10	0.712 W
11ac MCS8 20MHz	9	0.672 W

5 GHz modes	Power (dBm)	Continuous Tx (99%)
11ac MCS9 40MHz	7	0.540 W
11ac MCS9 80MHz	6	0.467 W

Note Continuous Rx

Continuously receiving data (continuous Rx) in test mode has almost no effect on the power consumption of the module. In real transmissions, there won't be a continuous reception use case because the system will be always transmitting some synchronization data when receiving, and the power consumption will be increased as observed in [Power consumption: Real wireless transmission](#) (but never as much as when transmitting).

Note These power consumption numbers should be considered guidelines only, never as fixed or absolute values. Actual values will depend entirely upon individual setup and system application.

Power consumption: Real wireless transmission

The following plot shows the power consumption of the ConnectCore 6UL VSYS power domain during a real wireless transmission:

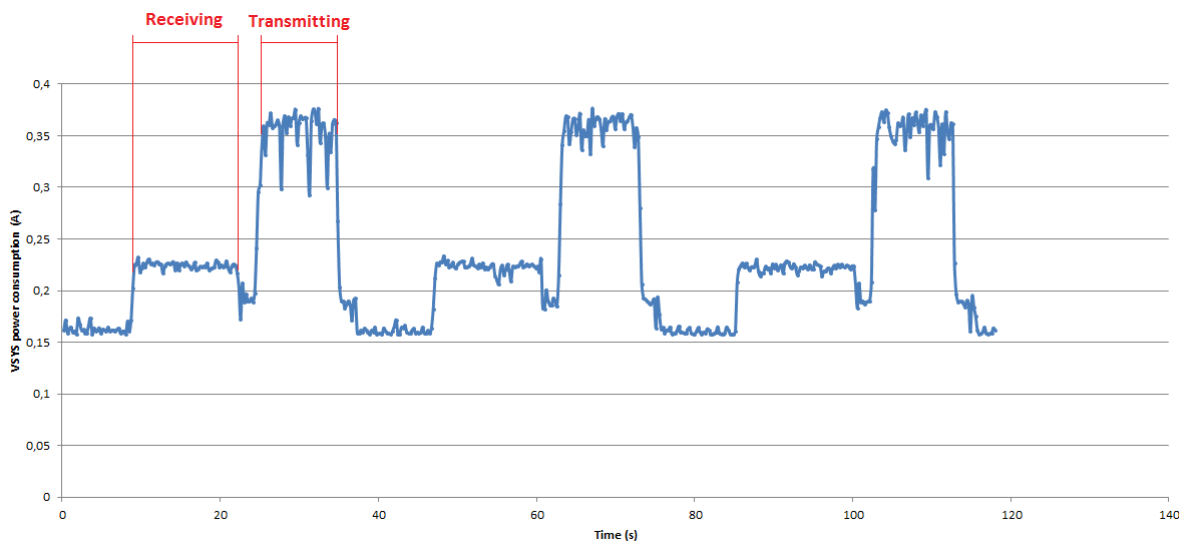

The power consumption increase of the real wireless transmission is calculated by taking the mean power consumption value of the transmission and receiver bursts:

	Power consumption increase
Transmission	0.849 W
Reception	0.279 W

As expected, the transmission power consumption is lower than the maximum observed in the tables above on the 802.11g/n mode (0.976 W in 11g/n MCS0 20MHz). **In a real wireless transmission, modulation and bandwidth are configured automatically.**

Note These power consumption numbers should be considered guidelines only, never as fixed or absolute values. Actual values will depend entirely upon individual setup and system application.

Power consumption: Wireless-UART bridge

The following table shows average power consumption of each operating mode:

	IDLE	UART	UART+Wireless
Module power consumption	0.3011 W	0.30589 W	0.524 W

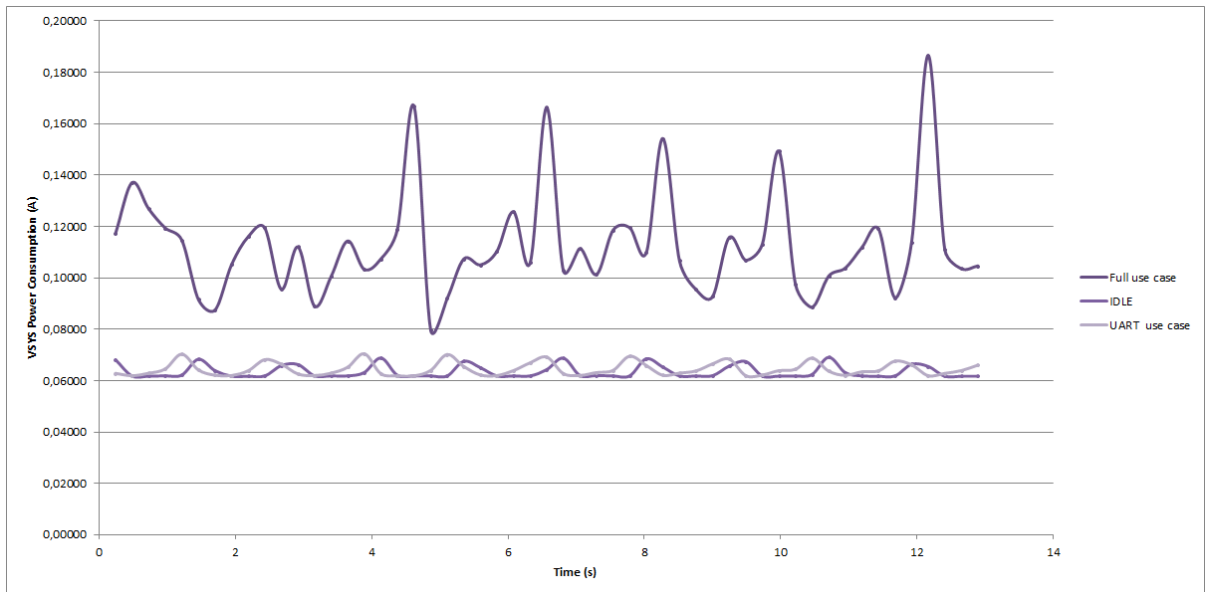

Note Average power consumption was calculated after approximately a minute of sampling data, but the plot shows power consumption over 13 seconds for a more detailed view of power consumption oscillations.

Note These power consumption numbers should be considered guidelines only, never as fixed or absolute values. Actual values will depend entirely upon individual setup and system application.

Mechanical specifications

This section provides mechanical dimensions and host PCB footprint guidance for the Digi SMTplus™ (patent-pending) form factor of the ConnectCore 6UL module.

Dimensions

Note that all dimensions are in millimeters.

Module specifications

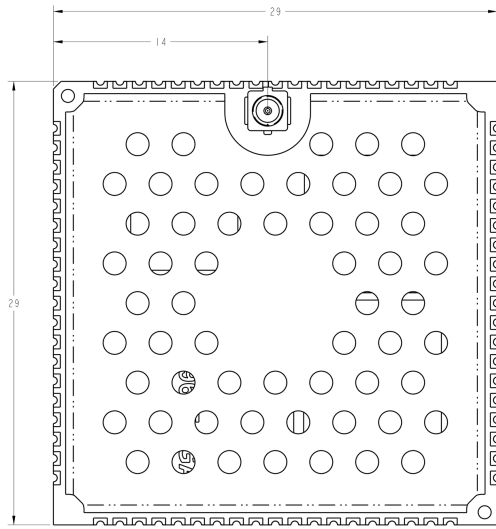

TOP

Mechanical specifications

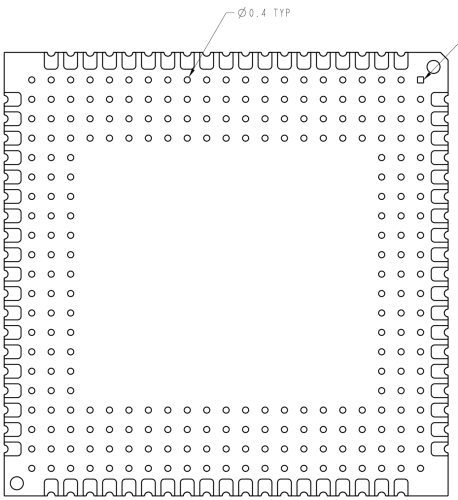

BOTTOM



Host PCB footprint

Digi SMTplus™ LGA mounting

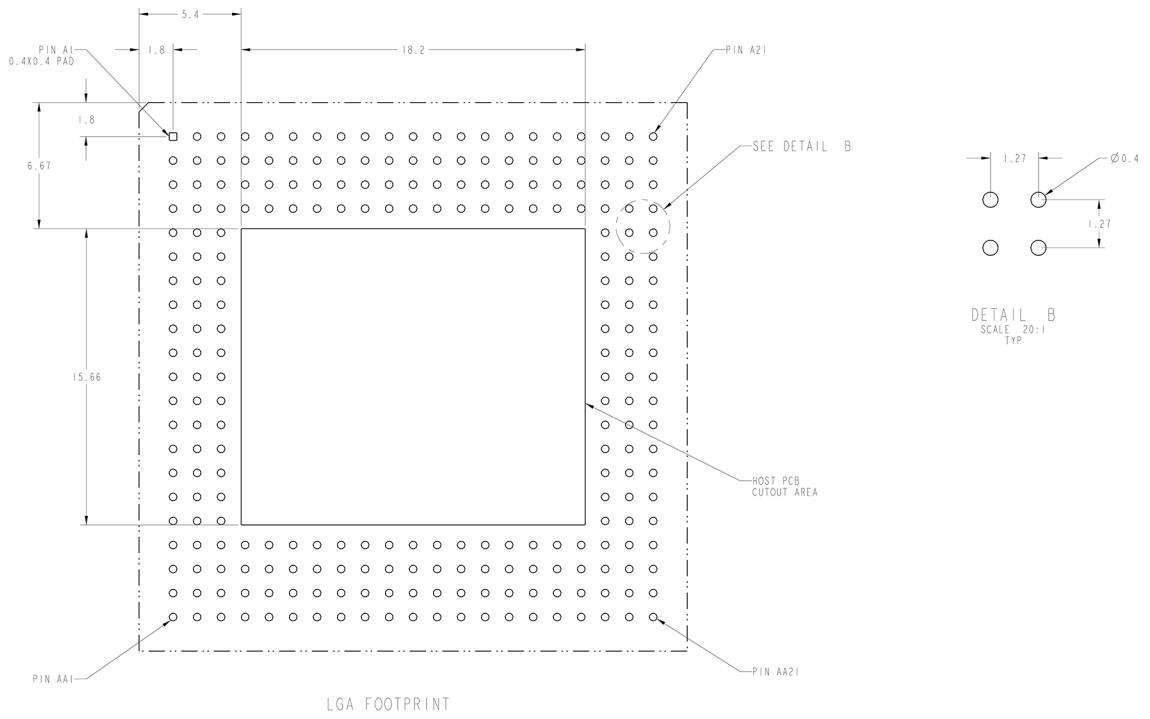

Digi SMTplus™ Castellated Edge Via mounting

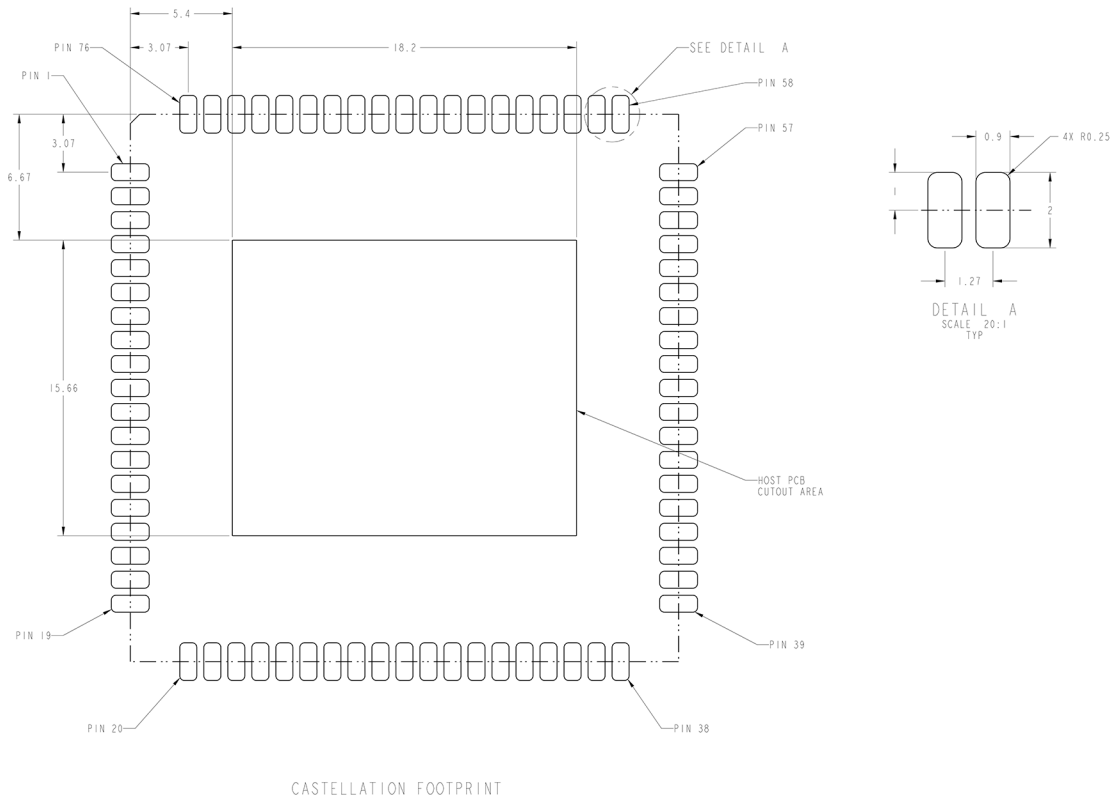

Weight

The weight of the ConnectCore 6UL module (with Wi-Fi/BT networking and shield) is 6.45g.

Environmental specifications

- Operating temperature: -40 to 85C.
- The ConnectCore 6UL module shall be built in an enclosure so that the shield is not accessible to the end-user.

Socket options

For testing, prototyping, and other primarily development-related purposes, Digi International and E-tec Interconnect AG have developed sockets allowing the easy insertion and removal of modules in a carrier board design. Socket models for both LGA and castellated via use cases are available.

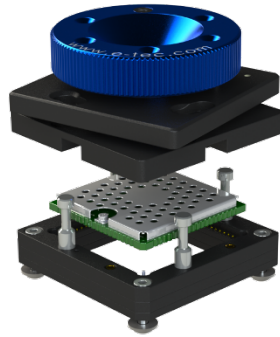

All drawings, user instructions, schematics, and PCB footprints are posted on the [ConnectCore 6UL technical support website](#).

Note The ConnectCore 6UL SBC Express (Digi P/N CC-WMX6UL-START) has been designed to support a LPF076-1290-19AB55L socket, and can be used as a reference design.

All sockets are sold and built by E-tec Interconnect AG (www.e-tec.com). The table below provides an overview of the available part numbers.

Socket model	E-tec part number
ConnectCore 6UL Castellated Vias	LPF076-1290-19AB55L
ConnectCore 6UL LGA	LPF245-1270-21AB55A + MGS245-SB01-21A9512

Note Please direct all socket-related purchase inquiries to E-tec Interconnect AG (info@e-tec.com).

Assembly instructions

Moisture sensitivity and shelf life	128
Mounting	128
Solder paste print	128
Stencil	128
Coplanarity	128
SMT pick and place	129
SMT process parameter reference - for both castellated and LGA applications	129
Reflow profiles using a ten-zone oven, SAC 305 lead-free solder paste (Alpha OM-340)	129
Vapor Phase Profile Recommendation Using IBL 309 Batch Soldering Machine, SAC 305 Lead-Free Solder Paste (Alpha OM-340)	130
Vapor Phase IBL 309 batch soldering machine settings	132
Conformal coating	132

Moisture sensitivity and shelf life

1. The ConnectCore 6UL module is classified as a Level 3 Moisture Sensitive Device in accordance with IPC/JEDEC J-STD-020.
2. Calculated shelf life in sealed packaging: 12 months at <40°C and <90% relative humidity (RH).
3. Environmental condition during production: 30°C /60% RH according to IPC/JEDEC J-STD -033C, paragraph 5.
4. Maximum time between opening of the sealed packaging and reflow process must not exceed 168 hours, based on condition b), IPC/JEDEC J-STD -033C, paragraph 5.2.
5. Baking is required, if conditions b) or c) do not apply. See above.
6. Baking is required, if the packaging humidity indicator indicates 10% RH or higher.
7. If baking is required, bake modules in trays 4-6 hours at 125°C; maximum stacking height is 10 trays.

Mounting

The ConnectCore 6UL module has been designed with easy integration into existing SMT processes in mind. This section contains guidance for mounting the module on your carrier board.

The module can be configured and mounted in a Castellated OR Land Grid Array (LGA) form.

Modules are also not sealed and therefore they should not be subjected to a wash cycle or similar treatment where condensation could occur. Contact Digi International for additional guidance to discuss conformal coating approaches and options, if needed. The module is built with a No-Clean flux solder paste. The module is provided to the user clean.

The following solder paste type has been approved for mounting the module on a carrier board:

- SAC305 (Lead-free: Alpha OM-340 Type 4 or equivalent). This is a No-Clean Flux solder paste.

Solder paste print

The following solder paste printing parameters are recommended:

- Stencil thickness: 0.100 mm / 4 mil
- Stencil diameter: One to one of pad diameter (to +20% of pad)
- Paste alignment: 20% off the pad max (offset <20% pad diameter)

Stencil

For both castellated AND LGA applications, Digi recommends you use a laser cut and/or electro-formed stencil for placing the ConnectCore 6UL module. Based on the actual coplanarity characteristics of your carrier board, adjustments may be required to determine the optimal solder paste volume. It is also recommended to perform an X-ray analysis of the initial production run of your assembly with the ConnectCore 6UL module. Please contact Digi for additional support.

Coplanarity

The coplanarity measured on the ConnectCore 6UL module is <0.003" bow and twist (98% confidence interval). It is important that the carrier board is also coplanar. If the carrier board is thinner than the

ConnectCore 6UL module it is recommended that the assembly be supported during the reflow process, i.e. reflow fixture should be used to minimize the potential bow of the carrier card.

SMT pick and place

- Placement nozzle: Largest available on the machine.
- Nozzle Pick Surface: Center of shield on i.MX6UL SoM.
- Placement Speed: Slowest speed for the machine.
- Placement alignment: 10% of pad diameter (compensating for module weight and supporting alignment). The module should be placed last as part of the assembly/mounting process to eliminate unexpected shifting.

SMT process parameter reference - for both castellation and LGA applications

Process	SMT process	Specification recommendations
Screen Print	Solder paste	SAC 305 No-Clean (Alpha OM-340 or equivalent)
	Stencil thickness	0.100mm / 4mil
	Recommended aperture size	0.55mm / 22mil rounded square (LGA) 1:1 with pad (castellation)
	Paste alignment	20% maximum off center of the pad
PnP	Placement nozzle	Largest available on machine
	Nozzle pick surface	Shield center
	Speed	Slowest possible with PnP machine
	Placement sequence	Last, if possible
	Placement alignment	10% maximum off center of pad
Reflow	See Reflow profiles using a ten-zone oven, SAC 305 lead-free solder paste (Alpha OM-340) .	

Reflow profiles using a ten-zone oven, SAC 305 lead-free solder paste (Alpha OM-340)

- Recommend to keep SOM below 238°C during the reflow cycle for castellation AND LGA applications
- Time Above Liquidous (TAL) is recommended to be between 56 to 63 seconds.
- Use of 40AWG K-type thermocouple and M.O.L.E or equivalent thermal profiler is recommended.

- For castellation applications, only one thermal couple is required. Digi recommends it is located on a ground pad castellation.
- For LGA applications, two thermocouples should be used: one located on the outer-most row and a second located near the underside center of the SOM to ensure SOM is not exposed to excessive temperatures.

The following image shows the reflow profile based on a ten-zone convection oven.

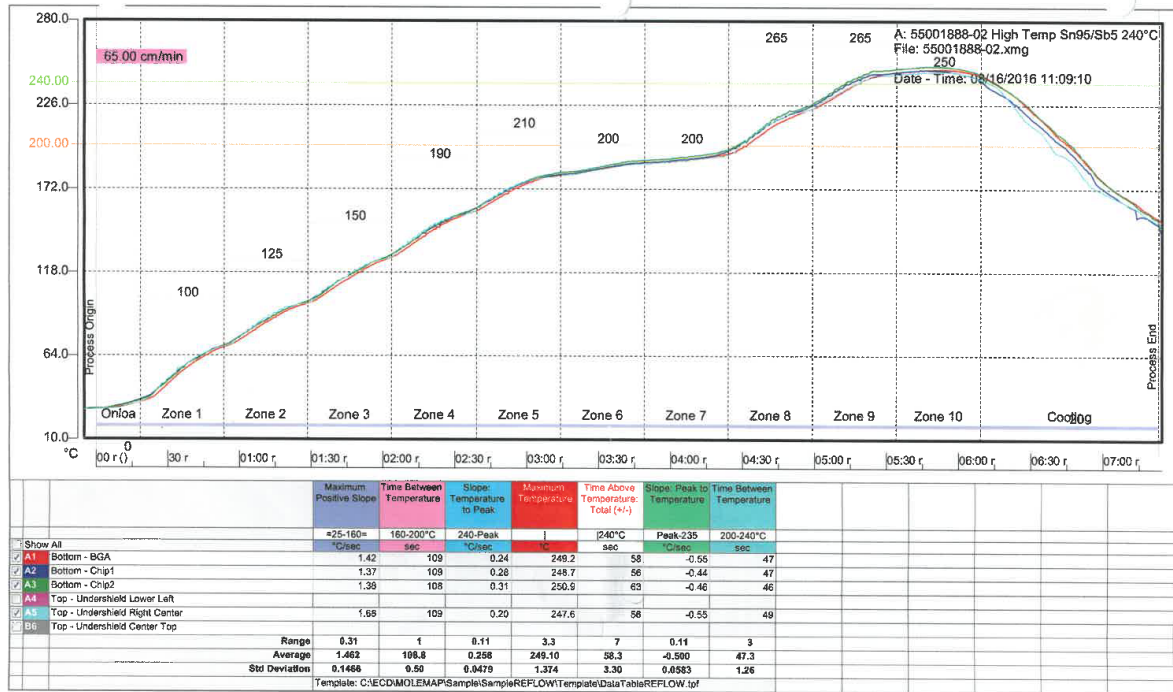

The reflow profile shown above is valid for the combination solder paste/reflow machine and Digi reference carrier board. Optimization of a reflow profile will depend on the selected solder paste/reflow machine (reflow or vapor phase) and carrier board design.

The ConnectCore 6UL module is approved to withstand a total of four (4) reflow cycles. Two (2) reflow cycles are required for manufacturing the ConnectCore 6UL module. Two (2) reflow cycles are remaining for mounting the module on the carrier board. Digi strongly recommends soldering the ConnectCore 6UL module during the last reflow cycles of the carrier board manufacturing process.

Vapor Phase Profile Recommendation Using IBL 309 Batch Soldering Machine, SAC 305 Lead-Free Solder Paste (Alpha OM-340)

- Recommend to keep SOM below 235°C during the reflow cycle for castellation AND LGA applications:
 - This is controlled by the Solvay Plastics, Galden XS230 vapor fluid; maximum soldering temperature 230C for unleaded solder.

- Vapor Phase heat transfers faster than reflow meaning Time Above Liquidous (TAL) is shorter. Digi recommends TAL to be between 40 and 45 seconds.
- Use of 40AWG K-type thermocouple and M.O.L.E or equivalent thermal profiler is recommended.
- For castellation applications, only one thermal couple is required recommended to be location on a ground pad castellation.
- For LGA applications, two thermocouples should be used. One located on the outer most row and a second location should be near the underside center of the SoM to ensure SoM is not exposed to excessive temperatures
- Solder Pallet shall be used that can be processed through screen print, Pick & Place and vapor phase.

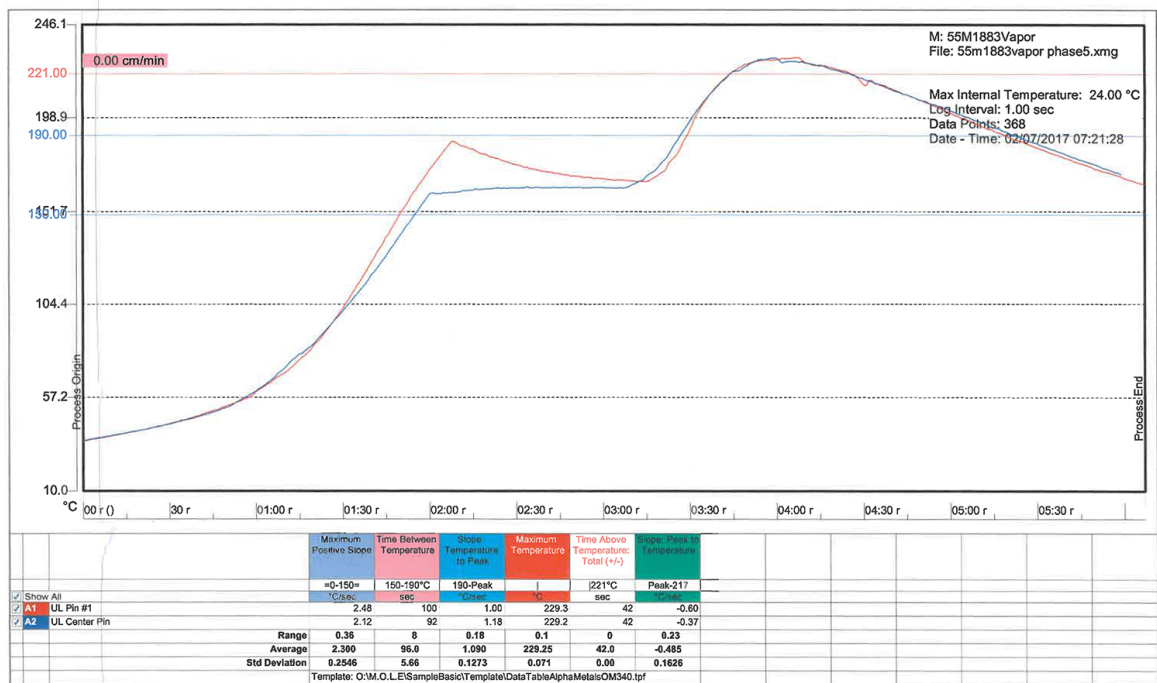

Vapor Phase IBL 309 batch soldering machine settings

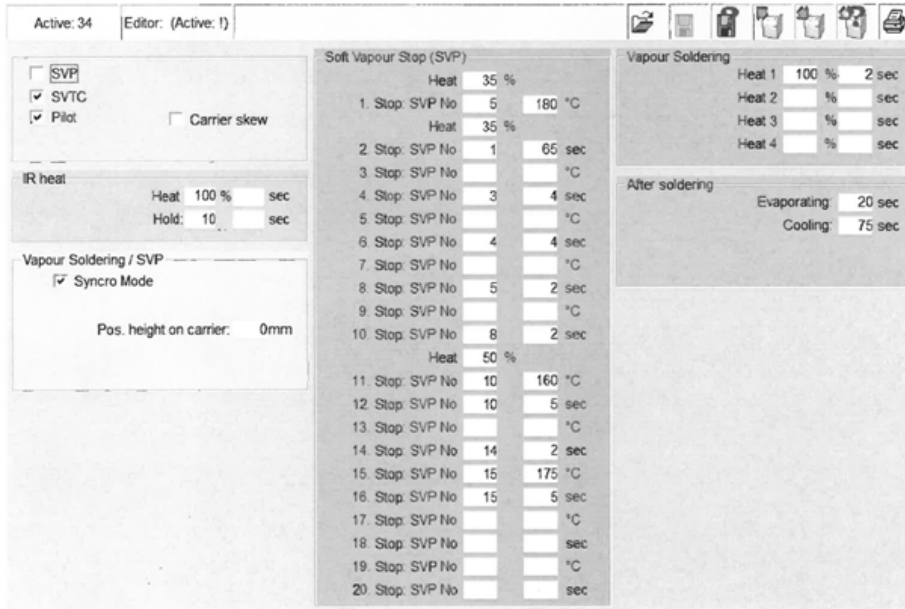

Conformal coating

The ConnectCore 6UL module may be conformally coated using an IPC-CC-830 compliant Acrylic (Type AR) coating material. The material shall be applied by spray application IPC-A-610. DIP coating is method shall not be used. If other coating material is required Urethane (Type UR), Silicone (Type SR) or Epoxy (Type ER) please contact Digi.

Certifications

External antenna	134
United States FCC	134
Europe	136
Canada (IC)	136
Japan	138

External antenna

In order to reuse the FCC and IC modular approval of the ConnectCore 6UL module when using the external antenna connected to pad B13 (RF_ANT_EXT), the exact same circuitry as in the schematics and PCB routing of the ConnectCore 6UL SBC PRO must be used. Exact routing information can be found on the product support page in the section Design Documents / ConnectCore 6UL SBC Project (ALTIUM). In this document, you can find the corresponding PCB material used, trace width and length.

United States FCC

The ConnectCore 6UL module complies with Part 15 of the FCC rules and regulations. Compliance with the labeling requirements, FCC notices and antenna usage guidelines is required. To fulfill FCC Certification, the OEM must comply with the following regulations:

The system integrator must ensure that the text on top side of the module is placed on the outside of the final product.

ConnectCore 6UL module may only be used with antennas approved. See [FCC-approved antennas](#).



WARNING! The Original Equipment Manufacturer (OEM) must ensure that FCC labeling requirements are met. This includes a clearly visible label on the outside of the final product enclosure that displays the contents shown below. Required FCC Label for OEM products containing the ConnectCore 6UL module.

Contains FCC ID: MCQ-CCIMX6UL

This device complies with part 15 of the FCC Rules. Operation is subject to the following two conditions: (1) This device may not cause harmful interference, and (2) this device must accept any interference received, including interference that may cause undesired operation.

FCC notices

IMPORTANT: The ConnectCore 6UL module has been certified by the FCC for use with other products without any further certification (as per FCC section 2.1091). Modifications not expressly approved by Digi could void the user's authority to operate the equipment.

IMPORTANT: OEMs must test final product to comply with unintentional radiators (FCC section 15.107 & 15.109) before declaring compliance of their final product to Part 15 of the FCC Rules.

IMPORTANT: The ConnectCore 6UL module has been certified for remote and base radio applications. If the module will be used for portable applications, the device must undergo SAR testing. This equipment has been tested and found to comply with the limits for a Class B digital device, pursuant to Part 15 of the FCC Rules. These limits are designed to provide reasonable protection against harmful interference in a residential installation. This equipment generates uses and can radiate radio frequency energy, and if not installed and used in accordance with the instructions, may cause harmful interference to radio communications. However, there is no guarantee that interference will not occur in a particular installation. If this equipment does cause harmful interference to radio or television reception, which can be determined by turning the equipment off and on, the user is encouraged to try to correct the interference by one or more of the following measures: Re-orient or relocate the receiving antenna, Increase the separation between the equipment and receiver, Connect equipment and receiver to outlets on different circuits, or Consult the dealer or an experienced radio/TV technician for help.

IMPORTANT: ConnectCore 6UL module is for professional (OEM) installation only.

FCC-approved antennas

The ConnectCore 6UL module can be installed utilizing antennas and cables constructed with non-standard connectors (RPSMA, RPTNC, and so on).

The modules are FCC approved for fixed base station and mobile applications for the channels indicated in the tables below. If the antenna is mounted at least 20cm (8 in.) from nearby persons, the application is considered a mobile application. Antennas not listed in the table must be tested to comply with FCC Section 15.203 (Unique Antenna Connectors) and Section 15.247 (Emissions).

The antennas in the tables below have been approved for use with this module. Digi does not carry all of these antenna variants. Contact Digi Sales for available antennas.

Antennas approved for use with the ConnectCore 6UL Wi-Fi modules

Part number	Type (description)	Peak gain 2.4 GHz	Peak gain 5 GHz
Linx Technologies Inc. ANT-DB1-RAF-RPS	Dipole, articulated RPSMA, dual band 2.4 GHz & 5 GHz	2.5	4.6
Ethertronics 1001932	PCB antenna, dual band 2.4 GHz & 5 GHz	2.5	4.4
Yageo ANTX100P001B24553	PCB antenna, dual band 2.4 GHz & 5 GHz	4.6	5.1

Note If using the RF module in a portable application (for example - if the module is used in a hand-held device and the antenna is less than 20cm from the human body when the device is in operation): The integrator is responsible for passing additional SAR (Specific Absorption Rate) testing based on FCC rules 2.1091 and FCC Guidelines for Human Exposure to Radio Frequency Electromagnetic Fields, OET Bulletin and Supplement C. The testing results will be submitted to the FCC for approval prior to selling the integrated unit. The required SAR testing measures emissions from the module and how they affect the person.

Note When using Linx Technologies Inc. ANTDB1-RAF-RPS antenna, make sure to use a cable of minimum 10cm long and of type RG-178.

RF exposure



CAUTION! To satisfy FCC RF exposure requirements for mobile transmitting devices, a separation distance of 20 cm or more should be maintained between the antenna of this device and persons during device operation. To ensure compliance, operations at closer than this distance are not recommended. The antenna used for this transmitter must not be co-located in conjunction with any other antenna or transmitter. The preceding statement must be included as a CAUTION statement in OEM product manuals in order to alert users of FCC RF Exposure compliance.

Europe

- 2.412 to 2.472 GHz; 13 channels
- 5.180 to 5.320 GHz; 8 channels
- 5.500 to 5.700 GHz, 8 channels (excludes 5.600 to 5.640 GHz)

OEM labeling requirements

The **CE** marking must be affixed to a visible location on the OEM product.

CE labeling requirements

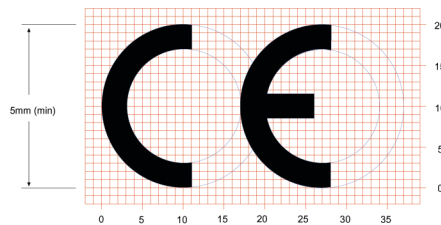

The CE mark shall consist of the initials **CE** taking the following form:

- If the CE marking is reduced or enlarged, the proportions given in the above graduated drawing must be respected.
- The CE marking must have a height of at least 5mm except where this is not possible on account of the nature of the apparatus.
- The CE marking must be affixed visibly, legibly, and indelibly.

Declarations of Conformity

Digi has issued Declarations of Conformity for the ConnectCore 6UL system-on-module concerning emissions, EMC, and safety. For more information, see <http://www.digi.com/resources/certifications>.

Important note

Digi customers assume full responsibility for learning and meeting the required guidelines for each country in their distribution market. Refer to the radio regulatory agency in the desired countries of operation for more information.

Approved antennas

The same antennas have been approved for Europe as stated in the FCC table for use with the ConnectCore 6UL module.

Canada (IC)

IC: 1846A-CCIMX6UL

PMN: CC IMX6UL

HVIN: ConnectCore 6UL

This device complies with Industry Canada license-exempt RSS standard(s). Operation is subject to the following two conditions: (1) this device may not cause interference, and (2) this device must accept any interference, including interference that may cause undesired operation of the device.

Le présent appareil est conforme aux CNR d'Industrie Canada applicables aux appareils radio exempts de licence. L'exploitation est autorisée aux deux conditions suivantes : (1) l'appareil ne doit pas produire de brouillage, et (2) l'utilisateur de l'appareil doit accepter tout brouillage radioélectrique subi, même si le brouillage est susceptible d'en compromettre le fonctionnement.

Labeling requirements

Labeling requirements for Industry Canada are similar to those of the FCC. A clearly visible label on the outside of the final product enclosure must display the following text:

Contains Model ConnectCore™ for i.MX6UL Radio, IC: 1846A-CCIMX6UL

The Product Marketing Name (PMN) of the product is: CC IMX6UL.

Transmitters with detachable antennas

This radio transmitter (IC: 1846A-CCIMX6UL) has been approved by Industry Canada to operate with the antenna types listed in the table above with the maximum permissible gain and required antenna impedance for each antenna type indicated. Antenna types not included in this list, having a gain greater than the maximum gain indicated for that type, are strictly prohibited for use with this device.

Le présent émetteur radio (IC: 1846A-CCIMX6UL) a été approuvé par Industrie Canada pour fonctionner avec les types d'antenne énumérés ci-dessous et ayant un gain admissible maximal et l'impédance requise pour chaque type d'antenne. Les types

d'antenne non inclus dans cette liste, ou dont le gain est supérieur au gain maximal indiqué, sont strictement interdits pour l'exploitation de l'émetteur.

Under Industry Canada regulations, this radio transmitter may only operate using an antenna of a type and maximum (or lesser) gain approved for the transmitter by Industry Canada. To reduce potential radio interference to other users, the antenna type and its gain should be so chosen that the equivalent isotropically radiated power (e.i.r.p.) is not more than that necessary for successful communication.

Conformément à la réglementation d'Industrie Canada, le présent émetteur radio peut fonctionner avec une antenne d'un type et d'un gain maximal (ou inférieur) approuvé pour l'émetteur par Industrie Canada. Dans le but de réduire les risques de brouillage radioélectrique à l'intention des autres utilisateurs, il faut choisir le type d'antenne et son gain de sorte que la puissance isotrope rayonnée équivalente (p.i.r.e.) ne dépasse pas l'intensité nécessaire à l'établissement d'une communication satisfaisante.

ConnectCore 6UL module is for professional (OEM) installation only.

Le module ConnectCore 6UL doit impérativement être installé par un professionnel (OEM).

RF exposure



To satisfy Industry Canada RF exposure requirements, a separation distance of 20 cm or more should be maintained between the antenna of this device and persons during device operation.

Pour satisfaire aux exigences d'Industrie Canada concernant l'exposition RF, une distance égale ou supérieure à 20cm doit être respectée entre les antennes de ce produit et les personnes se trouvant à proximité.

The preceding statement must be included as a CAUTION statement in OEM product manuals in order to alert users of Industry Canada RF Exposure compliance.

Cette information doit être incluse dans le manuel du produit OEM afin d'alerter les utilisateurs sur la nécessité de respecter l'exposition RF d'Industrie Canada.

Approved antennas

The same antennas have been approved for Canada as stated in the FCC table for use with the ConnectCore 6UL module.

Japan

電波法により5GHz帯は屋内使用に限ります。

This device has been granted a designation number by Ministry of Internal Affairs and Communications according to:

Ordinance concerning Technical Regulations Conformity Certification etc. of Specified Radio Equipment (特定無線設備の技術基準適合証明等に関する規則).

- Article 2, Paragraph 1, Item 19, 19-3, 19-3-2 Category: WW, XW, YW
- Model/Name of equipment: ConnectCore 6UL
- Radio label marking:
 - R: 202-LSF056
 - T: D 17-0014 202

This device should not be modified (otherwise the granted designation number will be invalid).

- 2.412 to 2.472 GHz; 13 channels
- 5.180 to 5.320 GHz; 8 channels
- 5.500 to 5.700 GHz; 11 channels

Approval Label (MIC Marking)

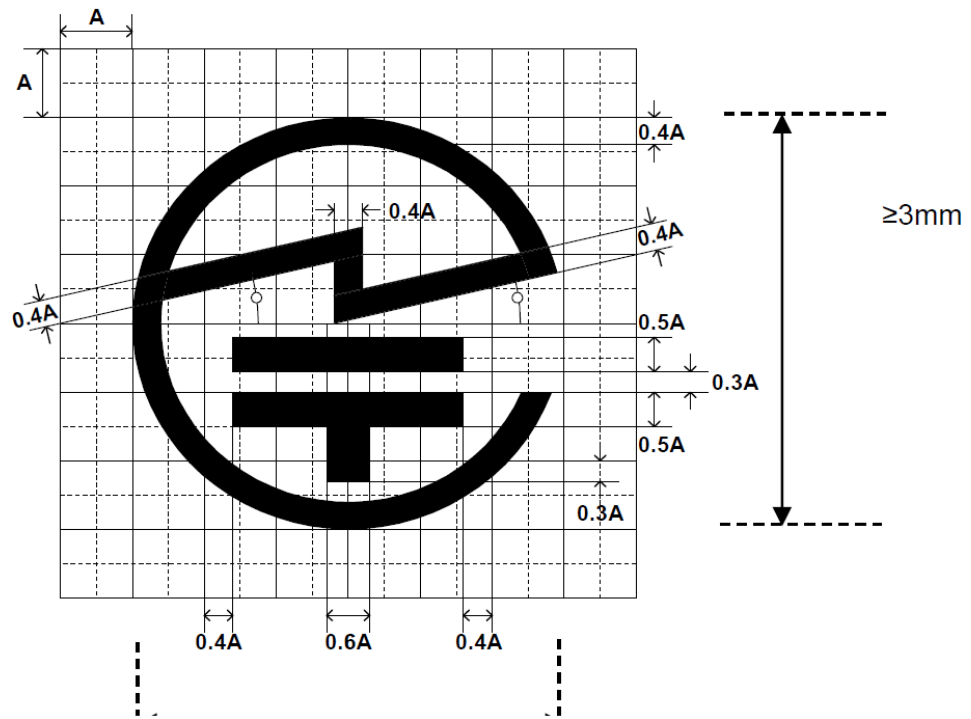

Label text

