



Accredited testing-laboratory

DAR registration number: DGA-PL-176/94-D1

**Federal Motor Transport Authority (KBA)
DAR registration number: KBA-P 00070-97**

Recognized by the Federal Communications Commission

Anechoic chamber registration no.: 90462 (FCC)

Anechoic chamber registration no.: 3462C-1 (IC)

Certification ID: DE 0001

Accreditation ID: DE 0002

Accredited Bluetooth® Test Facility (BQTF)

*The Bluetooth word mark and logos are owned by the Bluetooth SIG,
Inc. and any use of such marks by Cetecom ICT is under license*

Test report no. : 1-1796-01-03/09-A
Type identification : 50001589-XX
Applicant : Digi International GmbH
FCC ID : MCQ-50M1589
IC Certification No : 1846A-50M1589
Test standards : 47 CFR Part 15
RSS - 210 Issue 7

Table of contents

1	General information	3
1.1	Notes	3
1.2	Testing laboratory	4
1.3	Details of applicant	4
1.4	Application details	4
2	Test standard/s	5
3	Technical tests	6
3.1	Details of manufacturer.....	6
3.1.1	Test item.....	6
3.1.2	Additional EUT information For IC Canada (appendix 2).....	7
3.1.3	EUT operating modes.....	8
3.1.4	Extreme conditions testing values	8
4	Summary of Measurement Results and list of all performed test cases	9
5	RF measurement testing	10
5.1	Description of test set-up.....	10
5.1.1	Radiated measurements.....	10
5.1.2	Conducted measurements.....	10
5.2	Referenced Documents	11
5.3	Additional comments	12
5.4	Manufacturer´s Declaration.....	12
5.5	Antenna gain	12
5.6	Band-edge compliance of radiated emissions §15.205	13
5.7	Spurious Emissions - radiated (Transmitter) §15.209.....	15
5.8	Spurious Emissions - radiated (Receiver) §15.109 / 209	30
5.9	Spurious Emissions - radiated <30 MHz §15.209.....	33
5.10	Conducted Emissions <30 MHz §15.107/207.....	35
6	Test equipment and ancillaries used for tests	38
7	Photographs of the Test Set-up	40
8	Photographs of the EUT	41

1 General information

1.1 Notes

The test results of this test report relate exclusively to the test item specified in 3.1.1. The CETECOM ICT Services GmbH does not assume responsibility for any conclusions and generalisations drawn from the test results with regard to other specimens or samples of the type of the equipment represented by the test item. The test report may only be reproduced or published in full. Reproduction or publication of extracts from the report requires the prior written approval of the CETECOM ICT Services GmbH.

Test laboratory manager:

2010-06-08	Meheza Kpelou Walla	
Date	Name	Signature

Technical responsibility for area of testing:

2010-06-08	Jakob Reschke	
Date	Name	Signature

1.2 Testing laboratory

CETECOM ICT Services GmbH

Untertürkheimer Straße 6 - 10
66117 Saarbrücken
Germany
Phone: + 49 681 5 98 - 0
Fax: + 49 681 5 98 - 9075
E-mail: info@ICT.cetecom.de
Internet: http://www.cetecom-ict.de

State of accreditation: The test laboratory (area of testing) is accredited according to
DIN EN ISO/IEC 17025
DAR registration number: DGA-PL-176/94-D1

Accredited by: Federal Motor Transport Authority (KBA)
DAR registration number: KBA-P 00070-97

Testing location, if different from CETECOM ICT Services GmbH:

Name :
Street :
Town :
Country :
Phone :
Fax :

1.3 Details of applicant

Name:	Digi International GmbH Branch Breisach
Street:	Kueferstr.8
Town:	79206 Breisach
Country:	Germany
Telephone:	
Fax:	+49 7667 908 200
Contact:	Andreas Ortlieb
E-mail:	andreas.ortlieb@digi.com
Telephone:	+49 7667 908 136

1.4 Application details

Date of receipt of order:	2009-11-16
Date of receipt of test item:	2010-05-06
Date of start test:	2010-05-06
Date of end test	2010-06-08
Persons(s) who have been present during the test:	-/-

2 Test standard/s

47 CFR Part 15	2008-07	Title 47 of the Code of Federal Regulations; Chapter I- Federal Communications Commission subchapter A - general, Part 15-Radio frequency devices
RSS - 210 Issue 7	2007-06	Spectrum Management and Telecommunications - Radio Standards Specification Low-power Licence-exempt Radiocommunication Devices (All Frequency Bands): Category I Equipment

3 Technical tests

3.1 Details of manufacturer

Name:	Digi International GmbH Branch Breisach
Street:	Kueferstr.8
Town:	79206 Breisach
Country:	Germany

3.1.1 Test item

Kind of test item	:	2,4 GHz WLAN Modul b,g
Type identification	:	50001589-XX
S/N serial number	:	-/-
HW hardware status	:	-/-
SW software status	:	-/-
Frequency Band [MHz]	:	ISM Band 2.400 - 2.483,5 MHz (Channel 1 – 2412 MHz; Channel 11 – 2462 MHz)
Type of Modulation	:	DSSS & OFDM – QPSK, 16/64 QAM
Number of channels	:	11
Antenna	:	External rod. antenna
Power Supply	:	115 V AC / 60 Hz to 12 V DC from Power Adaptor TR10R0120
Temperature Range	:	-20 °C to +55 °C

Max. power radiated: 26.60 dBm (calculated)
 Max. power conducted: 24.30 dBm (Refer to test report number: 08KFE010163-C-02)

FCC ID: MCQ-50M1589
 IC: 1846A-50M1589

3.1.2 Additional EUT information For IC Canada (appendix 2)

IC Registration Number:	1846A-50M1589
Model Name:	50001589-XX
Manufacturer (complete Address):	Digi International GmbH Kueferstr.8 79206 Breisach Germany
Tested to Radio Standards Specification (RSS) No.:	RSS-210 Issue 7
Open Area Test Site Industry Canada Number:	IC 3462C-1
Frequency Range (or fixed frequency) [MHz]:	ISM Band 2400 – 2483.5 MHz (Channel 1 – 2412 MHz; Channel 11 – 2462 MHz)
RF: Power [W] (max):	<u>DSSS:</u> Rad. EIRP (calculated): 457.09 mW Conducted: 269.15 mW Refer to test report number: 08KFE010163-C-02 <u>OFDM:</u> Rad. EIRP (calculated): 128.82 mW Conducted: 75.86 mW Refer to test report number: 08KFE010163-C-02
Antenna Type:	External rod. antenna
Occupied Bandwidth (99% BW) [kHz]:	Not performed! Only delta measurement radiated
Type of Modulation:	DSSS & OFDM – QPSK, 16/64 QAM
Emission Designator (TRC-43):	Not performed! Only delta measurement radiated
Transmitter Spurious (worst case) [dBµV/m in 10m]:	32.60
Receiver Spurious (worst case) [dBµV/m in 10m]:	32.60

ATTESTATION:

I attest that the testing was performed or supervised by me; that the test measurements were made in accordance with the above-mentioned departmental standard(s), and that the radio equipment identified in this application has been subject to all applicable test conditions specified in the departmental standards and all of the requirements of the standards have been met.

Signature:

Test engineer: Meheza K. Walla
Date: 2010-06-08

3.1.3 EUT operating modes

EUT operating mode no. *)	Description of operating modes	Additional information
Op. 0	Normal mode	Normal temperature and power source conditions
Op. 1		low temperature, low power source conditions
Op. 2		low temperature, high power source conditions
Op. 3		high temperature, low power source conditions
Op. 4		high temperature, high power source conditions

*) EUT operating mode no. is used to simplify the test plan

3.1.4 Extreme conditions testing values

Description	Shortcut	Unit	Value
Nominal Temperature	T _{nom}	°C	23
Nominal Humidity	H _{nom}	%	42
Nominal Power Source	V _{nom}	V	115 V AC / 60 Hz To 12 V DC

Type of power source: **from Power Adapter TR10R0120**

4 Summary of Measurement Results and list of all performed test cases

- No deviations from the technical specifications were ascertained
- There were deviations from the technical specifications ascertained

TC identifier	Description	verdict	date	Remark
RF-Testing	FCC Part 15 §15.247 - CANADA RSS-210	PASS	2010-06-08	-/-

Test Specification Clause	Test Case	Pass	Fail	Not applicable	Not performed
§15.205	Band-edge compliance of radiated emissions	Yes			
§ 15.209	Spurious Emission -radiated (Transmitter)	Yes			
§ 15.109	Spurious Emissions-radiated (Receiver)	Yes			
§ 15.209	Spurious Emissions-radiated <30 MHz	Yes			
§ 15.107/207	Conducted Emissions <30 MHz	Yes			

5 RF measurement testing

5.1 Description of test set-up

5.1.1 Radiated measurements

The radiated measurements are performed in vertical and horizontal plane in the frequency range from 9 kHz to 20 GHz in semi-anechoic chambers. The EUT is positioned on a non-conductive support with a height of 0.80 m above a conductive ground plane that covers the whole chamber.

The receiving antennas are confirmed with specifications ANSI C63.2-1996 clause 15 and ANSI C63.4-2003 clause 4.1.5. These antennas can be moved over the height range between 1.0 m and 4.0 m in order to search for maximum field strength emitted from EUT. The measurement distances between EUT and receiving antennas are indicated in the test set-ups for the various frequency ranges. For each measurement, the EUT is rotated in all three axes until the maximum field strength is received.

The wanted and unwanted emissions are received by spectrum analysers where the detector modes and resolution bandwidths over various frequency ranges are set according to requirement ANSI C63.4-2003 clause 4.2.

Antennas are confirmed with ANSI C63.2-1996 item 15.

9 kHz - 150 MHz: Quasi Peak measurement, 200 Hz Bandwidth, passive loop antenna.

150 kHz - 30 MHz: Quasi Peak measurement, 9 kHz Bandwidth, passive loop antenna.

30 MHz - 200 MHz: Quasi Peak measurement, 120 kHz Bandwidth, biconical antenna

200MHz - 1GHz: Quasi Peak measurement, 120 kHz Bandwidth, log periodic antenna

>1GHz: Average, RBW 1MHz, VBW 10 Hz, wave guide horn

All measurement settings are according to FCC 15.209 and 15.207

5.1.2 Conducted measurements

Not performed! Only delta measurements radiated

The EUT's RF signal is coupled out by the antenna connector which is supplied by the manufacturer. The signal is connected to the spectrum analyzer. The specific losses for signal path are first checked within a calibration. The measurement readings on the spectrum analyzer are corrected by the specific test set-up loss. The attenuator, power divider, signalling unit and the spectrum analyzer are impedance matched on 50 Ohm.

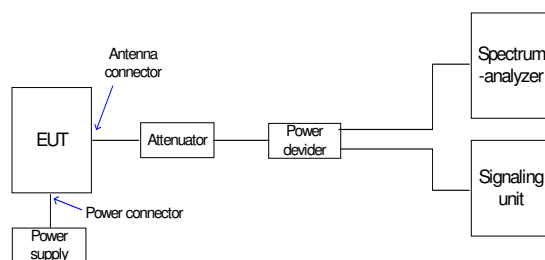

5.2 Referenced Documents

Pre-certified WLAN-module used. Only delta-measurements performed.

Refer to test report number: 08KFE010163-C-02 for the full tests.

Antenna specification: 802.11a/b/g antenna

Attributes

Attribute	Band 1	Band 2
Frequency	2.4-2.483.5GHz	5.15GHz-6GHz
Bandwidth	120MHz	875MHz
Wavelength	¼ Wave	¼ Wave
Impedance	50 Ohm	50 Ohm
VSWR	< 1.9 typ. Center	< 1.9 typ. Center
Connector	RP-SMA	RP-SMA
Gain	2.3dBi	3.6dBi
Dimension	See measurements in the drawing after the table.	
Maximum Power level	TBD	TBD
Operating temperature	TBD	TBD
Storage temperature	TBD	TBD
Part number	ANT-DB1-RAF-RPS	

Dimensions

Note: Dimensions are provided for reference purposes only. The actual antenna might vary.

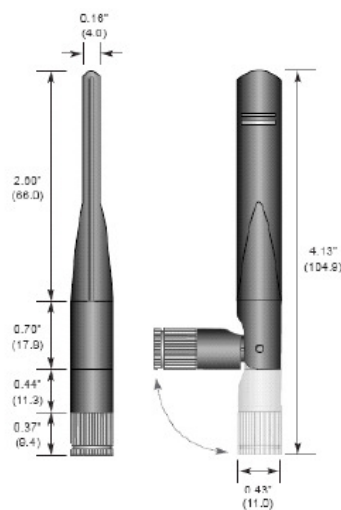

Cable specification : U.FL/W.FL to RP-SMA FEMALE

Attributes

Attribute	Property
Impedance	50 Ohm
Frequency Range	0 to 6 GHz
Length	150 mm /
Temperature Range	-40 to +90°C
Loss	3.8dB/m (3 GHz) 5.6dB/m (6 GHz)

Dimensions

Note: Dimensions are provided for reference purposes only. The actual cable might vary.

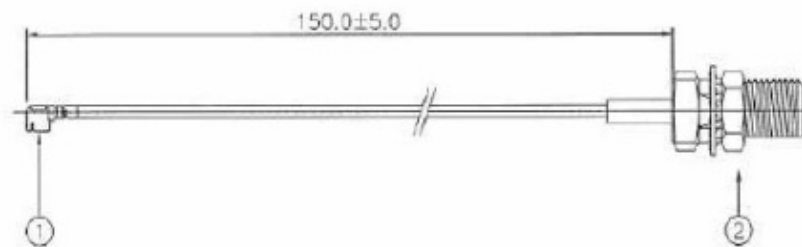

- 1 = U.FL
- 2 = RP-SMA

Note: This module obtained its complete certification by using the cable described here. End users in North America should use a cable that matches these specs to maintain the module's certification.

5.3 Additional comments

The manufacturer had a special software to set the EUT in continuous transmission with a duty cycle of 99%. The EUT was configured (configuration via HyperTerminal) to operate with power index 50 by B – Mode using 11 Mbit/s and with a power index 50 by G – Mode using 54 Mbit/s. The conducted output power was measured and it was the same as in the referenced test report.

5.4 Manufacturer's Declaration

The manufacturer attests that the power settings used for testing are part of the firmware and cannot be changed by the user or host. The following measurements were performed with the specific power settings fulfilling the requirements of the FCC- and IC- rules.

5.5 Antenna gain

Refer to "5.2 Referenced document" the antenna gain is 2.3 dBi.

5.6 Band-edge compliance of radiated emissions §15.205

DSSS:

Plot 1: lowest channel

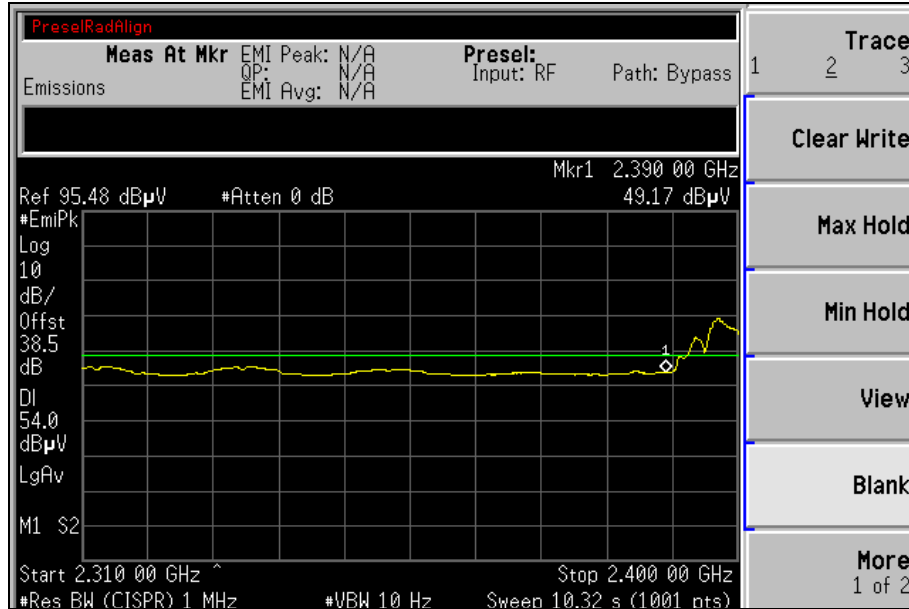

Plot 2: highest channel

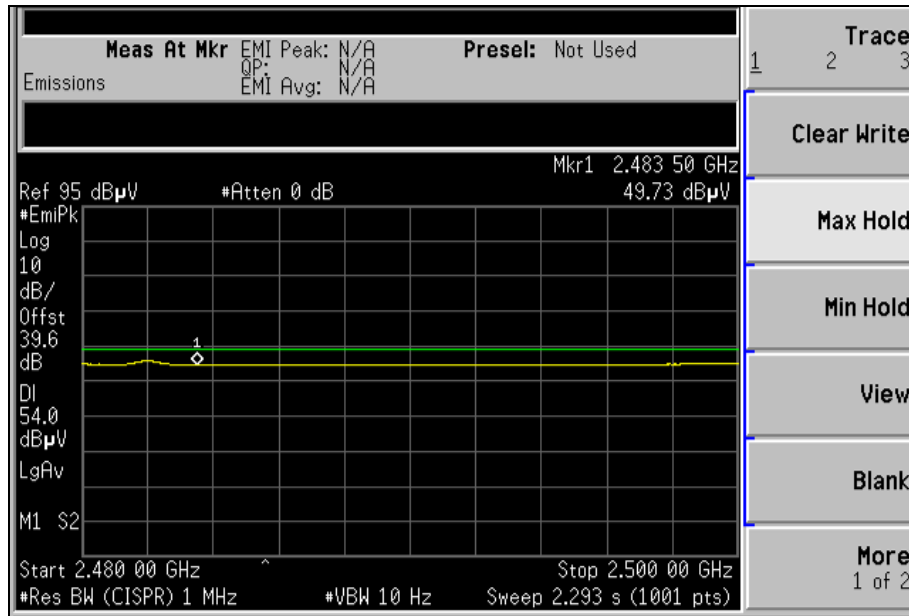

Limit: 54 dBµV/m	Complies
-------------------------	-----------------

OFDM:

Plot 3: lowest channel

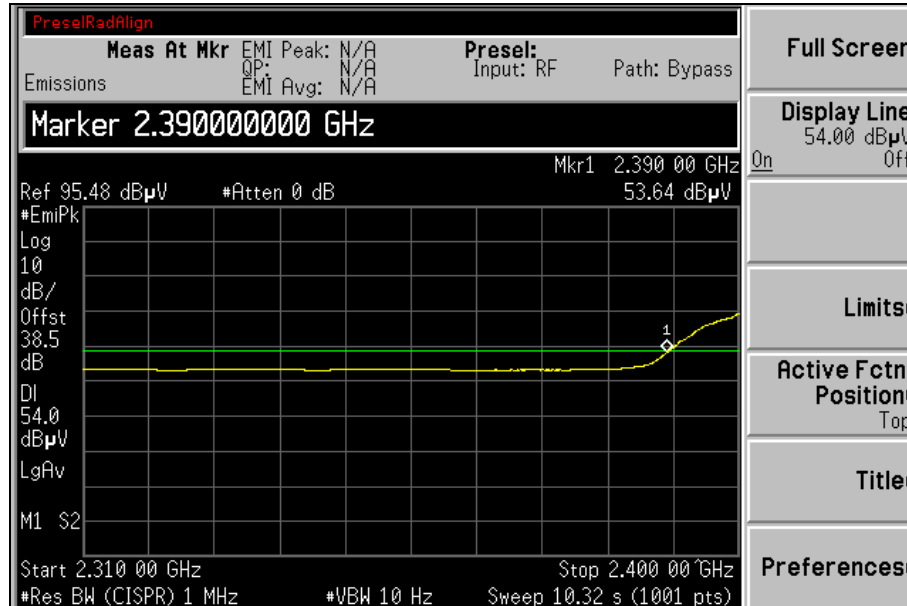

Plot 4: highest channel

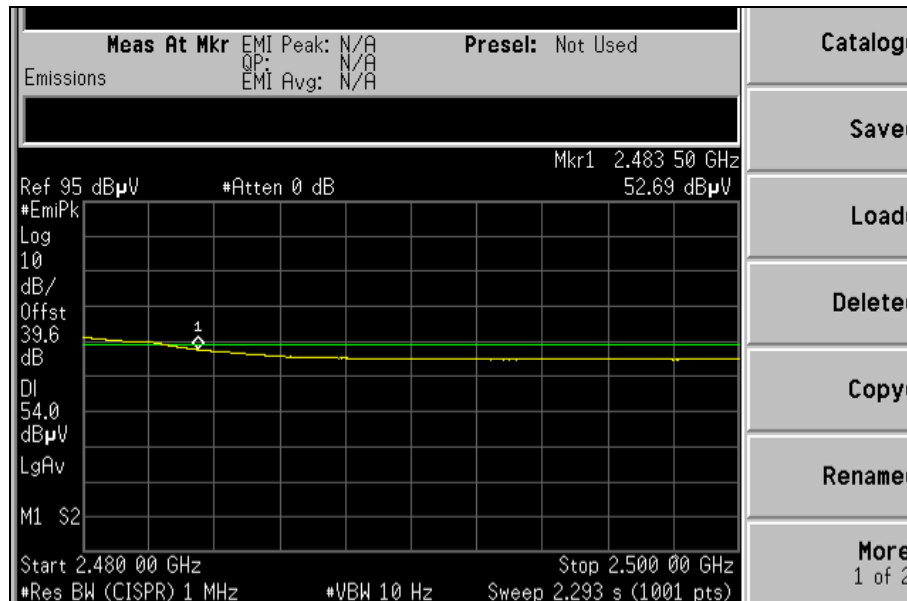

Limit: 54 dBµV/m		Complies
------------------	--	----------

5.7 Spurious Emissions - radiated (Transmitter) §15.209

DSSS:

Plot 1: 0.03 - 1 GHz, antenna vertical/horizontal (lowest channel) @ 10 m

Information

EUT:	50001589-XX + AC/DC Adaptor
Serial Number:	Prototype + 24000093
Test Description:	FCC Part 15
Operating Conditions:	WLAN test mode B, channel 1
Operator Name:	Kraus
Comment:	Powered with 115V / 60Hz

Scan Setup: STAN_Fin [EMI radiated]

Hardware Setup:	Electric Field (NOS)
Level Unit:	dBµV/m

Subrange	Detectors	IF Bandwidth	Meas. Time	Receiver
30 MHz - 1,05 GHz	QuasiPeak	120 kHz	15 s	Receiver

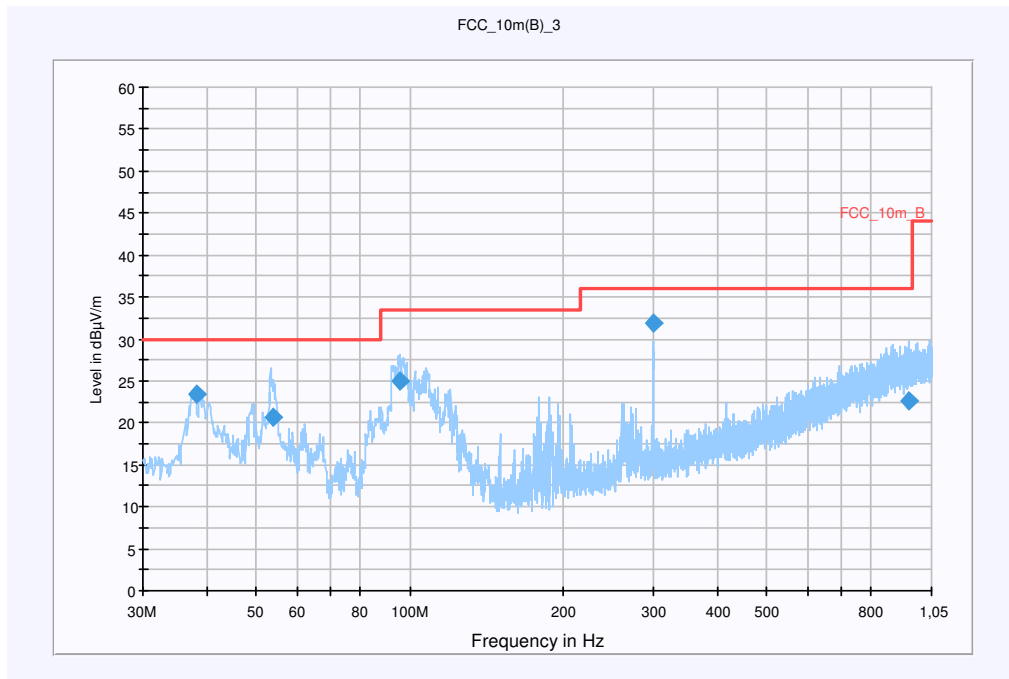

Frequency (MHz)	QuasiPeak (dBµV/m)	Meas. Time (ms)	Bandwidth (kHz)	Antenna height (cm)	Polarity	Turntable position (deg)	Corr. (dB)	Margin (dB)	Limit (dBµV/m)
38.271450	23.5	15000.000	120.000	106.0	V	52.0	13.3	6.5	30.0
53.965200	20.7	15000.000	120.000	220.0	V	326.0	13.0	9.3	30.0
95.437200	25.0	15000.000	120.000	98.0	V	299.0	11.3	8.5	33.5
299.137200	31.9	15000.000	120.000	220.0	H	17.0	14.4	4.1	36.0
951.229500	22.6	15000.000	120.000	141.0	V	314.0	25.4	13.4	36.0

Hardware Setup: EMI radiated\Electric Field (NOS) - [EMI radiated]

Subrange 1	
Frequency Range:	30 MHz - 2 GHz
Receiver:	Receiver [ESCI 3] @ GPIB0 (ADR 20), SN 100083/003, FW 4.32
Signal Path:	without Notch FW 1.0
Antenna:	VULB 9163 SN 9163-295, FW --- Correction Table (vertical): VULP6113 Correction Table (horizontal): VULP6113 Correction Table: Cable_EN_1GHz (0909)
Antenna Tower:	Tower [EMCO 2090 Antenna Tower] @ GPIB0 (ADR 8), FW REV 3.12
Turntable:	Turntable [EMCO Turntable] @ GPIB0 (ADR 9), FW REV 3.12
EMC 32 Version 8.10.00	

Plot 2: 1 - 12 GHz, antenna vertical/horizontal (lowest channel) @ 3 m

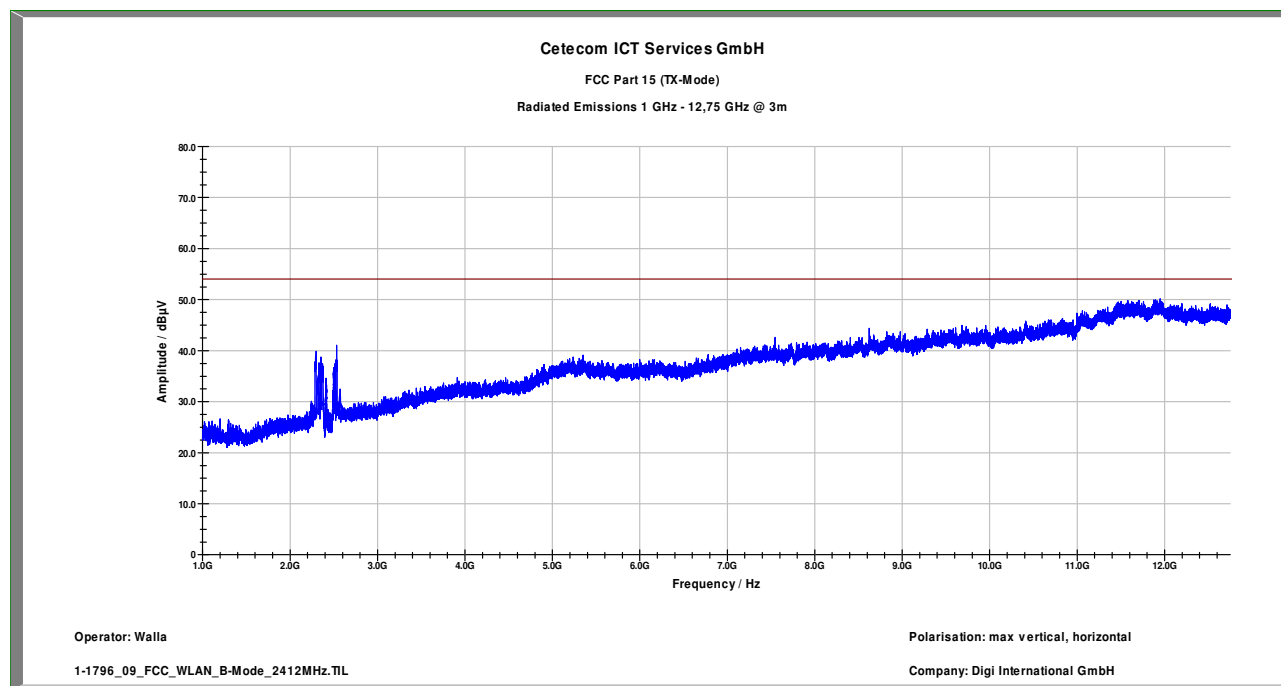

Signal suppressed by a 2.4 GHz band-reject filter

Plot 3: 12- 25 GHz, antenna vertical/horizontal (valid for all channels)

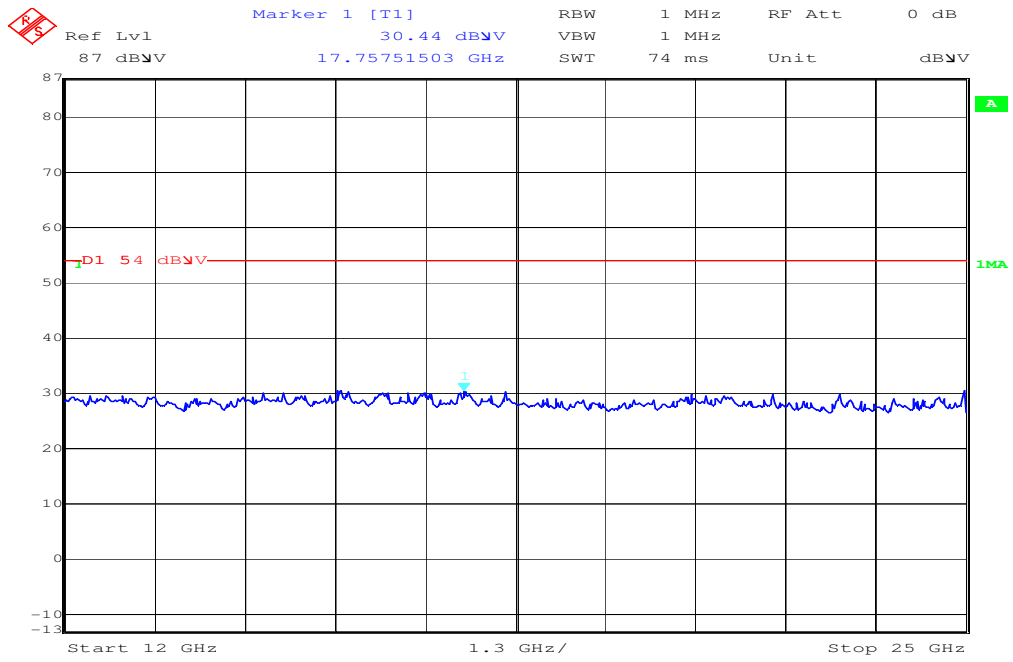

Plot 4: 0.03 - 1 GHz, antenna vertical/horizontal (middle channel) @ 10 m

Information

EUT:	50001589-XX + AC/DC Adaptor
Serial Number:	Prototype + 24000093
Test Description:	FCC Part 15
Operating Conditions:	WLAN test mode B, channel 6
Operator Name:	Kraus
Comment:	Powered with 115V / 60Hz

Scan Setup: STAN_Fin [EMI radiated]

Hardware Setup:	Electric Field (NOS)
Level Unit:	dB μ V/m

Subrange	Detectors	IF Bandwidth	Meas. Time	Receiver
30 MHz - 1,05 GHz	QuasiPeak	120 kHz	15 s	Receiver

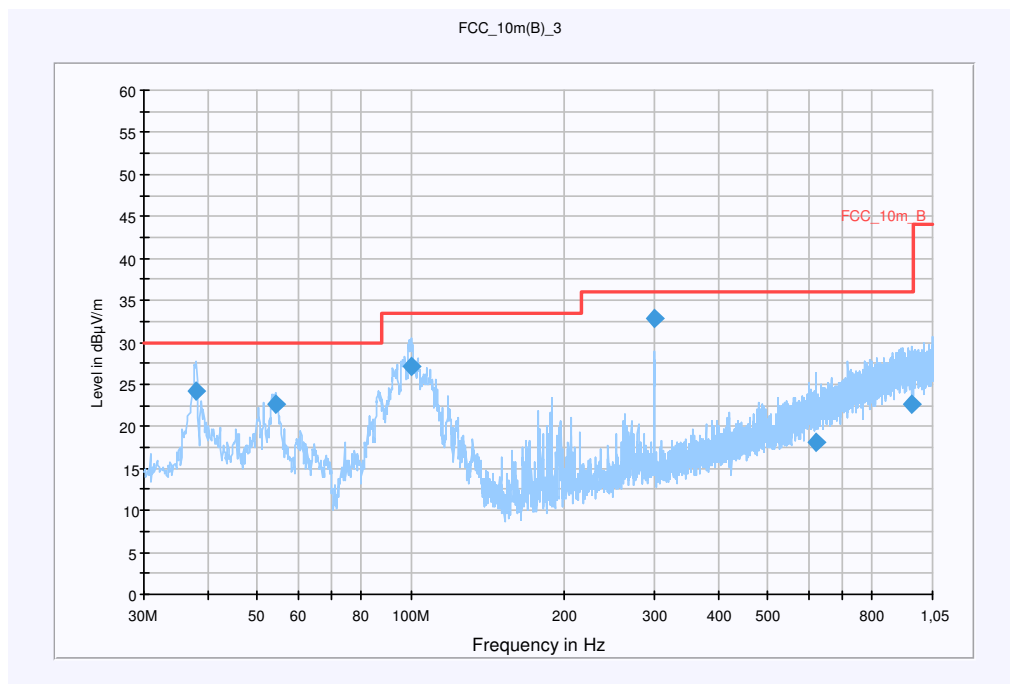

Frequency (MHz)	QuasiPeak (dB μ V/m)	Meas. Time (ms)	Bandwidth (kHz)	Antenna height (cm)	Polarity	Turntable position (deg)	Corr. (dB)	Margin (dB)	Limit (dB μ V/m)
37.913250	24.2	15000.000	120.000	98.0	V	81.0	13.3	5.8	30.0
54.373650	22.6	15000.000	120.000	220.0	V	295.0	12.9	7.4	30.0
100.550100	27.2	15000.000	120.000	98.0	V	8.0	11.8	6.3	33.5
299.160450	32.8	15000.000	120.000	220.0	H	184.0	14.4	3.2	36.0
622.358400	18.1	15000.000	120.000	220.0	V	189.0	20.9	17.9	36.0
953.626200	22.7	15000.000	120.000	220.0	H	137.0	25.4	13.3	36.0

Hardware Setup: EMI radiated\Electric Field (NOS) - [EMI radiated]

Subrange 1	
Frequency Range:	30 MHz - 2 GHz
Receiver:	Receiver [ESCI 3] @ GPIB0 (ADR 20), SN 100083/003, FW 4.32
Signal Path:	without Notch FW 1.0
Antenna:	VULB 9163 SN 9163-295, FW --- Correction Table (vertical): VULP6113 Correction Table (horizontal): VULP6113 Correction Table: Cable_EN_1GHz (0909)
Antenna Tower:	Tower [EMCO 2090 Antenna Tower] @ GPIB0 (ADR 8), FW REV 3.12
Turntable:	Turntable [EMCO Turntable] @ GPIB0 (ADR 9), FW REV 3.12
EMC 32 Version 8.10.00	

Plot 5: 1 - 12 GHz, antenna vertical/horizontal (middle channel) @ 3 m

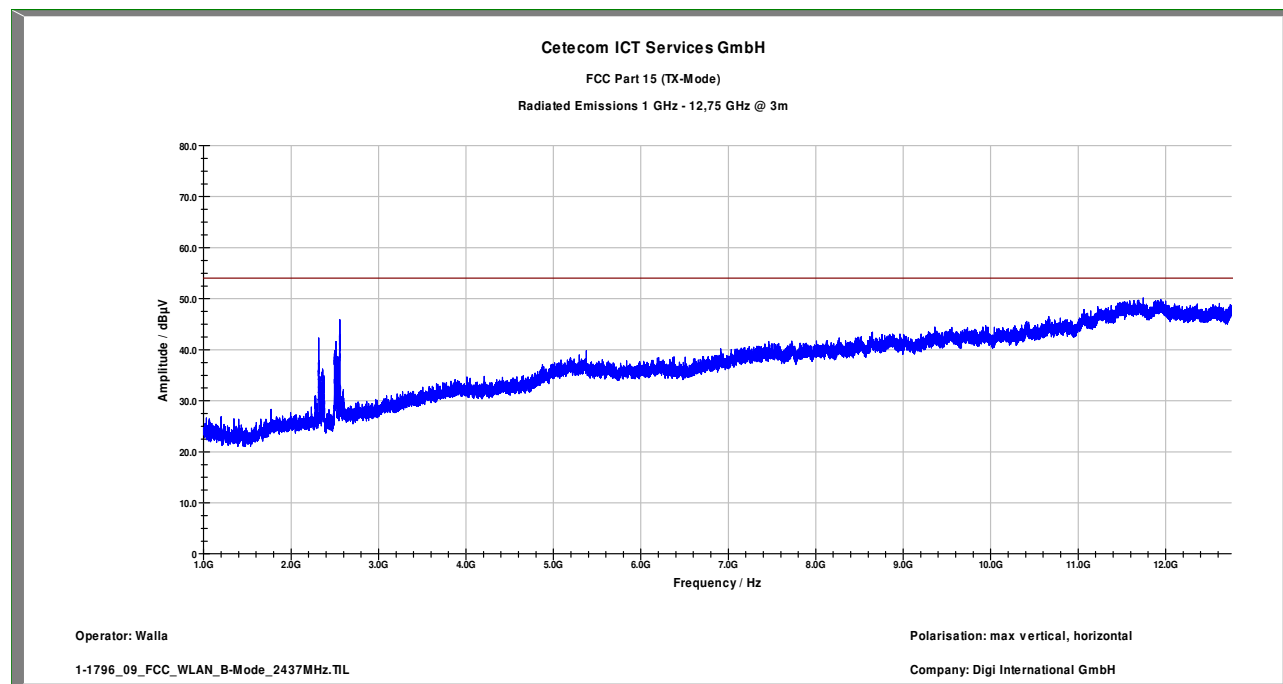

Signal suppressed by a 2.4 GHz band-reject filter

Plot 6: 0.03 - 1 GHz, antenna vertical/horizontal (highest channel)

Information

EUT:	50001589-XX + AC/DC Adaptor
Serial Number:	Prototype + 24000093
Test Description:	FCC Part 15
Operating Conditions:	WLAN test mode B, channel 11
Operator Name:	Kraus
Comment:	Powered with 115V / 60Hz

Scan Setup: STAN_Fin [EMI radiated]

Hardware Setup:	Electric Field (NOS)
Level Unit:	dB μ V/m

Subrange	Detectors	IF Bandwidth	Meas. Time	Receiver
30 MHz - 1,05 GHz	QuasiPeak	120 kHz	15 s	Receiver

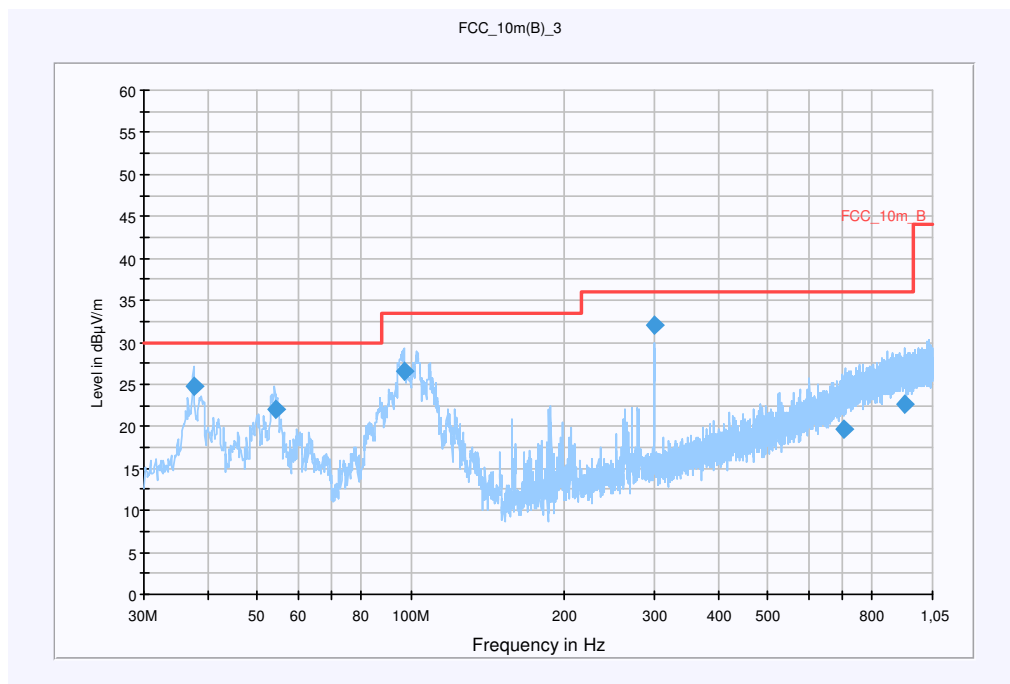

Frequency (MHz)	QuasiPeak (dB μ V/m)	Meas. Time (ms)	Bandwidth (kHz)	Antenna height (cm)	Polarity	Turntable position (deg)	Corr. (dB)	Margin (dB)	Limit (dB μ V/m)
37.786350	24.7	15000.000	120.000	98.0	V	86.0	13.3	5.3	30.0
54.408450	22.0	15000.000	120.000	186.0	V	14.0	12.9	8.0	30.0
97.206600	26.6	15000.000	120.000	124.0	V	-4.0	11.5	6.9	33.5
299.163000	32.0	15000.000	120.000	220.0	H	8.0	14.4	4.0	36.0
706.667700	19.8	15000.000	120.000	220.0	H	253.0	22.6	16.2	36.0
928.348800	22.5	15000.000	120.000	131.0	H	236.0	25.3	13.5	36.0

Hardware Setup: EMI radiated\Electric Field (NOS) - [EMI radiated]

Subrange 1	
Frequency Range:	30 MHz - 2 GHz
Receiver:	Receiver [ESCI 3] @ GPIB0 (ADR 20), SN 100083/003, FW 4.32
Signal Path:	without Notch FW 1.0
Antenna:	VULB 9163 SN 9163-295, FW --- Correction Table (vertical): VULP6113 Correction Table (horizontal): VULP6113 Correction Table: Cable_EN_1GHz (0909)
Antenna Tower:	Tower [EMCO 2090 Antenna Tower] @ GPIB0 (ADR 8), FW REV 3.12
Turntable:	Turntable [EMCO Turntable] @ GPIB0 (ADR 9), FW REV 3.12
EMC 32 Version 8.10.00	

Plot 7: 1 - 12 GHz, antenna vertical/horizontal (highest channel)

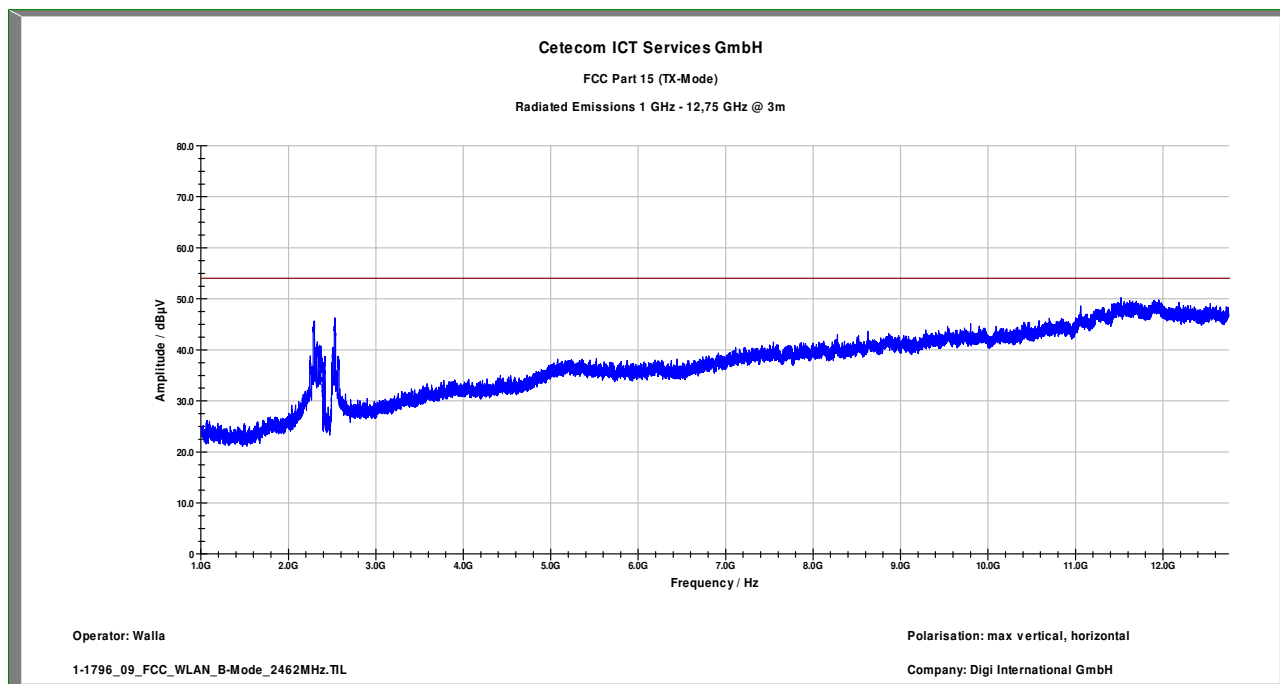

Signal suppressed by a 2.4 GHz band-reject filter

OFDM:

Plot 8: 0.03 - 1 GHz, antenna vertical/horizontal (lowest channel) @ 10 m

Information

EUT:	50001589-XX + AC/DC Adaptor
Serial Number:	Prototype + 24000093
Test Description:	FCC Part 15
Operating Conditions:	WLAN test mode G, channel 1
Operator Name:	Kraus
Comment:	Powered with 115V / 60Hz

Scan Setup: STAN_Fin [EMI radiated]

Hardware Setup:	Electric Field (NOS)
Level Unit:	dBµV/m

Subrange	Detectors	IF Bandwidth	Meas. Time	Receiver
30 MHz - 1,05 GHz	QuasiPeak	120 kHz	15 s	Receiver

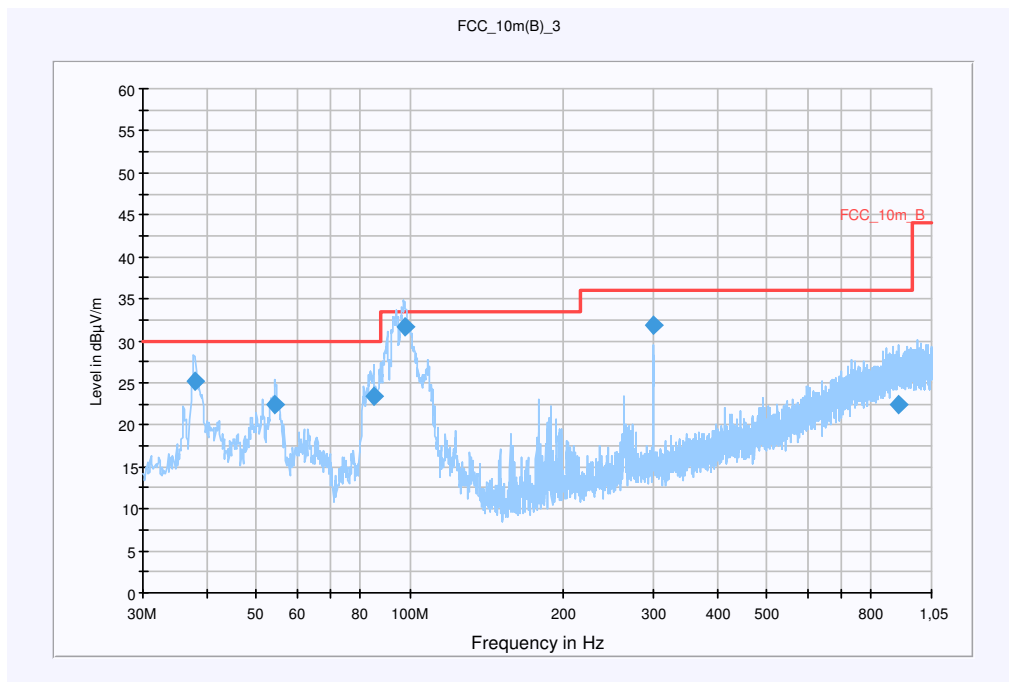

Frequency (MHz)	QuasiPeak (dBµV/m)	Meas. Time (ms)	Bandwidth (kHz)	Antenna height (cm)	Polarity	Turntable position (deg)	Corr. (dB)	Margin (dB)	Limit (dBµV/m)
37.853400	25.1	15000.000	120.000	98.0	V	21.0	13.3	4.9	30.0
54.542250	22.4	15000.000	120.000	220.0	V	325.0	12.9	7.6	30.0
85.313550	23.3	15000.000	120.000	122.0	V	222.0	9.9	6.7	30.0
97.704600	31.6	15000.000	120.000	109.0	V	285.0	11.6	1.9	33.5
299.180100	31.9	15000.000	120.000	220.0	H	160.0	14.4	4.1	36.0
904.015650	22.5	15000.000	120.000	220.0	V	91.0	25.2	13.5	36.0

Hardware Setup: EMI radiated\Electric Field (NOS) - [EMI radiated]

Subrange 1	
Frequency Range:	30 MHz - 2 GHz
Receiver:	Receiver [ESCI 3] @ GPIB0 (ADR 20), SN 100083/003, FW 4.32
Signal Path:	without Notch FW 1.0
Antenna:	VULB 9163 SN 9163-295, FW --- Correction Table (vertical): VULP6113 Correction Table (horizontal): VULP6113 Correction Table: Cable_EN_1GHz (0909)
Antenna Tower:	Tower [EMCO 2090 Antenna Tower] @ GPIB0 (ADR 8), FW REV 3.12
Turntable:	Turntable [EMCO Turntable] @ GPIB0 (ADR 9), FW REV 3.12
EMC 32 Version 8.10.00	

Plot 9: 1 - 12 GHz, antenna vertical/horizontal (lowest channel) @ 3 m

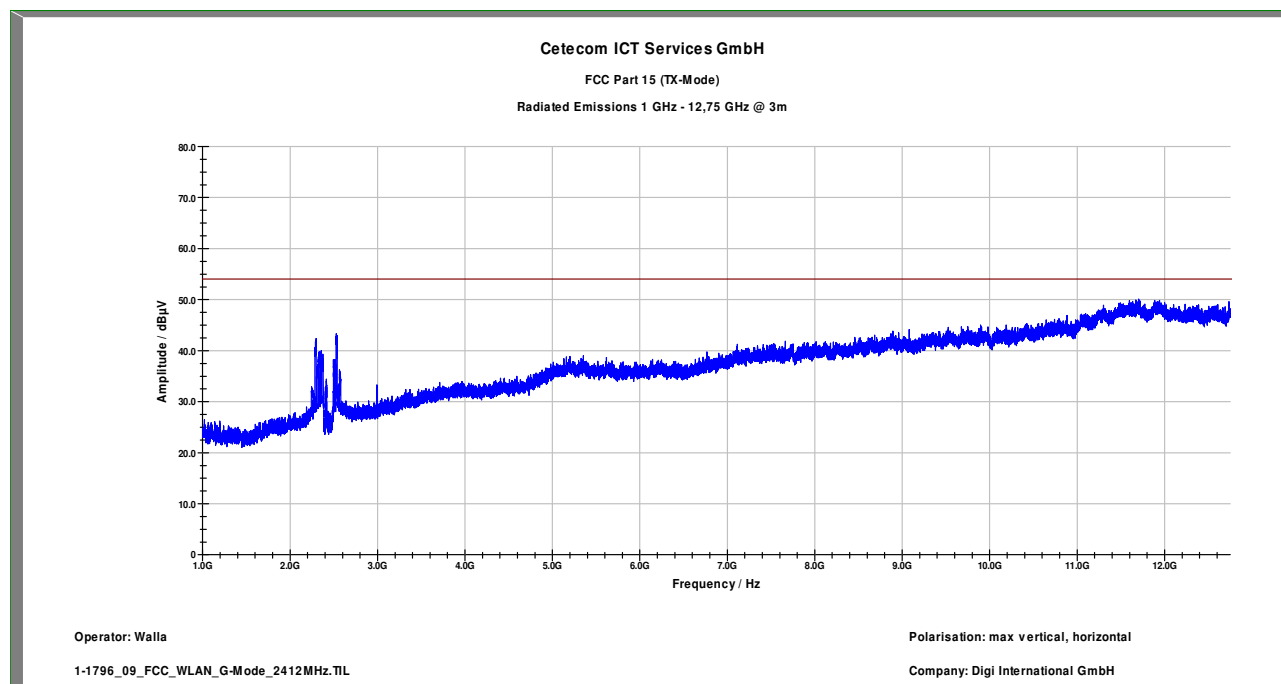

Signal suppressed by a 2.4 GHz band-reject filter

Plot 10: 12- 25 GHz, antenna vertical/horizontal (valid for all channels)

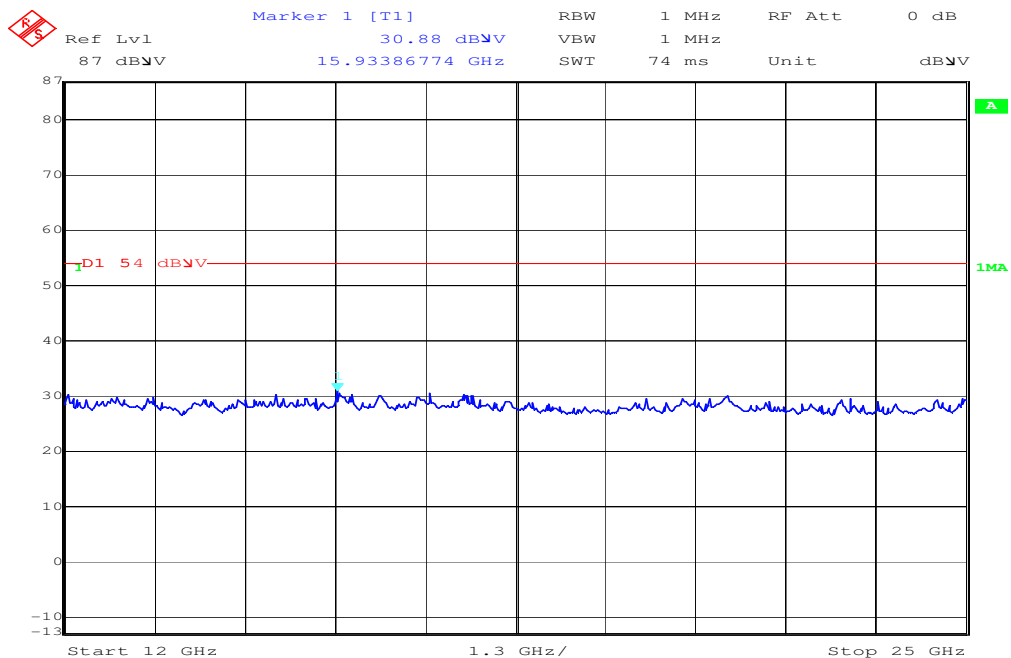

Plot 11: 0.03 - 1 GHz, antenna vertical/horizontal (middle channel) @ 10 m

Information

EUT:	50001589-XX + AC/DC Adaptor
Serial Number:	Prototype + 24000093
Test Description:	FCC Part 15
Operating Conditions:	WLAN test mode G, channel 6
Operator Name:	Kraus
Comment:	Powered with 115V / 60Hz

Scan Setup: STAN_Fin [EMI radiated]

Hardware Setup:	Electric Field (NOS)
Level Unit:	dB μ V/m

Subrange	Detectors	IF Bandwidth	Meas. Time	Receiver
30 MHz - 1,05 GHz	QuasiPeak	120 kHz	15 s	Receiver

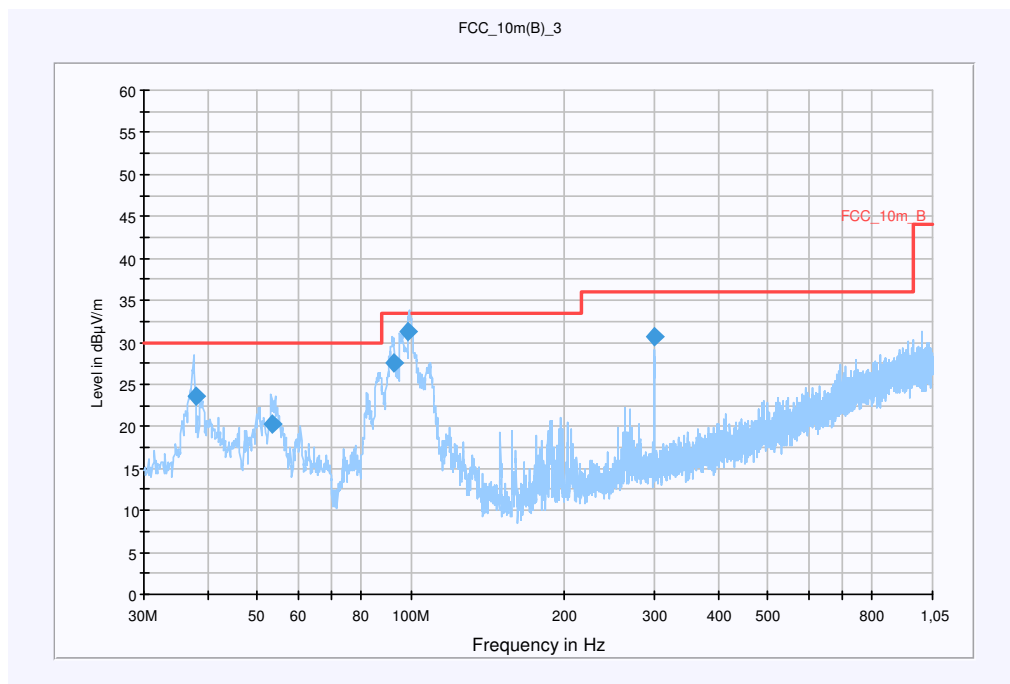

Frequency (MHz)	QuasiPeak (dB μ V/m)	Meas. Time (ms)	Bandwidth (kHz)	Antenna height (cm)	Polarity	Turntable position (deg)	Corr. (dB)	Margin (dB)	Limit (dB μ V/m)
37.824150	23.7	15000.000	120.000	115.0	V	32.0	13.3	6.3	30.0
53.481300	20.2	15000.000	120.000	98.0	V	15.0	13.0	9.8	30.0
92.385300	27.5	15000.000	120.000	120.0	V	277.0	10.9	6.0	33.5
98.532000	31.2	15000.000	120.000	98.0	V	294.0	11.7	2.3	33.5
300.475800	30.8	15000.000	120.000	220.0	H	4.0	14.4	5.2	36.0

Hardware Setup: EMI radiated\Electric Field (NOS) - [EMI radiated]

Subrange 1	
Frequency Range:	30 MHz - 2 GHz
Receiver:	Receiver [ESCI 3] @ GPIB0 (ADR 20), SN 100083/003, FW 4.32
Signal Path:	without Notch FW 1.0
Antenna:	VULB 9163 SN 9163-295, FW --- Correction Table (vertical): VULP6113 Correction Table (horizontal): VULP6113 Correction Table: Cable_EN_1GHz (0909)
Antenna Tower:	Tower [EMCO 2090 Antenna Tower] @ GPIB0 (ADR 8), FW REV 3.12
Turntable:	Turntable [EMCO Turntable] @ GPIB0 (ADR 9), FW REV 3.12
EMC 32 Version 8.10.00	

Plot 12: 1 - 12 GHz, antenna vertical/horizontal (middle channel) @ 3 m

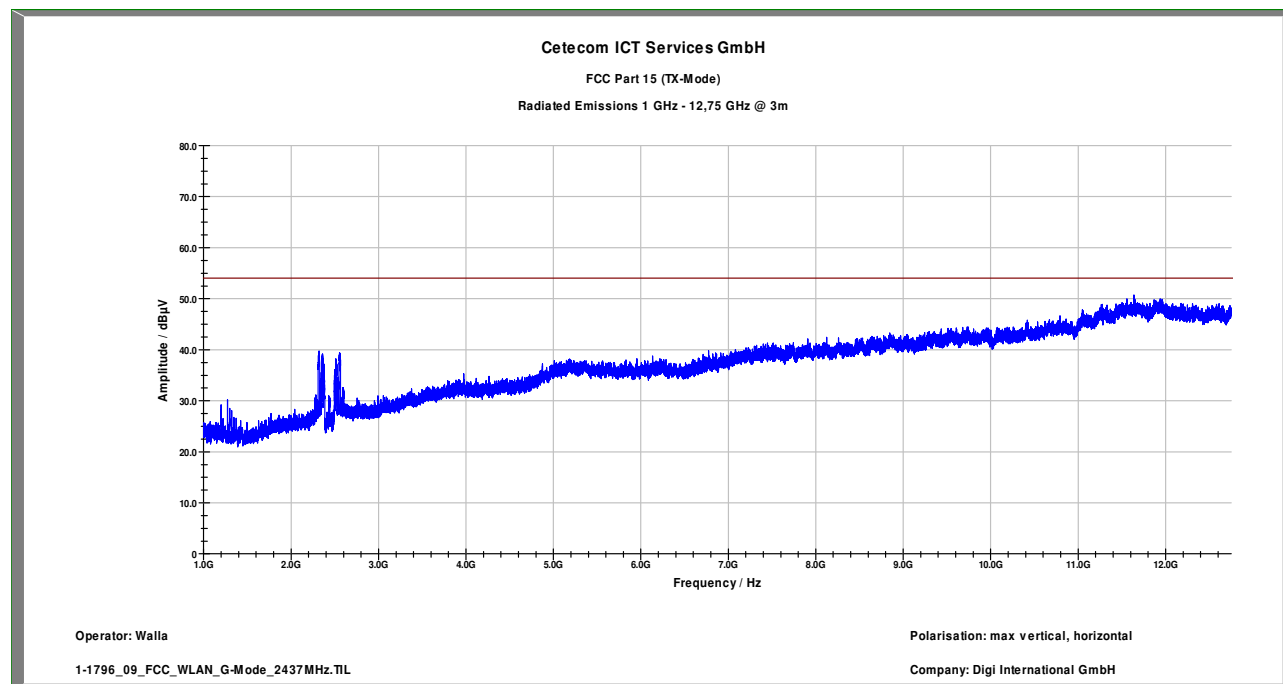

Signal suppressed by a 2.4 GHz band-reject filter

Plot 13: 0.03 - 1 GHz, antenna vertical/horizontal (highest channel)

Information

EUT:	DVT ConnectCore Wi 9P 9215 W-LAN + AC/DC Adaptor
Serial Number:	Prototype + 24000093
Test Description:	FCC Part 15
Operating Conditions:	WLAN test mode G, channel 11
Operator Name:	Kraus
Comment:	Powered with 115V / 60Hz

Scan Setup: STAN_Fin [EMI radiated]

Hardware Setup:	Electric Field (NOS)
Level Unit:	dB μ V/m

Subrange	Detectors	IF Bandwidth	Meas. Time	Receiver
30 MHz - 1,05 GHz	QuasiPeak	120 kHz	15 s	Receiver

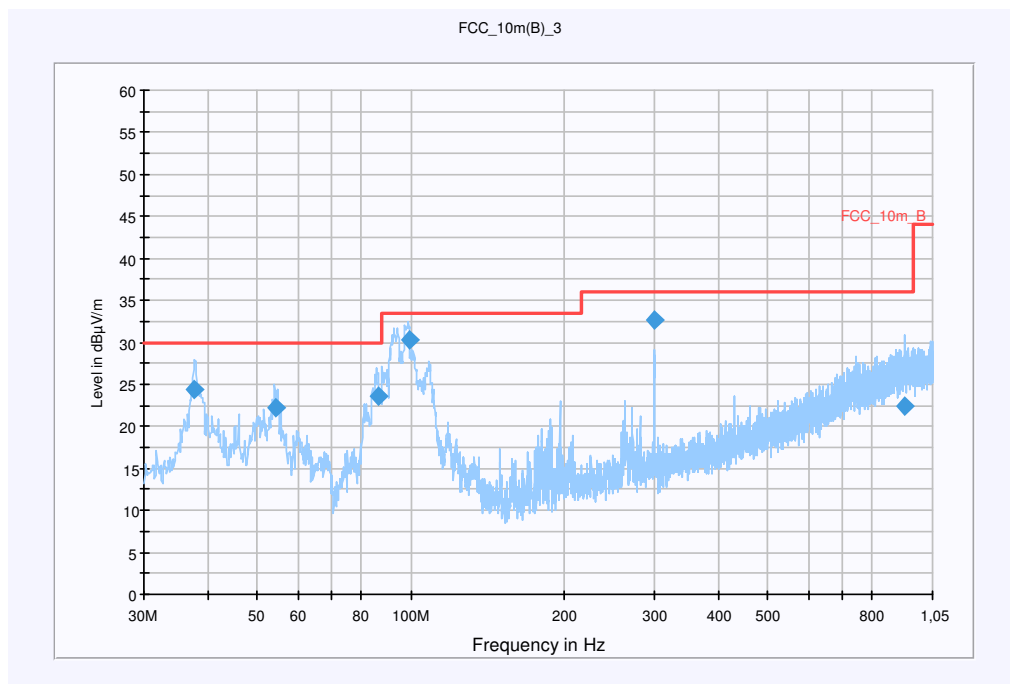

Frequency (MHz)	QuasiPeak (dB μ V/m)	Meas. Time (ms)	Bandwidth (kHz)	Antenna height (cm)	Polarity	Turntable position (deg)	Corr. (dB)	Margin (dB)	Limit (dB μ V/m)
37.628400	24.3	15000.000	120.000	165.0	V	77.0	13.2	5.7	30.0
54.300450	22.1	15000.000	120.000	220.0	V	281.0	13.0	7.9	30.0
86.416650	23.6	15000.000	120.000	142.0	V	212.0	10.0	6.4	30.0
99.186150	30.3	15000.000	120.000	98.0	V	236.0	11.8	3.2	33.5
299.155350	32.6	15000.000	120.000	220.0	H	182.0	14.4	3.4	36.0
928.761150	22.5	15000.000	120.000	108.0	H	71.0	25.3	13.5	36.0

Hardware Setup: EMI radiated\Electric Field (NOS) - [EMI radiated]

Subrange 1	
Frequency Range:	30 MHz - 2 GHz
Receiver:	Receiver [ESCI 3] @ GPIB0 (ADR 20), SN 100083/003, FW 4.32
Signal Path:	without Notch FW 1.0
Antenna:	VULB 9163 SN 9163-295, FW --- Correction Table (vertical): VULP6113 Correction Table (horizontal): VULP6113 Correction Table: Cable_EN_1GHz (0909)
Antenna Tower:	Tower [EMCO 2090 Antenna Tower] @ GPIB0 (ADR 8), FW REV 3.12
Turntable:	Turntable [EMCO Turntable] @ GPIB0 (ADR 9), FW REV 3.12
EMC 32 Version 8.10.00	

Plot 14: 1 - 12 GHz, antenna vertical/horizontal (highest channel)

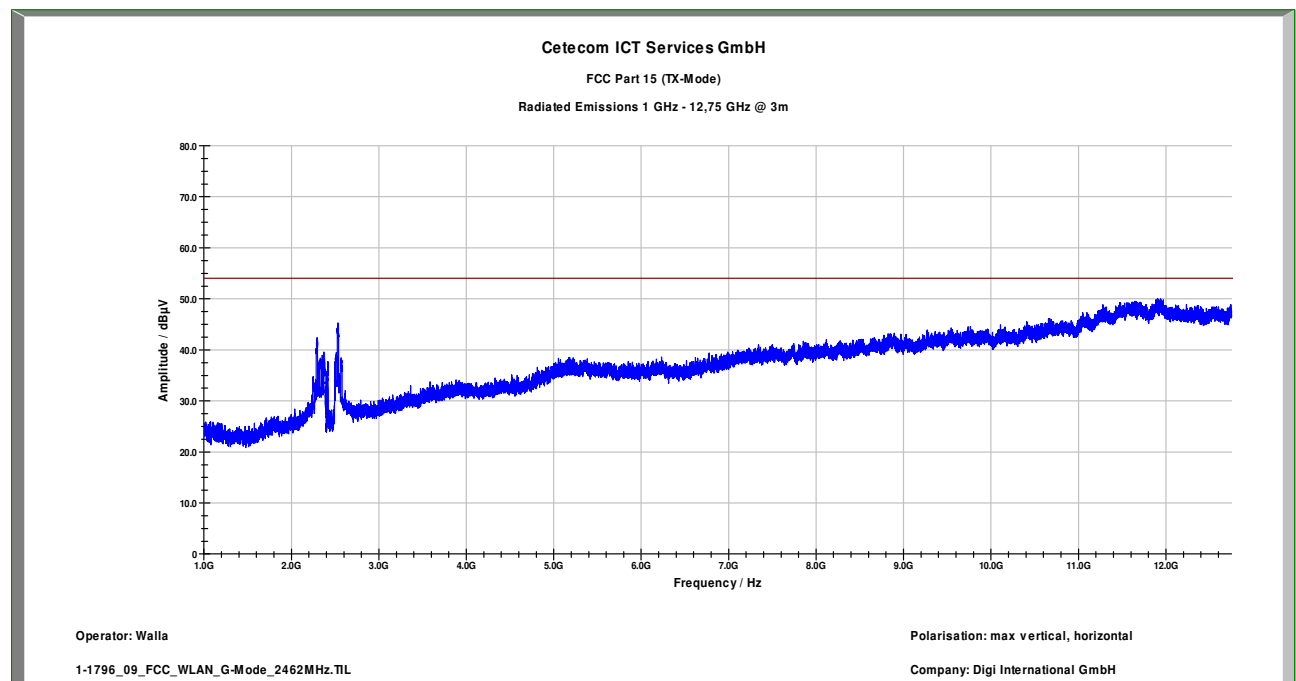

Signal suppressed by a 2.4 GHz band-reject filter

Results:

SPURIOUS EMISSIONS LEVEL §15.209								
2412 MHz			2437 MHz			2462 MHz		
Frequency [MHz]	Detector	Level [dBµV/m]	Frequency [MHz]	Detector	Level [dBµV/m]	Frequency [MHz]	Detector	Level [dBµV/m]
No critical Peaks detected!			No critical Peaks detected!			No critical Peaks detected!		
Measurement uncertainty			±3 dB					

f < 1 GHz : RBW/VBW: 100 kHz

f ≥ 1GHz : RBW/VBW: 1 MHz

Limits:

§ 15.247 (c)

In any 100 kHz bandwidth outside the frequency band at least 20dB below the highest level of the desired power. In addition, radiated emissions which fall in the restricted bands, as defined in §15.205(a), must also comply with the radiated emission limits specified in §15.209(a) (see §15.205(c)).

Limits:

§ 15.109

Frequency (MHz)	Field strength (dBµV/m)	Measurement distance (m)
30 - 88	30.0	10
88 - 216	33.5	10
216 - 960	36.0	10
above 960	54.0	3

5.8 Spurious Emissions - radiated (Receiver) §15.109 / 209

Plot 15: 0.03 - 1 GHz, antenna vertical/horizontal (receiver) @ 10m

Information

EUT:	50001589-XX + AC/DC Adaptor
Serial Number:	Prototype + 24000093
Test Description:	FCC Part 15
Operating Conditions:	WLAN RX-Mode
Operator Name:	Kraus
Comment:	Powered with 115V / 60Hz

Scan Setup: STAN_Fin [EMI radiated]

Hardware Setup:	Electric Field (NOS)
Level Unit:	dBµV/m

Subrange	Detectors	IF Bandwidth	Meas. Time	Receiver
30 MHz - 1,05 GHz	QuasiPeak	120 kHz	15 s	Receiver

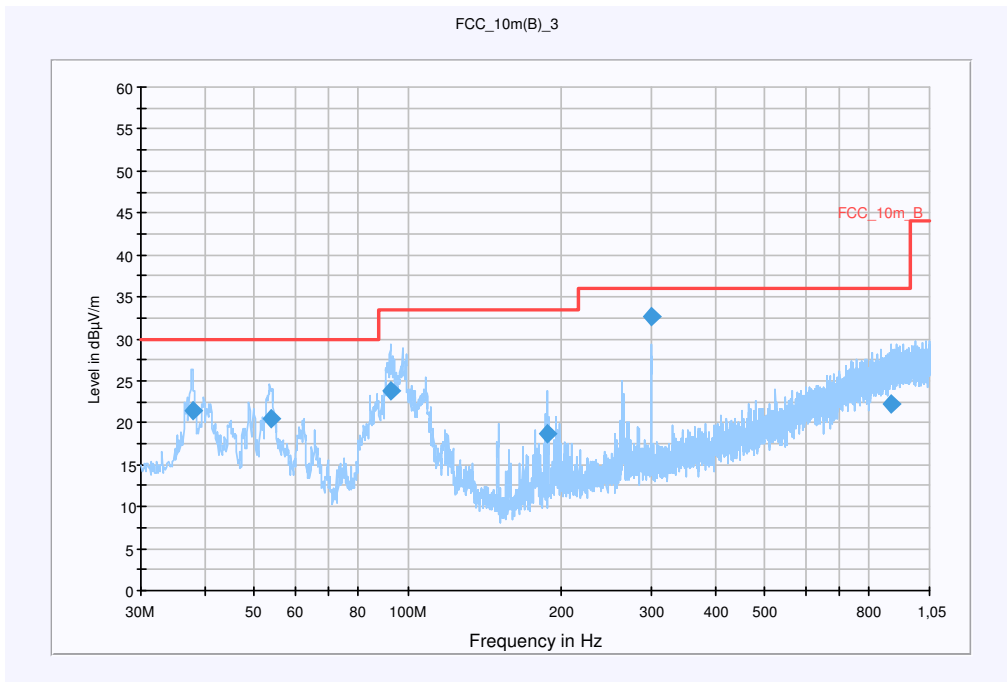

Frequency (MHz)	QuasiPeak (dBµV/m)	Meas. Time (ms)	Bandwidth (kHz)	Antenna height (cm)	Polarity	Turntable position (deg)	Corr. (dB)	Margin (dB)	Limit (dBµV/m)
37.838250	21.5	15000.000	120.000	125.0	V	52.0	13.3	8.5	30.0
53.781900	20.5	15000.000	120.000	182.0	V	7.0	13.0	9.5	30.0
92.307600	23.8	15000.000	120.000	115.0	V	297.0	10.9	9.7	33.5
187.131000	18.7	15000.000	120.000	98.0	V	206.0	10.8	14.8	33.5
299.164950	32.6	15000.000	120.000	220.0	H	184.0	14.4	3.4	36.0
882.904050	22.3	15000.000	120.000	220.0	H	261.0	25.0	13.7	36.0

Hardware Setup: EMI radiated\Electric Field (NOS) - [EMI radiated]

Subrange 1	
Frequency Range:	30 MHz - 2 GHz
Receiver:	Receiver [ESCI 3] @ GPIB0 (ADR 20), SN 100083/003, FW 4.32
Signal Path:	without Notch FW 1.0
Antenna:	VULB 9163 SN 9163-295, FW --- Correction Table (vertical): VULP6113 Correction Table (horizontal): VULP6113 Correction Table: Cable_EN_1GHz (0909)
Antenna Tower:	Tower [EMCO 2090 Antenna Tower] @ GPIB0 (ADR 8), FW REV 3.12
Turntable:	Turntable [EMCO Turntable] @ GPIB0 (ADR 9), FW REV 3.12
EMC 32 Version 8.10.00	

Plot 16: 1 - 12 GHz, antenna vertical/horizontal (receiver) @ 3m

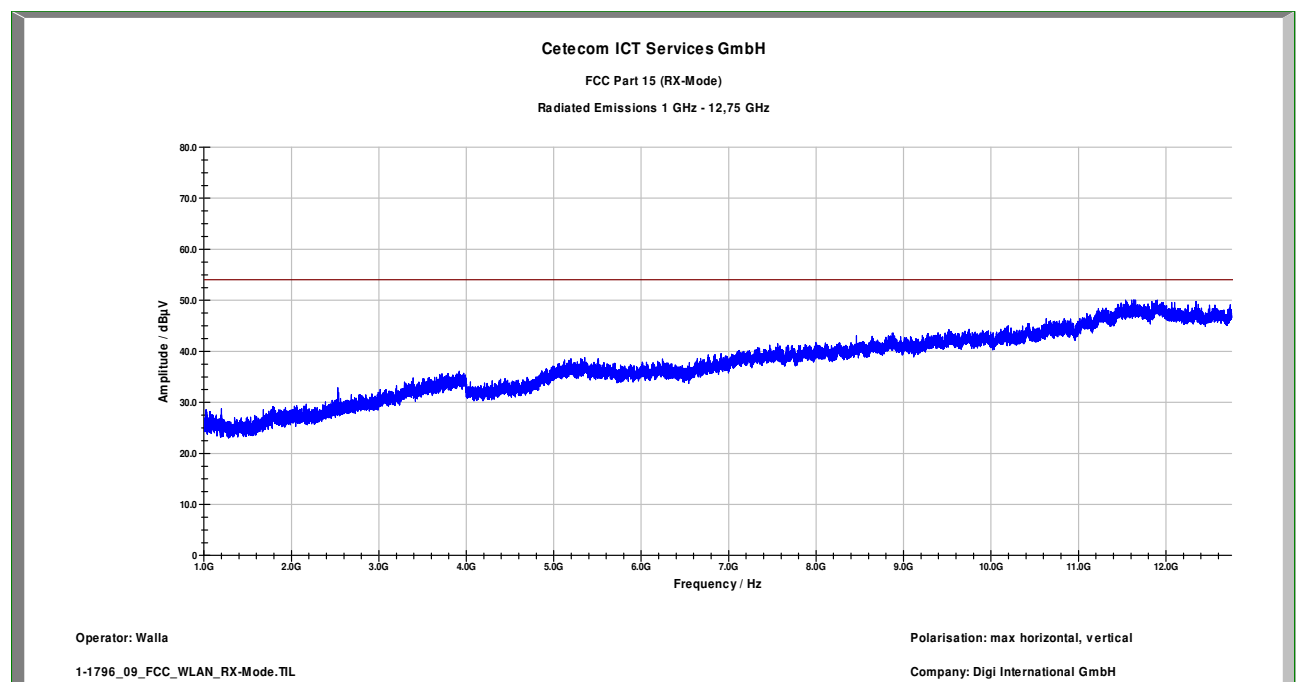

Plot 17: 12- 25 GHz (receiver)

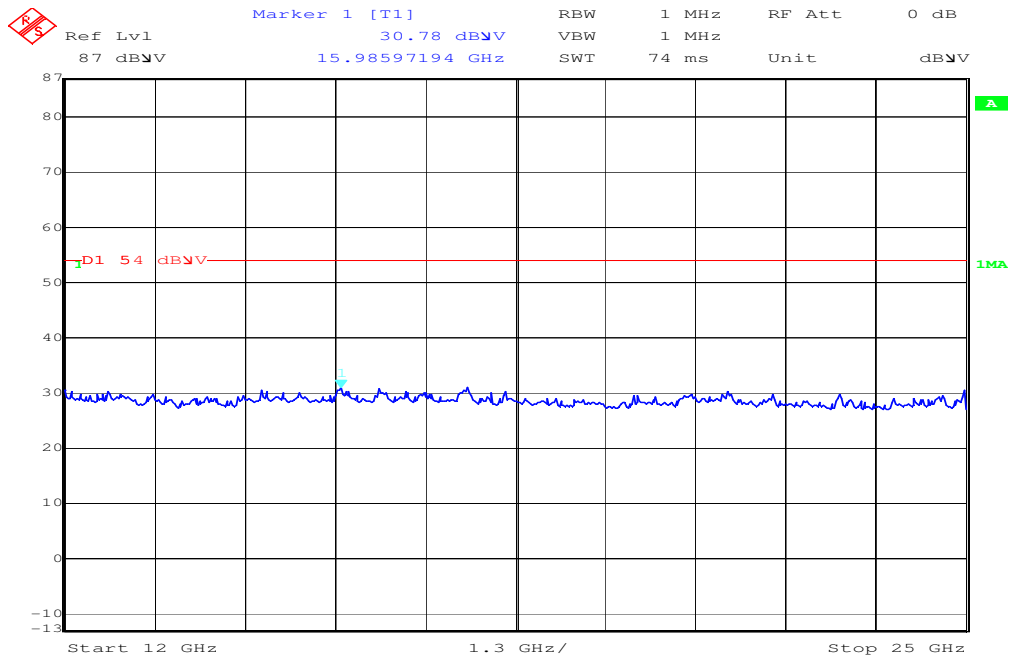

Results:

Spurious Emissions level [dBμV/m]		
Frequency [MHz]	Detector	Level [dBμV/m]
No critical peaks detected!		
Measurement uncertainty		±3 dB

f < 1 GHz : RBW/VBW: 100 kHz f ≥ 1GHz : RBW/VBW: 1 MHz

See above plots

Measurement distance see table

Limits:

§ 15.109

Frequency (MHz)	Field strength (dBμV/m)	Measurement distance (m)
30 - 88	30.0	10
88 - 216	33.5	10
216 - 960	36.0	10
above 960	54.0	3

5.9 Spurious Emissions - radiated <30 MHz §15.209

Measured at 3 m distance.

Values recalculated with 40 dB/decade according to FCC rules.

Plot 18: TX – Mode

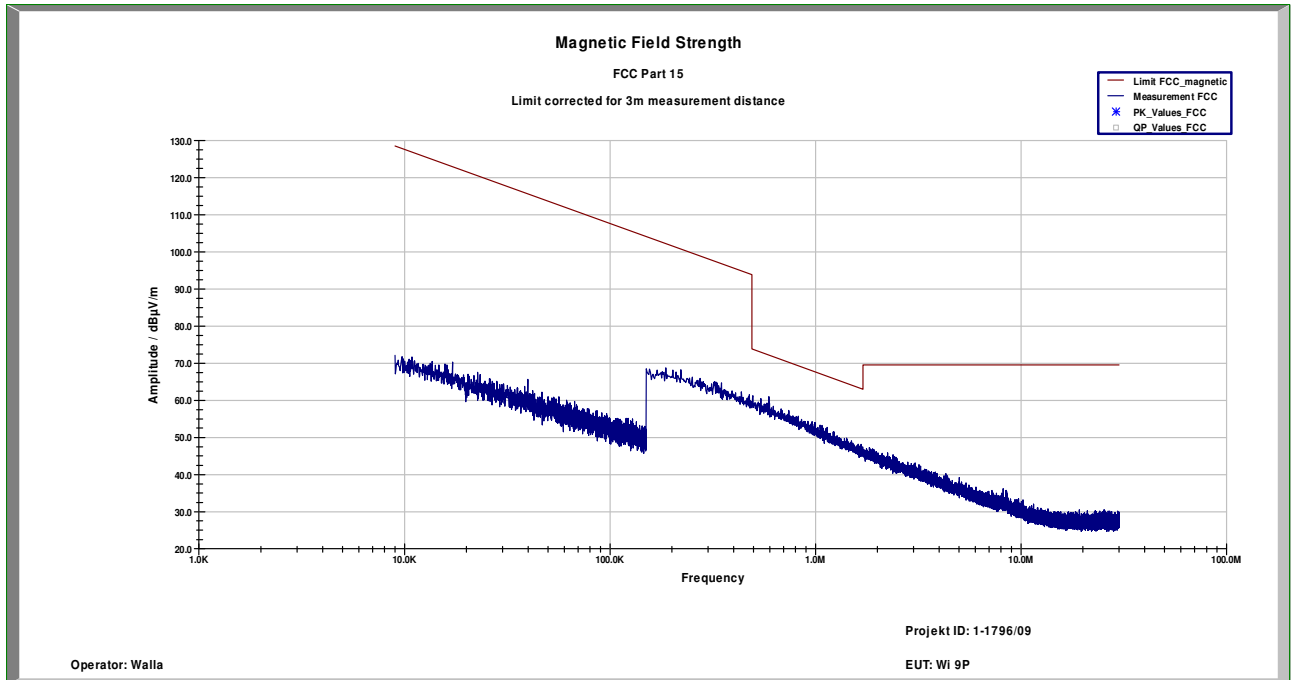

Plot 19: RX – Mode

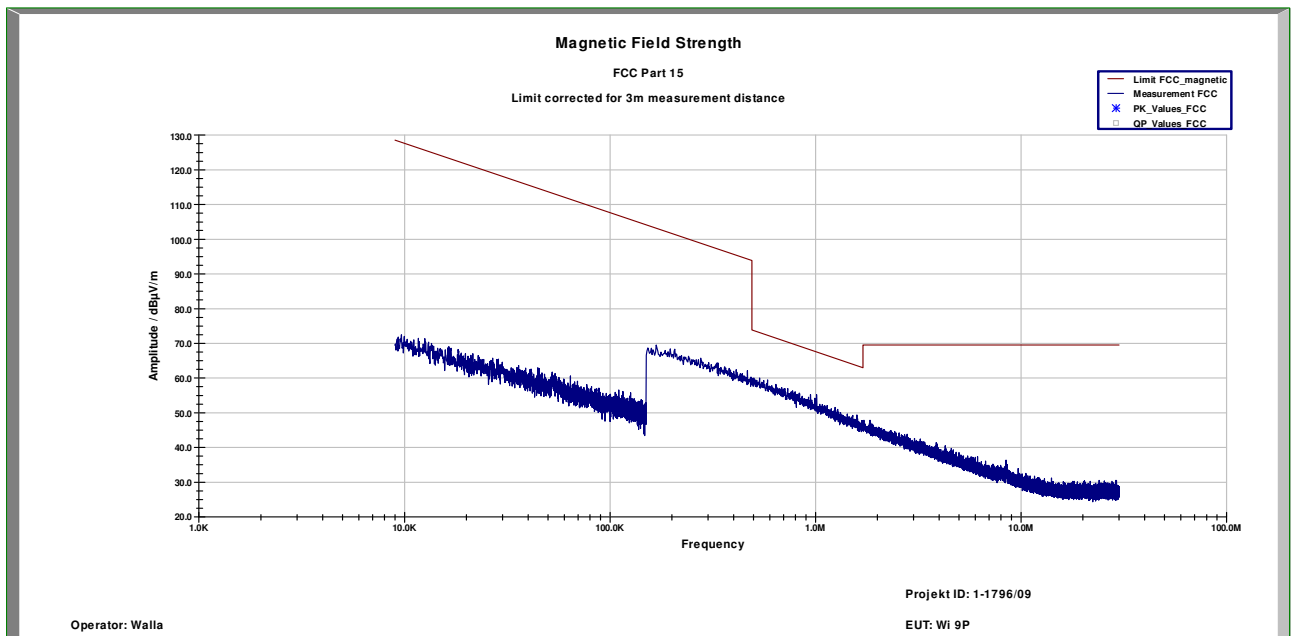

Limits:

Frequency (MHz)	Field strength ($\mu\text{V/m}$)	Measurement distance (m)
0.009 – 0.490	2400/F(kHz)	300
0.490 – 1.705	24000/F(kHz)	30
1.705 – 30.0	30 / 29.5 dB $\mu\text{V/m}$	30
30 - 88	100 / 40 dB $\mu\text{V/m}$	3
88 - 216	150 / 43.5 dB $\mu\text{V/m}$	3
216 - 960	200 / 46 dB $\mu\text{V/m}$	3
above 960	54 dB $\mu\text{V/m}$	3

5.10 Conducted Emissions <30 MHz §15.107/207

DSSS:

Plot 20: TX – Mode, Neutral line

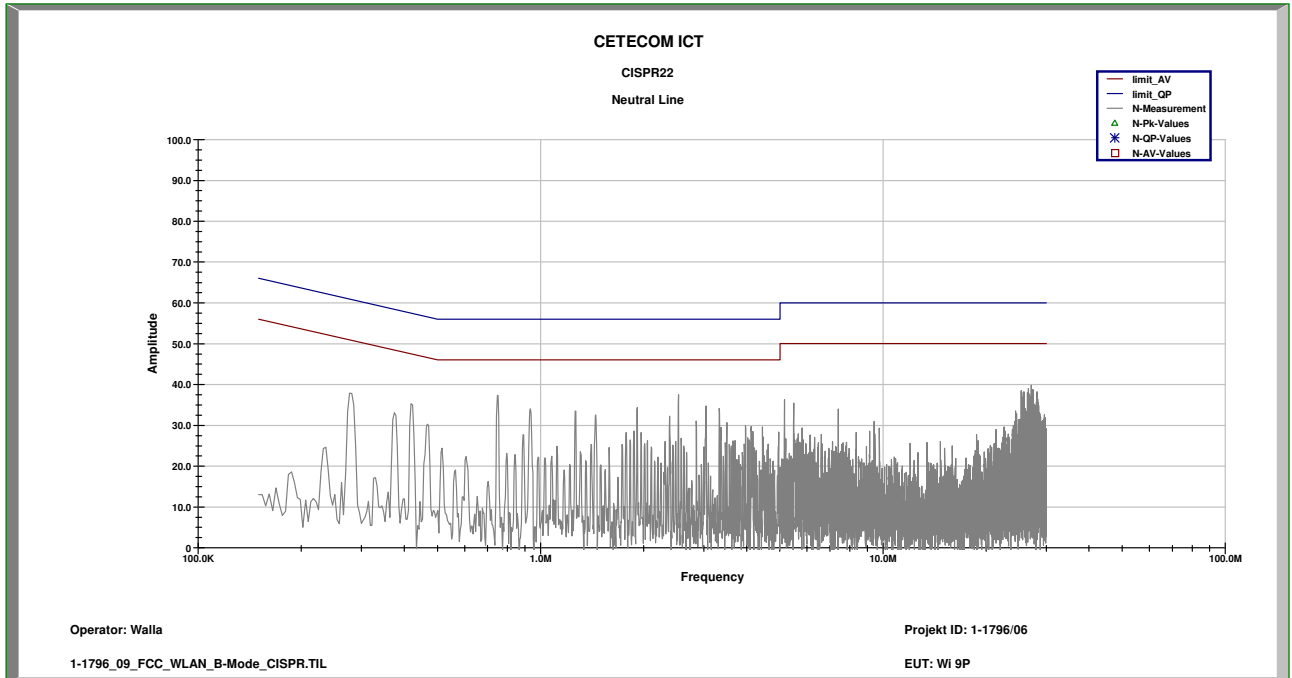

Plot 21: TX – Mode, Phase line

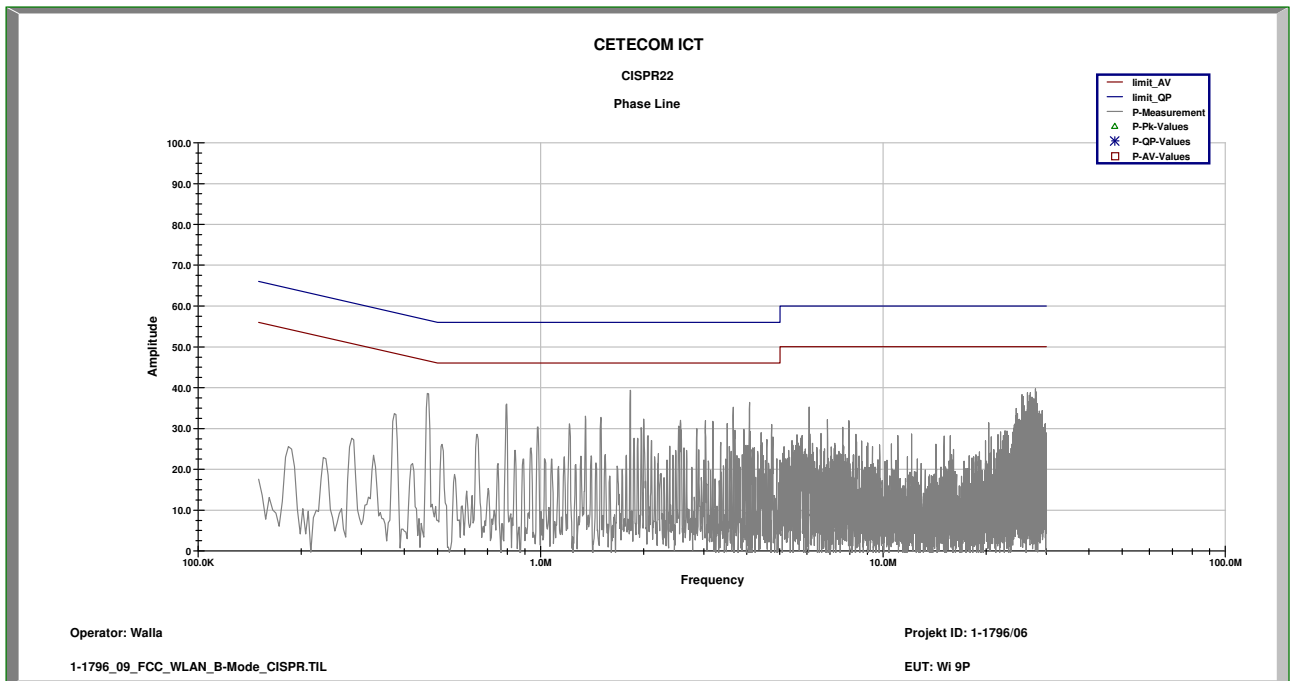

Limits:

Under normal test conditions only	See plots
-----------------------------------	-----------

OFDM:

Plot 22: TX – Mode, Neutral line

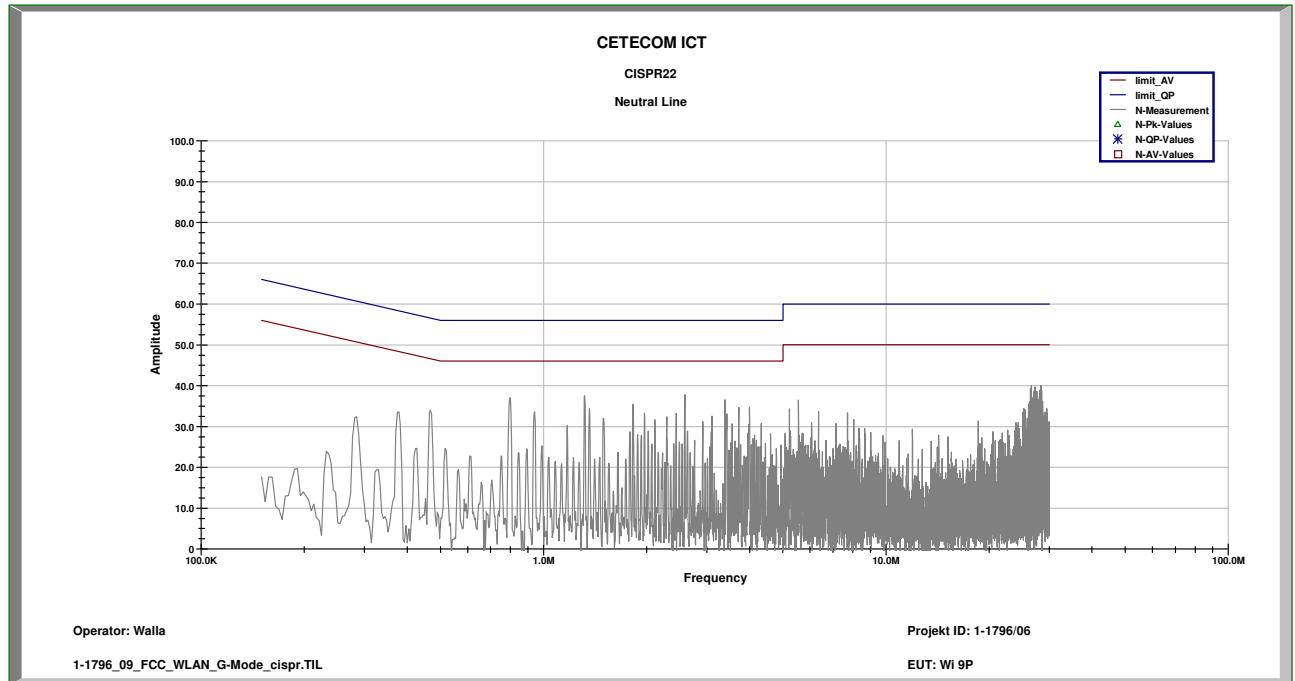

Plot 23: TX – Mode, Phase line

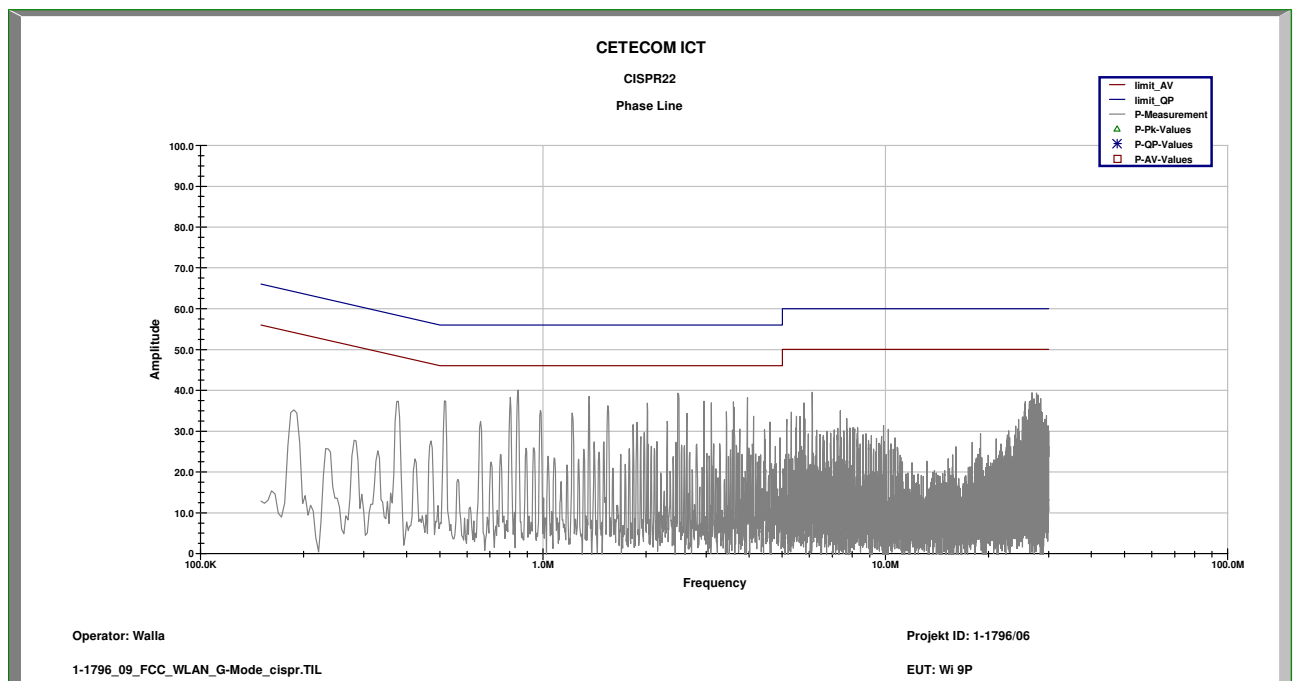

Limits:

Under normal test conditions only	See plots
-----------------------------------	-----------

Plot 24: RX – Mode, Neutral line

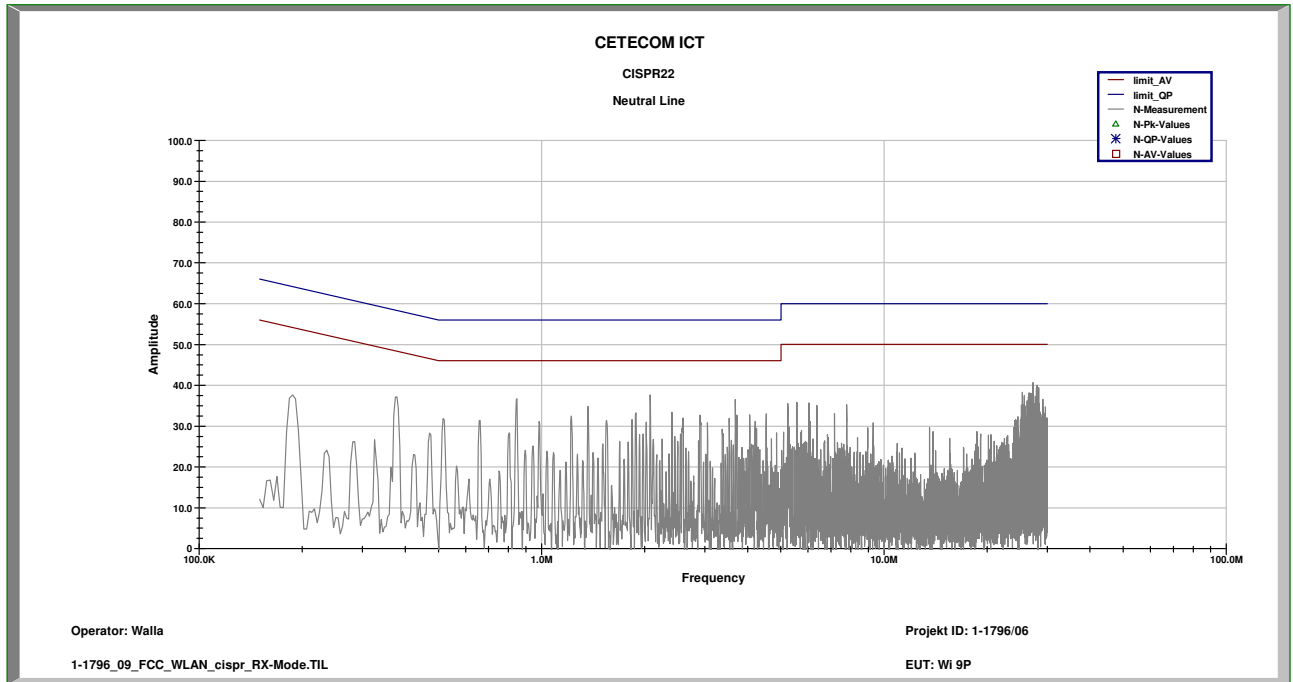

Plot 25: RX – Mode, Phase line

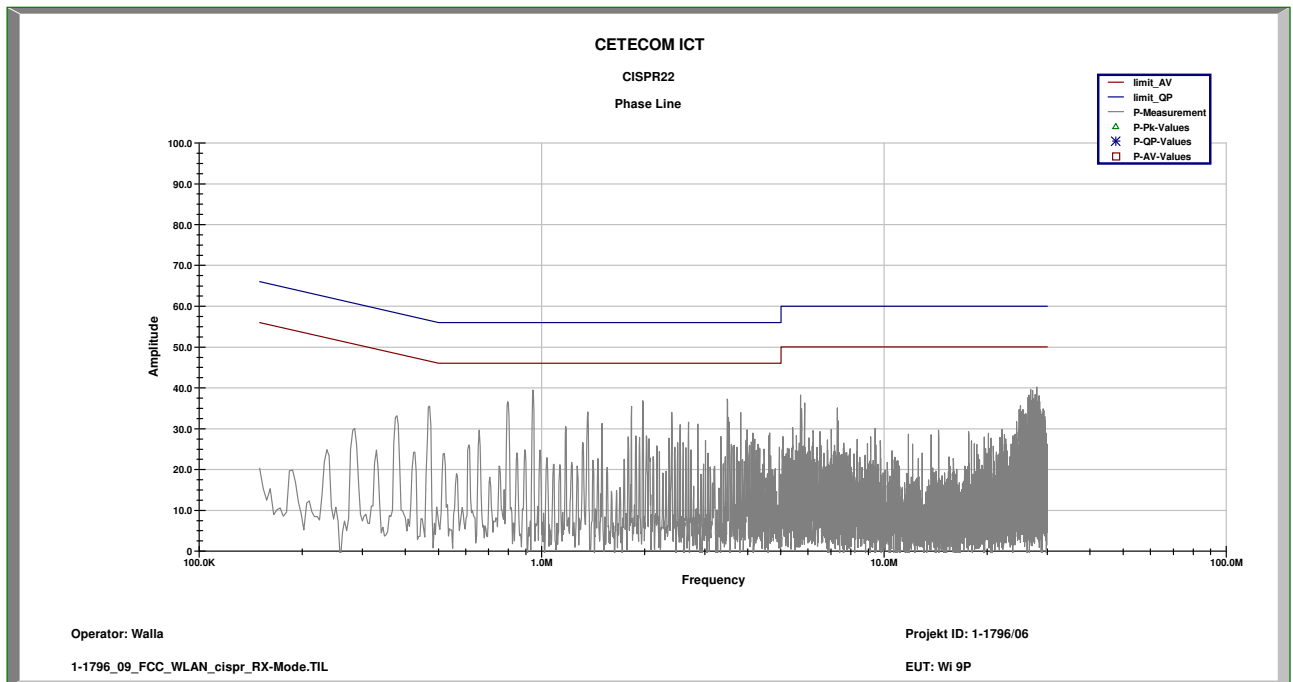

Limits:

Under normal test conditions only	See plots
-----------------------------------	-----------

6 Test equipment and ancillaries used for tests

In order to simplify the identification of the equipment used at each specific test, each item of test equipment and ancillaries are provided with an identifier or number in the equipment list below.

Typically, the calibrations of the test apparatus are commissioned to and performed by an accredited calibration laboratory. The calibration intervals are determined in accordance with the DIN EN ISO/IEC 17025. In addition to the external calibrations, the laboratory executes comparison measurements with other calibrated test systems or effective verifications. Weekly chamber inspections and range calibrations are performed. Where possible, rf-generating and signalling equipment as well as measuring receivers and analyzers are connected to an external high-precision 10 MHz reference (GPS-based or rubidium frequency standard).

No.	Equipment	Type	Manufact.	Serial No.	INV. No Cetecom	Last Calibration	Next Calibration
1	System Autoranging DC power supply, 60Vdc, 50A, 1200 W	6032A	HP Meßtechnik	2818A03450	300001040	08.01.2009	08.01.2012
2	PowerAttenuator	8325	Byrd	1530	300001595		
3	Double-Ridged Waveguide Horn Antenna 1-26.5GHz	3115	EMCO	8812-3088	300001032	05.03.2009	05.03.2011
4	Active Loop Antenna	6502	EMCO	2210	300001015		
5	Anechoic chamber		MWB	87400/02	300000996		
6	System rack for EMI measurement solution	85900	HP I.V.	*	300000222		
7	Artificial Mains 9 kHz to 30 MHz, 4 x 25 Ampere	ESH3-Z5	R&S	828576/020	300001210	06.01.2010	06.01.2012
8	Relais Matrix	3488A	HP Meßtechnik	2719A15013	300001156		
9	Relais Matrix	PSU	R&S	890167/024	300001168		
10	Isolating Transformer	RT5A	Grundig	9242	300001263		
11	Three-Way Power Splitter, 50 Ohm	11850C	HP Meßtechnik		300000997		
12	Switch / Control Unit	3488A	HP	2605e08770	300001443		
13	Band Reject filter	WRCG1855/1910-1835/1925-40/8SS	Wainwright	7	300003350		
14	Band Reject filter	WRCG2400/2483-2375/2505-50/10SS	Wainwright	11	300003351		
15	TILE-Software Emission	Quantum Change, Modell TILE-ICS/FULL	EMCO	none	300003451		
16	Highpass Filter	WHKX2.9/18G-12SS	Wainwright	1	300003492		
17	Highpass Filter	WHK1.1/15G-10SS	Wainwright	3	300003255		
18	Highpass Filter	WHKX7.0/18G-8SS	Wainwright	18	300003789		
19	PSA Spectrum Analyzer 3 Hz - 26.5 GHz	E4440A	Agilent Vertr. Bad Hom	MY48250080	300003812	05.08.2008	05.08.2010
20	MXG Microwave Analog Signal Generator	N5183A	Agilent Vertr. Bad Hom	MY47420220	300003813	06.08.2008	06.08.2010
21	RF Filter Section 9kHz - 1GHz	N9039A	Agilent Vertr. Bad Hom	MY48260003	300003825	19.08.2008	19.08.2010
22	TRILOG Super Breitband Antenne	VULB9163	Schwarzbeck	371	300003854	17.12.2008	17.12.2010
23	DC Power Supply 0 – 32V	1108-32	Heiden	1802	300001383	13.05.2007	13.05.2010

24	Signal Analyzer 20Hz-26,5GHz- 150 to + 30 DBM	FSiQ26	R&S	835111/0004	300002678	06.01.2009	06.01.2011
25	Switch-Unit	3488A	HP Meßtechnik	2719A14505	300000368		
26	Netzgerät	6032A	HP Meßtechnik	2920A04466	300000580	06.01.2009	06.01.2011
27	EMI- Messempfänger	ESCI 1166.5950.03	R&S	100083	300003312	08.01.2010	08.01.2012
28	Amplifier	JS42-00502650-28- 5A	MITEQ	1084532	300003379		
29	Antennenmast	Model 2175	ETS- LINDGREN	64762	300003745		
30	Steuergerät	Model 2090	ETS- LINDGREN	64672	300003746		
31	Interface-Box für Drehtisch	Model 105637	ETS- LINDGREN	44583	300003747		
32	Breitbandantenne	VULB9163	Schwarzbeck	295	300003787	01.04.2010	01.04.2012
33	Spectrum- Analyzer	FSU26	R&S	200809	300003874	08.01.2010	08.01.2012

7 Photographs of the Test Set-up

Photo 1:

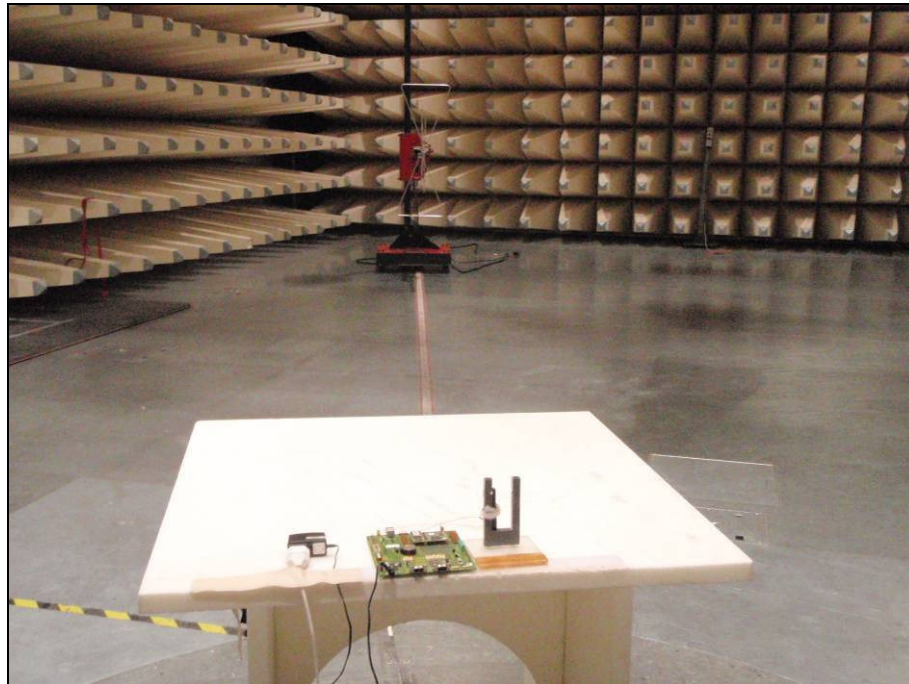

Photo 2:



8 Photographs of the EUT

Photo 3:

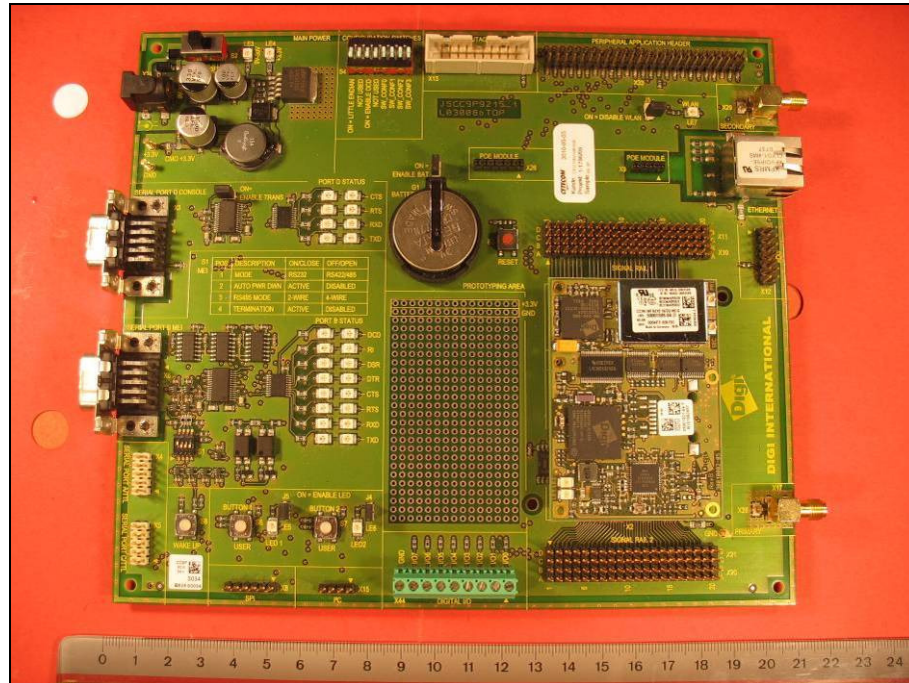

Photo 4:

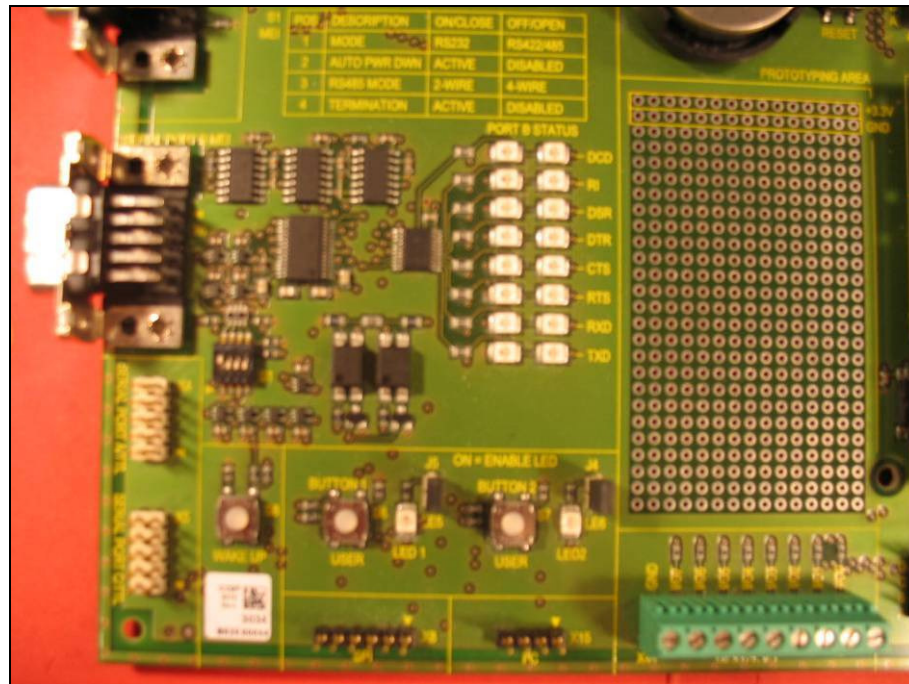

Photo 5:

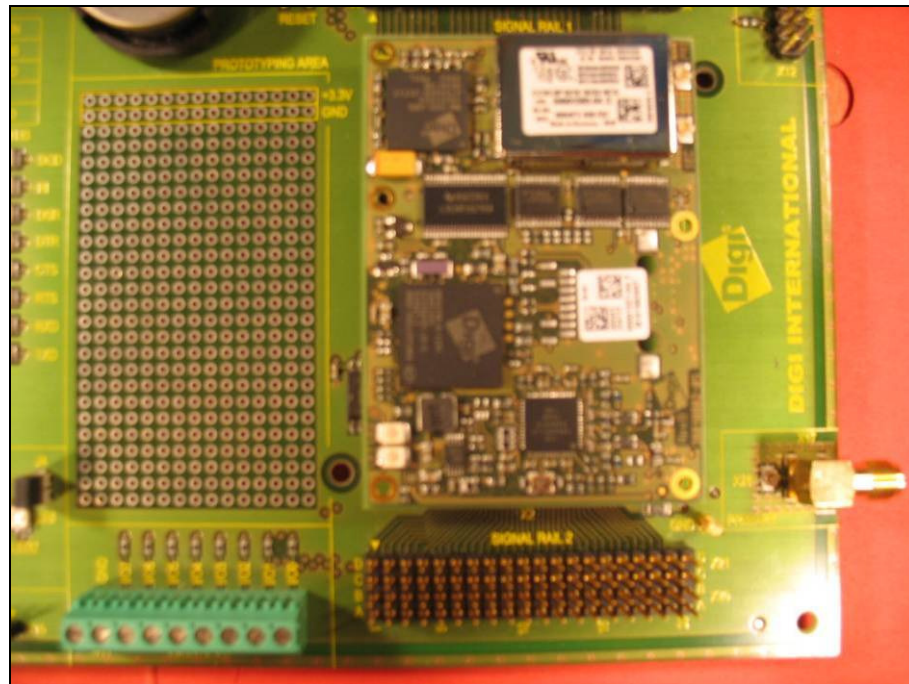

Photo 6:

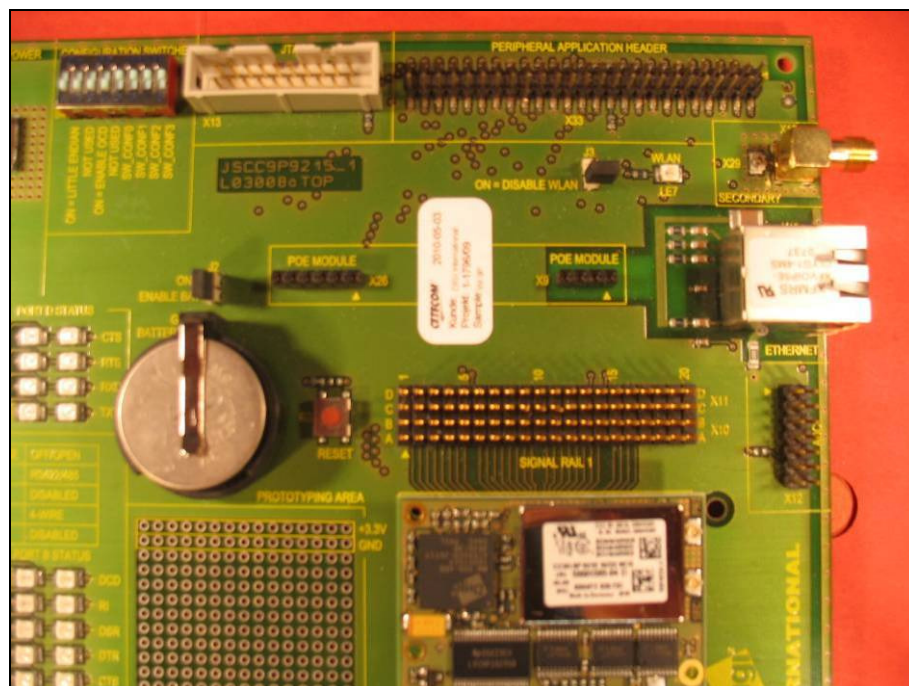

Photo 7:

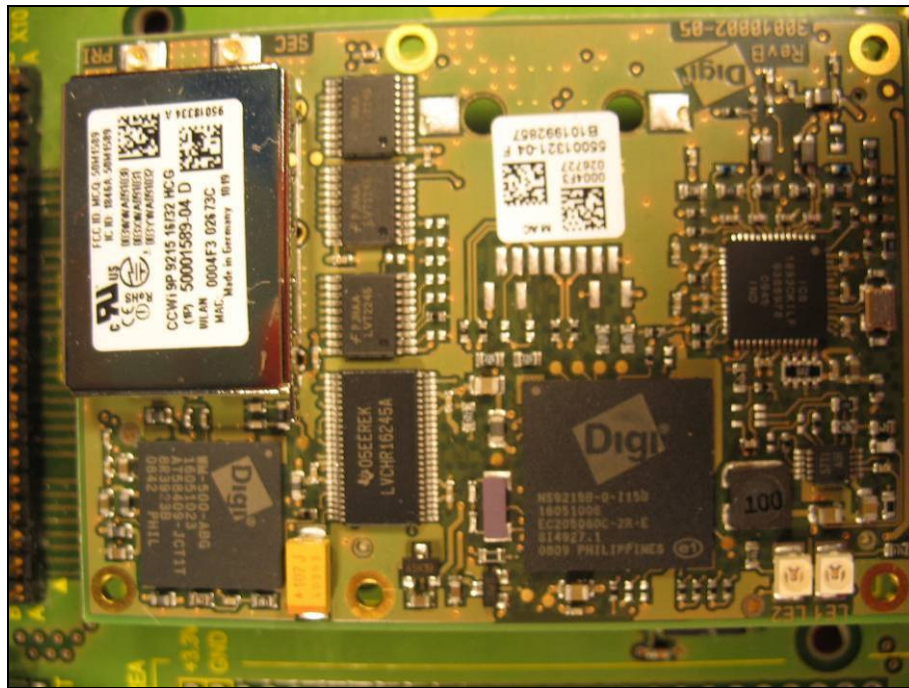

Photo 8:

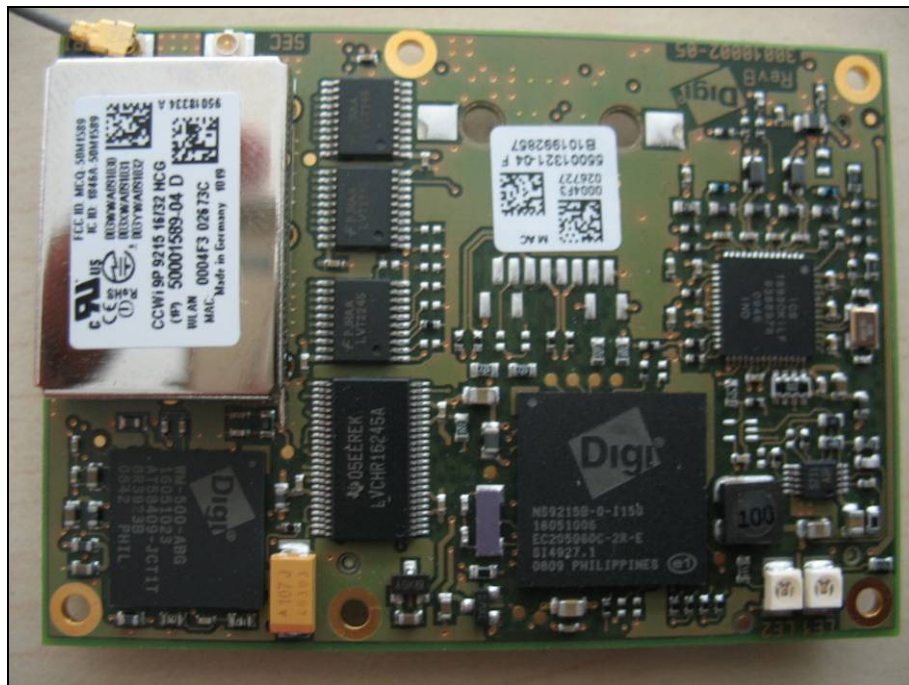

Photo 9:

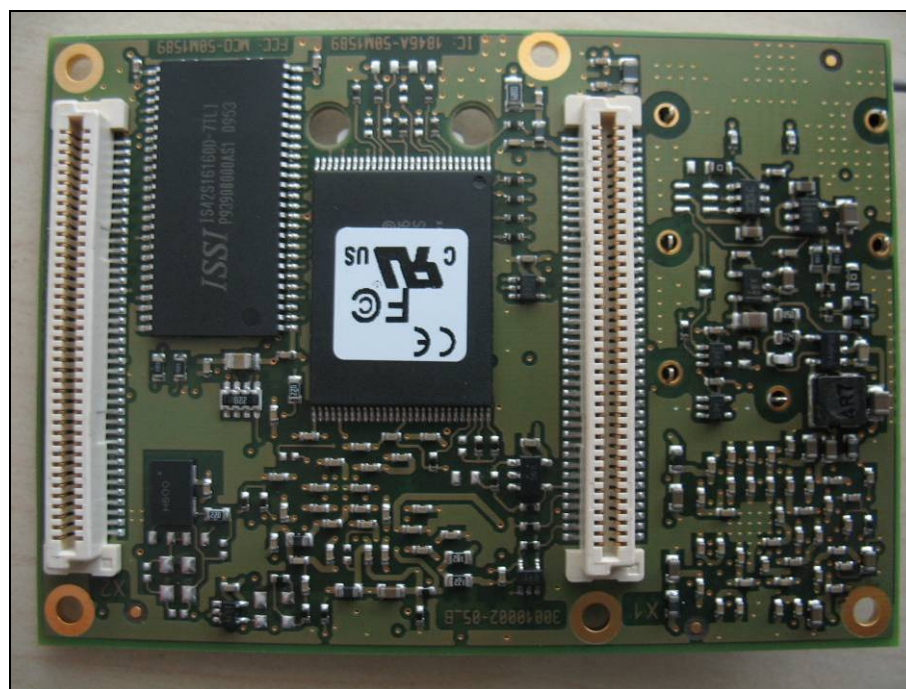

Photo 10:



Photo 11:



Photo 12:



Photo 13:

