



Neutron Engineering Inc.

FCC&IC Radio Test Report

FCC ID: MCLTTC509

IC: 2878D-TTC509

This report concerns (check one): Original Grant Class II Change

Issued Date : Nov. 05, 2013
Project No. : 1309C142
Equipment : Cisco TelePresence Touch 10
Model Name : TTC5-09
Applicant : Hon Hai Precision Ind. Co.,Ltd.
Address : 5F-1, 5, Hsin-An Road, Hsinchu
Science-Based Industrial Park,
Taiwan, R.O.C.

Tested by: Neutron Engineering Inc. EMC Laboratory
Date of Receipt: Oct. 18, 2013
Date of Test: Oct. 18, 2013 ~ Nov. 04, 2013

Neutron Engineering Inc.

No.3,Jinshagang 1st Road, ShiXia,
Dalang Town, Dong Guan, China.

TEL: 0769-8318-3000

FAX: 0769-8319-6000



Declaration

Neutron represents to the client that testing is done in accordance with standard procedures as applicable and that test instruments used has been calibrated with the standards traceable to National Measurement Laboratory (**NML**) of **CHINA**, or National Institute of Standards and Technology (**NIST**) of **U.S.A.**

Neutron's reports apply only to the specific samples tested under conditions. It is manufacture's responsibility to ensure that additional production units of this model are manufactured with the identical electrical and mechanical components. **Neutron** shall have no liability for any declarations, inferences or generalizations drawn by the client or others from **Neutron** issued reports.

Neutron's reports must not be used by the client to claim product endorsement by the authorities or any agency of the Government.

This report is the confidential property of the client. As a mutual protection to the clients, the public and **Neutron-self**, extracts from the test report shall not be reproduced except in full with **Neutron's** authorized written approval.

Neutron's laboratory quality assurance procedures are in compliance with the **ISO Guide 17025** requirements, and accredited by the conformity assessment authorities listed in this test report.

Limitation

For the use of the authority's logo is limited unless the Test Standard(s)/Scope(s)/Item(s) mentioned in this test report is (are) included in the conformity assessment authorities acceptance respective.



| Table of Contents | Page |
|--|-------------|
| 1 . CERTIFICATION | 6 |
| 2 . SUMMARY OF TEST RESULTS | 7 |
| 2.1 TEST FACILITY | 8 |
| 2.2 MEASUREMENT UNCERTAINTY | 8 |
| 3 . GENERAL INFORMATION | 9 |
| 3.1 GENERAL DESCRIPTION OF EUT | 9 |
| 3.2 DESCRIPTION OF TEST MODES | 11 |
| 3.3 TABLE OF PARAMETERS OF TEXT SOFTWARE SETTING | 11 |
| 3.4 BLOCK DIAGRAM SHOWING THE CONFIGURATION OF SYSTEM TESTED | 12 |
| 3.5 DESCRIPTION OF SUPPORT UNITS | 12 |
| 4 . EMC EMISSION TEST | 13 |
| 4.1 CONDUCTED EMISSION MEASUREMENT | 13 |
| 4.1.1 POWER LINE CONDUCTED EMISSION LIMITS | 13 |
| 4.1.2 MEASUREMENT INSTRUMENTS LIST AND SETTING | 13 |
| 4.1.3 TEST PROCEDURE | 14 |
| 4.1.4 DEVIATION FROM TEST STANDARD | 14 |
| 4.1.5 TEST SETUP | 14 |
| 4.1.6 EUT OPERATING CONDITIONS | 14 |
| 4.1.7 TEST RESULTS | 15 |
| 4.2 RADIATED EMISSION MEASUREMENT | 16 |
| 4.2.1 RADIATED EMISSION LIMITS | 16 |
| 4.2.2 MEASUREMENT INSTRUMENTS LIST AND SETTING | 17 |
| 4.2.3 TEST PROCEDURE | 17 |
| 4.2.4 DEVIATION FROM TEST STANDARD | 17 |
| 4.2.5 TEST SETUP | 18 |
| 4.2.6 EUT OPERATING CONDITIONS | 19 |
| 4.2.7 TEST RESULTS: 30MHZ - 1000MHZ | 20 |
| 4.2.8 TEST RESULTS (ABOVE 1000 MHZ) | 27 |
| 5 . NUMBER OF HOPPING CHANNEL | 51 |
| 5.1 APPLIED PROCEDURES | 51 |
| 5.1.1 MEASUREMENT INSTRUMENTS LIST AND SETTING | 51 |
| 5.1.2 TEST PROCEDURE | 51 |
| 5.1.3 DEVIATION FROM STANDARD | 51 |
| 5.1.4 TEST SETUP | 51 |
| 5.1.5 EUT OPERATION CONDITIONS | 51 |
| 5.1.6 TEST RESULTS | 52 |
| 6 . AVERAGE TIME OF OCCUPANCY | 54 |



| Table of Contents | Page |
|---|-----------|
| 6.1 APPLIED PROCEDURES / LIMIT | 54 |
| 6.1.1 MEASUREMENT INSTRUMENTS LIST | 54 |
| 6.1.2 TEST PROCEDURE | 54 |
| 6.1.3 DEVIATION FROM STANDARD | 54 |
| 6.1.4 TEST SETUP | 55 |
| 6.1.5 EUT OPERATION CONDITIONS | 55 |
| 6.1.6 TEST RESULTS | 56 |
| 7 . HOPPING CHANNEL SEPARATION MEASUREMENT | 68 |
| 7.1 APPLIED PROCEDURES / LIMIT | 68 |
| 7.1.1 MEASUREMENT INSTRUMENTS LIST AND SETTING | 68 |
| 7.1.2 TEST PROCEDURE | 68 |
| 7.1.3 DEVIATION FROM STANDARD | 68 |
| 7.1.4 TEST SETUP | 68 |
| 7.1.5 EUT OPERATION CONDITIONS | 68 |
| 7.1.6 TEST RESULTS | 69 |
| 8 . BANDWIDTH TEST | 73 |
| 8.1 APPLIED PROCEDURES | 73 |
| 8.1.1 MEASUREMENT INSTRUMENTS LIST AND SETTING | 73 |
| 8.1.2 TEST PROCEDURE | 73 |
| 8.1.3 DEVIATION FROM STANDARD | 73 |
| 8.1.4 TEST SETUP | 73 |
| 8.1.5 EUT OPERATION CONDITIONS | 73 |
| 8.1.6 TEST RESULTS | 74 |
| 9 . PEAKOUTPUT POWER TEST | 78 |
| 9.1 APPLIED PROCEDURES / LIMIT | 78 |
| 9.1.1 MEASUREMENT INSTRUMENTS LIST AND SETTING | 78 |
| 9.1.2 TEST PROCEDURE | 78 |
| 9.1.3 DEVIATION FROM STANDARD | 78 |
| 9.1.4 TEST SETUP | 78 |
| 9.1.5 EUT OPERATION CONDITIONS | 78 |
| 9.1.6 TEST RESULTS | 79 |
| 10 . ANTENNA CONDUCTED SPURIOUS EMISSION | 83 |
| 10.1 APPLIED PROCEDURES / LIMIT | 83 |
| 10.1.1 MEASUREMENT INSTRUMENTS LIST AND SETTING | 83 |
| 10.1.2 TEST PROCEDURE | 83 |
| 10.1.3 DEVIATION FROM STANDARD | 83 |
| 10.1.4 TEST SETUP | 84 |
| 10.1.5 EUT OPERATION CONDITIONS | 84 |
| 10.1.6 TEST RESULTS | 85 |
| 11 . EUT TEST PHOTO | 97 |



REPORT ISSUED HISTORY

| Issued No. | Description | Issued Date |
|---------------------|-----------------|---------------|
| NEI-FICP-1-1309C142 | Original Issue. | Nov. 05, 2013 |



1. CERTIFICATION

Equipment : Cisco TelePresence Touch 10
Brand Name : Cisco
Model Name : TTC5-09
Applicant : Hon Hai Precision Ind. Co.,Ltd.
Manufacturer : Cisco Systems, Inc.
Address : 170 West Tasman Drive San Jose, CA95134-1706 USA
Factory : 1) HONG FU JIN PRECISION INDUSTRY (SHEN ZHEN) CO LTD
2) Foxconn Assembly LLC
Address : 1) Bldg. D10,F21, No. 2, 2ND DONGHUAN ROAD, 10TH YOUSONG INDUSTRIAL DISTRICT, LONGHUA TOWN,BAOAN, SHENZHEN, GUANGDONG, CHINA, Postal code: 518109
2) 11177 Compaq Center Drive West,Houston,Texas 77070,USA
Date of Test : Oct. 18, 2013 ~ Nov. 04, 2013
Test Item : ENGINEERING SAMPLE
Standard(s) : FCC Part15, Subpart C(15.247) / ANSI C63.4 : 2009 / FCC Public Notice DA 00-705, March 30, 2000. Canada RSS-210:2010 RSS-GEN Issue 3, Dec 2010

The above equipment has been tested and found compliance with the requirement of the relative standards by Neutron Engineering Inc. EMC Laboratory.
This test report consists of 98 pages in total.
The test data, data evaluation, and equipment configuration contained in our test report (Ref No. NEI-FICP-1-1309C142) were obtained utilizing the test procedures, test instruments, test sites that has been accredited by the Authority of TAF according to the ISO-17025 quality assessment standard and technical standard(s).

Testing Engineer : David Mao
(David Mao)

Technical Manager : Leo Hung
(Leo Hung)

Authorized Signatory : Steven Lu
(Steven Lu)



2. SUMMARY OF TEST RESULTS

Test procedures according to the technical standard(s):

| Applied Standard(s): 47 CFR Part 15, Subpart C; Canada RSS-210:2010; RSS-GEN Issue 3, Dec 2010 | | | | |
|---|--|-------------------------------------|----------|----------|
| Standard(s) Section | | Test Item | Judgment | Remark |
| 47 CFR Part 15 | RSS-210/RSS-GEN | | | |
| 15.207 | RSS-GEN Issue 3, Dec 2010 7.2.4 | Conducted Emission | N/A | Note (1) |
| 15.247(d) | RSS-210, Issue 8, Annex 8, A8.5 | Antenna conducted Spurious Emission | PASS | |
| 15.247 (a)(1) | RSS-210, Issue 8, Annex 8, A8.1(b) | Hopping Channel Separation | PASS | |
| 15.247 (b)(1) | RSS-210, Issue 8, Annex 8, A8.1(b) | Peak Output Power | PASS | |
| 15.247(d) 15.209 | RSS-210, Issue 8, Annex 8, Section 8.5 | Radiated Spurious Emission | PASS | |
| 15.247 (a)(1)(iii) | RSS-210, Issue 8, Annex 8, A8.1(d) | Number of Hopping Frequency | PASS | |
| 15.247 (a)(1)(iii) | RSS-210, Issue 8, Annex 8, A8.1(d) | Dwell Time | PASS | |
| 15.205 | RSS-GEN Issue 3, Dec 2010 7.2.2 | Restricted Bands | PASS | |
| 15.203 | - | Antenna Requirement | PASS | |

Note:

- (1) "N/A" denotes test is not applicable in this test report
- (2) According to FCC Public Notice DA 00-705, March 30, 2000.



2.1 TEST FACILITY

The test facilities used to collect the test data in this report is **DG-CB03** at the location of No.3,Jinshagang 1st Road, Shixia, Dalang Town, Dong Guan, China.523792

Neutron's test firm number for FCC: 319330

Neutron's test firm number for IC: 4428B-1

2.2 MEASUREMENT UNCERTAINTY

Where relevant, the following measurement uncertainty levels have been estimated for tests performed on the EUT as specified in CISPR 16-4-2:

The reported uncertainty of measurement $y \pm U$, where expanded uncertainty **U** is based on a standard uncertainty multiplied by a coverage factor of **k=2**, providing a level of confidence of approximately **95 %**.

A. Conducted Measurement :

| Test Site | Method | Measurement Frequency Range | U , (dB) | Note |
|-----------|--------|-----------------------------|----------|------|
| DG-C02 | CISPR | 150 KHz ~ 30MHz | 1.94 | |

B. Radiated Measurement :

| Test Site | Method | Measurement Frequency Range | Ant. H / V | U , (dB) | Note |
|-----------|--------|-----------------------------|------------|----------|------|
| DG-CB03 | CISPR | 9KHz~30MHz | V | 3.79 | |
| | | 9KHz~30MHz | H | 3.57 | |
| | | 30MHz ~ 200MHz | V | 3.82 | |
| | | 30MHz ~ 200MHz | H | 3.60 | |
| | | 200MHz ~ 1,000MHz | V | 3.86 | |
| | | 200MHz ~ 1,000MHz | H | 3.94 | |
| | | 1GHz~18GHz | V | 3.12 | |
| | | 1GHz~18GHz | H | 3.68 | |
| | | 18GHz~40GHz | V | 4.15 | |
| | | 18GHz~40GHz | H | 4.14 | |



3. GENERAL INFORMATION

3.1 GENERAL DESCRIPTION OF EUT

| | | |
|---|--|------------------------------------|
| Equipment | Cisco TelePresence Touch 10 | |
| Brand Name | Cisco | |
| Model Name | TTC5-09 | |
| Model Difference | N/A | |
| Product Description | Operation Frequency | 2402~2480 MHz |
| | Modulation Technology | GFSK(1Mbps) |
| | Bit Rate of Transmitter | π /4-DQPSK(2Mbps) |
| | | 8-DPSK(3Mbps) |
| | Number of Channel | 79 CH, Please see note 2.(Page 10) |
| | Antenna Designation | Please see note 3.(Page 10) |
| | Antenna Gain(Peak) | |
| | Output Power (Max.) | 5.13 dBm (1Mbps) |
| 6.73 dBm (3Mbps) | | |
| More details of EUT technical specification, please refer to the User's Manual. | | |
| Power Source | Supplied from PoE. | |
| Power Rating | DC 48Vdc / 0.25A | |
| Connecting I/O Port(s) | USB port*2 Audio out port Ethernet port Mini USB port*2 Bluetooth NFC | |

Note:

1. For a more detailed features description, please refer to the manufacturer's specifications or the User's Manual.



2.

| Channel List | | | | | |
|--------------|-----------------|---------|-----------------|---------|-----------------|
| Channel | Frequency (MHz) | Channel | Frequency (MHz) | Channel | Frequency (MHz) |
| 00 | 2402 | 27 | 2429 | 54 | 2456 |
| 01 | 2403 | 28 | 2430 | 55 | 2457 |
| 02 | 2404 | 29 | 2431 | 56 | 2458 |
| 03 | 2405 | 30 | 2432 | 57 | 2459 |
| 04 | 2406 | 31 | 2433 | 58 | 2460 |
| 05 | 2407 | 32 | 2434 | 59 | 2461 |
| 06 | 2408 | 33 | 2435 | 60 | 2462 |
| 07 | 2409 | 34 | 2436 | 61 | 2463 |
| 08 | 2410 | 35 | 2437 | 62 | 2464 |
| 09 | 2411 | 36 | 2438 | 63 | 2465 |
| 10 | 2412 | 37 | 2439 | 64 | 2466 |
| 11 | 2413 | 38 | 2440 | 65 | 2467 |
| 12 | 2414 | 39 | 2441 | 66 | 2468 |
| 13 | 2415 | 40 | 2442 | 67 | 2469 |
| 14 | 2416 | 41 | 2443 | 68 | 2470 |
| 15 | 2417 | 42 | 2444 | 69 | 2471 |
| 16 | 2418 | 43 | 2445 | 70 | 2472 |
| 17 | 2419 | 44 | 2446 | 71 | 2473 |
| 18 | 2420 | 45 | 2447 | 72 | 2474 |
| 19 | 2421 | 46 | 2448 | 73 | 2475 |
| 20 | 2422 | 47 | 2449 | 74 | 2476 |
| 21 | 2423 | 48 | 2450 | 75 | 2477 |
| 22 | 2424 | 49 | 2451 | 76 | 2478 |
| 23 | 2425 | 50 | 2452 | 77 | 2479 |
| 24 | 2426 | 51 | 2453 | 78 | 2480 |
| 25 | 2427 | 52 | 2454 | | |
| 26 | 2428 | 53 | 2455 | | |

3 Table for Filed Antenna

| Ant. | Brand | Model Name | Antenna Type | Connector | Gain (dBi) |
|------|-------|----------------|--------------|-----------|------------|
| 1 | INPAQ | WA-P-LA-03-086 | PCB | N/A | 4 |



3.2 DESCRIPTION OF TEST MODES

To investigate the maximum EMI emission characteristics generated from EUT, the test system was pre-scanning tested based on the consideration of following EUT operation mode or test configuration mode which possibly have effect on EMI emission level. Each of these EUT operation mode(s) or test configuration mode(s) mentioned above was evaluated respectively.

| Pretest Mode | Description |
|--------------|-------------------------|
| Mode 1 | TX Mode Note (1) |

The EUT system operated these modes were found to be the worst case during the pre-scanning test as following:

| For Conducted Emission | |
|------------------------|---|
| Final Test Mode | Description |
| N/A | " N/A" denotes test is not applicable in this test report |

| For Radiated Emission | |
|-----------------------|-------------------------|
| Final Test Mode | Description |
| Mode 1 | TX Mode Note (1) |

For radiated below 1G test, the 1Mbps mode is found to be the worst case and recorded.

Note:

- (1) The measurements are performed at the high, middle, low available channels.
- (2) The measurements for Hopping Channel Separation, Bandwidth and Peak Output Power were tested during 1Mbps, 2Mbps and 3Mbps, the worst case are 1Mbps and 3Mbps, only worst case was documented.
- (3) The EUT was pre-tested on positioned of each 3 axis. The worst case was found positioned on X-plane. Therefore only the test data of this X-plane was used for radiated emission measurement test.

3.3 TABLE OF PARAMETERS OF TEST SOFTWARE SETTING

During testing, channel & power controlling software provided by the customer was used to control the operating channel as well as the output power level. The RF output power selection is for the setting of RF output power expected by the customer and is going to be fixed on the firmware of the final end product power parameters of FHSS

| Test software version | DOS | | |
|-----------------------|----------|----------|----------|
| Frequency | 2402 MHz | 2441 MHz | 2480 MHz |
| Parameters-1Mbps | 8 | 8 | 8 |
| Parameters-3Mbps | 4 | 4 | 4 |



3.4 BLOCK DIAGRAM SHOWING THE CONFIGURATION OF SYSTEM TESTED

Radiated TX Mode:

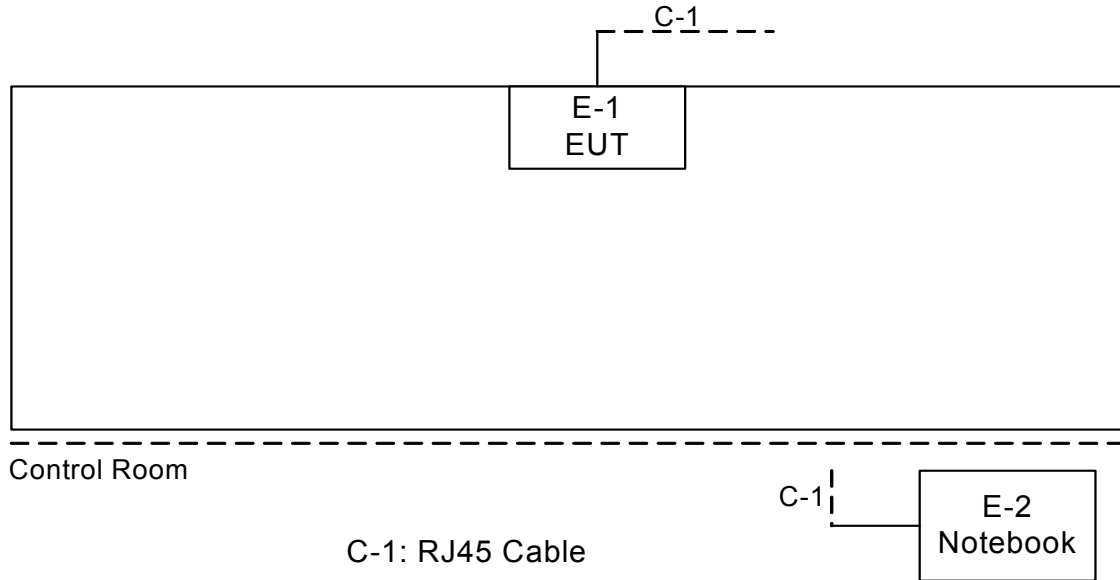

| Item | Shielded Type | Ferrite Core | Length | Note |
|------|---------------|--------------|--------|--------------------------------|
| C-1 | NO | NO | 10m | Between the EUT and a Notebook |

Note:

- (1) For detachable type I/O cable should be specified the length in m in 『Length』 column.

3.5 DESCRIPTION OF SUPPORT UNITS

The EUT has been tested as an independent unit together with other necessary accessories or support units. The following support units or accessories were used to form a representative test configuration during the tests.

| Item | Equipment | Mfr/Brand | Model/Type No. | FCC ID/IC | Series No. | Note |
|------|-----------------------------|-----------|----------------|--------------------------|---------------|------|
| E-1 | Cisco TelePresence Touch 10 | Cisco | TTC5-09 | MCLTTC509 / 2878D-TTC509 | N/A | EUT |
| E-2 | Notebook | Dell | INSPIRON 1420 | DOC | JX193A01SD C2 | |



4. EMC EMISSION TEST

4.1 CONDUCTED EMISSION MEASUREMENT

4.1.1 POWER LINE CONDUCTED EMISSION LIMITS (Frequency Range 150KHz-30MHz)

| Frequency (MHz) | Class A (dBuV) | | Class B (dBuV) | | Standard |
|-----------------|----------------|---------|----------------|-----------|----------|
| | Quasi-peak | Average | Quasi-peak | Average | |
| 0.15 -0.5 | 79.00 | 66.00 | 66 - 56 * | 56 - 46 * | CISPR |
| 0.50 -5.0 | 73.00 | 60.00 | 56.00 | 46.00 | CISPR |
| 5.0 -30.0 | 73.00 | 60.00 | 60.00 | 50.00 | CISPR |
| | | | | | |
| 0.15 -0.5 | 79.00 | 66.00 | 66 - 56 * | 56 - 46 * | FCC |
| 0.50 -5.0 | 73.00 | 60.00 | 56.00 | 46.00 | FCC |
| 5.0 -30.0 | 73.00 | 60.00 | 60.00 | 50.00 | FCC |

Note:

- (1) The tighter limit applies at the band edges.
- (2) The limit of " * " marked band means the limitation decreases linearly with the logarithm of the frequency in the range.

4.1.2 MEASUREMENT INSTRUMENTS LIST AND SETTING

| Item | Kind of Equipment | Manufacturer | Type No. | Serial No. | Calibrated until |
|------|-------------------|--------------|----------|------------|------------------|
| 1 | LISN | EMCO | 3816/2 | 00052765 | Apr. 25, 2014 |
| 2 | LISN | R&S | ENV216 | 100087 | Nov.16, 2013 |
| 3 | Test Cable | N/A | C_17 | N/A | Mar.15, 2014 |
| 4 | EMI TEST RECEIVER | R&S | ESCS30 | 826547/022 | Apr. 25, 2014 |
| 5 | 50Ω Terminator | SHX | TF2-3G-A | 08122902 | Apr. 25, 2014 |

Remark: "N/A" denotes no model name, serial no. or calibration specified.

All calibration period of equipment list is one year.

The test was performed in DG-C02.

The following table is the setting of the receiver

| Receiver Parameters | Setting |
|---------------------|----------|
| Attenuation | 10 dB |
| Start Frequency | 0.15 MHz |
| Stop Frequency | 30 MHz |
| IF Bandwidth | 9 KHz |

4.1.3 TEST PROCEDURE

- The EUT was placed 0.8 meters from the horizontal ground plane with EUT being connected to the power mains through a line impedance stabilization network (LISN). All other support equipments powered from additional LISN(s). The LISN provide 50 Ohm/ 50uH of coupling impedance for the measuring instrument.
- Interconnecting cables that hang closer than 40 cm to the ground plane shall be folded back and forth in the center forming a bundle 30 to 40 cm long.
- I/O cables that are not connected to a peripheral shall be bundled in the center. The end of the cable may be terminated, if required, using the correct terminating impedance. The overall length shall not exceed 1 m.
- LISN at least 80 cm from nearest part of EUT chassis.
- For the actual test configuration, please refer to the related Item –EUT Test Photos.

4.1.4 DEVIATION FROM TEST STANDARD

No deviation

4.1.5 TEST SETUP

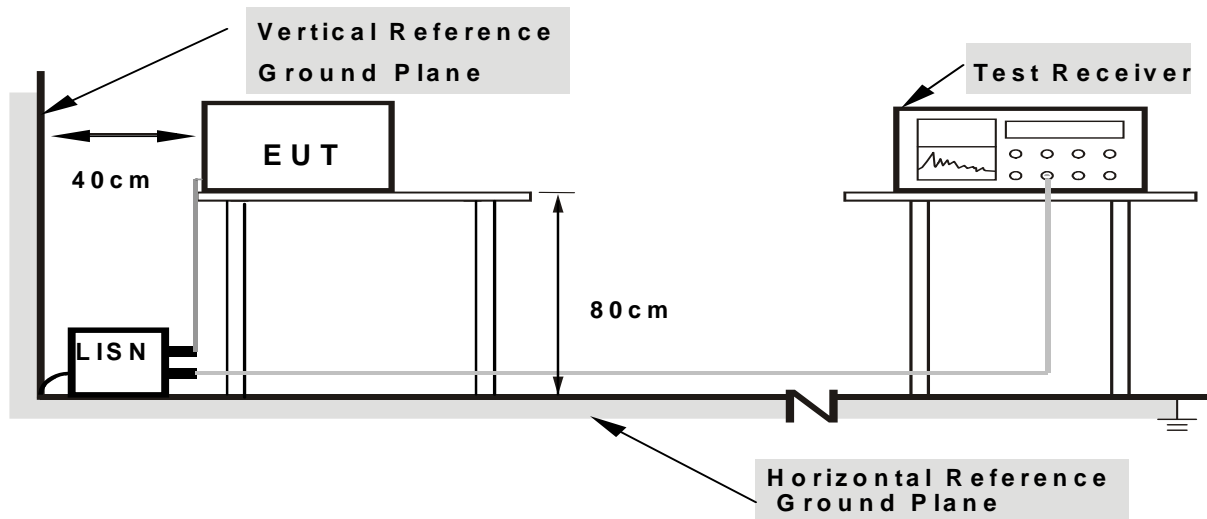

Note: 1. Support units were connected to second LISN.

2. Both of LISNs (AMN) are 80 cm from EUT and at least 80 cm from other units and other metal planes

4.1.6 EUT OPERATING CONDITIONS

The EUT was configured for testing in a typical fashion (as a customer would normally use it). The EUT has been programmed to continuously transmit during test. This operating condition was tested and used to collect the included data.

The EUT was programmed to be in continuously transmitting/receiving data or hopping on mode.



4.1.7 TEST RESULTS

| | | | |
|--------------|-----------------------------|--------------------|---------|
| EUT: | Cisco TelePresence Touch 10 | Model Name : | TTC5-09 |
| Temperature: | - | Relative Humidity: | - |
| Test Power: | - | Phase: | - |
| Test Mode: | N/A | | |

Remark:

- (1) All readings are QP Mode value unless otherwise stated AVG in column of 'Note'. If the QP Mode Measured value compliance with the QP Limits and lower than AVG Limits, the EUT shall be deemed to meet both QP & AVG Limits and then only QP Mode was measured, but AVG Mode didn't perform in this case, a "*" marked in AVG Mode column of Interference Voltage Measured.
- (2) Measuring frequency range from 150KHz to 30MHz.
- (3) " N/A" denotes test is not applicable in this test report



4.2 RADIATED EMISSION MEASUREMENT

4.2.1 RADIATED EMISSION LIMITS (Frequency Range 9KHz -1000MHz)

20dB in any 100 KHz bandwidth outside the operating frequency band. In case the emission fall within the restricted band specified on 15.205(a), then the 15.209(a) limit in the table below has to be followed.

| Frequency (MHz) | Field Strength (microvolts/meter) | Measurement Distance (meters) |
|-----------------|-----------------------------------|-------------------------------|
| 0.009~0.490 | 2400/F(KHz) | 300 |
| 0.490~1.705 | 24000/F(KHz) | 30 |
| 1.705~30.0 | 30 | 30 |
| 30~88 | 100 | 3 |
| 88~216 | 150 | 3 |
| 216~960 | 200 | 3 |
| 960~1000 | 500 | 3 |

LIMITS OF RADIATED EMISSION MEASUREMENT (Above 1000MHz)

| Frequency (MHz) | (dBuV/m) (at 3 meters) | |
|-----------------|------------------------|---------|
| | Peak | Average |
| Above 1000 | 74 | 54 |

Notes:

- (1) The limit for radiated test was performed according to FCC PART 15C.
- (2) The tighter limit applies at the band edges.
- (3) Emission level (dBuV/m) =20log Emission level (uV/m).

| Spectrum Parameter | Setting |
|--|--|
| Attenuation | Auto |
| Start Frequency | 1000 MHz |
| Stop Frequency | 10th carrier harmonic |
| RBW / VBW (emission in restricted band) | 1 MHz / 1 MHz for Peak, 1 MHz / 10Hz for Average |

| Receiver Parameter | Setting |
|------------------------|------------------------------------|
| Attenuation | Auto |
| Start ~ Stop Frequency | 9KHz ~90KHz for PK/AVG detector |
| Start ~ Stop Frequency | 90KHz ~110KHz for QP detector |
| Start ~ Stop Frequency | 110KHz ~490KHz for PK/AVG detector |
| Start ~ Stop Frequency | 490KHz ~30MHz for QP detector |
| Start ~ Stop Frequency | 30MHz~1000MHz for QP detector |



4.2.2 MEASUREMENT INSTRUMENTS LIST AND SETTING

| Item | Kind of Equipment | Manufacturer | Type No. | Serial No. | Calibrated until |
|------|-------------------------|--------------|-----------|------------|------------------|
| 1 | Antenna | Schwarbeck | VULB9160 | 9160-3232 | Apr. 25, 2014 |
| 2 | Amplifier | HP | 8447D | 2944A09673 | Apr. 25, 2014 |
| 3 | Test Receiver | R&S | ESCI | 100382 | Apr. 25, 2014 |
| 4 | Test Cable | N/A | C-01_CB03 | N/A | Jul. 02, 2014 |
| 5 | Antenna | ETS | 3115 | 00075789 | Apr. 25, 2014 |
| 6 | Amplifier | Agilent | 8449B | 3008A02274 | Apr. 25, 2014 |
| 7 | Spectrum | Agilent | E4408B | US39240143 | Nov. 16, 2013 |
| 8 | Test Cable | HUBER+SUHNER | C-45 | N/A | Apr. 30, 2014 |
| 9 | Controller | CT | SC100 | N/A | N/A |
| 10 | Horn Antenna | EMCO | 3115 | 9605-4803 | Apr. 25, 2014 |
| 11 | Active Loop Antenna | R&S | HFH2-Z2 | 830749/020 | Apr. 25, 2014 |
| 12 | Broad-Band Horn Antenna | Schwarzbeck | BBHA 9170 | 9170319 | Oct. 22, 2014 |

Remark: "N/A" denotes no model name, serial no. or calibration specified.

All calibration period of equipment list is one year.

The test was performed in DG-CB03.

4.2.3 TEST PROCEDURE

- a. The EUT was placed on the top of a rotating table 0.8 meters above the ground at a 3 meter semi-anechoic chamber. The table was rotated 360 degrees to determine the position of the highest radiation.(below 1GHz)
- b. The EUT was placed on the top of a rotating table 0.8 meters above the ground at a 3 meter semi-anechoic chamber. The table was rotated 360 degrees to determine the position of the highest radiation.(above 1GHz)
- c. The height of the equipment or of the substitution antenna shall be 0.8 m; the height of the test antenna shall vary between 1 m to 4 m. Both horizontal and vertical polarizations of the antenna are set to make the measurement.
- d. The initial step in collecting conducted emission data is a spectrum analyzer peak detector mode pre-scanning the measurement frequency range. Significant peaks are then marked and then Quasi Peak detector mode re-measured.
- e. If the Peak Mode measured value compliance with and lower than Quasi Peak Mode Limit, the EUT shall be deemed to meet QP Limits and then no additional QP Mode measurement performed.
- f. For the actual test configuration, please refer to the related Item –EUT Test Photos.

4.2.4 DEVIATION FROM TEST STANDARD

No deviation

4.2.5 TEST SETUP

(A) Radiated Emission Test Set-Up Frequency Below 1 GHz

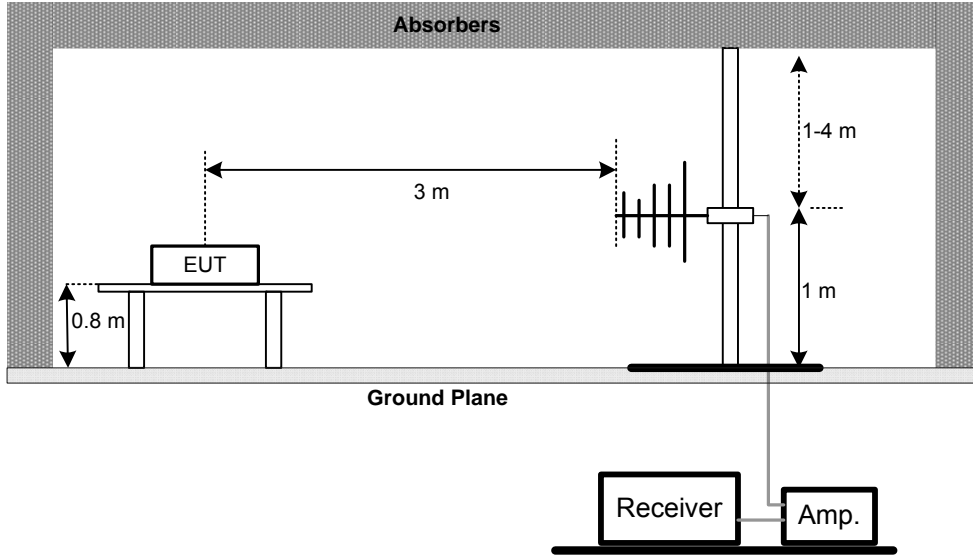

(B) Radiated Emission Test Set-Up Frequency Above 1 GHz

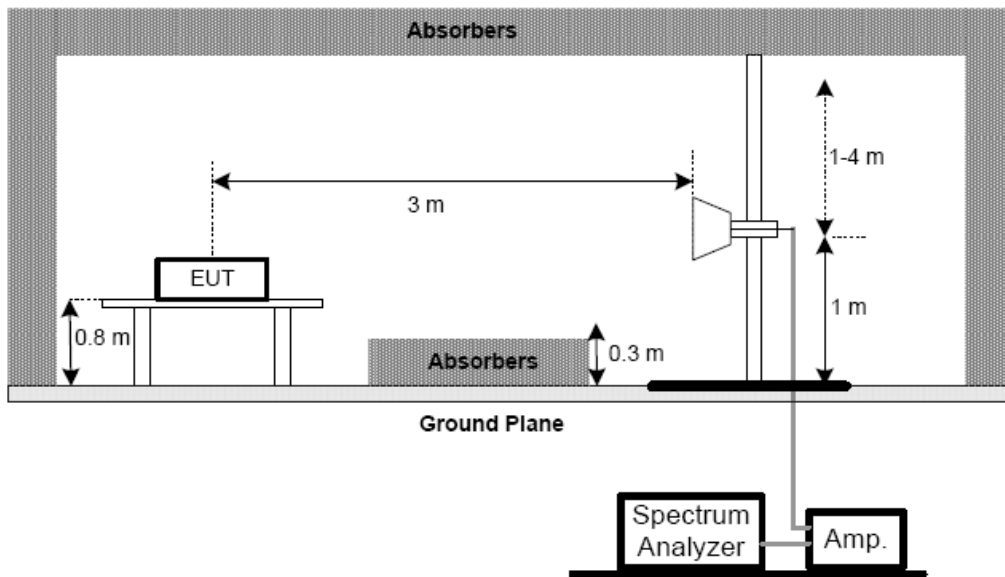

(C) For radiated emissions below 30MHz

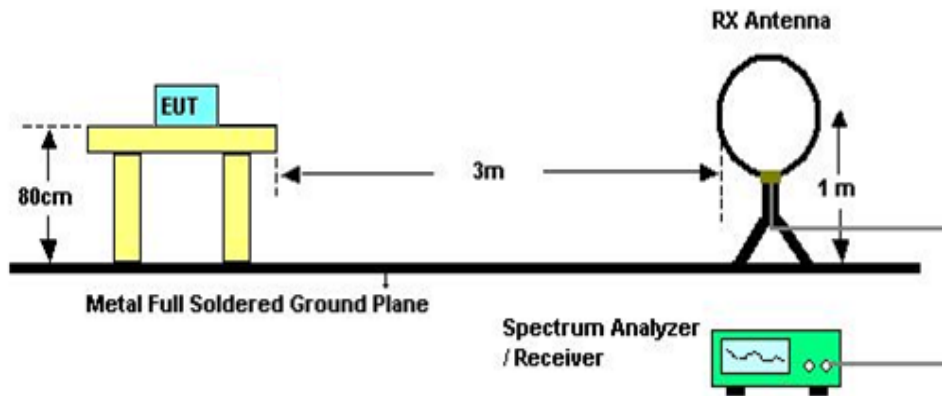

4.2.6 EUT OPERATING CONDITIONS

The EUT tested system was configured as the statements of 4.1.6 Unless otherwise a special operating condition is specified in the follows during the testing.



4.2.7 TEST RESULTS: 30MHZ - 1000MHZ

Remark:

- (1) Reading in which marked as QP or Peak means measurements by using are Quasi-Peak Mode or Peak Mode with Detector BW=120KHz ; SPA setting in RBW=120KHz, VBW =120KHz, Swp. Time = 0.3 sec./MHz.
- (2) All readings are Peak unless otherwise stated QP in column of 『Note』 . Peak denotes that the Peak reading compliance with the QP Limits and then QP Mode measurement didn't perform.
- (3) Measuring frequency range from 30MHz to 1000MHz.
- (4) If the peak scan value lower limit more than 20dB, then this signal data does not show in table.



| | | | |
|--------------|-----------------------------|--------------------|----------|
| EUT: | Cisco TelePresence Touch 10 | Model Name: | TTC5-09 |
| Temperature: | 28 °C | Relative Humidity: | 56 % |
| Test Power: | DC 48V | Polarization: | Vertical |
| Test Mode: | TX 2402MHz -CH00 -1Mbps | | |

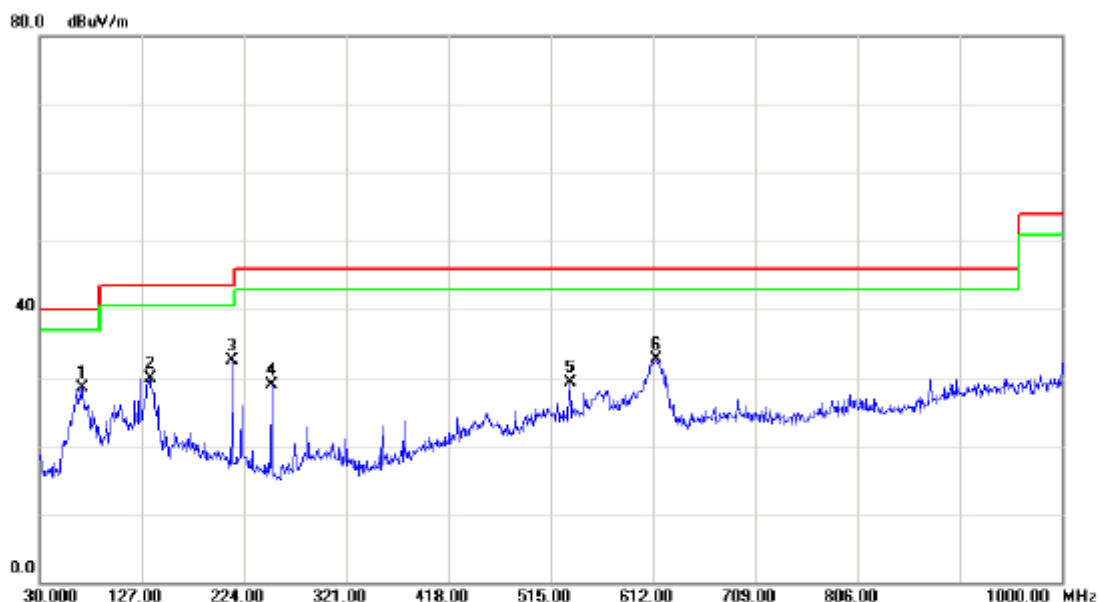

| No. | Mk. | Freq. MHz | Reading Level dBuV | Correct Factor dB | Measure- ment dBuV/m | Limit dBuV/m | Over dB | Detector | Comment |
|-----|-----|--------------|--------------------------|-------------------------|----------------------------|-----------------|------------|----------|---------|
| 1 | | 70.7400 | 44.80 | -16.37 | 28.43 | 40.00 | -11.57 | peak | |
| 2 | | 134.7600 | 43.53 | -13.55 | 29.98 | 43.50 | -13.52 | peak | |
| 3 | * | 213.3300 | 47.75 | -15.17 | 32.58 | 43.50 | -10.92 | peak | |
| 4 | | 250.1900 | 43.83 | -14.97 | 28.86 | 46.00 | -17.14 | peak | |
| 5 | | 533.4300 | 37.91 | -8.55 | 29.36 | 46.00 | -16.64 | peak | |
| 6 | | 614.9100 | 39.96 | -7.34 | 32.62 | 46.00 | -13.38 | peak | |



| | | | |
|--------------|-----------------------------|--------------------|------------|
| EUT: | Cisco TelePresence Touch 10 | Model Name: | TTC5-09 |
| Temperature: | 28 °C | Relative Humidity: | 56 % |
| Test Power: | DC 48V | Polarization: | Horizontal |
| Test Mode: | TX 2402MHz -CH00 -1Mbps | | |

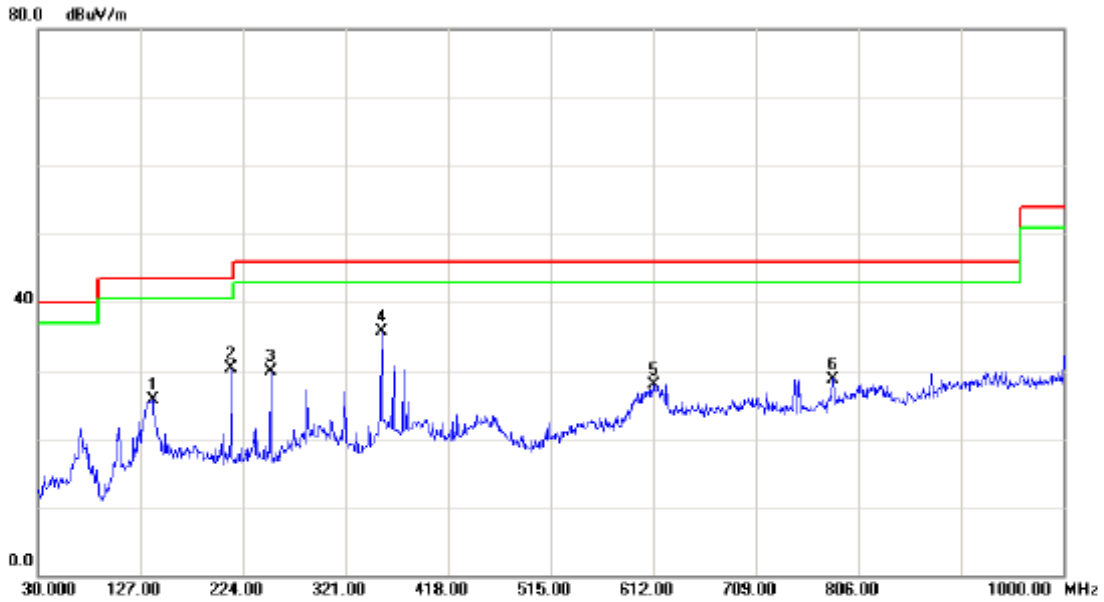

| No. Mk. | Freq. MHz | Reading Level dBuV | Correct Factor dB | Measurement dBuV/m | Limit dBuV/m | Over dB | Detector | Comment |
|---------|-----------|--------------------|-------------------|--------------------|--------------|---------|----------|---------|
| 1 | 138.6400 | 39.49 | -13.72 | 25.77 | 43.50 | -17.73 | peak | |
| 2 | 213.3300 | 45.38 | -15.17 | 30.21 | 43.50 | -13.29 | peak | |
| 3 | 250.1900 | 44.81 | -14.97 | 29.84 | 46.00 | -16.16 | peak | |
| 4 * | 354.9500 | 46.94 | -11.30 | 35.64 | 46.00 | -10.36 | peak | |
| 5 | 612.0000 | 35.46 | -7.49 | 27.97 | 46.00 | -18.03 | peak | |
| 6 | 781.7500 | 32.57 | -3.77 | 28.80 | 46.00 | -17.20 | peak | |



| | | | |
|--------------|-----------------------------|--------------------|----------|
| EUT: | Cisco TelePresence Touch 10 | Model Name: | TTC5-09 |
| Temperature: | 28 °C | Relative Humidity: | 56 % |
| Test Power: | DC 48V | Polarization: | Vertical |
| Test Mode: | TX 2441MHz -CH39 -1Mbps | | |

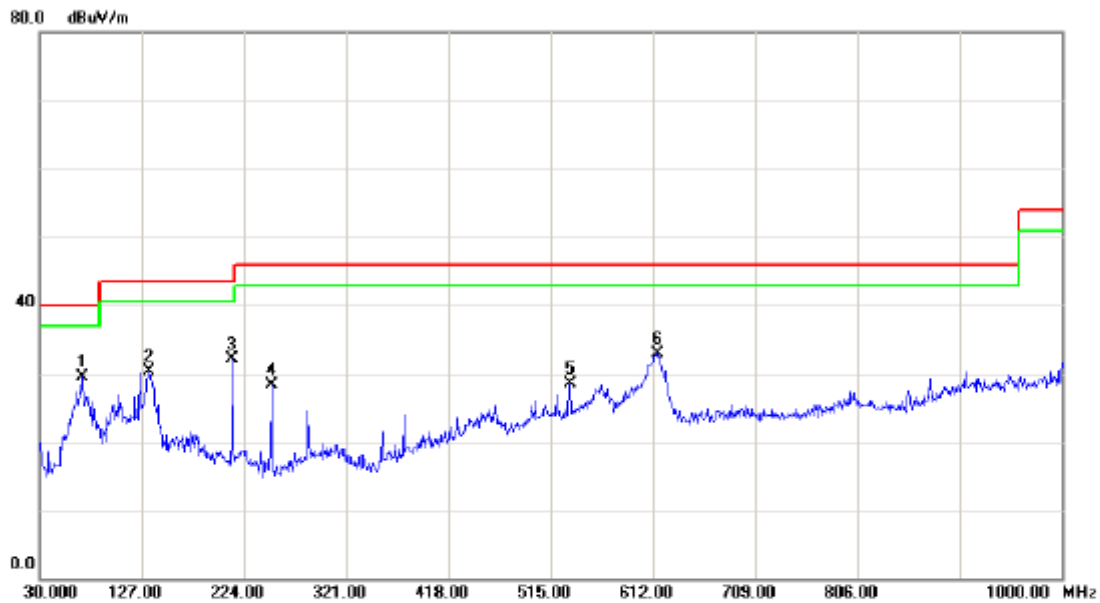

| No. | Mk. | Freq. MHz | Reading Level dBuV | Correct Factor dB | Measure- ment dBuV/m | Limit dBuV/m | Over dB | Detector | Comment |
|-----|-----|--------------|--------------------------|-------------------------|----------------------------|-----------------|------------|----------|---------|
| 1 | * | 70.7400 | 45.81 | -16.37 | 29.44 | 40.00 | -10.56 | peak | |
| 2 | | 133.7900 | 43.83 | -13.50 | 30.33 | 43.50 | -13.17 | peak | |
| 3 | | 213.3300 | 47.31 | -15.17 | 32.14 | 43.50 | -11.36 | peak | |
| 4 | | 250.1900 | 43.23 | -14.97 | 28.26 | 46.00 | -17.74 | peak | |
| 5 | | 533.4300 | 37.09 | -8.55 | 28.54 | 46.00 | -17.46 | peak | |
| 6 | | 615.8800 | 40.22 | -7.30 | 32.92 | 46.00 | -13.08 | peak | |



| | | | |
|--------------|-----------------------------|--------------------|------------|
| EUT: | Cisco TelePresence Touch 10 | Model Name: | TTC5-09 |
| Temperature: | 28 °C | Relative Humidity: | 56 % |
| Test Power: | DC 48V | Polarization: | Horizontal |
| Test Mode: | TX 2441MHz -CH39 -1Mbps | | |

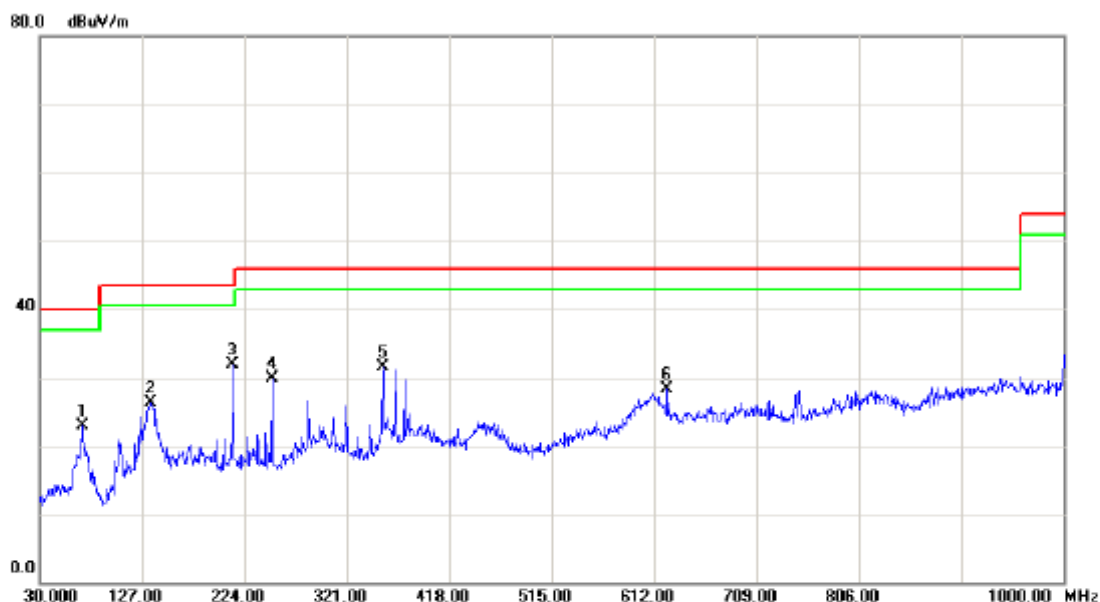

| No. | Mk. | Freq. MHz | Reading Level dBuV | Correct Factor dB | Measure- ment dBuV/m | Limit dBuV/m | Over dB | Detector | Comment |
|-----|-----|--------------|--------------------------|-------------------------|----------------------------|-----------------|------------|----------|---------|
| 1 | | 70.7400 | 39.29 | -16.37 | 22.92 | 40.00 | -17.08 | peak | |
| 2 | | 134.7600 | 39.76 | -13.55 | 26.21 | 43.50 | -17.29 | peak | |
| 3 | * | 213.3300 | 47.14 | -15.17 | 31.97 | 43.50 | -11.53 | peak | |
| 4 | | 250.1900 | 44.92 | -14.97 | 29.95 | 46.00 | -16.05 | peak | |
| 5 | | 354.9500 | 42.79 | -11.30 | 31.49 | 46.00 | -14.51 | peak | |
| 6 | | 624.6100 | 35.15 | -6.86 | 28.29 | 46.00 | -17.71 | peak | |



| | | | |
|--------------|-----------------------------|--------------------|----------|
| EUT: | Cisco TelePresence Touch 10 | Model Name: | TTC5-09 |
| Temperature: | 28 °C | Relative Humidity: | 56 % |
| Test Power: | DC 48V | Polarization: | Vertical |
| Test Mode: | TX 2480MHz -CH78 -1Mbps | | |

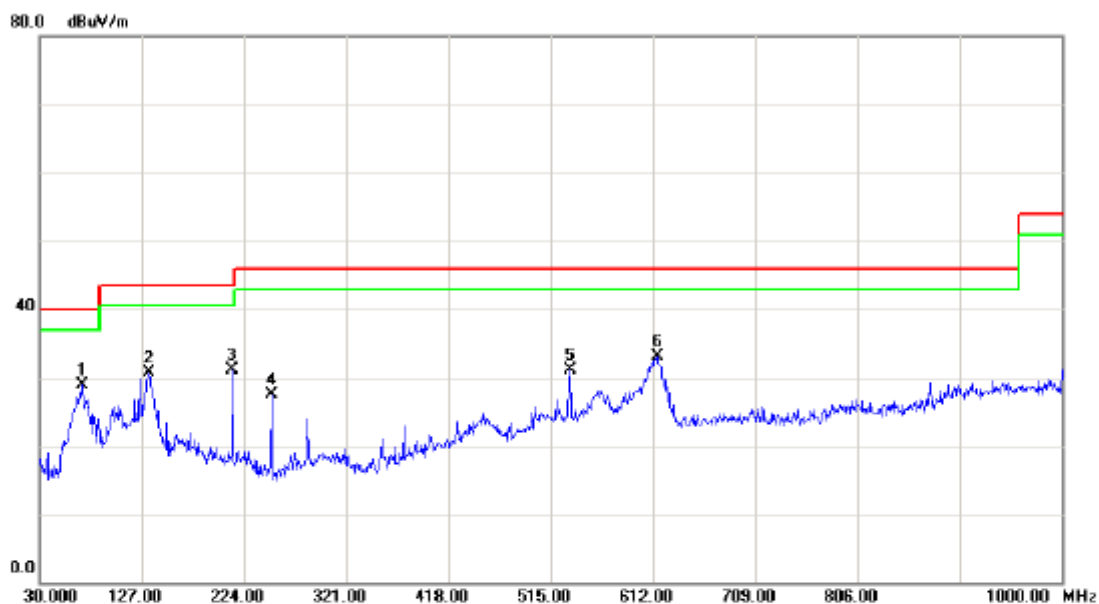

| No. | Mk. | Freq. MHz | Reading Level dBuV | Correct Factor dB | Measure- ment dBuV/m | Limit dBuV/m | Over dB | Detector | Comment |
|-----|-----|--------------|--------------------------|-------------------------|----------------------------|-----------------|------------|----------|---------|
| 1 | * | 70.7400 | 45.19 | -16.37 | 28.82 | 40.00 | -11.18 | peak | |
| 2 | | 133.7900 | 44.19 | -13.50 | 30.69 | 43.50 | -12.81 | peak | |
| 3 | | 213.3300 | 46.30 | -15.17 | 31.13 | 43.50 | -12.37 | peak | |
| 4 | | 250.1900 | 42.47 | -14.97 | 27.50 | 46.00 | -18.50 | peak | |
| 5 | | 533.4300 | 39.73 | -8.55 | 31.18 | 46.00 | -14.82 | peak | |
| 6 | | 615.8800 | 40.45 | -7.30 | 33.15 | 46.00 | -12.85 | peak | |



| | | | |
|--------------|-----------------------------|--------------------|------------|
| EUT: | Cisco TelePresence Touch 10 | Model Name: | TTC5-09 |
| Temperature: | 28 °C | Relative Humidity: | 56 % |
| Test Power: | DC 48V | Polarization: | Horizontal |
| Test Mode: | TX 2480MHz -CH78 -1Mbps | | |

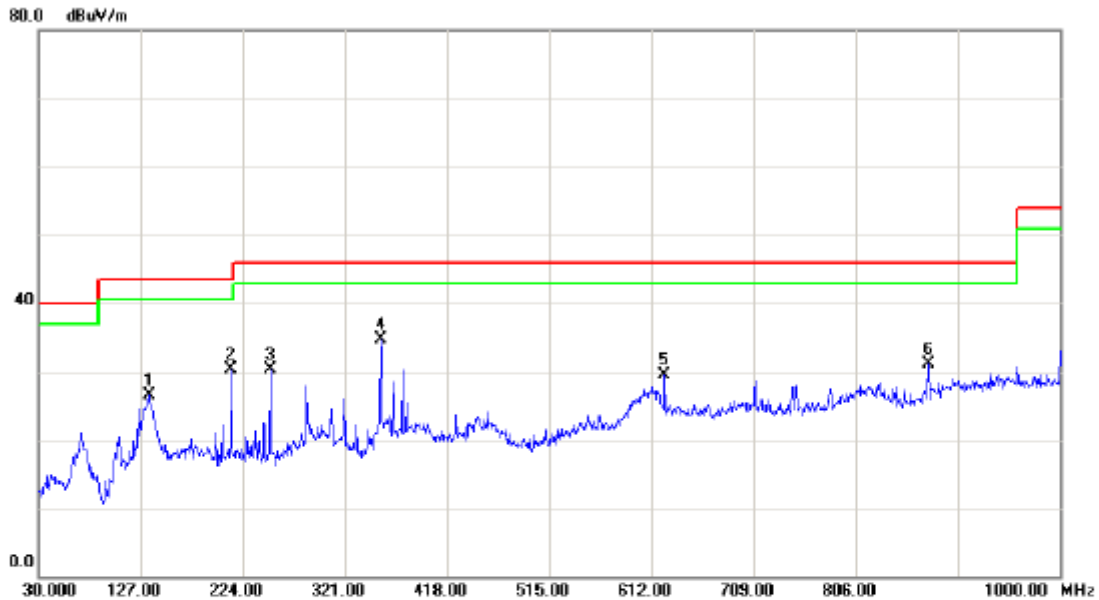

| No. | Mk. | Freq. MHz | Reading Level dBuV | Correct Factor dB | Measure- ment dBuV/m | Limit dBuV/m | Over dB | Detector | Comment |
|-----|-----|--------------|--------------------------|-------------------------|----------------------------|-----------------|------------|----------|---------|
| 1 | | 134.7600 | 39.96 | -13.55 | 26.41 | 43.50 | -17.09 | peak | |
| 2 | | 213.3300 | 45.38 | -15.17 | 30.21 | 43.50 | -13.29 | peak | |
| 3 | | 250.1900 | 45.21 | -14.97 | 30.24 | 46.00 | -15.76 | peak | |
| 4 | * | 354.9500 | 46.09 | -11.30 | 34.79 | 46.00 | -11.21 | peak | |
| 5 | | 624.6100 | 36.35 | -6.86 | 29.49 | 46.00 | -16.51 | peak | |
| 6 | | 874.8700 | 33.60 | -2.48 | 31.12 | 46.00 | -14.88 | peak | |



4.2.8 TEST RESULTS (ABOVE 1000 MHZ)

| | | | |
|--------------|-----------------------------|--------------------|---------|
| EUT: | Cisco TelePresence Touch 10 | Model Name: | TTC5-09 |
| Temperature: | 25 °C | Relative Humidity: | 58 % |
| Pressure: | 1010 hPa | Test Voltage: | DC 48V |
| Test Mode: | TX 2402MHz -CH00 -1Mbps | | |

| Freq. (MHz) | Ant.Pol. H/V | Reading | | Ant./CF CF(dB) | Act. | | Limit | | Note |
|----------------|-----------------|----------------|--------------|-------------------|------------------|----------------|------------------|----------------|------------|
| | | Peak (dBuV) | AV (dBuV) | | Peak (dBuV/m) | AV (dBuV/m) | Peak (dBuV/m) | AV (dBuV/m) | |
| 2390.00 | V | 23.55 | 13.57 | 34.09 | 57.64 | 47.66 | 74.00 | 54.00 | X/E |
| 2401.85 | V | 70.93 | 60.70 | 34.12 | 105.05 | 94.82 | | | X/F |
| 4803.81 | V | 42.81 | 31.33 | 6.38 | 49.19 | 37.71 | 74.00 | 54.00 | X/H |

Remark:

- (1) All readings are Peak unless otherwise stated QP in column of 『Note』 . Peak denotes that the Peak reading compliance with the QP Limits and then QP Mode measurement didn't perform.
- (2) Measuring frequency range from 30MHz to 1000MHz or the 10th harmonic of highest fundamental frequency. "F" denotes fundamental frequency;"H" denotes spurious frequency. "E" denotes band edge frequency. (This judgment method includes the Band Edge Requirement.)
- (3) Radiated emissions measured in frequency range above 1000MHz were made with an instrument using Peak detector mode and AV detector mode of the emission
- (4) Data of measurement within this frequency range shown "*" in the table above means the reading of emissions are attenuated more than 20dB below the permissible limits or the field strength is too small to be measured.
- (5) A preamp and high pass filter were used for this test in order to provide sufficient measurement sensitivity.
- (6) EUT Orthogonal Axis:
"X" - denotes Laid on Table ; "Y" - denotes Vertical Stand ; "Z" - denotes Side Stand
- (7) During the measurements above 1 GHz it is taken care of that the EUT is always within the 3 dB cone of radiation BW of the used antenna



TX CH00(Above 1000 MHz, Vertical)

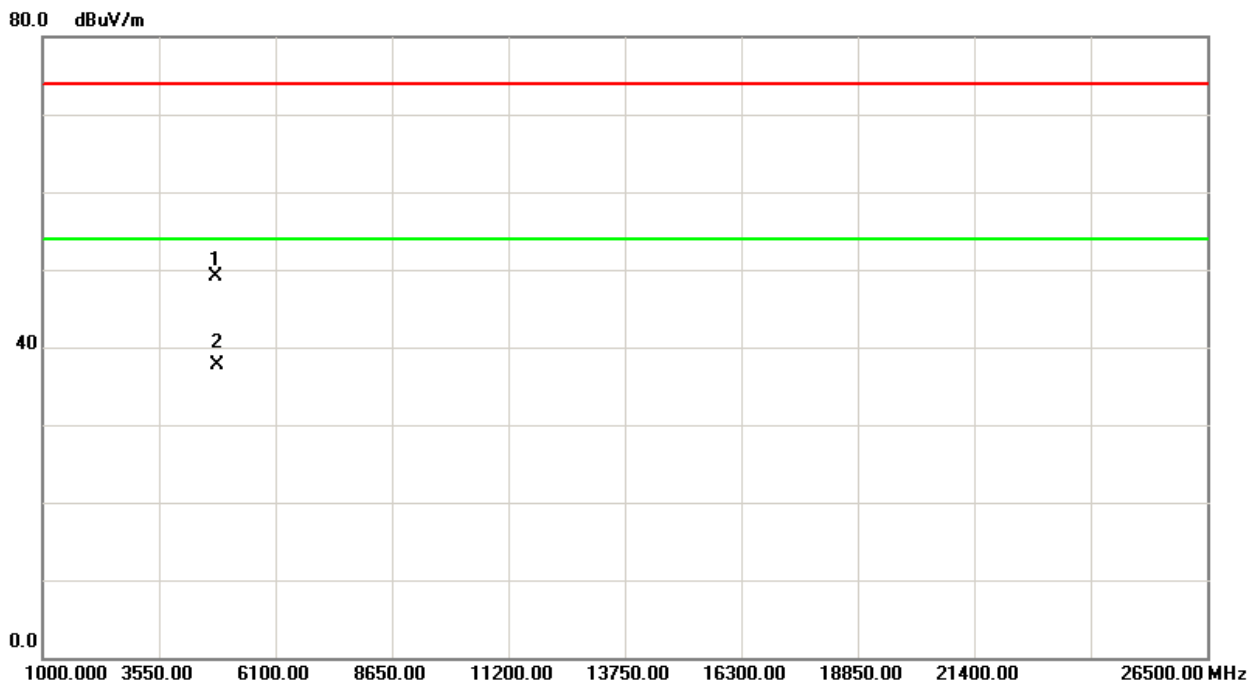
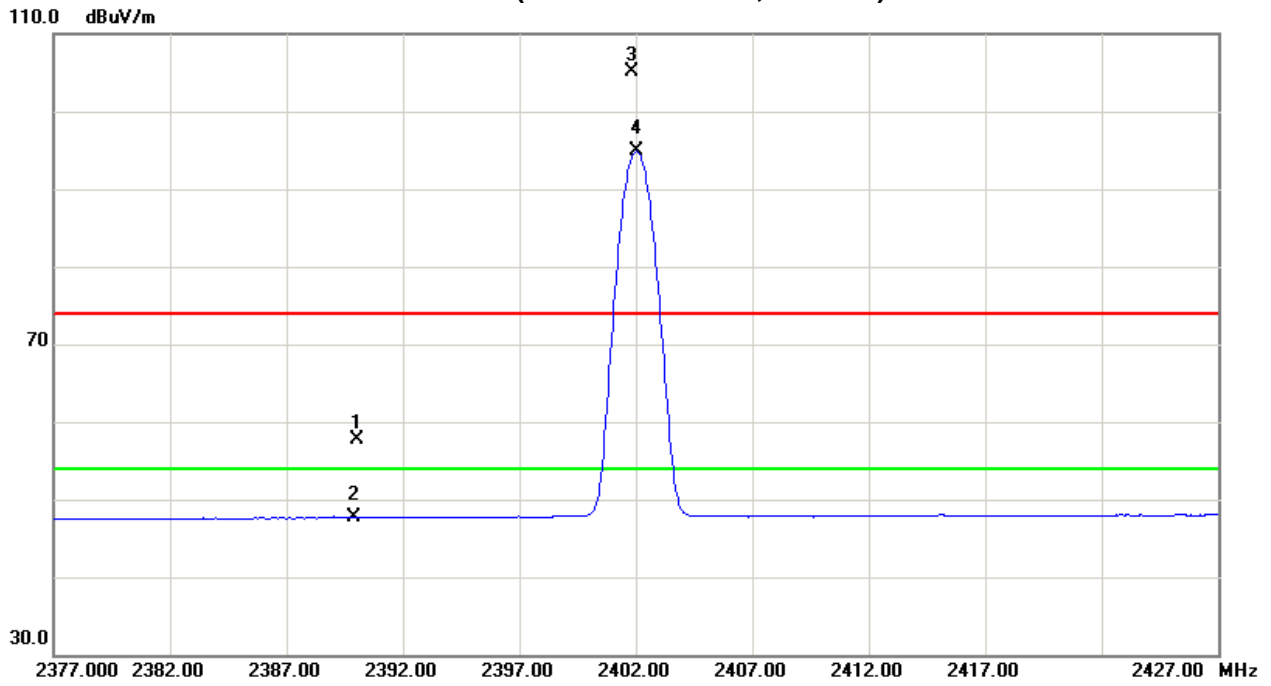



| | | | |
|--------------|-----------------------------|--------------------|---------|
| EUT: | Cisco TelePresence Touch 10 | Model Name: | TTC5-09 |
| Temperature: | 25 °C | Relative Humidity: | 58 % |
| Pressure: | 1010 hPa | Test Voltage: | DC 48V |
| Test Mode: | TX 2402MHz -CH00 -1Mbps | | |

| Freq. (MHz) | Ant.Pol. H/V | Reading | | Ant./CF CF(dB) | Act. | | Limit | | Note |
|----------------|-----------------|----------------|--------------|-------------------|------------------|----------------|------------------|----------------|------------|
| | | Peak (dBuV) | AV (dBuV) | | Peak (dBuV/m) | AV (dBuV/m) | Peak (dBuV/m) | AV (dBuV/m) | |
| 2390.00 | H | 22.73 | 13.56 | 34.09 | 56.82 | 47.65 | 74.00 | 54.00 | X/E |
| 2402.05 | H | 72.10 | 61.80 | 34.12 | 106.22 | 95.92 | | | X/F |
| 4804.47 | H | 41.80 | 30.12 | 6.38 | 48.18 | 36.50 | 74.00 | 54.00 | X/H |

Remark:

- (1) All readings are Peak unless otherwise stated QP in column of 『Note』 . Peak denotes that the Peak reading compliance with the QP Limits and then QP Mode measurement didn't perform.
- (2) Measuring frequency range from 30MHz to 1000MHz or the 10th harmonic of highest fundamental frequency. "F" denotes fundamental frequency;"H" denotes spurious frequency. "E" denotes band edge frequency. (This judgment method includes the Band Edge Requirement.)
- (3) Radiated emissions measured in frequency range above 1000MHz were made with an instrument using Peak detector mode and AV detector mode of the emission
- (4) Data of measurement within this frequency range shown "*" in the table above means the reading of emissions are attenuated more than 20dB below the permissible limits or the field strength is too small to be measured.
- (5) A preamp and high pass filter were used for this test in order to provide sufficient measurement sensitivity.
- (6) EUT Orthogonal Axis:
"X" - denotes Laid on Table ; "Y" - denotes Vertical Stand ; "Z" - denotes Side Stand
- (7) During the measurements above 1 GHz it is taken care of that the EUT is always within the 3 dB cone of radiation BW of the used antenna



TX CH00(Above 1000 MHz, Horizontal)

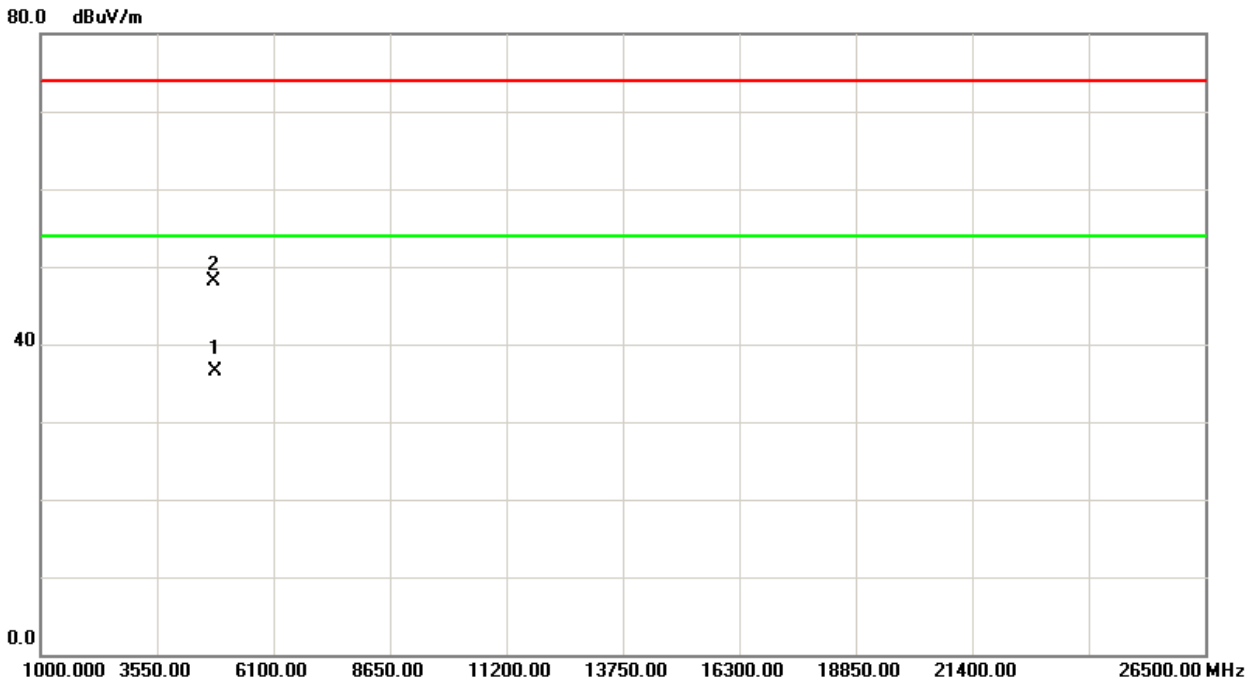
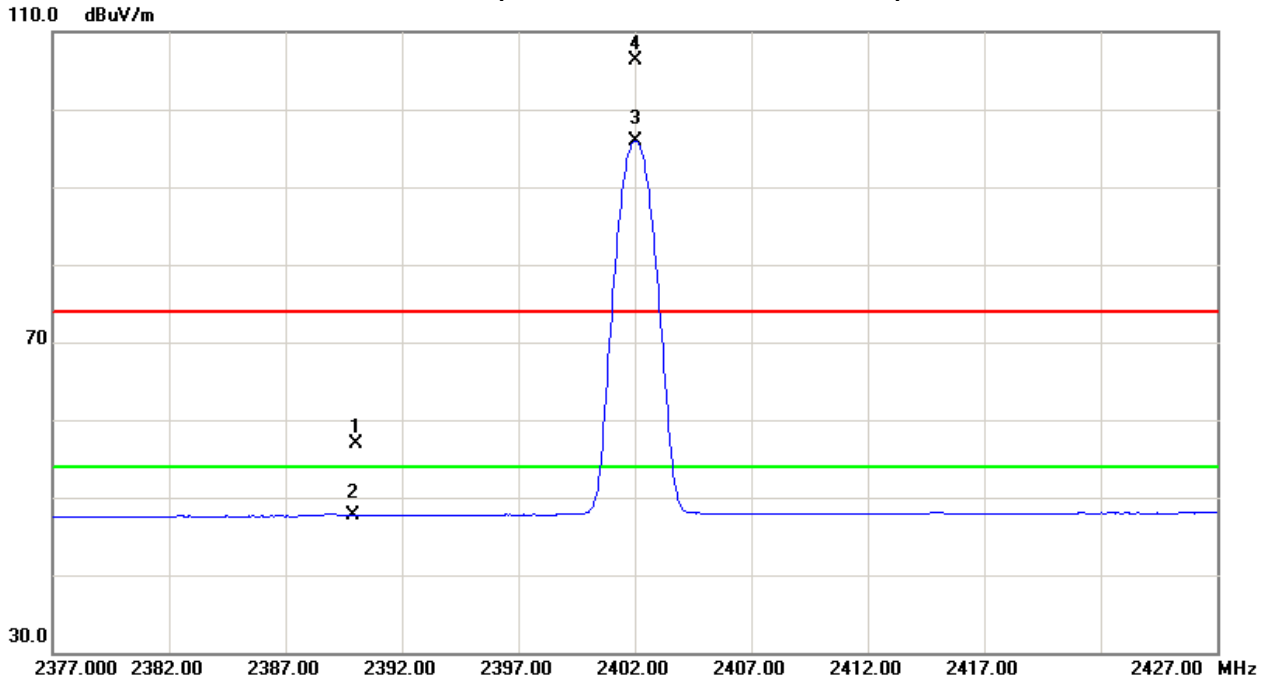



| | | | |
|--------------|-----------------------------|--------------------|---------|
| EUT: | Cisco TelePresence Touch 10 | Model Name: | TTC5-09 |
| Temperature: | 25 °C | Relative Humidity: | 58 % |
| Pressure: | 1010 hPa | Test Voltage: | DC 48V |
| Test Mode: | TX 2441MHz -CH39 -1Mbps | | |

| Freq. (MHz) | Ant.Pol. H/V | Reading | | Ant./CF CF(dB) | Act. | | Limit | | Note |
|----------------|-----------------|----------------|--------------|-------------------|------------------|----------------|------------------|----------------|------------|
| | | Peak (dBuV) | AV (dBuV) | | Peak (dBuV/m) | AV (dBuV/m) | Peak (dBuV/m) | AV (dBuV/m) | |
| 2441.20 | V | 69.25 | 59.09 | 34.25 | 103.50 | 93.34 | | | X/F |
| 4882.02 | V | 43.06 | 31.62 | 6.61 | 49.67 | 38.23 | 74.00 | 54.00 | X/H |

Remark:

- (1) All readings are Peak unless otherwise stated QP in column of 『Note』 . Peak denotes that the Peak reading compliance with the QP Limits and then QP Mode measurement didn't perform.
- (2) Measuring frequency range from 30MHz to 1000MHz or the 10th harmonic of highest fundamental frequency. "F" denotes fundamental frequency;"H" denotes spurious frequency. "E" denotes band edge frequency. (This judgment method includes the Band Edge Requirement.)
- (3) Radiated emissions measured in frequency range above 1000MHz were made with an instrument using Peak detector mode and AV detector mode of the emission
- (4) Data of measurement within this frequency range shown "*" in the table above means the reading of emissions are attenuated more than 20dB below the permissible limits or the field strength is too small to be measured.
- (5) A preamp and high pass filter were used for this test in order to provide sufficient measurement sensitivity.
- (6) EUT Orthogonal Axis:
"X" - denotes Laid on Table ; "Y" - denotes Vertical Stand ; "Z" - denotes Side Stand
- (7) During the measurements above 1 GHz it is taken care of that the EUT is always within the 3 dB cone of radiation BW of the used antenna



TX CH39 (Above 1000 MHz, Vertical)

110.0 dBuV/m

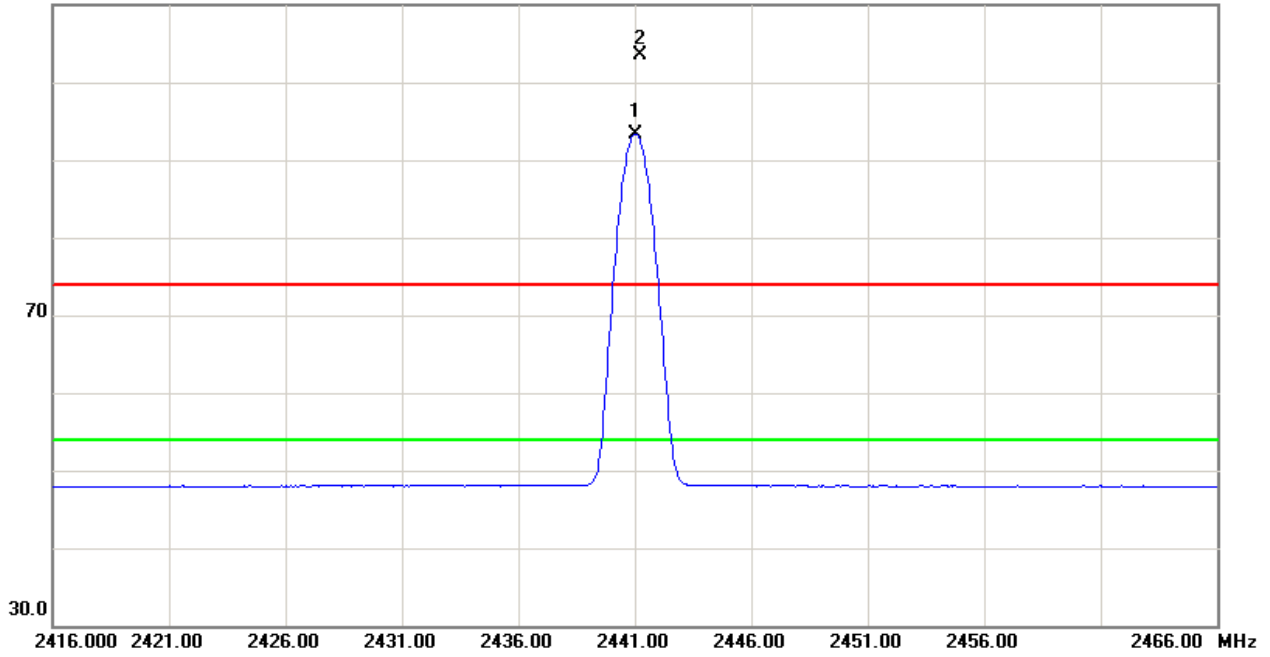

80.0 dBuV/m

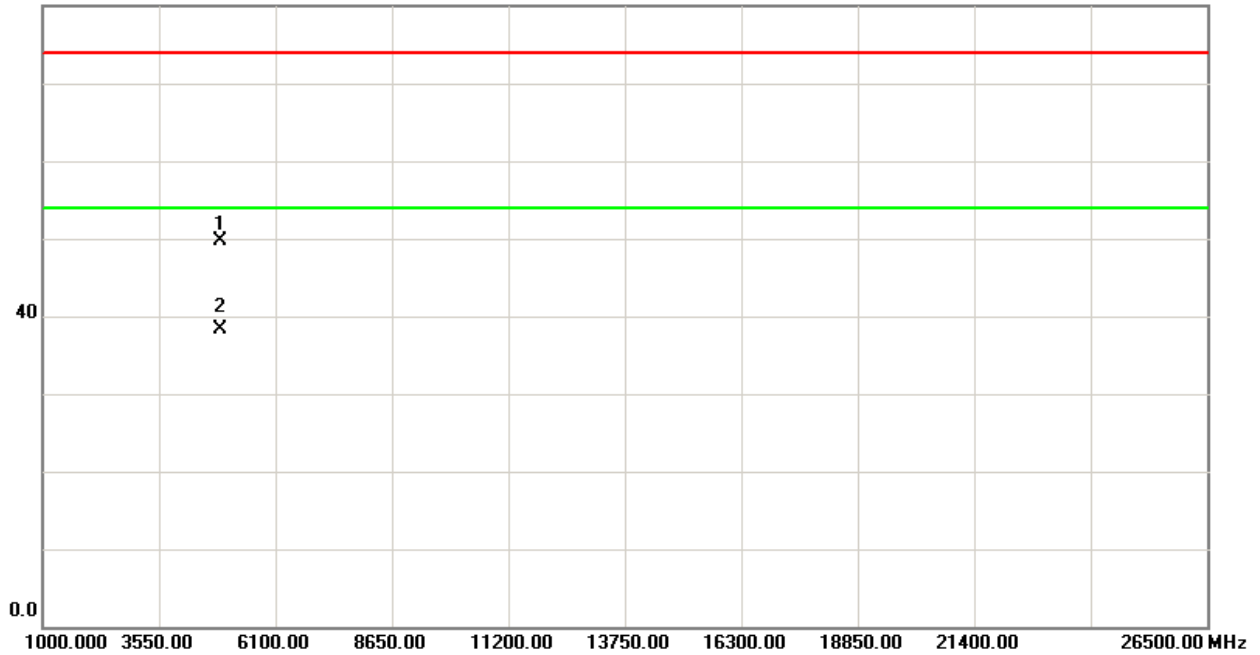



| | | | |
|--------------|-----------------------------|--------------------|---------|
| EUT: | Cisco TelePresence Touch 10 | Model Name: | TTC5-09 |
| Temperature: | 25 °C | Relative Humidity: | 58 % |
| Pressure: | 1010 hPa | Test Voltage: | DC 48V |
| Test Mode: | TX 2441MHz -CH39 -1Mbps | | |

| Freq. (MHz) | Ant.Pol. H/V | Reading | | Ant./CF CF(dB) | Act. | | Limit | | Note |
|----------------|-----------------|----------------|--------------|-------------------|------------------|----------------|------------------|----------------|------------|
| | | Peak (dBuV) | AV (dBuV) | | Peak (dBuV/m) | AV (dBuV/m) | Peak (dBuV/m) | AV (dBuV/m) | |
| 2441.20 | H | 71.30 | 61.02 | 34.25 | 105.55 | 95.27 | | | X/F |
| 4882.08 | H | 42.19 | 30.35 | 6.61 | 48.80 | 36.96 | 74.00 | 54.00 | X/H |

Remark:

- (1) All readings are Peak unless otherwise stated QP in column of 『Note』 . Peak denotes that the Peak reading compliance with the QP Limits and then QP Mode measurement didn't perform.
- (2) Measuring frequency range from 30MHz to 1000MHz or the 10th harmonic of highest fundamental frequency. "F" denotes fundamental frequency;"H" denotes spurious frequency. "E" denotes band edge frequency. (This judgment method includes the Band Edge Requirement.)
- (3) Radiated emissions measured in frequency range above 1000MHz were made with an instrument using Peak detector mode and AV detector mode of the emission
- (4) Data of measurement within this frequency range shown "*" in the table above means the reading of emissions are attenuated more than 20dB below the permissible limits or the field strength is too small to be measured.
- (5) A preamp and high pass filter were used for this test in order to provide sufficient measurement sensitivity.
- (6) EUT Orthogonal Axis:
"X" - denotes Laid on Table ; "Y" - denotes Vertical Stand ; "Z" - denotes Side Stand
- (7) During the measurements above 1 GHz it is taken care of that the EUT is always within the 3 dB cone of radiation BW of the used antenna



TX CH39 (Above 1000 MHz, Horizontal)

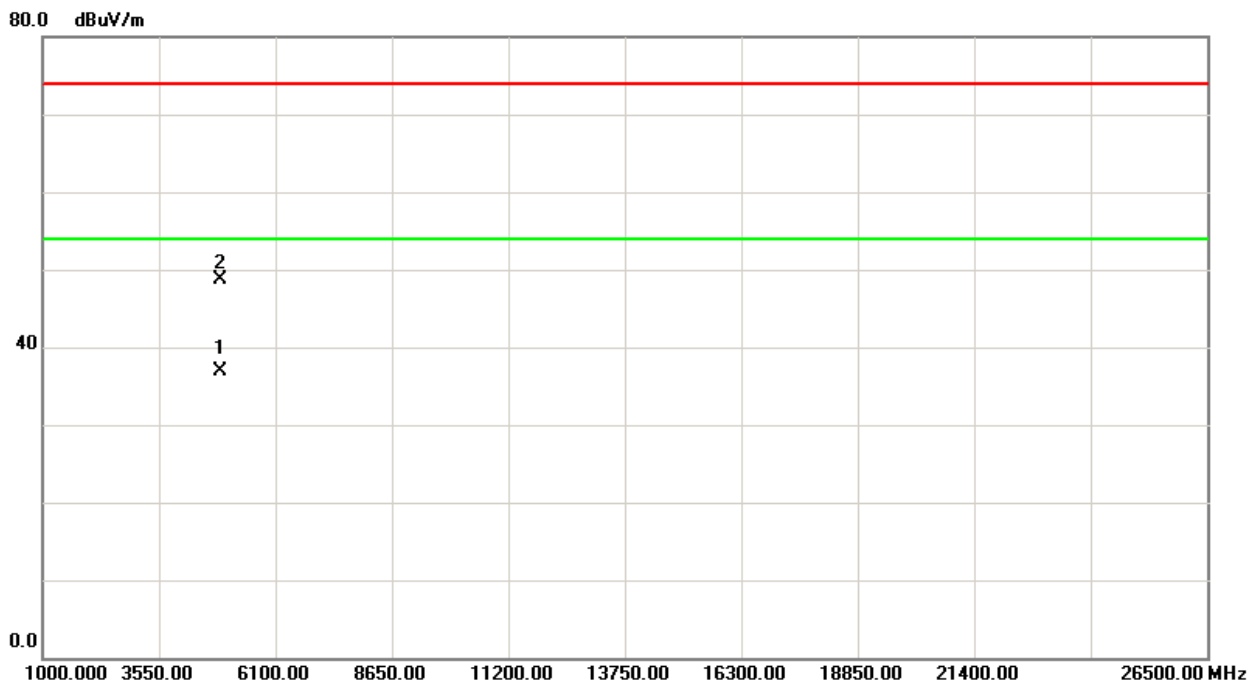
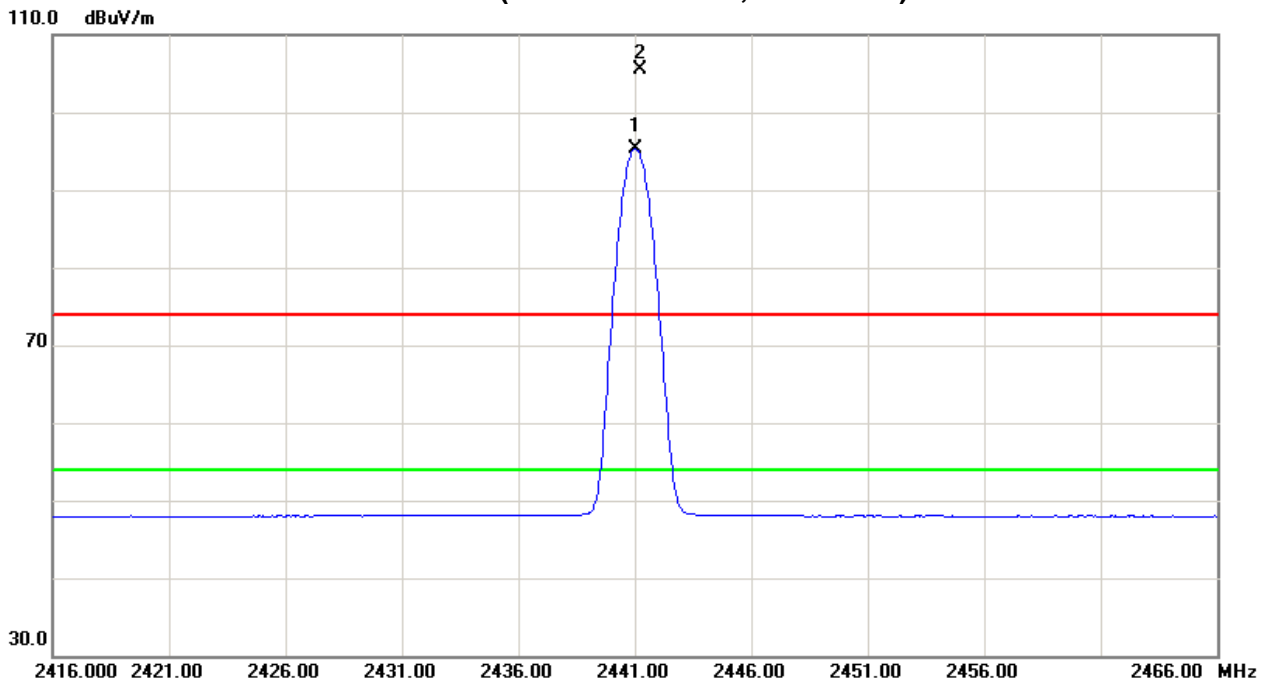



| | | | |
|--------------|-----------------------------|--------------------|---------|
| EUT: | Cisco TelePresence Touch 10 | Model Name: | TTC5-09 |
| Temperature: | 25 °C | Relative Humidity: | 58 % |
| Pressure: | 1010 hPa | Test Voltage: | DC 48V |
| Test Mode: | TX 2480MHz -CH78 -1Mbps | | |

| Freq. | Ant.Pol. | Reading | | Ant./CF | Act. | | Limit | | Note |
|----------------|----------|--------------|--------------|--------------|---------------|--------------|----------|----------|------------|
| | | Peak | AV | | Peak | AV | Peak | AV | |
| (MHz) | H/V | (dBuV) | (dBuV) | CF(dB) | (dBuV/m) | (dBuV/m) | (dBuV/m) | (dBuV/m) | |
| 2480.20 | V | 69.65 | 59.45 | 34.36 | 104.01 | 93.81 | | | X/F |
| 2483.50 | V | 23.38 | 13.58 | 34.37 | 57.75 | 47.95 | 74.00 | 54.00 | X/E |
| 4960.12 | V | 41.88 | 30.26 | 6.83 | 48.71 | 37.09 | 74.00 | 54.00 | X/H |

Remark:

- (1) All readings are Peak unless otherwise stated QP in column of 『Note』 . Peak denotes that the Peak reading compliance with the QP Limits and then QP Mode measurement didn't perform.
- (2) Measuring frequency range from 30MHz to 1000MHz or the 10th harmonic of highest fundamental frequency. "F" denotes fundamental frequency;"H" denotes spurious frequency. "E" denotes band edge frequency. (This judgment method includes the Band Edge Requirement.)
- (3) Radiated emissions measured in frequency range above 1000MHz were made with an instrument using Peak detector mode and AV detector mode of the emission
- (4) Data of measurement within this frequency range shown "*" in the table above means the reading of emissions are attenuated more than 20dB below the permissible limits or the field strength is too small to be measured.
- (5) A preamp and high pass filter were used for this test in order to provide sufficient measurement sensitivity.
- (6) EUT Orthogonal Axis:
"X" - denotes Laid on Table ; "Y" - denotes Vertical Stand ; "Z" - denotes Side Stand
- (7) During the measurements above 1 GHz it is taken care of that the EUT is always within the 3 dB cone of radiation BW of the used antenna



TX CH78 (Above 1000 MHz, Vertical)

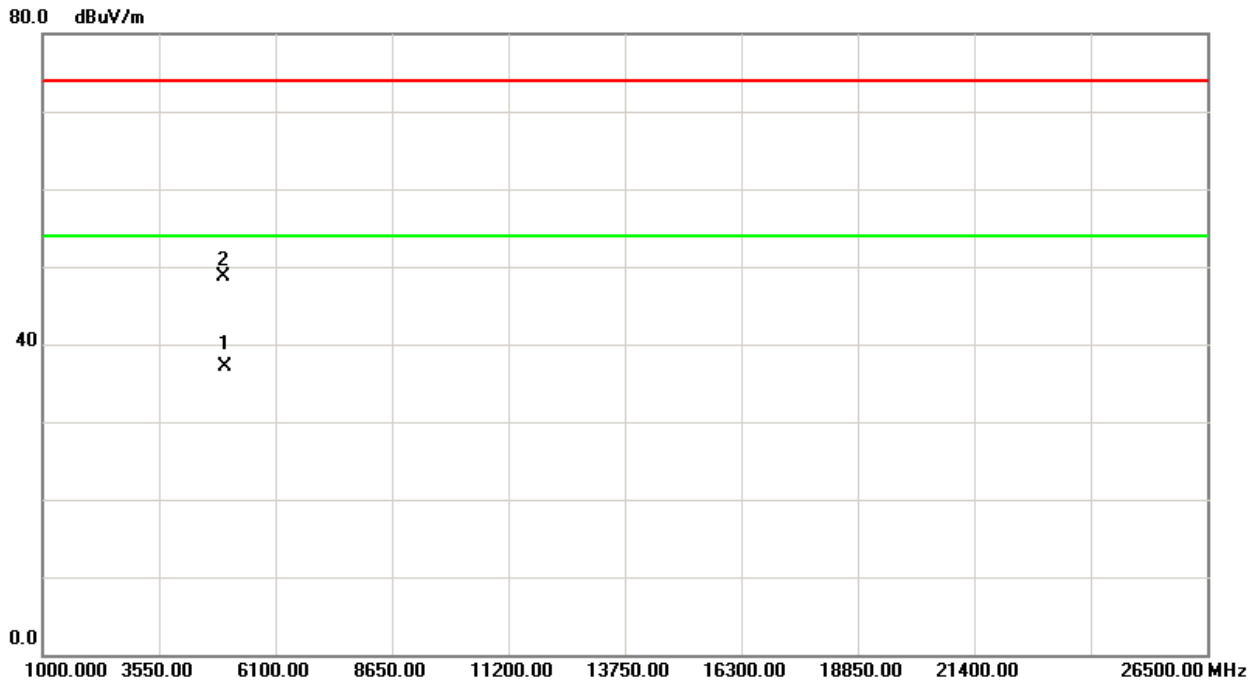
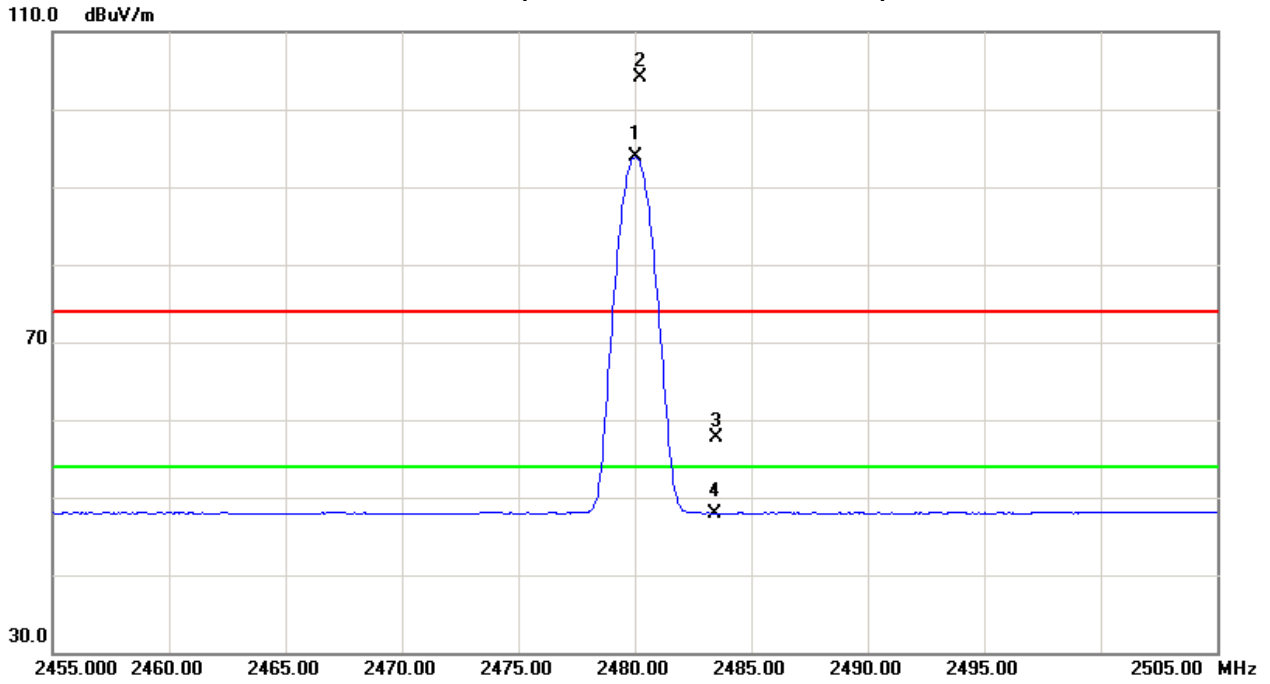



| | | | |
|--------------|-----------------------------|--------------------|---------|
| EUT: | Cisco TelePresence Touch 10 | Model Name: | TTC5-09 |
| Temperature: | 25 °C | Relative Humidity: | 58 % |
| Pressure: | 1010 hPa | Test Voltage: | DC 48V |
| Test Mode: | TX 2480MHz -CH78 -1Mbps | | |

| Freq. | Ant.Pol. | Reading | | Ant./CF | Act. | | Limit | | Note |
|----------------|----------|--------------|--------------|--------------|---------------|--------------|----------|----------|------------|
| | | Peak | AV | | Peak | AV | Peak | AV | |
| (MHz) | H/V | (dBuV) | (dBuV) | CF(dB) | (dBuV/m) | (dBuV/m) | (dBuV/m) | (dBuV/m) | |
| 2479.85 | H | 70.90 | 60.67 | 34.36 | 105.26 | 95.03 | | | X/F |
| 2483.50 | H | 22.96 | 13.68 | 34.37 | 57.33 | 48.05 | 74.00 | 54.00 | X/E |
| 4960.05 | H | 40.85 | 29.08 | 6.83 | 47.68 | 35.91 | 74.00 | 54.00 | X/H |

Remark:

- (1) All readings are Peak unless otherwise stated QP in column of 『Note』 . Peak denotes that the Peak reading compliance with the QP Limits and then QP Mode measurement didn't perform.
- (2) Measuring frequency range from 30MHz to 1000MHz or the 10th harmonic of highest fundamental frequency. "F" denotes fundamental frequency;"H" denotes spurious frequency. "E" denotes band edge frequency. (This judgment method includes the Band Edge Requirement.)
- (3) Radiated emissions measured in frequency range above 1000MHz were made with an instrument using Peak detector mode and AV detector mode of the emission
- (4) Data of measurement within this frequency range shown "*" in the table above means the reading of emissions are attenuated more than 20dB below the permissible limits or the field strength is too small to be measured.
- (5) A preamp and high pass filter were used for this test in order to provide sufficient measurement sensitivity.
- (6) EUT Orthogonal Axis:
"X" - denotes Laid on Table ; "Y" - denotes Vertical Stand ; "Z" - denotes Side Stand
- (7) During the measurements above 1 GHz it is taken care of that the EUT is always within the 3 dB cone of radiation BW of the used antenna



TX CH78 (Above 1000 MHz, Horizontal)

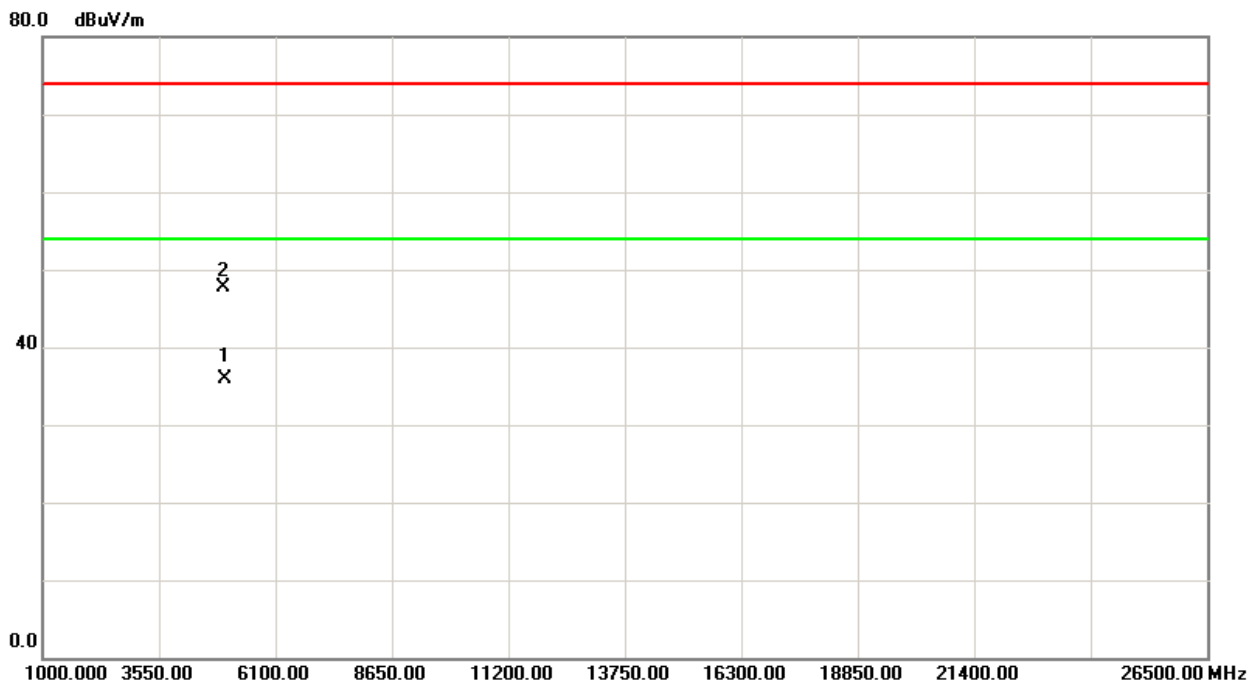
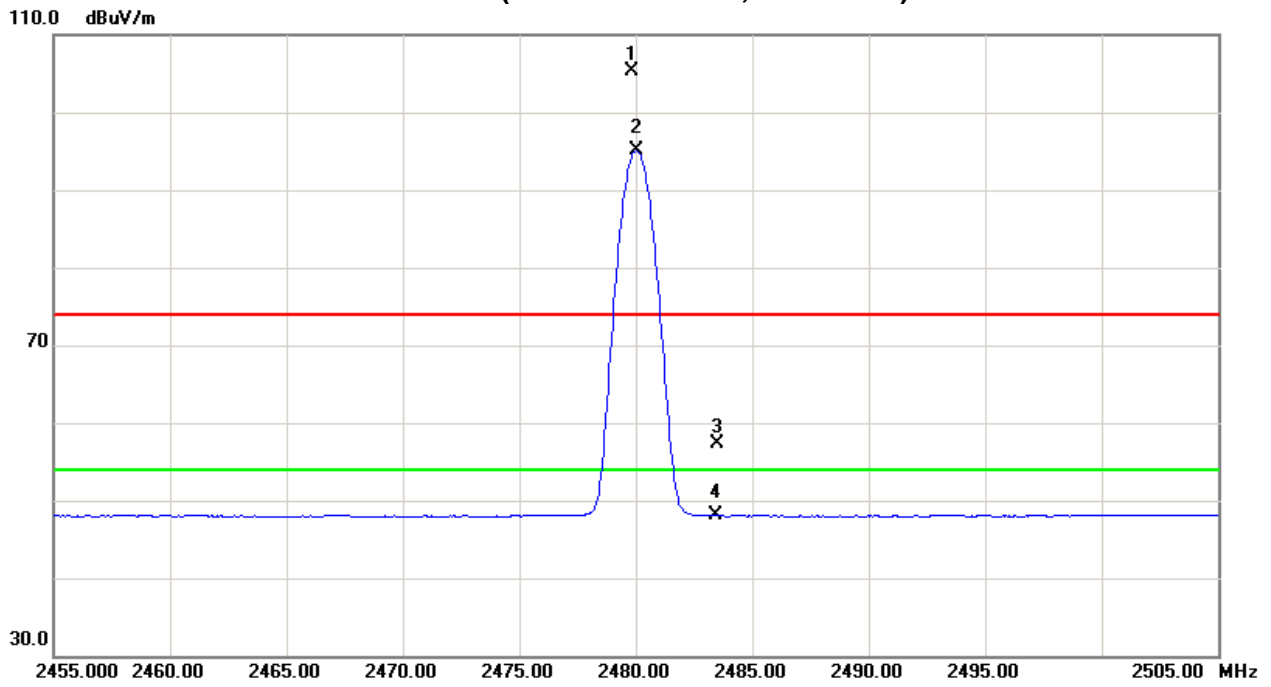



| | | | |
|--------------|-----------------------------|--------------------|---------|
| EUT: | Cisco TelePresence Touch 10 | Model Name: | TTC5-09 |
| Temperature: | 25 °C | Relative Humidity: | 58 % |
| Pressure: | 1010 hPa | Test Voltage: | DC 48V |
| Test Mode: | TX 2402MHz -CH00 -3Mbps | | |

| Freq. (MHz) | Ant.Pol. H/V | Reading | | Ant./CF CF(dB) | Act. | | Limit | | Note |
|----------------|-----------------|----------------|--------------|-------------------|------------------|----------------|------------------|----------------|------------|
| | | Peak (dBuV) | AV (dBuV) | | Peak (dBuV/m) | AV (dBuV/m) | Peak (dBuV/m) | AV (dBuV/m) | |
| 2390.00 | V | 28.08 | 13.76 | 34.09 | 62.17 | 47.85 | 74.00 | 54.00 | X/E |
| 2402.00 | V | 70.99 | 58.84 | 34.12 | 105.11 | 92.96 | | | X/F |
| 4804.11 | V | 42.35 | 29.86 | 6.38 | 48.73 | 36.24 | 74.00 | 54.00 | X/H |

Remark:

- (1) All readings are Peak unless otherwise stated QP in column of 『Note』 . Peak denotes that the Peak reading compliance with the QP Limits and then QP Mode measurement didn't perform.
- (2) Measuring frequency range from 30MHz to 1000MHz or the 10th harmonic of highest fundamental frequency. "F" denotes fundamental frequency;"H" denotes spurious frequency. "E" denotes band edge frequency. (This judgment method includes the Band Edge Requirement.)
- (3) Radiated emissions measured in frequency range above 1000MHz were made with an instrument using Peak detector mode and AV detector mode of the emission
- (4) Data of measurement within this frequency range shown "*" in the table above means the reading of emissions are attenuated more than 20dB below the permissible limits or the field strength is too small to be measured.
- (5) A preamp and high pass filter were used for this test in order to provide sufficient measurement sensitivity.
- (6) EUT Orthogonal Axis:
"X" - denotes Laid on Table ; "Y" - denotes Vertical Stand ; "Z" - denotes Side Stand
- (7) During the measurements above 1 GHz it is taken care of that the EUT is always within the 3 dB cone of radiation BW of the used antenna



TX CH00(Above 1000 MHz, Vertical)

110.0 dBuV/m

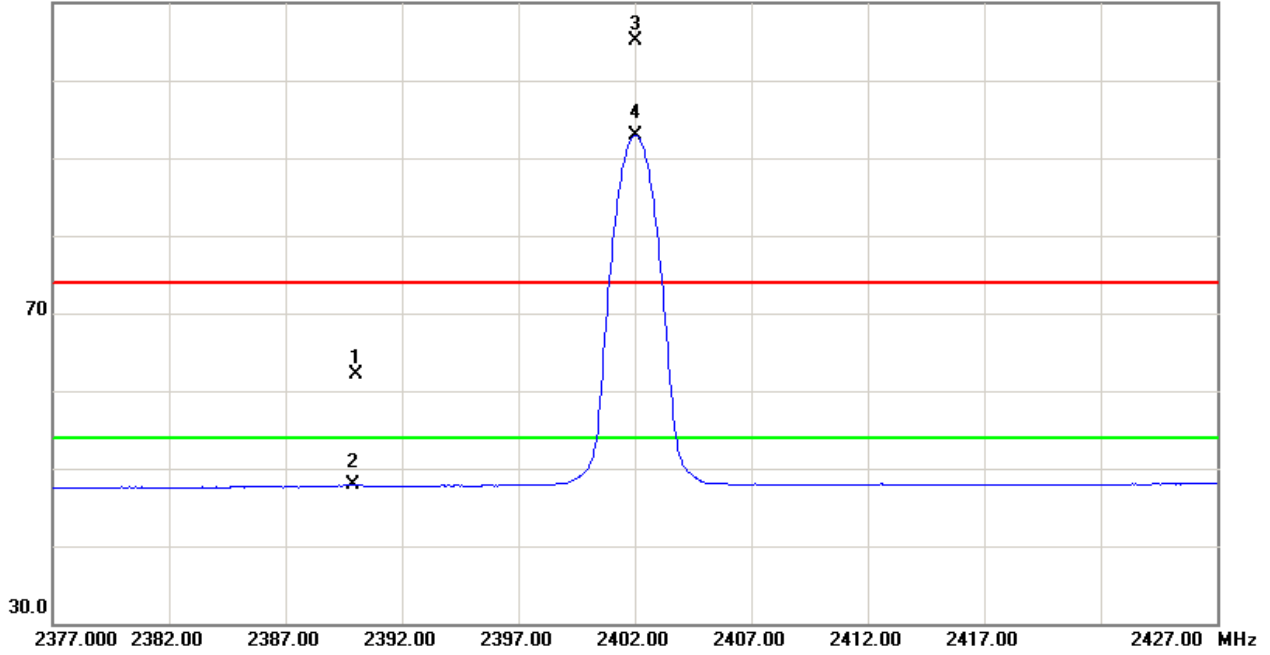

80.0 dBuV/m

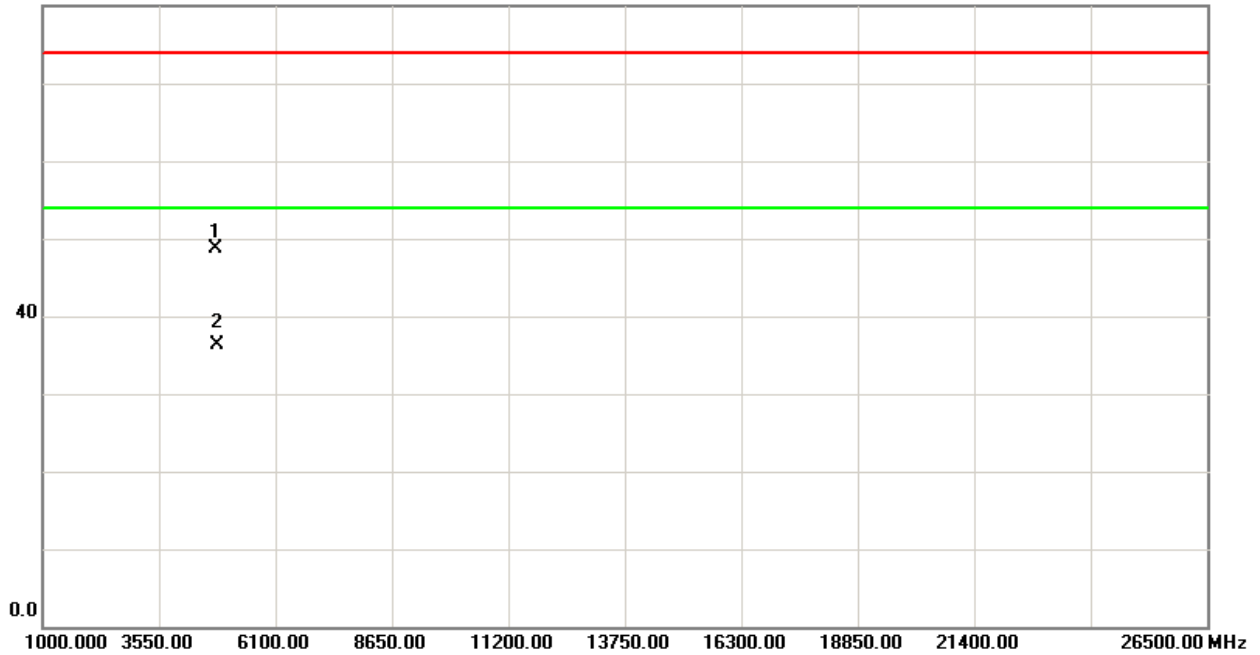



| | | | |
|--------------|-----------------------------|--------------------|---------|
| EUT: | Cisco TelePresence Touch 10 | Model Name: | TTC5-09 |
| Temperature: | 25 °C | Relative Humidity: | 58 % |
| Pressure: | 1010 hPa | Test Voltage: | DC 48V |
| Test Mode: | TX 2402MHz -CH00 -3Mbps | | |

| Freq. (MHz) | Ant.Pol. H/V | Reading | | Ant./CF CF(dB) | Act. | | Limit | | Note |
|----------------|-----------------|----------------|--------------|-------------------|------------------|----------------|------------------|----------------|------------|
| | | Peak (dBuV) | AV (dBuV) | | Peak (dBuV/m) | AV (dBuV/m) | Peak (dBuV/m) | AV (dBuV/m) | |
| 2390.00 | H | 30.14 | 13.83 | 34.09 | 64.23 | 47.92 | 74.00 | 54.00 | X/E |
| 2402.05 | H | 71.57 | 59.37 | 34.12 | 105.69 | 93.49 | | | X/F |
| 4804.20 | H | 42.38 | 29.86 | 6.38 | 48.76 | 36.24 | 74.00 | 54.00 | X/H |

Remark:

- (1) All readings are Peak unless otherwise stated QP in column of 『Note』 . Peak denotes that the Peak reading compliance with the QP Limits and then QP Mode measurement didn't perform.
- (2) Measuring frequency range from 30MHz to 1000MHz or the 10th harmonic of highest fundamental frequency. "F" denotes fundamental frequency;"H" denotes spurious frequency. "E" denotes band edge frequency. (This judgment method includes the Band Edge Requirement.)
- (3) Radiated emissions measured in frequency range above 1000MHz were made with an instrument using Peak detector mode and AV detector mode of the emission
- (4) Data of measurement within this frequency range shown "*" in the table above means the reading of emissions are attenuated more than 20dB below the permissible limits or the field strength is too small to be measured.
- (5) A preamp and high pass filter were used for this test in order to provide sufficient measurement sensitivity.
- (6) EUT Orthogonal Axis:
"X" - denotes Laid on Table ; "Y" - denotes Vertical Stand ; "Z" - denotes Side Stand
- (7) During the measurements above 1 GHz it is taken care of that the EUT is always within the 3 dB cone of radiation BW of the used antenna



TX CH00(Above 1000 MHz, Horizontal)

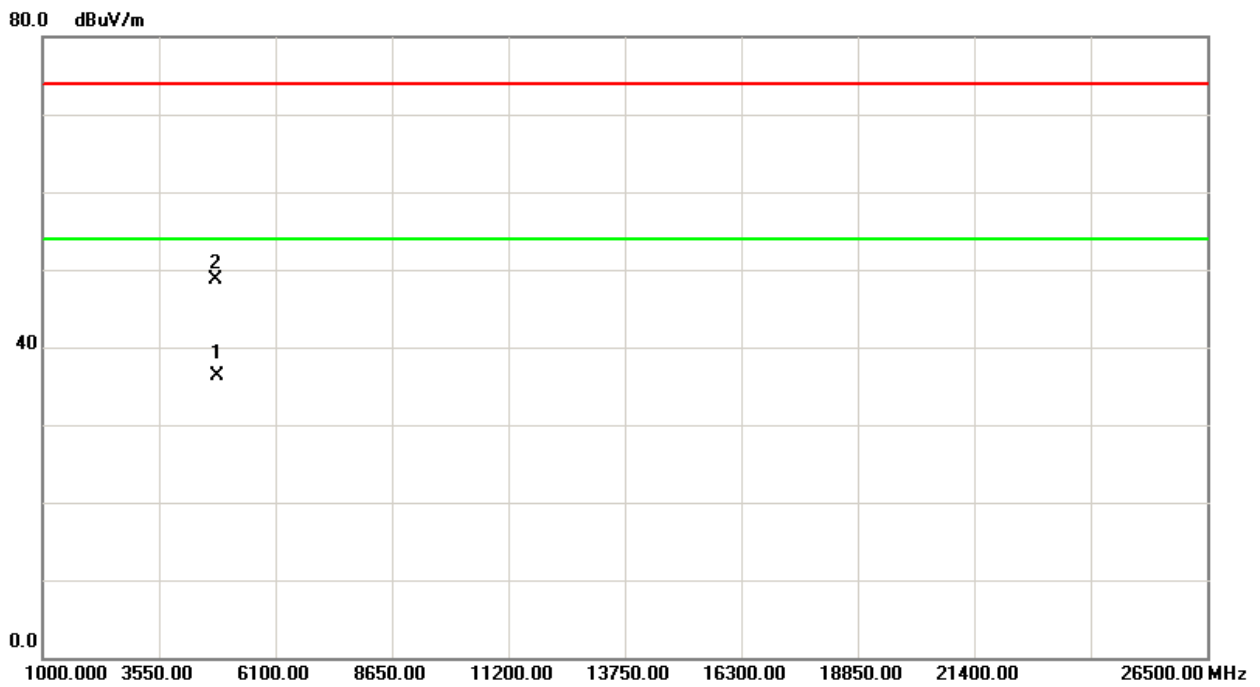
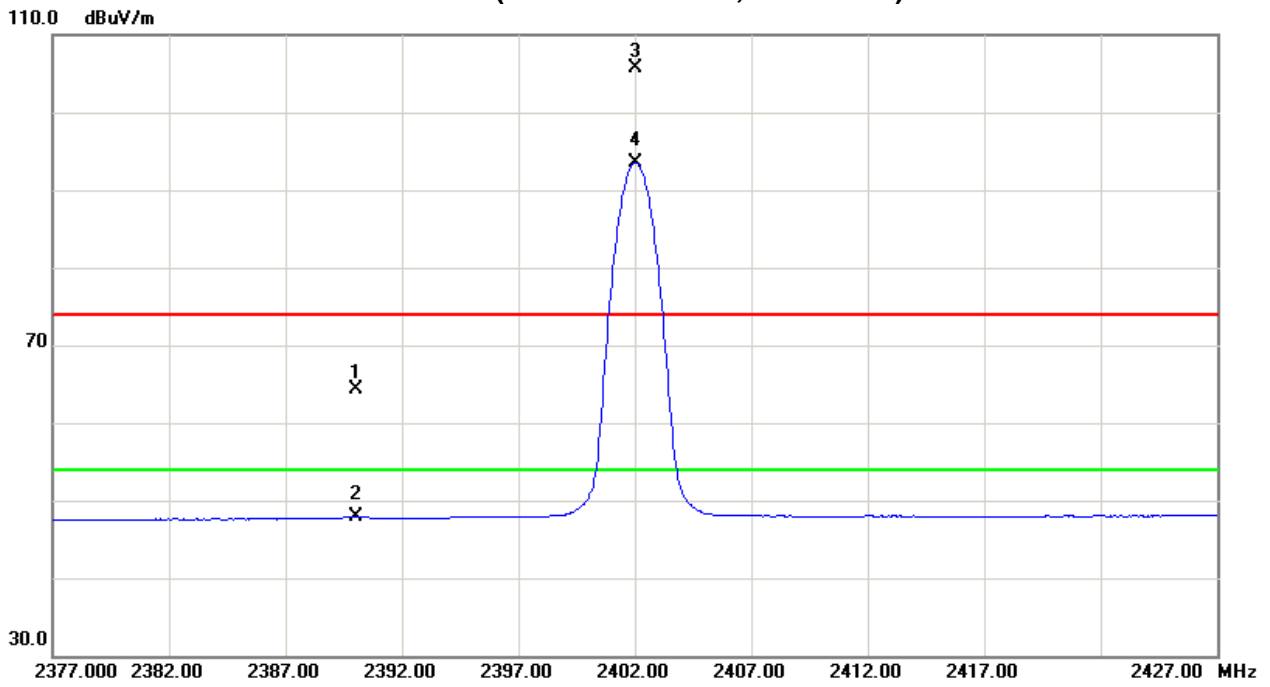



| | | | |
|--------------|-----------------------------|--------------------|---------|
| EUT: | Cisco TelePresence Touch 10 | Model Name: | TTC5-09 |
| Temperature: | 25 °C | Relative Humidity: | 58 % |
| Pressure: | 1010 hPa | Test Voltage: | DC 48V |
| Test Mode: | TX 2441MHz -CH39 -3Mbps | | |

| Freq. (MHz) | Ant.Pol. H/V | Reading | | Ant./CF CF(dB) | Act. | | Limit | | Note |
|----------------|-----------------|----------------|--------------|-------------------|------------------|----------------|------------------|----------------|------------|
| | | Peak (dBuV) | AV (dBuV) | | Peak (dBuV/m) | AV (dBuV/m) | Peak (dBuV/m) | AV (dBuV/m) | |
| 2441.00 | V | 69.77 | 57.49 | 34.25 | 104.02 | 91.74 | | | X/F |
| 4882.05 | V | 42.65 | 31.12 | 6.61 | 49.26 | 37.73 | 74.00 | 54.00 | X/H |

Remark:

- (1) All readings are Peak unless otherwise stated QP in column of 『Note』 . Peak denotes that the Peak reading compliance with the QP Limits and then QP Mode measurement didn't perform.
- (2) Measuring frequency range from 30MHz to 1000MHz or the 10th harmonic of highest fundamental frequency. "F" denotes fundamental frequency;"H" denotes spurious frequency. "E" denotes band edge frequency. (This judgment method includes the Band Edge Requirement.)
- (3) Radiated emissions measured in frequency range above 1000MHz were made with an instrument using Peak detector mode and AV detector mode of the emission
- (4) Data of measurement within this frequency range shown "*" in the table above means the reading of emissions are attenuated more than 20dB below the permissible limits or the field strength is too small to be measured.
- (5) A preamp and high pass filter were used for this test in order to provide sufficient measurement sensitivity.
- (6) EUT Orthogonal Axis:
"X" - denotes Laid on Table ; "Y" - denotes Vertical Stand ; "Z" - denotes Side Stand
- (7) During the measurements above 1 GHz it is taken care of that the EUT is always within the 3 dB cone of radiation BW of the used antenna



TX CH39 (Above 1000 MHz, Vertical)

110.0 dBuV/m

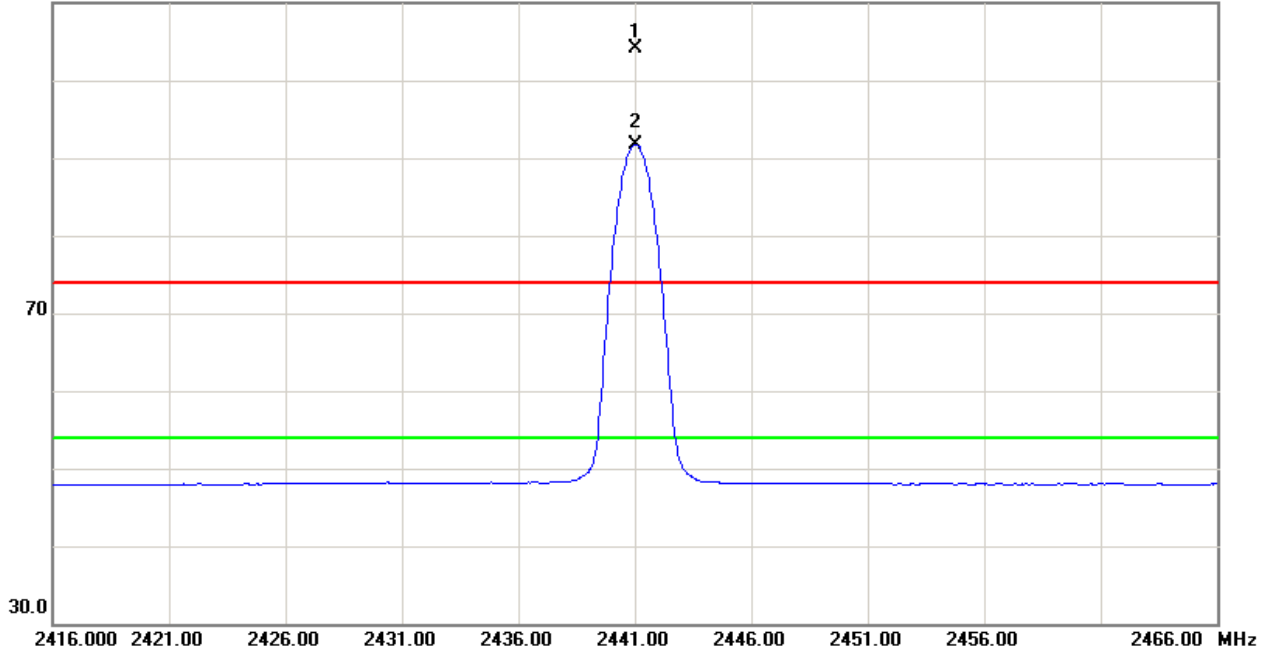

80.0 dBuV/m

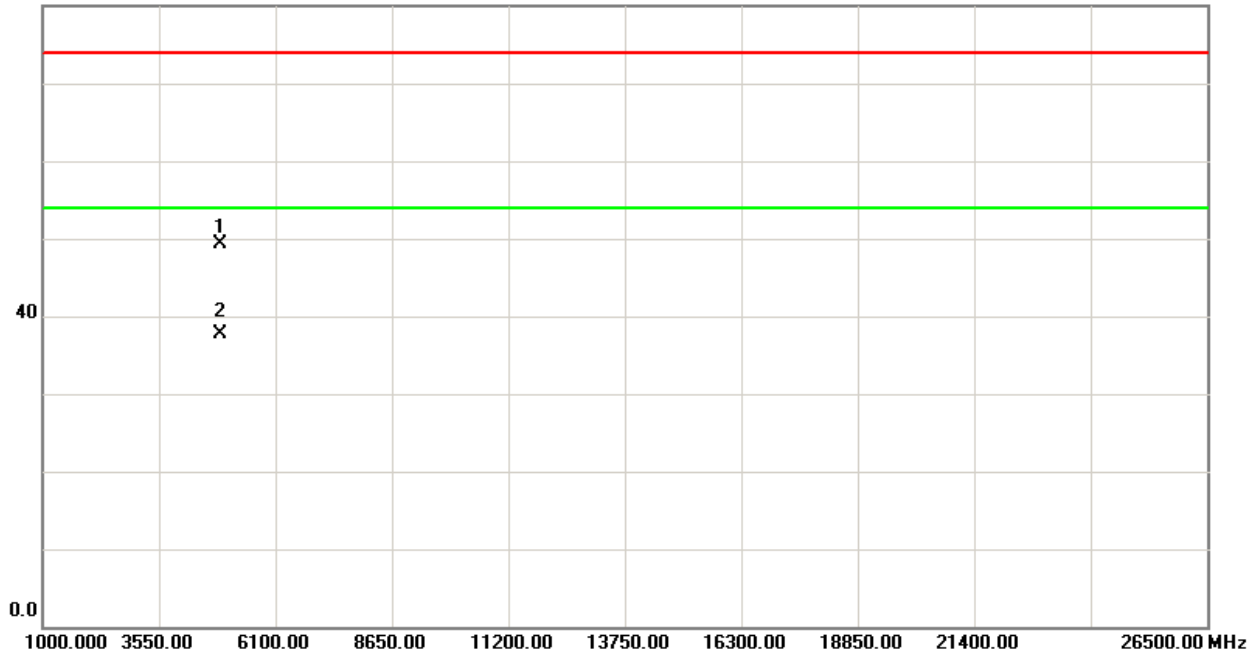



| | | | |
|--------------|-----------------------------|--------------------|---------|
| EUT: | Cisco TelePresence Touch 10 | Model Name: | TTC5-09 |
| Temperature: | 25 °C | Relative Humidity: | 58 % |
| Pressure: | 1010 hPa | Test Voltage: | DC 48V |
| Test Mode: | TX 2441MHz -CH39 -3Mbps | | |

| Freq. (MHz) | Ant.Pol. H/V | Reading | | Ant./CF CF(dB) | Act. | | Limit | | Note |
|----------------|-----------------|----------------|--------------|-------------------|------------------|----------------|------------------|----------------|------------|
| | | Peak (dBuV) | AV (dBuV) | | Peak (dBuV/m) | AV (dBuV/m) | Peak (dBuV/m) | AV (dBuV/m) | |
| 2441.00 | H | 71.09 | 58.85 | 34.25 | 105.34 | 93.10 | | | X/F |
| 4881.98 | H | 41.86 | 29.84 | 6.61 | 48.47 | 36.45 | 74.00 | 54.00 | X/H |

Remark:

- (1) All readings are Peak unless otherwise stated QP in column of 『Note』 . Peak denotes that the Peak reading compliance with the QP Limits and then QP Mode measurement didn't perform.
- (2) Measuring frequency range from 30MHz to 1000MHz or the 10th harmonic of highest fundamental frequency. "F" denotes fundamental frequency;"H" denotes spurious frequency. "E" denotes band edge frequency. (This judgment method includes the Band Edge Requirement.)
- (3) Radiated emissions measured in frequency range above 1000MHz were made with an instrument using Peak detector mode and AV detector mode of the emission
- (4) Data of measurement within this frequency range shown "*" in the table above means the reading of emissions are attenuated more than 20dB below the permissible limits or the field strength is too small to be measured.
- (5) A preamp and high pass filter were used for this test in order to provide sufficient measurement sensitivity.
- (6) EUT Orthogonal Axis:
"X" - denotes Laid on Table ; "Y" - denotes Vertical Stand ; "Z" - denotes Side Stand
- (7) During the measurements above 1 GHz it is taken care of that the EUT is always within the 3 dB cone of radiation BW of the used antenna



TX CH39 (Above 1000 MHz, Horizontal)

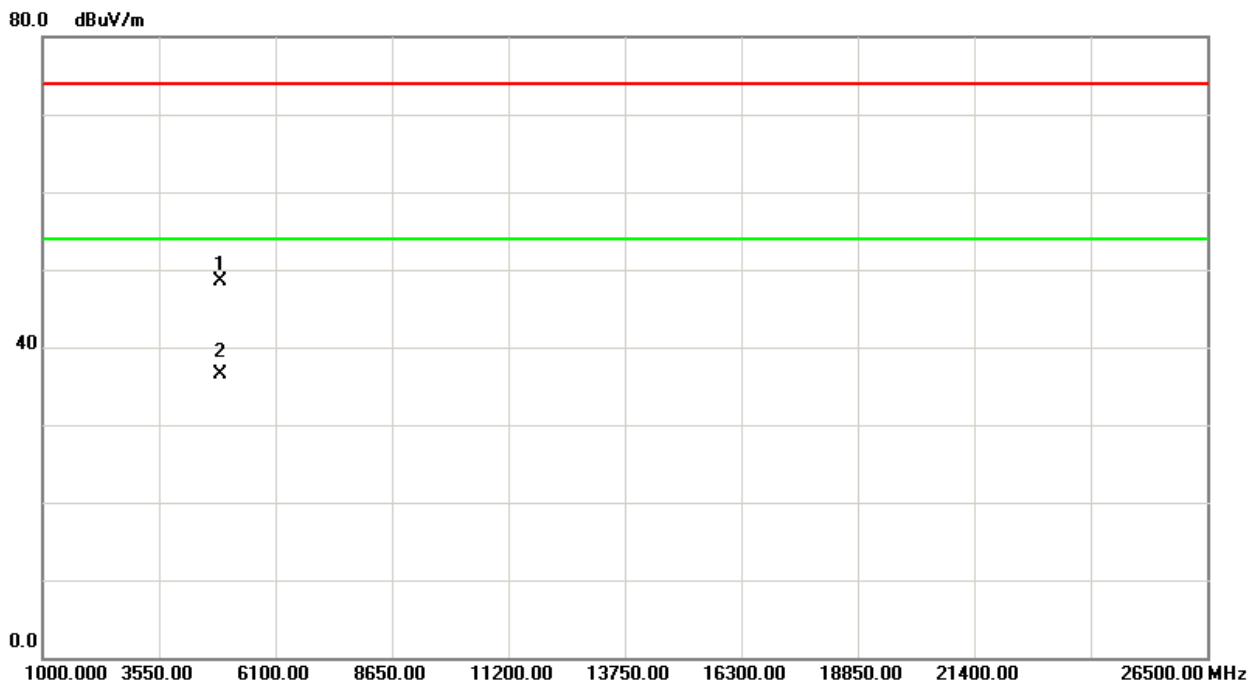
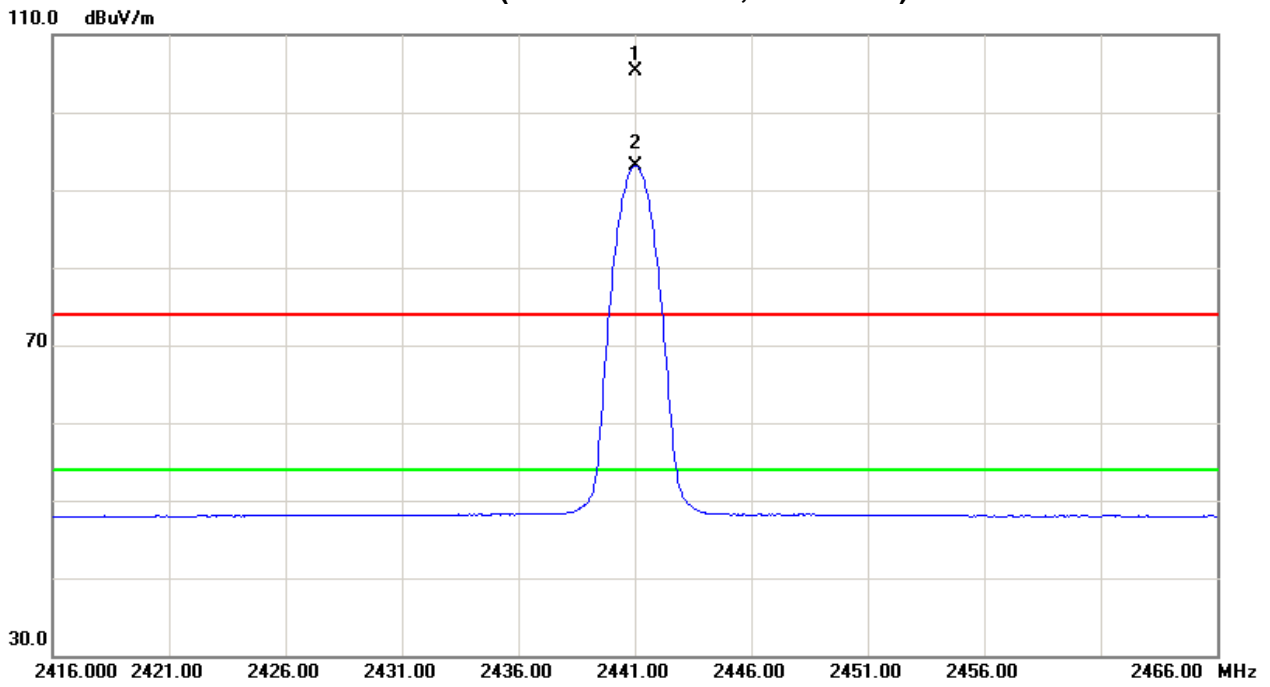



| | | | |
|--------------|-----------------------------|--------------------|---------|
| EUT: | Cisco TelePresence Touch 10 | Model Name: | TTC5-09 |
| Temperature: | 25 °C | Relative Humidity: | 58 % |
| Pressure: | 1010 hPa | Test Voltage: | DC 48V |
| Test Mode: | TX 2480MHz -CH78 -3Mbps | | |

| Freq. | Ant.Pol. | Reading | | Ant./CF | Act. | | Limit | | Note |
|----------------|----------|--------------|--------------|--------------|---------------|--------------|----------|----------|------------|
| | | Peak | AV | | Peak | AV | Peak | AV | |
| (MHz) | H/V | (dBuV) | (dBuV) | CF(dB) | (dBuV/m) | (dBuV/m) | (dBuV/m) | (dBuV/m) | |
| 2479.80 | V | 69.98 | 57.95 | 34.36 | 104.34 | 92.31 | | | X/F |
| 2483.50 | V | 25.14 | 13.74 | 34.37 | 59.51 | 48.11 | 74.00 | 54.00 | X/E |
| 4960.19 | V | 41.26 | 29.84 | 6.83 | 48.09 | 36.67 | 74.00 | 54.00 | X/H |

Remark:

- (1) All readings are Peak unless otherwise stated QP in column of 『Note』 . Peak denotes that the Peak reading compliance with the QP Limits and then QP Mode measurement didn't perform.
- (2) Measuring frequency range from 30MHz to 1000MHz or the 10th harmonic of highest fundamental frequency. "F" denotes fundamental frequency;"H" denotes spurious frequency. "E" denotes band edge frequency. (This judgment method includes the Band Edge Requirement.)
- (3) Radiated emissions measured in frequency range above 1000MHz were made with an instrument using Peak detector mode and AV detector mode of the emission
- (4) Data of measurement within this frequency range shown "*" in the table above means the reading of emissions are attenuated more than 20dB below the permissible limits or the field strength is too small to be measured.
- (5) A preamp and high pass filter were used for this test in order to provide sufficient measurement sensitivity.
- (6) EUT Orthogonal Axis:
"X" - denotes Laid on Table ; "Y" - denotes Vertical Stand ; "Z" - denotes Side Stand
- (7) During the measurements above 1 GHz it is taken care of that the EUT is always within the 3 dB cone of radiation BW of the used antenna



TX CH78 (Above 1000 MHz, Vertical)

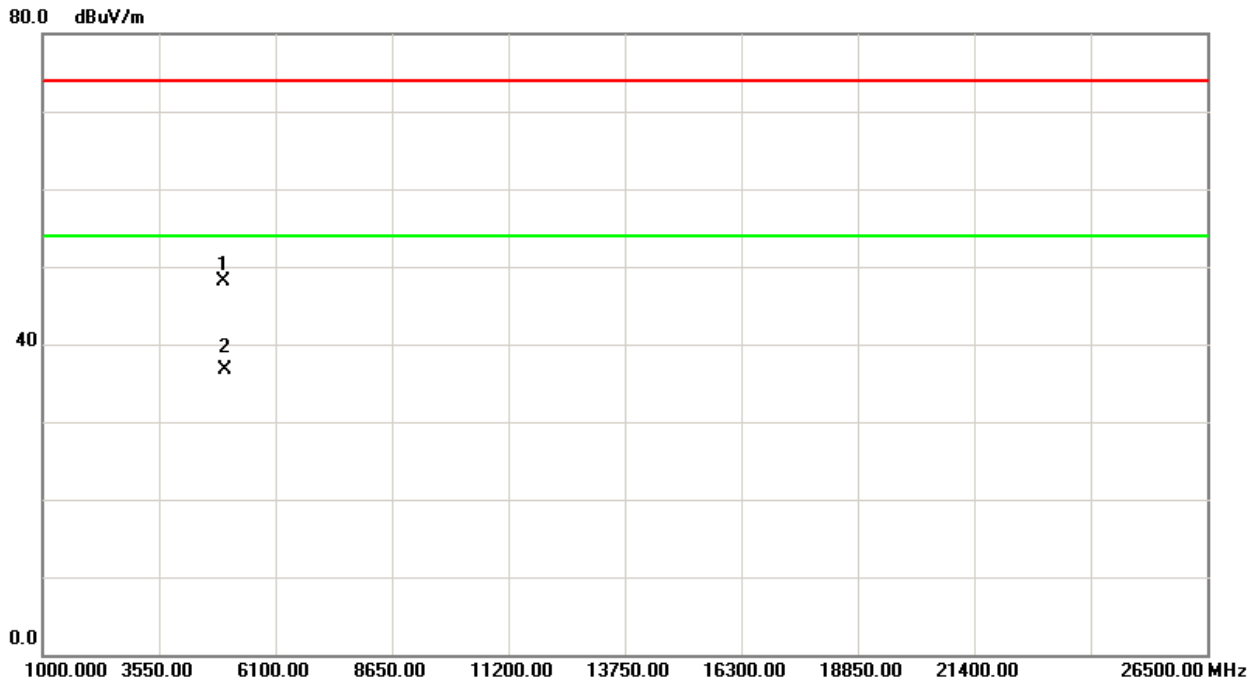
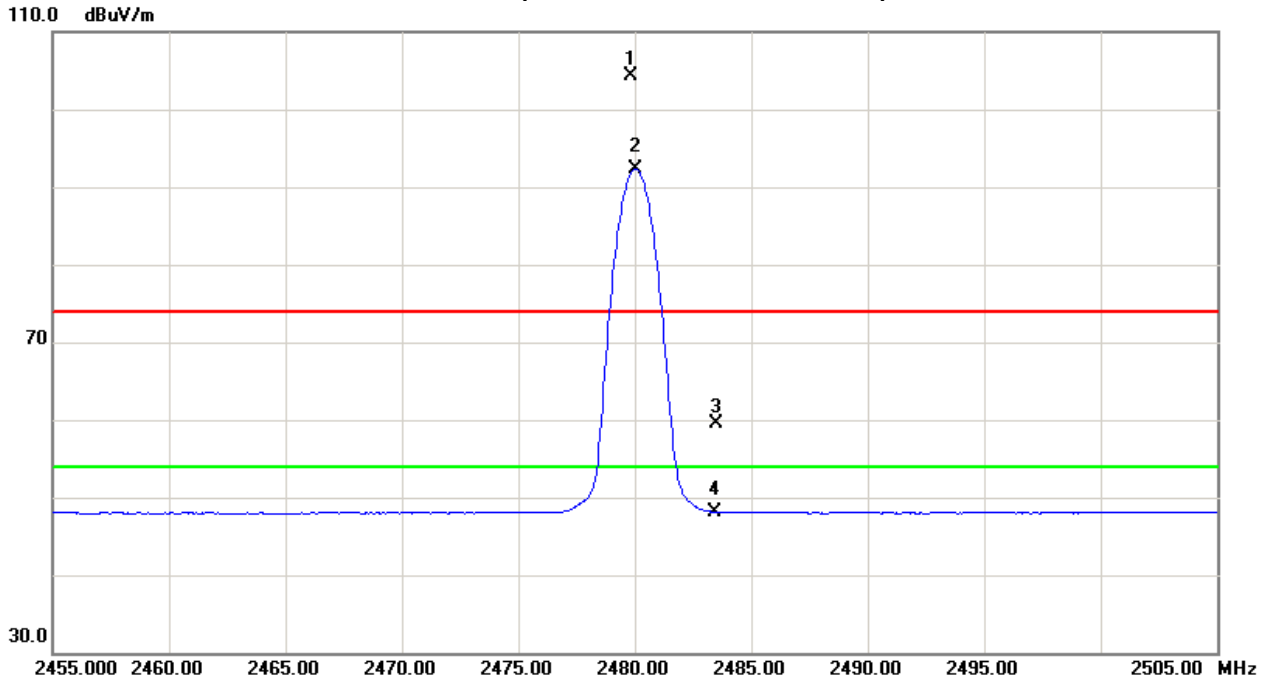



| | | | |
|--------------|-----------------------------|--------------------|---------|
| EUT: | Cisco TelePresence Touch 10 | Model Name: | TTC5-09 |
| Temperature: | 25 °C | Relative Humidity: | 58 % |
| Pressure: | 1010 hPa | Test Voltage: | DC 48V |
| Test Mode: | TX 2480MHz -CH78 -3Mbps | | |

| Freq. (MHz) | Ant.Pol. H/V | Reading | | Ant./CF CF(dB) | Act. | | Limit | | Note |
|----------------|-----------------|----------------|--------------|-------------------|------------------|----------------|------------------|----------------|------------|
| | | Peak (dBuV) | AV (dBuV) | | Peak (dBuV/m) | AV (dBuV/m) | Peak (dBuV/m) | AV (dBuV/m) | |
| 2480.00 | H | 71.05 | 58.97 | 34.36 | 105.41 | 93.33 | | | X/F |
| 2483.50 | H | 23.20 | 13.80 | 34.37 | 57.57 | 48.17 | 74.00 | 54.00 | X/E |
| 4960.02 | H | 40.25 | 29.30 | 6.83 | 47.08 | 36.13 | 74.00 | 54.00 | X/H |

Remark:

- (1) All readings are Peak unless otherwise stated QP in column of 『Note』 . Peak denotes that the Peak reading compliance with the QP Limits and then QP Mode measurement didn't perform.
- (2) Measuring frequency range from 30MHz to 1000MHz or the 10th harmonic of highest fundamental frequency. "F" denotes fundamental frequency;"H" denotes spurious frequency. "E" denotes band edge frequency. (This judgment method includes the Band Edge Requirement.)
- (3) Radiated emissions measured in frequency range above 1000MHz were made with an instrument using Peak detector mode and AV detector mode of the emission
- (4) Data of measurement within this frequency range shown "*" in the table above means the reading of emissions are attenuated more than 20dB below the permissible limits or the field strength is too small to be measured.
- (5) A preamp and high pass filter were used for this test in order to provide sufficient measurement sensitivity.
- (6) EUT Orthogonal Axis:
"X" - denotes Laid on Table ; "Y" - denotes Vertical Stand ; "Z" - denotes Side Stand
- (7) During the measurements above 1 GHz it is taken care of that the EUT is always within the 3 dB cone of radiation BW of the used antenna



TX CH78 (Above 1000 MHz, Horizontal)

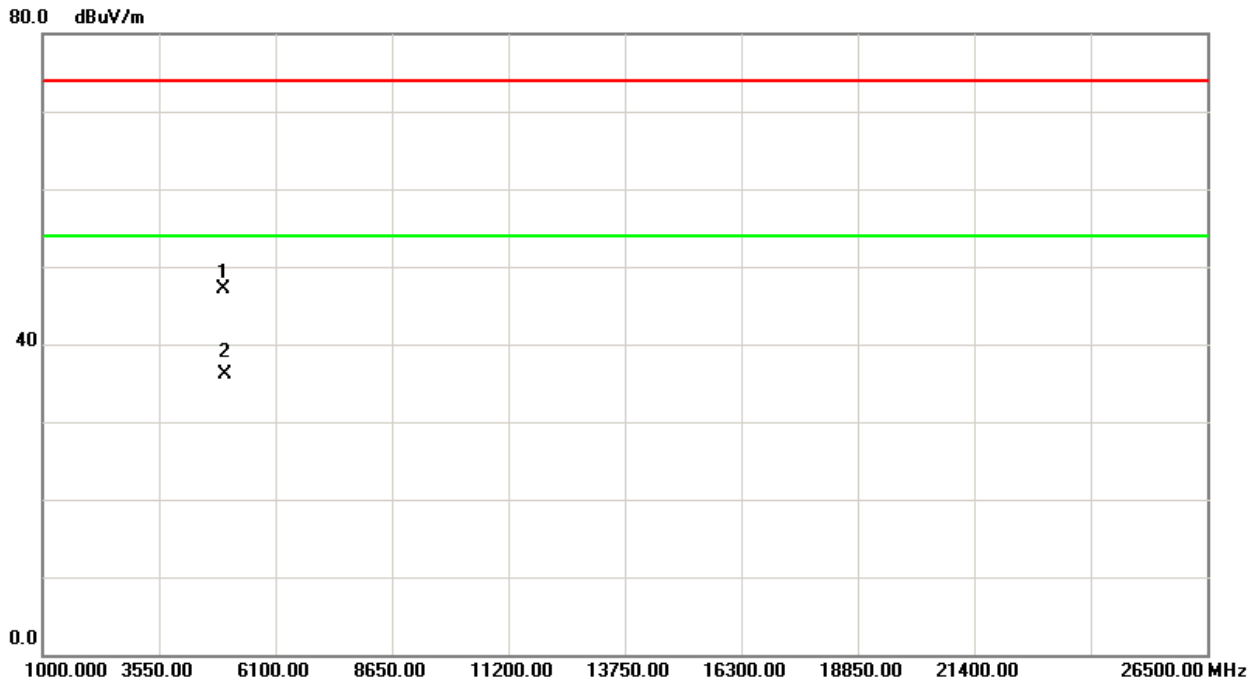
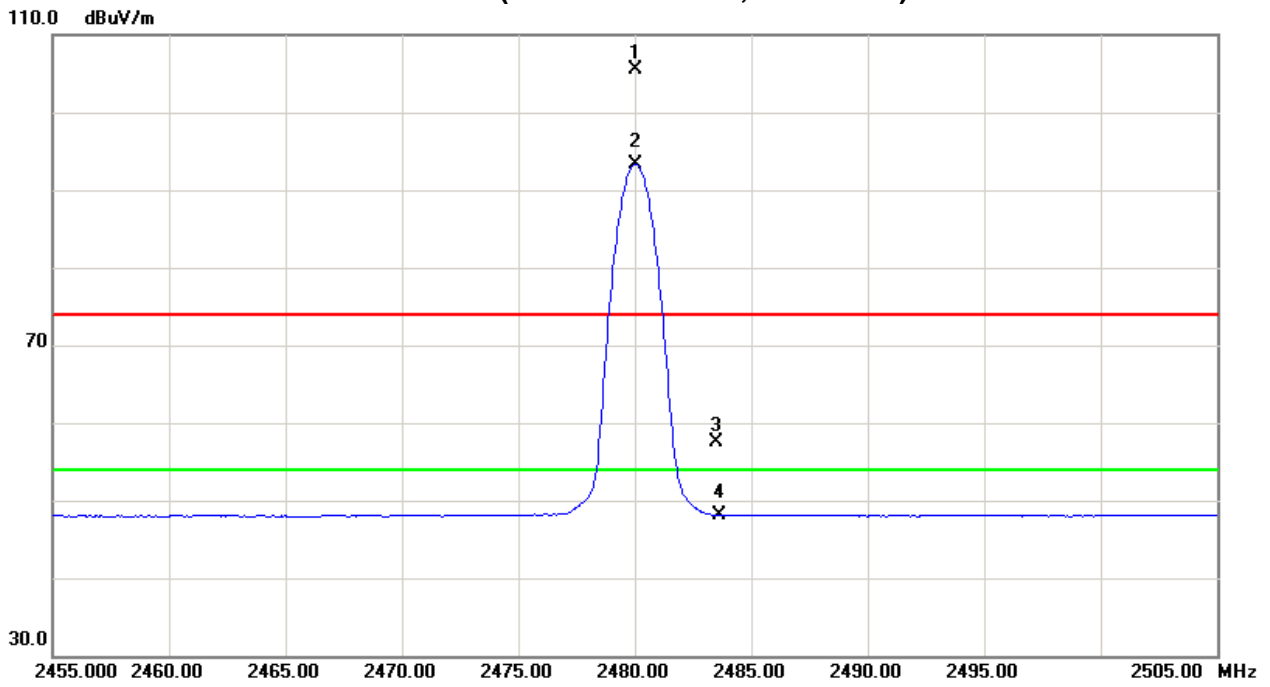



5. NUMBER OF HOPPING CHANNEL

5.1 APPLIED PROCEDURES

| FCC Part15 (15.247) , Subpart C/ RSS-GEN and RSS-210 | | | |
|---|---------------------------|-----------------------|--------|
| Section | Test Item | Frequency Range (MHz) | Result |
| 15.247(a)(1)(iii) RSS-210, Issue 8, Annex 8, A8.1(d) | Number of Hopping Channel | 2400-2483.5 | PASS |

5.1.1 MEASUREMENT INSTRUMENTS LIST AND SETTING

| Item | Kind of Equipment | Manufacturer | Type No. | Serial No. | Calibrated until |
|------|-------------------|--------------|----------|------------|------------------|
| 1 | Spectrum Analyzer | R&S | FSP 40 | 100185 | Nov. 16, 2013 |

Remark: "N/A" denotes no model name, serial no. or calibration specified.
All calibration period of equipment list is one year.

| Spectrum Parameters | Setting |
|---------------------|-----------------------------|
| Attenuation | Auto |
| Span Frequency | > Operating Frequency Range |
| RBW | 100 KHz |
| VBW | 100 KHz |
| Detector | Peak |
| Trace | Max Hold |
| Sweep Time | Auto |

5.1.2 TEST PROCEDURE

- a. The EUT was directly connected to the spectrum analyzer and antenna output port as show in the block diagram below,
- b. Spectrum Setting: RBW=100KHz, VBW=100KHz, Sweep time = Auto.

5.1.3 DEVIATION FROM STANDARD

No deviation.

5.1.4 TEST SETUP



5.1.5 EUT OPERATION CONDITIONS

The EUT tested system was configured as the statements of 4.1.6 Unless otherwise a special operating condition is specified in the follows during the testing.



5.1.6 TEST RESULTS

| | | | |
|--------------|-----------------------------|--------------------|---------|
| EUT: | Cisco TelePresence Touch 10 | Model Name: | TTC5-09 |
| Temperature: | 25 °C | Relative Humidity: | 58 % |
| Pressure: | 1009 hPa | Test Voltage: | DC 48V |
| Test Mode: | Hopping Mode -1Mbps | | |

| | |
|---------------------------|----|
| Number of Hopping Channel | 79 |
|---------------------------|----|

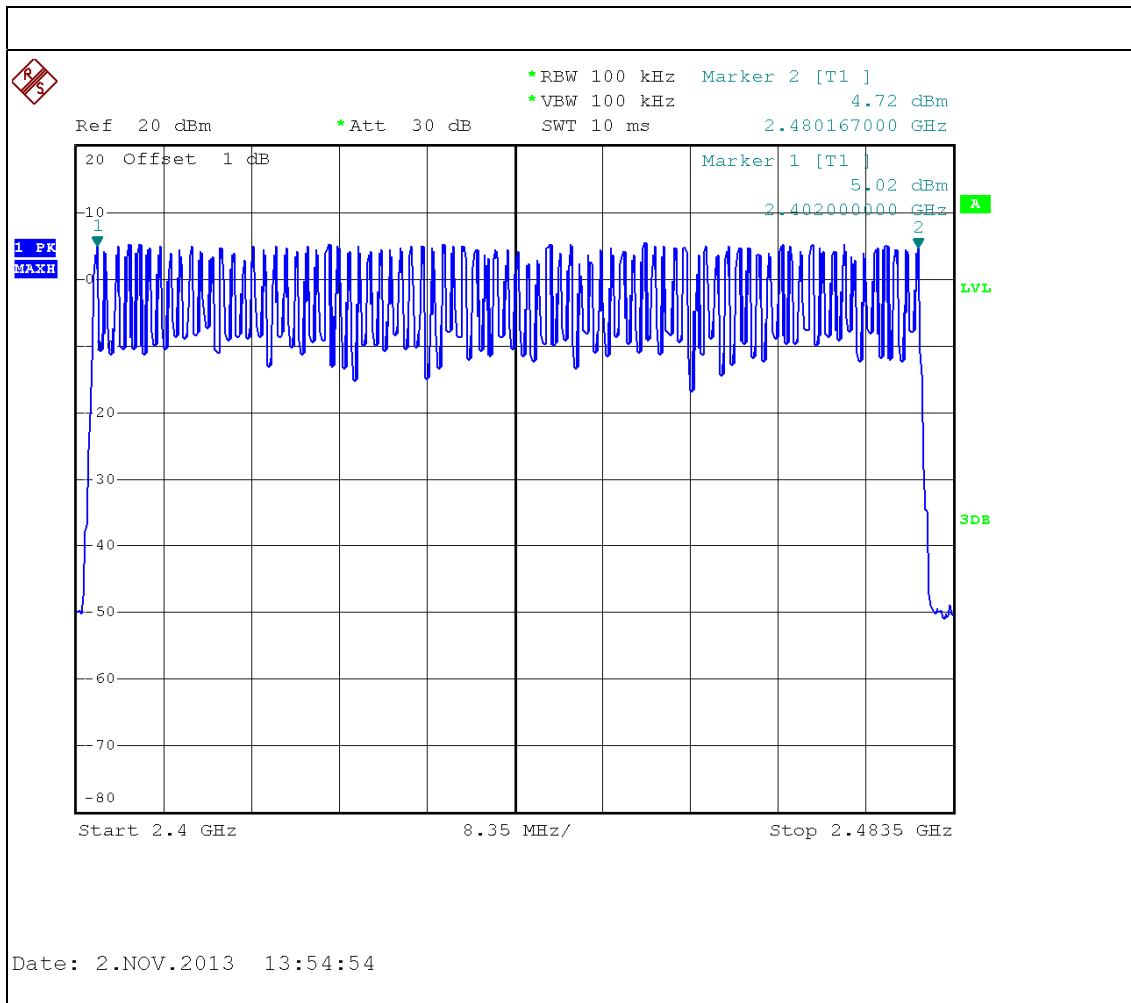



| | | | |
|--------------|-----------------------------|--------------------|---------|
| EUT: | Cisco TelePresence Touch 10 | Model Name: | TTC5-09 |
| Temperature: | 25 °C | Relative Humidity: | 58 % |
| Pressure: | 1009 hPa | Test Voltage: | DC 48V |
| Test Mode: | Hopping Mode -3Mbps | | |

| | |
|---------------------------|----|
| Number of Hopping Channel | 79 |
|---------------------------|----|

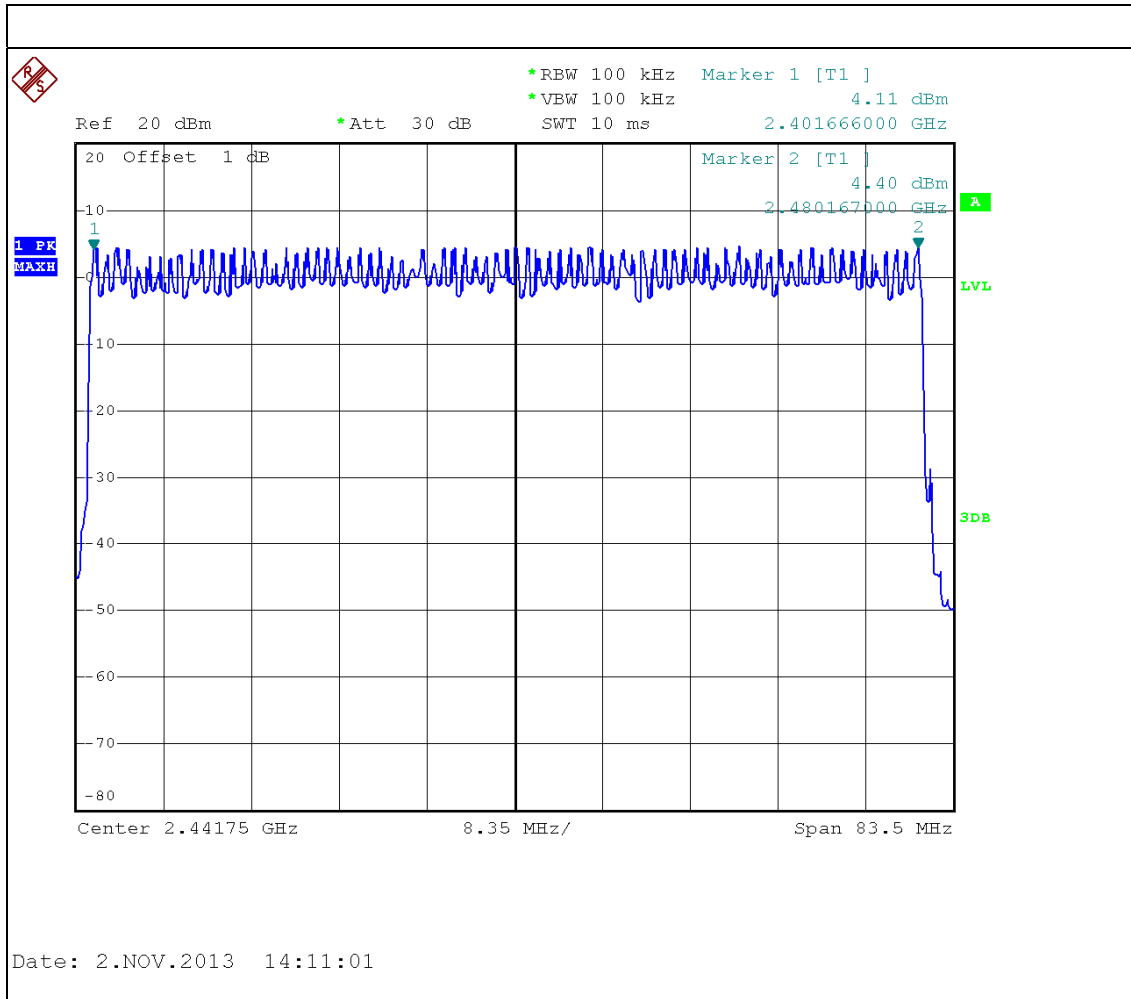



6. AVERAGE TIME OF OCCUPANCY

6.1 APPLIED PROCEDURES / LIMIT

| FCC Part15 (15.247) , Subpart C/ RSS-GEN and RSS-210 | | | | |
|---|---------------------------|--------|-----------------------|--------|
| Section | Test Item | Limit | Frequency Range (MHz) | Result |
| 15.247(a)(1)(iii) RSS-210, Issue 8, Annex 8, A8.1(d) | Average Time of Occupancy | 0.4sec | 2400-2483.5 | PASS |

6.1.1 MEASUREMENT INSTRUMENTS LIST

| Item | Kind of Equipment | Manufacturer | Type No. | Serial No. | Calibrated until |
|------|-------------------|--------------|----------|------------|------------------|
| 1 | Spectrum Analyzer | R&S | FSP 40 | 100185 | Nov. 16, 2013 |

Remark: "N/A" denotes no model name, serial no. or calibration specified.
All calibration period of equipment list is one year.

6.1.2 TEST PROCEDURE

- a. The transmitter output (antenna port) was connected to the spectrum analyzer
- b. Set RBW of spectrum analyzer to 1MHz and VBW to 1MHz.
- c. Use a video trigger with the trigger level set to enable triggering only on full pulses.
- d. Sweep Time is more than once pulse time.
- e. Set the center frequency on any frequency would be measure and set the frequency span to zero span.
- f. Measure the maximum time duration of one single pulse.
- g. Set the EUT for DH5, DH3 and DH1 packet transmitting.
- h. Measure the maximum time duration of one single pulse.
- i. DH5 Packet permit maximum $1600 / 79 / 6 = 3.37$ hops per second in each channel (5 time slots TX, 1 time slot RX). So, the dwell time is the time duration of the pulse times $3.37 \times 31.6 = 106.6$ within 31.6 seconds.
- j. DH3 Packet permit maximum $1600 / 79 / 4 = 5.06$ hops per second in each channel (3 time slots TX, 1 time slot RX). So, the dwell time is the time duration of the pulse times $5.06 \times 31.6 = 160$ within 31.6 seconds.
- k. DH1 Packet permit maximum $1600 / 79 / 2 = 10.12$ hops per second in each channel (1 time slot TX, 1 time slot RX). So, the dwell time is the time duration of the pulse times $10.12 \times 31.6 = 320$ within 31.6 seconds.

6.1.3 DEVIATION FROM STANDARD

No deviation.



6.1.4 TEST SETUP

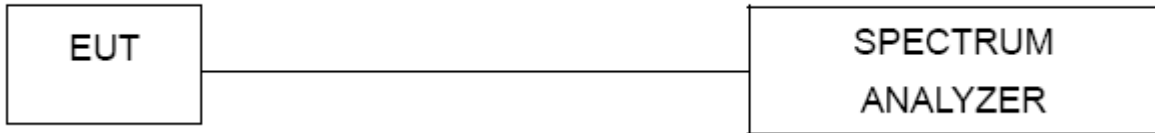

6.1.5 EUT OPERATION CONDITIONS

The EUT tested system was configured as the statements of 4.1.6 Unless otherwise a special operating condition is specified in the follows during the testing.



6.1.6 TEST RESULTS

| | | | |
|--------------|-----------------------------|--------------------|---------|
| EUT: | Cisco TelePresence Touch 10 | Model Name: | TTC5-09 |
| Temperature: | 25 °C | Relative Humidity: | 58 % |
| Pressure: | 1009 hPa | Test Voltage: | DC 48V |
| Test Mode: | CH00-DH1/DH3/DH5 -1Mbps | | |

| Data Packet | Frequency (MHz) | Pulse Duration (ms) | Dwell Time (s) | Limit (s) |
|-------------|-----------------|---------------------|----------------|-----------|
| DH5 | 2402 | 3.0000 | 0.3200 | 0.4000 |
| DH3 | 2402 | 1.7000 | 0.2720 | 0.4000 |
| DH1 | 2402 | 0.4050 | 0.1296 | 0.4000 |

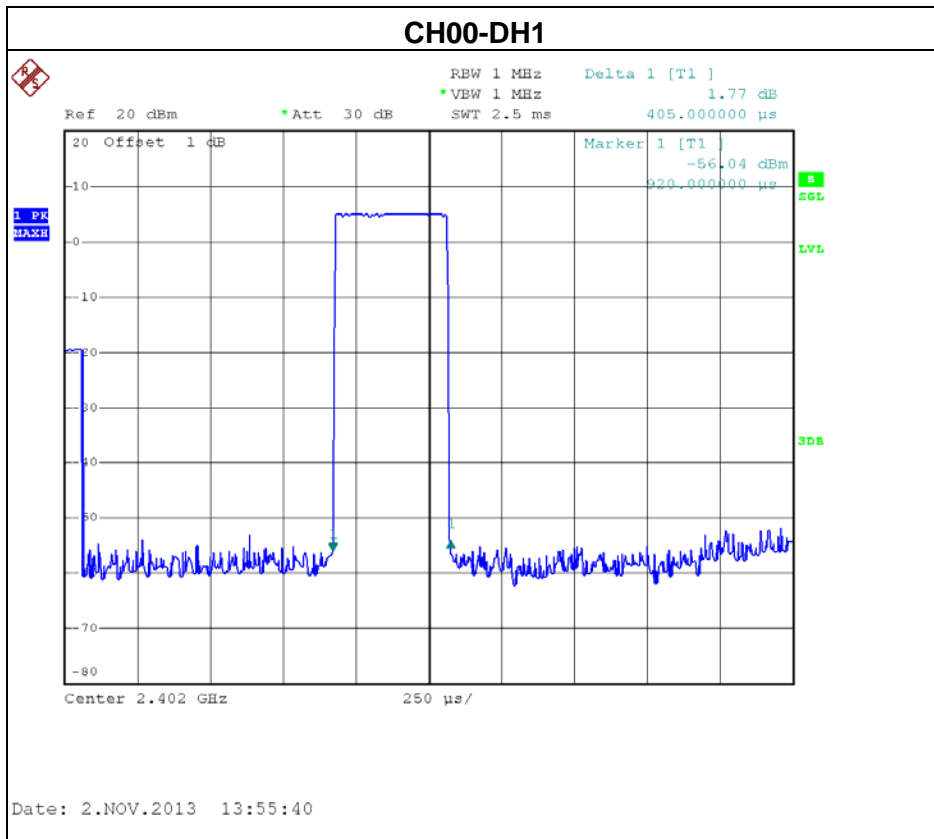

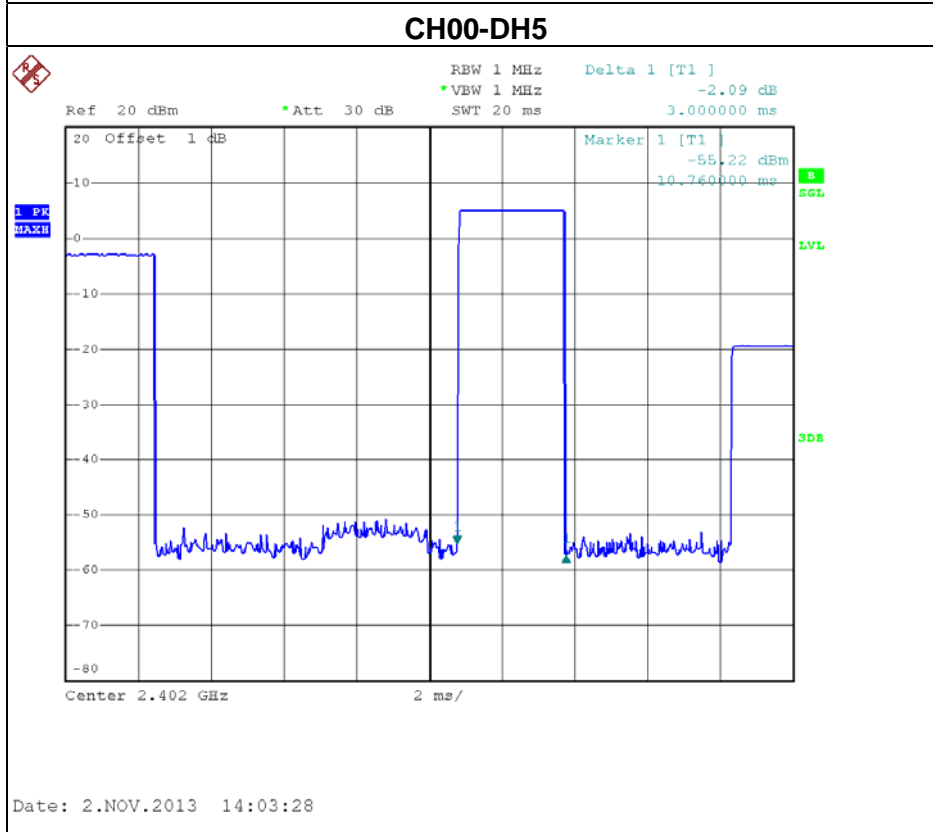
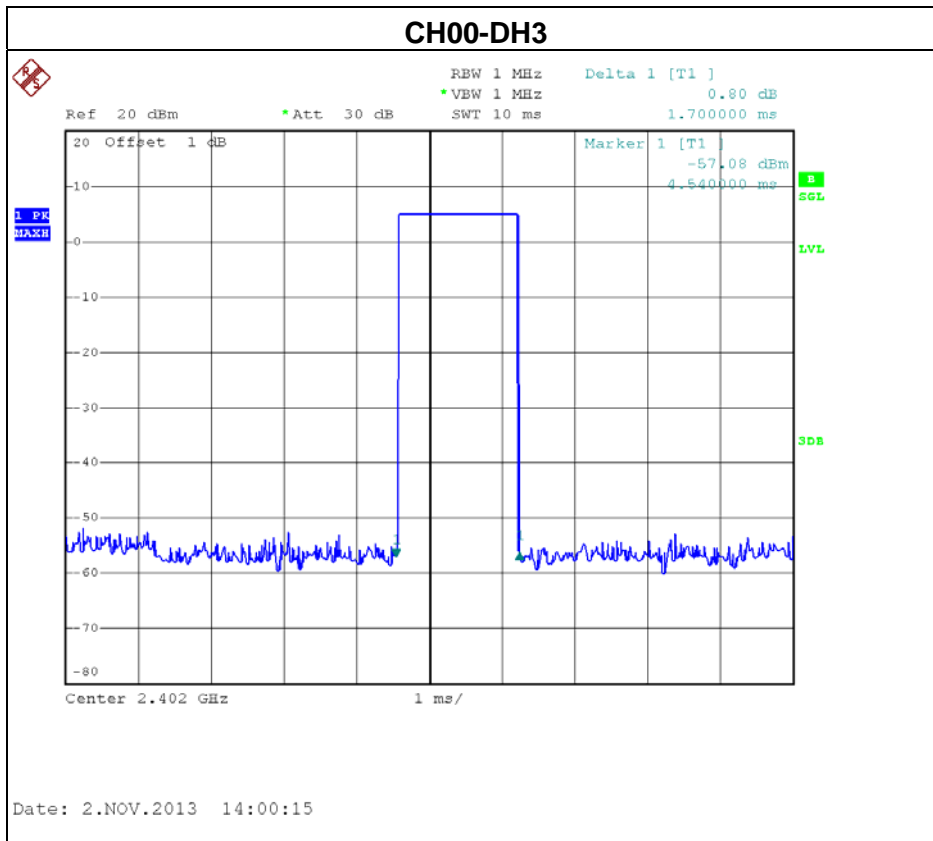



| | | | |
|--------------|-----------------------------|--------------------|---------|
| EUT: | Cisco TelePresence Touch 10 | Model Name: | TTC5-09 |
| Temperature: | 25 °C | Relative Humidity: | 58 % |
| Pressure: | 1009 hPa | Test Voltage: | DC 48V |
| Test Mode: | CH39 -DH1/DH3/DH5 -1Mbps | | |

| Data Packet | Frequency (MHz) | Pulse Duration (ms) | Dwell Time (s) | Limit (s) |
|-------------|-----------------|---------------------|----------------|-----------|
| DH5 | 2441 | 2.9600 | 0.3157 | 0.4000 |
| DH3 | 2441 | 1.7400 | 0.2784 | 0.4000 |
| DH1 | 2441 | 0.4150 | 0.1328 | 0.4000 |

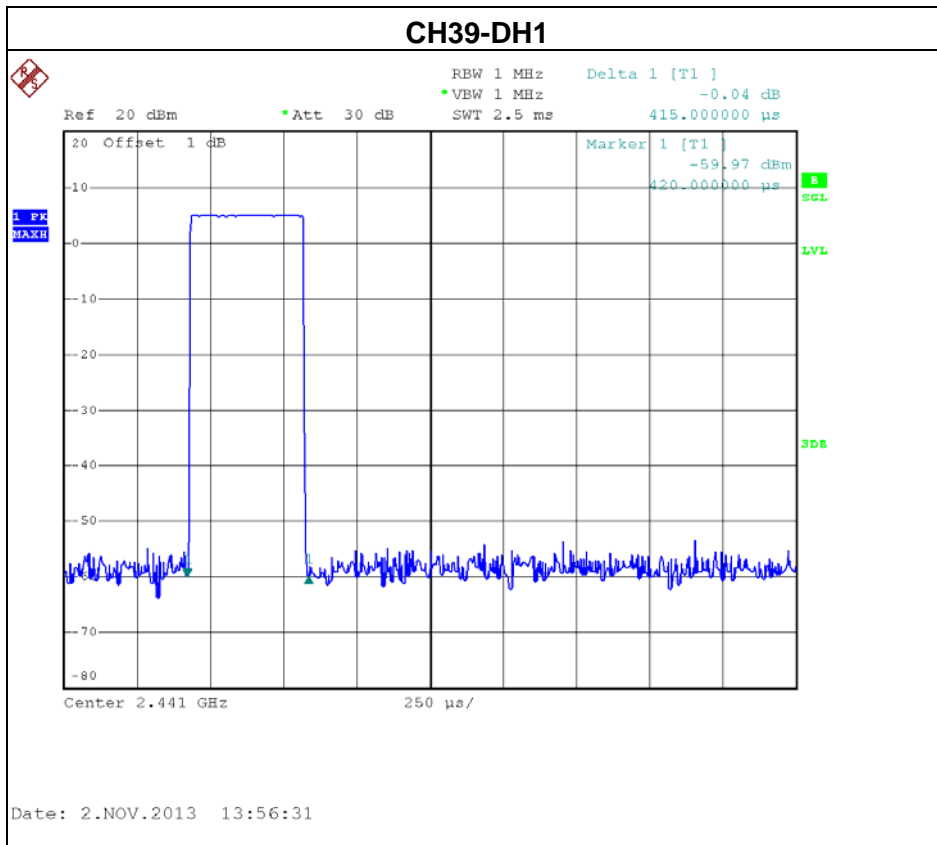

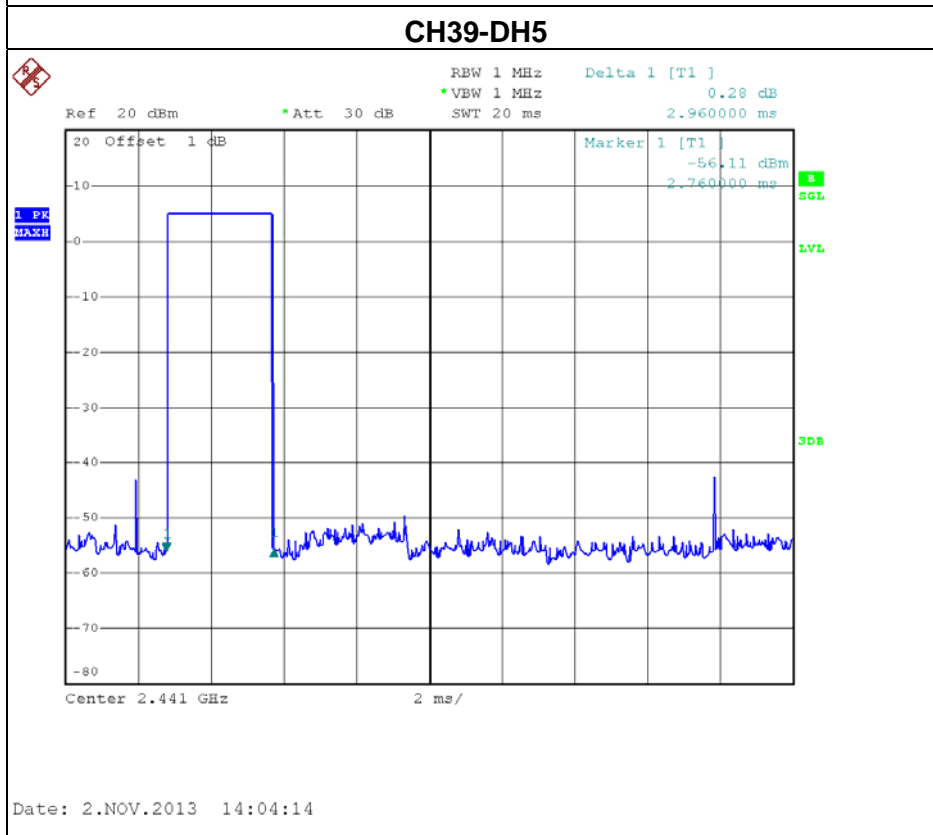
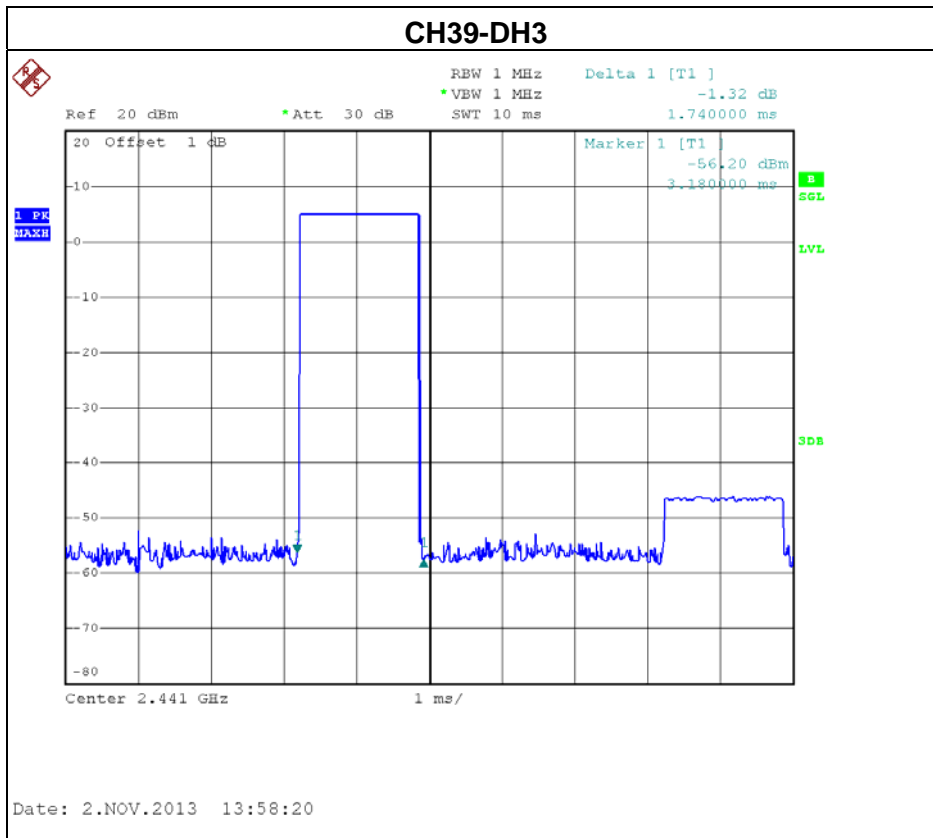



| | | | |
|--------------|-----------------------------|--------------------|---------|
| EUT: | Cisco TelePresence Touch 10 | Model Name: | TTC5-09 |
| Temperature: | 25 °C | Relative Humidity: | 58 % |
| Pressure: | 1009 hPa | Test Voltage: | DC 48V |
| Test Mode: | CH78 -DH1/DH3/DH5-1Mbps | | |

| Data Packet | Frequency (MHz) | Pulse Duration (ms) | Dwell Time (s) | Limit (s) |
|-------------|-----------------|---------------------|----------------|-----------|
| DH5 | 2480 | 3.0000 | 0.3200 | 0.4000 |
| DH3 | 2480 | 1.7400 | 0.2784 | 0.4000 |
| DH1 | 2480 | 0.4000 | 0.1280 | 0.4000 |

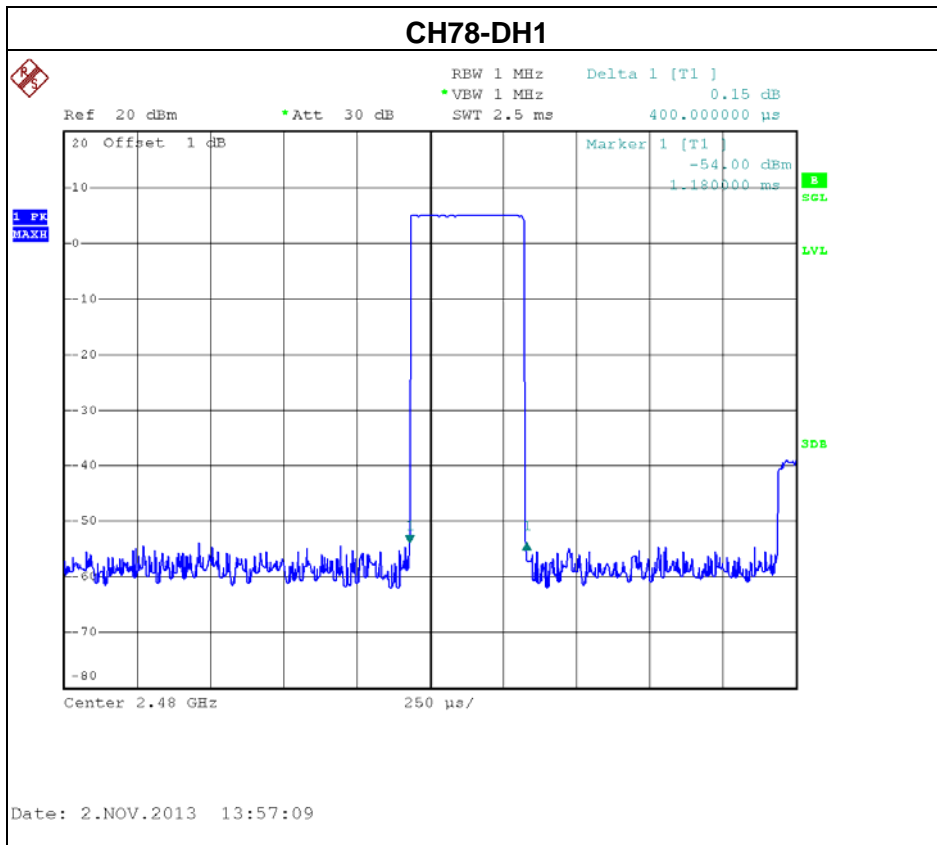

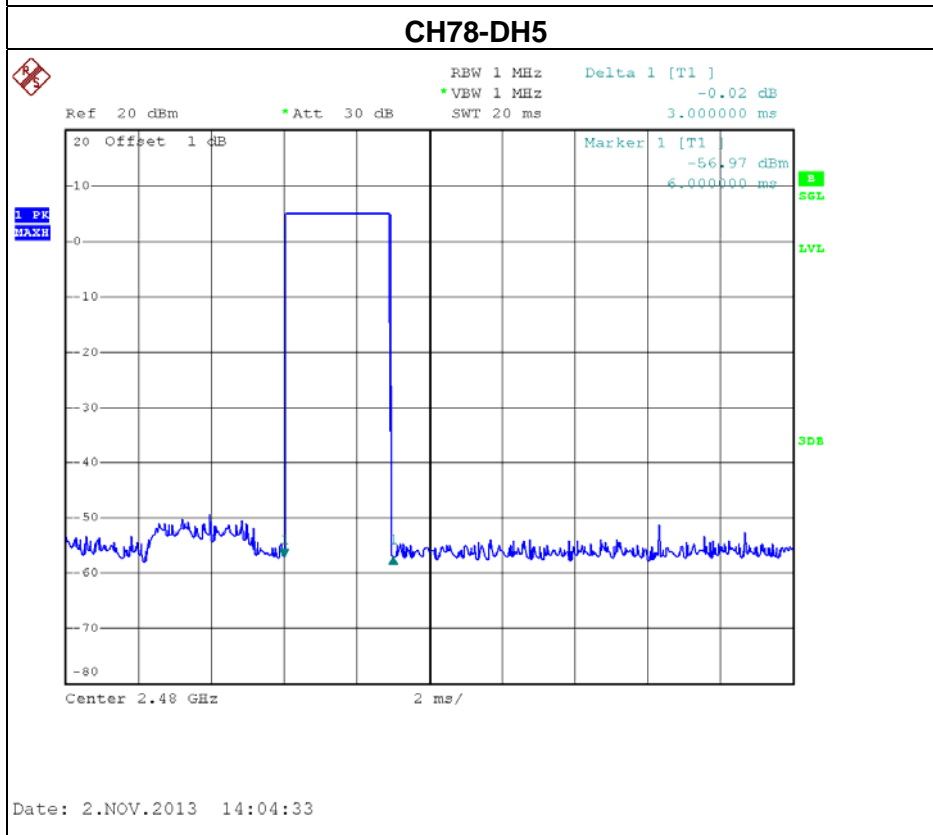
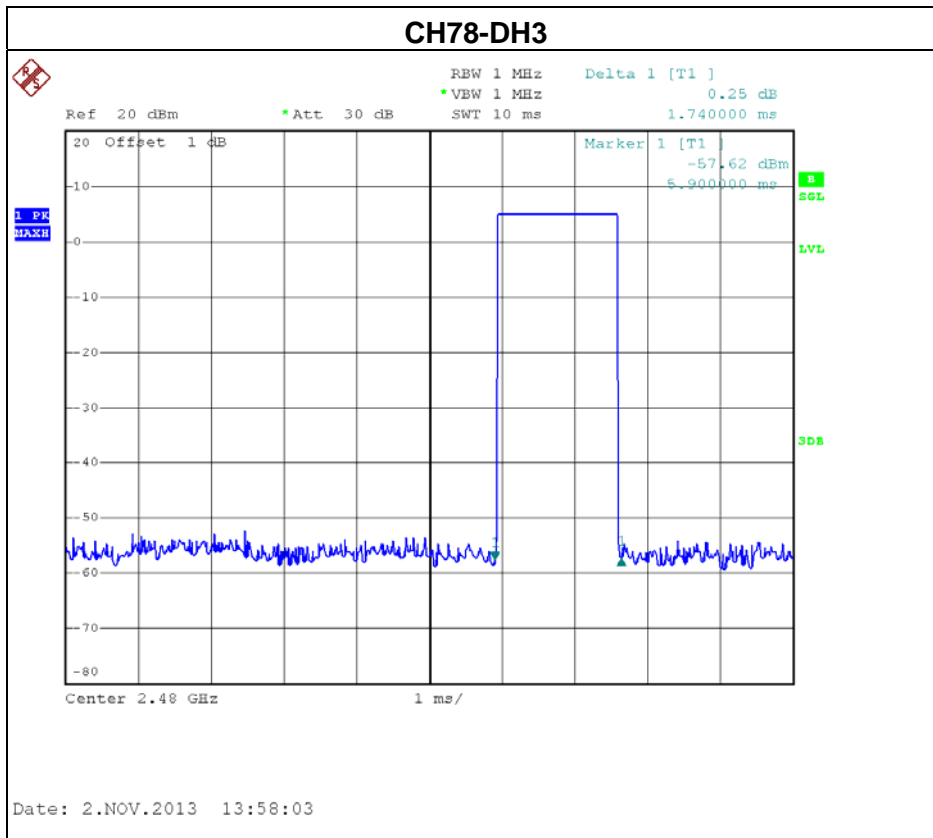



| | | | |
|--------------|-----------------------------|--------------------|---------|
| EUT: | Cisco TelePresence Touch 10 | Model Name: | TTC5-09 |
| Temperature: | 25 °C | Relative Humidity: | 58 % |
| Pressure: | 1009 hPa | Test Voltage: | DC 48V |
| Test Mode: | CH00-DH1/DH3/DH5-3Mbps | | |

| Data Packet | Frequency (MHz) | Pulse Duration (ms) | Dwell Time (s) | Limit (s) |
|-------------|-----------------|---------------------|----------------|-----------|
| DH5 | 2402 | 3.0400 | 0.3243 | 0.4000 |
| DH3 | 2402 | 1.7400 | 0.2784 | 0.4000 |
| DH1 | 2402 | 0.4400 | 0.1408 | 0.4000 |

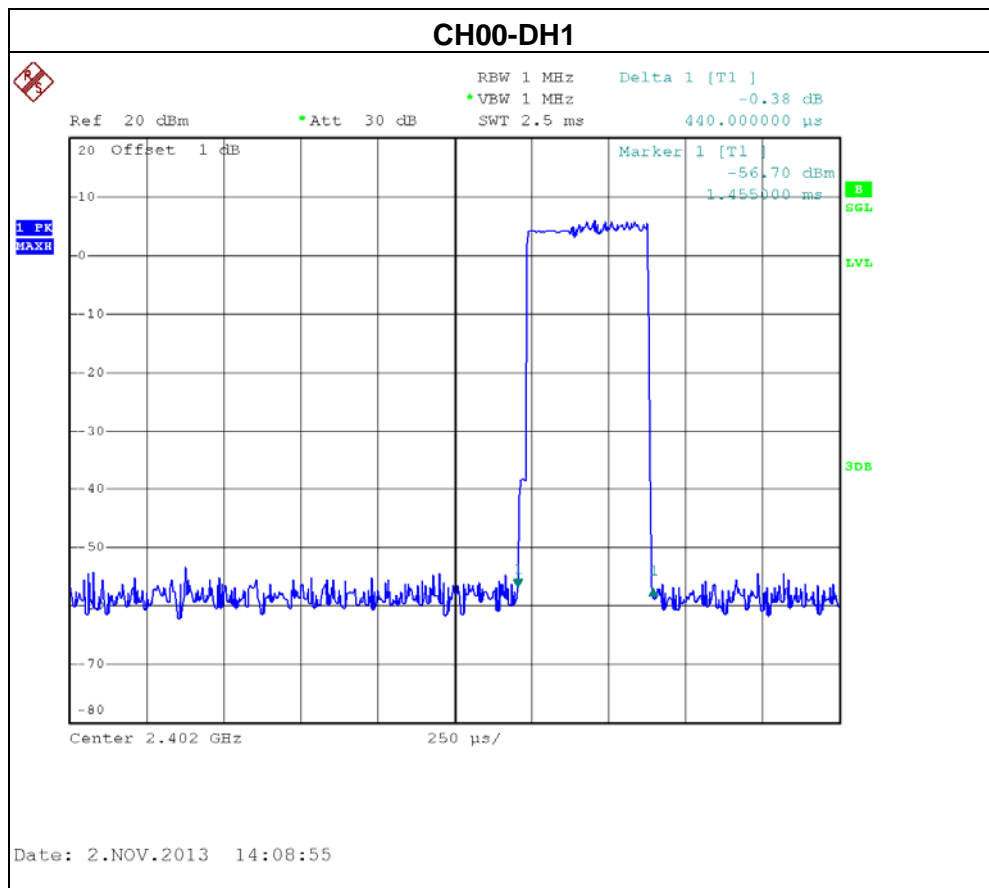

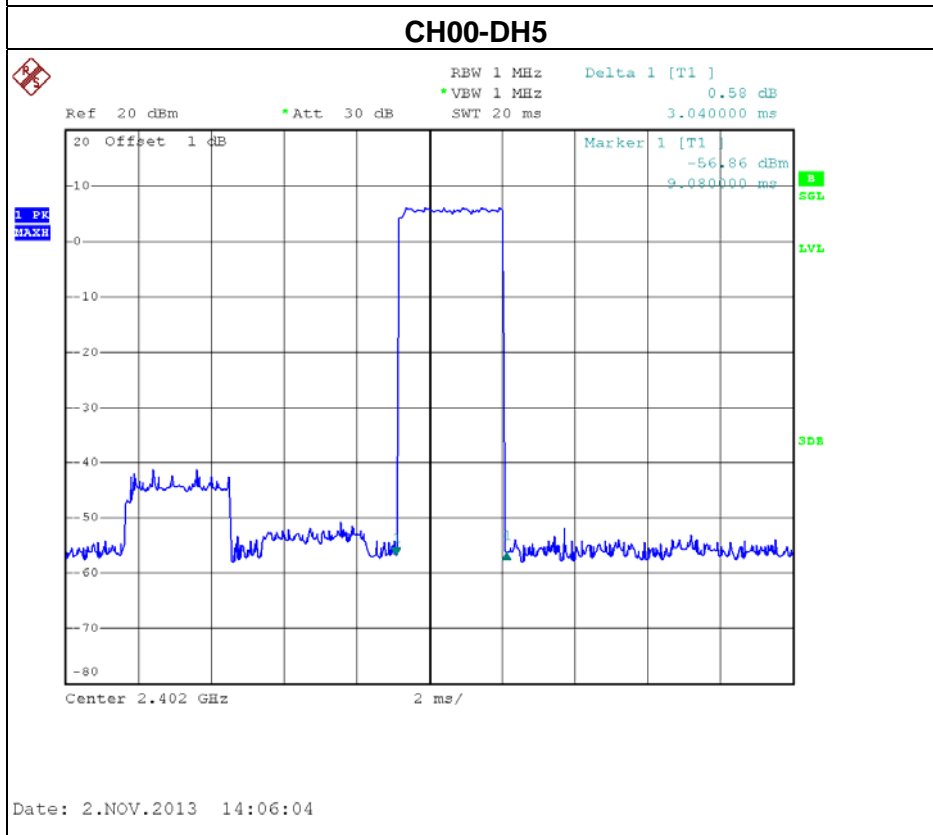
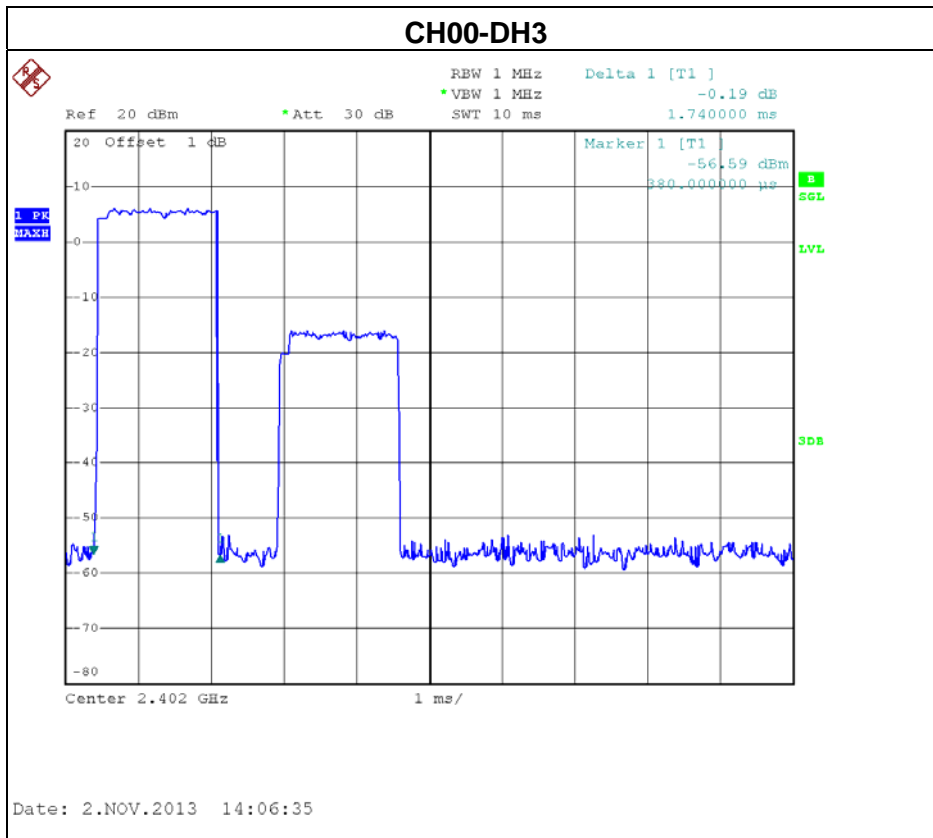



| | | | |
|--------------|-----------------------------|--------------------|---------|
| EUT: | Cisco TelePresence Touch 10 | Model Name: | TTC5-09 |
| Temperature: | 25 °C | Relative Humidity: | 58 % |
| Pressure: | 1009 hPa | Test Voltage: | DC 48V |
| Test Mode: | CH39 -DH1/DH3/DH5-3Mbps | | |

| Data Packet | Frequency (MHz) | Pulse Duration (ms) | Dwell Time (s) | Limit (s) |
|-------------|-----------------|---------------------|----------------|-----------|
| DH5 | 2441 | 3.0000 | 0.3200 | 0.4000 |
| DH3 | 2441 | 1.7200 | 0.2752 | 0.4000 |
| DH1 | 2441 | 0.4400 | 0.1408 | 0.4000 |

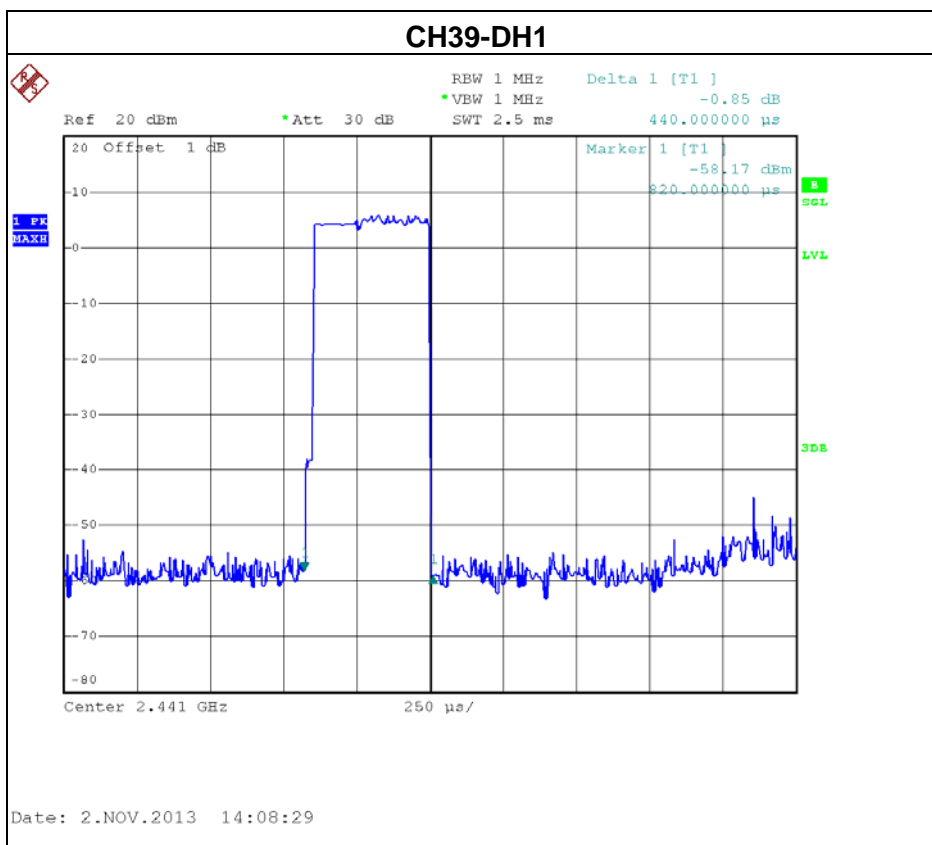

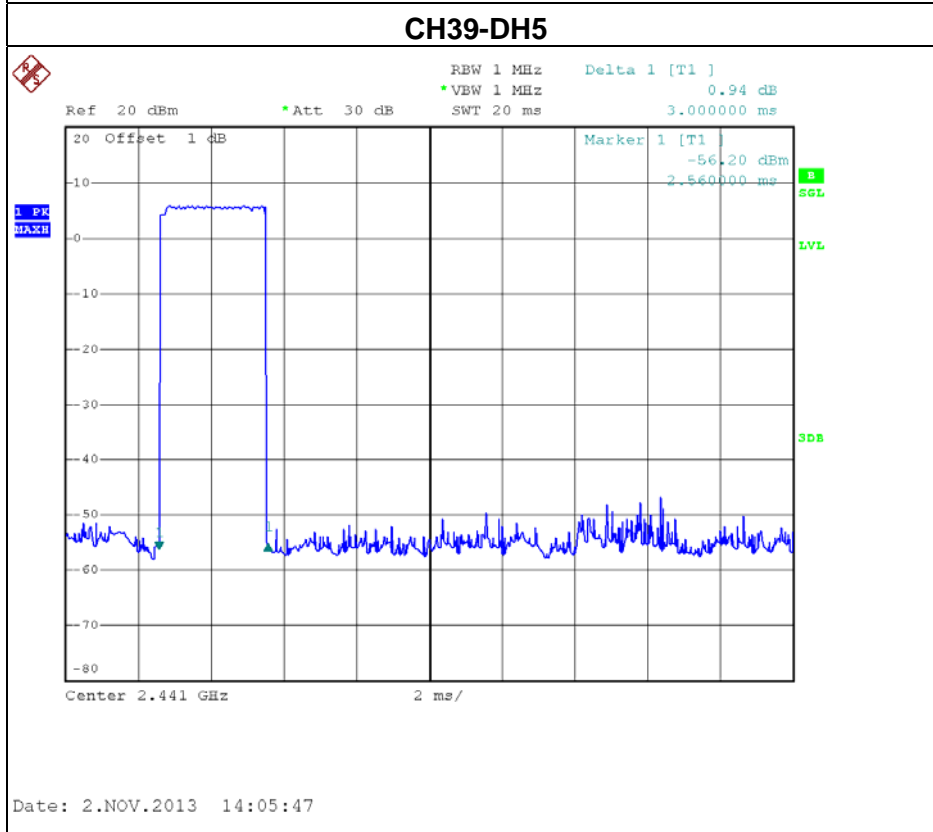
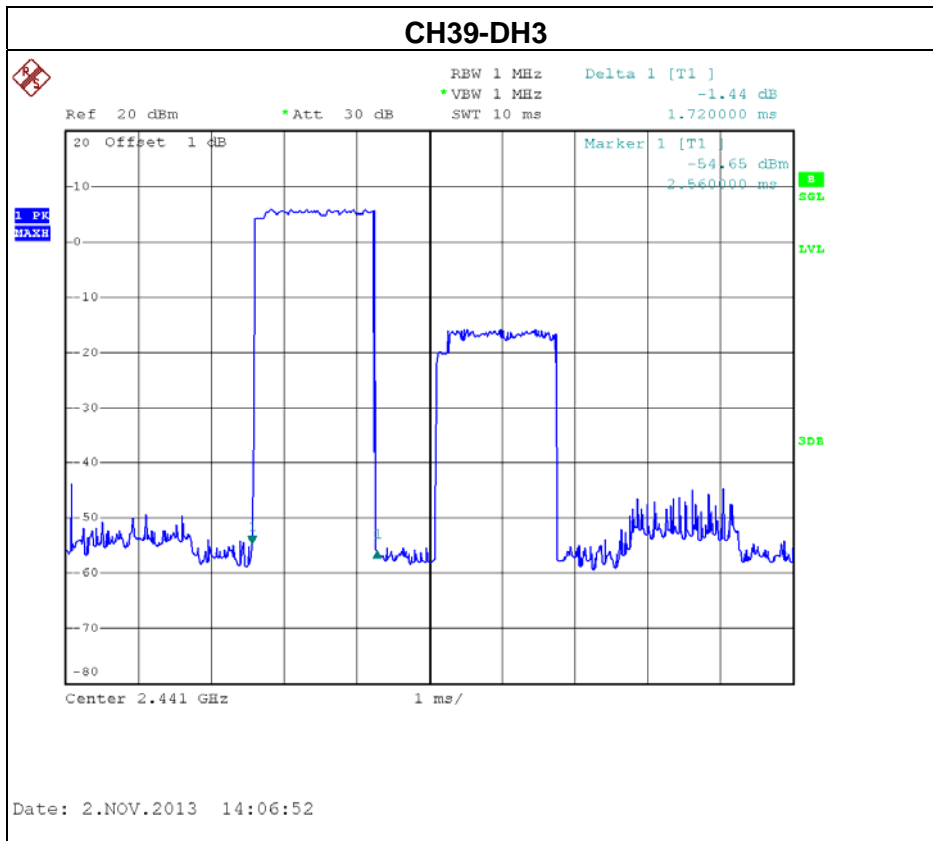



| | | | |
|--------------|-----------------------------|--------------------|---------|
| EUT: | Cisco TelePresence Touch 10 | Model Name: | TTC5-09 |
| Temperature: | 25 °C | Relative Humidity: | 58 % |
| Pressure: | 1009 hPa | Test Voltage: | DC 48V |
| Test Mode: | CH78 -DH1/DH3/DH5-3Mbps | | |

| Data Packet | Frequency (MHz) | Pulse Duration (ms) | Dwell Time (s) | Limit (s) |
|-------------|-----------------|---------------------|----------------|-----------|
| DH5 | 2480 | 3.0400 | 0.3243 | 0.4000 |
| DH3 | 2480 | 1.7200 | 0.2752 | 0.4000 |
| DH1 | 2480 | 0.4400 | 0.1408 | 0.4000 |

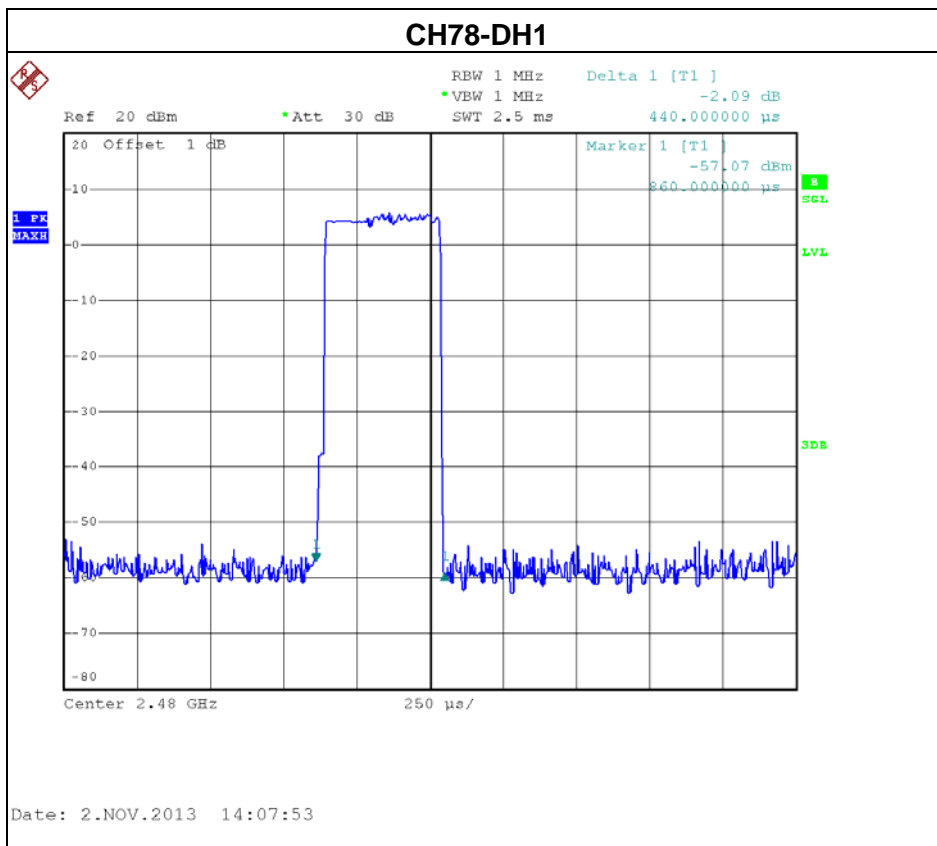

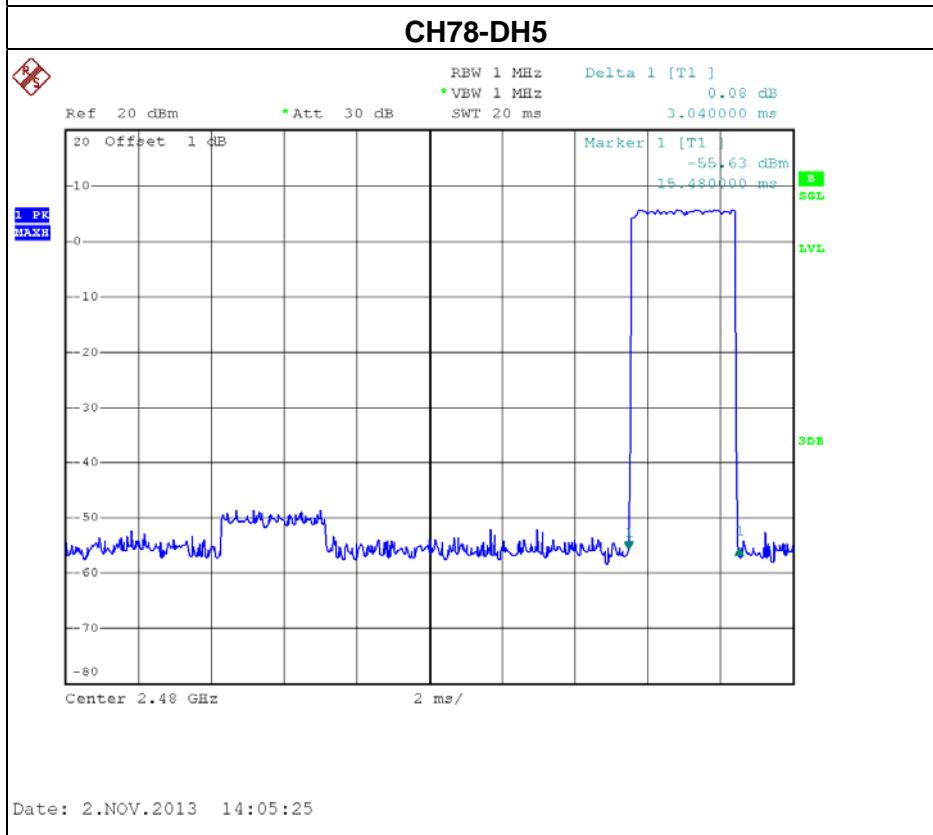
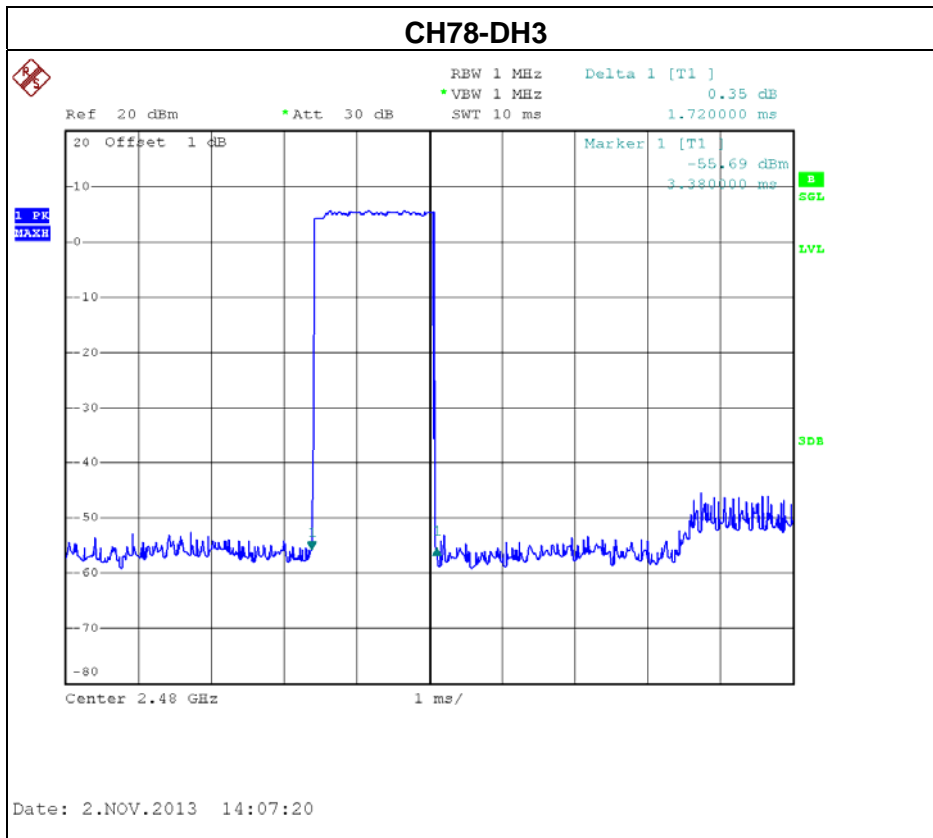

7. HOPPING CHANNEL SEPARATION MEASUREMENT

7.1 APPLIED PROCEDURES / LIMIT

Frequency hopping systems operating in the 2400-2483.5 MHz band may have hopping channel carrier frequencies that are separated by 25 KHz or two-thirds of the 20 dB bandwidth of the hopping channel, whichever is greater.

7.1.1 MEASUREMENT INSTRUMENTS LIST AND SETTING

| Item | Kind of Equipment | Manufacturer | Type No. | Serial No. | Calibrated until |
|------|-------------------|--------------|----------|------------|------------------|
| 1 | Spectrum Analyzer | R&S | FSP 40 | 100185 | Nov. 16, 2013 |

Remark: "N/A" denotes no model name, serial no. or calibration specified.

All calibration period of equipment list is one year.

| Spectrum Parameter | Setting |
|--------------------|---|
| Attenuation | Auto |
| Span Frequency | > Measurement Bandwidth or Channel Separation |
| RBW | 30 KHz |
| VBW | 100 KHz |
| Detector | Peak |
| Trace | Max Hold |
| Sweep Time | Auto |

7.1.2 TEST PROCEDURE

- a. The EUT must have its hopping function enabled
- b. Span = wide enough to capture the peaks of two adjacent channels
 - Resolution (or IF) Bandwidth (RBW) \geq 1% of the span
 - Video (or Average) Bandwidth (VBW) \geq RBW
 - Sweep = Auto
 - Detector function = Peak
 - Trace = Max Hold

7.1.3 DEVIATION FROM STANDARD

No deviation.

7.1.4 TEST SETUP

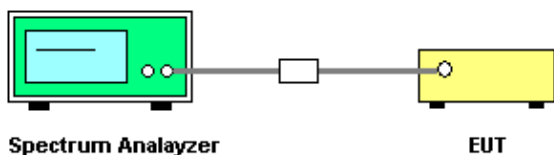

7.1.5 EUT OPERATION CONDITIONS

The EUT was programmed to be in hopping mode.



7.1.6 TEST RESULTS

| | | | |
|--------------|-------------------------------------|--------------------|---------|
| EUT: | Cisco TelePresence Touch 10 | Model Name: | TTC5-09 |
| Temperature: | 25 °C | Relative Humidity: | 58 % |
| Pressure: | 1009 hPa | Test Voltage: | DC 48V |
| Test Mode: | Hopping on -CH00 / CH39 /CH78-1Mbps | | |

| Frequency (MHz) | Ch. Separation (MHz) | 2/3 of the 20 dB bandwidth (MHz) | Result |
|-----------------|----------------------|----------------------------------|-----------------|
| 2402 | 0.996 | 0.627 | Complies |
| 2441 | 1.008 | 0.633 | Complies |
| 2480 | 1.008 | 0.627 | Complies |

Ch. Separation Limit: >20dB bandwidth or >2/3 of the 20 dB bandwidth

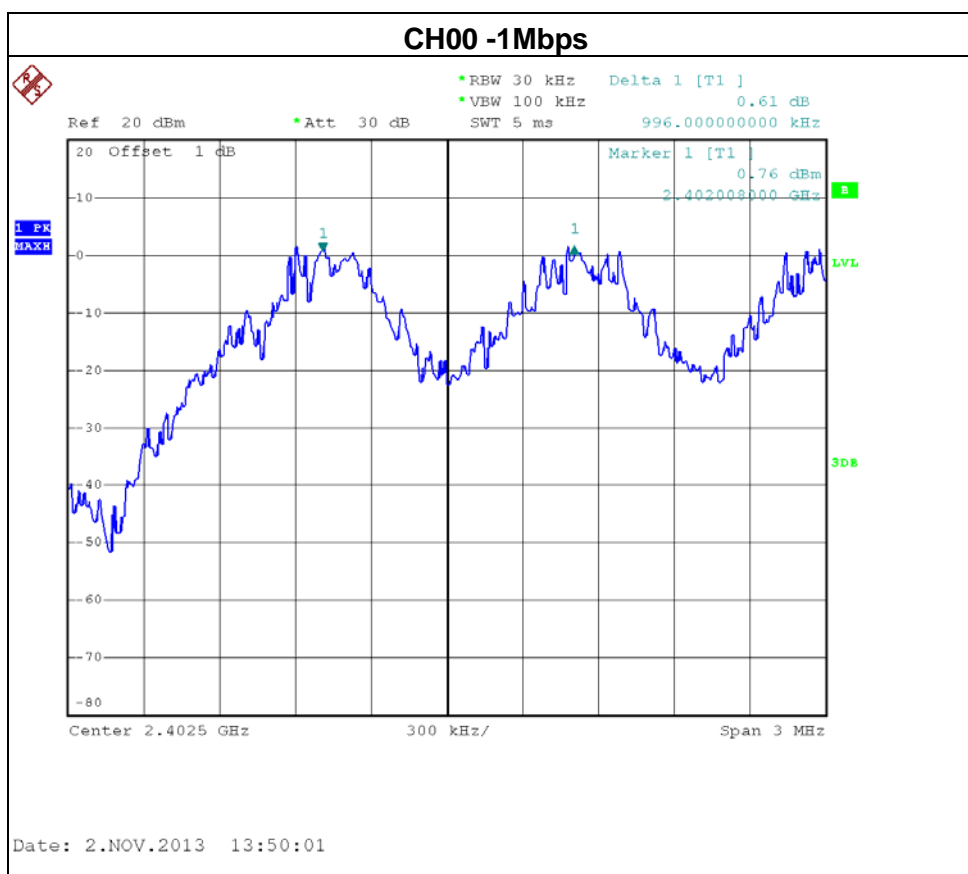

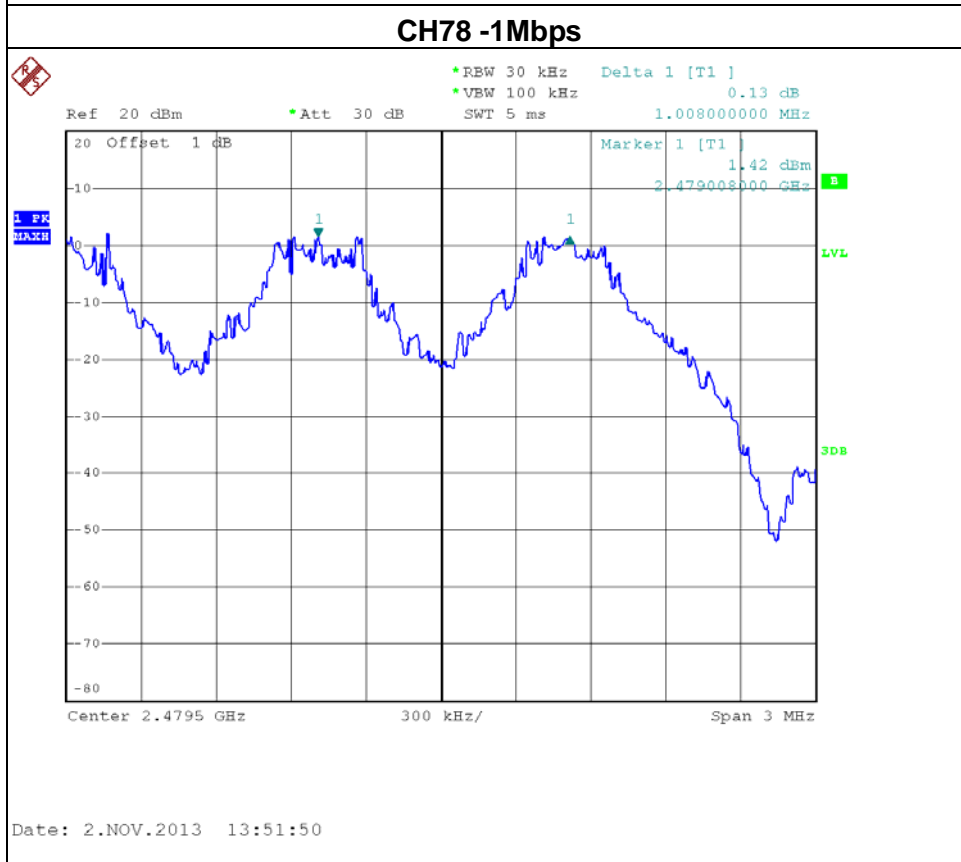
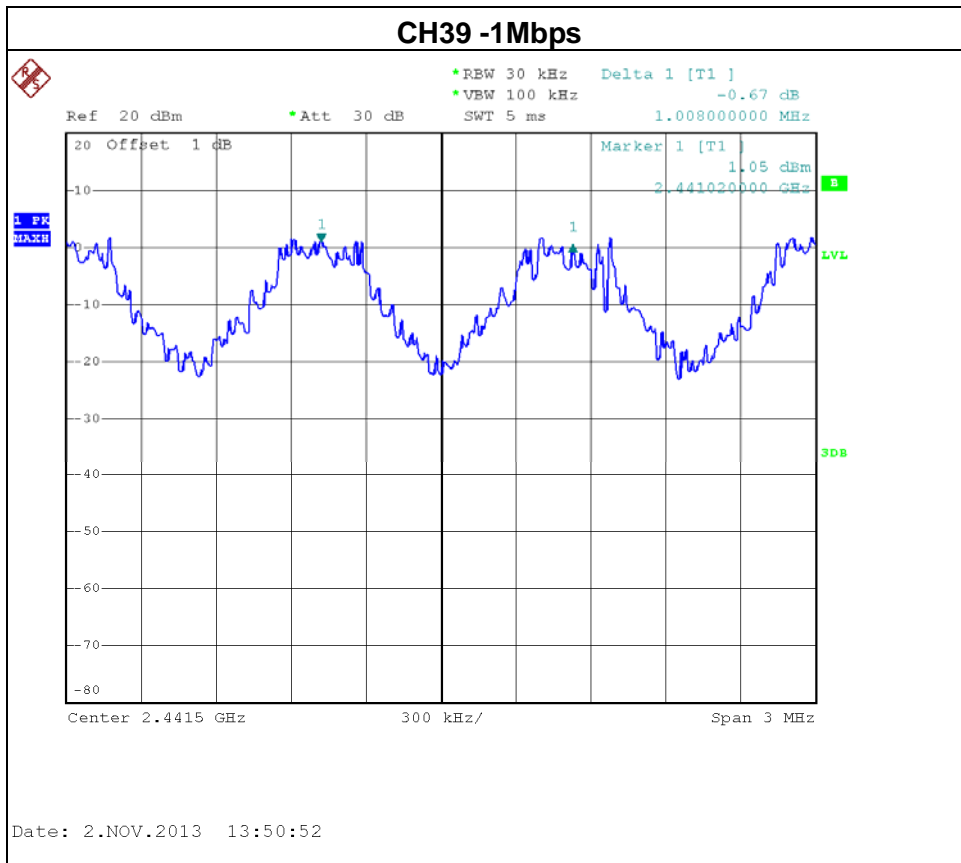



| | | | |
|--------------|-------------------------------------|--------------------|---------|
| EUT: | Cisco TelePresence Touch 10 | Model Name: | TTC5-09 |
| Temperature: | 25 °C | Relative Humidity: | 58 % |
| Pressure: | 1009 hPa | Test Voltage: | DC 48V |
| Test Mode: | Hopping on -CH00 / CH39 /CH78-3Mbps | | |

| Frequency (MHz) | Ch. Separation (MHz) | 2/3 of the 20 dB bandwidth (MHz) | Result |
|-----------------|----------------------|----------------------------------|-----------------|
| 2402 | 1.002 | 0.880 | Complies |
| 2441 | 0.996 | 0.887 | Complies |
| 2480 | 1.002 | 0.880 | Complies |

Ch. Separation Limit: >20dB bandwidth or >2/3 of the 20 dB bandwidth

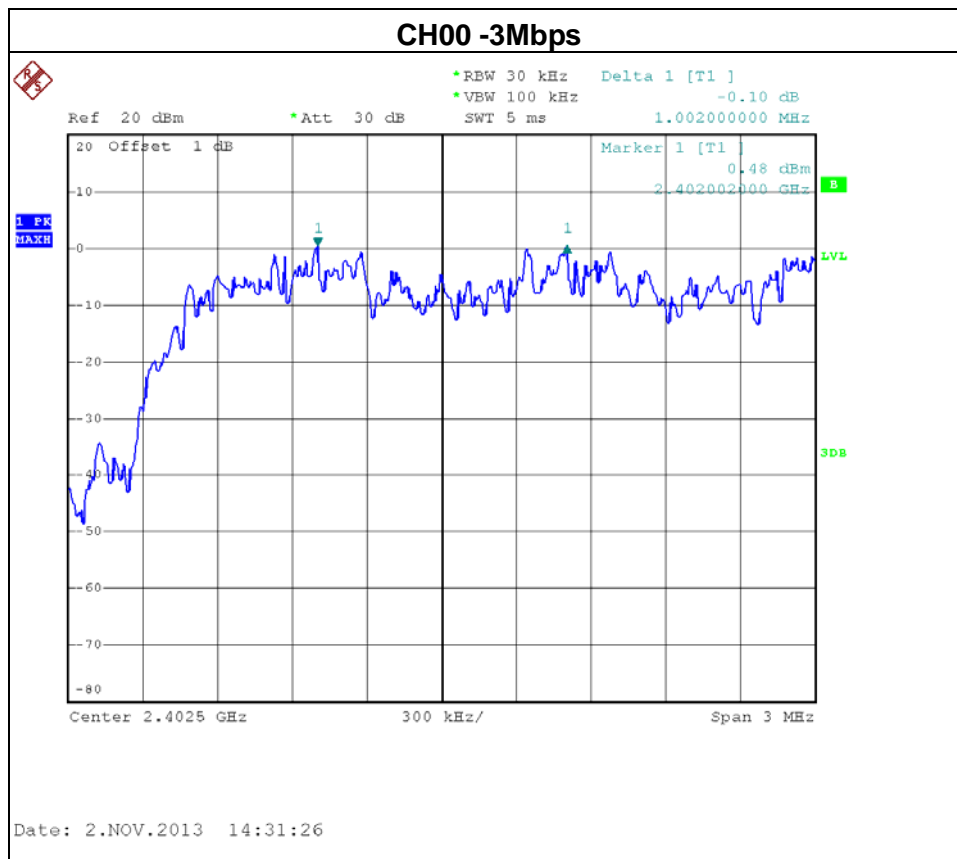

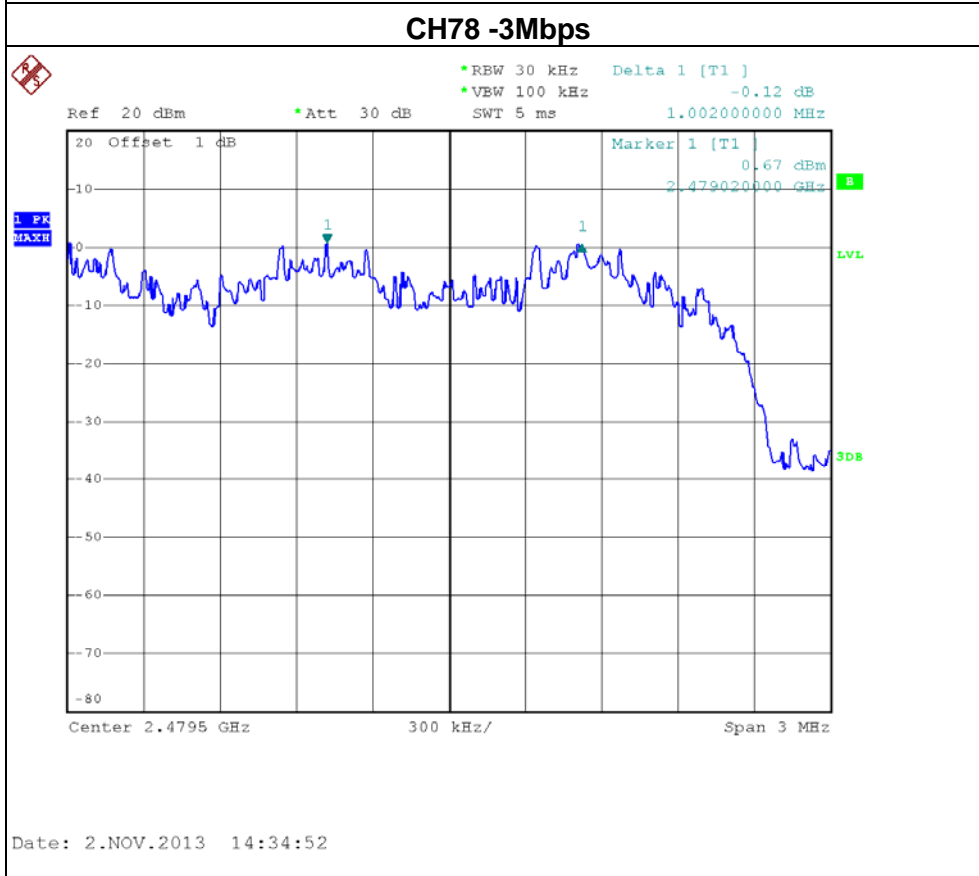
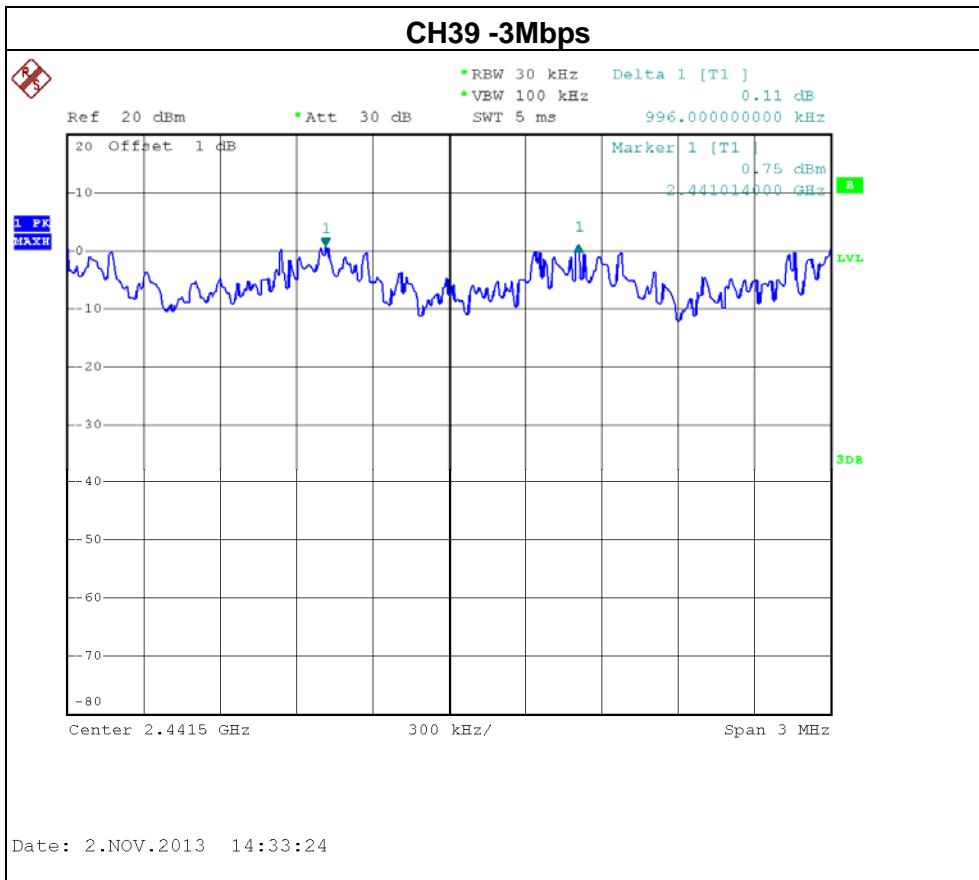



8. BANDWIDTH TEST

8.1 APPLIED PROCEDURES

| FCC Part15 (15.247) , Subpart C/ RSS-GEN and RSS-210 | | |
|---|-----------|-----------------------|
| Section | Test Item | Frequency Range (MHz) |
| 15.247(a)(2) RSS-GEN section 4.6.1 RSS-210, Issue 8, Annex 8, A8.1(b) | Bandwidth | 2400-2483.5 |

8.1.1 MEASUREMENT INSTRUMENTS LIST AND SETTING

| Item | Kind of Equipment | Manufacturer | Type No. | Serial No. | Calibrated until |
|------|-------------------|--------------|----------|------------|------------------|
| 1 | Spectrum Analyzer | R&S | FSP 40 | 100185 | Nov. 16, 2013 |

Remark: "N/A" denotes no model name, serial no. or calibration specified.
All calibration period of equipment list is one year.

| Spectrum Parameter | Setting |
|--------------------|---|
| Attenuation | Auto |
| Span Frequency | > Measurement Bandwidth or Channel Separation |
| RBW | 30 KHz (20dB Bandwidth) / 30 KHz (Channel Separation) |
| VBW | 100 KHz (20dB Bandwidth) / 100 KHz (Channel Separation) |
| Detector | Peak |
| Trace | Max Hold |
| Sweep Time | Auto |

8.1.2 TEST PROCEDURE

- a. The EUT was directly connected to the spectrum analyzer and antenna output port as show in the block diagram below,
- b. Spectrum Setting: RBW= 30KHz, VBW=100KHz, Sweep time = Auto.

8.1.3 DEVIATION FROM STANDARD

No deviation.

8.1.4 TEST SETUP



8.1.5 EUT OPERATION CONDITIONS

The EUT tested system was configured as the statements of 4.1.6 Unless otherwise a special operating condition is specified in the follows during the testing.



8.1.6 TEST RESULTS

| | | | |
|--------------|-----------------------------|--------------------|---------|
| EUT: | Cisco TelePresence Touch 10 | Model Name: | TTC5-09 |
| Temperature: | 25 °C | Relative Humidity: | 58 % |
| Pressure: | 1009 hPa | Test Voltage: | DC 48V |
| Test Mode: | CH00 / CH39 /CH78-1Mbps | | |

| Test Channel | Frequency (MHz) | 20dB Bandwidth (MHz) | 99% Occupied Bandwidth (MHz) | Result |
|--------------|-----------------|----------------------|------------------------------|--------|
| CH00 | 2402 | 0.94 | 0.82 | PASS |
| CH39 | 2441 | 0.95 | 0.83 | PASS |
| CH78 | 2480 | 0.94 | 0.83 | PASS |

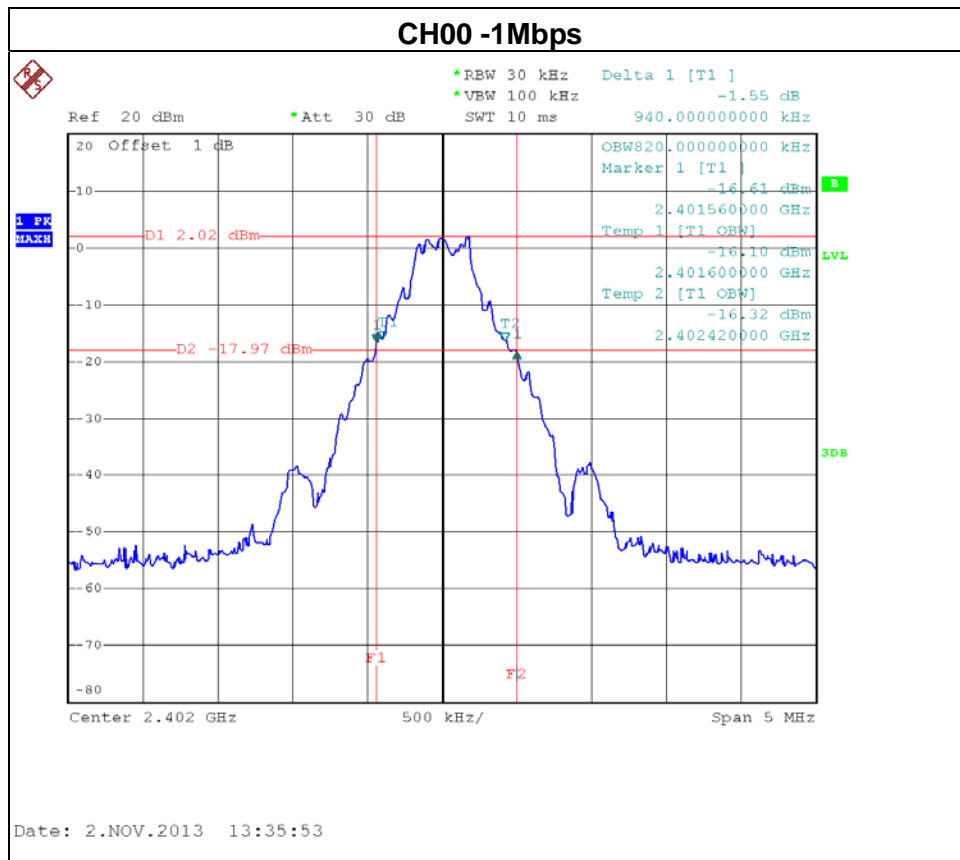



| | | | |
|--------------|-----------------------------|--------------------|---------|
| EUT: | Cisco TelePresence Touch 10 | Model Name: | TTC5-09 |
| Temperature: | 25 °C | Relative Humidity: | 58 % |
| Pressure: | 1009 hPa | Test Voltage: | DC 48V |
| Test Mode: | CH00 / CH39 /CH78-3Mbps | | |

| Test Channel | Frequency (MHz) | 20dB Bandwidth (MHz) | 99% Occupied Bandwidth (MHz) | Result |
|--------------|-----------------|----------------------|------------------------------|--------|
| CH00 | 2402 | 1.32 | 1.14 | PASS |
| CH39 | 2441 | 1.33 | 1.18 | PASS |
| CH78 | 2480 | 1.32 | 1.18 | PASS |

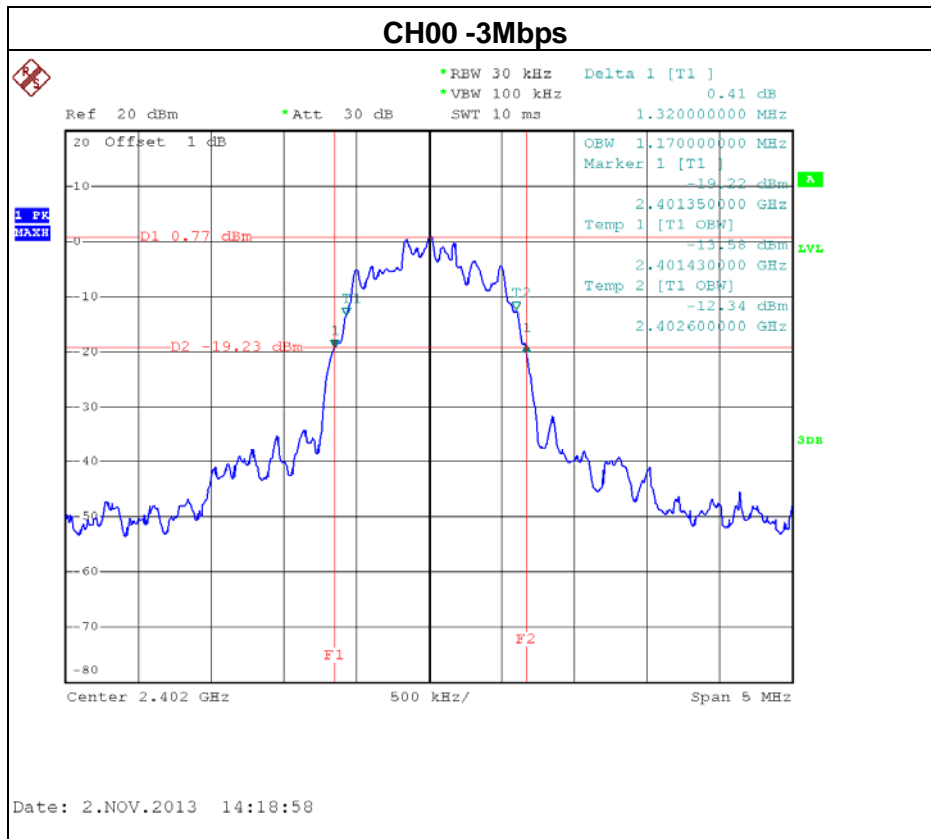

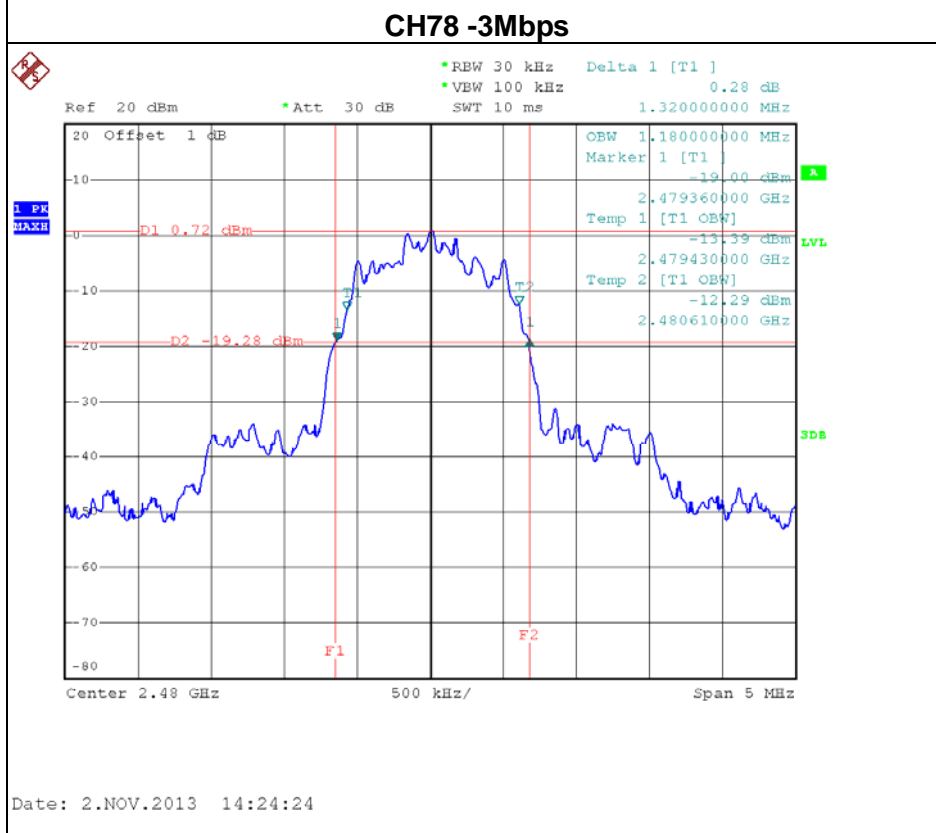
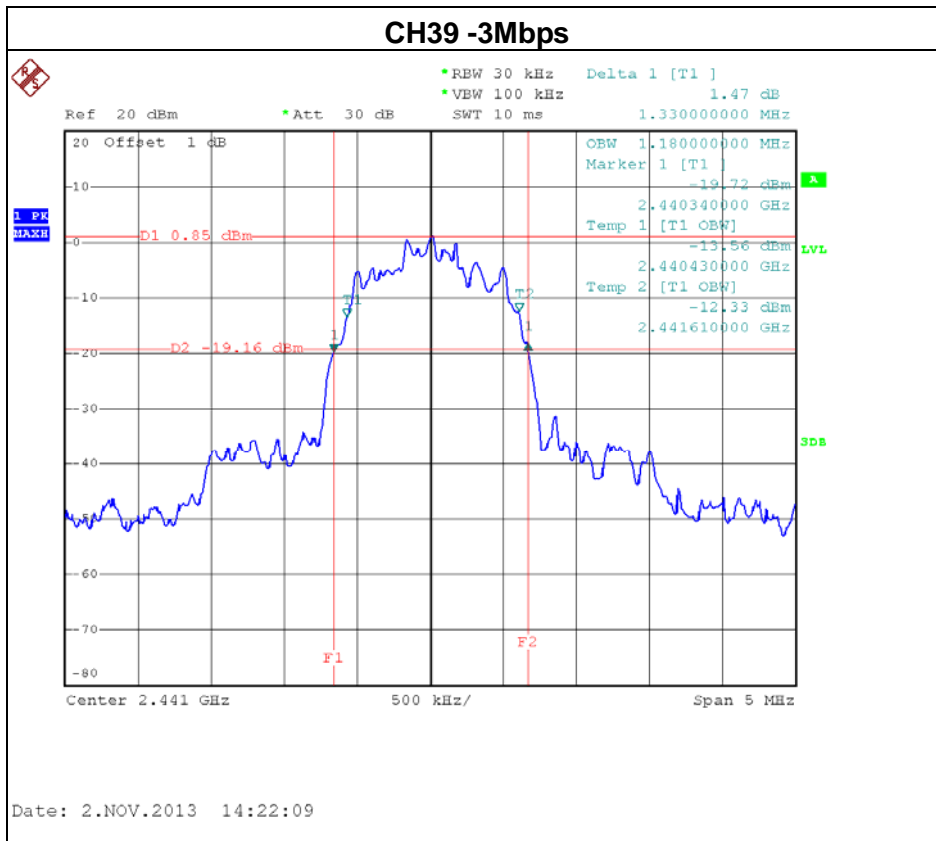



9. PEAKOUTPUT POWER TEST

9.1 APPLIED PROCEDURES / LIMIT

| FCC Part15 (15.247) , Subpart C/ RSS-GEN and RSS-210 | | | | |
|--|-------------------|------------------------|-----------------------|--------|
| Section | Test Item | Limit | Frequency Range (MHz) | Result |
| 15.247(b)(1) RSS-GEN section 4.8 RSS-210, Issue 8, Annex 8, A8.1(b) | Peak Output Power | 0.125 Watt or 21dBm | 2400-2483.5 | PASS |

9.1.1 MEASUREMENT INSTRUMENTS LIST AND SETTING

| Item | Kind of Equipment | Manufacturer | Type No. | Serial No. | Calibrated until |
|------|-------------------|--------------|----------|------------|------------------|
| 1 | Spectrum Analyzer | R&S | FSP 40 | 100185 | Nov. 16, 2013 |

Remark: "N/A" denotes no model name, serial no. or calibration specified.
All calibration period of equipment list is one year.

9.1.2 TEST PROCEDURE

- a. The EUT was directly connected to the spectrum analyzer and antenna output port as show in the block diagram below,
- b. Spectrum Setting: RBW= 1MHz/3MHz, VBW= 1MHz/3MHz, Sweep time = Auto.

9.1.3 DEVIATION FROM STANDARD

No deviation.

9.1.4 TEST SETUP



9.1.5 EUT OPERATION CONDITIONS

The EUT tested system was configured as the statements of 4.1.6 Unless otherwise a special operating condition is specified in the follows during the testing.



9.1.6 TEST RESULTS

| | | | |
|--------------|-----------------------------|--------------------|---------|
| EUT: | Cisco TelePresence Touch 10 | Model Name: | TTC5-09 |
| Temperature: | 25 °C | Relative Humidity: | 58 % |
| Pressure: | 1009 hPa | Test Voltage: | DC 48V |
| Test Mode: | CH00/ CH39 /CH78 -1Mbps | | |

| Test Channel | Frequency (MHz) | Peak Output Power (dBm) | Limit (dBm) | Limit (Watt) |
|--------------|-----------------|-------------------------|-------------|--------------|
| CH00 | 2402 | 5.04 | 21 | 0.125 |
| CH39 | 2441 | 5.13 | 21 | 0.125 |
| CH78 | 2480 | 5.09 | 21 | 0.125 |

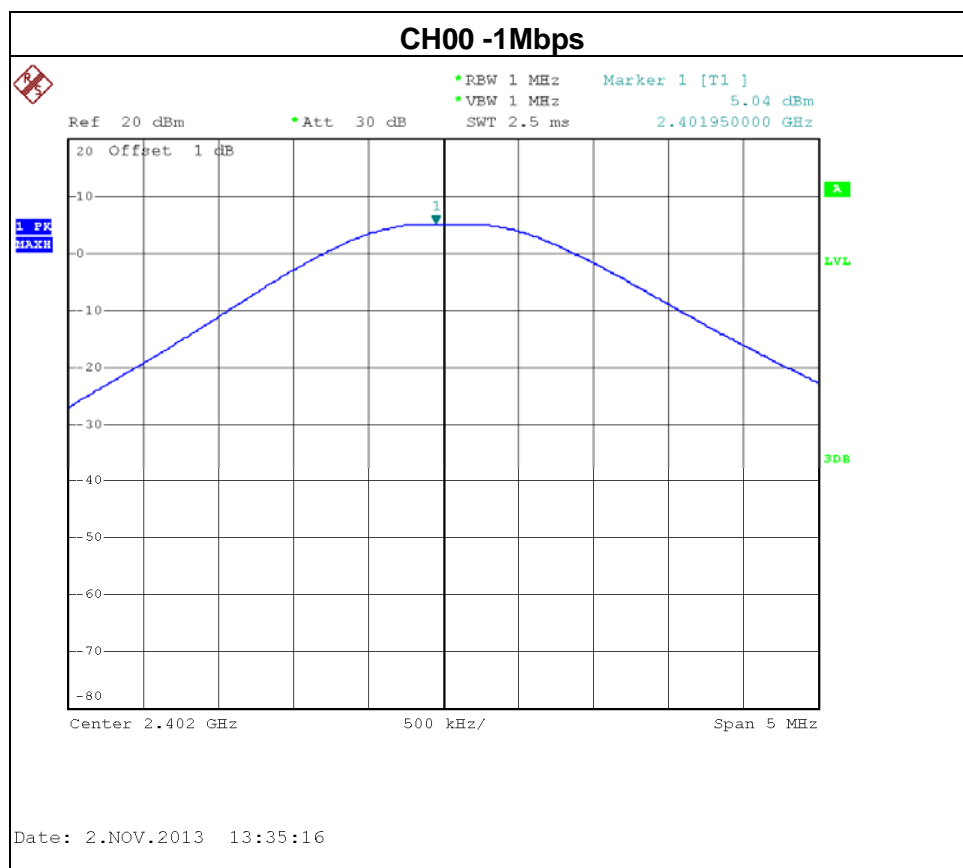

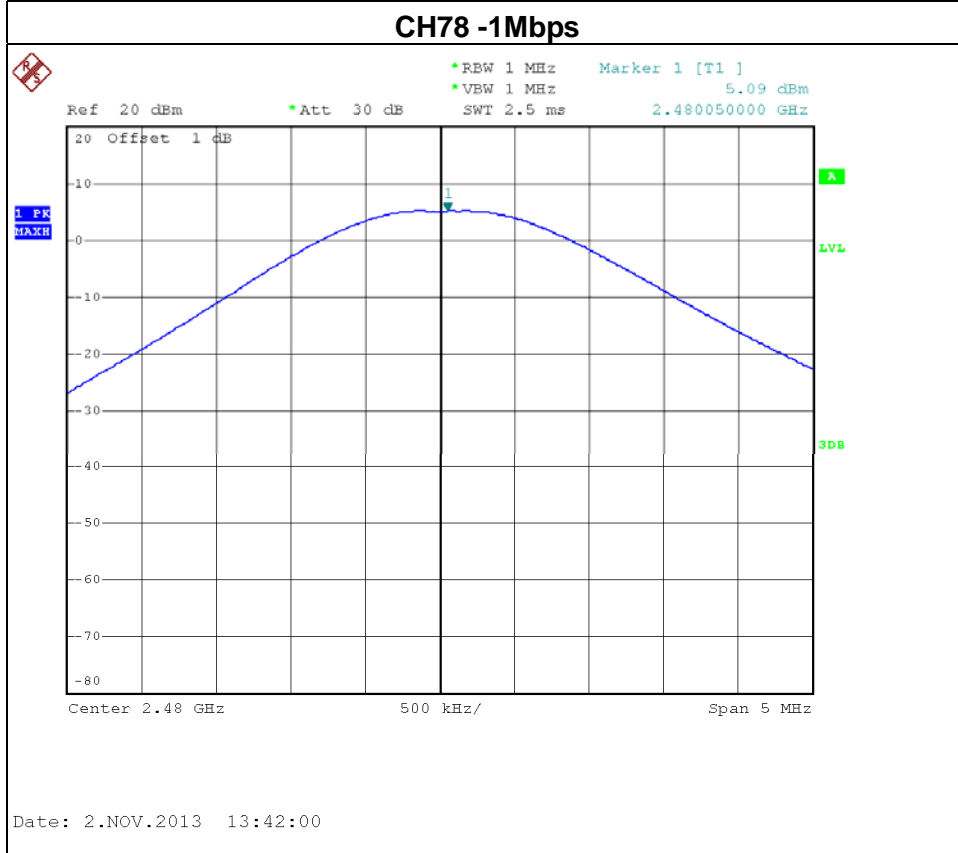
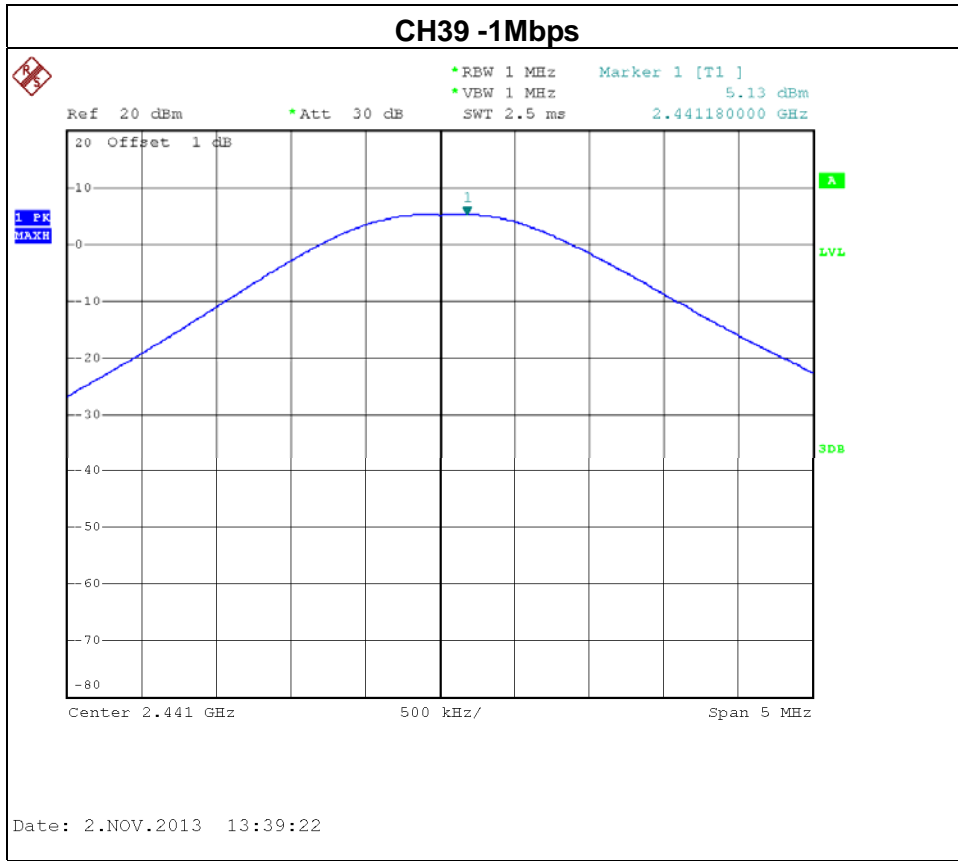



| | | | |
|--------------|-----------------------------|--------------------|---------|
| EUT: | Cisco TelePresence Touch 10 | Model Name: | TTC5-09 |
| Temperature: | 25 °C | Relative Humidity: | 58 % |
| Pressure: | 1009 hPa | Test Voltage: | DC 48V |
| Test Mode: | CH00/ CH39 /CH78 -3Mbps | | |

| Test Channel | Frequency (MHz) | Peak Output Power (dBm) | Limit (dBm) | Limit (Watt) |
|--------------|-----------------|-------------------------|-------------|--------------|
| CH00 | 2402 | 6.73 | 21 | 0.125 |
| CH39 | 2441 | 6.57 | 21 | 0.125 |
| CH78 | 2480 | 6.30 | 21 | 0.125 |

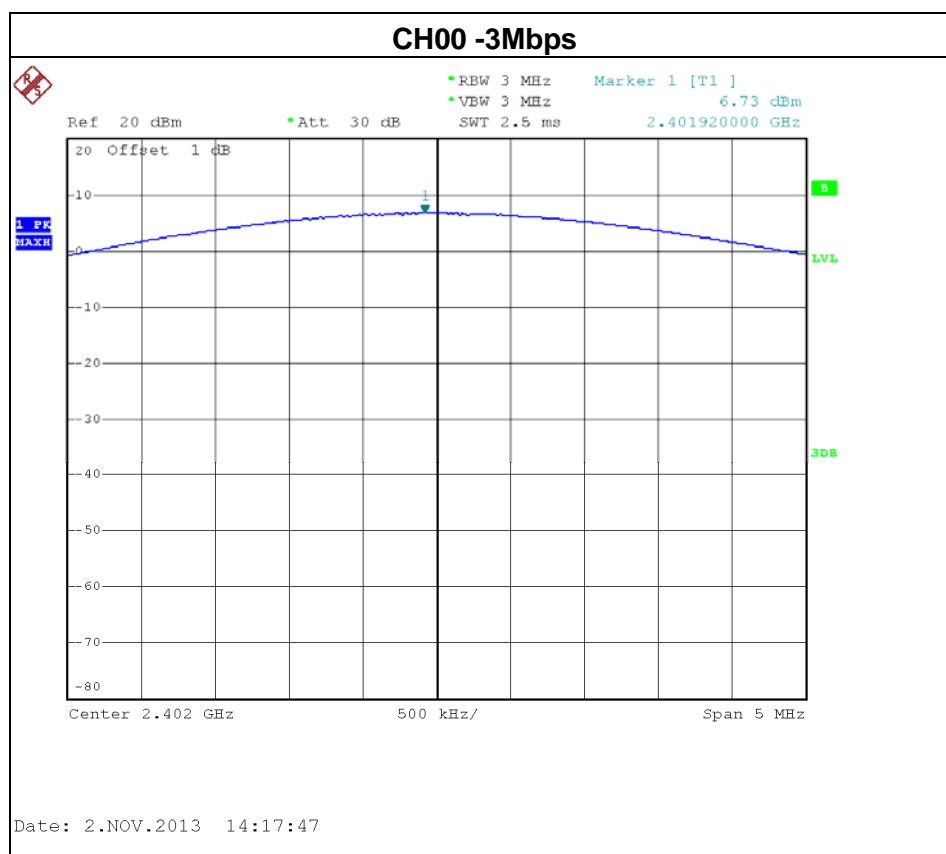

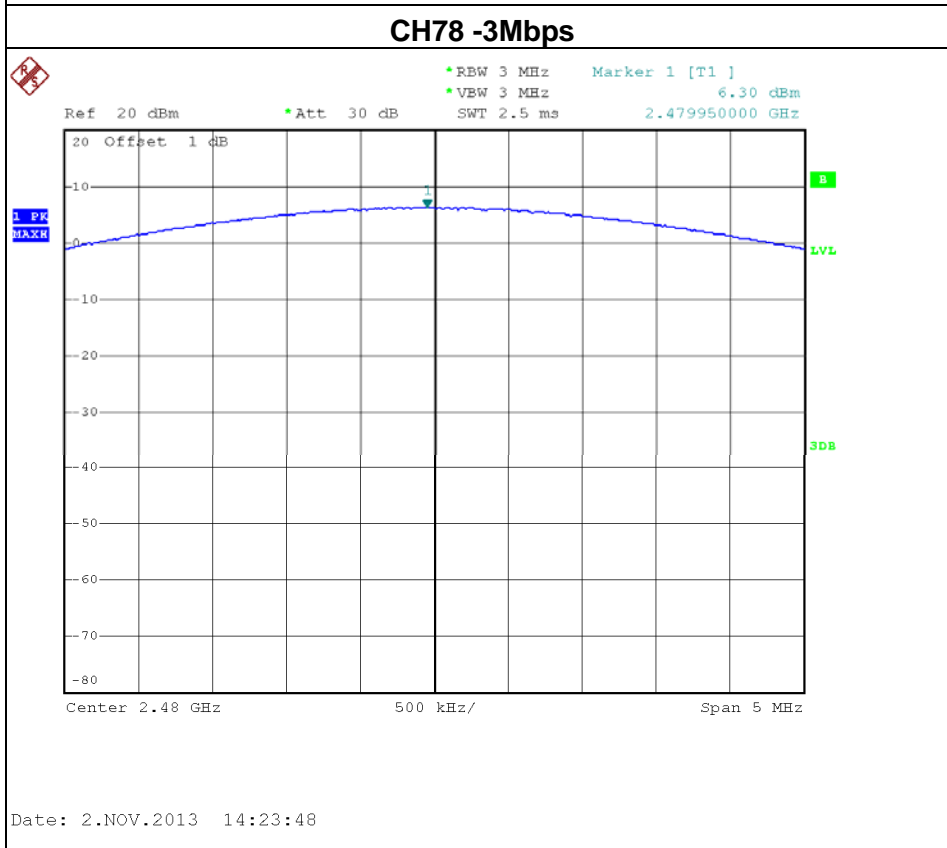
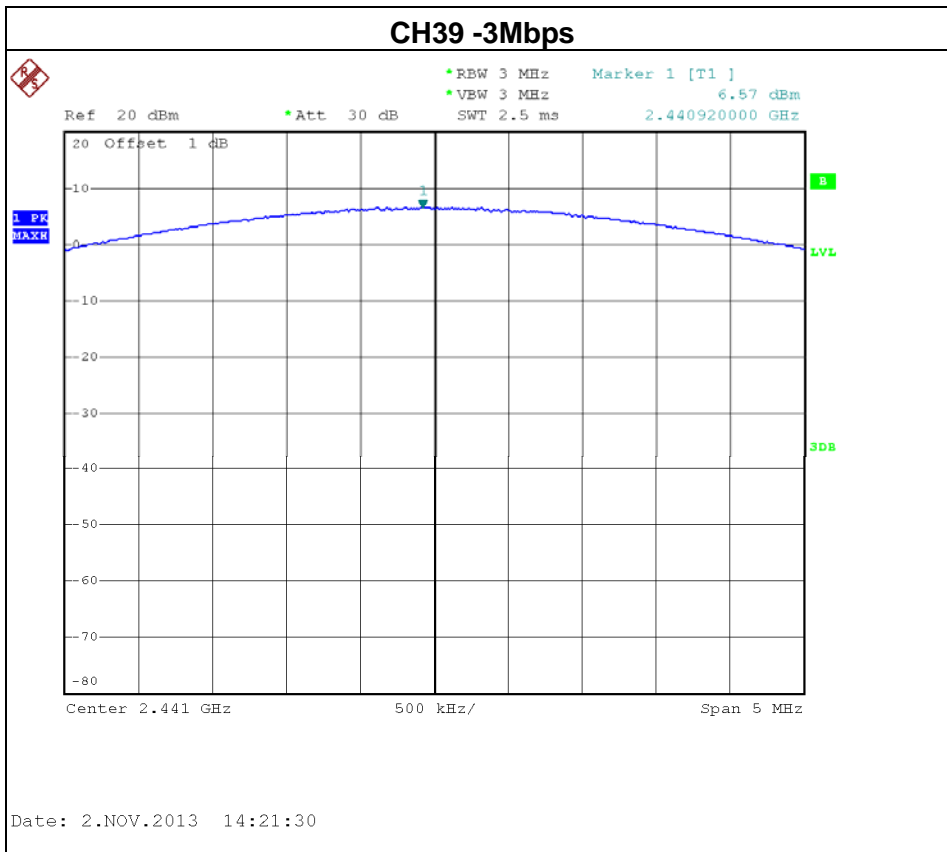



10. ANTENNA CONDUCTED SPURIOUS EMISSION

10.1 APPLIED PROCEDURES / LIMIT

20dB in any 100 KHz bandwidth outside the operating frequency band, In case the emission fall within the restricted band specified on 15.205(a) & RSS-210 section 2.2& Annex 8, A8.5, then the 15.209(a) & RSS-GEN limit in the table below has to be followed.

| Frequency (MHz) | Field Strength (microvolts/meter) | Measurement Distance (meters) |
|-----------------|-----------------------------------|-------------------------------|
| 0.009~0.490 | 2400/F(KHz) | 300 |
| 0.490~1.705 | 24000/F(KHz) | 30 |
| 1.705~30.0 | 30 | 30 |
| 30~88 | 100 | 3 |
| 88~216 | 150 | 3 |
| 216~960 | 200 | 3 |
| 960~1000 | 500 | 3 |

LIMITS OF RADIATED EMISSION MEASUREMENT (Above 1000MHz)

| Frequency (MHz) | (dBuV/m) (at 3 meters) | |
|-----------------|------------------------|---------|
| | Peak | Average |
| Above 1000 | 74 | 54 |

10.1.1 MEASUREMENT INSTRUMENTS LIST AND SETTING

| Item | Kind of Equipment | Manufacturer | Type No. | Serial No. | Calibrated until |
|------|-------------------|--------------|----------|------------|------------------|
| 1 | Spectrum Analyzer | R&S | FSP 40 | 100185 | Nov. 16, 2013 |

Remark: "N/A" denotes no model name, serial no. or calibration specified.
All calibration period of equipment list is one year.

10.1.2 TEST PROCEDURE

- a. The EUT was directly connected to the spectrum analyzer and antenna output port as show in the block diagram below,
- b. Spectrum Setting: RBW= 100KHz, VBW=100KHz, Sweep time = Auto.

10.1.3 DEVIATION FROM STANDARD

No deviation.



10.1.4 TEST SETUP

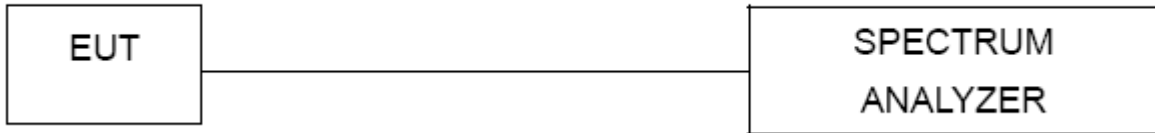

10.1.5 EUT OPERATION CONDITIONS

The EUT tested system was configured as the statements of 4.1.6 Unless otherwise a special operating condition is specified in the follows during the testing.



10.1.6 TEST RESULTS

| | | | |
|--------------|---|--------------------|---------|
| EUT: | Cisco TelePresence Touch 10 | Model Name: | TTC5-09 |
| Temperature: | 25 °C | Relative Humidity: | 58 % |
| Pressure: | 1009 hPa | Test Voltage: | DC 48V |
| Test Mode: | CH00 / CH39/ CH78-1Mbps & Hopping on mode (1Mbps) | | |

| | | | |
|---|------------|--|------------|
| The max. radio frequency power in any 100KHz bandwidth outside the frequency band | | The max. radio frequency power in any 100 KHz bandwidth within the frequency band. | |
| FREQUENCY(MHz) | POWER(dBm) | FREQUENCY(MHz) | POWER(dBm) |
| 2388.40 | -41.77 | 2483.50 | -48.06 |

Result

In any 100KHz bandwidth outside the frequency band, the radio frequency power is at least 20dB below that in the 100KHz bandwidth within the band that contains the highest level of the desired power.

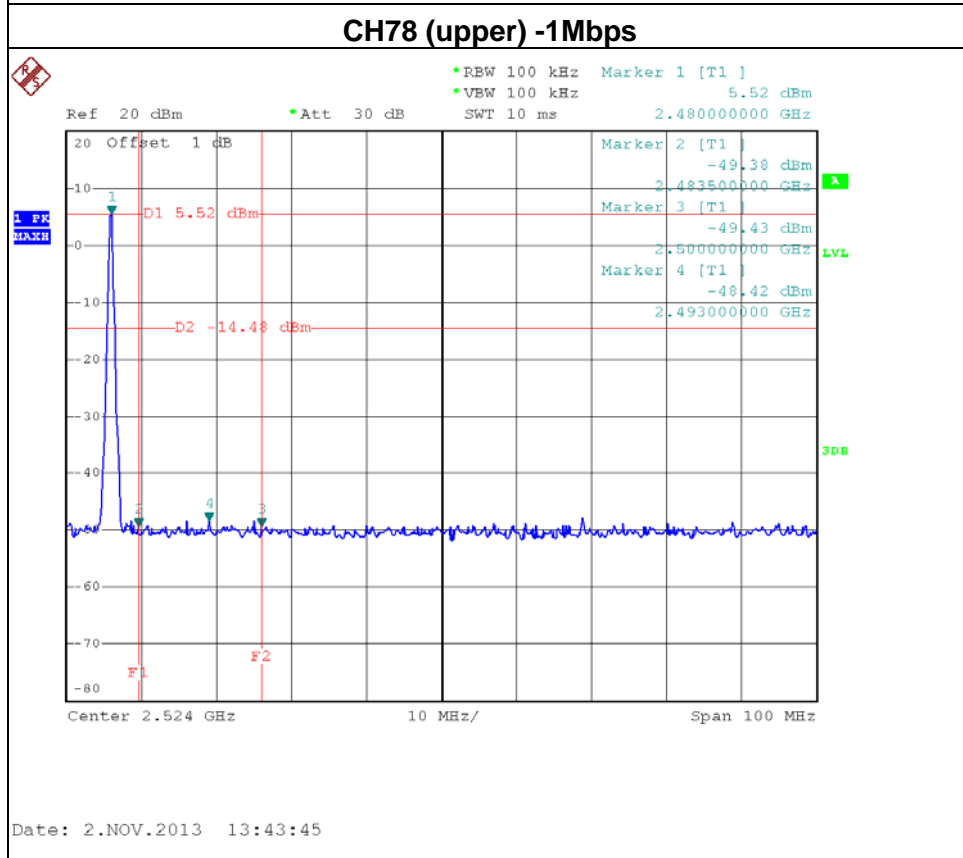
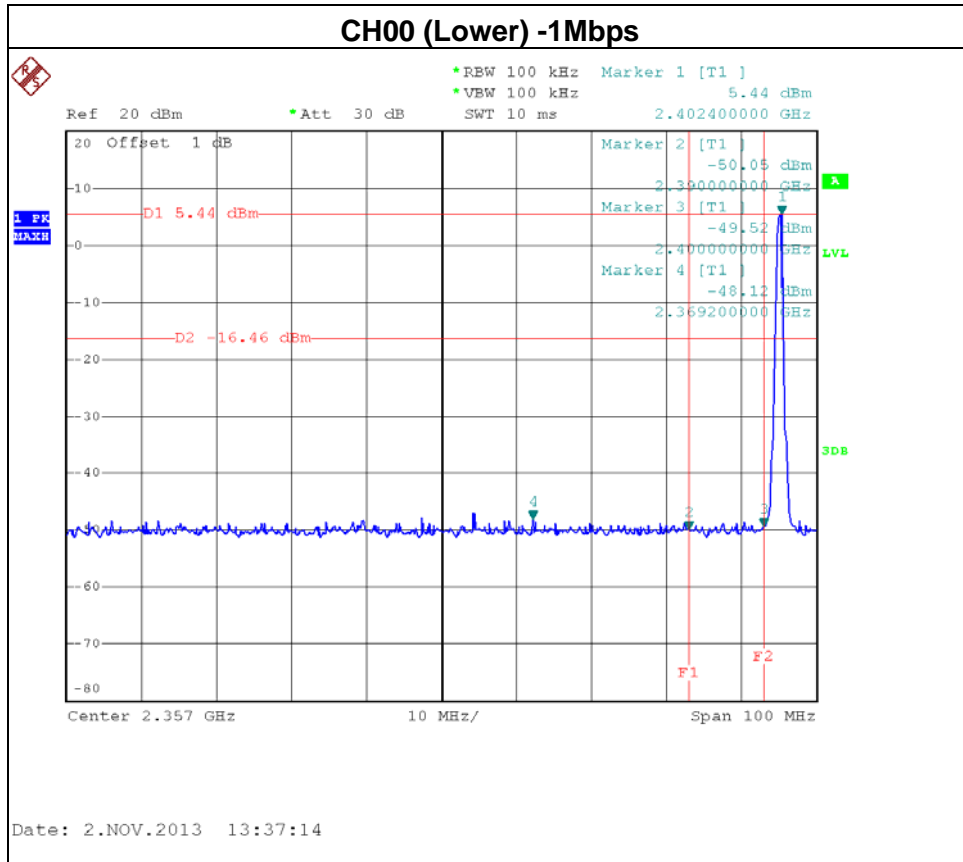



Hopping on mode (1Mbps- Lower)

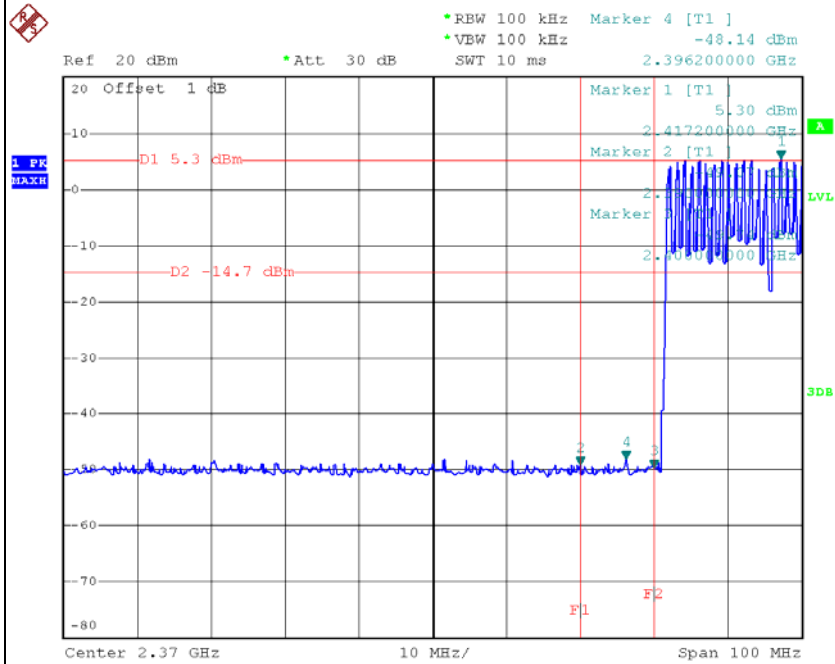

Date: 2.NOV.2013 13:52:39

Hopping on mode (1Mbps- upper)

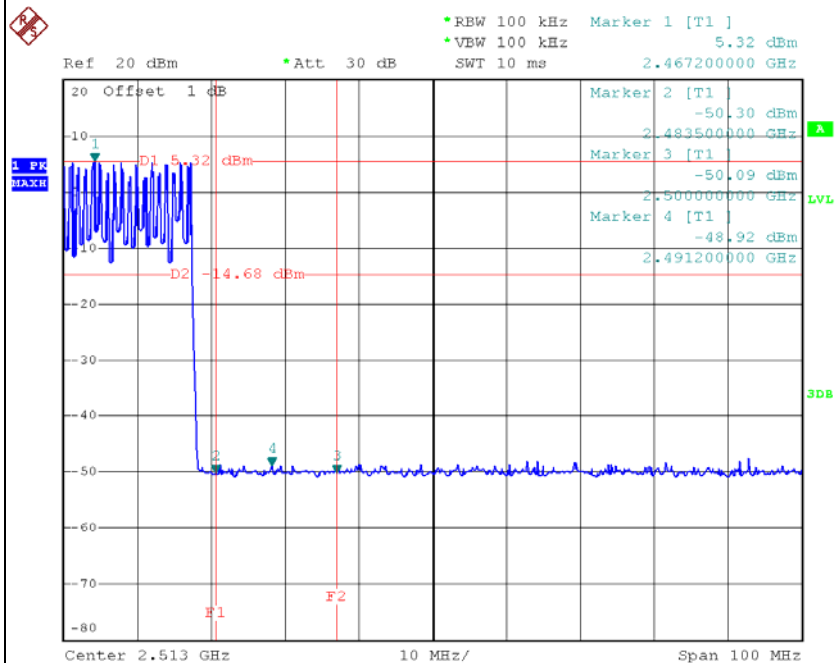

Date: 2.NOV.2013 13:53:54

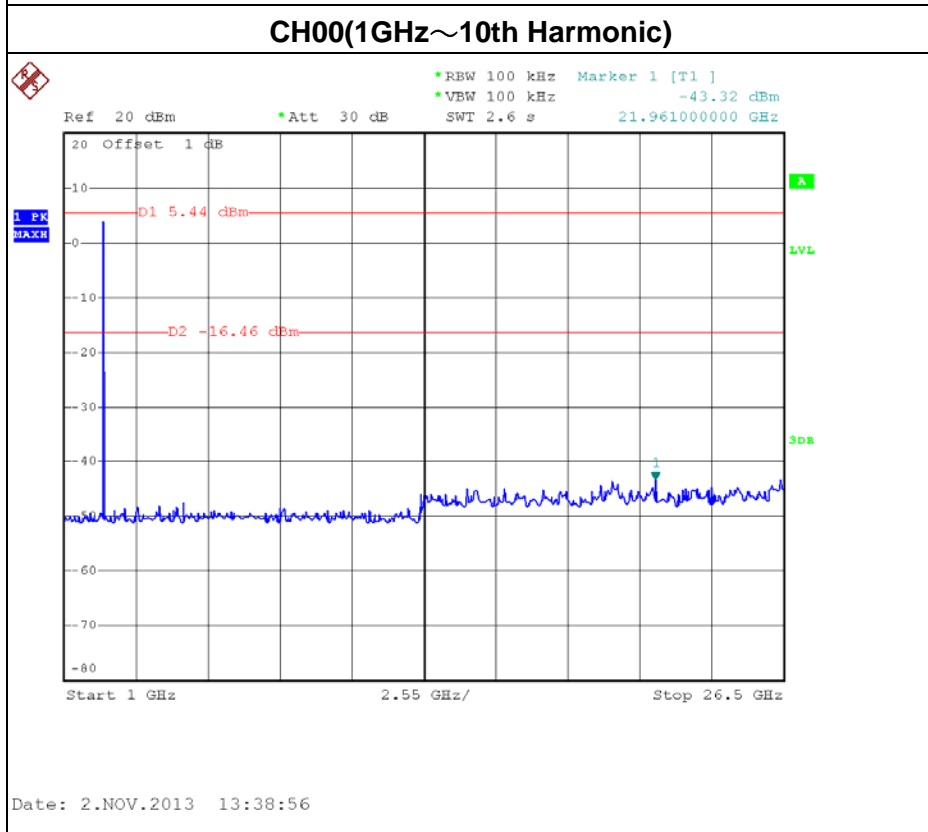
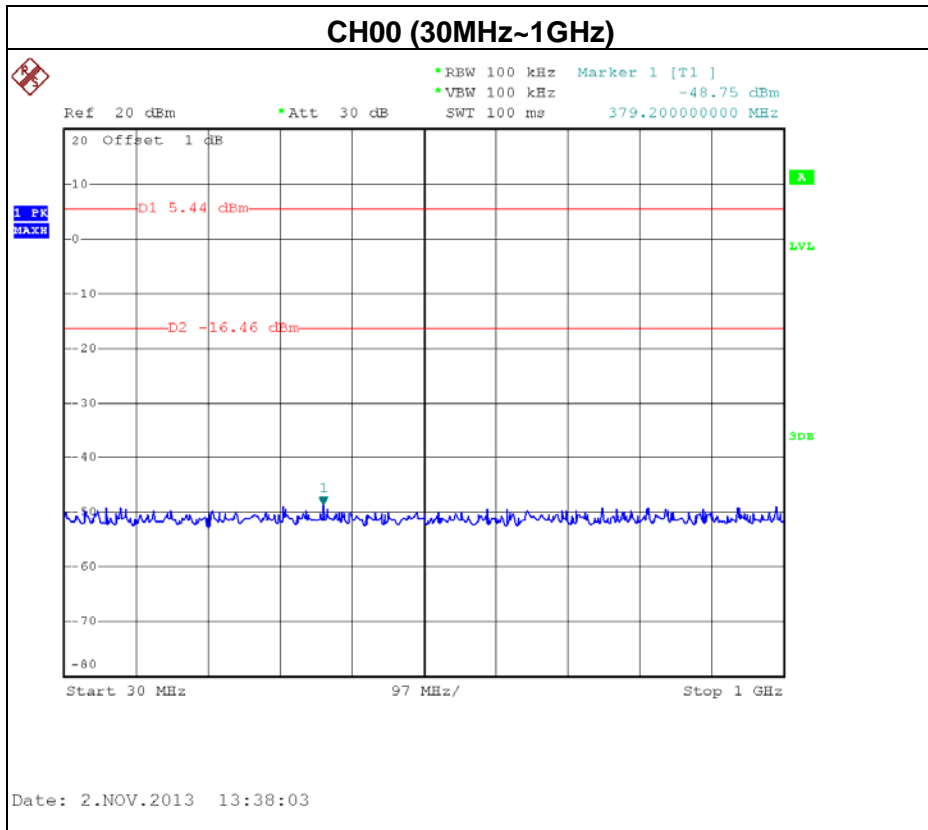

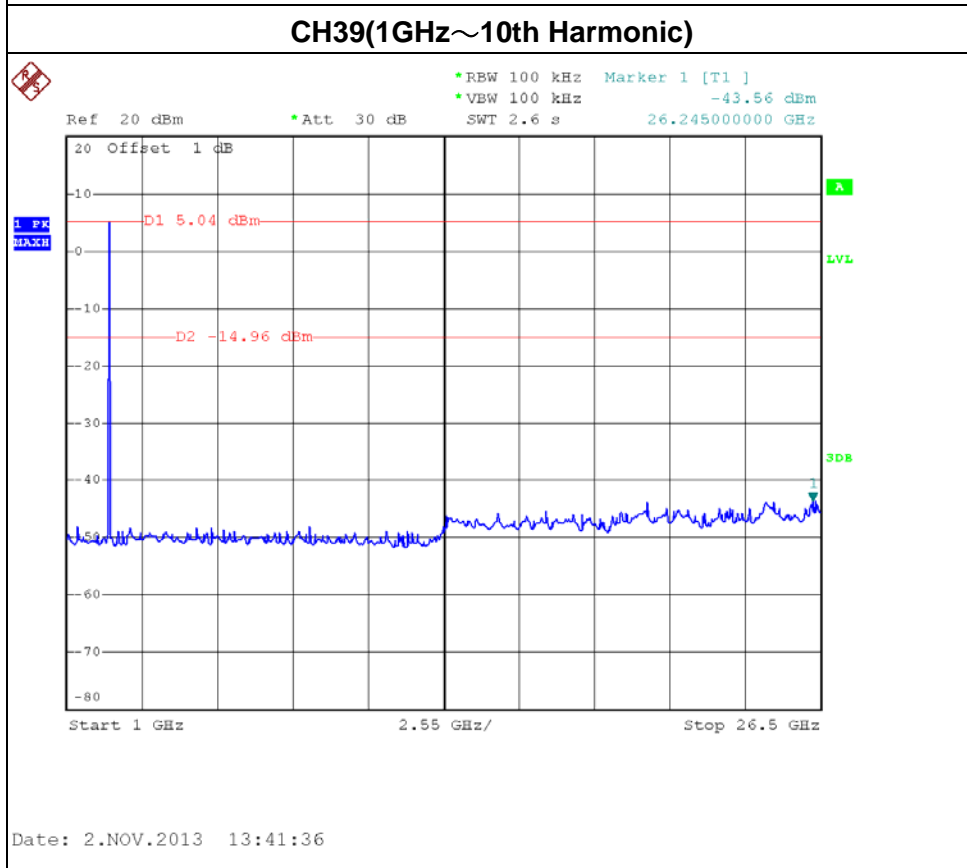
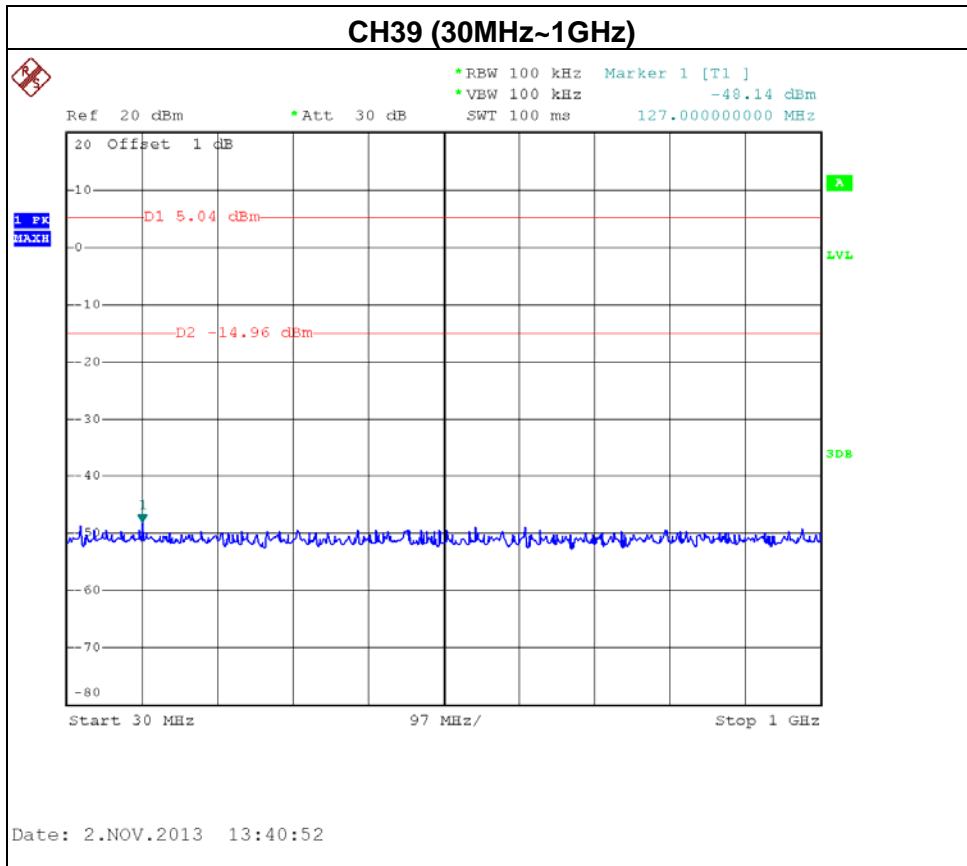

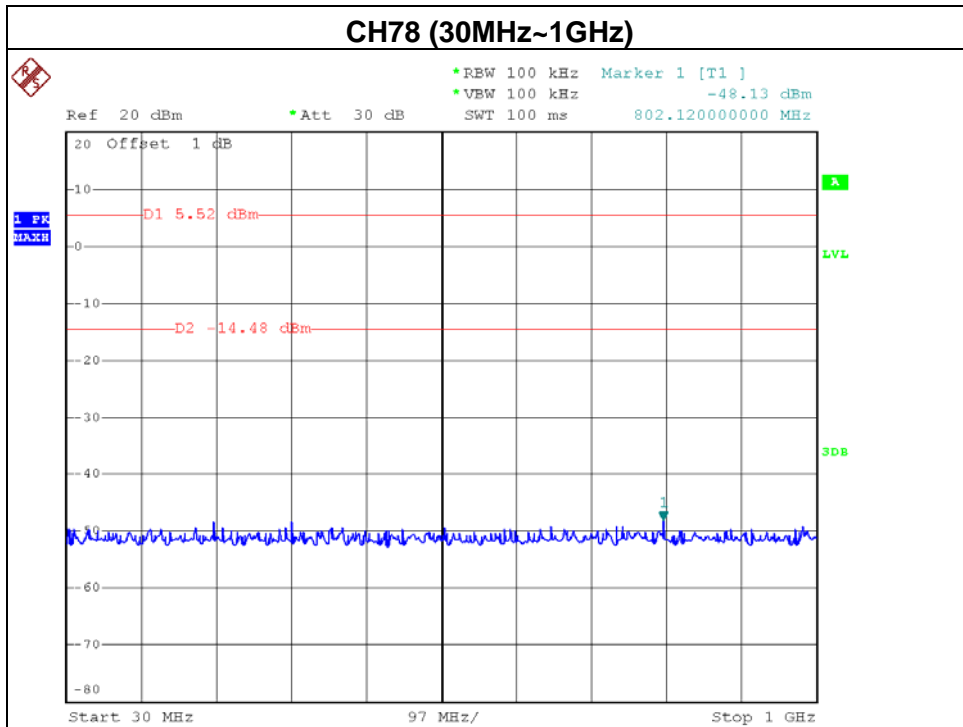

Date: 2.NOV.2013 13:44:00

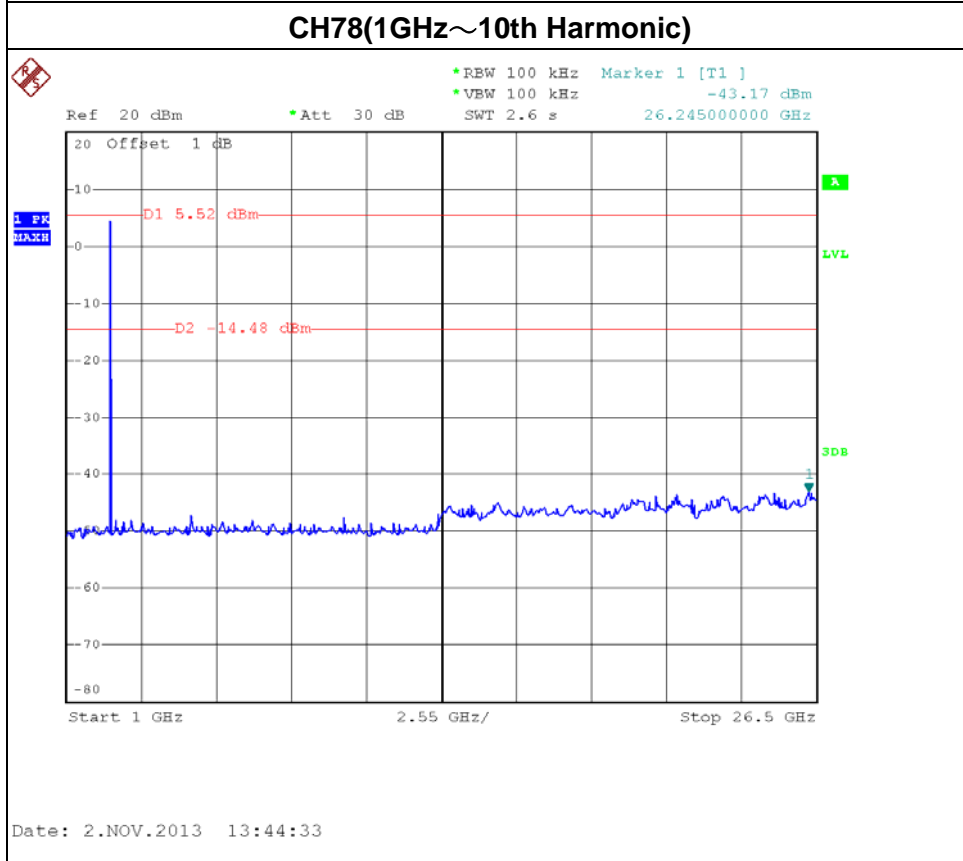

Date: 2.NOV.2013 13:44:33



| | | | |
|--------------|--|--------------------|---------|
| EUT: | Cisco TelePresence Touch 10 | Model Name: | TTC5-09 |
| Temperature: | 25 °C | Relative Humidity: | 58 % |
| Pressure: | 1009 hPa | Test Voltage: | DC 48V |
| Test Mode: | CH00 / CH39/ CH78 -3Mbps & Hopping on mode (3Mbps) | | |

| | | | |
|---|------------|--|------------|
| The max. radio frequency power in any 100KHz bandwidth outside the frequency band | | The max. radio frequency power in any 100 KHz bandwidth within the frequency band. | |
| FREQUENCY(MHz) | POWER(dBm) | FREQUENCY(MHz) | POWER(dBm) |
| 2400.00 | -57.86 | 2484.20 | -57.47 |

Result

In any 100KHz bandwidth outside the frequency band, the radio frequency power is at least 20dB below that in the 100KHz bandwidth within the band that contains the highest level of the desired power.

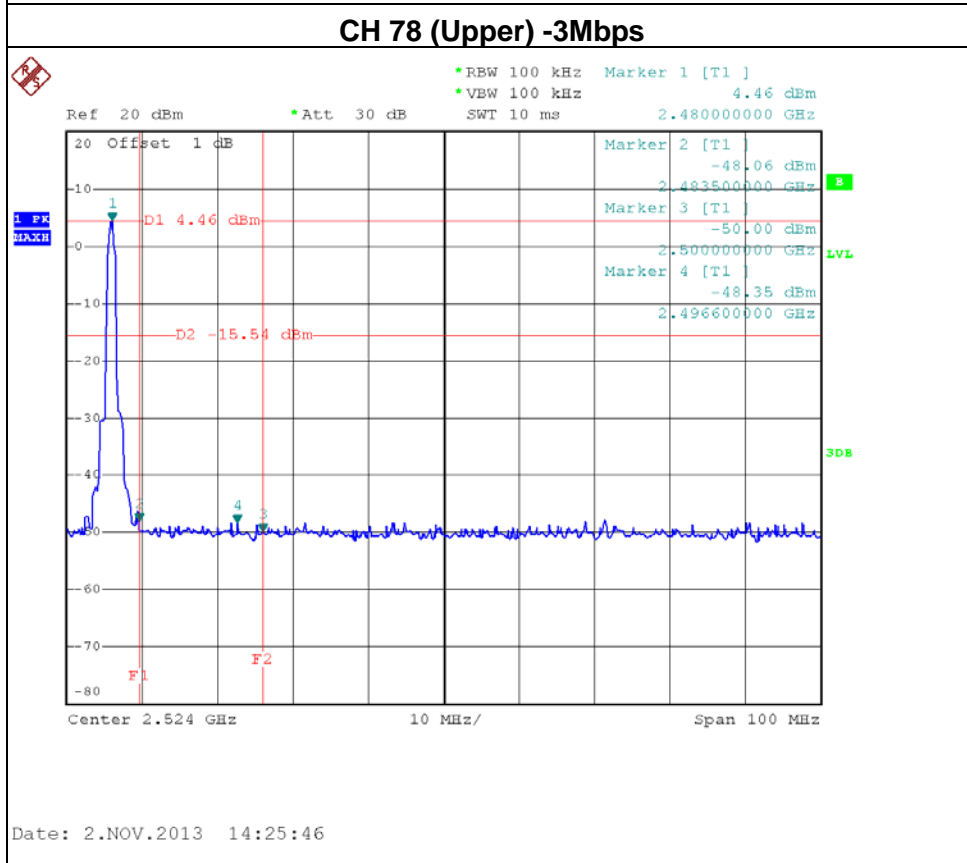
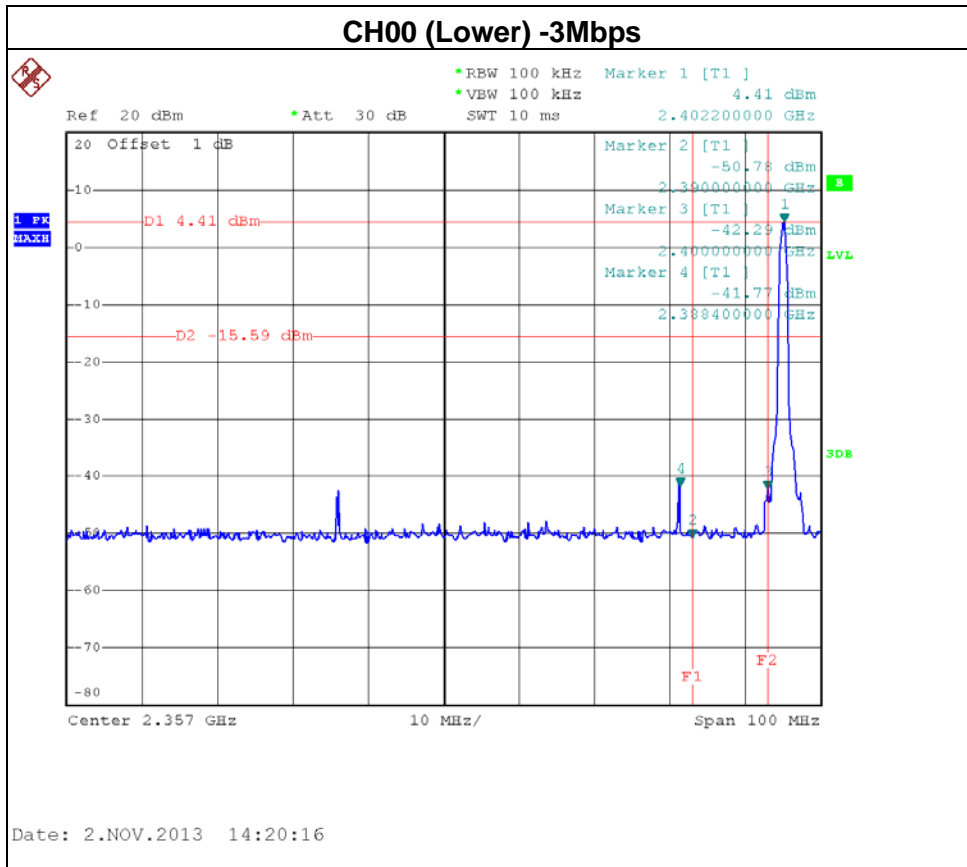

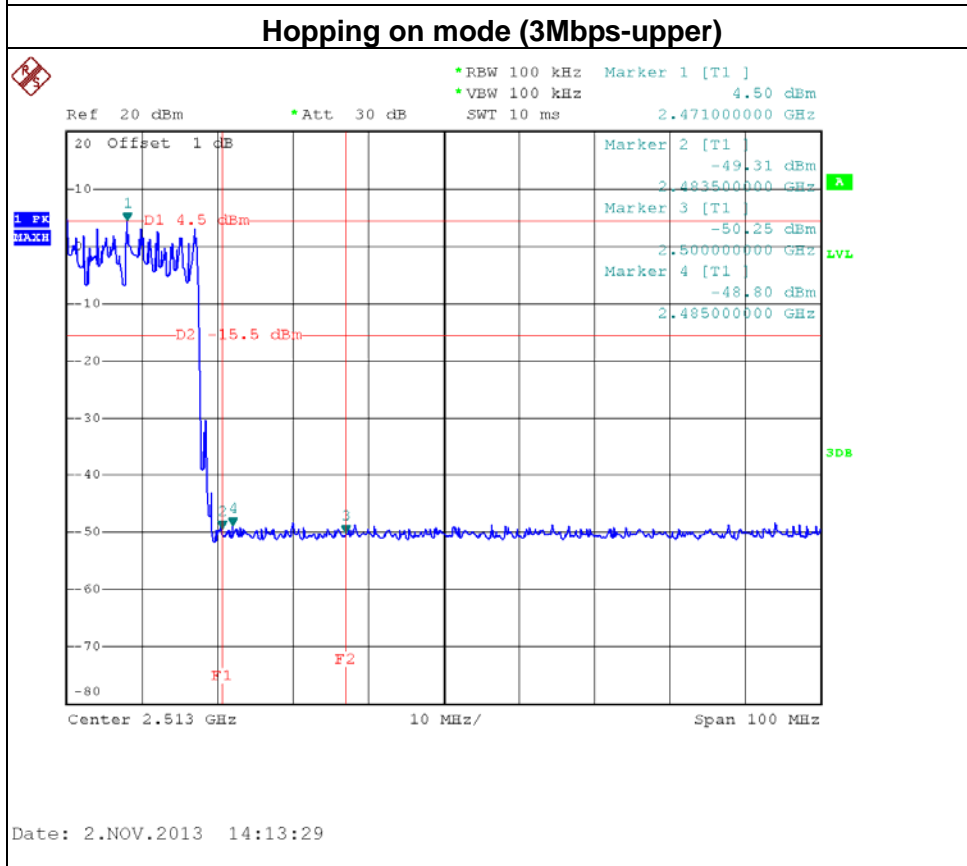
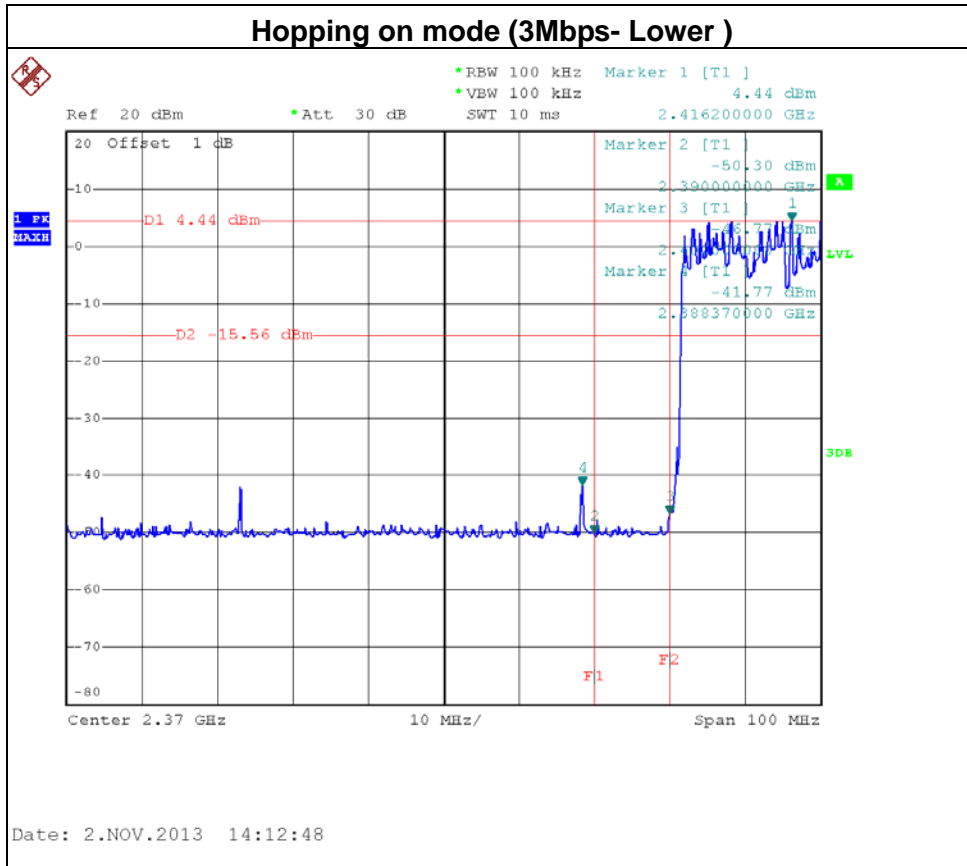

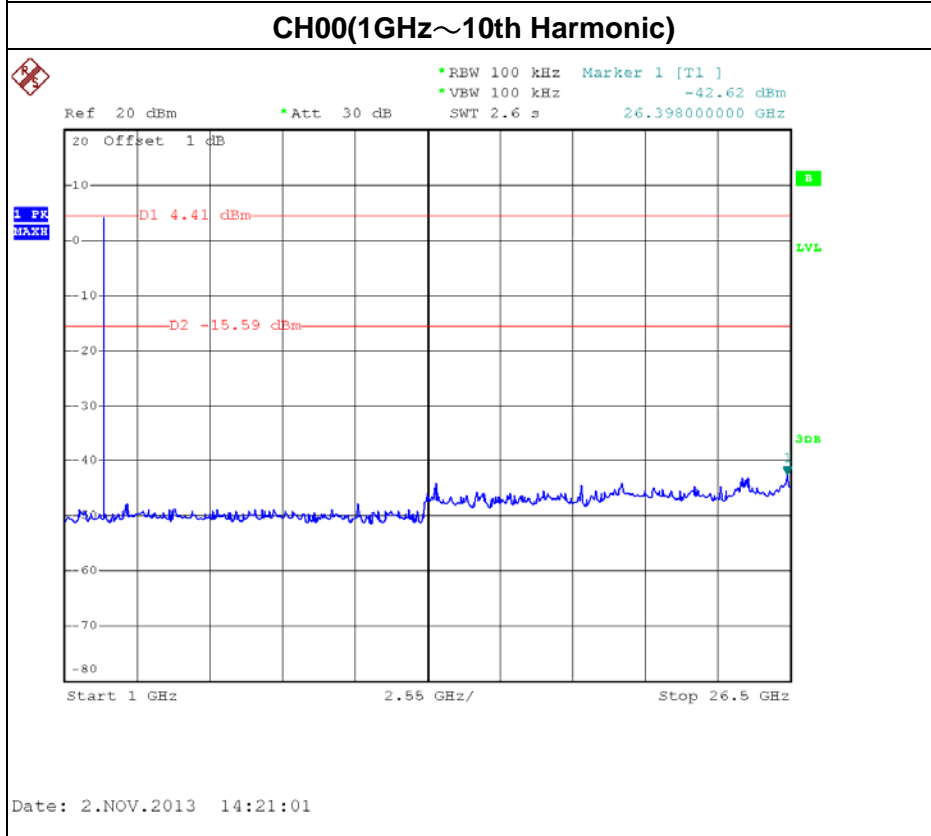
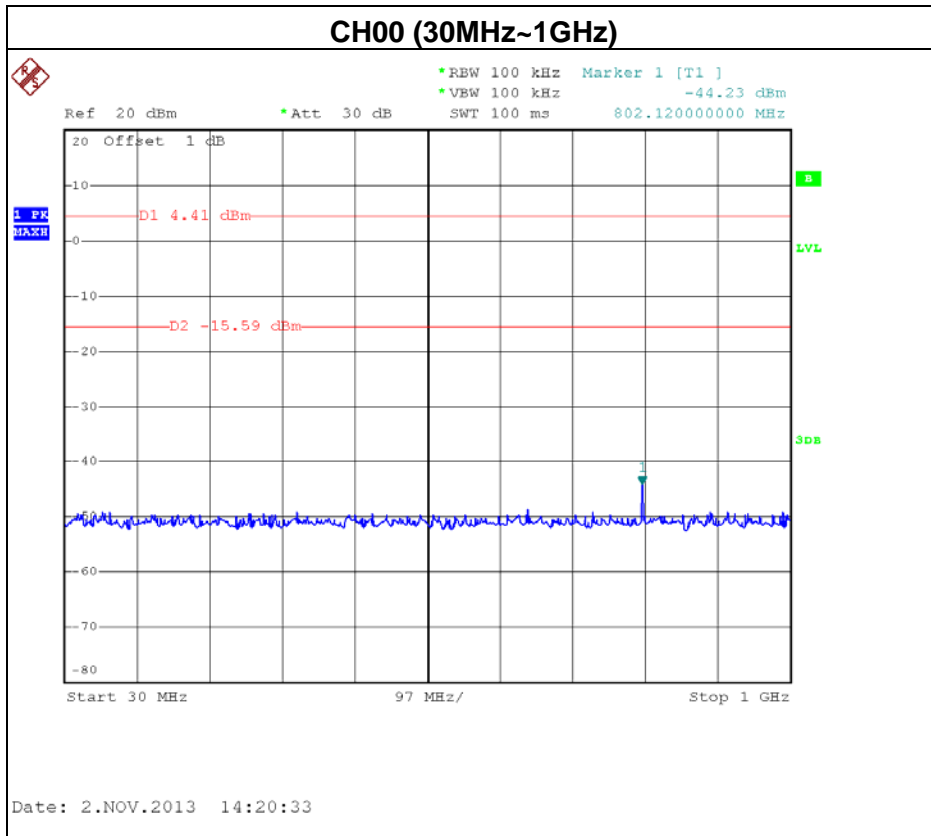

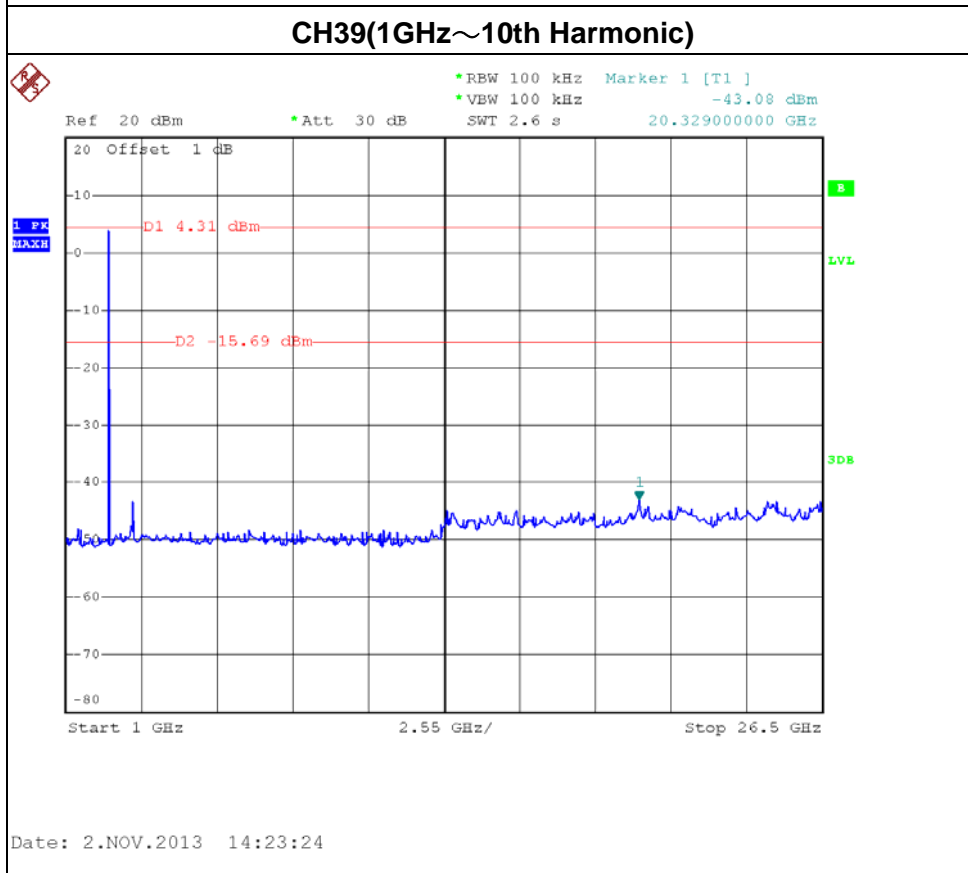
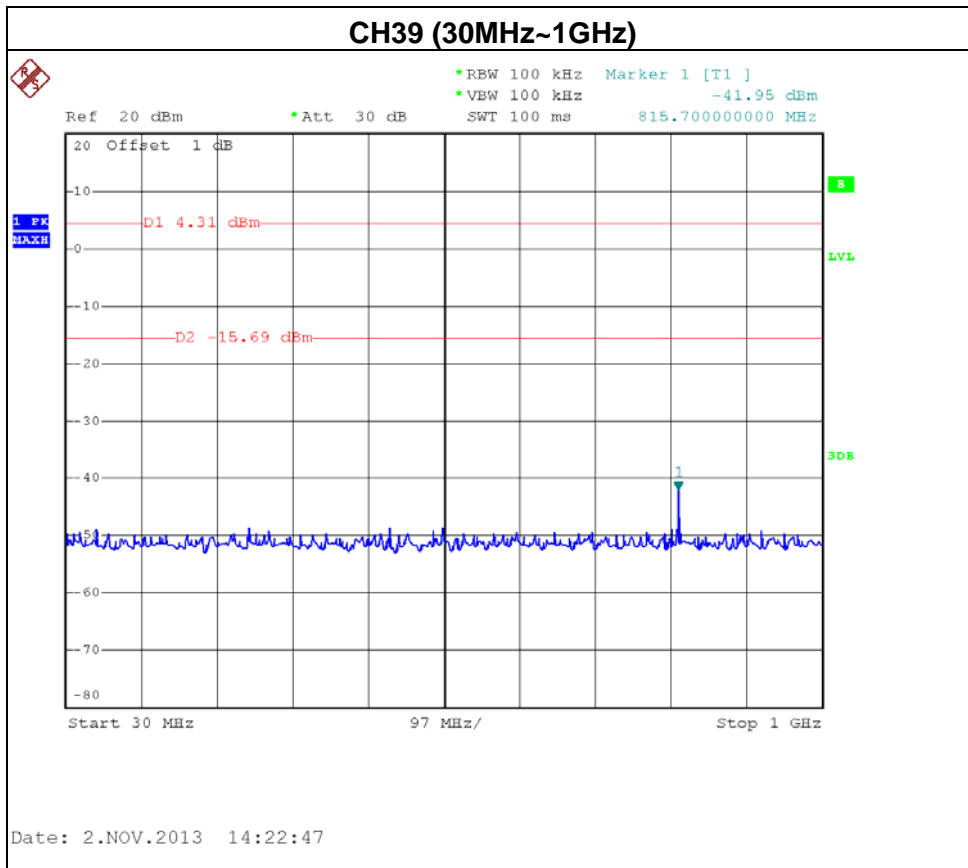

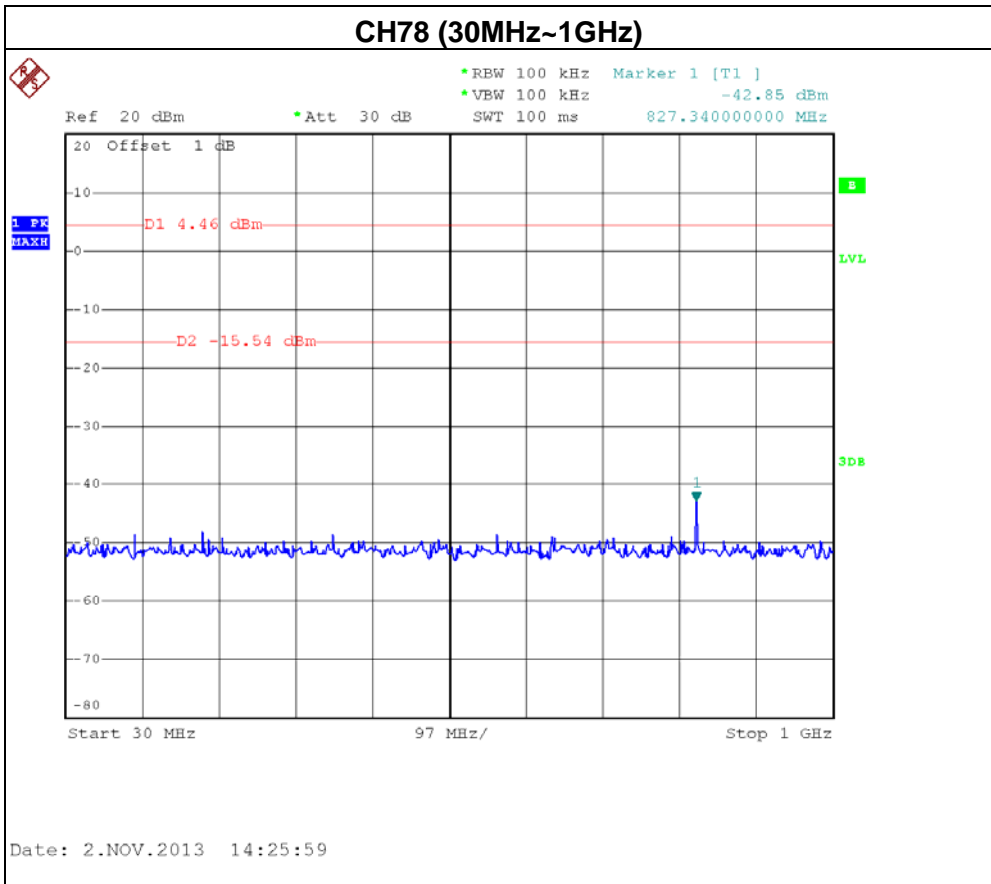

Date: 2.NOV.2013 14:25:59

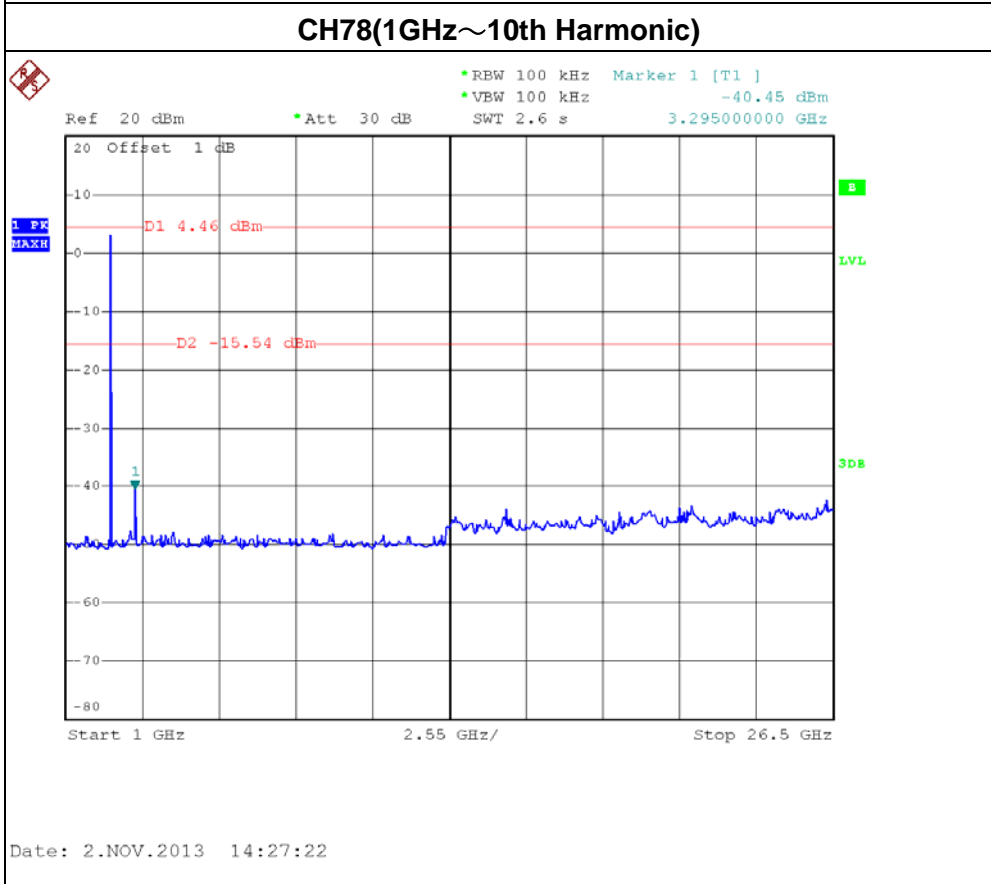

Date: 2.NOV.2013 14:27:22



11. EUT TEST PHOTO

**Radiated Measurement Photos
30M~1000MHz**

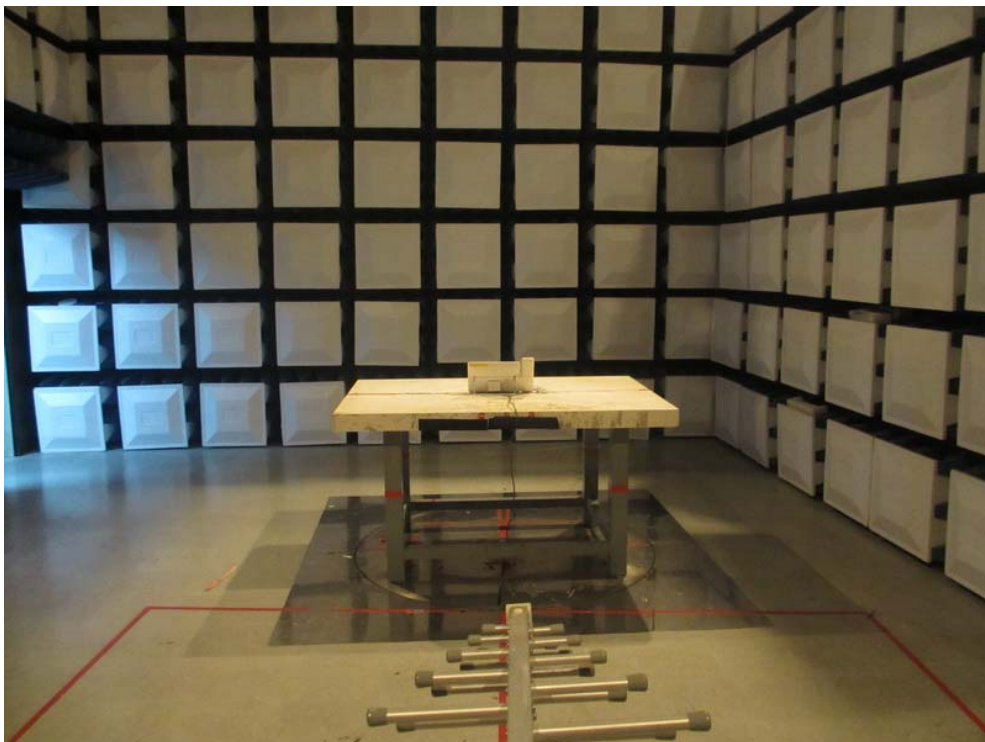
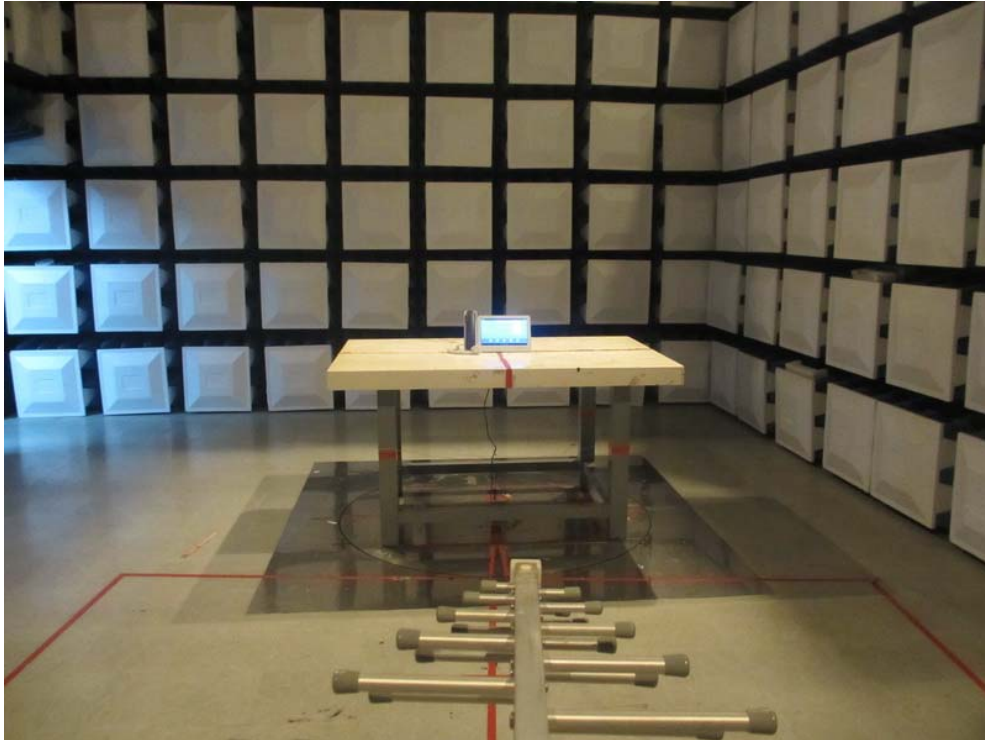



**Radiated Measurement Photos
Above 1000MHz**

