



FCC TEST REPORT

REPORT NO.: RF921118R02

MODEL NO.: T60H786

RECEIVED: Nov. 18, 2003

TESTED: Nov. 27 to Dec. 02, 2003

APPLICANT: AMBIT Microsystems Corporation

ADDRESS: 5F-1,5 Hsin-An Road Hsinchu, Science-Based
Industrial Park Taiwan, R.O.C.

ISSUED BY: Advance Data Technology Corporation

LAB LOCATION: No. 81-1, Lu Liao Keng, 9 Ling, Wu Lung Tsuen,
Chiung Lin Hsiang, Hsin Chu Hsien,
Taiwan, R.O.C.

This test report consists of 73 pages in total. It may be duplicated completely for legal use with the approval of the applicant. It should not be reproduced except in full, without the written approval of our laboratory. The client should not use it to claim product endorsement by CNLA, NVLAP or any government agencies. The test results in the report only apply to the tested sample.



0536
ILAC MRA



Lab Code: 200376-0



Table of Contents

1	CERTIFICATION.....	4
2	SUMMARY OF TEST RESULTS.....	5
3	GENERAL INFORMATION	6
3.1	GENERAL DESCRIPTION OF EUT.....	6
3.2	DESCRIPTION OF TEST MODES.....	7
3.3	GENERAL DESCRIPTION OF APPLIED STANDARDS	7
3.4	DESCRIPTION OF SUPPORT UNITS.....	8
4	TEST TYPES AND RESULTS	9
4.1	CONDUCTED EMISSION MEASUREMENT.....	9
4.1.1	LIMITS OF CONDUCTED EMISSION MEASUREMENT.....	9
4.1.2	TEST INSTRUMENTS	9
4.1.3	TEST SETUP	10
4.1.4	EUT OPERATING CONDITIONS	11
4.1.5	TEST RESULTS.....	12
4.2	Radiated Emission Measurement.....	14
4.2.1	LIMITS OF RADIATED EMISSION MEASUREMENT.....	14
4.2.2	TEST INSTRUMENTS	15
4.2.3	TEST PROCEDURES	16
4.2.4	TEST SETUP	17
4.2.5	EUT OPERATING CONDITIONS	17
4.2.6	TEST RESULTS (i)- Antenna 2.....	18
4.2.7	TEST RESULTS (I)- Antenna 2, DSSS.....	19
4.2.8	TEST RESULTS (I)- Antenna 2, OFDM.....	22
4.2.9	TEST RESULTS (ii)- Antenna 3	25
4.2.10	TEST RESULTS (II)- Antenna 3, DSSS.....	26
4.2.11	TEST RESULTS (II)- Antenna 3, OFDM.....	29
4.2.12	TEST RESULTS (iii)- Antenna 4	32
4.2.13	TEST RESULTS (III)- Antenna 4, DSSS.....	33
4.2.14	TEST RESULTS (III)- Antenna 4, OFDM.....	36
4.3	6dB BANDWIDTH MEASUREMENT	39
4.3.1	LIMITS OF 6dB BANDWIDTH MEASUREMENT.....	39
4.3.2	TEST INSTRUMENTS	39
4.3.3	TEST PROCEDURE	40



4.3.4	TEST SETUP	40
4.3.5	EUT OPERATING CONDITIONS	40
4.3.6	TEST RESULTS-DSSS	41
4.3.7	TEST RESULTS-OFDM	45
4.4	MAXIMUM PEAK OUTPUT POWER	49
4.4.1	LIMITS OF MAXIMUM PEAK OUTPUT POWER MEASUREMENT	49
4.4.2	TEST INSTRUMENTS	49
4.4.3	TEST PROCEDURES	50
4.4.4	TEST SETUP	50
4.4.5	EUT OPERATING CONDITIONS	50
4.4.6	TEST RESULTS-DSSS	51
4.4.7	TEST RESULTS-OFDM	51
4.5	POWER SPECTRAL DENSITY MEASUREMENT	52
4.5.1	LIMITS OF POWER SPECTRAL DENSITY MEASUREMENT.....	52
4.5.2	TEST INSTRUMENTS	52
4.5.3	TEST PROCEDURE	53
4.5.4	TEST SETUP	53
4.5.5	EUT OPERATING CONDITIONS	53
4.5.6	TEST RESULTS-DSSS	54
4.5.7	TEST RESULTS-OFDM	58
4.6	BAND EDGES MEASUREMENT.....	62
4.6.1	LIMITS OF BAND EDGES MEASUREMENT.....	62
4.6.2	TEST INSTRUMENTS	62
4.6.3	TEST PROCEDURE	62
4.6.4	EUT OPERATING CONDITION.....	62
4.6.5	TEST RESULTS - DSSS.....	63
4.6.6	TEST RESULTS-OFDM	66
4.7	ANTENNA REQUIREMENT.....	69
4.7.1	STANDARD APPLICABLE.....	69
4.7.2	ANTENNA CONNECTED CONSTRUCTION	69
5	PHOTOGRAPHS OF THE TEST CONFIGURATION.....	70
6	INFORMATION ON THE TESTING LABORATORIES.....	73



1 CERTIFICATION

PRODUCT : 802.11b/g MiniPCI module
BRAND NAME : AMBIT
MODEL NO. : T60H786
APPLICANT : AMBIT Microsystems Corporation
STANDARDS : 47 CFR Part 15, Subpart C (Section 15.247),
ANSI C63.4-1992

We, **Advance Data Technology Corporation**, hereby certify that one sample of the designation has been tested in our facility from Nov. 27 to Dec. 02, 2003. The test record, data evaluation and Equipment Under Test (EUT) configurations represented herein are true and accurate accounts of the measurements of the sample's EMC characteristics under the conditions herein specified.

PREPARED BY: Carol Liao , **DATE:** Dec. 03, 2003
(Carol Liao)

APPROVED BY: Eric Lin , **DATE:** Dec. 03, 2003
(Eric Lin, Manager)



2 SUMMARY OF TEST RESULTS

The EUT has been tested according to the following specifications:

APPLIED STANDARD: 47 CFR Part 15, Subpart C			
Standard Section	Test Type and Limit	Result	REMARK
15.207	AC Power Conducted Emission Limit: 48dBuV	PASS	Meet the requirement of limit Minimum passing margin is -21.50 dBuV at 1.255 MHz
15.247(a)(2)	Spectrum Bandwidth of a Direct Sequence Spread Spectrum System Limit: min. 500kHz	PASS	Meet the requirement of limit
15.247(b)	Maximum Peak Output Power Limit: max. 30dBm	PASS	Meet the requirement of limit
15.247(c)	Transmitter Radiated Emissions Limit: Table 15.209	PASS	Meet the requirement of limit Minimum passing margin is -1.1 dBuV at 2483.50MHz
15.247(d)	Power Spectral Density Limit: max. 8dBm	PASS	Meet the requirement of limit
15.247(c)	Band Edge Measurement Limit: 20 dB less than the peak value of fundamental frequency	PASS	Meet the requirement of limit



3 GENERAL INFORMATION

3.1 GENERAL DESCRIPTION OF EUT

PRODUCT	802.11b/g MiniPCI module
MODEL NO.	T60H786
POWER SUPPLY	3.3VDC from host equipment
MODULATION TYPE	CCK, OFDM, DBPSK, DQPSK
RADIO TECHNOLOGY	DSSS, OFDM
TRANSFER RATE	1/2/5.5/6/9/11/12/18/24/36/48/54Mbps
FREQUENCY RANGE	2412MHz ~ 2462MHz
NUMBER OF CHANNEL	11
OUTPUT POWER	23dBm
ANTENNA TYPE	Dipole Antenna and Monopole Antenna
DATA CABLE	NA
I/O PORTS	NA
ASSOCIATED DEVICES	NA

NOTE:

1. There are five types of antennas provided to this EUT, please refer to the following table:

No.	Model No.	Gain (dBi)	Antenna Type / Connector
1	IRX-2900-EVT	-1.54	Monopole antenna / with HRS connector
2	R-0323-130	0.44	Dipole antenna / with HRS connector
3	1-754-292	-2.1	Monopole antenna / with HRS connector
4	1-754-272	0.98	Monopole antenna / with HRS connector
5	1-754-288	-2.6	Monopole antenna / with HRS connector

From the above antennas, antenna 2 (R-0323-130), antenna 3 (1-754-292) and antenna 4 (1-754-272) were selected as representative antennas for test. Their data were recorded in this report.

- The EUT operates in the 2.4GHz frequency spectrum with throughput of up to 54Mbps.
- The EUT complies with IEEE 802.11g draft standards, and backwards compatible with IEEE 802.11b products.
- The firmware for this device allows it to operate only on channel 1 through 11 in the United States.
- For a more detailed features description, please refer to the manufacturer's specifications or User's Manual.



3.2 DESCRIPTION OF TEST MODES

Eleven channels are provided in this EUT.

Channel	Frequency	Channel	Frequency
1	2412 MHz	7	2442 MHz
2	2417 MHz	8	2447 MHz
3	2422 MHz	9	2452 MHz
4	2427 MHz	10	2457 MHz
5	2432 MHz	11	2462 MHz
6	2437 MHz		

NOTE:

1. Below 1 GHz, the channel 1, 6, and 11 were pre-tested in chamber. The channel 11, worst case one, was chosen for final test.
2. Above 1 GHz, the channel 1, 6, and 11 were tested individually.
3. Test result was mentioned on section 3.1.
4. Transfer rate, 11Mbps with CCK technique and 6Mbps with OFDM technique, the worst case, were chosen for final test.

3.3 GENERAL DESCRIPTION OF APPLIED STANDARDS

The EUT is an 802.11b/g MiniPCI module. According to the specifications of the manufacturer, it must comply with the requirements of the following standards:

47 CFR Part 15, Subpart C. (15.247)
ANSI C63.4 : 1992

All tests have been performed and recorded as per the above standards.

NOTE: The EUT is also considered as a kind of computer peripheral, because the connection to computer is necessary for typical use. It has been verified to comply with the requirements of 47 CFR Part 15, Subpart B, Class B (DoC). The test report has been issued separately.



3.4 DESCRIPTION OF SUPPORT UNITS

The EUT has been tested as an independent unit together with other necessary accessories or support units. The following support units or accessories were used to form a representative test configuration during the tests.

No.	Product	Brand	Model No.	Serial No.	FCC ID
1	NOTEBOOK COMPUTER	IBM	IBM ThinkPad X31	X3x	NA
2	Matrix Printer	EPSON	LQ-300+	DCGY017079	FCC DoC

No.	Signal cable description
1	NA
2	1.8 m braid shielded wire, terminated with DB25 and Centronics connector via metallic frame, w/o core.

Note: 1. All power cords of the above support units are unshielded (1.8m).

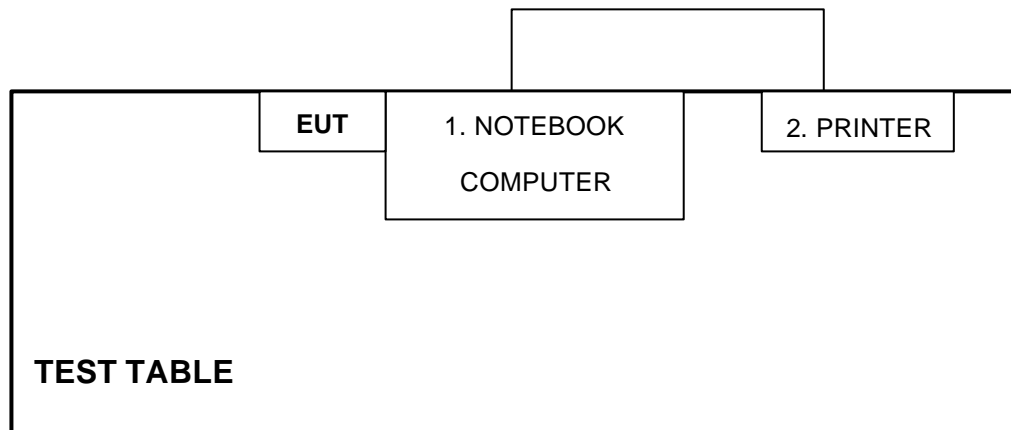

NOTE: 1. Please refer to the photos of test configuration in Item 5 also.



4 TEST TYPES AND RESULTS

4.1 CONDUCTED EMISSION MEASUREMENT

4.1.1 LIMITS OF CONDUCTED EMISSION MEASUREMENT

FREQUENCY OF EMISSION (MHz)	CONDUCTED LIMIT (dB μ V)	
	Quasi-peak	Average
0.15-0.5	66 to 56	56 to 46
0.5-5	56	46
5-30	60	50

NOTE

1. The lower limit shall apply at the transition frequencies.
2. All emanations from a class B digital device or system, including any network of conductors and apparatus connected thereto, shall not exceed the level of field strengths specified above.

4.1.2 TEST INSTRUMENTS

DESCRIPTION & MANUFACTURER	MODEL NO.	SERIAL NO.	CALIBRATED UNTIL
ROHDE & SCHWARZ Test Receiver	ESCS 30	847124/029	Nov. 17, 2004
ROHDE & SCHWARZ LISN (for EUT)	ESHS-Z5	848773/004	Nov. 13, 2004
KYORITSU LISN (for peripheral)	KNW-407	8/1395/12	Jul. 23, 2004
RF Cable (JETBAO)	RG233/U	Cable_CA_01	Jul. 03, 2004
Terminator(for KYORITSU)	50	3	Apr. 11, 2004
Software	Cond-V2e	NA	NA

- NOTE: 1. The calibration interval of the above test instruments is 12 months and the calibrations are traceable to NML/ROC and NIST/USA.
 2. The test was performed in ADT Shielded Room No. A.
 3. The VCCI Con A Registration No. is C-817.

3. TEST PROCEDURES

- The EUT was placed 0.4 meters from the conducting wall of the shielded room with EUT being connected to the power mains through a line impedance stabilization network (LISN). Other support units were connected to the power mains through another LISN. The two LISNs provide 50 ohm/ 50uH of coupling impedance for the measuring instrument.
- Both lines of the power mains connected to the EUT were checked for maximum conducted interference.
- The frequency range from 150 kHz to 30 MHz was searched. Emission levels over 10dB under the prescribed limits could not be reported

4.1.3 TEST SETUP

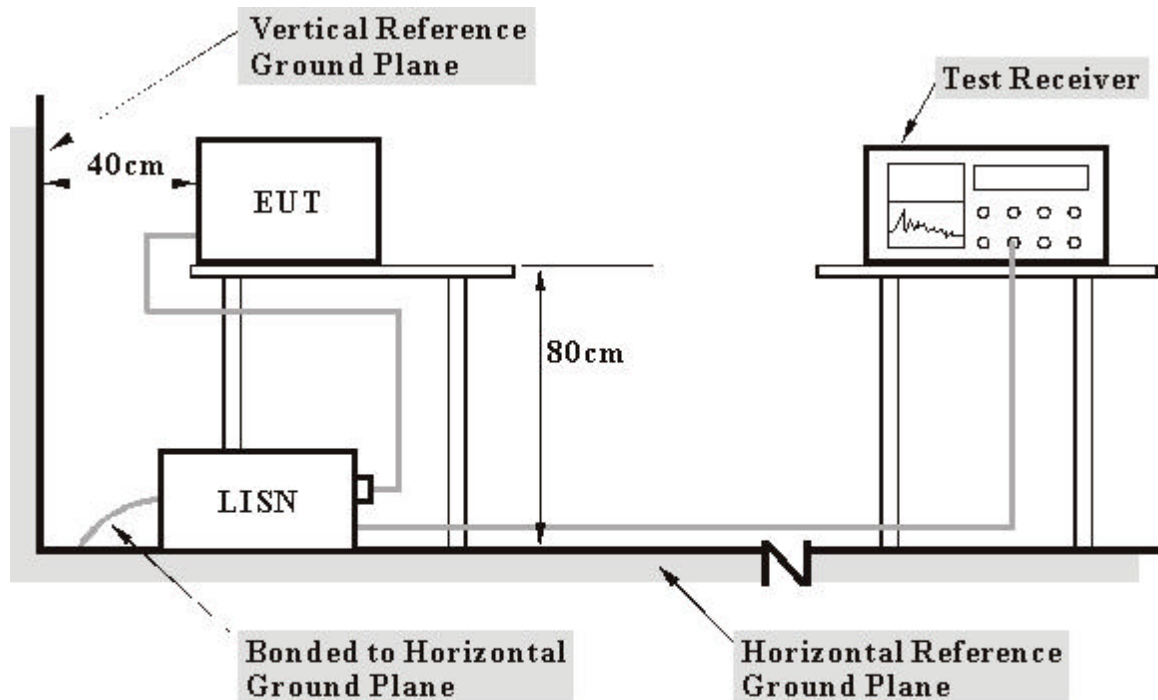

- Note:**
- Support units were connected to second LISN.
 - Both of LISNs (AMN) 80 cm from EUT and at the least 80 cm from other units and other metal planes support units.

For the actual test configuration, please refer to the related item – Photographs of the Test Configuration.



4.1.4 EUT OPERATING CONDITIONS

- a. Plug the EUT into the support unit 1 (Notebook computer) which placed on a testing table.
- b. The support unit 1 (Notebook computer) ran a test program to enable EUT under transmission condition continuously at specific channel frequency.
- c. Notebook computer sends "H" messages to printer, and the printer prints them on paper.



4.1.5 TEST RESULTS

EUT	802.11b/g MiniPCI module	MODEL	T60H786
MODE	Channel 11	6dB BANDWIDTH	9 kHz
INPUT POWER (SYSTEM)	120Vac, 60 Hz	PHASE	Line (L)
ENVIRONMENTAL CONDITIONS	25 deg. C, 50%RH, 974 hPa	TESTED BY	Eric Lee

No	Freq. [MHz]	Corr. Factor (dB)	Reading Value		Emission Level		Limit		Margin	
			[dB (uV)]		[dB (uV)]		[dB (uV)]		(dB)	
			Q.P.	AV.	Q.P.	AV.	Q.P.	AV.	Q.P.	AV.
1	0.170	0.20	34.37	-	34.57	-	64.98	54.98	-30.41	-
2	0.338	0.20	33.71	-	33.91	-	59.26	49.26	-25.35	-
3	0.420	0.20	32.62	-	32.82	-	57.46	47.46	-24.63	-
4	0.591	0.23	32.04	-	32.27	-	56.00	46.00	-23.73	-
5	5.821	0.52	31.46	-	31.98	-	60.00	50.00	-28.02	-
6	9.447	0.76	28.65	-	29.41	-	60.00	50.00	-30.59	-

- NOTES:** (1) "**": Undetectable
 (2) Q.P. and AV. are abbreviations of quasi-peak and average.
 (3) "-": The Quasi-peak reading value also meets an average limit, thus measurement with the average detector is unnecessary.
 (4) The emission levels of other frequencies were very low against the limit.
 (5) Correction Factor = Insertion loss + Cable loss
 (6) Margin value = Emission level - Limit value

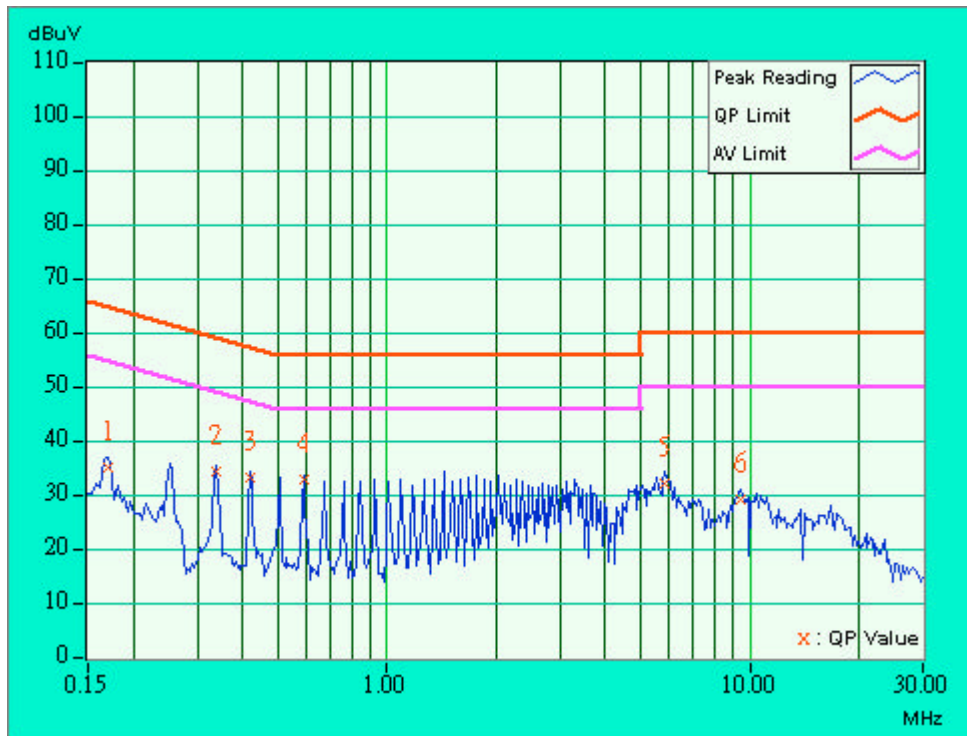



EUT	802.11b/g MiniPCI module	MODEL	T60H786
MODE	Channel 11	6dB BANDWIDTH	9 kHz
INPUT POWER (SYSTEM)	120Vac, 60 Hz	PHASE	Neutral (N)
ENVIRONMENTAL CONDITIONS	25 deg. C, 50%RH, 974 hPa	TESTED BY	Eric Lee

No	Freq. [MHz]	Corr. Factor (dB)	Reading Value [dB (uV)]		Emission Level [dB (uV)]		Limit [dB (uV)]		Margin (dB)	
			Q.P.	AV.	Q.P.	AV.	Q.P.	AV.	Q.P.	AV.
			1	0.166	0.20	35.24	-	35.44	-	65.18
2	0.252	0.20	33.23	-	33.43	-	61.68	51.68	-28.25	-
3	0.418	0.20	32.37	-	32.57	-	57.49	47.49	-24.91	-
4	1.255	0.30	34.20	-	34.50	-	56.00	46.00	-21.50	-
5	5.686	0.48	34.81	-	35.29	-	60.00	50.00	-24.71	-
6	15.063	1.00	22.93	-	23.93	-	60.00	50.00	-36.07	-

- NOTES:**
- (1) "": Undetectable
 - (2) Q.P. and AV. are abbreviations of quasi-peak and average.
 - (3) "-": The Quasi-peak reading value also meets an average limit, thus measurement with the average detector is unnecessary.
 - (4) The emission levels of other frequencies were very low against the limit.
 - (5) Correction Factor = Insertion loss + Cable loss
 - (6) Margin value = Emission level - Limit value

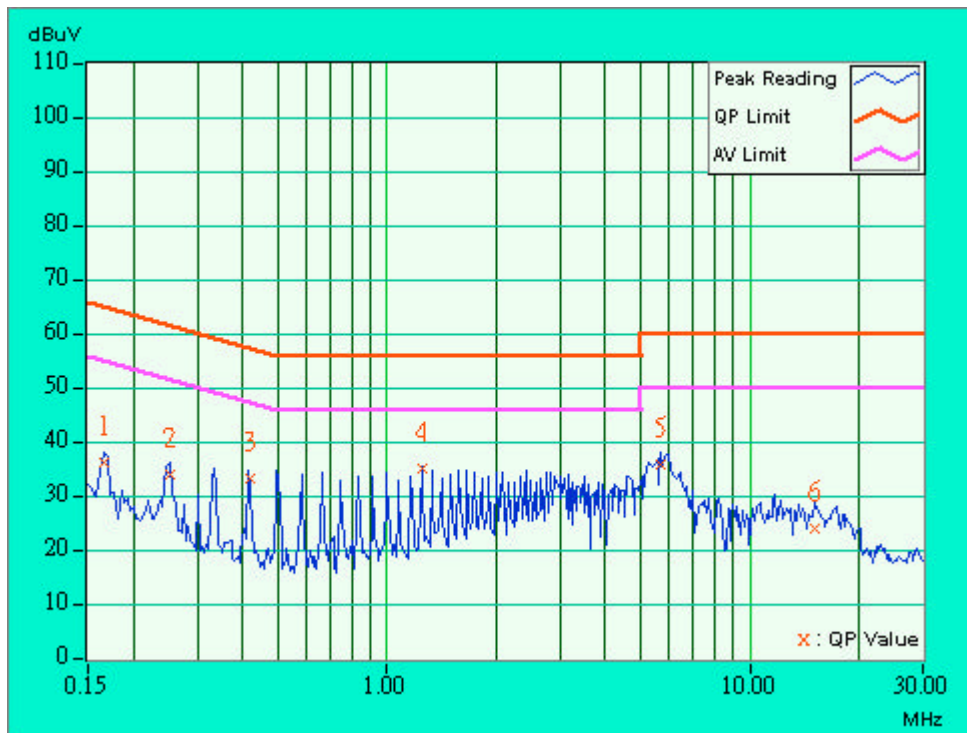



4.2 RADIATED EMISSION MEASUREMENT

4.2.1 LIMITS OF RADIATED EMISSION MEASUREMENT

Field strength limits are at the distance of 3 meters, emissions radiated outside of the specified bands, shall be according to the general radiated limits in 15.209 as following:

Frequencies (MHz)	Field Strength of Fundamental	
	uV/m	dBuV/m
30-88	100	40.0
88-216	150	43.5
216-960	200	46.0
Above 960	500	54.0

NOTE

1. The lower limit shall apply at the transition frequencies.
2. Emission level (dBuV/m) = 20 log Emission level (uV/m).
3. As shown in 15.35(b), for frequencies above 1000MHz, the field strength limits are based on average detector, however, the peak field strength of any emission shall not exceed the maximum permitted average limits, specified above by more than 20dB under any condition of modulation.



4.2.2 TEST INSTRUMENTS

DESCRIPTION & MANUFACTURER	MODEL NO.	SERIAL NO.	CALIBRATED UNTIL
HP Spectrum Analyzer	8590L	3829A02338	Sep. 10, 2004
*ADVANTEST Spectrum Analyzer	R3271A	85060311	May 21, 2004
CHASE RF Pre_Amplifier	CPA9232	1001	Mar. 02, 2004
*HP Pre_Amplifier	8449B	3008A01281	Nov. 27, 2004
*ROHDE & SCHWARZ Test Receiver	ESCS 30	100027	May 23, 2004
*CHASE Broadband Antenna	CBL6112B	2502	Jul. 31, 2004
*Schwarzbeck Horn_Antenna	BBHA9120-D1	D123	Jul. 31, 2004
SCHWARZBECK Tunable Dipole Antenna	UHAP	897	Mar. 07, 2005
SCHWARZBECK Tunable Dipole Antenna	VHAP	880	Mar. 07, 2005
*RF Switches	MP59B	M50867	Jul. 31, 2004
*RF Cable(JETBAO)	BELDN RG-214	Cable_OA_01	Jul. 31, 2004
*Software	AS60P8	NA	NA
*EMCO Antenna Tower	2075-2	9712-2124	NA
*EMCO Turn Table	2081-1.53	9712-2030	NA
*CORCOM AC Filter	MRI2030	107/108	NA

Note: 1. The calibration interval of the above test instruments is 12 months (36 months for Tunable Dipole Antenna) and the calibrations are traceable to NML/ROC and NIST/USA.

2. * = These equipment are used for the final measurement.
3. The horn antenna and HP preamplifier (model: 8449B) are used only for the measurement of emission frequency above 1GHz if tested.
4. The test was performed in ADT Open Site No. A.
5. The VCCI Site Registration No. is R-782.
6. The FCC Site Registration No. is 91097.
7. The CANADA Site Registration No. is IC 3789-C.



4.2.3 TEST PROCEDURES

- a. The EUT was placed on the top of a rotating table 0.8 meters above the ground at a 10 meter open area test site. The table was rotated 360 degrees to determine the position of the highest radiation.
- b. The EUT was set 3 meters away from the interference-receiving antenna, which was mounted on the top of a variable-height antenna tower.
- c. The antenna is a broadband antenna, and its height is varied from one meter to four meters above the ground to determine the maximum value of the field strength. Both horizontal and vertical polarizations of the antenna are set to make the measurement.
- d. For each suspected emission, the EUT was arranged to its worst case and then the antenna was tuned to heights from 1 meter to 4 meters and the rotatable table was turned from 0 degrees to 360 degrees to find the maximum reading.
- e. The test-receiver system was set to Peak Detect Function and Specified Bandwidth with Maximum Hold Mode.
- f. If the emission level of the EUT in peak mode was 10 dB lower than the limit specified, then testing could be stopped and the peak values of the EUT would be reported. Otherwise the emissions that did not have 10 dB margin would be re-tested one by one using peak, quasi-peak or average method as specified and then reported in a data sheet.

NOTE:

1. The resolution bandwidth and video bandwidth of test receiver/spectrum analyzer is 120kHz for Peak detection (PK) and Quasi-peak detection (QP) at frequency below 1GHz.
2. The resolution bandwidth and video bandwidth of test receiver/spectrum analyzer is 1 MHz for Peak detection at frequency above 1GHz.
3. The resolution bandwidth of test receiver/spectrum analyzer is 1 MHz and the video bandwidth is 300 Hz for Average detection (AV) at frequency above 1GHz.

4.2.4 TEST SETUP

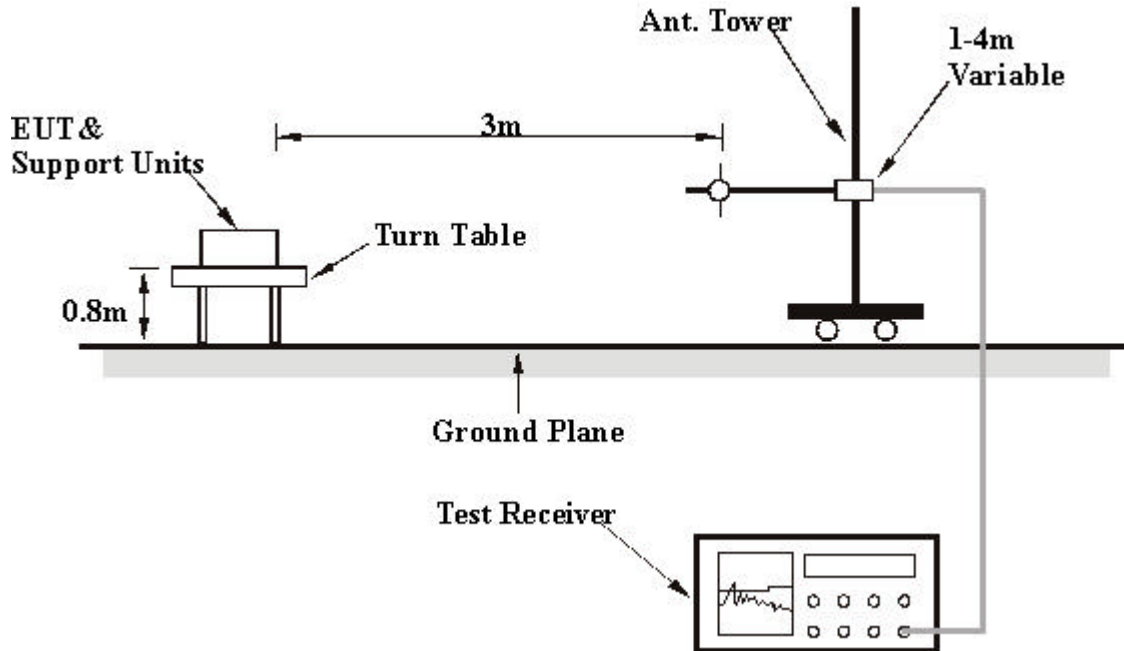

For the actual test configuration, please refer to the related item – Photographs of the Test Configuration.

4.2.5 EUT OPERATING CONDITIONS

Same as 4.1.5.



4.2.6 TEST RESULTS (I)- ANTENNA 2

EUT	802.11b/g MiniPCI module	MODEL	T60H786
MODE	Channel 11	FREQUENCY RANGE	30-1000 MHz
INPUT POWER (SYSTEM)	120Vac, 60 Hz	DETECTOR FUNCTION	Quasi-Peak
ENVIRONMENTAL CONDITIONS	20 deg. C, 60 % RH, 974 hPa	TESTED BY	Eric Lee

ANTENNA POLARITY & TEST DISTANCE: HORIZONTAL AT 3 M

No.	Freq. (MHz)	Emission Level (dBuV/m)	Limit (dBuV/m)	Margin (dB)	Antenna Height (m)	Table Angle (Degree)	Raw Value (dBuV)	Correction Factor (dB/m)
1	65.17	23.00 QP	40.00	-17.00	1.13 H	55	15.60	7.40
2	200.00	28.10 QP	43.50	-15.40	1.48 H	300	17.00	11.20
3	233.70	33.30 QP	46.00	-12.70	1.07 H	61	20.90	12.40
4	266.49	37.00 QP	46.00	-9.00	1.40 H	227	22.00	15.00
5	299.93	43.10 QP	46.00	-2.90	1.50 H	126	27.50	15.60
6	399.06	34.30 QP	46.00	-11.70	1.00 H	190	15.50	18.80
7	499.46	35.20 QP	46.00	-10.80	1.00 H	177	14.00	21.30
8	666.01	41.80 QP	46.00	-4.20	1.08 H	136	18.90	22.90
9	770.79	39.00 QP	46.00	-7.00	1.60 H	311	15.00	24.10
10	799.79	41.10 QP	46.00	-4.90	1.16 H	328	17.00	24.20

ANTENNA POLARITY & TEST DISTANCE: VERTICAL AT 3 M

No.	Freq. (MHz)	Emission Level (dBuV/m)	Limit (dBuV/m)	Margin (dB)	Antenna Height (m)	Table Angle (Degree)	Raw Value (dBuV)	Correction Factor (dB/m)
1	66.59	26.70 QP	40.00	-13.30	1.54 V	97	19.60	7.10
2	199.78	26.40 QP	43.50	-17.10	1.29 V	55	15.30	11.10
3	240.00	32.50 QP	46.00	-13.50	1.00 V	150	19.20	13.30
4	299.94	43.90 QP	46.00	-2.10	2.11 V	324	28.30	15.60
5	400.01	37.20 QP	46.00	-8.80	1.07 V	168	18.40	18.80
6	500.26	35.10 QP	46.00	-10.90	1.68 V	178	13.80	21.30
7	535.26	40.80 QP	46.00	-5.20	1.12 V	278	18.70	22.10
8	600.00	31.00 QP	46.00	-15.00	1.11 V	308	8.80	22.20
9	666.03	42.30 QP	46.00	-3.70	1.03 V	38	19.40	22.90
10	799.77	39.00 QP	46.00	-7.00	1.54 V	152	14.80	24.20

- REMARKS:**
1. Emission level(dBuV/m)=Raw Value(dBuV) + Correction Factor(dB)
 2. Correction Factor(dB/m) = Antenna Factor (dB/m) + Cable Factor (dB)
 3. The other emission levels were very low against the limit.
 4. Margin value = Emission level – Limit value.



4.2.7 TEST RESULTS (I)- Antenna 2, DSSS

EUT	802.11b/g MiniPCI module	MODEL	T60H786
MODE	Channel 1	FREQUENCY RANGE	1000 ~ 25000 MHz
INPUT POWER (SYSTEM)	120Vac, 60 Hz	DETECTOR FUNCTION	Peak(PK) Average(AV)
ENVIRONMENTAL CONDITIONS	20 deg. C, 60 % RH, 974 hPa	TESTED BY	Eric Lee

ANTENNA POLARITY & TEST DISTANCE: HORIZONTAL AT 3 M

No.	Freq. (MHz)	Emission Level (dBuV/m)	Limit (dBuV/m)	Margin (dB)	Antenna Height (m)	Table Angle (Degree)	Raw Value (dBuV)	Correction Factor (dB/m)
1	2360.00	49.00 PK	74.00	-25.00	1.02 H	54	19.30	29.70
2	2386.00	50.80 PK	74.00	-23.20	1.47 H	45	21.00	29.80
3	2390.00	49.80 PK	74.00	-24.20	1.11 H	47	20.00	29.80
4	*2412.00	106.10 PK			1.54 H	87	76.20	29.90
4	*2412.00	98.80 AV			1.54 H	87	68.90	29.90
5	4824.00	53.80 PK	74.00	-20.20	1.02 H	87	17.60	36.20
5	4824.00	45.80 AV	54.00	-8.20	1.02 H	87	9.50	36.20
6	7236.00	56.30 PK	74.00	-17.70	1.15 H	326	14.70	41.70
6	7236.00	47.70 AV	54.00	-6.30	1.15 H	326	6.00	41.70
7	9648.00	55.50 PK	74.00	-18.50	1.25 H	87	10.60	44.90
7	9648.00	45.10 AV	54.00	-8.90	1.25 H	87	0.20	44.90

ANTENNA POLARITY & TEST DISTANCE: VERTICAL AT 3 M

No.	Freq. (MHz)	Emission Level (dBuV/m)	Limit (dBuV/m)	Margin (dB)	Antenna Height (m)	Table Angle (Degree)	Raw Value (dBuV)	Correction Factor (dB/m)
1	2360.00	50.00 PK	74.00	-24.00	1.63 V	25	20.40	29.70
2	2386.00	50.80 PK	74.00	-23.20	1.59 V	353	21.00	29.80
3	2390.00	52.20 PK	74.00	-21.80	1.57 V	359	22.40	29.80
3	2390.00	44.00 AV	54.00	-10.00	1.57 V	359	14.20	29.80
4	*2412.00	107.40 PK			1.05 V	298	77.50	29.90
4	*2412.00	100.10 AV			1.05 V	298	70.20	29.90
5	4824.00	58.50 PK	74.00	-15.50	1.01 V	352	22.30	36.20
5	4824.00	49.00 AV	54.00	-5.00	1.01 V	352	12.80	36.20
6	7236.00	61.20 PK	74.00	-12.80	1.50 V	99	19.60	41.70
6	7236.00	51.50 AV	54.00	-2.50	1.50 V	99	9.80	41.70
7	9648.00	58.20 PK	74.00	-15.80	1.39 V	45	13.30	44.90
7	9648.00	47.80 AV	54.00	-6.20	1.39 V	45	2.90	44.90

- REMARKS:**
1. Emission level(dBuV/m)=Raw Value(dBuV) + Correction Factor(dB)
 2. Correction Factor(dB/m) = Antenna Factor (dB/m) + Cable Factor (dB)
 3. The other emission levels were very low against the limit.
 4. Margin value = Emission level – Limit value.
 5. The limit value is defined as per 15.247
 6. “ * “ : Fundamental frequency



EUT	802.11b/g MiniPCI module	MODEL	T60H786
MODE	Channel 6	FREQUENCY RANGE	1000 ~ 25000 MHz
INPUT POWER (SYSTEM)	120Vac, 60 Hz	DETECTOR FUNCTION	Peak(PK) Average (AV)
ENVIRONMENTAL CONDITIONS	20 deg. C, 60 % RH, 974 hPa	TESTED BY	Eric Lee

ANTENNA POLARITY & TEST DISTANCE: HORIZONTAL AT 3 M

No.	Freq. (MHz)	Emission Level (dBuV/m)	Limit (dBuV/m)	Margin (dB)	Antenna Height (m)	Table Angle (Degree)	Raw Value (dBuV)	Correction Factor (dB/m)
1	*2437.00	106.80 PK			1.54 H	24	76.80	30.00
1	*2437.00	98.70 AV			1.54 H	24	68.70	30.00
2	4874.00	55.90 PK	74.00	-18.10	1.02 H	65	19.40	36.50
2	4874.00	45.90 AV	54.00	-8.10	1.02 H	65	9.50	36.50
3	7311.00	56.40 PK	74.00	-17.60	1.52 H	24	14.70	41.80
3	7311.00	47.70 AV	54.00	-6.30	1.52 H	24	5.90	41.80
4	9748.00	53.60 PK	74.00	-20.40	1.02 H	79	8.90	44.60
4	9748.00	42.80 AV	54.00	-11.20	1.02 H	79	-1.90	44.60

ANTENNA POLARITY & TEST DISTANCE: VERTICAL AT 3 M

No.	Freq. (MHz)	Emission Level (dBuV/m)	Limit (dBuV/m)	Margin (dB)	Antenna Height (m)	Table Angle (Degree)	Raw Value (dBuV)	Correction Factor (dB/m)
1	*2437.00	107.60 PK			1.03 V	299	77.60	30.00
1	*2437.00	101.00 AV			1.03 V	299	71.00	30.00
2	4874.00	58.90 PK	74.00	-15.10	1.02 V	353	22.40	36.50
2	4874.00	48.90 AV	54.00	-5.10	1.02 V	353	12.50	36.50
3	7311.00	59.60 PK	74.00	-14.40	1.03 V	69	17.90	41.80
3	7311.00	52.70 AV	54.00	-1.30	1.03 V	69	10.90	41.80
4	9748.00	58.20 PK	74.00	-15.80	1.80 V	33	13.60	44.60
4	9748.00	47.80 AV	54.00	-6.20	1.80 V	33	3.20	44.60

- REMARKS:**
1. Emission level(dBuV/m)=Raw Value(dBuV) + Correction Factor(dB)
 2. Correction Factor(dB/m) = Antenna Factor (dB/m) + Cable Factor (dB)
 3. The other emission levels were very low against the limit.
 4. Margin value = Emission level – Limit value.
 5. The limit value is defined as per 15.247
 6. “ * “ : Fundamental frequency



EUT	802.11b/g MiniPCI module	MODEL	T60H786
MODE	Channel 11	FREQUENCY RANGE	1000 ~ 25000 MHz
INPUT POWER (SYSTEM)	120Vac, 60 Hz	DETECTOR FUNCTION	Peak(PK) Average (AV)
ENVIRONMENTAL CONDITIONS	20 deg. C, 60 % RH, 974 hPa	TESTED BY	Eric Lee

ANTENNA POLARITY & TEST DISTANCE: HORIZONTAL AT 3 M

No.	Freq. (MHz)	Emission Level (dBuV/m)	Limit (dBuV/m)	Margin (dB)	Antenna Height (m)	Table Angle (Degree)	Raw Value (dBuV)	Correction Factor (dB/m)
1	*2462.00	105.10 PK			1.02 H	47	75.00	30.10
1	*2462.00	97.60 AV			1.02 H	47	67.60	30.10
2	2483.50	50.50 PK	74.00	-23.50	1.23 H	69	20.40	30.10
3	4924.00	55.20 PK	74.00	-18.80	1.02 H	69	18.50	36.70
3	4924.00	46.20 AV	54.00	-7.80	1.02 H	69	9.50	36.70
4	7386.00	58.20 PK	74.00	-15.80	1.71 H	54	16.40	41.80
4	7386.00	48.30 AV	54.00	-5.70	1.71 H	54	6.50	41.80
5	9848.00	53.20 PK	74.00	-20.80	1.02 H	78	8.90	44.40
5	9848.00	44.30 AV	54.00	-9.70	1.02 H	78	-0.10	44.40

ANTENNA POLARITY & TEST DISTANCE: VERTICAL AT 3 M

No.	Freq. (MHz)	Emission Level (dBuV/m)	Limit (dBuV/m)	Margin (dB)	Antenna Height (m)	Table Angle (Degree)	Raw Value (dBuV)	Correction Factor (dB/m)
1	*2462.00	106.60 PK			1.09 V	301	76.50	30.10
1	*2462.00	99.90 AV			1.09 V	301	69.90	30.10
2	2483.50	52.40 PK	74.00	-21.60	1.45 V	24	22.20	30.10
2	2483.50	44.40 AV	54.00	-9.60	1.45 V	24	14.30	30.10
3	4924.00	58.00 PK	74.00	-16.00	1.52 V	356	21.30	36.70
3	4924.00	50.50 AV	54.00	-3.50	1.52 V	356	13.90	36.70
4	7386.00	60.60 PK	74.00	-13.40	1.32 V	254	18.80	41.80
4	7386.00	52.20 AV	54.00	-1.80	1.32 V	254	10.30	41.80
5	9848.00	56.20 PK	74.00	-17.80	1.52 V	38	11.80	44.40
5	9848.00	47.70 AV	54.00	-6.30	1.52 V	38	3.30	44.40

- REMARKS:**
1. Emission level(dBuV/m)=Raw Value(dBuV) + Correction Factor(dB)
 2. Correction Factor(dB/m) = Antenna Factor (dB/m) + Cable Factor (dB)
 3. The other emission levels were very low against the limit.
 4. Margin value = Emission level – Limit value.
 5. The limit value is defined as per 15.247
 6. “ * “ : Fundamental frequency



4.2.8 TEST RESULTS (I)- Antenna 2, OFDM

EUT	802.11b/g MiniPCI module	MODEL	T60H786
MODE	Channel 1	FREQUENCY RANGE	1000 ~ 25000 MHz
INPUT POWER (SYSTEM)	120Vac, 60 Hz	DETECTOR FUNCTION	Peak(PK) Average(AV)
ENVIRONMENTAL CONDITIONS	20 deg. C, 60 % RH, 974 hPa	TESTED BY	Eric Lee

ANTENNA POLARITY & TEST DISTANCE: HORIZONTAL AT 3 M

No.	Freq. (MHz)	Emission Level (dBuV/m)	Limit (dBuV/m)	Margin (dB)	Antenna Height (m)	Table Angle (Degree)	Raw Value (dBuV)	Correction Factor (dB/m)
1	2360.00	56.00 PK	74.00	-18.00	1.02 H	69	26.30	29.70
1	2360.00	46.90 AV	54.00	-7.10	1.02 H	69	17.30	29.70
2	2390.00	56.80 PK	74.00	-17.20	1.11 H	54	27.00	29.80
2	2390.00	49.00 AV	54.00	-5.00	1.11 H	54	19.20	29.80
3	*2412.00	101.90 PK			1.02 H	54	72.00	29.90
3	*2412.00	93.10 AV			1.02 H	54	63.20	29.90
4	4824.00	58.80 PK	74.00	-15.20	1.23 H	62	22.50	36.20
4	4824.00	44.80 AV	54.00	-9.20	1.23 H	62	8.60	36.20
5	7236.00	54.10 PK	74.00	-19.90	1.98 H	65	12.50	41.70
5	7236.00	40.00 AV	54.00	-14.00	1.98 H	65	-1.70	41.70
6	9648.00	54.90 PK	74.00	-19.10	1.53 H	252	10.00	44.90
6	9648.00	42.20 AV	54.00	-11.80	1.53 H	252	-2.70	44.90

ANTENNA POLARITY & TEST DISTANCE: VERTICAL AT 3 M

No.	Freq. (MHz)	Emission Level (dBuV/m)	Limit (dBuV/m)	Margin (dB)	Antenna Height (m)	Table Angle (Degree)	Raw Value (dBuV)	Correction Factor (dB/m)
1	2360.00	56.90 PK	74.00	-17.10	1.54 V	241	27.30	29.70
1	2360.00	49.40 AV	54.00	-4.60	1.54 V	241	19.70	29.70
2	2390.00	59.20 PK	74.00	-14.80	1.52 V	4	29.40	29.80
2	2390.00	51.10 AV	54.00	-2.90	1.52 V	4	21.30	29.80
3	*2412.00	104.60 PK			1.32 V	225	74.70	29.90
3	*2412.00	95.80 AV			1.32 V	225	65.90	29.90
4	4824.00	61.70 PK	74.00	-12.30	1.20 V	38	25.50	36.20
4	4824.00	48.30 AV	54.00	-5.70	1.20 V	38	12.10	36.20
5	7236.00	57.60 PK	74.00	-16.40	1.03 V	65	16.00	41.70
5	7236.00	44.30 AV	54.00	-9.70	1.03 V	65	2.60	41.70
6	9648.00	56.50 PK	74.00	-17.50	1.31 V	151	11.60	44.90
6	9648.00	43.70 AV	54.00	-10.30	1.31 V	151	-1.20	44.90

- REMARKS:**
1. Emission level(dBuV/m)=Raw Value(dBuV) + Correction Factor(dB)
 2. Correction Factor(dB/m) = Antenna Factor (dB/m) + Cable Factor (dB)
 3. The other emission levels were very low against the limit.
 4. Margin value = Emission level – Limit value.
 5. The limit value is defined as per 15.247
 6. " * " : Fundamental frequency



EUT	802.11b/g MiniPCI module	MODEL	T60H786
MODE	Channel 6	FREQUENCY RANGE	1000 ~ 25000 MHz
INPUT POWER (SYSTEM)	120Vac, 60 Hz	DETECTOR FUNCTION	Peak(PK) Average (AV)
ENVIRONMENTAL CONDITIONS	20 deg. C, 60 % RH, 974 hPa	TESTED BY	Eric Lee

ANTENNA POLARITY & TEST DISTANCE: HORIZONTAL AT 3 M

No.	Freq. (MHz)	Emission Level (dBuV/m)	Limit (dBuV/m)	Margin (dB)	Antenna Height (m)	Table Angle (Degree)	Raw Value (dBuV)	Correction Factor (dB/m)
1	*2437.00	105.00 PK			1.47 H	54	75.00	30.00
1	*2437.00	95.80 AV			1.47 H	54	65.90	30.00
2	4874.00	60.20 PK	74.00	-13.80	1.57 H	8	23.80	36.50
2	4874.00	48.00 AV	54.00	-6.00	1.57 H	8	11.50	36.50
3	7311.00	60.40 PK	74.00	-13.60	1.85 H	63	18.70	41.80
3	7311.00	48.70 AV	54.00	-5.30	1.85 H	63	6.90	41.80
4	9748.00	55.10 PK	74.00	-18.90	1.59 H	35	10.50	44.60
4	9748.00	41.80 AV	54.00	-12.20	1.59 H	35	-2.80	44.60

ANTENNA POLARITY & TEST DISTANCE: VERTICAL AT 3 M

No.	Freq. (MHz)	Emission Level (dBuV/m)	Limit (dBuV/m)	Margin (dB)	Antenna Height (m)	Table Angle (Degree)	Raw Value (dBuV)	Correction Factor (dB/m)
1	*2437.00	106.20 PK			1.52 V	41	76.20	30.00
1	*2437.00	98.00 AV			1.52 V	41	68.00	30.00
2	4874.00	64.70 PK	74.00	-9.30	1.54 V	89	28.20	36.50
2	4874.00	51.40 AV	54.00	-2.60	1.54 V	89	14.90	36.50
3	7311.00	65.40 PK	74.00	-8.60	1.20 V	55	23.60	41.80
3	7311.00	51.70 AV	54.00	-2.30	1.20 V	55	9.90	41.80
4	9748.00	56.80 PK	74.00	-17.20	1.01 V	47	12.10	44.60
4	9748.00	42.80 AV	54.00	-11.20	1.01 V	47	-1.80	44.60

- REMARKS:**
1. Emission level(dBuV/m)=Raw Value(dBuV) + Correction Factor(dB)
 2. Correction Factor(dB/m) = Antenna Factor (dB/m) + Cable Factor (dB)
 3. The other emission levels were very low against the limit.
 4. Margin value = Emission level – Limit value.
 5. The limit value is defined as per 15.247
 6. “ * “ : Fundamental frequency



EUT	802.11b/g MiniPCI module	MODEL	T60H786
MODE	Channel 11	FREQUENCY RANGE	1000 ~ 25000 MHz
INPUT POWER (SYSTEM)	120Vac, 60 Hz	DETECTOR FUNCTION	Peak(PK) Average (AV)
ENVIRONMENTAL CONDITIONS	20 deg. C, 60 % RH, 974 hPa	TESTED BY	Eric Lee

ANTENNA POLARITY & TEST DISTANCE: HORIZONTAL AT 3 M

No.	Freq. (MHz)	Emission Level (dBuV/m)	Limit (dBuV/m)	Margin (dB)	Antenna Height (m)	Table Angle (Degree)	Raw Value (dBuV)	Correction Factor (dB/m)
1	*2462.00	101.30 PK			1.40 H	262	71.20	30.10
1	*2462.00	93.10 AV			1.40 H	262	63.00	30.10
2	2483.50	58.50 PK	74.00	-15.50	1.52 H	52	28.40	30.10
2	2483.50	48.10 AV	54.00	-5.90	1.52 H	52	18.00	30.10
3	4924.00	57.90 PK	74.00	-16.10	1.11 H	85	21.20	36.70
3	4924.00	46.20 AV	54.00	-7.80	1.11 H	85	9.50	36.70
4	7386.00	53.50 PK	74.00	-20.50	1.08 H	352	11.70	41.80
4	7386.00	39.50 AV	54.00	-14.50	1.08 H	352	-2.40	41.80
5	9848.00	53.90 PK	74.00	-20.10	1.12 H	57	9.50	44.40
5	9848.00	41.20 AV	54.00	-12.80	1.12 H	57	-3.10	44.40

ANTENNA POLARITY & TEST DISTANCE: VERTICAL AT 3 M

No.	Freq. (MHz)	Emission Level (dBuV/m)	Limit (dBuV/m)	Margin (dB)	Antenna Height (m)	Table Angle (Degree)	Raw Value (dBuV)	Correction Factor (dB/m)
1	*2462.00	104.10 PK			1.38 V	250	74.00	30.10
1	*2462.00	95.10 AV			1.38 V	250	65.00	30.10
2	2483.50	60.00 PK	74.00	-14.00	1.52 V	36	29.90	30.10
2	2483.50	51.30 AV	54.00	-2.70	1.52 V	36	21.10	30.10
3	4924.00	61.20 PK	74.00	-12.80	1.11 V	129	24.50	36.70
3	4924.00	49.00 AV	54.00	-5.00	1.11 V	129	12.30	36.70
4	7386.00	56.80 PK	74.00	-17.20	1.01 V	196	15.00	41.80
4	7386.00	43.50 AV	54.00	-10.50	1.01 V	196	1.70	41.80
5	9848.00	54.60 PK	74.00	-19.40	1.29 V	157	10.20	44.40
5	9848.00	41.20 AV	54.00	-12.80	1.29 V	157	-3.10	44.40

- REMARKS:**
1. Emission level(dBuV/m)=Raw Value(dBuV) + Correction Factor(dB)
 2. Correction Factor(dB/m) = Antenna Factor (dB/m) + Cable Factor (dB)
 3. The other emission levels were very low against the limit.
 4. Margin value = Emission level – Limit value.
 5. The limit value is defined as per 15.247
 6. “ * ” : Fundamental frequency



4.2.9 TEST RESULTS (II)- ANTENNA 3

EUT	802.11b/g MiniPCI module	MODEL	T60H786
MODE	Channel 11	FREQUENCY RANGE	30-1000 MHz
INPUT POWER (SYSTEM)	120Vac, 60 Hz	DETECTOR FUNCTION	Quasi-Peak
ENVIRONMENTAL CONDITIONS	20 deg. C, 60 % RH, 974 hPa	TESTED BY	Eric Lee

ANTENNA POLARITY & TEST DISTANCE: HORIZONTAL AT 3 M

No.	Freq. (MHz)	Emission Level (dBuV/m)	Limit (dBuV/m)	Margin (dB)	Antenna Height (m)	Table Angle (Degree)	Raw Value (dBuV)	Correction Factor (dB/m)
1	65.24	24.20 QP	40.00	-15.80	1.35 H	2	16.80	7.40
2	199.98	28.00 QP	43.50	-15.50	1.00 H	98	16.80	11.10
3	234.06	34.30 QP	46.00	-11.70	1.53 H	62	21.80	12.50
4	266.87	38.20 QP	46.00	-7.80	1.80 H	52	23.20	15.00
5	299.96	43.60 QP	46.00	-2.40	1.08 H	359	28.00	15.60
6	400.00	33.10 QP	46.00	-12.90	1.53 H	69	14.30	18.80
7	499.37	34.50 QP	46.00	-11.50	1.10 H	9	13.20	21.30
8	666.23	40.30 QP	46.00	-5.70	1.27 H	96	17.40	22.90
9	770.16	40.90 QP	46.00	-5.10	1.75 H	224	16.80	24.10
10	799.83	42.70 QP	46.00	-3.30	1.54 H	44	18.50	24.20

ANTENNA POLARITY & TEST DISTANCE: VERTICAL AT 3 M

No.	Freq. (MHz)	Emission Level (dBuV/m)	Limit (dBuV/m)	Margin (dB)	Antenna Height (m)	Table Angle (Degree)	Raw Value (dBuV)	Correction Factor (dB/m)
1	66.64	27.90 QP	40.00	-12.10	1.74 V	235	20.80	7.10
2	200.03	26.30 QP	43.50	-17.20	1.14 V	32	15.20	11.10
3	233.45	35.60 QP	46.00	-10.40	1.59 V	319	23.20	12.40
4	266.81	37.60 QP	46.00	-8.40	1.37 V	200	22.60	15.00
5	299.92	41.70 QP	46.00	-4.30	1.29 V	325	26.10	15.60
6	399.92	35.60 QP	46.00	-10.40	1.50 V	189	16.80	18.80
7	500.48	35.10 QP	46.00	-10.90	1.07 V	149	13.80	21.30
8	664.92	43.00 QP	46.00	-3.00	1.39 V	224	20.10	22.90
9	770.47	36.10 QP	46.00	-9.90	1.37 V	65	12.10	24.10
10	799.75	41.00 QP	46.00	-5.00	1.33 V	270	16.80	24.20

- REMARKS:**
1. Emission level(dBuV/m)=Raw Value(dBuV) + Correction Factor(dB)
 2. Correction Factor(dB/m) = Antenna Factor (dB/m) + Cable Factor (dB)
 3. The other emission levels were very low against the limit.
 4. Margin value = Emission level – Limit value.



4.2.10 TEST RESULTS (II)- Antenna 3, DSSS

EUT	802.11b/g MiniPCI module	MODEL	T60H786
MODE	Channel 1	FREQUENCY RANGE	1000 ~ 25000 MHz
INPUT POWER (SYSTEM)	120Vac, 60 Hz	DETECTOR FUNCTION	Peak(PK) Average(AV)
ENVIRONMENTAL CONDITIONS	19 deg. C, 69 % RH, 974 hPa	TESTED BY	Eric Lee

ANTENNA POLARITY & TEST DISTANCE: HORIZONTAL AT 3 M

No.	Freq. (MHz)	Emission Level (dBuV/m)	Limit (dBuV/m)	Margin (dB)	Antenna Height (m)	Table Angle (Degree)	Raw Value (dBuV)	Correction Factor (dB/m)
1	2360.00	49.70 PK	74.00	-24.30	1.01 H	356	20.00	29.70
2	2390.00	51.10 PK	74.00	-22.90	1.53 H	263	21.30	29.80
2	2390.00	43.80 AV	54.00	-10.20	1.53 H	263	14.00	29.80
3	*2412.00	103.40 PK			1.25 H	47	73.50	29.90
3	*2412.00	96.60 AV			1.25 H	47	66.80	29.90
4	4824.00	48.20 PK	74.00	-25.80	1.69 H	65	11.90	36.20
5	7236.00	49.00 PK	74.00	-25.00	1.25 H	89	7.30	41.70
6	9648.00	51.90 PK	74.00	-22.10	1.21 H	60	7.00	44.90
6	9648.00	41.10 AV	54.00	-12.90	1.21 H	60	-3.80	44.90

ANTENNA POLARITY & TEST DISTANCE: VERTICAL AT 3 M

No.	Freq. (MHz)	Emission Level (dBuV/m)	Limit (dBuV/m)	Margin (dB)	Antenna Height (m)	Table Angle (Degree)	Raw Value (dBuV)	Correction Factor (dB/m)
1	2360.00	46.00 PK	74.00	-28.00	1.69 V	99	16.30	29.70
2	2390.00	49.40 PK	74.00	-24.60	1.47 V	87	19.60	29.80
3	*2412.00	100.10 PK			1.12 V	124	70.20	29.90
3	*2412.00	93.00 AV			1.12 V	124	63.10	29.90
4	4824.00	54.70 PK	74.00	-19.30	1.54 V	74	18.50	36.20
4	4824.00	43.80 AV	54.00	-10.20	1.54 V	74	7.60	36.20
5	7236.00	51.90 PK	74.00	-22.10	1.53 V	62	10.20	41.70
5	7236.00	42.50 AV	54.00	-11.50	1.53 V	62	0.90	41.70
6	9648.00	51.10 PK	74.00	-22.90	1.40 V	253	6.20	44.90
6	9648.00	42.50 AV	54.00	-11.50	1.40 V	253	-2.40	44.90

- REMARKS:**
1. Emission level(dBuV/m)=Raw Value(dBuV) + Correction Factor(dB)
 2. Correction Factor(dB/m) = Antenna Factor (dB/m) + Cable Factor (dB)
 3. The other emission levels were very low against the limit.
 4. Margin value = Emission level – Limit value.
 5. The limit value is defined as per 15.247
 6. “ * “ : Fundamental frequency



EUT	802.11b/g MiniPCI module	MODEL	T60H786
MODE	Channel 6	FREQUENCY RANGE	1000 ~ 25000 MHz
INPUT POWER (SYSTEM)	120Vac, 60 Hz	DETECTOR FUNCTION	Peak(PK) Average (AV)
ENVIRONMENTAL CONDITIONS	19 deg. C, 69 % RH, 974 hPa	TESTED BY	Eric Lee

ANTENNA POLARITY & TEST DISTANCE: HORIZONTAL AT 3 M

No.	Freq. (MHz)	Emission Level (dBuV/m)	Limit (dBuV/m)	Margin (dB)	Antenna Height (m)	Table Angle (Degree)	Raw Value (dBuV)	Correction Factor (dB/m)
1	*2437.00	104.00 PK			1.54 H	78	74.00	30.00
1	*2437.00	97.30 AV			1.54 H	78	67.30	30.00
2	4874.00	48.00 PK	74.00	-26.00	1.16 H	97	11.50	36.50
3	7311.00	49.40 PK	74.00	-24.60	1.71 H	105	7.70	41.80
4	9748.00	51.60 PK	74.00	-22.40	1.15 H	300	6.90	44.60
4	9748.00	40.80 AV	54.00	-13.20	1.15 H	300	-3.80	44.60

ANTENNA POLARITY & TEST DISTANCE: VERTICAL AT 3 M

No.	Freq. (MHz)	Emission Level (dBuV/m)	Limit (dBuV/m)	Margin (dB)	Antenna Height (m)	Table Angle (Degree)	Raw Value (dBuV)	Correction Factor (dB/m)
1	*2437.00	101.30 PK			1.00 V	333	71.30	30.00
1	*2437.00	94.30 AV			1.00 V	333	64.30	30.00
2	4874.00	55.60 PK	74.00	-18.40	1.59 V	63	19.20	36.50
2	4874.00	45.30 AV	54.00	-8.70	1.59 V	63	8.90	36.50
3	7311.00	52.40 PK	74.00	-21.60	1.53 V	3	10.60	41.80
3	7311.00	44.20 AV	54.00	-9.80	1.53 V	3	2.40	41.80
4	9748.00	50.60 PK	74.00	-23.40	1.11 V	8	5.90	44.60

- REMARKS:**
1. Emission level(dBuV/m)=Raw Value(dBuV) + Correction Factor(dB)
 2. Correction Factor(dB/m) = Antenna Factor (dB/m) + Cable Factor (dB)
 3. The other emission levels were very low against the limit.
 4. Margin value = Emission level – Limit value.
 5. The limit value is defined as per 15.247
 6. “ * “ : Fundamental frequency



EUT	802.11b/g MiniPCI module	MODEL	T60H786
MODE	Channel 11	FREQUENCY RANGE	1000 ~ 25000 MHz
INPUT POWER (SYSTEM)	120Vac, 60 Hz	DETECTOR FUNCTION	Peak(PK) Average (AV)
ENVIRONMENTAL CONDITIONS	19 deg. C, 69 % RH, 974 hPa	TESTED BY	Eric Lee

ANTENNA POLARITY & TEST DISTANCE: HORIZONTAL AT 3 M

No.	Freq. (MHz)	Emission Level (dBuV/m)	Limit (dBuV/m)	Margin (dB)	Antenna Height (m)	Table Angle (Degree)	Raw Value (dBuV)	Correction Factor (dB/m)
1	*2462.00	104.10 PK			1.11 H	47	74.00	30.10
1	*2462.00	97.40 AV			1.11 H	47	67.30	30.10
2	2483.50	51.10 PK	74.00	-22.90	1.08 H	337	21.00	30.10
2	2483.50	43.40 AV	54.00	-10.60	1.08 H	337	13.20	30.10
3	4924.00	43.50 PK	74.00	-30.50	1.40 H	25	6.80	36.70
4	7386.00	50.00 PK	74.00	-24.00	1.45 H	99	8.10	41.80
5	9848.00	52.30 PK	74.00	-21.70	1.25 H	87	8.00	44.40
5	9848.00	40.20 AV	54.00	-13.80	1.25 H	87	-4.10	44.40

ANTENNA POLARITY & TEST DISTANCE: VERTICAL AT 3 M

No.	Freq. (MHz)	Emission Level (dBuV/m)	Limit (dBuV/m)	Margin (dB)	Antenna Height (m)	Table Angle (Degree)	Raw Value (dBuV)	Correction Factor (dB/m)
1	*2462.00	101.10 PK			1.18 V	93	71.00	30.10
1	*2462.00	94.40 AV			1.18 V	93	64.30	30.10
2	2483.50	50.10 PK	74.00	-23.90	1.25 V	57	20.00	30.10
3	4924.00	56.20 PK	74.00	-17.80	1.26 V	36	19.50	36.70
3	4924.00	45.50 AV	54.00	-8.50	1.26 V	36	8.80	36.70
4	7386.00	52.60 PK	74.00	-21.40	1.63 V	333	10.70	41.80
4	7386.00	43.50 AV	54.00	-10.50	1.63 V	333	1.60	41.80
5	9848.00	51.70 PK	74.00	-22.30	1.11 V	58	7.30	44.40
5	9848.00	42.60 AV	54.00	-11.40	1.11 V	58	-1.80	44.40

- REMARKS:**
1. Emission level(dBuV/m)= Raw Value(dBuV) + Correction Factor(dB)
 2. Correction Factor(dB/m) = Antenna Factor (dB/m) + Cable Factor (dB)
 3. The other emission levels were very low against the limit.
 4. Margin value = Emission level – Limit value.
 5. The limit value is defined as per 15.247
 6. “ * “ : Fundamental frequency



4.2.11 TEST RESULTS (II)- Antenna 3, OFDM

EUT	802.11b/g MiniPCI module	MODEL	T60H786
MODE	Channel 1	FREQUENCY RANGE	1000 ~ 25000 MHz
INPUT POWER (SYSTEM)	120Vac, 60 Hz	DETECTOR FUNCTION	Peak(PK) Average(AV)
ENVIRONMENTAL CONDITIONS	19 deg. C, 69 % RH, 974 hPa	TESTED BY	Eric Lee

ANTENNA POLARITY & TEST DISTANCE: HORIZONTAL AT 3 M

No.	Freq. (MHz)	Emission Level (dBuV/m)	Limit (dBuV/m)	Margin (dB)	Antenna Height (m)	Table Angle (Degree)	Raw Value (dBuV)	Correction Factor (dB/m)
1	2360.00	56.00 PK	74.00	-18.00	1.41 H	202	26.40	29.70
1	2360.00	47.00 AV	54.00	-7.00	1.41 H	202	17.30	29.70
2	2390.00	59.20 PK	74.00	-14.80	1.53 H	62	29.30	29.80
2	2390.00	51.00 AV	54.00	-3.00	1.53 H	62	21.20	29.80
3	*2412.00	101.30 PK			1.01 H	30	71.40	29.90
3	*2412.00	93.60 AV			1.01 H	30	63.70	29.90
4	4824.00	45.10 PK	74.00	-28.90	1.54 H	26	8.90	36.20
5	7236.00	50.60 PK	74.00	-23.40	1.52 H	8	8.90	41.70
6	9648.00	52.20 PK	74.00	-21.80	1.26 H	96	7.30	44.90
6	9648.00	40.20 AV	54.00	-13.80	1.26 H	96	-4.70	44.90

ANTENNA POLARITY & TEST DISTANCE: VERTICAL AT 3 M

No.	Freq. (MHz)	Emission Level (dBuV/m)	Limit (dBuV/m)	Margin (dB)	Antenna Height (m)	Table Angle (Degree)	Raw Value (dBuV)	Correction Factor (dB/m)
1	2360.00	49.70 PK	74.00	-24.30	1.14 V	78	20.00	29.70
2	2390.00	55.20 PK	74.00	-18.80	1.25 V	35	25.30	29.80
2	2390.00	47.10 AV	54.00	-6.90	1.25 V	35	17.30	29.80
3	*2412.00	98.90 PK			1.01 V	251	69.00	29.90
3	*2412.00	91.10 AV			1.01 V	251	61.20	29.90
4	4824.00	47.10 PK	74.00	-26.90	1.01 V	92	10.90	36.20
5	7236.00	51.90 PK	74.00	-22.10	1.43 V	62	10.20	41.70
5	7236.00	41.60 AV	54.00	-12.40	1.43 V	62	-0.10	41.70
6	9648.00	52.50 PK	74.00	-21.50	1.53 V	6	7.60	44.90
6	9648.00	41.50 AV	54.00	-12.50	1.53 V	6	-3.40	44.90

- REMARKS:**
1. Emission level(dBuV/m)=Raw Value(dBuV) + Correction Factor(dB)
 2. Correction Factor(dB/m) = Antenna Factor (dB/m) + Cable Factor (dB)
 3. The other emission levels were very low against the limit.
 4. Margin value = Emission level – Limit value.
 5. The limit value is defined as per 15.247
 6. " * " : Fundamental frequency



EUT	802.11b/g MiniPCI module	MODEL	T60H786
MODE	Channel 6	FREQUENCY RANGE	1000 ~ 25000 MHz
INPUT POWER (SYSTEM)	120Vac, 60 Hz	DETECTOR FUNCTION	Peak(PK) Average (AV)
ENVIRONMENTAL CONDITIONS	19 deg. C, 69 % RH, 974 hPa	TESTED BY	Eric Lee

ANTENNA POLARITY & TEST DISTANCE: HORIZONTAL AT 3 M

No.	Freq. (MHz)	Emission Level (dBuV/m)	Limit (dBuV/m)	Margin (dB)	Antenna Height (m)	Table Angle (Degree)	Raw Value (dBuV)	Correction Factor (dB/m)
1	*2437.00	103.20 PK			1.51 H	42	73.20	30.00
1	*2437.00	95.30 AV			1.51 H	42	65.30	30.00
2	4874.00	45.70 PK	74.00	-28.30	1.02 H	89	9.20	36.50
3	7311.00	52.30 PK	74.00	-21.70	1.82 H	63	10.60	41.80
3	7311.00	41.90 AV	54.00	-12.10	1.82 H	63	0.10	41.80
4	9748.00	53.20 PK	74.00	-20.80	1.68 H	95	8.60	44.60
4	9748.00	41.20 AV	54.00	-12.80	1.68 H	95	-3.40	44.60

ANTENNA POLARITY & TEST DISTANCE: VERTICAL AT 3 M

No.	Freq. (MHz)	Emission Level (dBuV/m)	Limit (dBuV/m)	Margin (dB)	Antenna Height (m)	Table Angle (Degree)	Raw Value (dBuV)	Correction Factor (dB/m)
1	*2437.00	100.00 PK			1.02 V	356	70.00	30.00
1	*2437.00	93.20 AV			1.02 V	356	63.20	30.00
2	4874.00	48.90 PK	74.00	-25.10	1.55 V	245	12.50	36.50
3	7311.00	53.70 PK	74.00	-20.30	1.23 V	65	11.90	41.80
3	7311.00	43.70 AV	54.00	-10.30	1.23 V	65	1.90	41.80
4	9748.00	52.80 PK	74.00	-21.20	1.54 V	218	8.10	44.60
4	9748.00	42.10 AV	54.00	-11.90	1.54 V	218	-2.60	44.60

- REMARKS:**
1. Emission level(dBuV/m)=Raw Value(dBuV) + Correction Factor(dB)
 2. Correction Factor(dB/m) = Antenna Factor (dB/m) + Cable Factor (dB)
 3. The other emission levels were very low against the limit.
 4. Margin value = Emission level – Limit value.
 5. The limit value is defined as per 15.247
 6. “ * “ : Fundamental frequency



EUT	802.11b/g MiniPCI module	MODEL	T60H786
MODE	Channel 11	FREQUENCY RANGE	1000 ~ 25000 MHz
INPUT POWER (SYSTEM)	120Vac, 60 Hz	DETECTOR FUNCTION	Peak(PK) Average (AV)
ENVIRONMENTAL CONDITIONS	19 deg. C, 69 % RH, 974 hPa	TESTED BY	Eric Lee

ANTENNA POLARITY & TEST DISTANCE: HORIZONTAL AT 3 M

No.	Freq. (MHz)	Emission Level (dBuV/m)	Limit (dBuV/m)	Margin (dB)	Antenna Height (m)	Table Angle (Degree)	Raw Value (dBuV)	Correction Factor (dB/m)
1	*2462.00	101.10 PK			1.05 H	96	71.00	30.10
1	*2462.00	93.10 AV			1.05 H	96	63.00	30.10
2	2483.50	59.10 PK	74.00	-14.90	1.14 H	75	29.00	30.10
2	2483.50	50.50 AV	54.00	-3.50	1.14 H	75	20.40	30.10
3	4924.00	45.90 PK	74.00	-28.10	1.56 H	98	9.20	36.70
4	7386.00	51.50 PK	74.00	-22.50	1.43 H	62	9.70	41.80
4	7386.00	40.30 AV	54.00	-13.70	1.43 H	62	-1.60	41.80
5	9848.00	51.00 PK	74.00	-23.00	1.11 H	96	6.70	44.40
5	9848.00	40.30 AV	54.00	-13.70	1.11 H	96	-4.10	44.40

ANTENNA POLARITY & TEST DISTANCE: VERTICAL AT 3 M

No.	Freq. (MHz)	Emission Level (dBuV/m)	Limit (dBuV/m)	Margin (dB)	Antenna Height (m)	Table Angle (Degree)	Raw Value (dBuV)	Correction Factor (dB/m)
1	*2462.00	97.40 PK			1.55 V	69	67.40	30.10
1	*2462.00	90.30 AV			1.55 V	69	60.20	30.10
2	2483.50	57.00 PK	74.00	-17.00	1.11 V	239	26.80	30.10
2	2483.50	48.50 AV	54.00	-5.50	1.11 V	239	18.40	30.10
3	4924.00	46.10 PK	74.00	-27.90	1.23 V	69	9.40	36.70
4	7386.00	50.60 PK	74.00	-23.40	1.52 V	258	8.70	41.80
5	9848.00	52.00 PK	74.00	-22.00	1.40 V	69	7.70	44.40
5	9848.00	40.60 AV	54.00	-13.40	1.40 V	69	-3.80	44.40

- REMARKS:**
1. Emission level(dBuV/m)=Raw Value(dBuV) + Correction Factor(dB)
 2. Correction Factor(dB/m) = Antenna Factor (dB/m) + Cable Factor (dB)
 3. The other emission levels were very low against the limit.
 4. Margin value = Emission level – Limit value.
 5. The limit value is defined as per 15.247
 6. “ * “ : Fundamental frequency



4.2.12 TEST RESULTS (III)- ANTENNA 4

EUT	802.11b/g MiniPCI module	MODEL	T60H786
MODE	Channel 11	FREQUENCY RANGE	30-1000 MHz
INPUT POWER (SYSTEM)	120Vac, 60 Hz	DETECTOR FUNCTION	Quasi-Peak
ENVIRONMENTAL CONDITIONS	19 deg. C, 69 % RH, 974 hPa	TESTED BY	Eric Lee

ANTENNA POLARITY & TEST DISTANCE: HORIZONTAL AT 3 M

No.	Freq. (MHz)	Emission Level (dBuV/m)	Limit (dBuV/m)	Margin (dB)	Antenna Height (m)	Table Angle (Degree)	Raw Value (dBuV)	Correction Factor (dB/m)
1	66.24	22.40 QP	40.00	-17.60	1.54 H	74	15.20	7.20
2	199.69	26.40 QP	43.50	-17.10	1.01 H	247	15.20	11.10
3	233.00	34.40 QP	46.00	-11.60	1.46 H	326	22.00	12.40
4	266.35	40.30 QP	46.00	-5.70	1.46 H	95	25.20	15.00
5	299.63	42.80 QP	46.00	-3.20	1.52 H	326	27.20	15.60
6	399.84	34.00 QP	46.00	-12.00	1.07 H	55	15.20	18.80
7	500.23	37.50 QP	46.00	-8.50	1.59 H	357	16.20	21.30
8	666.32	39.10 QP	46.00	-6.90	1.33 H	69	16.20	22.90
9	770.31	40.80 QP	46.00	-5.20	1.07 H	184	16.70	24.10
10	799.63	41.40 QP	46.00	-4.60	1.02 H	289	17.20	24.20

ANTENNA POLARITY & TEST DISTANCE: VERTICAL AT 3 M

No.	Freq. (MHz)	Emission Level (dBuV/m)	Limit (dBuV/m)	Margin (dB)	Antenna Height (m)	Table Angle (Degree)	Raw Value (dBuV)	Correction Factor (dB/m)
1	66.34	27.10 QP	40.00	-12.90	1.09 V	73	20.00	7.10
2	199.86	27.40 QP	43.50	-16.10	1.70 V	209	16.30	11.10
3	240.26	31.80 QP	46.00	-14.20	1.54 V	54	18.50	13.30
4	299.67	43.20 QP	46.00	-2.80	1.28 V	96	27.60	15.60
5	400.25	35.80 QP	46.00	-10.20	1.11 V	9	17.00	18.80
6	499.91	35.60 QP	46.00	-10.40	1.58 V	178	14.30	21.30
7	536.00	40.70 QP	46.00	-5.30	1.00 V	30	18.60	22.10
8	599.98	32.20 QP	46.00	-13.80	1.57 V	84	10.00	22.20
9	666.03	41.40 QP	46.00	-4.60	1.13 V	308	18.40	22.90
10	799.68	39.40 QP	46.00	-6.60	1.02 V	87	15.20	24.20

- REMARKS:**
1. Emission level(dBuV/m)=Raw Value(dBuV) + Correction Factor(dB)
 2. Correction Factor(dB/m) = Antenna Factor (dB/m) + Cable Factor (dB)
 3. The other emission levels were very low against the limit.
 4. Margin value = Emission level – Limit value.



4.2.13 TEST RESULTS (III)- Antenna 4, DSSS

EUT	802.11b/g MiniPCI module	MODEL	T60H786
MODE	Channel 1	FREQUENCY RANGE	1000 ~ 25000 MHz
INPUT POWER (SYSTEM)	120Vac, 60 Hz	DETECTOR FUNCTION	Peak(PK) Average(AV)
ENVIRONMENTAL CONDITIONS	19 deg. C, 69 % RH, 974 hPa	TESTED BY	Eric Lee

ANTENNA POLARITY & TEST DISTANCE: HORIZONTAL AT 3 M

No.	Freq. (MHz)	Emission Level (dBuV/m)	Limit (dBuV/m)	Margin (dB)	Antenna Height (m)	Table Angle (Degree)	Raw Value (dBuV)	Correction Factor (dB/m)
1	2360.00	49.00 PK	74.00	-25.00	1.06 H	96	19.40	29.70
2	2390.00	50.50 PK	74.00	-23.50	1.11 H	78	20.70	29.80
3	*2412.00	105.10 PK			1.30 H	90	75.20	29.90
3	*2412.00	99.50 AV			1.30 H	90	69.70	29.90
4	4824.00	49.80 PK	74.00	-24.20	1.69 H	96	13.50	36.20
5	7236.00	50.50 PK	74.00	-23.50	1.11 H	57	8.90	41.70
6	9648.00	50.70 PK	74.00	-23.30	1.77 H	47	5.80	44.90

ANTENNA POLARITY & TEST DISTANCE: VERTICAL AT 3 M

No.	Freq. (MHz)	Emission Level (dBuV/m)	Limit (dBuV/m)	Margin (dB)	Antenna Height (m)	Table Angle (Degree)	Raw Value (dBuV)	Correction Factor (dB/m)
1	2360.00	47.90 PK	74.00	-26.10	1.02 V	42	18.20	29.70
2	2390.00	49.10 PK	74.00	-24.90	1.63 V	356	19.30	29.80
3	*2412.00	101.10 PK			1.53 V	69	71.20	29.90
3	*2412.00	95.10 AV			1.53 V	69	65.20	29.90
4	4824.00	58.80 PK	74.00	-15.20	1.30 V	257	22.50	36.20
4	4824.00	47.50 AV	54.00	-6.50	1.30 V	257	11.30	36.20
5	7236.00	57.50 PK	74.00	-16.50	1.43 V	62	15.80	41.70
5	7236.00	49.60 AV	54.00	-4.40	1.43 V	62	7.90	41.70
6	9648.00	54.10 PK	74.00	-19.90	1.31 V	25	9.20	44.90
6	9648.00	45.50 AV	54.00	-8.50	1.31 V	25	0.60	44.90

- REMARKS:**
1. Emission level(dBuV/m)=Raw Value(dBuV) + Correction Factor(dB)
 2. Correction Factor(dB/m) = Antenna Factor (dB/m) + Cable Factor (dB)
 3. The other emission levels were very low against the limit.
 4. Margin value = Emission level – Limit value.
 5. The limit value is defined as per 15.247
 6. “ * “ : Fundamental frequency



EUT	802.11b/g MiniPCI module	MODEL	T60H786
MODE	Channel 6	FREQUENCY RANGE	1000 ~ 25000 MHz
INPUT POWER (SYSTEM)	120Vac, 60 Hz	DETECTOR FUNCTION	Peak(PK) Average (AV)
ENVIRONMENTAL CONDITIONS	19 deg. C, 69 % RH, 974 hPa	TESTED BY	Eric Lee

ANTENNA POLARITY & TEST DISTANCE: HORIZONTAL AT 3 M

No.	Freq. (MHz)	Emission Level (dBuV/m)	Limit (dBuV/m)	Margin (dB)	Antenna Height (m)	Table Angle (Degree)	Raw Value (dBuV)	Correction Factor (dB/m)
1	*2437.00	106.20 PK			1.11 H	326	76.20	30.00
1	*2437.00	99.30 AV			1.11 H	326	69.30	30.00
2	4874.00	48.90 PK	74.00	-25.10	1.12 H	57	12.50	36.50
3	7311.00	50.40 PK	74.00	-23.60	1.04 H	346	8.70	41.80
4	9748.00	49.60 PK	74.00	-24.40	1.31 H	36	4.90	44.60

ANTENNA POLARITY & TEST DISTANCE: VERTICAL AT 3 M

No.	Freq. (MHz)	Emission Level (dBuV/m)	Limit (dBuV/m)	Margin (dB)	Antenna Height (m)	Table Angle (Degree)	Raw Value (dBuV)	Correction Factor (dB/m)
1	*2437.00	102.00 PK			1.08 V	32	72.00	30.00
1	*2437.00	95.70 AV			1.08 V	32	65.70	30.00
2	4874.00	59.00 PK	74.00	-15.00	1.11 V	52	22.60	36.50
2	4874.00	47.90 AV	54.00	-6.10	1.11 V	52	11.50	36.50
3	7311.00	57.50 PK	74.00	-16.50	1.02 V	88	15.80	41.80
3	7311.00	51.10 AV	54.00	-2.90	1.02 V	88	9.30	41.80
4	9748.00	53.80 PK	74.00	-20.20	1.33 V	69	9.20	44.60
4	9748.00	44.80 AV	54.00	-9.20	1.33 V	69	0.20	44.60

- REMARKS:**
1. Emission level(dBuV/m)=Raw Value(dBuV) + Correction Factor(dB)
 2. Correction Factor(dB/m) = Antenna Factor (dB/m) + Cable Factor (dB)
 3. The other emission levels were very low against the limit.
 4. Margin value = Emission level – Limit value.
 5. The limit value is defined as per 15.247
 6. “ * “ : Fundamental frequency



EUT	802.11b/g MiniPCI module	MODEL	T60H786
MODE	Channel 11	FREQUENCY RANGE	1000 ~ 25000 MHz
INPUT POWER (SYSTEM)	120Vac, 60 Hz	DETECTOR FUNCTION	Peak(PK) Average (AV)
ENVIRONMENTAL CONDITIONS	19 deg. C, 69 % RH, 974 hPa	TESTED BY	Eric Lee

ANTENNA POLARITY & TEST DISTANCE: HORIZONTAL AT 3 M

No.	Freq. (MHz)	Emission Level (dBuV/m)	Limit (dBuV/m)	Margin (dB)	Antenna Height (m)	Table Angle (Degree)	Raw Value (dBuV)	Correction Factor (dB/m)
1	*2462.00	106.30 PK			1.30 H	222	76.20	30.10
1	*2462.00	98.30 AV			1.30 H	222	68.30	30.10
2	2483.50	51.70 PK	74.00	-22.30	1.43 H	69	21.60	30.10
2	2483.50	43.40 AV	54.00	-10.60	1.43 H	69	13.30	30.10
3	4924.00	50.10 PK	74.00	-23.90	1.40 H	253	13.40	36.70
4	7386.00	52.20 PK	74.00	-21.80	1.64 H	79	10.30	41.80
4	7386.00	44.90 AV	54.00	-9.10	1.64 H	79	3.10	41.80
5	9848.00	49.30 PK	74.00	-24.70	1.58 H	253	4.90	44.40

ANTENNA POLARITY & TEST DISTANCE: VERTICAL AT 3 M

No.	Freq. (MHz)	Emission Level (dBuV/m)	Limit (dBuV/m)	Margin (dB)	Antenna Height (m)	Table Angle (Degree)	Raw Value (dBuV)	Correction Factor (dB/m)
1	*2462.00	102.40 PK			1.11 V	58	72.40	30.10
1	*2462.00	95.30 AV			1.11 V	58	65.20	30.10
2	2483.50	50.10 PK	74.00	-23.90	1.02 V	96	20.00	30.10
3	4924.00	60.50 PK	74.00	-13.50	1.36 V	52	23.80	36.70
3	4924.00	49.10 AV	54.00	-4.90	1.36 V	52	12.50	36.70
4	7386.00	58.90 PK	74.00	-15.10	1.11 V	207	17.10	41.80
4	7386.00	50.70 AV	54.00	-3.30	1.11 V	207	8.80	41.80
5	9848.00	53.20 PK	74.00	-20.80	1.21 V	257	8.90	44.40
5	9848.00	44.30 AV	54.00	-9.70	1.21 V	257	-0.10	44.40

- REMARKS:**
1. Emission level(dBuV/m)=Raw Value(dBuV) + Correction Factor(dB)
 2. Correction Factor(dB/m) = Antenna Factor (dB/m) + Cable Factor (dB)
 3. The other emission levels were very low against the limit.
 4. Margin value = Emission level – Limit value.
 5. The limit value is defined as per 15.247
 6. “ * “ : Fundamental frequency



4.2.14 TEST RESULTS (III)- Antenna 4, OFDM

EUT	802.11b/g MiniPCI module	MODEL	T60H786
MODE	Channel 1	FREQUENCY RANGE	1000 ~ 25000 MHz
INPUT POWER (SYSTEM)	120Vac, 60 Hz	DETECTOR FUNCTION	Peak(PK) Average(AV)
ENVIRONMENTAL CONDITIONS	19 deg. C, 69 % RH, 974 hPa	TESTED BY	Eric Lee

ANTENNA POLARITY & TEST DISTANCE: HORIZONTAL AT 3 M

No.	Freq. (MHz)	Emission Level (dBuV/m)	Limit (dBuV/m)	Margin (dB)	Antenna Height (m)	Table Angle (Degree)	Raw Value (dBuV)	Correction Factor (dB/m)
1	2360.00	57.00 PK	74.00	-17.00	1.69 H	68	27.30	29.70
1	2360.00	47.90 AV	54.00	-6.10	1.69 H	68	18.20	29.70
2	2390.00	59.10 PK	74.00	-14.90	1.20 H	55	29.30	29.80
2	2390.00	50.70 AV	54.00	-3.30	1.20 H	55	20.90	29.80
3	*2412.00	105.10 PK			1.22 H	48	75.20	29.90
3	*2412.00	96.70 AV			1.22 H	48	66.80	29.90
4	4824.00	47.70 PK	74.00	-26.30	1.45 H	24	11.50	36.20
5	7236.00	50.60 PK	74.00	-23.40	1.63 H	69	9.00	41.70
6	9648.00	52.10 PK	74.00	-21.90	1.54 H	78	7.20	44.90
6	9648.00	40.10 AV	54.00	-13.90	1.54 H	78	-4.80	44.90

ANTENNA POLARITY & TEST DISTANCE: VERTICAL AT 3 M

No.	Freq. (MHz)	Emission Level (dBuV/m)	Limit (dBuV/m)	Margin (dB)	Antenna Height (m)	Table Angle (Degree)	Raw Value (dBuV)	Correction Factor (dB/m)
1	2360.00	55.00 PK	74.00	-19.00	1.11 V	69	25.40	29.70
1	2360.00	46.20 AV	54.00	-7.80	1.11 V	69	16.50	29.70
2	2390.00	58.00 PK	74.00	-16.00	1.43 V	89	28.20	29.80
2	2390.00	49.10 AV	54.00	-4.90	1.43 V	89	19.30	29.80
3	*2412.00	100.80 PK			1.25 V	118	70.90	29.90
3	*2412.00	92.40 AV			1.25 V	118	62.50	29.90
4	4824.00	53.70 PK	74.00	-20.30	1.75 V	64	17.50	36.20
4	4824.00	43.30 AV	54.00	-10.70	1.75 V	64	7.10	36.20
5	7236.00	53.60 PK	74.00	-20.40	1.31 V	356	11.90	41.70
5	7236.00	45.60 AV	54.00	-8.40	1.31 V	356	4.00	41.70
6	9648.00	52.90 PK	74.00	-21.10	1.52 V	47	8.00	44.90
6	9648.00	42.20 AV	54.00	-11.80	1.52 V	47	-2.70	44.90

- REMARKS:**
1. Emission level(dBuV/m)=Raw Value(dBuV) + Correction Factor(dB)
 2. Correction Factor(dB/m) = Antenna Factor (dB/m) + Cable Factor (dB)
 3. The other emission levels were very low against the limit.
 4. Margin value = Emission level – Limit value.
 5. The limit value is defined as per 15.247
 6. “ * “ : Fundamental frequency



EUT	802.11b/g MiniPCI module	MODEL	T60H786
MODE	Channel 6	FREQUENCY RANGE	1000 ~ 25000 MHz
INPUT POWER (SYSTEM)	120Vac, 60 Hz	DETECTOR FUNCTION	Peak(PK) Average (AV)
ENVIRONMENTAL CONDITIONS	19 deg. C, 69 % RH, 974 hPa	TESTED BY	Eric Lee

ANTENNA POLARITY & TEST DISTANCE: HORIZONTAL AT 3 M

No.	Freq. (MHz)	Emission Level (dBuV/m)	Limit (dBuV/m)	Margin (dB)	Antenna Height (m)	Table Angle (Degree)	Raw Value (dBuV)	Correction Factor (dB/m)
1	*2437.00	107.10 PK			1.45 H	78	77.10	30.00
1	*2437.00	99.20 AV			1.45 H	78	69.20	30.00
2	4874.00	51.90 PK	74.00	-22.10	1.54 H	83	15.50	36.50
2	4874.00	41.70 AV	54.00	-12.30	1.54 H	83	5.20	36.50
3	7311.00	50.70 PK	74.00	-23.30	1.66 H	358	8.90	41.80
4	9748.00	50.30 PK	74.00	-23.70	1.14 H	96	5.60	44.60

ANTENNA POLARITY & TEST DISTANCE: VERTICAL AT 3 M

No.	Freq. (MHz)	Emission Level (dBuV/m)	Limit (dBuV/m)	Margin (dB)	Antenna Height (m)	Table Angle (Degree)	Raw Value (dBuV)	Correction Factor (dB/m)
1	*2437.00	103.20 PK			1.25 V	120	73.20	30.00
1	*2437.00	95.20 AV			1.25 V	120	65.20	30.00
2	4874.00	54.90 PK	74.00	-19.10	1.54 V	74	18.50	36.50
2	4874.00	45.90 AV	54.00	-8.10	1.54 V	74	9.50	36.50
3	7311.00	55.40 PK	74.00	-18.60	1.11 V	98	13.70	41.80
3	7311.00	47.60 AV	54.00	-6.40	1.11 V	98	5.90	41.80
4	9748.00	53.80 PK	74.00	-20.20	1.36 V	98	9.10	44.60
4	9748.00	43.80 AV	54.00	-10.20	1.36 V	98	-0.90	44.60

- REMARKS:**
1. Emission level(dBuV/m)=Raw Value(dBuV) + Correction Factor(dB)
 2. Correction Factor(dB/m) = Antenna Factor (dB/m) + Cable Factor (dB)
 3. The other emission levels were very low against the limit.
 4. Margin value = Emission level – Limit value.
 5. The limit value is defined as per 15.247
 6. “ * “ : Fundamental frequency



EUT	802.11b/g MiniPCI module	MODEL	T60H786
MODE	Channel 11	FREQUENCY RANGE	1000 ~ 25000 MHz
INPUT POWER (SYSTEM)	120Vac, 60 Hz	DETECTOR FUNCTION	Peak(PK) Average (AV)
ENVIRONMENTAL CONDITIONS	19 deg. C, 69 % RH, 974 hPa	TESTED BY	Eric Lee

ANTENNA POLARITY & TEST DISTANCE: HORIZONTAL AT 3 M

No.	Freq. (MHz)	Emission Level (dBuV/m)	Limit (dBuV/m)	Margin (dB)	Antenna Height (m)	Table Angle (Degree)	Raw Value (dBuV)	Correction Factor (dB/m)
1	*2462.00	104.90 PK			1.02 H	36	74.80	30.10
1	*2462.00	95.80 AV			1.02 H	36	65.70	30.10
2	2483.50	60.10 PK	74.00	-13.90	1.58 H	96	30.00	30.10
2	2483.50	52.90 AV	54.00	-1.10	1.58 H	96	22.80	30.10
3	4924.00	49.10 PK	74.00	-24.90	1.47 H	54	12.50	36.70
4	7386.00	51.50 PK	74.00	-22.50	1.02 H	68	9.60	41.80
4	7386.00	42.30 AV	54.00	-11.70	1.02 H	68	0.50	41.80
5	9848.00	49.30 PK	74.00	-24.70	1.11 H	58	5.00	44.40

ANTENNA POLARITY & TEST DISTANCE: VERTICAL AT 3 M

No.	Freq. (MHz)	Emission Level (dBuV/m)	Limit (dBuV/m)	Margin (dB)	Antenna Height (m)	Table Angle (Degree)	Raw Value (dBuV)	Correction Factor (dB/m)
1	*2462.00	101.10 PK			1.11 V	54	71.00	30.10
1	*2462.00	92.30 AV			1.11 V	54	62.30	30.10
2	2483.50	59.50 PK	74.00	-14.50	1.54 V	74	29.30	30.10
2	2483.50	49.10 AV	54.00	-4.90	1.54 V	74	19.00	30.10
3	4924.00	54.10 PK	74.00	-19.90	1.47 V	54	17.40	36.70
3	4924.00	43.40 AV	54.00	-10.60	1.47 V	54	6.70	36.70
4	7386.00	53.90 PK	74.00	-20.10	1.54 V	78	12.00	41.80
4	7386.00	45.60 AV	54.00	-8.40	1.54 V	78	3.80	41.80
5	9848.00	51.30 PK	74.00	-22.70	1.12 V	69	6.90	44.40
5	9848.00	41.30 AV	54.00	-12.70	1.12 V	69	-3.10	44.40

- REMARKS:**
1. Emission level(dBuV/m)=Raw Value(dBuV) + Correction Factor(dB)
 2. Correction Factor(dB/m) = Antenna Factor (dB/m) + Cable Factor (dB)
 3. The other emission levels were very low against the limit.
 4. Margin value = Emission level – Limit value.
 5. The limit value is defined as per 15.247
 6. “ * “ : Fundamental frequency



4.3 6dB BANDWIDTH MEASUREMENT

4.3.1 LIMITS OF 6dB BANDWIDTH MEASUREMENT

The minimum of 6dB Bandwidth Measurement is 0.5 MHz.

4.3.2 TEST INSTRUMENTS

Description & Manufacturer	Model No.	Serial No.	Calibrated Until
R&S SPECTRUM ANALYZER	FSP	1093.4495.30	Dec. 19, 2003

NOTE:

- 1.The measurement uncertainty is less than +/- 2.6dB, which is calculated as per the NAMAS document NIS81.
- 2.The calibration interval of the above test instruments is 12 months and the calibrations are traceable to NML/ROC and NIST/USA.

4.3.3 TEST PROCEDURE

The transmitter output was connected to the spectrum analyzer through an attenuator. The bandwidth of the fundamental frequency was measured by spectrum analyzer with 100 kHz RBW and 100 kHz VBW. The 6 dB bandwidth is defined as the total spectrum the power of which is higher than peak power minus 6 dB.

4.3.4 TEST SETUP

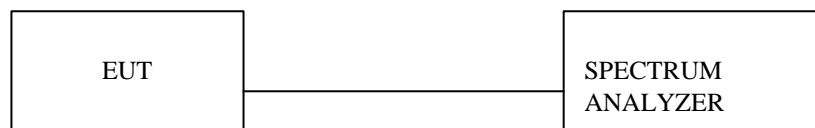

For the actual test configuration, please refer to the related Item – Photographs of the Test Configuration.

4.3.5 EUT OPERATING CONDITIONS

The software provided by client to enable the EUT under transmission condition continuously at lowest, middle and highest channel frequencies individually.