

Measurement Report

Part 15 Subpart B & C (15.247)

Product: ***Wireless PCMCIA Card***
Manufacture: ***AMBIT Microsystems Corporation.***
FCC ID: ***MCLT60H625***
Model: ***T60H625***
Report No.: ***MLT0209P15001***
Test Date: ***September 12.2002***

Test By

Max Light Technology Co.,Ltd.

*Room 5, 8F, No.125, Section 3 Roosevelt Road,
Taipei, Taiwan., R.O.C.*

Tel: 886-2-2363-2447 Fax: 886-2-2363-2597

The test report consists of 70 pages in total. It may be duplicated completely for legal use with the allowance of the applicant. It shall not be reproduced except in full, without the written approval of our laboratory.



Table of Contents :

I. General 4.

II. Conducted Emissions Requirements 11.

III. Radiated Emissions Requirements 19.

IV. Maximum Conducted Output Power Requirements 33.

V. Minimum 6dB RF Bandwidth Requirements 38.

VI. Maximum Power Density Requirements 43.

VII. Out of Band Conducted Emissions Requirements 48.

VIII. Band Edges Requirements 65.

IX. Processing Gain Requirements 67.

X. Antenna Requirements 68.

Appendix I (EUT Test Setup) 69.



CERTIFICATION

We here by verify that :

The test data, data evaluation, test procedures and equipment configurations shown in this report were made in accordance with the procedures given in ANSI C63.4-1992. All test were conducted by *MLT(Max Light Technology Co.,Ltd) Room 5, 8F, No.125, Section 3 Roosevelt Road, Taipei, Taiwan, R.O.C* Also, we attest to the accuracy of each.

We further submit that the energy emitted by the sample EUT tested as described in the report is in compliance with Class B radiated and conducted emission limit of FCC Rules Part 15 Subpart B & C (15.247).

EUT : Wireless PCMCIA Card

Applicant : AMBIT MICROSYSTEMS CORPORATION.
5F-1, 5 Hsin-An Road, Hsinchu
Science-Based Industrial Park, Taiwan

Manufacturer : AMBIT MICROSYSTEMS CORPORATION.
5F-1, 5 Hsin-An Road, Hsinchu
Science-Based Industrial Park, Taiwan

Model No : T60H625

FCC ID : MCLT60H625

Prepared by :  Approved by : 
Country Huang Roger Chen



I. GENERAL

1.1 Introduction

The following measurement report is submitted on behalf of AMBIT Microsystems Corporation. . In support of a Class B Digital Device certification in accordance with Part2 Subpart J and Part 15 Subpart A And B&C of the Commission's and Regulations.

1.2 Description of EUT

EUT : Wireless PCMCIA Card

Applicant : AMBIT MICROSYSTEMS CORPORATION.
5F-1, 5 Hsin-An Road, Hsinchu
Science-Based Industrial Park, Taiwan

Manufacturer : AMBIT MICROSYSTEMS CORPORATION.
5F-1, 5 Hsin-An Road, Hsinchu
Science-Based Industrial Park, Taiwan

Model No : T60H625

FCC ID : MCLT60H625

Power Type : Powered by PC

Frequency of Channel: See Next page

Type of Modulation : Direct Sequence Spread Spectrum

Type of Antenna : Printed Antenna

During testing the EUT was operated at Tx or Rx mode for each emission measured. This was done in order to ensure that maximum emission levels were attained.



MAX LIGHT

MEASUREMENT REPORT

Page: 5/70

Frequency of Each Channel (Working Frequency)

Channel No.	Frequency (MHz)
01	2412
02	2417
03	2422
04	2427
05	2432
06	2437
07	2442
08	2447
09	2452
10	2457
11	2462



1.3 Summary Of Tests

47 CFR Part 15 Subpart C			
Reference	Test	Results	Note
15.107	AC Power Conducted Emission	PASS	
15.247(c)	Transmitter Radiated Emissions	PASS	
15.247(b)	Max. Output Power	PASS	
15.247(a)(2)	6dB RF Bandwidth	PASS	
15.247(d)	Max. Power Density	PASS	
15.247(c)	Out of Band Conducted Spurious Emission	PASS	
15.247(c)	Band Edge Measurement	PASS	
15.247(e)	Processing Gain of Direct Sequence	PASS	Provided by Applicant
15.203	Antenna Requirement	PASS	



1.4 Description of Support Equipment

In order to construct the minimum system which required by the ANSI C63.4-1991, following equipments were used as the support units.

Computer : COMPAQ
Model No. : Prescrio 1700
Serial No. : 54S32009A1
FCC ID : FCC(DOC)

Keyboard(USB) : SOLID YEAR
Model No. : KB-A21S3
Serial No. : DF3DW301
FCC ID : FCC(DOC)

Monitor : IBM
Model No. : 10L6145 030
Serial No. : 23-092079
FCC ID : ARSCM569N

Mouse(USB) : APPLE
Model No. : M4848
Serial No. : AS82201
FCC ID : FCC(DOC)

Printer : PANASONIC
Model No. : KX-P1080I
Serial No. : 7CKAKE98933
FCC ID : ACJ5Z6KX-P10801

Mic : KAKA
Model No. : K186
Serial No. : 7H0101A
FCC ID : N/A



MAX LIGHT
MEASUREMENT REPORT

Page: 8/70

Earphone : KAKA
Model No. : WA67JH
Serial No. : JH87902
FCC ID : N/A

1.4 Configuration of System Under Test

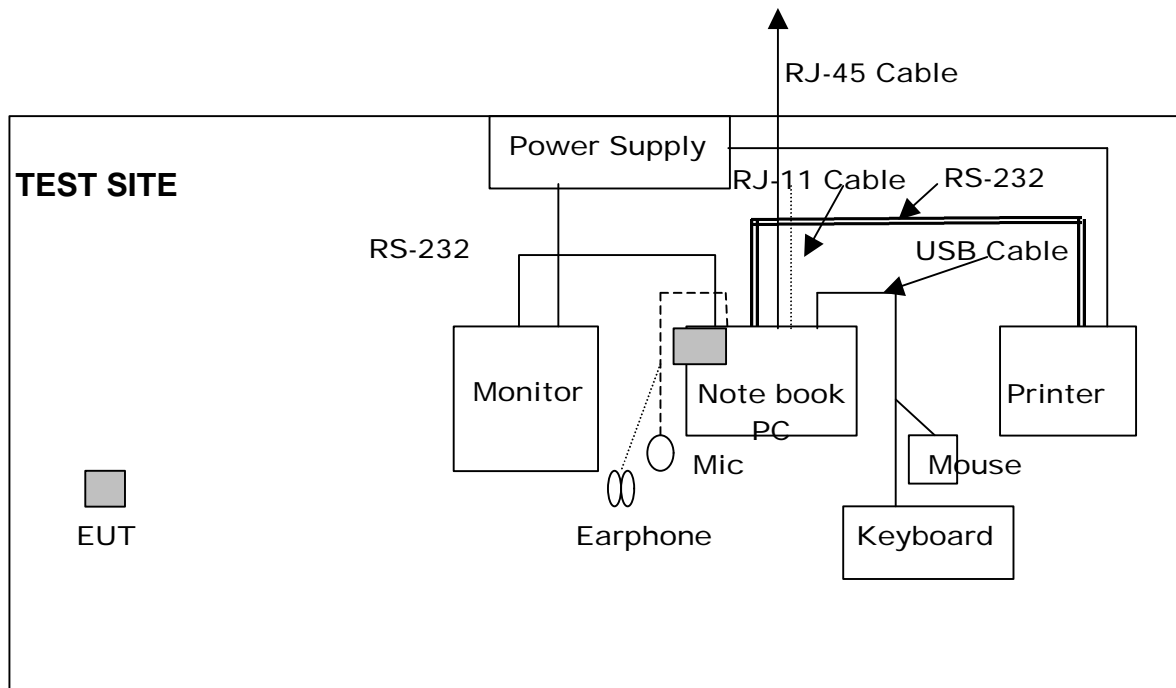

During testing the EUT(Wireless PCMCIA Card) was to plug in PCMCIA port of COMPAQ notebook computer. A mouse(USB) & keyboard (USB) were connected to the USB port of COMPAQ notebook computer. And a printer was connected to the parallel port. A external monitor connected the VGA port and the Mic & Earphone were connected with the audio jack of COMPAQ notebook computer..



1.6 Test Procedure

All measurements contained in this report were performed according to the techniques described in Measurement procedure ANSI C63.4-1992 "Measurement of unIntentional Radiators."

1.7 General Test Condition

The conditions under which the EUT operates were varied to determine their effect on the equipment's emission characteristics. The final configuration of the test system and the mode of operation used during these tests was chosen as that which produced the highest emission levels. However, only those conditions which the EUT was considered likely to encounter in normal use were investigated. The system's radiated and conducted emissions were investigated while the computer alternately transferred data to the EUT as well as to the monitor and printer. Using a test program which sent a continuous data and transferred data to and from the EUT was proven to worst case emissions. The system's physical layout and cabling was randomly arranged to ensure that maximum emission levels were attained.



II. Conducted Emissions Requirements

2.1 General & Setup :

The power line conducted emission measurements were performed in a shielded enclosure. The EUT was assembled on a wooden table which is 80 centimeters high, was placed 40 centimeters from the backwall and at least 1 meter from the sidewall.

Power was fed to the EUT from the public utility power grid through a line filter and EMCO Model 3825/2 Line Impedance Stabilization Networks (LISN). The LISN housing, measuring instrumentation case, ground plane, etc., were electrically bonded together at the same RF potential. The Spectrum analyzer was connected to the AC line through an isolation transformer. The 50-ohm output of the LISN was connected to the spectrum analyzer directly. Conducted emission levels were in the CISPER quasi-peak detection mode. The analyzer's 6 dB bandwidth was set to 9 KHz. No post-detector video filter was used.

The spectrum was scanned from 450 KHz to 30 MHz. The physical arrangement of the test system and associated cabling was varied (within the scope of arrangements likely to be encountered in actual use) to determine the effect on the unit's emanations in amplitude and frequency. All spurious emission frequencies were observed. The highest emission amplitudes relative to the appropriate limit were measured and have been recorded in paragraph 2.6.

2.2 Test Equipment List:

- A. EMCO 3825/2 LISN (S/N:2654)
- B. EMCO 3825/2 LISN (S/N:2658)
- C. HP 8591EM 9KHZ-1.8GHz Spectrum Analyzer (S/N:73412A00110)
- D. Shielded Room (MLT-SR1)

2.3 Test Configuration:



Front View of The Test Configuration



Rear View of The Test Configuration



2.4 Test condition:

EUT tested in accordance with the specifications given by the manufacturer , and exercised in the most unfavorable manner.

2.5 Conducted Emissions Limits:

<i>Frequency range (MHz)</i>	<i>Limits (dBuV)</i>
0.45 to 30	47.9

2.6 Measurement Data Of Conducted Emissions:

2.6.1 Conducted Emissions (Subpart B)

The following table show a summary of the highest emissions of power line conducted emissions to the HOT and NATURAL conductor of the EUT power.

Manufacturer : *AMBIT Microsystems Corporation.*
 Model No : *T60H625*
 EUT : *Wireless PCMCIA Card*
 Test Mode : *Run "Ping" Command*

Power Line Conducted Emissions (Class B)			
Conductor	Frequency (MHz)	Peak Amplitude (dBuV)	Limits (dBuV)
L1	0.48	38.70	47.9
	0.62	35.58	47.9
	0.75	34.10	47.9
	0.83	33.31	47.9
	0.97	33.30	47.9
	3.57	32.02	47.9
	25.59	35.79	47.9
L2	0.48	37.76	47.9
	0.55	36.52	47.9
	0.64	37.09	47.9
	0.75	33.93	47.9
	0.83	34.76	47.9
	0.97	34.76	47.9
	15.07	34.16	47.9

Notes :
 1.L1: One end & Ground L2: The other end & Ground
 2.Height of table on which the EUT was placed : 0.8 m.
 3.The above test results are obtained under the normal condition.



2.6.2 Conducted Emissions (Subpart C)

The following table show a summary of the highest emissions of power line conducted emissions to the HOT and NATURAL conductor of the EUT power.

Manufacturer : *AMBIT Microsystems Corporation.*
Model No : *T60H625*
EUT : *Wireless PCMCIA Card*
Test Mode : *Channel No. 1*

Power Line Conducted Emissions (Class B)			
Conductor	Frequency (MHz)	Peak Amplitude (dBuV)	Limits (dBuV)
L1	0.48	37.23	47.9
	0.55	37.91	47.9
	0.82	44.12	47.9
	0.89	35.03	47.9
	0.97	36.80	47.9
	1.26	36.42	47.9
	1.54	36.60	47.9
L2	0.47	36.87	47.9
	0.54	36.69	47.9
	0.61	36.09	47.9
	0.69	35.91	47.9
	0.83	37.26	47.9
	0.96	37.63	47.9
	1.82	36.03	47.9

Notes : 1.L1: One end & Ground L2: The other end & Ground
2.Height of table on which the EUT was placed : 0.8 m.
3.The above test results are obtained under the normal condition.

2.6.3 Conducted Emissions (Subpart C)

The following table show a summary of the highest emissions of power line conducted emissions to the HOT and NATURAL conductor of the EUT power.

Manufacturer : *AMBIT Microsystems Corporation.*
 Model No : *T60H625*
 EUT : *Wireless PCMCIA Card*
 Test Mode : *Channel No. 6*

Power Line Conducted Emissions (Class B)			
Conductor	Frequency (MHz)	Peak Amplitude (dBuV)	Limits (dBuV)
L1	0.47	38.95	47.9
	0.55	37.69	47.9
	0.62	37.67	47.9
	0.81	44.93	47.9
	0.97	36.24	47.9
	1.26	37.03	47.9
	5.48	36.35	47.9
L2	0.47	36.15	47.9
	0.55	34.38	47.9
	0.69	35.25	47.9
	0.83	35.34	47.9
	0.96	36.74	47.9
	1.26	35.06	47.9
	1.54	34.87	47.9

Notes :
 1.L1: One end & Ground L2: The other end & Ground
 2.Height of table on which the EUT was placed : 0.8 m.
 3.The above test results are obtained under the normal condition.

2.6.4 Conducted Emissions (Subpart C)

The following table show a summary of the highest emissions of power line conducted emissions to the HOT and NATURAL conductor of the EUT power.

Manufacturer : *AMBIT Microsystems Corporation.*
 Model No : *T60H625*
 EUT : *Wireless PCMCIA Card*
 Test Mode : *Channel No. 11*

Power Line Conducted Emissions (Class B)			
Conductor	Frequency (MHz)	Peak Amplitude (dBuV)	Limits (dBuV)
L1	0.48	37.46	47.9
	0.62	37.70	47.9
	0.75	33.93	47.9
	0.81	40.45	47.9
	0.96	34.11	47.9
	5.48	31.94	47.9
	16.23	36.09	47.9
L2	0.48	38.98	47.9
	0.62	37.56	47.9
	0.76	33.43	47.9
	0.83	35.29	47.9
	0.97	33.52	47.9
	1.04	32.60	47.9
	4.11	30.21	47.9

Notes :
 1.L1: One end & Ground L2: The other end & Ground
 2.Height of table on which the EUT was placed : 0.8 m.
 3.The above test results are obtained under the normal condition.



III. Radiated Emissions Requirements

3.1 General Configuration:

Prior to open-field testing, the EUT was placed in a shielded enclosure and scanned at a close distance to determine its emission characteristics. The physical arrangement of the EUT was varied (within the scope of arrangements likely to be encountered in actual use) to determine the effect on the unit's emanations in amplitude, directivity, and frequency. The exact system configuration which produced the highest emissions was noted so it could be reproduced later during the open-field tests. This was done to ensure that the final measurements would demonstrate the worst-case interference potential of the EUT.

3.2 General Configuration:

Final radiation measurements were made on a three-meter, open-field test site. The EUT system was placed on a nonconductive turntable which is 0.8 meters height, top surface 1.0 x 1.5 meter. The spectrum was examined from 250 MHz to 4 GHz in order to cover the whole spectrum below 10th harmonic which could generate from the EUT. During the test, EUT was set to transmit continuously.

A nonconductive material surrounded the EUT to supporting the EUT for standing on three orthogonal planes. At each condition, the EUT was rotated 360 degrees, and the antenna was raised and lowered from one to four meters to find the maximum emission levels. Measurements were taken using both horizontal and vertical antenna polarization.

The field strength below 1 GHz was measured by EMCO Biconilog Antenna (model 3142) at 3 Meter and the SCHWARZBECK Double Ridged Guide Antenna (model BBHA9120D&9170) was used in frequencies 1 – 40 GHz at a distance of 1 meter. All test results were extrapolated to equivalent signal at 3 meters utilizing an inverse linear distance extrapolation Factor (20dB/decade).



MAX LIGHT

MEASUREMENT REPORT

Page: 20/70

Appropriate preamplifiers were used for improving sensitivity and precautions were taken to avoid overloading or desensitizing the spectrum analyzer. No post - detector video filters were used in the test.

The spectrum analyzer's 6 dB bandwidth was set to 1 MHz, and the analyzer was operated in the peak detection mode, for frequencies both below and up 1 GHz. The average levels were obtained by subtracting the duty cycle correction factor from the peak readings.

The following procedures were used to convert the emission levels measured in decibels referenced to 1 microvolt (dBuV) into field intensity in microvolts pre meter ($\mu\text{V}/\text{m}$).

The actual field intensity in decibels referenced to 1 microvolt in to field intensity in microvolts per meter (dBuV/m).

The actual field is intensity in referenced to 1 microvolt per meter (dBuV/m) is determined by algebraically adding the measured reading in dBuV, the antenna factor (dB), and cable loss (dB) and Subtracting the gain of preamplifier (dB) is auto calculate in spectrum analyzer.

$$(1) \text{ Amplitude (dBuV/m)} = \text{FI(dBuV)} + \text{AF(dBuV)} + \text{CL(dBuV)} - \text{Gain(dB)}$$

FI= Reading of the field intensity.

AF= Antenna factor.

CL= Cable loss.

P.S Amplitude is auto calculate in spectrum analyzer.

$$(2) \text{ Actual Amplitude (dBuV/m)} = \text{Amplitude (dBuV)} - \text{Dis(dB)}$$

The FCC specified emission limits were calculated according the EUT operating frequency and by following linear interpolation equations:

(1) For fundamental frequency :

Transmitter Output < +30dBm

(2) For spurious frequency :

Spurious emission limits = fundamental emission limit /10



3.2 Test Equipment List:

- A. HP 8591EM 9KHz-1.8GHz Spectrum Analyzer (S/N:73412A00230)
- B. HP 8447D Pre Amplifier (S/N:2944A08954)
- C. Agilent E4407B 9KHz-26.5GHz Spectrum Analyzer (S/N:A872JS02291)
- D. HP 8449B Pre Amplifier (S/N:1982901A91)
- E. SCHWARZBECK BBHA 9120D Biconilog Antenna (S/N:141S3)
- F. SCHWARZBECK BBHA 9170 Biconilog Antenna (S/N:192S5)

3.3 Test Configuration:



Front View of The Test Configuration



Rear View of The Test Configuration



3.4 Test condition:

EUT tested in accordance with the specifications given by the manufacturer , and exercised in the most unfavorable manner.

3.5 Radiated Emissions Limits:

<i>Frequency range (MHz)</i>	<i>Peak(dBuV)</i>
30 to 88	40
88 to 216	43.5
216 to 960	46
Above 960	54



3.6 Measurement Data Of Radiated Emissions:

3.6.1 Open Field Radiated Emissions (Subpart B)

The highest peak values of radiated emissions from the EUT at various antenna heights, antenna polarization, EUT orientation , etc. are recorded on the following

Manufacturer : *AMBIT Microsystems Corporation.*
Model No : *T60H625*
EUT : *Wireless PCMCIA Card*
Test Mode : *Run "Ping" Command*

Radiated Emissions (HORIZONTAL)					
Frequency (MHz)	Amplitude (dBuV/m)	Ant. (m)	Table (Degree)	Limits(Class B) (dBuV/m)	Margin (dB)
124.45	32.78	2	150	43.5	-10.72
160.85	34.87	2.5	300	43.5	-8.63
191.99	35.23	1.5	360	43.5	-8.27
198.95	38.97	1	320	43.5	-4.53
217.09	32.92	2	230	46	-13.08
294.78	40.18	2.5	100	46	-5.82
325.66	38.71	1.5	230	46	-7.29
456.02	38.34	2.5	340	46	-7.66
589.12	33.02	2	120	46	-12.98
696.78	37.88	1.5	230	46	-8.12
746.67	31.42	2	300	46	-14.58

- Notes :
- 1.Margin= Amplitude - Limits
 - 2.Distance of Measurement : 3 Meter (30-1000MHz)
 - 3.Height of table for EUT placed: 0.8 Meter.
 - 4.ANT= Antenna height.
 - 5.Amplitude= Reading Amplitude -Amplifier gain+Cable loss
+Antenna factor
(Auto calculate in spectrum analyzer)



3.6.2 Open Field Radiated Emissions (Subpart B)

The highest peak values of radiated emissions from the EUT at various antenna heights, antenna polarization, EUT orientation , etc. are recorded on the following.

Manufacturer : *AMBIT Microsystems Corporation.*
Model No : *T60H625*
EUT : *Wireless PCMCIA Card*
Test Mode : *Run "Ping" Command*

Radiated Emissions (VERTICAL)					
Frequency (MHz)	Amplitude (dBuV/m)	Ant. (m)	Table (Degree)	Limits(Class B) (dBuV/m)	Margin (dB)
47.99	35.76	1	300	40	-4.24
108.66	32.92	1.5	270	43.5	-10.58
124.44	39.28	1.5	190	43.5	-4.22
180.22	33.62	1	360	43.5	-9.88
194.73	33.02	1.5	340	43.5	-10.48
195.38	38.66	1.5	120	43.5	-4.84
199.97	31.76	1	360	43.5	-11.74
200.45	33.87	1	300	43.5	-9.63
216.00	34.88	2	250	46	-11.12
298.50	39.30	1.5	220	46	-6.70
456.00	33.39	1	90	46	-12.61

- Notes :
- 1.Margin= Amplitude - Limits
 - 2.Distance of Measurement : 3 Meter (30-1000MHz)
 - 3.Height of table for EUT placed: 0.8 Meter.
 - 4.ANT= Antenna height.
 - 5.Amplitude= Reading Amplitude -Amplifier gain+Cable loss +Antenna factor
(Auto calculate in spectrum analyzer)



3.6.3 Open Field Radiated Emissions (Subpart C)

The highest peak values of radiated emissions from the EUT at various antenna heights, antenna polarization, EUT orientation , etc. are recorded on the following

Manufacturer : *AMBIT Microsystems Corporation.*
Model No : *T60H625*
EUT : *Wireless PCMCIA Card*
Test Mode : *Channel No. 1*

Radiated Emissions (HORIZONTAL)								
Frequency (MHz)	Amplitude (dBuV/m)	Ant. (m)	Table (Degree)	Duty (dB)	Dist (dB)	Actual Amp (dBuV/m)	Limit (dBuV/m)	Margin (dB)
500.51	42.16	1	320	0	0	42.16	46.00	-3.84
641.60	41.76	1.5	210	0	0	41.76	46.00	-4.24
4824.31	60.21	1.2	300	0	9.54	50.67	74.00	-23.33
7237.87	56.56	1	230	0	9.54	47.02	74.00	-26.98
9649.02	55.21	1	100	0	9.54	45.67	74.00	-28.33
12060.08	55.89	1	190	0	9.54	46.35	74.00	-27.65
14472.23	56.09	1	310	0	9.54	46.55	74.00	-27.45

- Notes :
- 1.Margin= Amplitude - Limits
 - 2.Distance of Measurement : 3 Meter (30-1000MHz)
 - 3.Height of table for EUT placed: 0.8 Meter.
 - 4.ANT= Antenna height.
 - 5.Duty= Duty cycle correction factor.
 - 6.Dis= Distance extrapolation factor.
 - 7.Amplitude= Reading Amplitude - Amplifier gain+Cable loss +Antenna factor
(Auto calculate in spectrum analyzer)
 - 8.Actual Amp= Amplitude - Duty - Dis.



3.6.4 Open Field Radiated Emissions (Subpart C)

The highest peak values of radiated emissions from the EUT at various antenna heights, antenna polarization, EUT orientation , etc. are recorded on the following.

Manufacturer : *AMBIT Microsystems Corporation.*
Model No : *T60H625*
EUT : *Wireless PCMCIA Card*
Test Mode : *Channel No. 1*

Radiated Emissions (VERTICAL)								
Frequency (MHz)	Amplitude (dBuV/m)	Ant. (m)	Table (Degree)	Duty (dB)	Dist (dB)	Actual Amp (dBuV/m)	Limit (dBuV/m)	Margin (dB)
124.44	38.99	1	360	0	0	38.99	46.00	-7.01
195.43	37.51	1.5	280	0	0	37.51	46.00	-8.49
4824.32	57.43	1	360	0	9.54	47.89	74.00	-26.11
7237.87	55.23	1	210	0	9.54	45.69	74.00	-28.31
9649.02	55.01	1	180	0	9.54	45.47	74.00	-28.53
12060.08	54.56	1	220	0	9.54	45.02	74.00	-28.98
14472.23	55.44	1	300	0	9.54	45.90	74.00	-28.10

- Notes :
- 1. Margin= Amplitude - Limits
 - 2. Distance of Measurement : 3 Meter (30-1000MHz)
 - 3. Height of table for EUT placed: 0.8 Meter.
 - 4. ANT= Antenna height.
 - 5. Duty= Duty cycle correction factor.
 - 6. Dis= Distance extrapolation factor.
 - 7. Amplitude= Reading Amplitude - Amplifier gain+Cable loss +Antenna factor
(Auto calculate in spectrum analyzer)
 - 8. Actual Amp= Amplitude - Duty - Dis.



3.6.5 Open Field Radiated Emissions (Subpart C)

The highest peak values of radiated emissions from the EUT at various antenna heights, antenna polarization, EUT orientation , etc. are recorded on the following

Manufacturer : *AMBIT Microsystems Corporation.*
Model No : *T60H625*
EUT : *Wireless PCMCIA Card*
Test Mode : *Channel No. 6*

Radiated Emissions (HORIZONTAL)								
Frequency (MHz)	Amplitude (dBuV/m)	Ant. (m)	Table (Degree)	Duty (dB)	Dist (dB)	Actual Amp (dBuV/m)	Limit (dBuV/m)	Margin (dB)
500.51	42.54	1	330	0	0	42.54	46.00	-3.46
641.60	42.09	1.5	200	0	0	42.09	46.00	-3.91
4874.53	62.54	1	340	0	9.54	53.00	74.00	-21.00
7311.09	57.56	1	290	0	9.54	48.02	74.00	-25.98
9748.76	55.32	1	120	0	9.54	45.78	74.00	-28.22
12185.32	56.22	1	190	0	9.54	46.68	74.00	-27.32
14621.22	55.93	1	320	0	9.54	46.39	74.00	-27.61

- Notes :
- 1. Margin= Amplitude - Limits
 - 2. Distance of Measurement : 3 Meter (30-1000MHz)
 - 3. Height of table for EUT placed: 0.8 Meter.
 - 4. ANT= Antenna height.
 - 5. Duty= Duty cycle correction factor.
 - 6. Dis= Distance extrapolation factor.
 - 7. Amplitude= Reading Amplitude - Amplifier gain+Cable loss +Antenna factor
(Auto calculate in spectrum analyzer)
 - 8. Actual Amp= Amplitude - Duty - Dis.



3.6.6 Open Field Radiated Emissions (Subpart C)

The highest peak values of radiated emissions from the EUT at various antenna heights, antenna polarization, EUT orientation , etc. are recorded on the following.

Manufacturer : *AMBIT Microsystems Corporation.*
Model No : *T60H625*
EUT : *Wireless PCMCIA Card*
Test Mode : *Channel No. 6*

Radiated Emissions (VERTICAL)								
Frequency (MHz)	Amplitude (dBuV/m)	Ant. (m)	Table (Degree)	Duty (dB)	Dist (dB)	Actual Amp (dBuV/m)	Limit (dBuV/m)	Margin (dB)
124.44	39.12	1	360	0	0	39.12	46.00	-6.88
195.43	37.87	1.5	290	0	0	37.87	46.00	-8.13
4874.53	59.34	1	360	0	9.54	49.80	74.00	-24.20
7311.09	55.12	1	320	0	9.54	45.58	74.00	-28.42
9748.76	55.09	1	140	0	9.54	45.55	74.00	-28.45
12185.32	54.43	1	200	0	9.54	44.89	74.00	-29.11
14621.22	55.03	1	310	0	9.54	45.49	74.00	-28.51

- Notes :
- 1.Margin= Amplitude - Limits
 - 2.Distance of Measurement : 3 Meter (30-1000MHz)
 - 3.Height of table for EUT placed: 0.8 Meter.
 - 4.ANT= Antenna height.
 - 5.Duty= Duty cycle correction factor.
 - 6.Dis= Distance extrapolation factor.
 - 7.Amplitude= Reading Amplitude - Amplifier gain+Cable loss +Antenna factor
(Auto calculate in spectrum analyzer)
 - 8.Actual Amp= Amplitude - Duty - Dis.



3.6.7 Open Field Radiated Emissions (Subpart C)

The highest peak values of radiated emissions from the EUT at various antenna heights, antenna polarization, EUT orientation , etc. are recorded on the following

Manufacturer : *AMBIT Microsystems Corporation.*
Model No : *T60H625*
EUT : *Wireless PCMCIA Card*
Test Mode : *Channel No. 11*

Radiated Emissions (HORIZONTAL)								
Frequency (MHz)	Amplitude (dBuV/m)	Ant. (m)	Table (Degree)	Duty (dB)	Dist (dB)	Actual Amp (dBuV/m)	Limit (dBuV/m)	Margin (dB)
500.48	41.93	1	320	0	0	41.93	46.00	-4.07
641.62	41.67	1.5	220	0	0	41.67	46.00	-4.33
4924.87	61.97	1.2	320	0	9.54	52.43	74.00	-21.57
7388.02	55.32	1	280	0	9.54	45.78	74.00	-28.22
9848.56	55.09	1	190	0	9.54	45.55	74.00	-28.45
12310.21	56.21	1	100	0	9.54	46.67	74.00	-27.33
14772.29	55.55	1	340	0	9.54	46.01	74.00	-27.99

- Notes :
- 1.Margin= Amplitude - Limits
 - 2.Distance of Measurement : 3 Meter (30-1000MHz)
 - 3.Height of table for EUT placed: 0.8 Meter.
 - 4.ANT= Antenna height.
 - 5.Duty= Duty cycle correction factor.
 - 6.Dis= Distance extrapolation factor.
 - 7.Amplitude= Reading Amplitude – Amplifier gain+Cable loss +Antenna factor
(Auto calculate in spectrum analyzer)
 - 8.Actual Amp= Amplitude – Duty – Dis.



MAX LIGHT

MEASUREMENT REPORT

3.6.8 Open Field Radiated Emissions (Subpart C)

The highest peak values of radiated emissions from the EUT at various antenna heights, antenna polarization, EUT orientation , etc. are recorded on the following.

Manufacturer : *AMBIT Microsystems Corporation.*
Model No : *T60H625*
EUT : *Wireless PCMCIA Card*
Test Mode : *Channel No. 11*

Radiated Emissions (VERTICAL)								
Frequency (MHz)	Amplitude (dBuV/m)	Ant. (m)	Table (Degree)	Duty (dB)	Dist (dB)	Actual Amp (dBuV/m)	Limit (dBuV/m)	Margin (dB)
124.45	39.56	1	340	0	0	39.56	46.00	-6.44
195.43	38.01	1	300	0	0	38.01	46.00	-7.99
4924.87	58.67	1	310	0	9.54	49.13	74.00	-24.87
7388.01	55.89	1	270	0	9.54	46.35	74.00	-27.65
9848.56	55.23	1	160	0	9.54	45.69	74.00	-28.31
12310.22	55.44	1	120	0	9.54	45.90	74.00	-28.10
14772.29	55.97	1	310	0	9.54	46.43	74.00	-27.57

- Notes :
- 1.Margin= Amplitude - Limits
 - 2.Distance of Measurement : 3 Meter (30-1000MHz)
 - 3.Height of table for EUT placed: 0.8 Meter.
 - 4.ANT= Antenna height.
 - 5.Duty= Duty cycle correction factor.
 - 6.Dis= Distance extrapolation factor.
 - 7.Amplitude= Reading Amplitude - Amplifier gain+Cable loss +Antenna factor
(Auto calculate in spectrum analyzer)
 - 8.Actual Amp= Amplitude - Duty - Dis.



IV. Maximum Conducted Output Power Requirements

4.1 Test Condition & Setup :

The tests below are run with the EUT's transmitter set at high power in TDD mode. A RJ-45 port from a computer to the EUT is needed to force selection of output power level and channel number. While testing, EUT was set to transmit continuously. Remove the Subjective device's antenna and connect the RF output port to spectrum analyzer. The maximum peak output power shall not exceed 1 watt.

Use a direct connection between the antenna port of transmitter and the spectrum Analyzer, for prevent the spectrum analyzer input attenuation 40-50 dB. Set the RBW Bandwidth of the emission or use a channel power meter mode .

For antennas with gains of 6 dBi or less , maximum allowed transmitter output is 1 watt (+30 dBm). For antennas with gains greater than 6 dBi, transmitter output level must be decreased by an amount equal to $(\text{GAIN} - 6)/3$ dBm.

The antenna port of the EUT was connected to the input of a power meter. Power was read directly and cable loss correction was added to the reading to obtain power at the EUT antenna terminals.

4.2 Test Instruments Configuration:

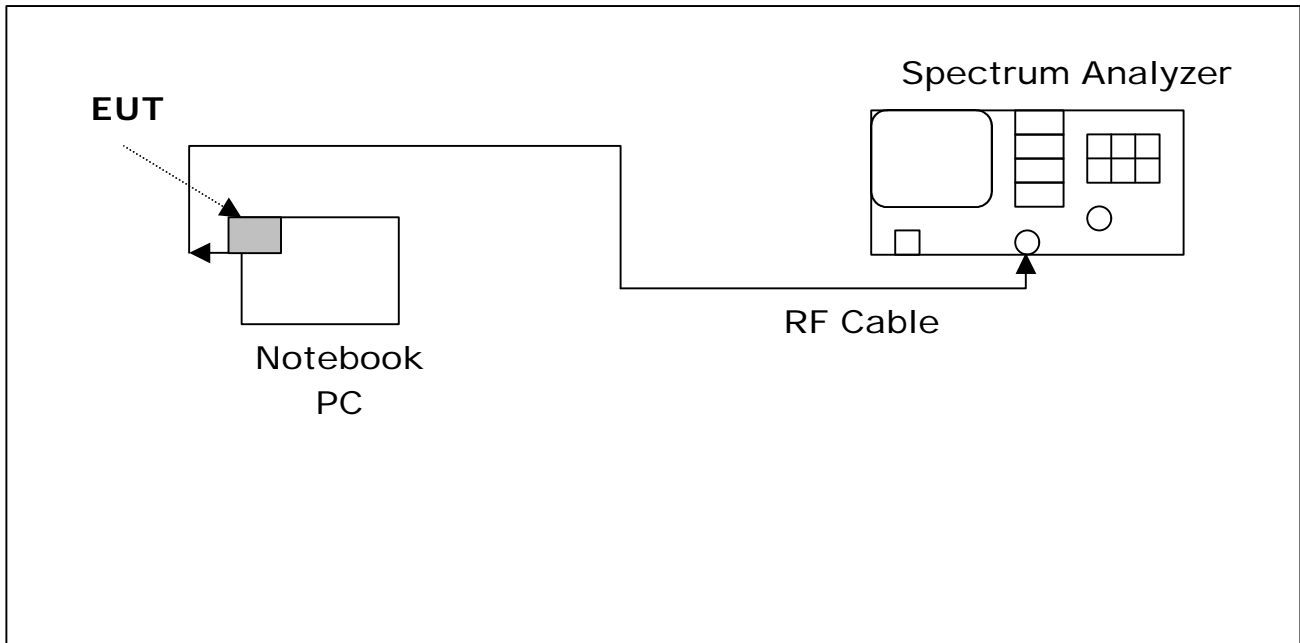

4.3 Test Equipment List:

- A. Agilent E4407B 9KHz-26.5GHz Spectrum Analyzer (S/N:A872JS02291)
- B. HP 8449B Pre Amplifier (S/N:1982901A91)
- E. Shielded Room (MLT-SR1)

4.4 Test Result:

Frequency (MHz)	Output(dBm)	Required Limit
2412	13.50	<30dBm
2437	12.79	<30dBm
2462	13.16	<30dBm

Note :Test Graphs See next page.



MAX LIGHT

MEASUREMENT REPORT

CH1

Sep 11 12:01:15

Trc A(2)

REF 25.1 dBm

*ATT 40dB A_max B_view

10dB/

Posi

Posi

Max Hold

POWER AVG

Marker

2.41340 GHz

A

#100

5.10

dBm

AVG A ▶

DL 13.5 dBm

Min Hold

A

Store

A to B

Channel Power

100/100

Trc Menu

13.50 dBm

A / B

CENTER 2.41120 GHz

SPAN 50.0 MHz

2/2, more ▶

*RBW 1 MHz

*VBW 1 MHz

*SWP 100 ms



MAX LIGHT

MEASUREMENT REPORT

CH6

Sep 11 12:07:39

REF 25.1 dBm

*ATT 40dB A_max B_view

10dB/

Posi Posi

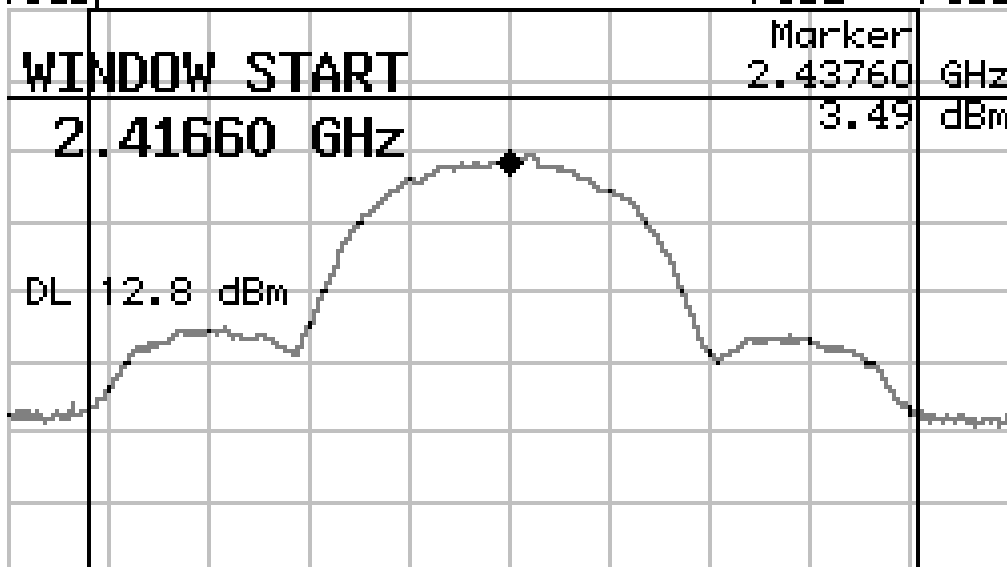

Trc A(2)

Max Hold

A

AVG A ▶

Min Hold

A

Store
A to B

Channel Power 100/100

12.79 dBm

Trc Menu

A / B

CENTER 2.43760 GHz

SPAN 50.0 MHz

2/2, more▶

*RBW 1 MHz

*VBW 1 MHz

*SWP 100 ms



MAX LIGHT

MEASUREMENT REPORT

CH11

Sep 11 12:11:28

Trc A(2)

REF 25.1 dBm

*ATT 40dB A_max B_view

10dB/

Posi

Posi

Max Hold

POWER AVG

Marker

2.46230 GHz

4.10 dBm

A

#100

AVG A ▶

DL 13.2 dBm

Min Hold

A

Store

A to B

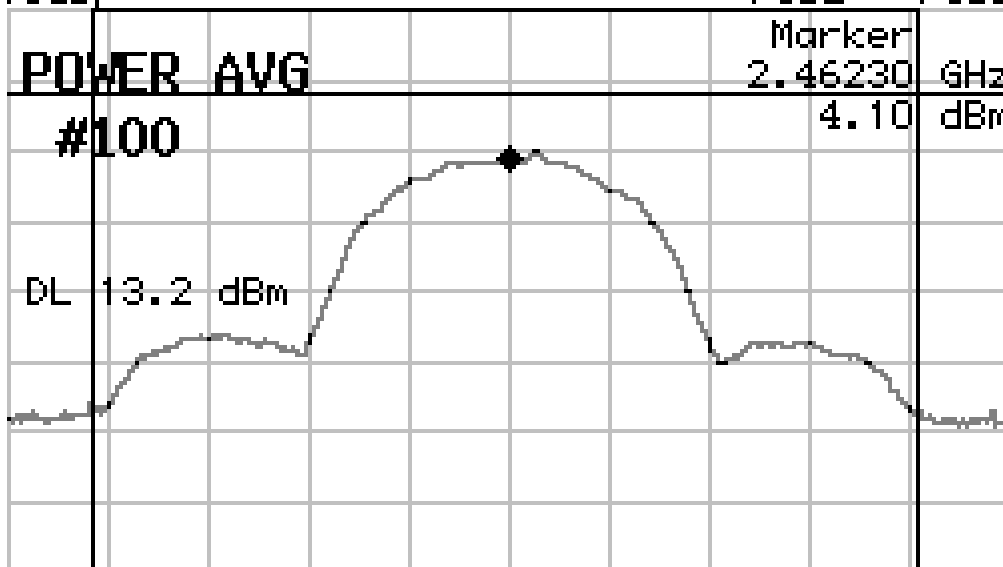

Channel Power	100/100
13.16 dBm	

Trc Menu

A / B

CENTER 2.46230 GHz

SPAN 50.0 MHz

2/2, more▶

*RBW 1 MHz

*VBW 1 MHz

*SWP 100 ms

V. Minimum 6dB RF Bandwidth Requirements

5.1 Test Condition & Setup :

The antenna port of the EUT was connected to the input of a spectrum analyzer. Analyzer RES BW was set to 100 kHz. For each RF output channel investigated, the spectrum analyzer center frequency was set to the channel carrier. A PEAK output reading was taken, a DISPLAY line was drawn 6 dB lower than PEAK level. The 6 dB bandwidth was determined from where the channel output spectrum intersected the display line.

The test was performed at 3 channels (Channel 1, 6,11)

5.2 Test Instruments Configuration:

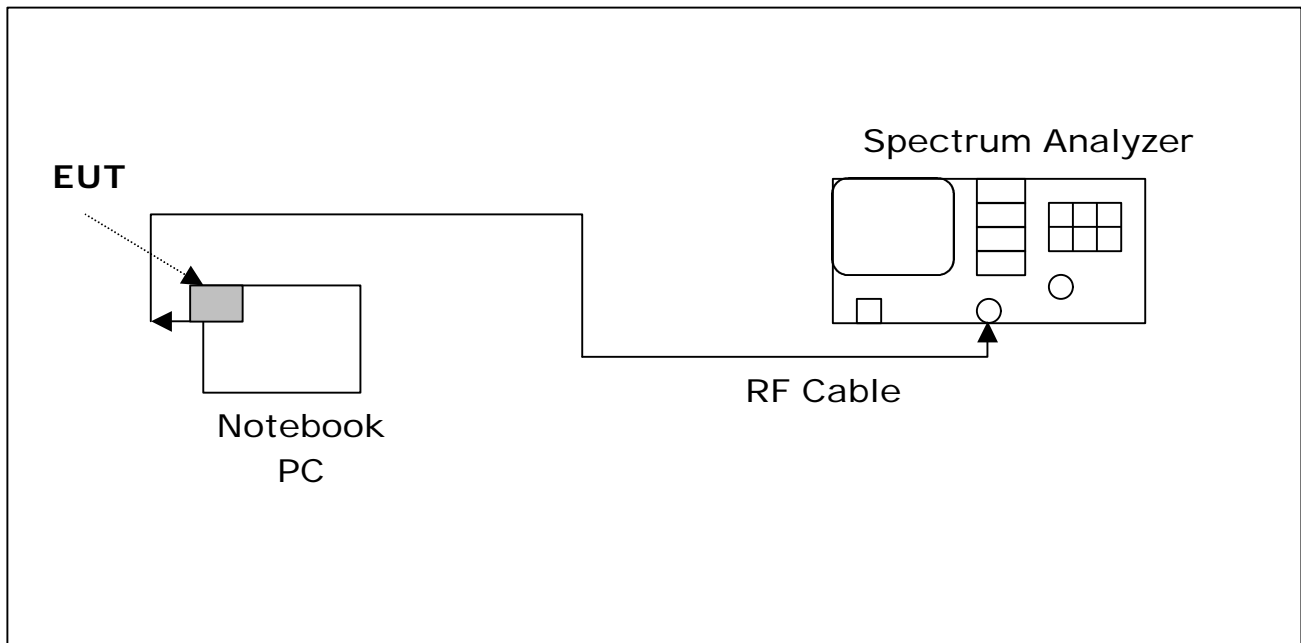



5.3 Test Equipment List:

- A. Agilent E4407B 9KHz-26.5GHz Spectrum Analyzer (S/N:A872JS02291)
- B. HP 8449B Pre Amplifier (S/N:1982901A91)
- E. Shielded Room (MLT-SR1)

5.4 Test Result:

Frequency (MHz)	Min. 6dB Bandwidth (MHz)	Required Limit
2412	12.40	>500KHz
2437	12.60	>500KHz
2462	12.50	>500KHz

Note :Test Graphs See next page.



MAX LIGHT

MEASUREMENT REPORT

CH1 Sep 11 12:38:44
REF 15.0 dBm *ATT 50dB A_max B_view
10dB/ Posi Posi

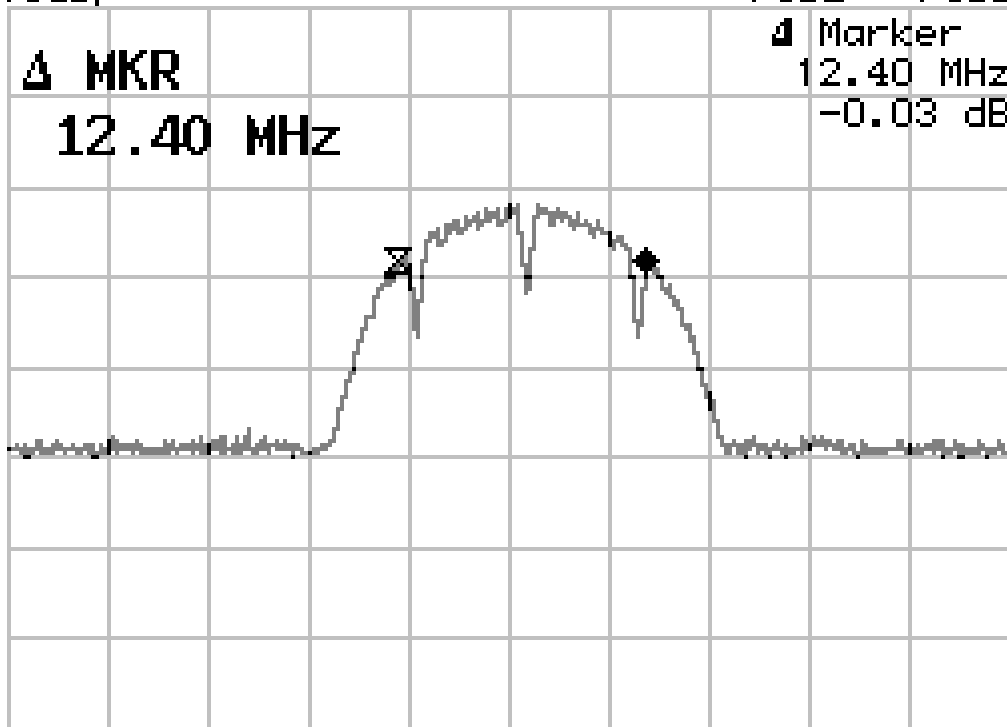

- Marker(1)

- Normal Marker

- Delta Marker

- Peak Menu ▶

- Sig Track ON /OFF

- Sound ▶

- Marker Off

CENTER 2.41140 GHz SPAN 50.0 MHz
*RBW 100 kHz *VBW 100 kHz *SWP 50 ms

1/2, more▶



MAX LIGHT

MEASUREMENT REPORT

CH6 Sep 11 12:36:05
REF 15.0 dBm *ATT 50dB A_max B_view
10dB/ Posi Posi

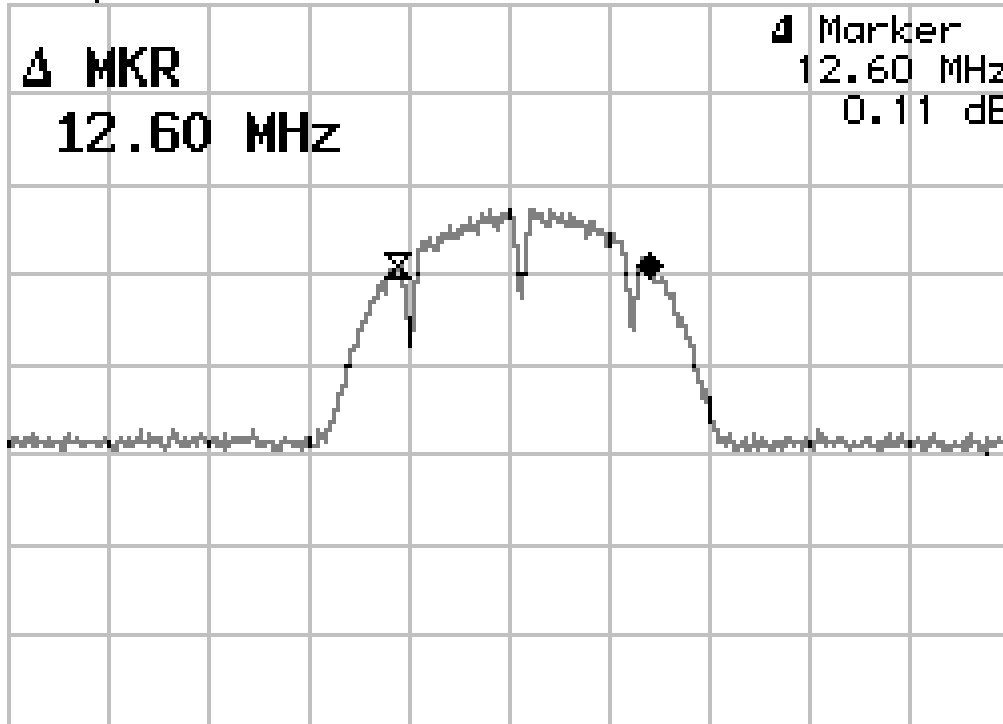

- Marker(1)

- Normal Marker

- Delta Marker

- Peak Menu ▶

- Sig Track ON /OFF

- Sound ▶

- Marker Off

CENTER 2.43670 GHz SPAN 50.0 MHz
*RBW 100 kHz *VBW 100 kHz *SWP 50 ms

1/2, more▶



MAX LIGHT

MEASUREMENT REPORT

CH11 Sep 11 12:29:22
REF 15.0 dBm *ATT 50dB A_max B_view
10dB/ Posi Posi

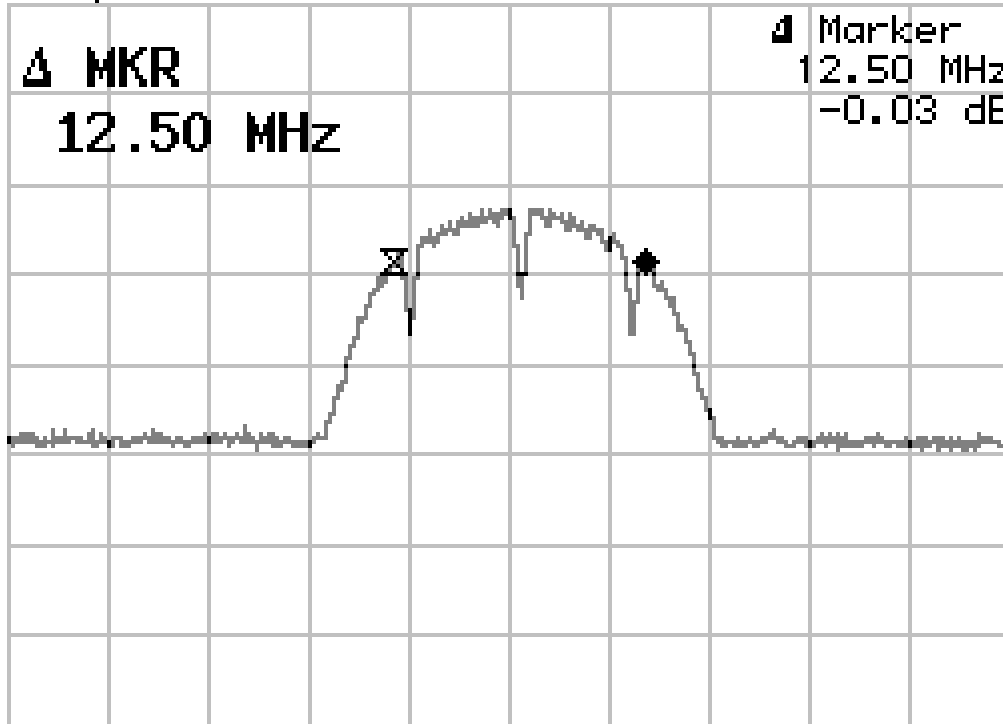

- Marker(1)
- Normal Marker
- Delta Marker
- Peak Menu ▶
- Sig Track ON /OFF
- Sound ▶
- Marker Off

CENTER 2.46170 GHz SPAN 50.0 MHz
*RBW 100 kHz *VBW 100 kHz *SWP 50 ms

1/2, more▶

VI. Maximum Power Density Requirements

6.1 Test Condition & Setup :

The spectrum analyzer RES BW was set to 3 kHz. The START and STOP frequencies were set to the band edges of the maximum output passband. If there is no clear maximum amplitude in any given portion of the band, it may be necessary to make measurements at a number of bands defined by several START and STOP frequency pairs. The specification calls for a 1 second interval at each 3 kHz bandwidth; total SWEEP TIME is calculated as follows:

$$\text{SWEEP TIME (SEC)} = (\text{Fstop, kHz} - \text{Fstart, kHz}) / 3 \text{ kHz}$$

Antenna output of the EUT was coupled directly to spectrum analyzer; if an external attenuator and/or cable was used, these losses are compensated for with the analyzer OFFSET function.

6.2 Test Instruments Configuration:

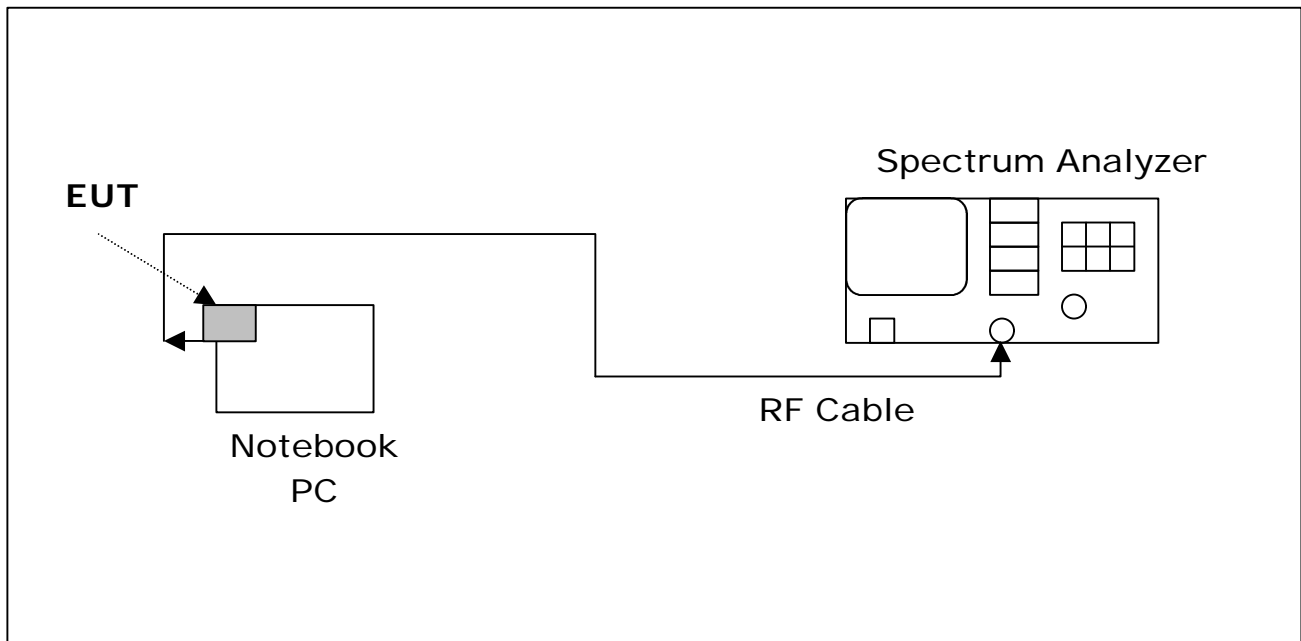



6.3 Test Equipment List:

- A. Agilent E4407B 9KHz-26.5GHz Spectrum Analyzer (S/N:A872JS02291)
- B. HP 8449B Pre Amplifier (S/N:1982901A91)
- E. Shielded Room (MLT-SR1)

6.4 Test Result:

Frequency (MHz)	Power Density (dBm)	Required Limit
2412	-12.81	<8dBm
2437	-14.64	<8dBm
2462	-13.64	<8dBm

Note :

1. Frequency Span= 600 kHz
2. Sweep Time = Frequency Span/3 kHz=200secs
3. Test Graphs See next page.



MAX LIGHT

MEASUREMENT REPORT

CH1 Sep 18 15:32:07
REF 10.0 dBm *ATT 50dB A_wrt B_view
10dB/ Posi Posi

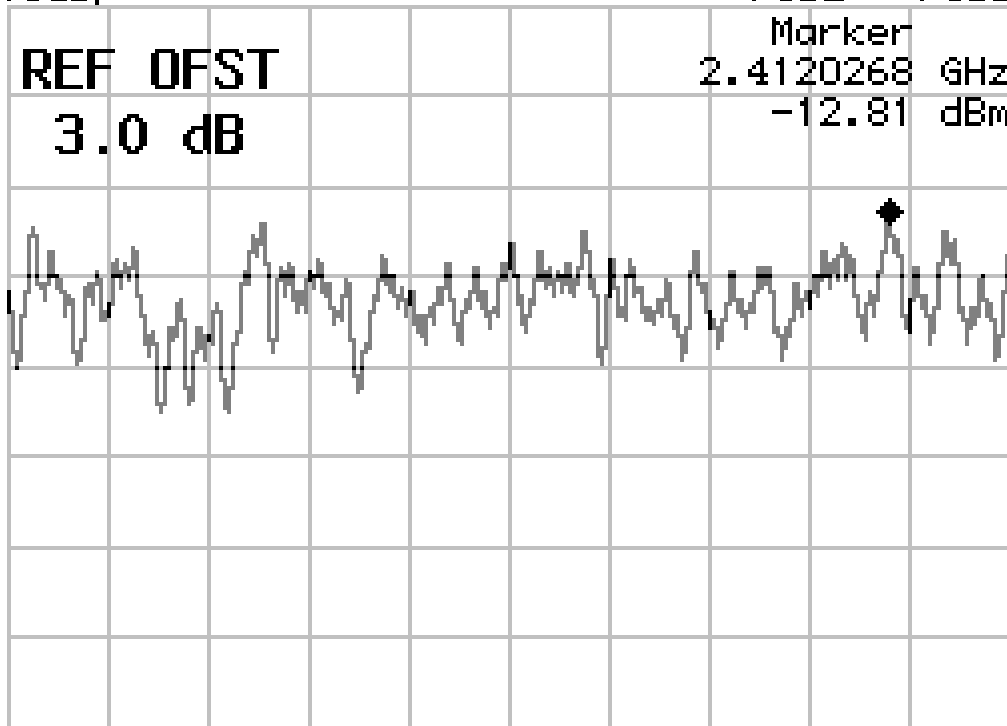

REF OFST
3.0 dB

Marker
2.4120268 GHz
-12.81 dBm

Level

Ref Level

ATT
AUTO /MNL

dB/div ▶

Linear

Units ▶

Ref
Offset
ON /OFF

Input
50Ω /75Ω

CENTER 2.4118000 GHz SPAN 600 kHz
*RBW 3 kHz *VBW 10 kHz *SWP 200 s



MAX LIGHT

MEASUREMENT REPORT

CH6 Sep 18 15:40:54
REF 10.0 dBm *ATT 50dB A_view B_view
10dB/ Posi Posi

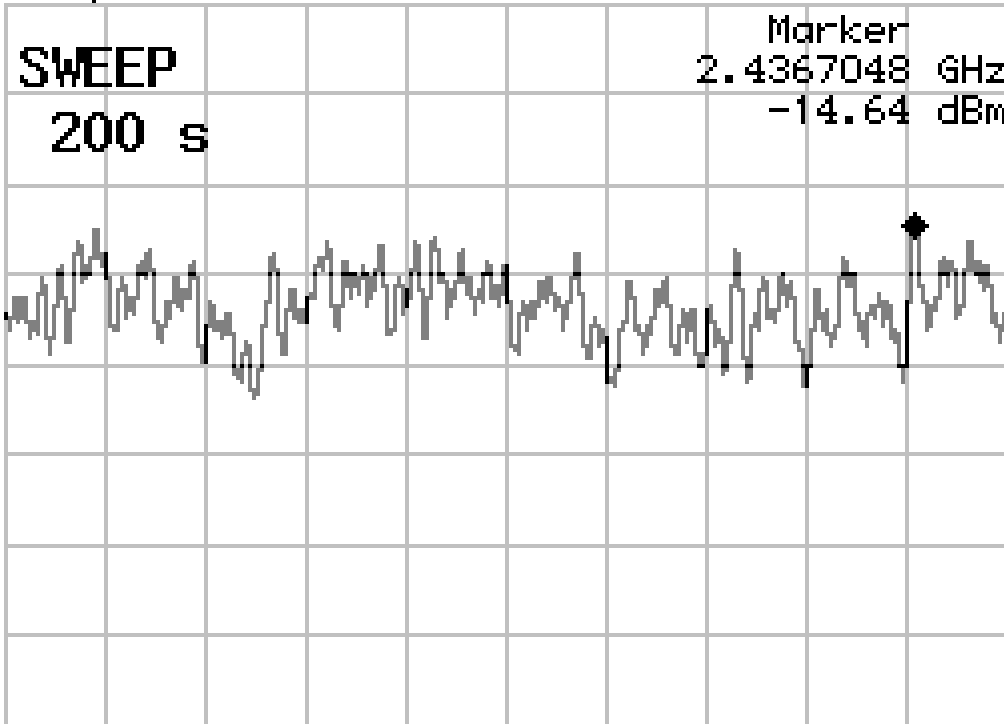

- Trc A(1)
- Write A
- View A
- Blank A
- Detector ▶
- Trc Menu
A / B

CENTER 2.4364600 GHz SPAN 600 kHz
*RBW 3 kHz *VBW 10 kHz *SWP 200 s

1/2, more ▶



MAX LIGHT

MEASUREMENT REPORT

CH11

Sep 18 15:49:57

REF 10.0 dBm
10dB/

*ATT 50dB A_view B_view
Posi Posi

Trc A(1)

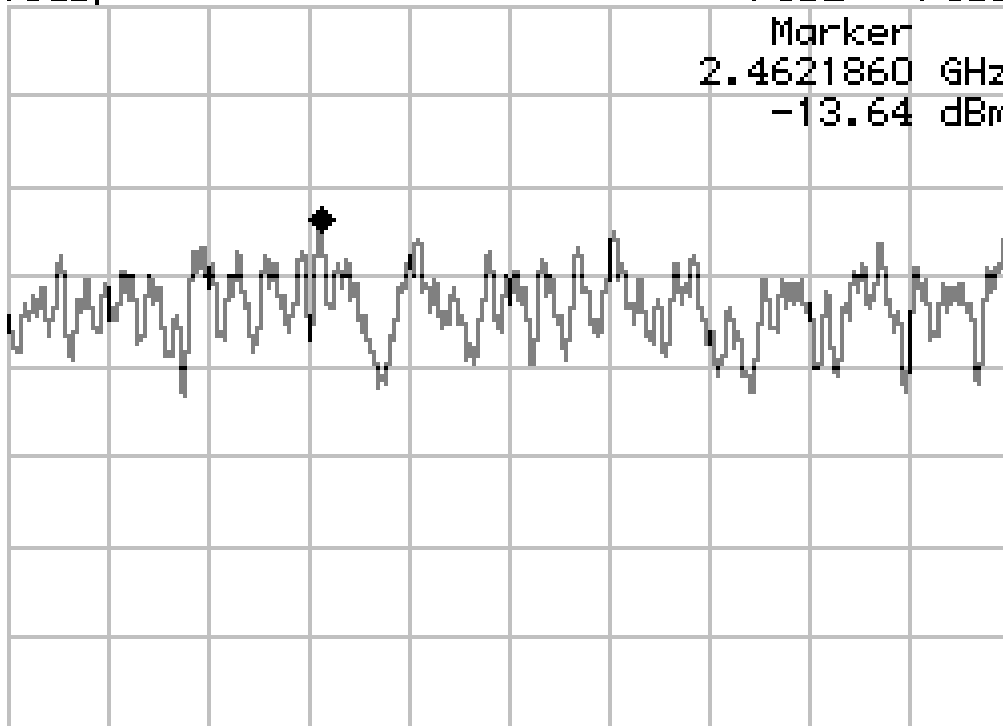

Write A

View A

Blank A

Detector ▶

Trc Menu
A / B

CENTER 2.4623000 GHz SPAN 600 kHz
*RBW 3 kHz *VBW 10 kHz *SWP 200 s

1/2, more ▶

VII. Out of Band Conducted Emissions Requirements

7.1 Test Condition & Setup :

In any 100 kHz bandwidth outside the EUT passband, the RF power produced by the modulation products of the spreading sequence, the information sequence, and the carrier frequency shall be at least 20 dB below that of the maximum in-band 100 kHz emission, antenna output of the EUT was coupled directly to spectrum analyzer; if an external attenuator and/or cable was used, these losses are compensated for with the analyzer OFFSET function.

All other types of emissions from the EUT shall meet the general limits for radiated frequencies outside the passband. the test was performed at 3 channels (Channel 1, 6,11)

7.2 Test Instruments Configuration:

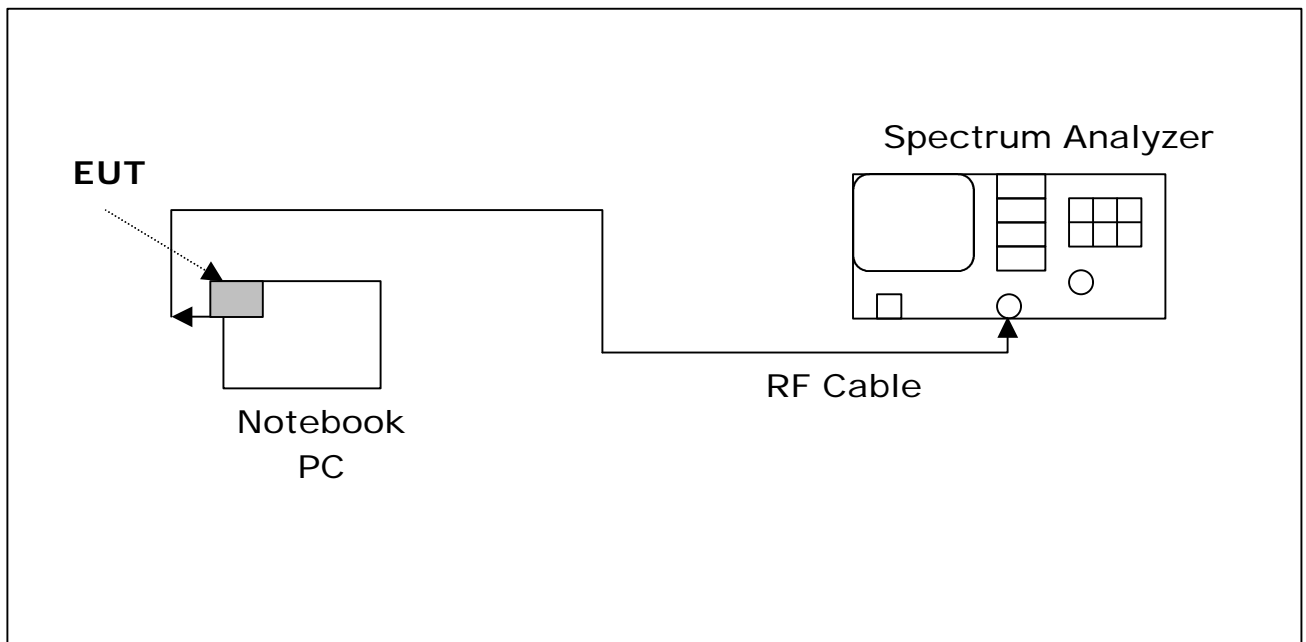



7.3 Test Equipment List:

- A. Agilent E4407B 9KHz-26.5GHz Spectrum Analyzer (S/N:A872JS02291)
- B. Shielded Room (MLT-SR1)

7.4 Test Result:

Refer to attached data sheets. Data shows out of band emissions are suppressed well below the -20 dBc minimum required by the Rules.

Note : Test Graphs See next page.



MAX LIGHT

MEASUREMENT REPORT

Channel 01 (1 of 5)

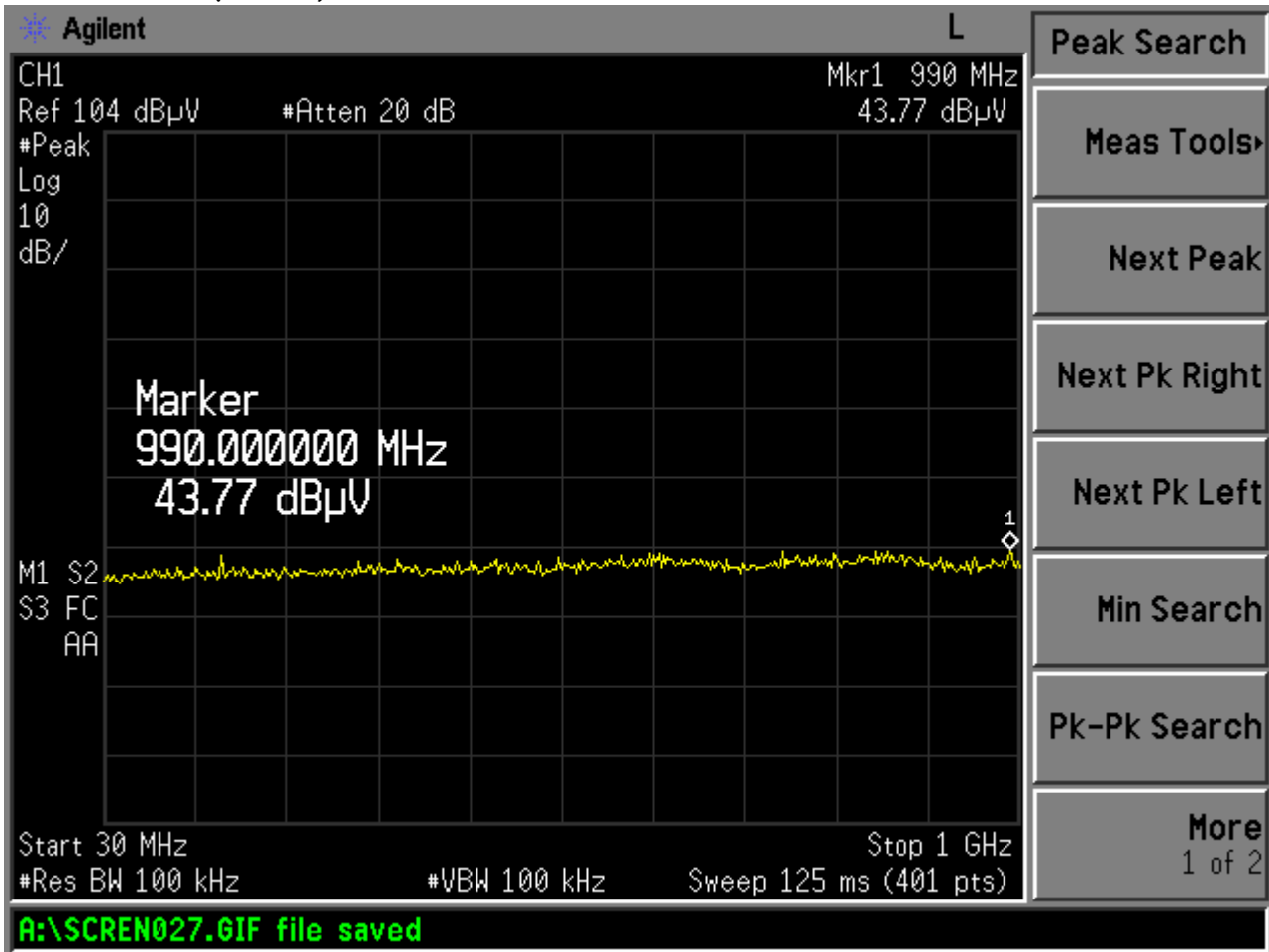



MAX LIGHT

MEASUREMENT REPORT

Channel 01 (2 of 5)

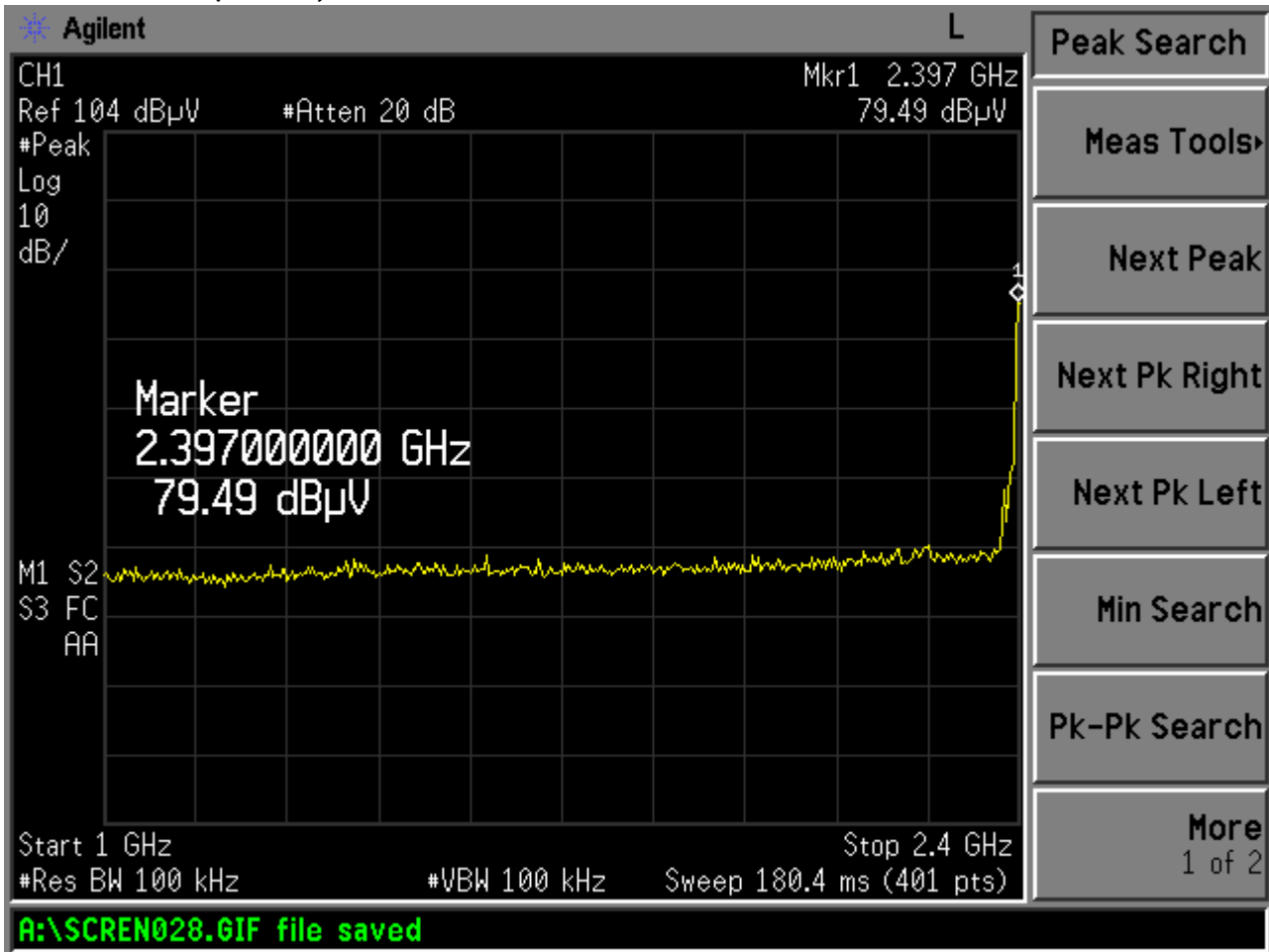

Channel 01 (3 of 5)

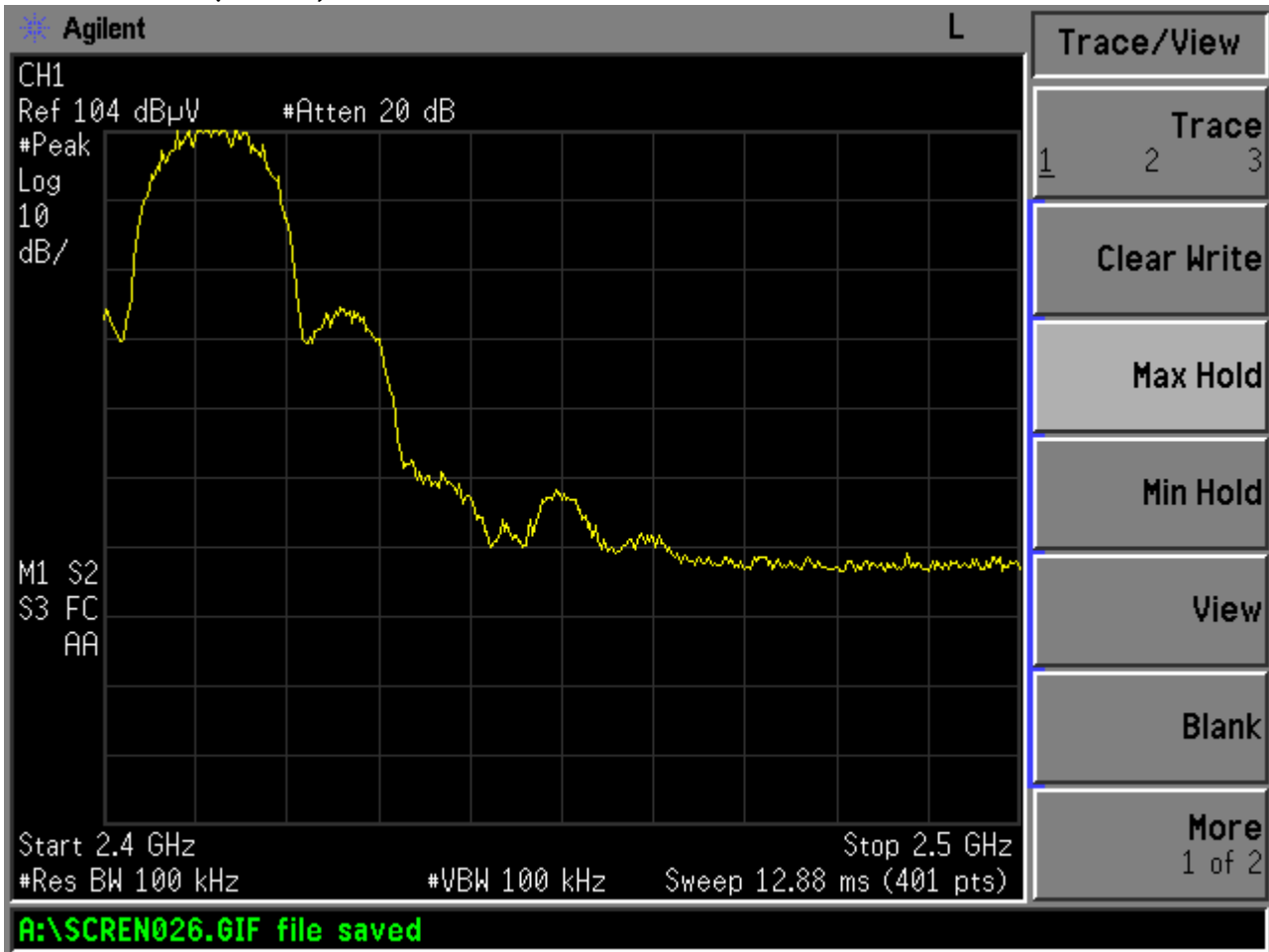



MAX LIGHT

MEASUREMENT REPORT

Channel 01 (4 of 5)

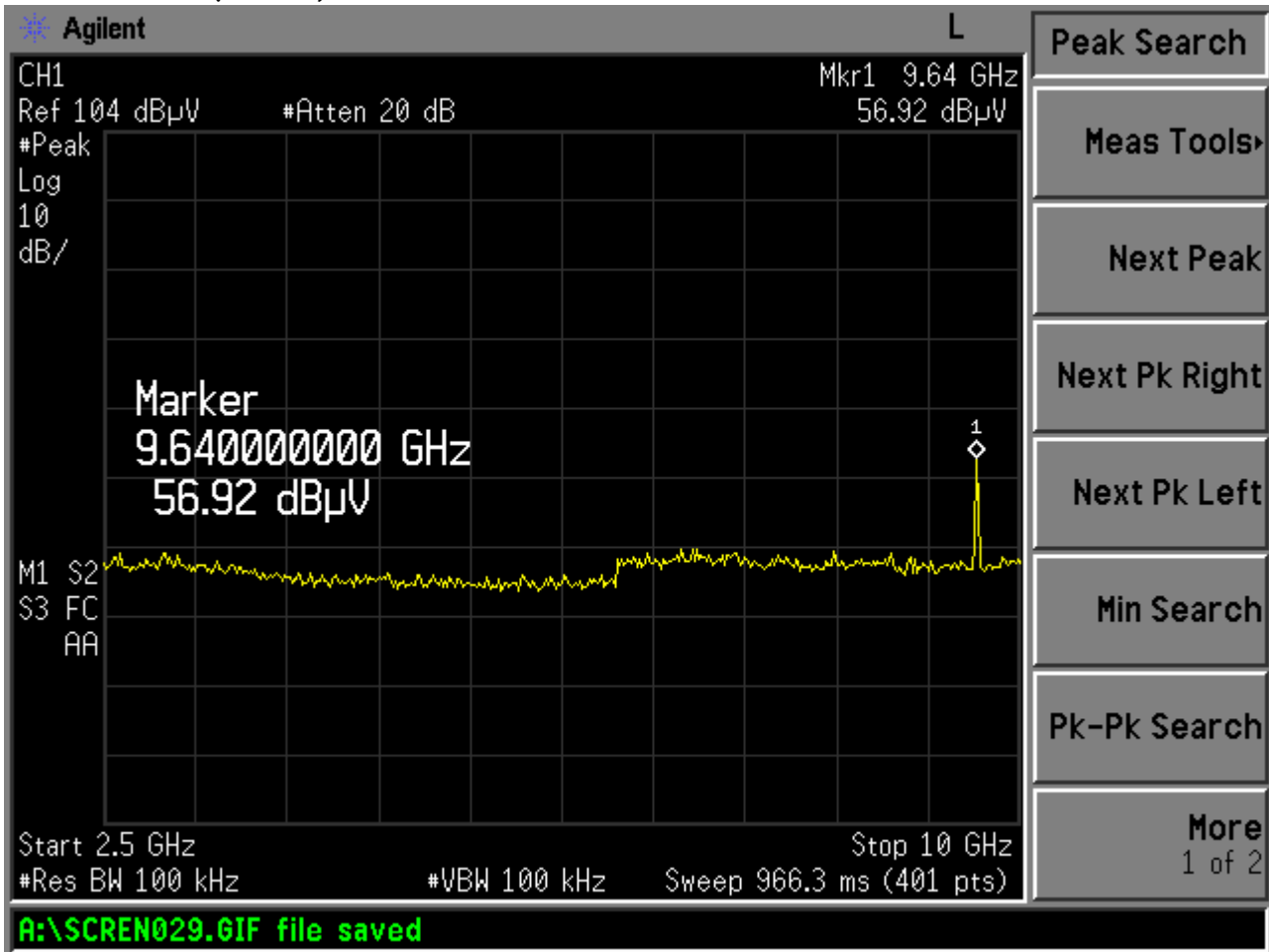



MAX LIGHT

MEASUREMENT REPORT

Channel 01 (5 of 5)

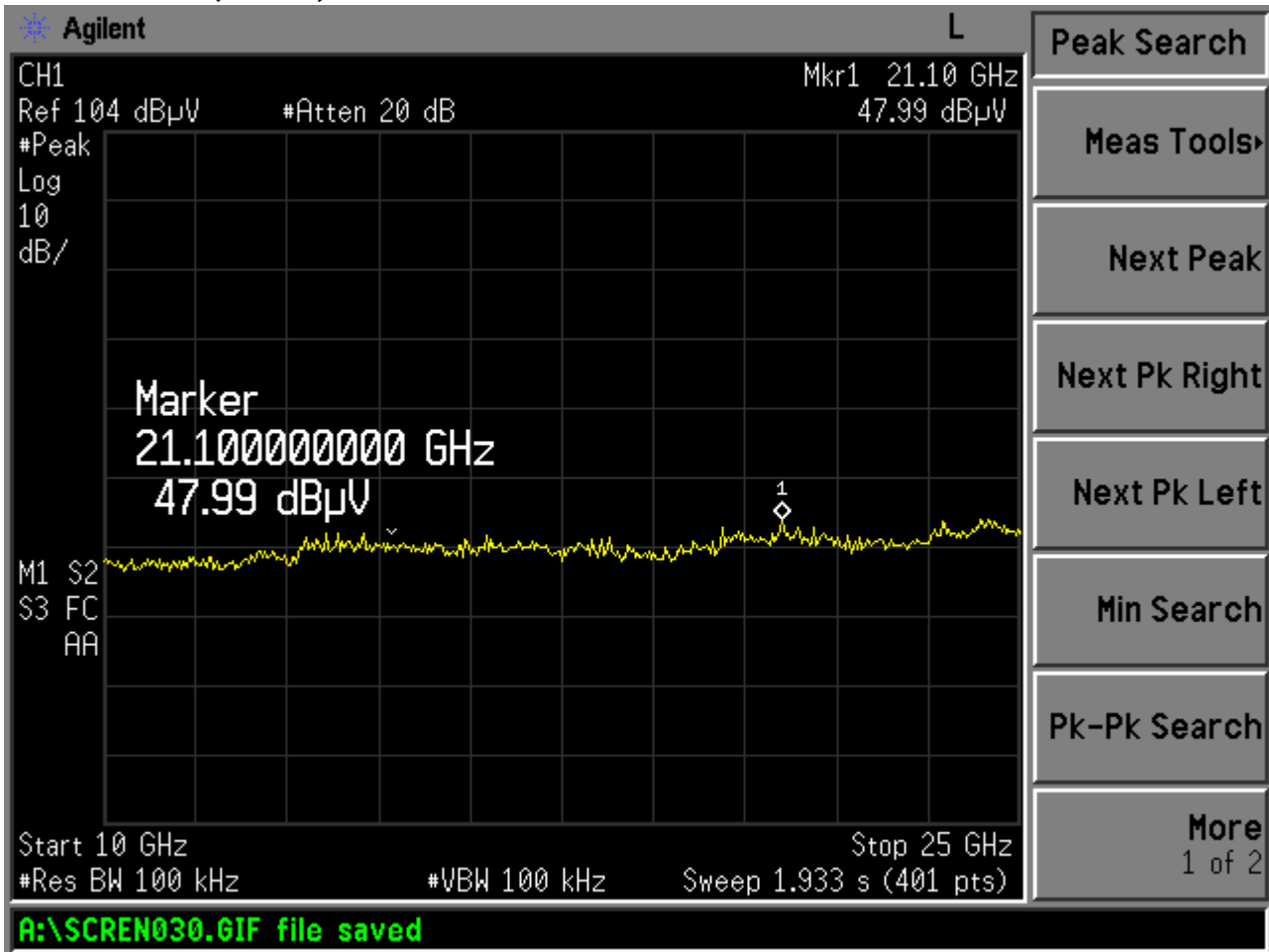



MAX LIGHT

MEASUREMENT REPORT

Channel 06 (1 of 5)

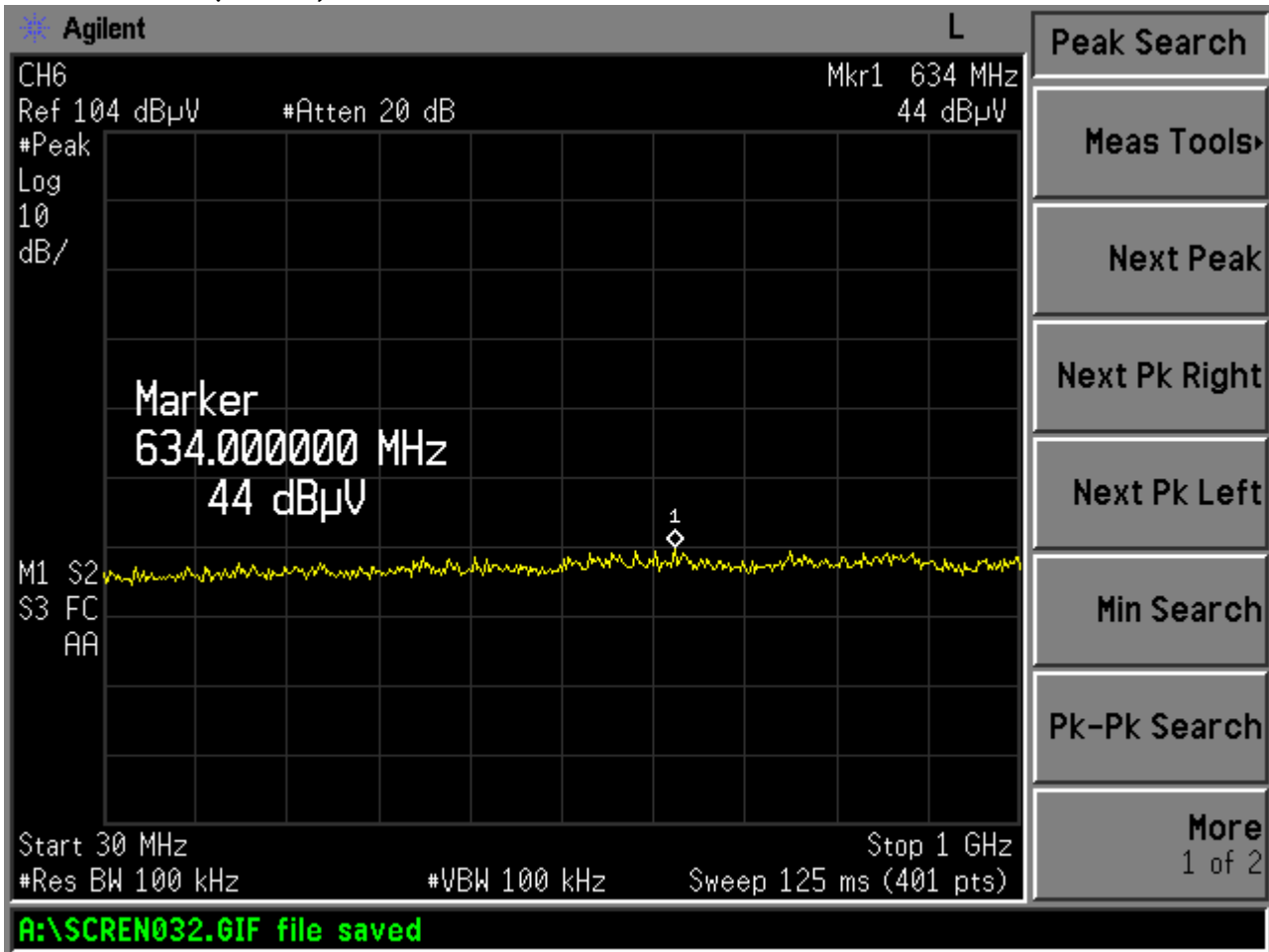



MAX LIGHT

MEASUREMENT REPORT

Channel 06 (2 of 5)

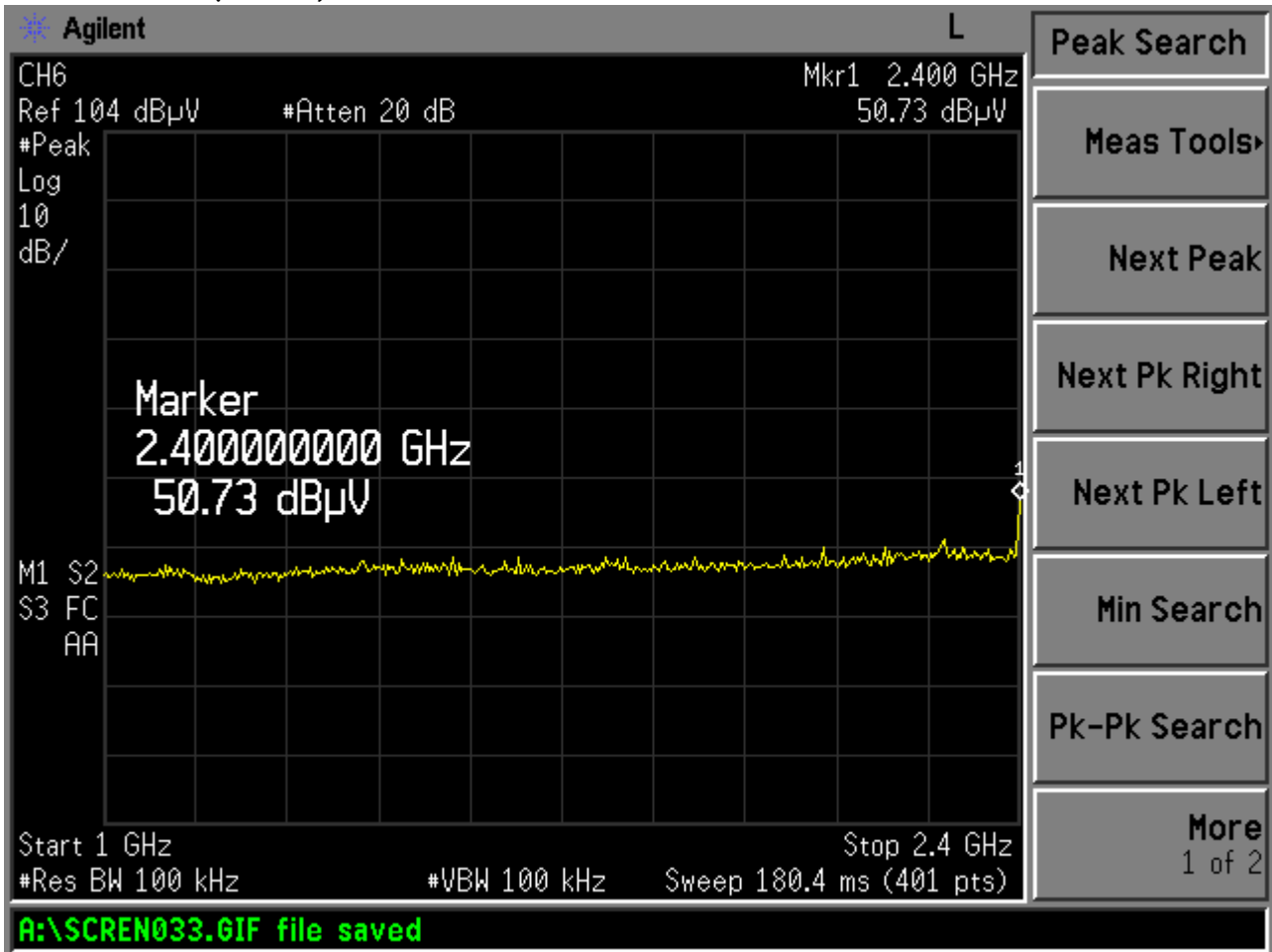

Channel 06 (3 of 5)





MAX LIGHT

MEASUREMENT REPORT

Channel 06 (4 of 5)

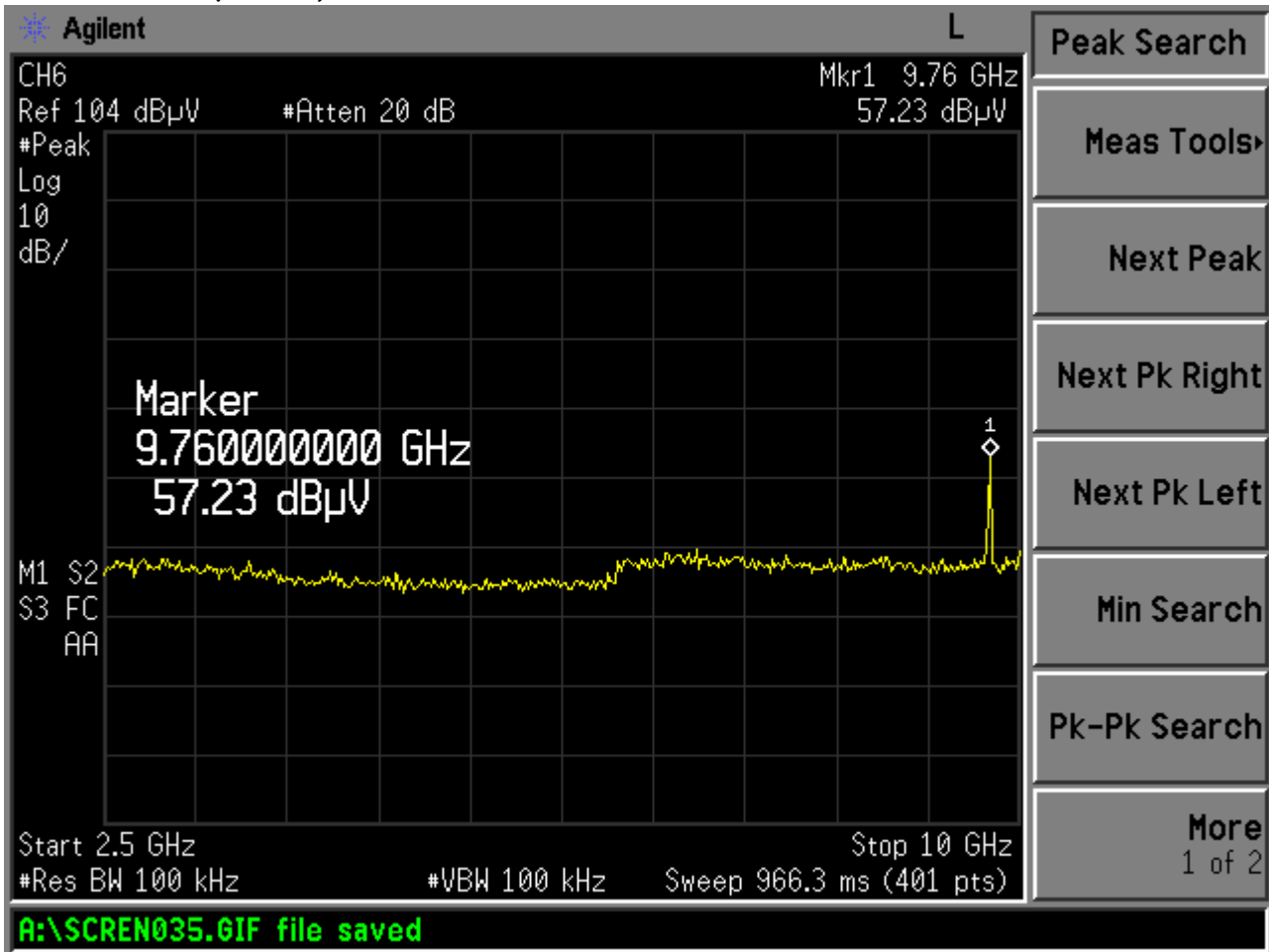



MAX LIGHT

MEASUREMENT REPORT

Channel 06 (5 of 5)

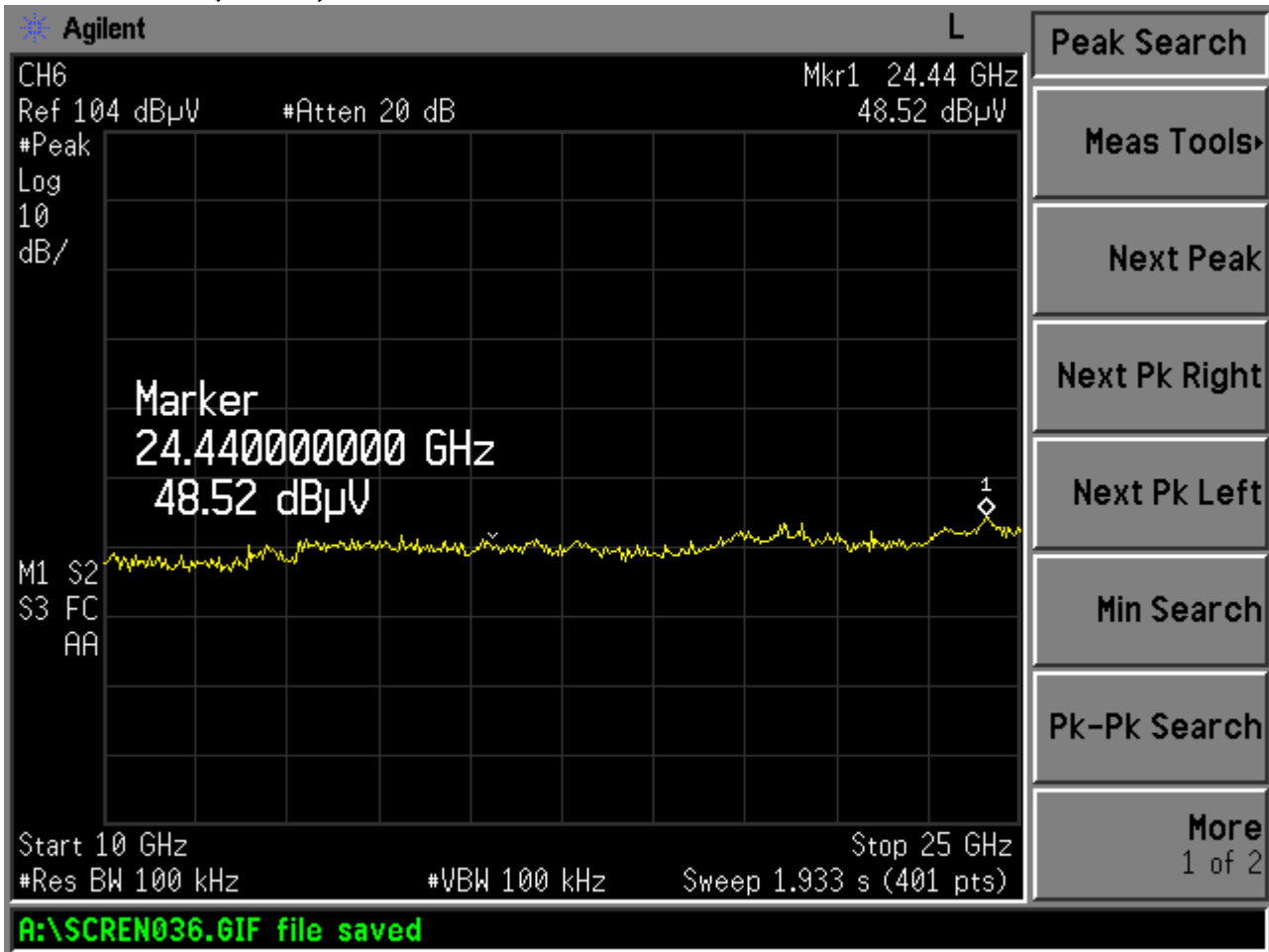



MAX LIGHT

MEASUREMENT REPORT

Channel 11 (1 of 5)

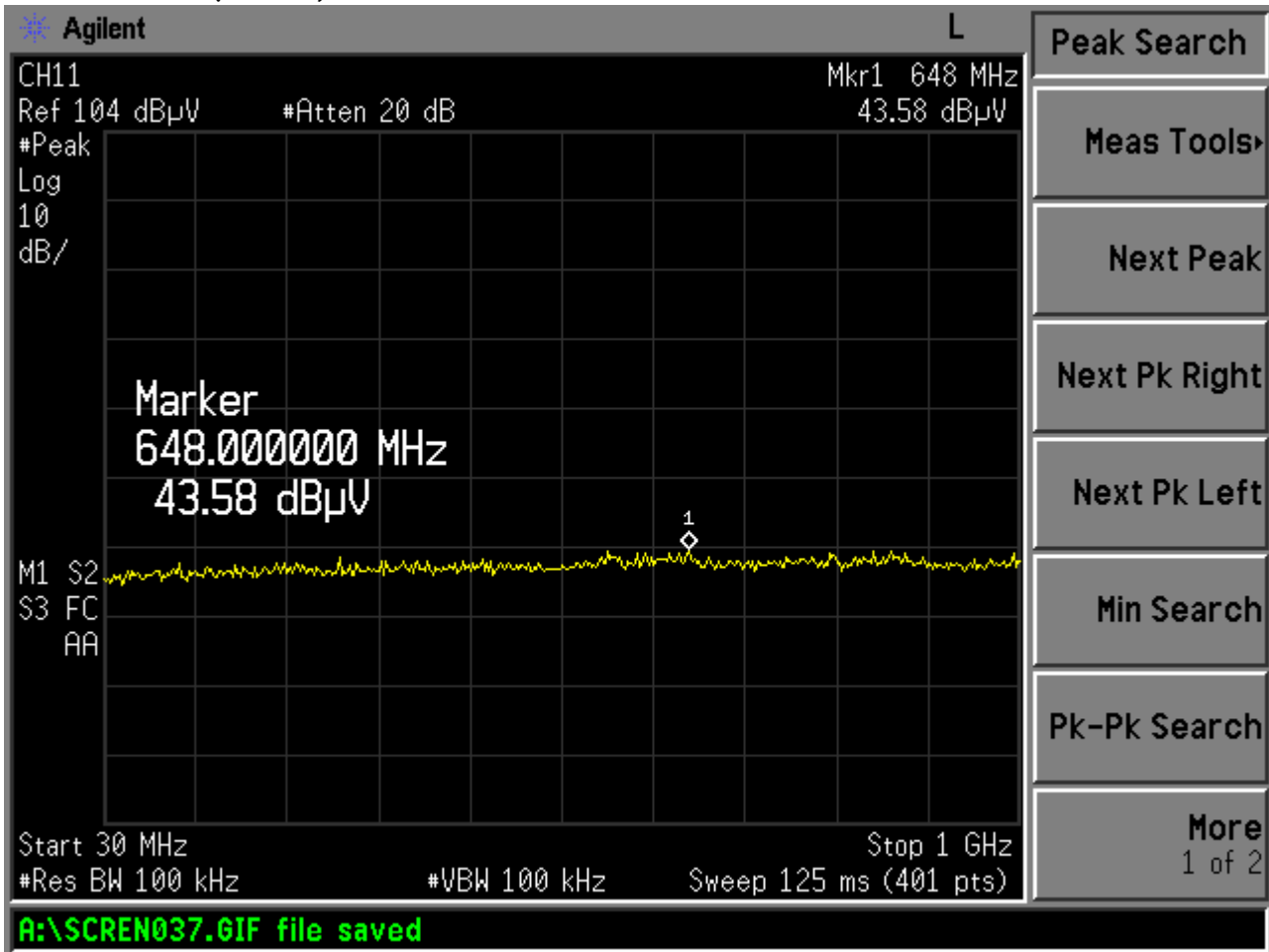



MAX LIGHT

MEASUREMENT REPORT

Channel 11 (2 of 5)

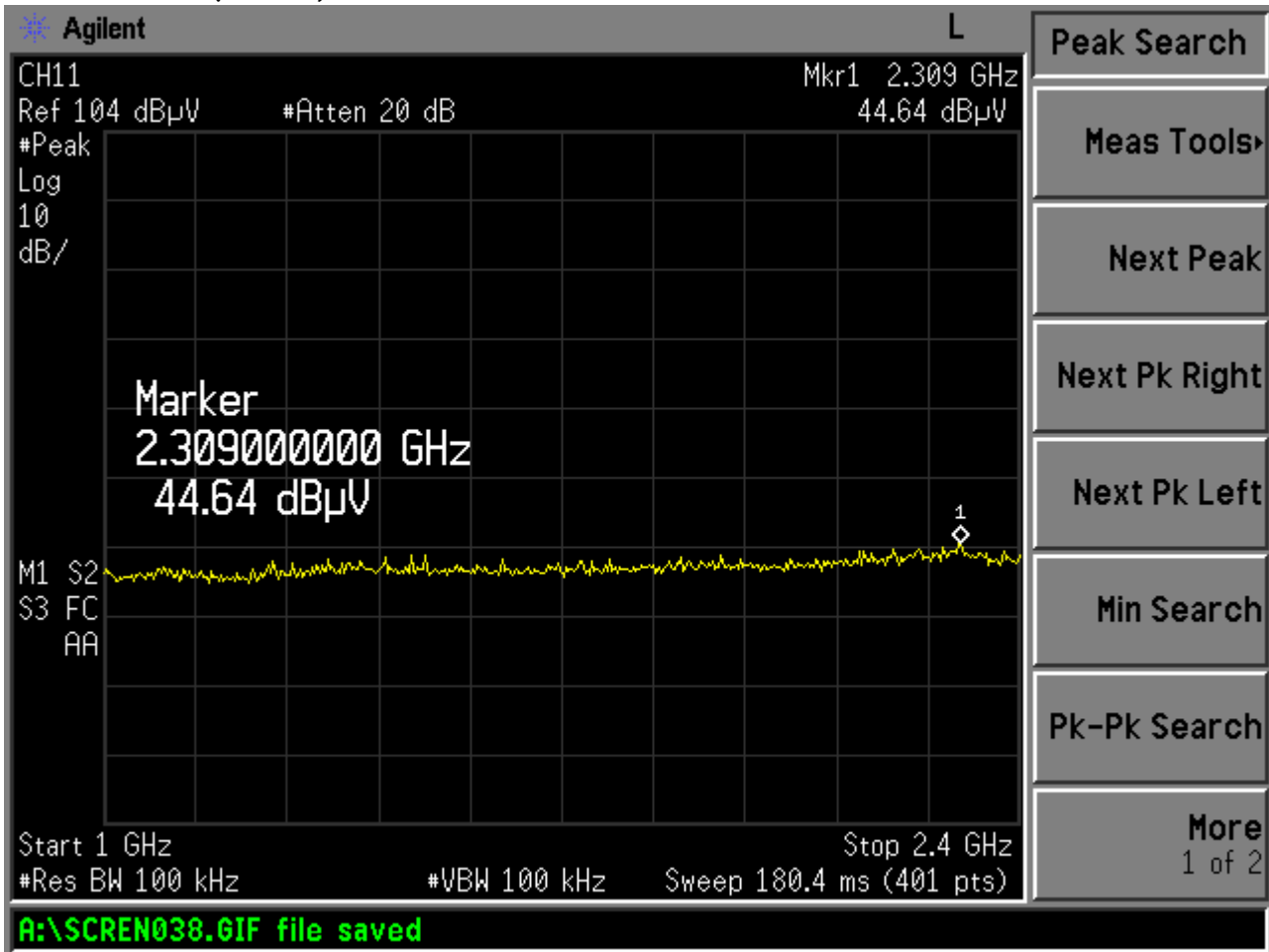

Channel 11 (3 of 5)

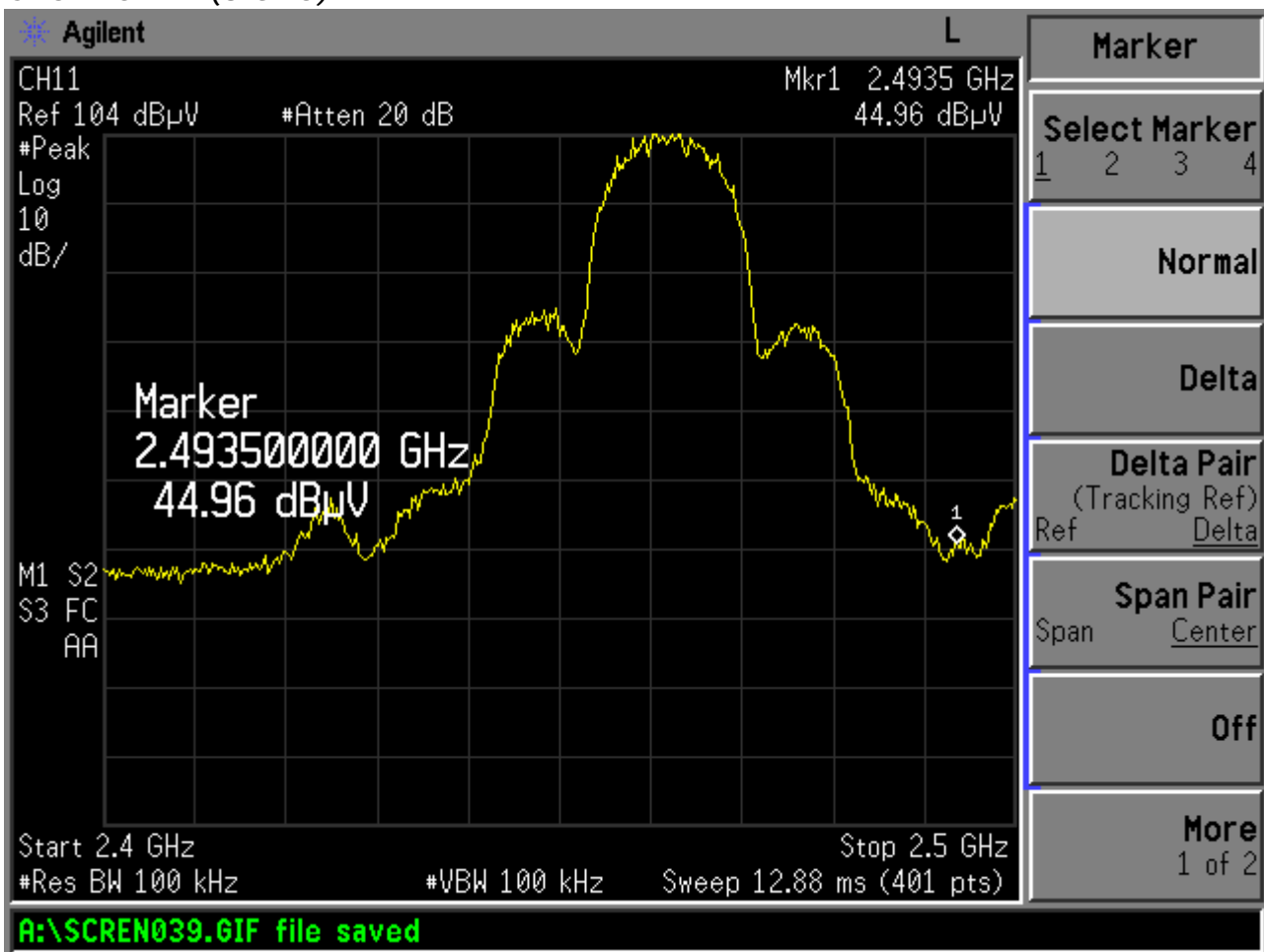

Channel 11 (4 of 5)

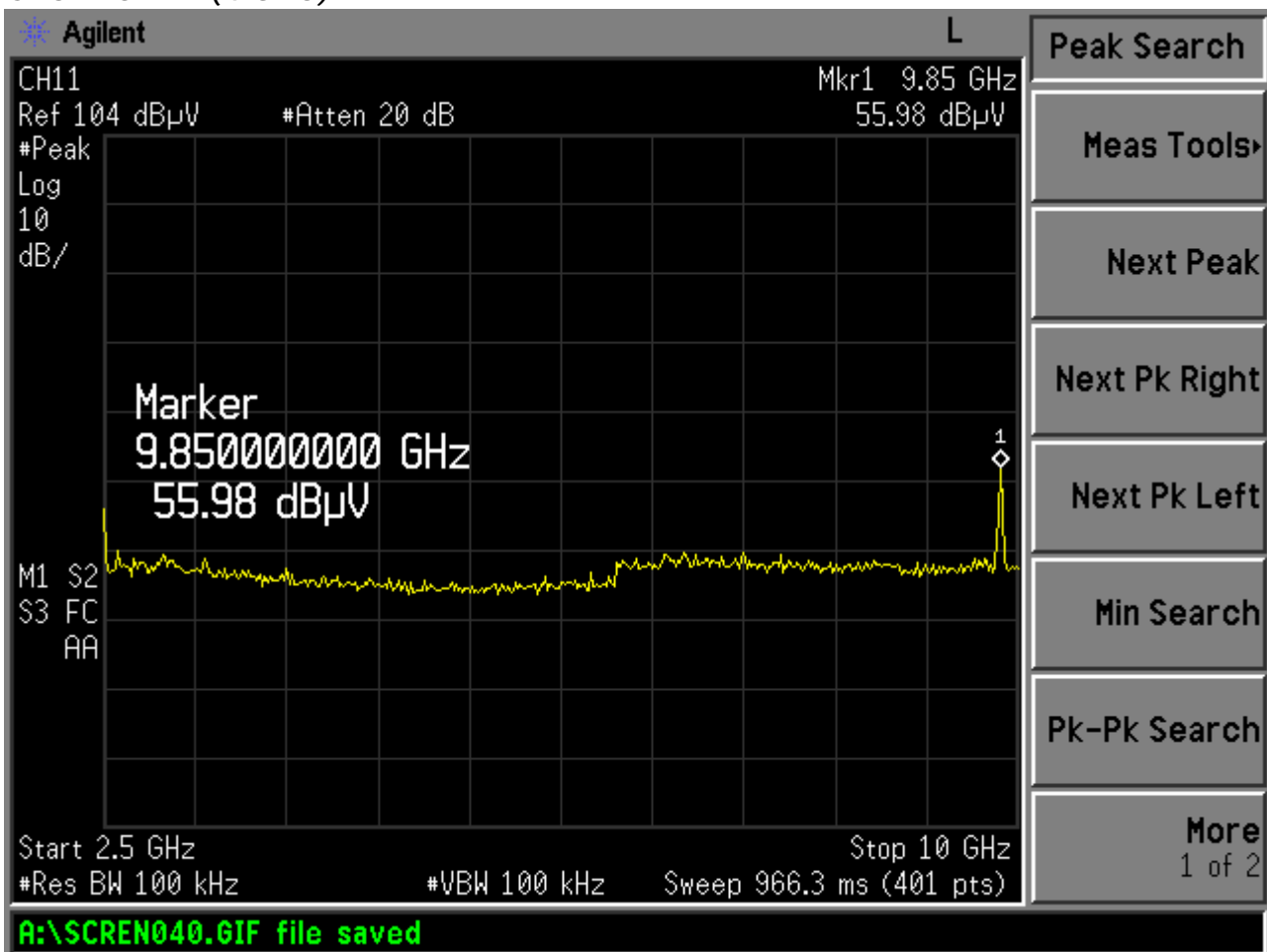



MAX LIGHT

MEASUREMENT REPORT

Channel 11 (5 of 5)

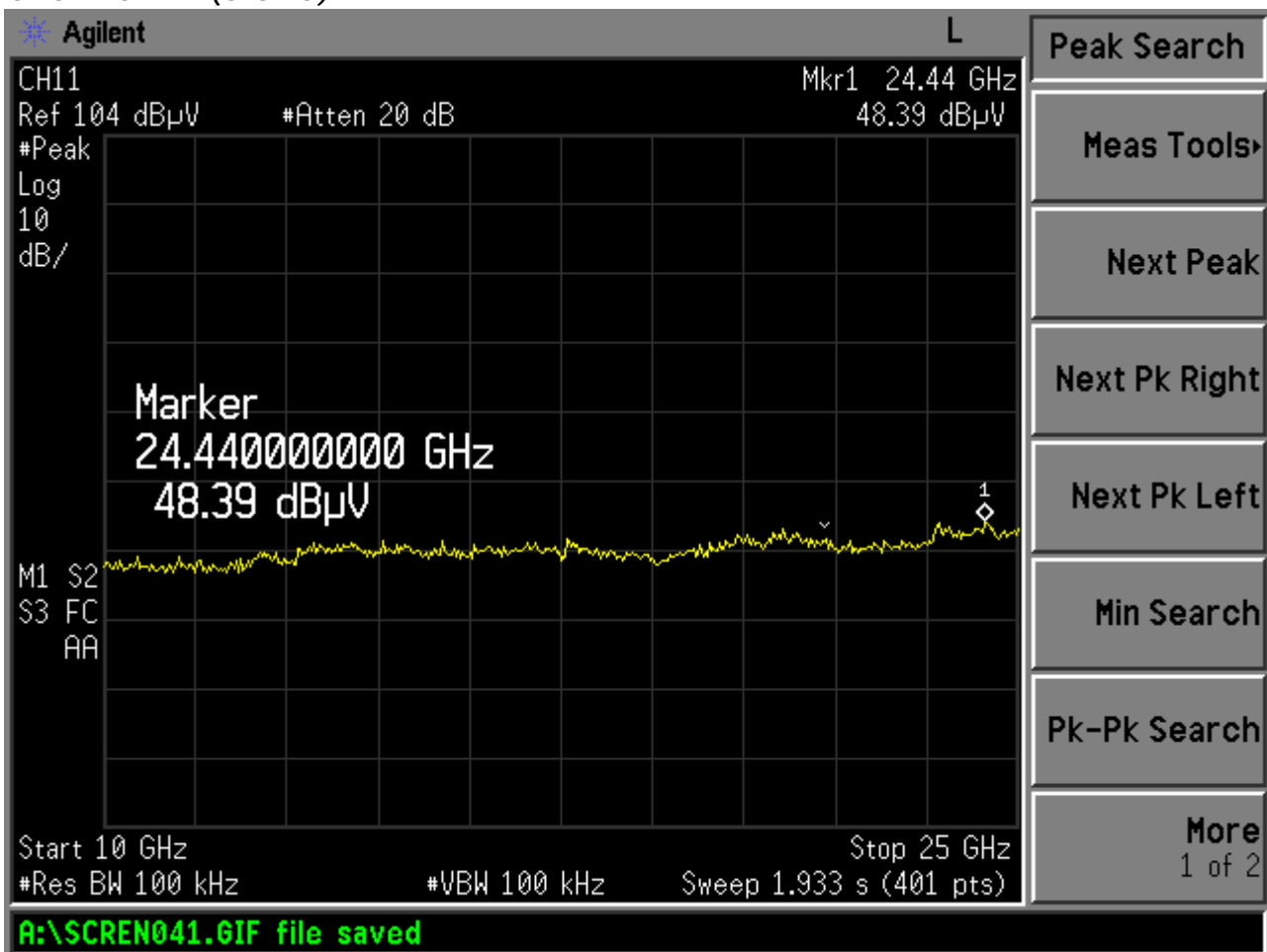

VIII. Band Edges Requirements

8.1 Test Condition & Setup :

The emissions on the harmonics frequencies, the limits, and the margin of compliance are presented. These tests were made when the transmitter was in full radiated power. The additional test was performed to show compliance with the requirement at the band-edge frequency 2483.5 MHz and up to 2500 MHz and at 2390.0 MHz.

The transmitter was configured with the worst case antenna and setup to transmit at the highest channel. Then the field strength was measured at 2483.5 MHz.

The transmitter was then configured with the worst case antenna and setup to transmit at the lowest channel. Then the field strength was measured at 2390.0 MHz. These tests were performed at 4 different bit rates.

8.2 Test Instruments Configuration:

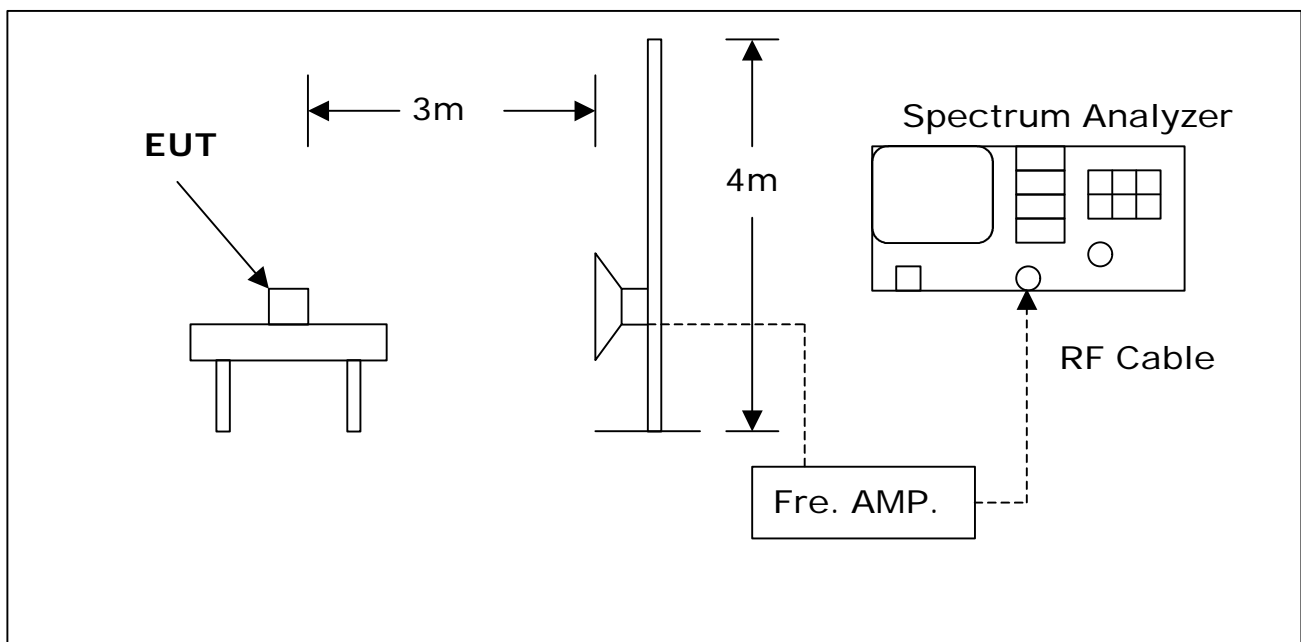



8.3 Test Equipment List:

- A. Agilent E4407B 9KHz-26.5GHz Spectrum Analyzer (S/N:A872JS02291)
- B. HP 8449B Pre Amplifier (S/N:1982901A91)
- C. SCHWARZBECK BBHA 9120D Biconilog Antenna (S/N:141S3)

8.4 Test Result:

Radiated Emissions (HORIZONTAL) CH1								
Frequency (MHz)	Amplitude (dBuV/m)	Ant. (m)	Table (Degree)	Duty (dB)	Dist (dB)	Actual Amp (dBuV/m)	Limit (dBuV/m)	Margin (dB)
23892.48	54.58	1	340	0	9.54	45.04	54.00	-8.96

Radiated Emissions (VERTICAL) CH1								
Frequency (MHz)	Amplitude (dBuV/m)	Ant. (m)	Table (Degree)	Duty (dB)	Dist (dB)	Actual Amp (dBuV/m)	Limit (dBuV/m)	Margin (dB)
23892.48	50.22	1.2	290	0	9.54	40.68	54.00	-13.32

Radiated Emissions (HORIZONTAL) CH11								
Frequency (MHz)	Amplitude (dBuV/m)	Ant. (m)	Table (Degree)	Duty (dB)	Dist (dB)	Actual Amp (dBuV/m)	Limit (dBuV/m)	Margin (dB)
24840.99	55.28	1	300	0	9.54	45.74	54.00	-8.26

Radiated Emissions (VERTICAL) CH11								
Frequency (MHz)	Amplitude (dBuV/m)	Ant. (m)	Table (Degree)	Duty (dB)	Dist (dB)	Actual Amp (dBuV/m)	Limit (dBuV/m)	Margin (dB)
24840.99	52.57	1	230	0	9.54	43.03	54.00	-10.97

- Notes :
- 1.Margin= Amplitude - Limits
 - 2.Height of table for EUT placed: 0.8 Meter.
 - 3.ANT= Antenna height.
 - 4.Duty= Duty cycle correction factor.
 - 5.Dis= Distance extrapolation factor.
 - 6.Amplitude= Reading Amplitude - Amplifier gain+Cable loss +Antenna factor
(Auto calculate in spectrum analyzer)
 - 8.Actual Amp= Amplitude - Duty - Dis.



IX. Processing Gain Requirements

9.1 Test Condition & Setup :

The processing gain shall be determined from the ratio in dB of the signal to noise ratio with the system spreading code turned OFF, to the signal to noise ratio with the system spreading code turned ON, as measured at the demodulated output of the receiver. The processing gain shall be at least 10 dB for a direct sequence spread spectrum system.

Note : Refer to circuit analysis and processing gain calculations provided by manufacturer. (Next page)



X. Antenna Requirements

10.1 Standard Applicable :

For intentional device, according to 15.203, an intentional radiator shall be designed to ensure that no antenna other than that furnished by the responsible party shall be used with the device.

And According to 15.247 (b), if transmitting antennas of directional gain greater than 6 dBi are used, the power shall be reduced by the amount in dB that the directional gain of the antenna exceeds 6dBi.

10.2 Antenna Connector Construction

The antenna used in this product is Printed antenna. No antenna connector is provided in this product. And the maximum Gain of this antenna is only 1.16dBi .

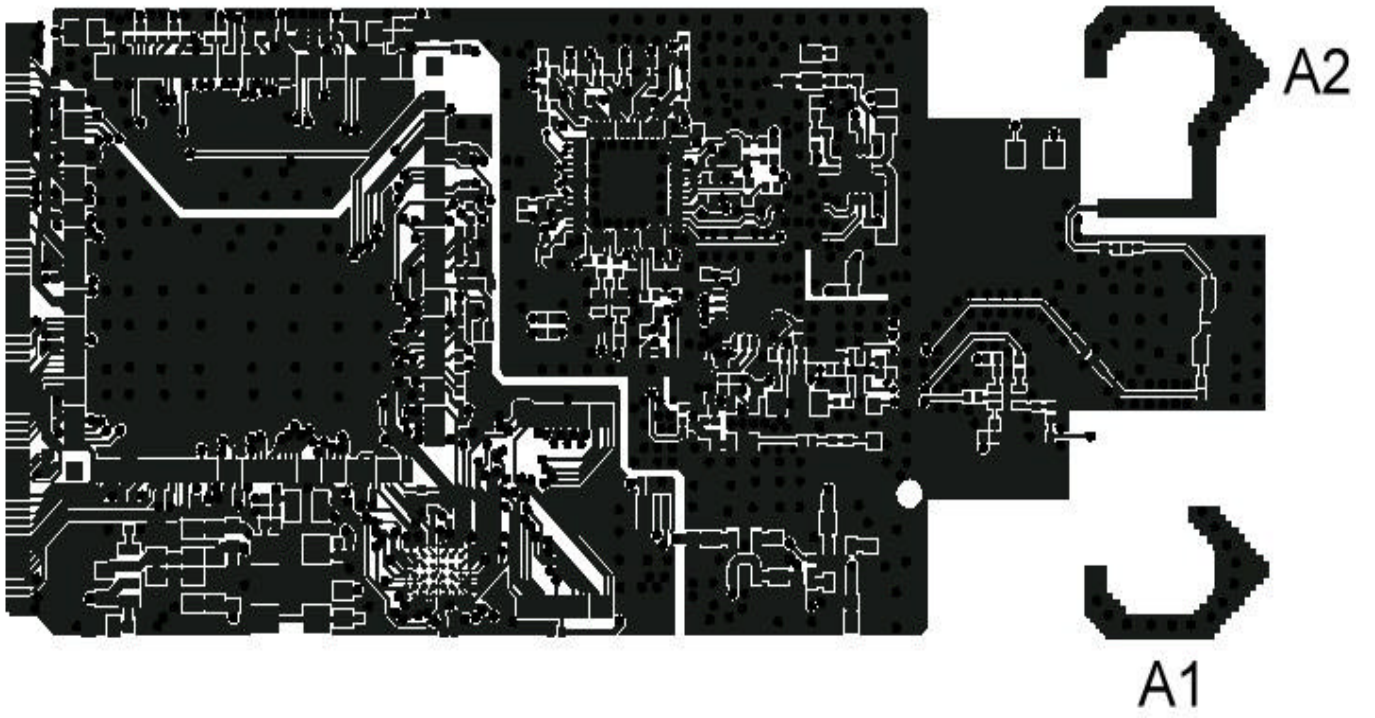

ANTENNA A1

EUT : VERTICAL
TEST DATE:2002/06/03

TEST FREQUENCY:2400MHz

TEST POLARIZATION:VERTICAL
(H-PLANE)
TEST ANTENNA: HORN ANTENNA

TEST STEP DEGREE: 2 DEGREE

TEST CHAMBER: RF CHAMBER

TEST PERSONNEL:BUNNY

MAX GAIN :-5.21dBi
MIN GAIN :-11.58dBi
AVE GAIN :-8.13dBi

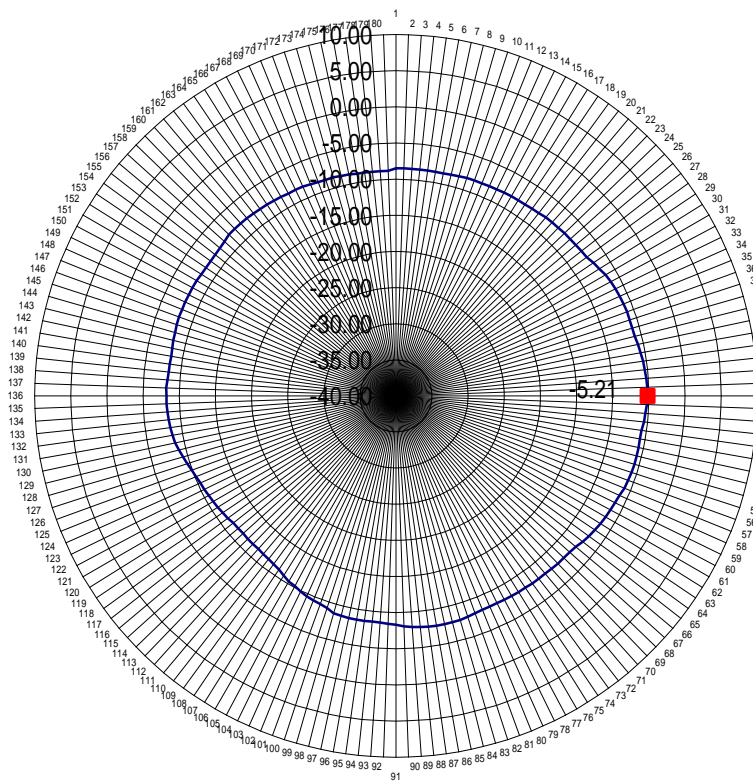

ANTENNA A1

EUT : HORIZONTAL
TEST DATE:2002/05/17

TEST FREQUENCY:2400MHz

TEST POLARIZATION:HORIZONTAL
(E-PLANE)

TEST ANTENNA: HORN ANTENNA

TEST STEP DEGREE: 2 DEGREE

TEST CHAMBER: RF CHAMBER

TEST PERSONNEL:BUNNY

MAX GAIN :1.04dBi
MIN GAIN :-17.73dBi
AVE GAIN:-4.62dBi

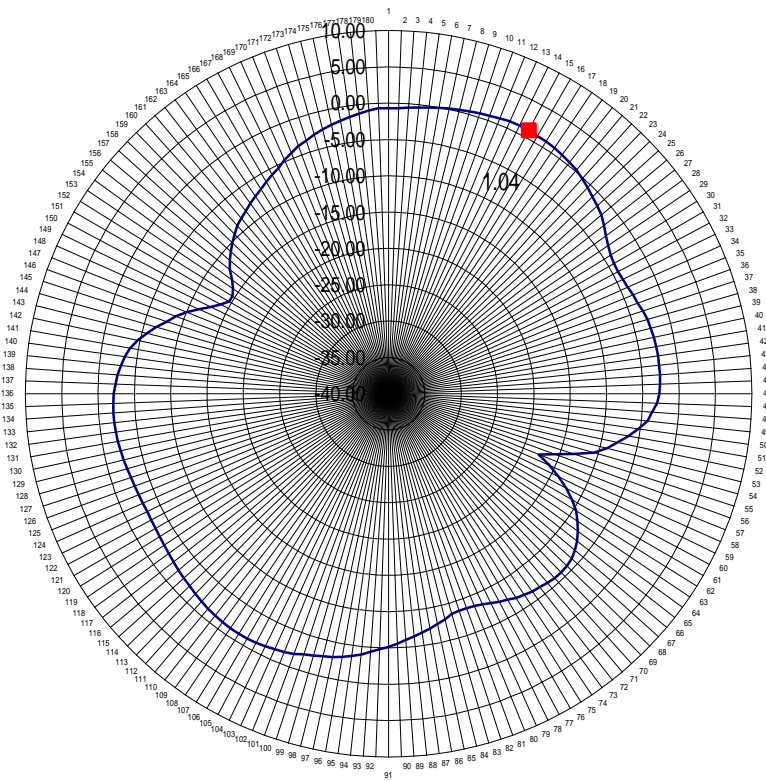

ANTENNA A1

EUT : VERTICAL
TEST DATE:2002/06/03

TEST FREQUENCY:2500MHz

TEST POLARIZATION:VERTICAL
(H-PLANE)
TEST ANTENNA: HORN ANTENNA

TEST STEP DEGREE: 2 DEGREE

TEST CHAMBER: RF CHAMBER

TEST PERSONNEL:BUNNY

MAX GAIN :-2.11dBi
MIN GAIN :-13.69dBi
AVE GAIN :-7.39dBi

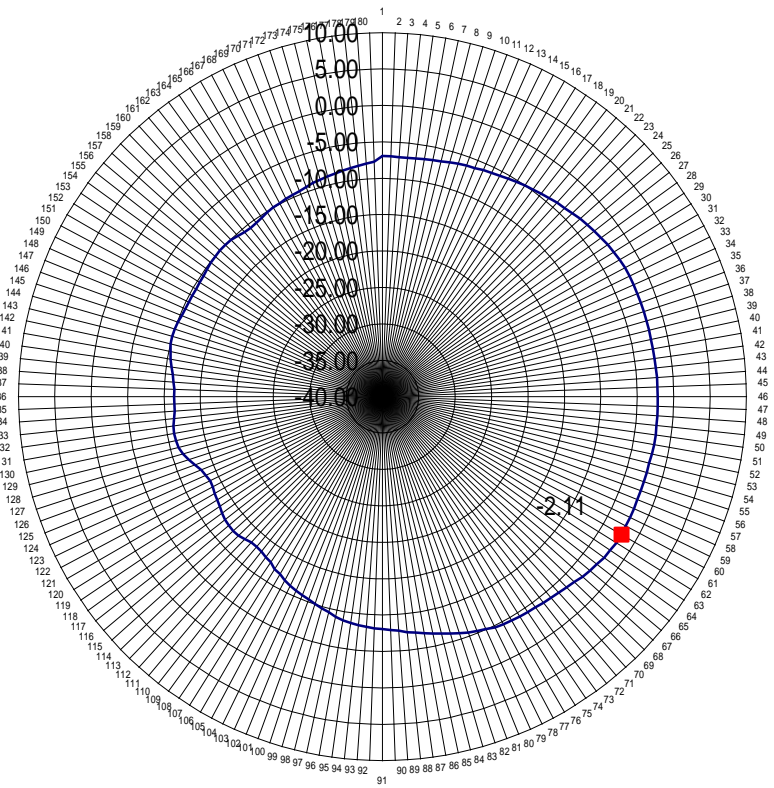

ANTENNA A1

EUT : HORIZONTAL
TEST DATE:2002/06/03

TEST FREQUENCY:2500MHZ

TEST POLARIZATION:HORIZONTAL
(E-PLANE)
TEST ANTENNA: HORN ANTENNA

TEST STEP DEGREE: 2 DEGREE

TEST CHAMBER: RF CHAMBER

TEST PERSONNEL:BUNNY

MAX GAIN :-0.01dBi
MIN GAIN : -17.71dBi
AVE GAIN: -4.99dBi

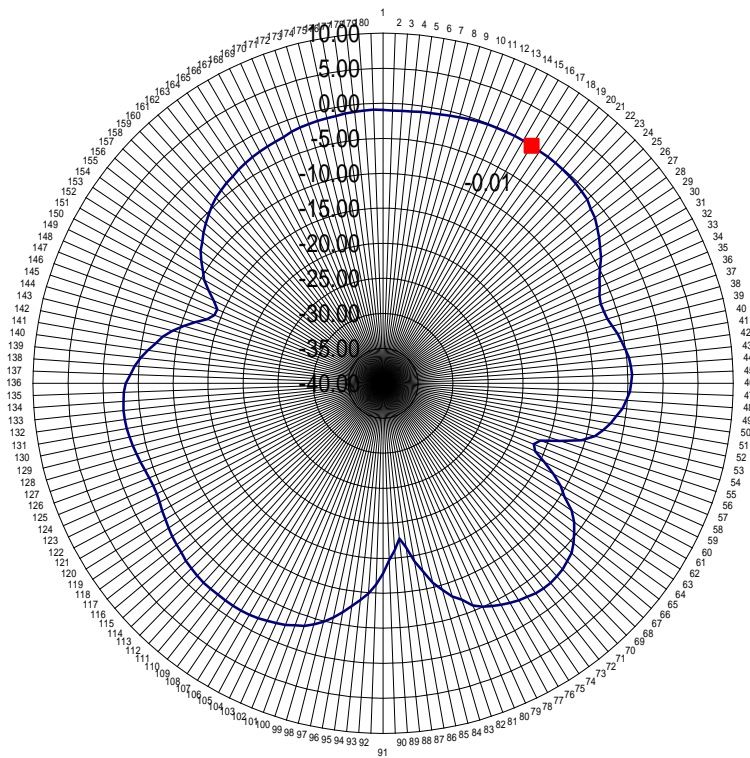

ANTENNA A2

EUT : VERTICAL
TEST DATE:2002/06/03

TEST FREQUENCY:2400MHz

TEST POLARIZATION:VERTICAL
(H-PLANE)

TEST ANTENNA: HORN ANTENNA

TEST STEP DEGREE: 2 DEGREE

TEST CHAMBER: RF CHAMBER

TEST PERSONNEL:BUNNY

MAX GAIN : -2.16dBi
MIN GAIN : -13.77dBi
AVE GAIN : -6.01dBi

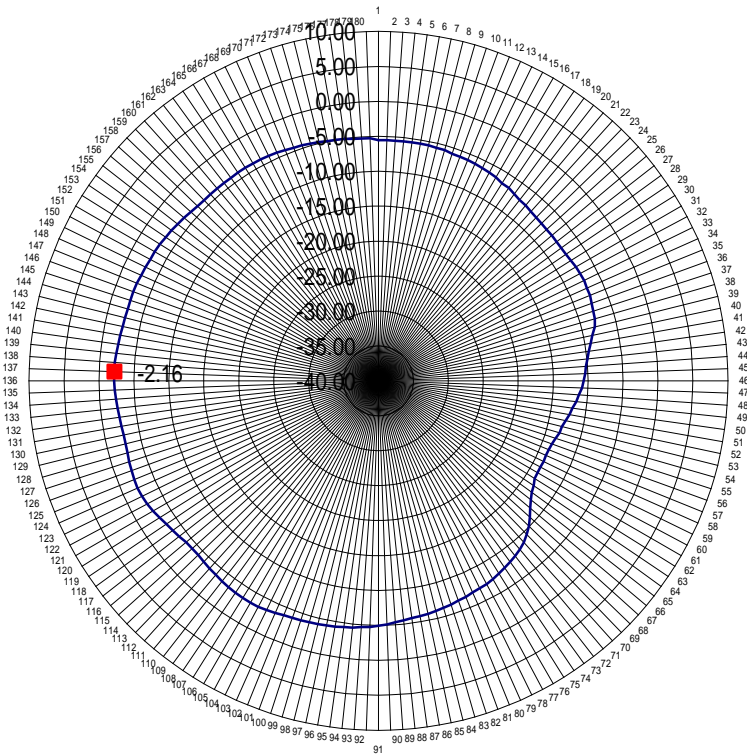

ANTENNA A2

EUT : HORIZONTAL
TEST DATE:2002/06/03

TEST FREQUENCY:2400MHz

TEST POLARIZATION:HORIZONTAL
(E-PLANE)

TEST ANTENNA: HORN ANTENNA

TEST STEP DEGREE: 2 DEGREE

TEST CHAMBER: RF CHAMBER

TEST PERSONNEL:BUNNY

MAX GAIN :-0.82dBi
MIN GAIN : -18.72dBi
AVE GAIN: -5.58dBi

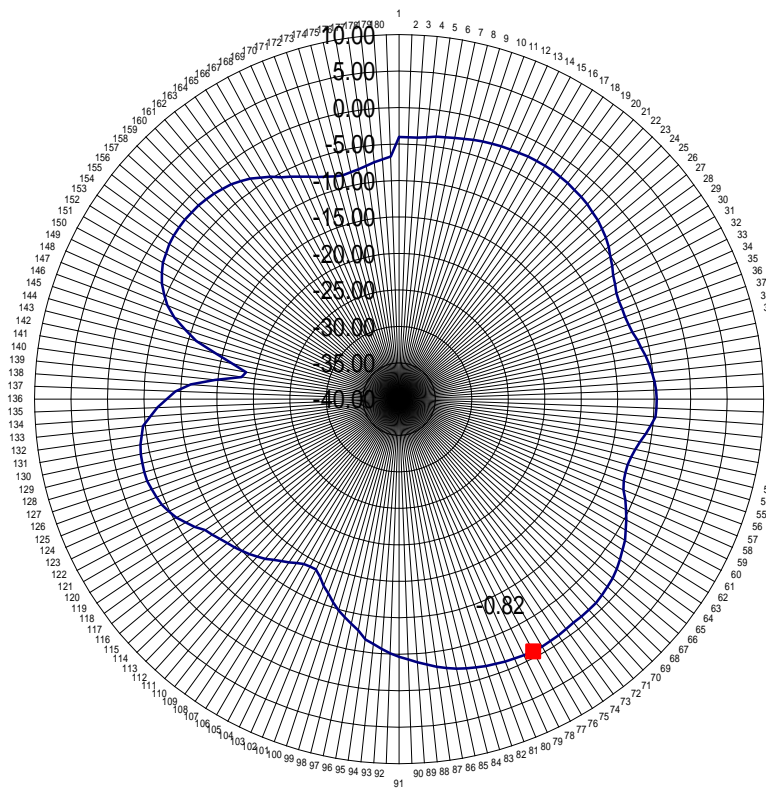

ANTENNA A2

EUT : VERTICAL
TEST DATE:2002/06/03
TEST FREQUENCY:2500MHZ
TEST POLARIZATION:HORIZONTAL
(E-PLANE)
TEST ANTENNA: HORN ANTENNA
TEST STEP DEGREE: 2 DEGREE
TEST CHAMBER: RF CHAMBER
TEST PERSONNEL:BUNNY

MAX GAIN :-3.89dBi
MIN GAIN : -26.36dBi
AVE GAIN: -10.33dBi

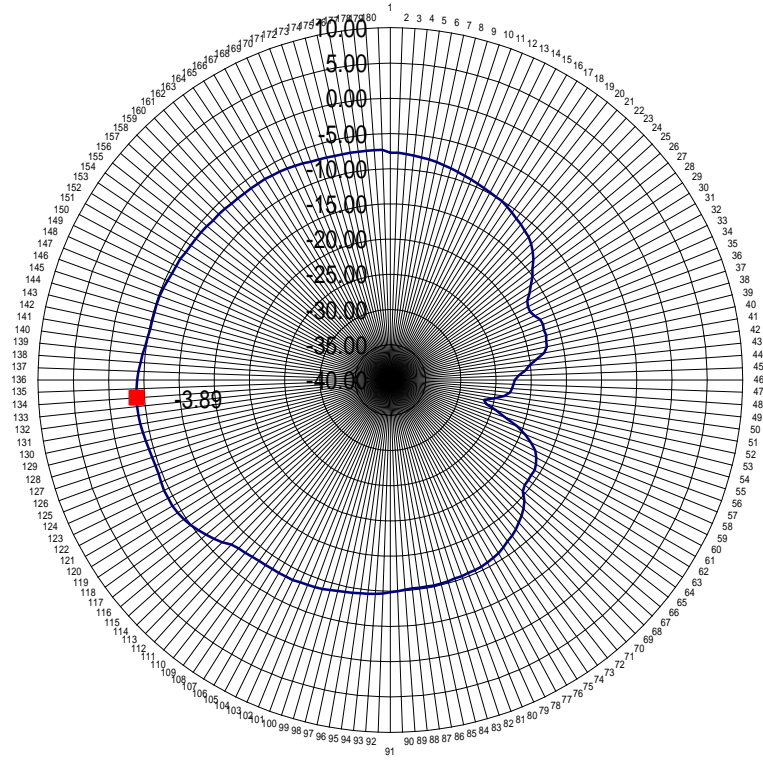

ANTENNA A2

EUT : HORIZONTAL
TEST DATE:2002/06/03

TEST FREQUENCY:2500MHz

TEST POLARIZATION:HORIZONTAL
(E-PLANE)

TEST ANTENNA: HORN ANTENNA

TEST STEP DEGREE: 2 DEGREE

TEST CHAMBER: RF CHAMBER

TEST PERSONNEL:BUNNY

MAX GAIN :1.16 dB
MIN GAIN :-16.89 dB
AVE GAIN: 5.43dB

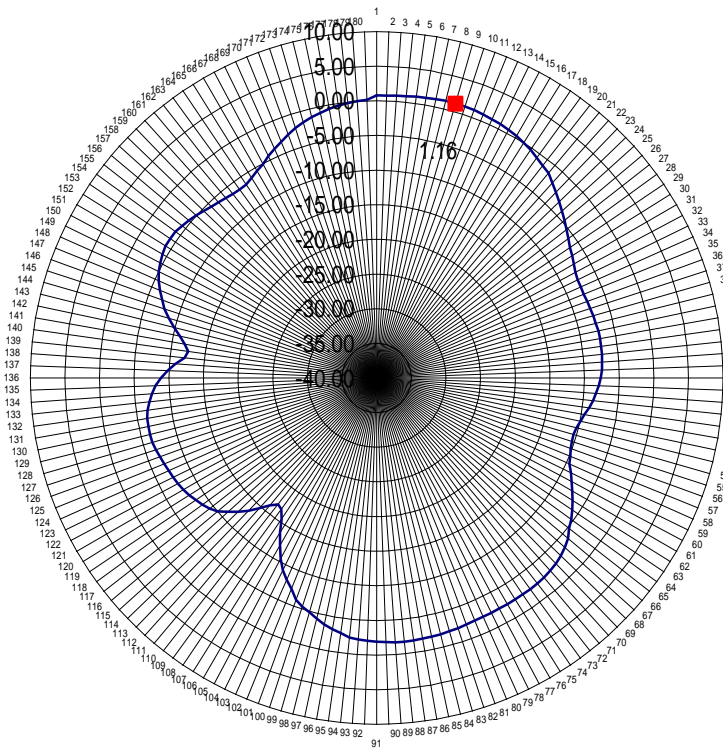

Appendix I- EUT Test SETUP

MEASUREMENT OF POWER LINE CONDUCTED RFI VOLTAGE

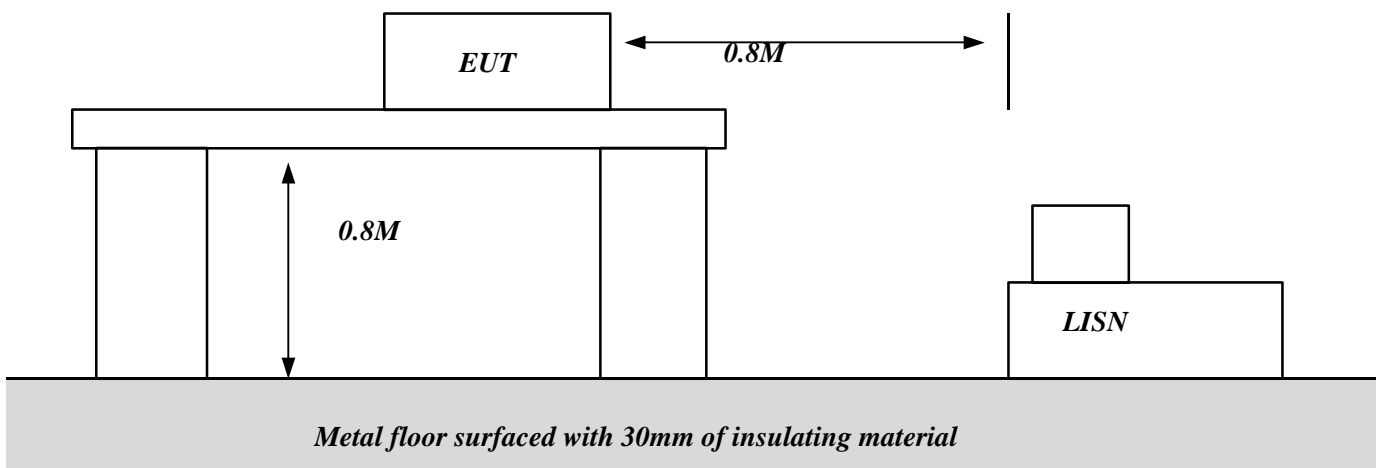

Appendix I- EUT Test SETUP

MEASUREMENT OF RADIATED EMISSION

