



**FCC OET BULLETIN 65 SUPPLEMENT C 01-01
IEEE STD 1528:2003**

SAR EVALUATION REPORT

For
WIFI 11A/N Module
(Tested inside of Host Device)

MODEL: MIC-A2
FCC ID: MCLMICA2

REPORT NUMBER: 12J14391-1A
ISSUE DATE: 05/25/2012

Prepared for
HON HAI PRECISION IND. CO., LTD.
5F-1, 5 HSIN-AN ROAD
HSINCHU SCIENCE-BASED INDUSTRIAL PARK
TAIWAN, R.O.C.

Prepared by
COMPLIANCE CERTIFICATION SERVICES (UL CCS)
47173 BENICIA STREET
FREMONT, CA 94538, U.S.A.
TEL: (510) 771-1000
FAX: (510) 661-0888



NVLAP LAB CODE 200065-0

Revision History

<u>Rev.</u>	<u>Issue Date</u>	<u>Revisions</u>	<u>Revised By</u>
--	5/24/2012	Initial Issue	--
A	5/25/2012	The following revisions were made to the report: <ol style="list-style-type: none">Section 8: Revised Antenna-to-Surface distance for the Rear test configuration of both antennasSection 15: Added photo of Elevation View of the DUT that illustrates the distance from the antennas to the Front and Rear surfaces	Ray Su

Table of Contents

1. Attestation of Test Results 5

2. Test Methodology..... 6

3. Facilities and Accreditation..... 6

4. Calibration and Uncertainty..... 7

 4.1. *Measuring Instrument Calibration 7*

 4.2. *Measurement Uncertainty..... 8*

5. Measurement System Description and Setup 9

6. SAR Measurement Procedure 10

 6.1. *Normal SAR Measurement Procedure..... 10*

 6.2. *Volume Scan Procedures 11*

7. Device Under Test..... 12

 7.1. *Band and Air Interfaces 12*

8. Summary of Test Configurations 13

 8.1. *Body Exposure Conditions for the Main Antenna..... 13*

 8.2. *Body Exposure Conditions for the Auxiliary Antenna 13*

9. RF Output Power Verification..... 14

10. Tissue Dielectric Property 17

 10.1. *Composition of Ingredients for the Tissue Material Used in the SAR Tests 18*

 10.2. *Tissue Dielectric Parameters Check Results..... 19*

11. System Performance Check 20

 11.1. *System Performance Check Measurement Conditions..... 20*

 11.2. *Reference SAR Values for System Performance Check..... 20*

 11.3. *System Performance Check Results 20*

 11.4. *System Check Plots 21*

12. SAR Test Results 29

 12.1. *SAR Test Plots..... 30*

13. Appendixes..... 44

 13.1. *Calibration Certificate for E-Field Probe EX3DV4 SN 3773 44*

 13.2. *Calibration Certificate for D5GHzV2 SN 1075 44*

14. External/Host Device Photos..... 45

15. Antenna Locations & Separation Distances.....	46
16. Set-up Photos.....	47

1. Attestation of Test Results

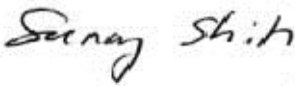
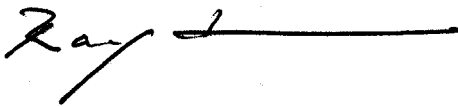
Applicant:	Hon Hai Precision Ind. Co., Ltd.		
EUT description:	WIFI 11A/N Module (Tested inside of Host)		
Model number:	MIC-A2		
Device category:	Portable		
Device type:	An identical prototype		
Exposure category:	General Population/Uncontrolled Exposure		
Date tested:	5/11/2012 – 5/12/2012		
FCC/IC Rule Parts	Freq. Range [MHz]	Highest 1-g SAR	Limit (W/kg)
15.407	5180 - 5240	0.552 W/kg (Edge 1, w/ 5 mm separation distance)	1.6
15.247	5745 - 5825	0.358 W/kg (Edge 1, w/ 5 mm separation distance)	
Applicable Standards			Test Results
FCC OET Bulletin 65 Supplement C 01-01, IEEE STD 1528:2003			Pass
<p>Compliance Certification Services, Inc. (UL CCS) tested the above equipment in accordance with the requirements set forth in the above standards. All indications of Pass/Fail in this report are opinions expressed by UL CCS based on interpretations and/or observations of test results. Measurement Uncertainties were not taken into account and are published for informational purposes only. The test results show that the equipment tested is capable of demonstrating compliance with the requirements as documented in this report.</p> <p>Note: The results documented in this report apply only to the tested sample, under the conditions and modes of operation as described herein. This document may not be altered or revised in any way unless done so by UL CCS and all revisions are duly noted in the revisions section. Any alteration of this document not carried out by UL CCS will constitute fraud and shall nullify the document. This report must not be used by the client to claim product certification, approval, or endorsement by NVLAP, NIST, any agency of the Federal Government, or any agency of any government (NIST Handbook 150, Annex A). This report is written to support regulatory compliance of the applicable standards stated above.</p>			
Approved & Released For UL CCS By:		Tested By:	
			
Sunny Shih Engineering Leader Compliance Certification Services (UL CCS)		Ray Su SAR Engineer Compliance Certification Services (UL CCS)	

2. Test Methodology

The tests documented in this report were performed in accordance with FCC OET Bulletin 65 Supplement C 01-01, IEEE STD 1528:2003 and the following KDB Test Procedures.

- 248227 D01 SAR meas for 802.11abg v01r02
- 865664 SAR 3 to 6 GHz Rev
- 941225 D07 UMPC Mini Tablet Devices v01
- KDB Inquiry: 454638

3. Facilities and Accreditation

The test sites and measurement facilities used to collect data are located at 47173 Benicia Street, Fremont, California, USA.

UL CCS is accredited by NVLAP, Laboratory Code 200065-0. The full scope of accreditation can be viewed at <http://www.ccsemc.com>.

4. Calibration and Uncertainty

4.1. Measuring Instrument Calibration

The measuring equipment utilized to perform the tests documented in this report has been calibrated in accordance with the manufacturer's recommendations, and is traceable to recognized national standards.

Name of Equipment	Manufacturer	Type/Model	Serial No.	Cal. Due date		
				MM	DD	Year
Dielectronic Probe kit	HP	85070C	N/A	N/A		
S-Parameter Network Analyzer	Agilent	8753ES-6	MY40001647	11	22	2012
Signal Generator	Agilent	8753ES-6	MY40001647	11	22	2012
Synthesized Signal Generator	HP	83732B	US34490599	7	14	2012
E-Field Probe	SPEAG	EX3DV4	3773	3	14	2013
Thermometer	ERTCO	639-1S	1718	7	19	2012
Data Acquisition Electronics	SPEAG	DAE3	500	7	14	2012
System Validation Dipole	SPEAG	D5GHzV2	1075	2	14	2013
Power Meter	Giga-tronics	8651A	8651404	5	13	2012
Power Sensor	Giga-tronics	80701A	1834588	5	13	2012
Amplifier	MITEQ	4D00400600-50-30P	1620606	N/A		
Directional coupler	Werlatone	C8060-102	2141	N/A		

4.2. Measurement Uncertainty

Measurement uncertainty for 3 to 6 GHz averaged over 1 gram					
Component	Error, %	Distribution	Divisor	Sensitivity	U (X), %
Measurement System					
Probe Calibration (k=1)	6.55	Normal	1	1	6.55
Axial Isotropy	1.15	Rectangular	1.732	0.7071	0.47
Hemispherical Isotropy	2.30	Rectangular	1.732	0.7071	0.94
Boundary Effect	0.90	Rectangular	1.732	1	0.52
Probe Linearity	3.45	Rectangular	1.732	1	1.99
System Detection Limits	1.00	Rectangular	1.732	1	0.58
Readout Electronics	1.00	Normal	1	1	1.00
Response Time	0.80	Rectangular	1.732	1	0.46
Integration Time	2.60	Rectangular	1.732	1	1.50
RF Ambient Conditions - Noise	3.00	Rectangular	1.732	1	1.73
RF Ambient Conditions - Reflections	3.00	Rectangular	1.732	1	1.73
Probe Positioner Mechanical Tolerance	0.40	Rectangular	1.732	1	0.23
Probe Positioning with respect to Phantom	2.90	Rectangular	1.732	1	1.67
Extrapolation, Interpolation and Integration	3.90	Rectangular	1.732	1	2.25
Test Sample Related					
Test Sample Positioning	1.10	Normal	1	1	1.10
Device Holder Uncertainty	3.60	Normal	1	1	3.60
Output Power Variation - SAR Drift	5.00	Rectangular	1.732	1	2.89
Phantom and Tissue Parameters					
Phantom Uncertainty (shape and thickness)	4.00	Rectangular	1.732	1	2.31
Liquid Conductivity - deviation from target	5.00	Rectangular	1.732	0.64	1.85
Liquid Conductivity - measurement	4.35	Normal	1	0.64	2.78
Liquid Permittivity - deviation from target	10.00	Rectangular	1.732	0.6	3.46
Liquid Permittivity - measurement uncertainty	4.32	Normal	1	0.6	2.59
Combined Standard Uncertainty U _c (y), %:					11.12
Expanded Uncertainty U, Coverage Factor = 1.96, > 95 % Confidence =				21.80 %	
Expanded Uncertainty U, Coverage Factor = 1.96, > 95 % Confidence =				1.71 dB	

5. Measurement System Description and Setup

The DASY5 system used for performing compliance tests consists of the following items:

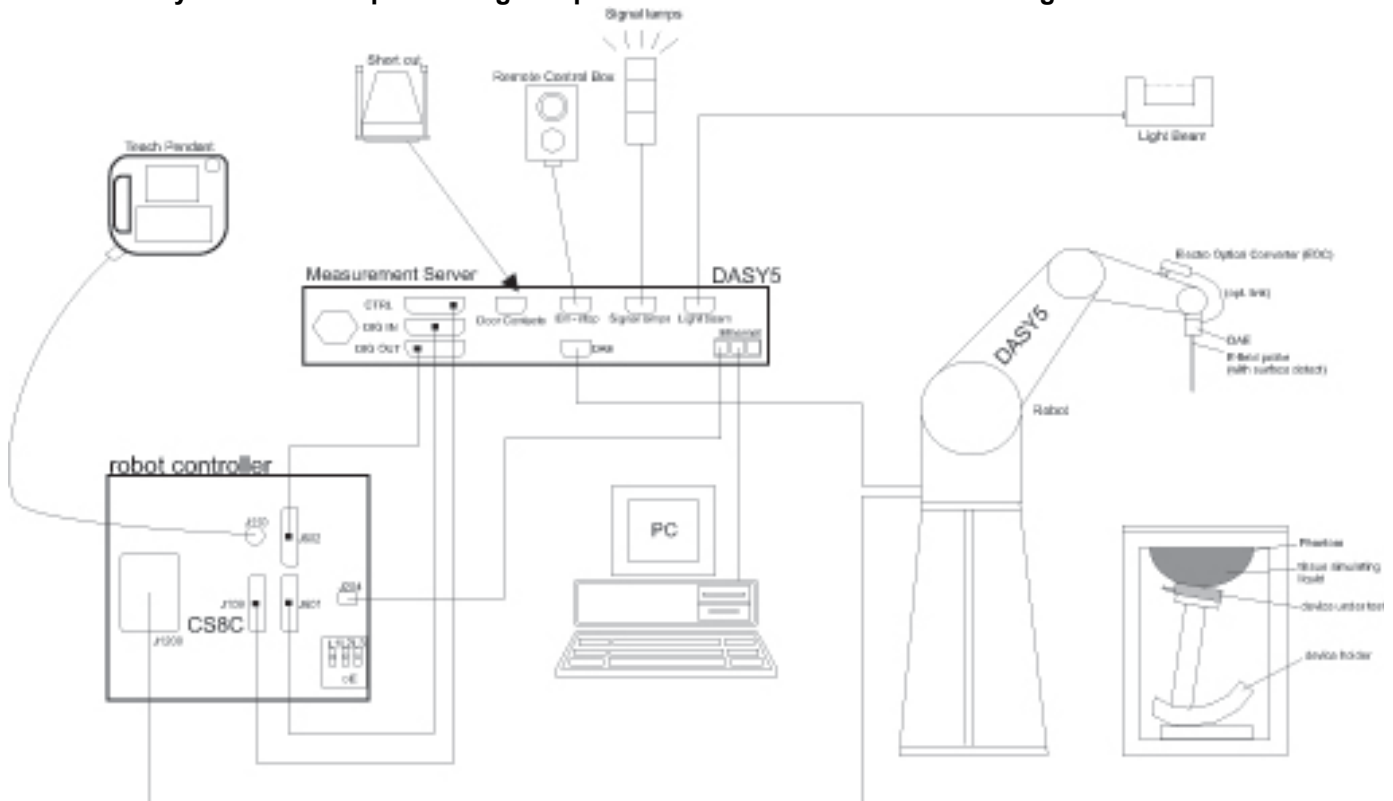

- A standard high precision 6-axis robot with controller, teach pendant and software. An arm extension for accommodating the data acquisition electronics (DAE).
- An isotropic Field probe optimized and calibrated for the targeted measurement.
- A data acquisition electronics (DAE) which performs the signal amplification, signal multiplexing, AD-conversion, offset measurements, mechanical surface detection, collision detection, etc. The unit is battery powered with standard or rechargeable batteries. The signal is optically transmitted to the EOC.
- The Electro-optical converter (EOC) performs the conversion from optical to electrical signals for the digital communication to the DAE. To use optical surface detection, a special version of the EOC is required. The EOC signal is transmitted to the measurement server.
- The function of the measurement server is to perform the time critical tasks such as signal filtering, control of the robot operation and fast movement interrupts.
- The Light Beam used is for probe alignment. This improves the (absolute) accuracy of the probe positioning.
- A computer running WinXP or Win7 and the DASY5 software.
- Remote control and teach pendant as well as additional circuitry for robot safety such as warning lamps, etc.
- The phantom, the device holder and other accessories according to the targeted measurement.

6. SAR Measurement Procedure

6.1. Normal SAR Measurement Procedure

Step 1: Power Reference Measurement

The Power Reference Measurement and Power Drift Measurements are for monitoring the power drift of the device under test in the batch process. The Minimum distance of probe sensors to surface determines the closest measurement point to phantom surface. The minimum distance of probe sensors to surface is 2.1 mm. This distance cannot be smaller than the Distance of sensor calibration points to probe tip as defined in the probe properties.

Step 2: Area Scan

The Area Scan is used as a fast scan in two dimensions to find the area of high field values, before doing a fine measurement around the hot spot. The sophisticated interpolation routines implemented in DASY software can find the maximum locations even in relatively coarse grids. When an Area Scan has measured all reachable points, it computes the field maximal found in the scanned area, within a range of the global maximum. The range (in dB) is specified in the standards for compliance testing. For example, a 2 dB range is required in IEEE Standard 1528 and EN 62209 standards, whereby 3 dB is a requirement when compliance is assessed in accordance with the ARIB standard (Japan). If only one Zoom Scan follows the Area Scan, then only the absolute maximum will be taken as reference. For cases where multiple maximums are detected, the number of Zoom Scans has to be increased accordingly.

Step 3: Zoom Scan

Zoom Scans are used to assess the peak spatial SAR values within a cubic averaging volume containing 1 g and 10 g of simulated tissue. The Zoom Scan measures $\geq 7 \times 7 \times 9$ (above 3 GHz) or $5 \times 5 \times 7$ (below 3 GHz) points within a cube whose base faces are centered on the maxima found in a preceding area scan job within the same procedure. When the measurement is done, the Zoom Scan evaluates the averaged SAR for 1 g and 10 g and displays these values next to the job's label.

Step 4: Power drift measurement

The Power Drift Measurement measures the field at the same location as the most recent power reference measurement within the same procedure, and with the same settings. The Power Drift Measurement gives the field difference in dB from the reading conducted within the last Power Reference Measurement. This allows a user to monitor the power drift of the device under test within a batch process. The measurement procedure is the same as Step 1.

Step 5: Z-Scan

The Z Scan measures points along a vertical straight line. The line runs along the Z-axis of a one-dimensional grid. In order to get a reasonable extrapolation, the extrapolated distance should not be larger than the step size in Z-direction.

6.2. Volume Scan Procedures

Step 1: Power Reference Measurement

The Power Reference Measurement and Power Drift Measurements are for monitoring the power drift of the device under test in the batch process. The minimum distance of probe sensors to surface determines the closest measurement point to phantom surface. The minimum distance of probe sensors to surface is 2.1 mm. This distance cannot be smaller than the distance of sensor calibration points to probe tip as defined in the probe properties.

Step 2: Area Scan

The Area Scan is used as a fast scan in two dimensions to find the area of high field values, before doing a fine measurement around the hot spot. The sophisticated interpolation routines implemented in DASY software can find the maximum locations even in relatively coarse grids. When an Area Scan has measured all reachable points, it computes the field maximal found in the scanned area, within a range of the global maximum. The range (in dB) is specified in the standards for compliance testing. For example, a 2 dB range is required in IEEE Standard 1528 and IEC 62209 standards, whereby 3 dB is a requirement when compliance is assessed in accordance with the ARIB standard (Japan). If only one Zoom Scan follows the Area Scan, then only the absolute maximum will be taken as reference. For cases where multiple maximums are detected, the number of Zoom Scans has to be increased accordingly.

Step 3: Zoom Scan

Zoom Scans are used to assess the peak spatial SAR values within a cubic averaging volume containing 1 g and 10 g of simulated tissue. The Zoom Scan measures $\geq 7 \times 7 \times 9$ (above 4.5 GHz) or $5 \times 5 \times 7$ (below 3 GHz) points within a cube whose base faces are centered on the maxima found in a preceding area scan job within the same procedure. When the measurement is done, the Zoom Scan evaluates the averaged SAR for 1 g and 10 g and displays these values next to the job's label.

Step 4: Volume Scan

Volume Scans are used to assess peak SAR and averaged SAR measurements in largely extended 3-dimensional volumes within any phantom. This measurement does not need any previous area scan. The grid can be anchored to a user specific point or to the current probe location.

Step 5: Power drift measurement

The Power Drift Measurement measures the field at the same location as the most recent power reference measurement within the same procedure, and with the same settings. The Power Drift Measurement gives the field difference in dB from the reading conducted within the last Power Reference Measurement. This allows a user to monitor the power drift of the device under test within a batch process. The measurement procedure is the same as Step 1.

7. Device Under Test

WIFI 11A/N Module (Tested inside of host device) Model: MIC-A2			
Mode of operation:	Hand-held or lap-held		
Antenna tested:	<u>Manufacturer</u>	<u>Part number</u>	<u>Antenna Gain (dBi)</u>
	Foxconn	Main: ANT2V1 Aux: ANT2V2	0.23 0.23

7.1. Band and Air Interfaces

Tx Frequency Bands	802.11an:	5150 - 5250 MHz, a / HT20 5725 - 5850 MHz, a / HT20
--------------------	-----------	--

8. Summary of Test Configurations

Refer to Section 15 “Antenna Location and Separation Distances” for the specific details of the antenna-to-antenna and antenna-to-edge(s) distances.

8.1. Body Exposure Conditions for the Main Antenna

Configuration	Antenna-to-edge/surface	SAR Required	Note
Rear (bottom)	32.6 mm	Yes	
Front	3.4	Yes	
Edge 1	4.2 mm	Yes	
Edge 2	172.7 mm	No	SAR is not required because the distance from the tested antenna to this edge is > 2.5 cm and is not the most conservative exposure condition
Edge 3	128.6 mm	No	Ditto
Edge 4	57.7 mm	No	Ditto

8.2. Body Exposure Conditions for the Auxiliary Antenna

Configuration	Antenna-to-edge/surface	SAR Required	Note
Rear (bottom)	32.6 mm	Yes	
Front	3.4	Yes	
Edge 1	4.2 mm	Yes	
Edge 2	57.7 mm	No	SAR is not required because the distance from the tested antenna to this edge is > 2.5 cm and is not the most conservative exposure condition
Edge 3	128.6 mm	No	Ditto
Edge 4	172.7 mm	No	Ditto

9. RF Output Power Verification

Required Test Channels per KDB 248227 D01

Mode	Band	GHz	Channel	"Default Test Channels"	
				802.11b	802.11g
802.11b/g	2.4 GHz	2.412	1 [#]	√	∇
		2.437	6	√	∇
		2.462	11 [#]	√	∇

Mode		Band	GHz	Channel	"Default Test Channels"	
802.11a	UNII (15.407)	5.2 GHz	5.180	36	√	
			5.200	40		*
			2.220	44		*
			5.240	48	√	
		5.3 GHz	5.260	52	√	
			5.280	56		*
			5.300	60		*
			5.320	64	√	
		5.5 GHz	5.500	100		
			5.520	104	√	
			5.540	108		*
			5.560	112		*
	5.580		116	√		
	5.600		120		*	
	5.620		124	√		
	5.640		128		*	
	5.8 GHz	5.660	132		*	
		5.680	136	√		
		5.700	140		*	
		DTS (15.247)	5.745	149	√	
5.765	153			*		
5.785	157		√			
5.805	161			*		
5.825	165		√			

* = possible 802.11a channels with maximum average output > the "default test channels"
 √ = "default test channels"
 ∇ = possible 802.11g channels with maximum average output ¼ dB ≥ the "default test channels"
 # = when output power is reduced for channel 1 and /or 11 to meet restricted band requirements the highest output channels closest to each of these channels should be tested.

5.2 GHz

Band (GHz)	Mode	Ch. #	Freq. (MHz)	Target Avg Pwr (dBm) from original EMC report		Measured Avg Pwr (dBm)	
				Main Ant.	Aux Ant.	Main Ant.	Aux Ant.
5.2	802.11a	36	5180	10.5		10.6	
		40	5200	10.8		10.8	
		44	5220			10.5	
		48	5240	10.7		10.8	
		36	5180		10.5		10.6
		40	5200		10.8		10.8
		44	5220				10.6
		48	5240		10.7		10.8
	802.11n HT20	36	5180	10.7			
		40	5200	10.8			
		48	5240	10.8			
		36	5180		10.7		
		40	5200		10.8		
		48	5240		10.8		

Note(s):

1. The modes with highest output power channel were chosen for the conducted output power.
2. Original average output power is from EMC report 11U13871-1. Refer to original report (FCC ID: MCLMICA2) for Average Power information as documented in 7/5/2011 original filing.
3. Per KDB 248227, SAR is not required for 802.11n HT20 modes because its maximum average output power is less than 1/4 dB higher than that measured on the corresponding 802.11a channels.

5.8 GHz

Band (GHz)	Mode	Ch. #	Freq. (MHz)	Target Avg Pwr (dBm) from original EMC report		Measured Avg Pwr (dBm)	
				Main Ant.	Aux Ant.	Main Ant.	Aux Ant.
5.8	802.11a	149	5745	10.9		10.9	
		153	5765			10.7	
		157	5785	10.5		10.7	
		161	5805			10.6	
		165	5825	10.6		10.7	
		149	5745		10.9		10.9
		153	5765				10.7
		157	5785		10.5		10.7
		161	5805				10.7
	165	5825		10.6		10.7	
	802.11n HT20	149	5745	10.8			
		157	5785	10.5			
		165	5825	10.6			
		149	5745		10.8		
157		5785		10.5			
		165	5825		10.6		

Notes:

1. The modes with highest output power channel were chosen for the conducted output power.
2. Original average output power is from EMC report 11U13871-6. Refer to original report (FCC ID: MCLMICA2) for Average Power information as documented in 7/14/2011 original filing.
3. Per KDB 248227 - SAR is not required for 802.11n HT20/HT40 modes due to the maximum average output power is less than 1/4 dB higher than that measured on the corresponding 802.11a channels.

10. Tissue Dielectric Property

IEEE Std 1528-2003 Table 2

Target Frequency (MHz)	Head	
	ϵ_r	σ (S/m)
300	45.3	0.87
450	43.5	0.87
835	41.5	0.90
900	41.5	0.97
1450	40.5	1.20
1800 – 2000	40.0	1.40
2450	39.2	1.80
2600	39.0	1.96
3000	38.5	2.40

FCC OET Bulletin 65 Supplement C 01-01

Target Frequency (MHz)	Head		Body	
	ϵ_r	σ (S/m)	ϵ_r	σ (S/m)
150	52.3	0.76	61.9	0.8
300	45.3	0.87	58.2	0.92
450	43.5	0.87	56.7	0.94
835	41.5	0.9	55.2	0.97
900	41.5	0.97	55	1.05
915	41.5	0.98	55	1.06
1450	40.5	1.2	54	1.3
1610	40.3	1.29	53.8	1.4
1800 – 2000	40	1.4	53.3	1.52
2450	39.2	1.8	52.7	1.95
3000	38.5	2.4	52	2.73
5000	36.2	4.45	49.3	5.07
5100	36.1	4.55	49.1	5.18
5200	36.0	4.66	49.0	5.30
5300	35.9	4.76	48.9	5.42
5400	35.8	4.86	48.7	5.53
5500	35.6	4.96	48.6	5.65
5600	35.5	5.07	48.5	5.77
5700	35.4	5.17	48.3	5.88
5800	35.3	5.27	48.2	6.00

10.2. Tissue Dielectric Parameters Check Results

Tissue dielectric parameters measured at the low, middle and high frequency of each operating frequency range of the test device.

Date	Freq. (MHz)	Liquid Parameters		Measured	Target	Delta (%)	Limit ±(%)		
5/11/2012	Body 5180	e'	51.1678	Relative Permittivity (ϵ_r):	51.17	49.05	4.32	10	
		e"	18.3515	Conductivity (σ):	5.29	5.27	0.27	5	
	Body 5200	e'	51.1356	Relative Permittivity (ϵ_r):	51.14	49.02	4.32	10	
		e"	18.3594	Conductivity (σ):	5.31	5.29	0.26	5	
	Body 5500	e'	50.6174	Relative Permittivity (ϵ_r):	50.62	48.61	4.12	10	
		e"	18.6886	Conductivity (σ):	5.72	5.64	1.26	5	
	Body 5800	e'	50.1585	Relative Permittivity (ϵ_r):	50.16	48.20	4.06	10	
		21	19.0070	Conductivity (σ):	6.13	6.00	2.16	5	
	Body 5825	e'	50.1187	Relative Permittivity (ϵ_r):	50.12	48.20	3.98	10	
		e"	19.0270	Conductivity (σ):	6.16	6.00	2.71	5	
	5/12/2012	Body 5180	e'	51.1590	Relative Permittivity (ϵ_r):	51.16	49.05	4.31	10
			e"	18.6350	Conductivity (σ):	5.37	5.27	1.82	5
Body 5200		e'	51.1318	Relative Permittivity (ϵ_r):	51.13	49.02	4.31	10	
		e"	18.6735	Conductivity (σ):	5.40	5.29	1.97	5	
Body 5500		e'	50.5679	Relative Permittivity (ϵ_r):	50.57	48.61	4.02	10	
		e"	18.9494	Conductivity (σ):	5.80	5.64	2.67	5	
Body 5800		e'	50.0370	Relative Permittivity (ϵ_r):	50.04	48.20	3.81	10	
		21	19.2527	Conductivity (σ):	6.21	6.00	3.48	5	
Body 5825		e'	50.0005	Relative Permittivity (ϵ_r):	50.00	48.20	3.74	10	
		e"	19.3315	Conductivity (σ):	6.26	6.00	4.35	5	

11. System Performance Check

The system performance check is performed prior to any usage of the system in order to verify SAR system measurement accuracy. The system performance check verifies that the system operates within its specifications of $\pm 10\%$.

11.1. System Performance Check Measurement Conditions

- The measurements were performed in the flat section of the TWIN SAM or ELI phantom, shell thickness: 2.0 ± 0.2 mm (bottom plate) filled with Body or Head simulating liquid of the following parameters.
- The DASY system with an E-Field Probe was used for the measurements.
- The dipole was mounted on the small tripod so that the dipole feed point was positioned below the center marking of the flat phantom section and the dipole was oriented parallel to the body axis (the long side of the phantom). The standard measuring distance was 10 mm (above 1 GHz) and 15 mm (below 1 GHz) from dipole center to the simulating liquid surface.
- The coarse grid with a grid spacing of 15 mm was aligned with the dipole.
For 5 GHz band - The coarse grid with a grid spacing of 10 mm was aligned with the dipole.
- Special 7x7x7 fine cube was chosen for cube.
- Distance between probe sensors and phantom surface was set to 3 mm.
For 5 GHz band - Distance between probe sensors and phantom surface was set to 2.5 mm
- The dipole input power (forward power) was 100 mW.
- The results are normalized to 1 W input power.

11.2. Reference SAR Values for System Performance Check

The reference SAR values can be obtained from the calibration certificate of system validation dipoles

System Dipole	Serial No.	Cal. Date	Freq. (MHz)	SAR Measured (mW/g)		
				1g/10g	Head	Body
D5GHzV2	1075	2/14/12	5200	1g	79.7	72.8
				10g	22.9	20.5
			5500	1g	86.1	77.7
				10g	24.5	21.7
			5800	1g	79.4	72.4
				10g	22.7	20.2

11.3. System Performance Check Results

Date Tested	System validation dipole		Measured (Normalized to 1 W)		Target	Delta (%)	Tolerance (%)
			1g SAR:	10g SAR:			
05/11/12	Body	5200	1g SAR:	71.3	72.8	-2.06	± 10
			10g SAR:	20.3	20.5	-0.98	
	Body	5800	1g SAR:	68.2	72.4	-5.80	± 10
			10g SAR:	19.0	20.2	-5.94	
05/11/12	Body	5200	1g SAR:	74.6	72.8	2.47	± 10
			10g SAR:	21.3	20.5	3.90	
	Body	5800	1g SAR:	72.1	72.4	-0.41	± 10
			10g SAR:	20.4	20.2	0.99	

11.4. System Check Plots

Test Laboratory: UL CCS SAR Lab C

Date: 5/11/2012

20120511_SystemPerformanceCheck-D5GHzV2 SN 1075

Frequency: 5200 MHz; Duty Cycle: 1:1; Room Ambient Temperature: 25.0°C; Liquid Temperature: 24.0°C
Medium parameters used: $f = 5200$ MHz; $\sigma = 5.311$ mho/m; $\epsilon_r = 51.136$; $\rho = 1000$ kg/m³

DASY5 Configuration:

- Electronics: DAE3 Sn500; Calibrated: 7/14/2011
- Probe: EX3DV4 - SN3773; ConvF(4.15, 4.15, 4.15); Calibrated: 3/14/2012
- Sensor-Surface: 2.5mm (Mechanical Surface Detection)
- Phantom: ELI v5.0 (A); Type: QDOVA001BB; Serial: 1120

Body/5.2 GHz, Pin=100mW 2/Area Scan (7x7x1): Measurement grid: dx=10mm, dy=10mm

Maximum value of SAR (measured) = 12.609 mW/g

Body/5.2 GHz, Pin=100mW 2/Zoom Scan (8x8x10)/Cube 0: Measurement grid: dx=4mm, dy=4mm, dz=2.5mm

Reference Value = 51.761 V/m; Power Drift = 0.04 dB

Peak SAR (extrapolated) = 25.8890

SAR(1 g) = 7.13 mW/g; SAR(10 g) = 2.03 mW/g

Maximum value of SAR (measured) = 12.802 mW/g

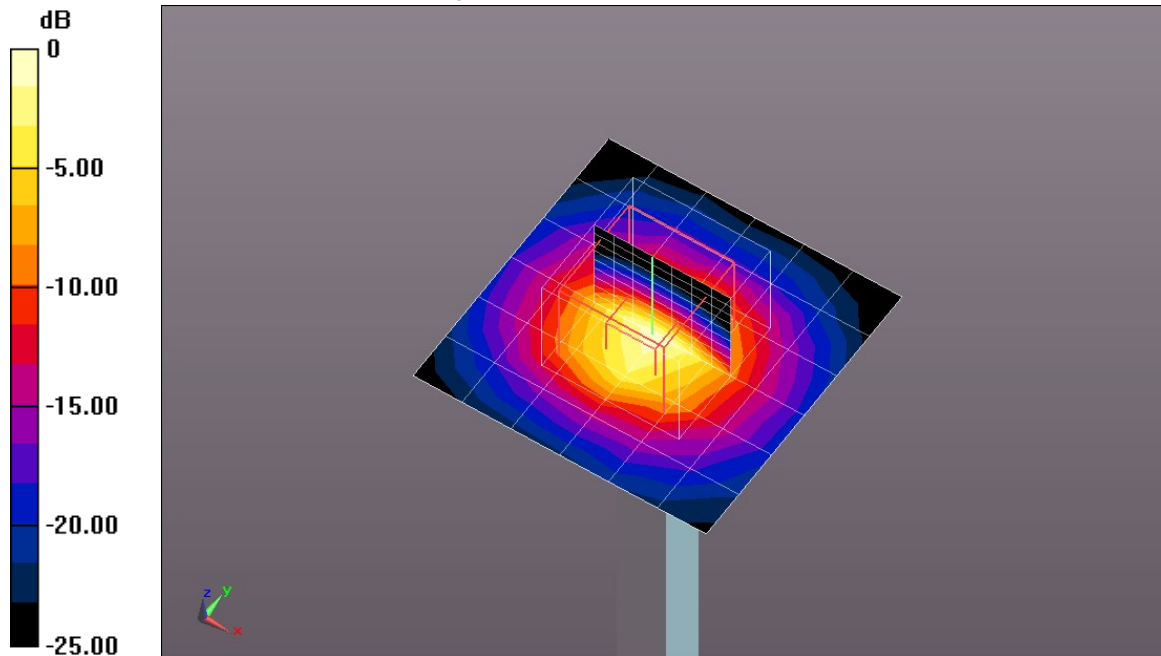

0 dB = 12.800mW/g = 22.14 dB mW/g

Test Laboratory: UL CCS SAR Lab C

Date: 5/11/2012

20120511_SystemPerformanceCheck-D5GHzV2 SN 1075

Frequency: 5200 MHz; Duty Cycle: 1:1

Body/5.2 GHz, Pin=100mW 2/Z Scan (1x1x21): Measurement grid: dx=20mm, dy=20mm, dz=5mm
Maximum value of SAR (measured) = 4.646 mW/g

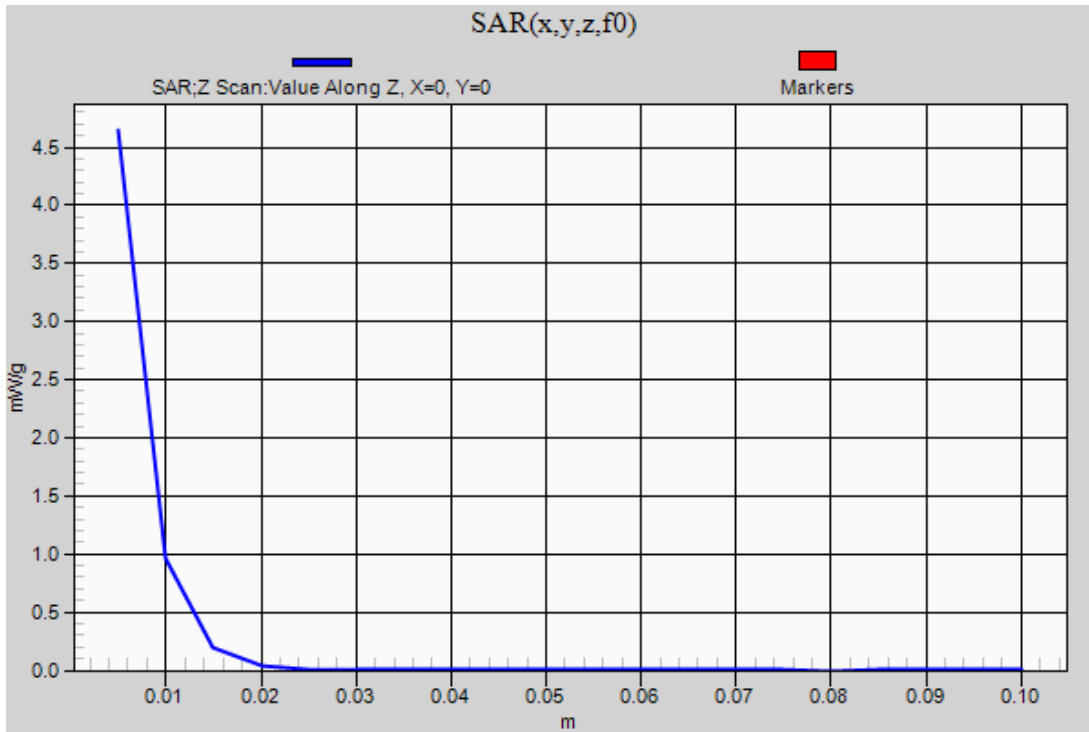

Test Laboratory: UL CCS SAR Lab C

Date: 5/11/2012

20120511_SystemPerformanceCheck-D5GHzV2 SN 1075

Frequency: 5800 MHz; Duty Cycle: 1:1; Room Ambient Temperature: 25.0°C; Liquid Temperature: 24.0°C
Medium parameters used: $f = 5800$ MHz; $\sigma = 6.133$ mho/m; $\epsilon_r = 50.158$; $\rho = 1000$ kg/m³

DASY5 Configuration:

- Electronics: DAE3 Sn500; Calibrated: 7/14/2011
- Probe: EX3DV4 - SN3773; ConvF(3.57, 3.57, 3.57); Calibrated: 3/14/2012
- Sensor-Surface: 2.5mm (Mechanical Surface Detection)
- Phantom: ELI v5.0 (A); Type: QDOVA001BB; Serial: 1120

Body/5.8 GHz, Pin=100mW/Area Scan (7x7x1): Measurement grid: dx=10mm, dy=10mm
Maximum value of SAR (measured) = 12.497 mW/g

Body/5.8 GHz, Pin=100mW/Zoom Scan (8x8x10)/Cube 0: Measurement grid: dx=4mm, dy=4mm, dz=2.5mm
Reference Value = 49.103 V/m; Power Drift = -0.15 dB
Peak SAR (extrapolated) = 26.1050
SAR(1 g) = 6.82 mW/g; SAR(10 g) = 1.9 mW/g
Maximum value of SAR (measured) = 12.424 mW/g

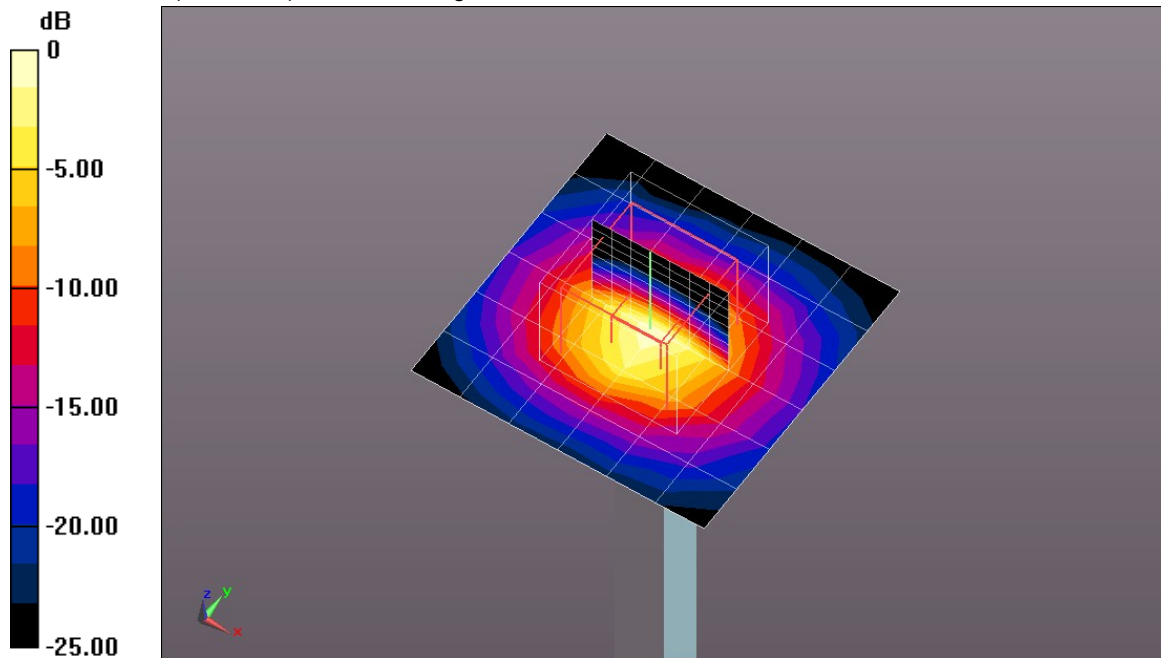

0 dB = 12.420mW/g = 21.88 dB mW/g

Test Laboratory: UL CCS SAR Lab C

Date: 5/11/2012

20120511_SystemPerformanceCheck-D5GHzV2 SN 1075

Frequency: 5800 MHz; Duty Cycle: 1:1

Body/5.8 GHz, Pin=100mW/Z Scan (1x1x21): Measurement grid: dx=20mm, dy=20mm, dz=5mm
Maximum value of SAR (measured) = 3.965 mW/g

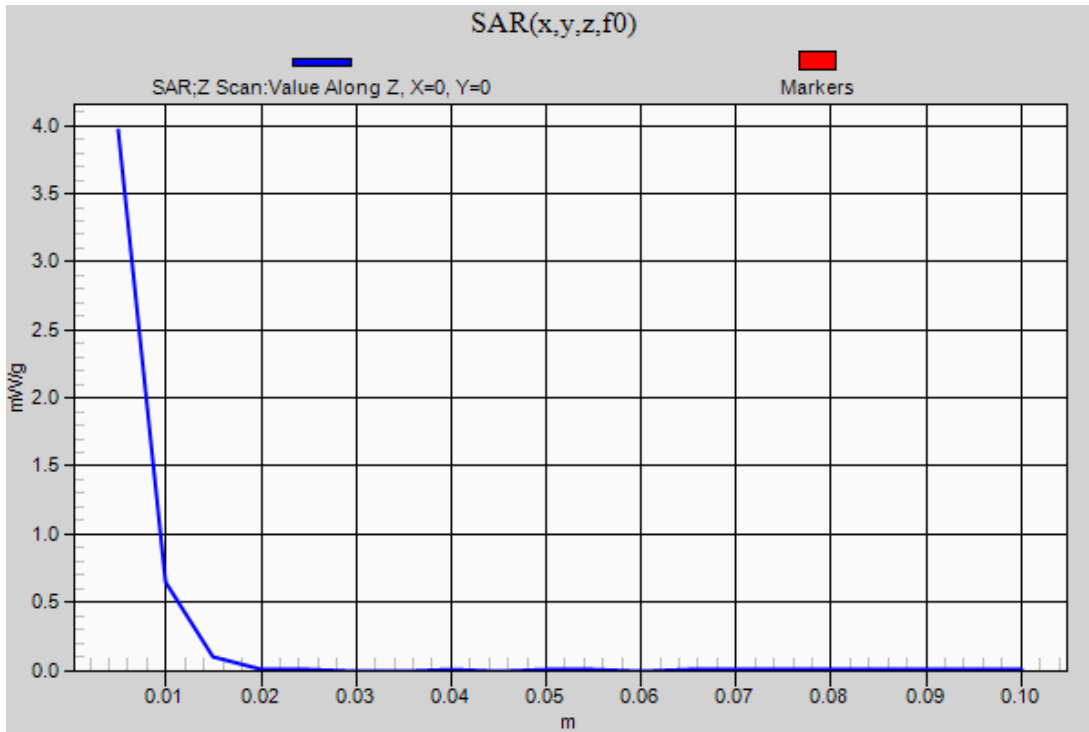

Test Laboratory: UL CCS SAR Lab C

Date: 5/12/2012

20120512_SystemPerformanceCheck-D5GHzV2 SN 1075

Frequency: 5200 MHz; Duty Cycle: 1:1; Room Ambient Temperature: 25.0°C; Liquid Temperature: 24.0°C
Medium parameters used: $f = 5200$ MHz; $\sigma = 5.402$ mho/m; $\epsilon_r = 51.132$; $\rho = 1000$ kg/m³

DASY5 Configuration:

- Electronics: DAE3 Sn500; Calibrated: 7/14/2011
- Probe: EX3DV4 - SN3773; ConvF(4.15, 4.15, 4.15); Calibrated: 3/14/2012
- Sensor-Surface: 2.5mm (Mechanical Surface Detection)
- Phantom: ELI v5.0 (A); Type: QDOVA001BB; Serial: 1120

Body/5.2 GHz, Pin=100mW 2/Area Scan (7x7x1): Measurement grid: dx=10mm, dy=10mm
Maximum value of SAR (measured) = 13.343 mW/g

Body/5.2 GHz, Pin=100mW 2/Zoom Scan (8x8x10)/Cube 0: Measurement grid: dx=4mm, dy=4mm, dz=2.5mm
Reference Value = 52.955 V/m; Power Drift = 0.0014 dB
Peak SAR (extrapolated) = 26.2640
SAR(1 g) = 7.46 mW/g; SAR(10 g) = 2.13 mW/g
Maximum value of SAR (measured) = 13.102 mW/g

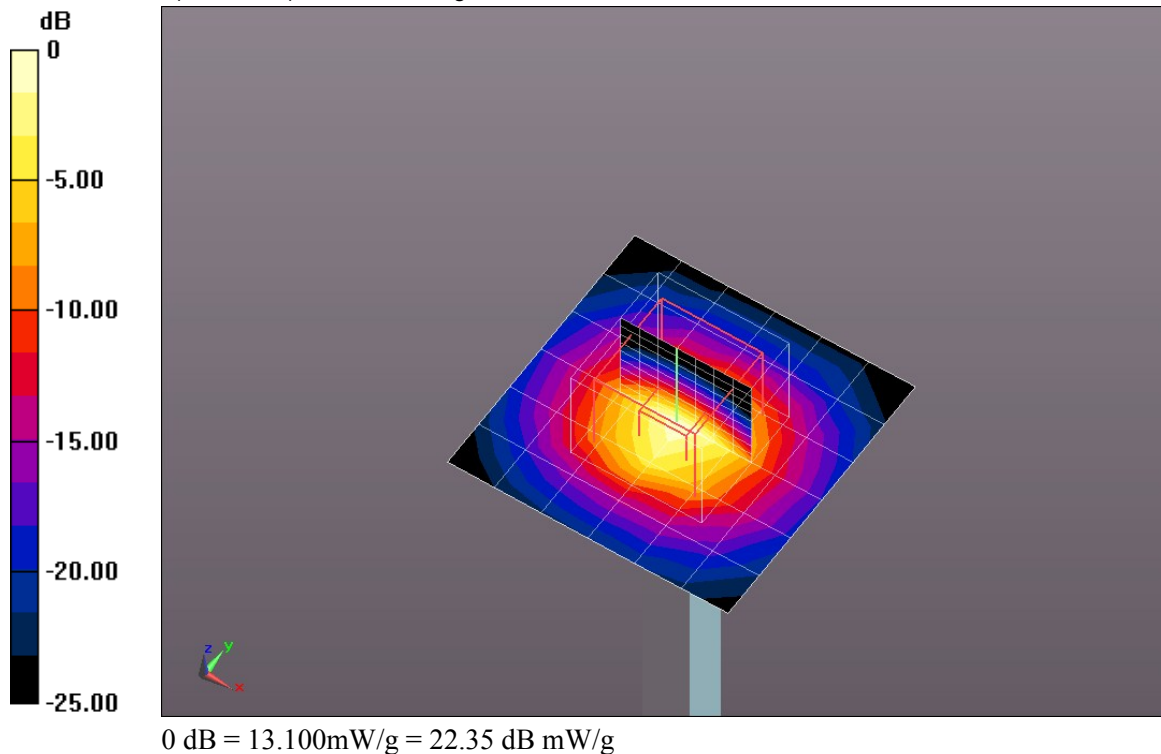

Test Laboratory: UL CCS SAR Lab C

Date: 5/12/2012

20120512_SystemPerformanceCheck-D5GHzV2 SN 1075

Frequency: 5200 MHz; Duty Cycle: 1:1

Body/5.2 GHz, Pin=100mW 2/Z Scan (1x1x21): Measurement grid: dx=20mm, dy=20mm, dz=5mm
Maximum value of SAR (measured) = 4.090 mW/g

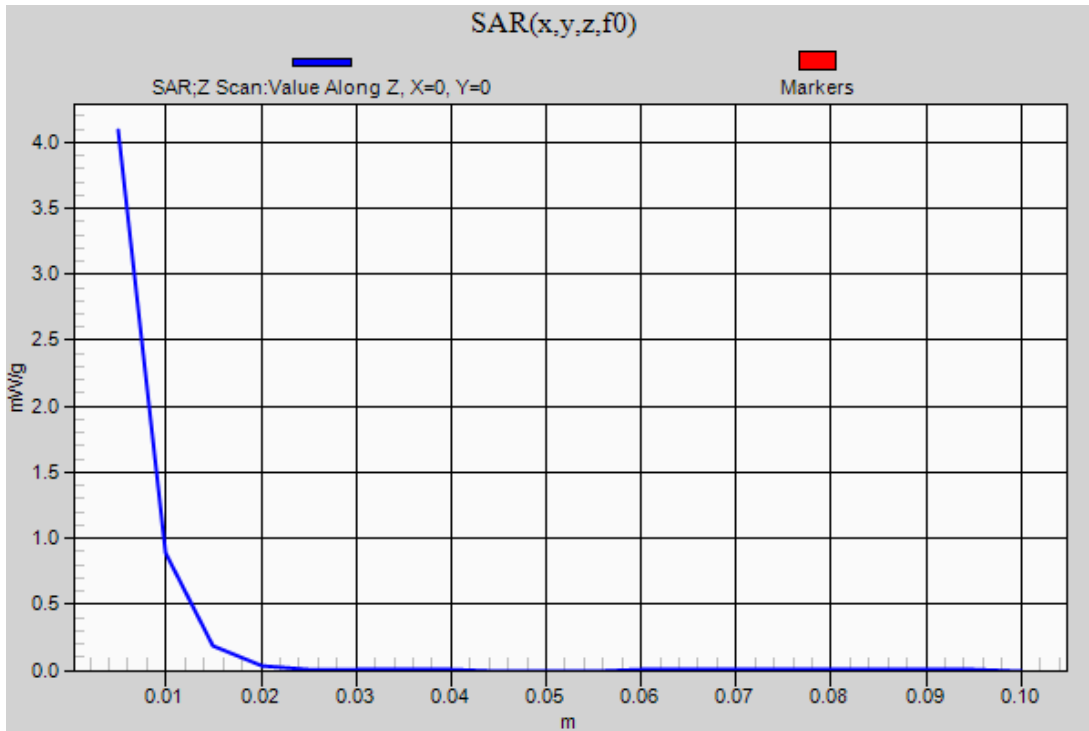

Test Laboratory: UL CCS SAR Lab C

Date: 5/12/2012

20120512_SystemPerformanceCheck-D5GHzV2 SN 1075

Frequency: 5800 MHz; Duty Cycle: 1:1; Room Ambient Temperature: 25.0°C; Liquid Temperature: 24.0°C
Medium parameters used: $f = 5800$ MHz; $\sigma = 6.212$ mho/m; $\epsilon_r = 50.037$; $\rho = 1000$ kg/m³

DASY5 Configuration:

- Electronics: DAE3 Sn500; Calibrated: 7/14/2011
- Probe: EX3DV4 - SN3773; ConvF(3.57, 3.57, 3.57); Calibrated: 3/14/2012
- Sensor-Surface: 2.5mm (Mechanical Surface Detection (Locations From Previous Scan Used)), Sensor-Surface: 2.5mm (Mechanical Surface Detection)
- Phantom: ELI v5.0 (A); Type: QDOVA001BB; Serial: 1120

Body/5.8 GHz, Pin=100mW/Area Scan (7x7x1): Measurement grid: dx=10mm, dy=10mm

Maximum value of SAR (measured) = 13.141 mW/g

Body/5.8 GHz, Pin=100mW/Zoom Scan (8x8x10)/Cube 0: Measurement grid: dx=4mm, dy=4mm, dz=2.5mm

Reference Value = 50.531 V/m; Power Drift = -0.02 dB

Peak SAR (extrapolated) = 25.9440

SAR(1 g) = 7.21 mW/g; SAR(10 g) = 2.04 mW/g

Maximum value of SAR (measured) = 13.311 mW/g

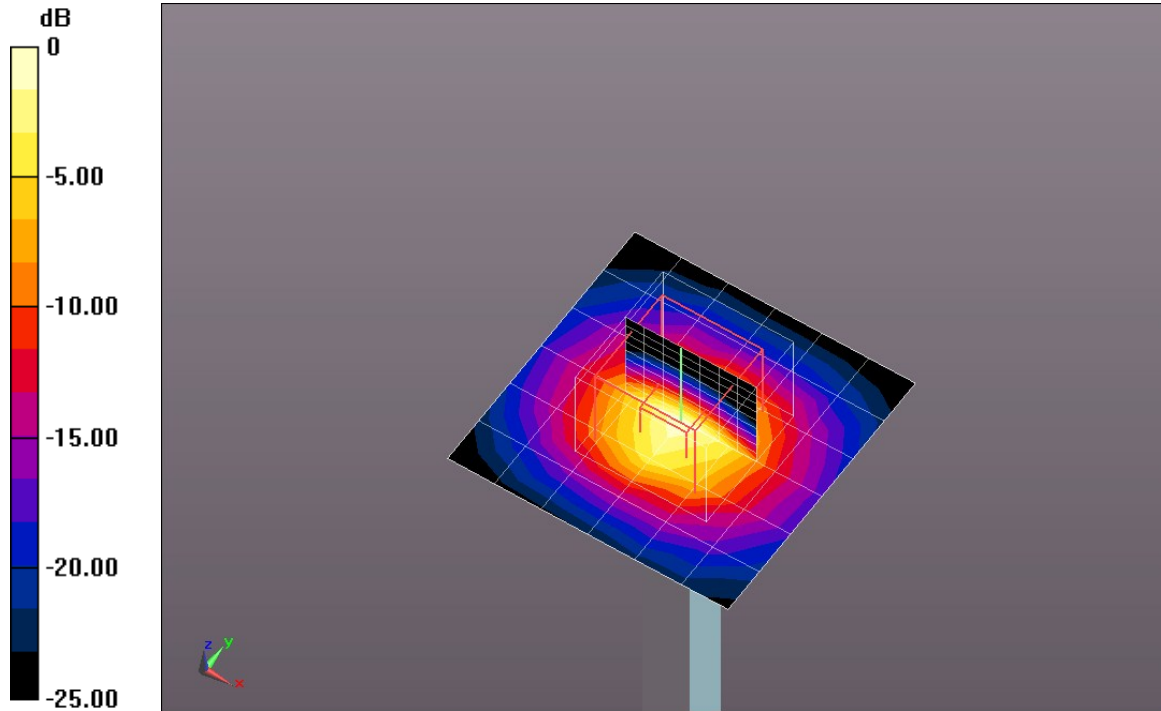

0 dB = 13.310mW/g = 22.48 dB mW/g

Test Laboratory: UL CCS SAR Lab C

Date: 5/12/2012

20120512_SystemPerformanceCheck-D5GHzV2 SN 1075

Frequency: 5800 MHz; Duty Cycle: 1:1

Body/5.8 GHz, Pin=100mW/Z Scan (1x1x21): Measurement grid: dx=20mm, dy=20mm, dz=5mm
Maximum value of SAR (measured) = 3.501 mW/g

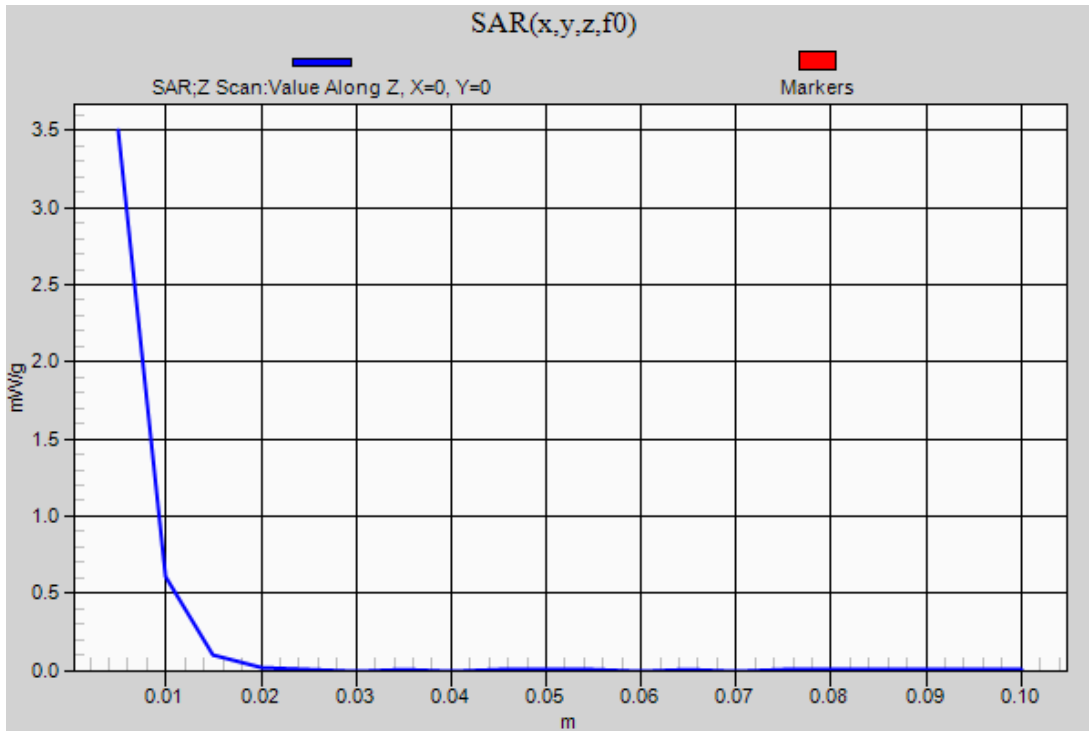

12. SAR Test Results

Main Antenna (ANT1V2) SAR Value

Test Position	Separation Distance (mm)	Mode	Band	Ch #	Freq. (MHz)	Avg.Pwr (dBm)	SAR (mW/g)		Note
							1-g	10-g	
Front	9	802.11a	5.2 GHz	40	5200	10.8	0.096	0.033	
				48	5240	10.8			1
			5.8 GHz	149	5745	10.9	0.088	0.029	
				157	5785	10.7			1
			165	5825	10.7			1	
Rear @ 15°	5	802.11a	5.2 GHz	40	5200	10.8	0.018	0.0074	
				48	5240	10.8			1
			5.8 GHz	149	5745	10.9	0.029	0.012	
				157	5785	10.7			1
			165	5825	10.7			1	
Edge 1	5	802.11a	5.2 GHz	40	5200	10.8	0.189	0.060	
				48	5240	10.8			1
			5.8 GHz	149	5745	10.9	0.187	0.058	
				157	5785	10.7			1
			165	5825	10.7			1	

Aux Antenna (ANT2V2) SAR Value

Test Position	Separation Distance (mm)	Mode	Band	Ch #	Freq. (MHz)	Avg. Pwr (dBm)	SAR (mW/g)		Note
							1-g	10-g	
Front	9	802.11a	5.2 GHz	40	5200	10.8	0.188	0.067	
				48	5240	10.8			1
			5.8 GHz	149	5745	10.9	0.173	0.060	
				157	5785	10.7			1
			165	5825	10.7			1	
Rear @ 15°	5	802.11a	5.2 GHz	40	5200	10.8	0.028	0.011	
				48	5240	10.8			1
			5.8 GHz	149	5745	10.9	0.028	0.011	
				157	5785	10.7			1
			165	5825	10.7			1	
Edge 1	5	802.11a	5.2 GHz	40	5200	10.8	0.552	0.177	
				48	5240	10.8			1
			5.8 GHz	149	5745	10.9	0.358	0.113	
				157	5785	10.7			1
			165	5825	10.7			1	

Note(s):

- For frequency bands with an operating range of < 100 MHz, when the SAR measured for the highest output power channel within is ≤ 0.8 W/kg, SAR for the remaining channels is not required. Per KDB 447498 1) e) i)
- A device to phantom separation distance of 9 mm was used to carry out testing for the Front Test Position because the analog joysticks protrude 9 mm upwards from the front surface, therefore preventing the use of the usual 5 mm separation distance.
- A device to phantom separation distance of 5 mm was used to carry out testing for the Rear @ 15° and Edge 1 test positions in accordance with KDB Inquiry #: 454638.

12.1. SAR Test Plots

Test Laboratory: UL CCS SAR Lab C

Date: 5/13/2012

WiFi 5GHz Bands

Frequency: 5200 MHz; Duty Cycle: 1:1; Room Ambient Temperature: 25.0°C; Liquid Temperature: 24.0°C
Medium parameters used: $f = 5200$ MHz; $\sigma = 5.402$ mho/m; $\epsilon_r = 51.132$; $\rho = 1000$ kg/m³

DASY5 Configuration:

- Electronics: DAE3 Sn500; Calibrated: 7/14/2011
- Probe: EX3DV4 - SN3773; ConvF(4.15, 4.15, 4.15); Calibrated: 3/14/2012
- Sensor-Surface: 2.5mm (Mechanical Surface Detection)
- Phantom: ELI v5.0 (A); Type: QDOVA001BB; Serial: 1120

Front/Main Ant. _802.11a_Ch 40/Area Scan (10x10x1): Measurement grid: dx=10mm, dy=10mm

Maximum value of SAR (measured) = 0.145 mW/g

Front/Main Ant. _802.11a_Ch 40/Zoom Scan (7x7x9)/Cube 0: Measurement grid: dx=4mm, dy=4mm, dz=2.5mm

Reference Value = 5.740 V/m; Power Drift = 0.13 dB

Peak SAR (extrapolated) = 0.2960

SAR(1 g) = 0.096 mW/g; SAR(10 g) = 0.033 mW/g

Maximum value of SAR (measured) = 0.158 mW/g

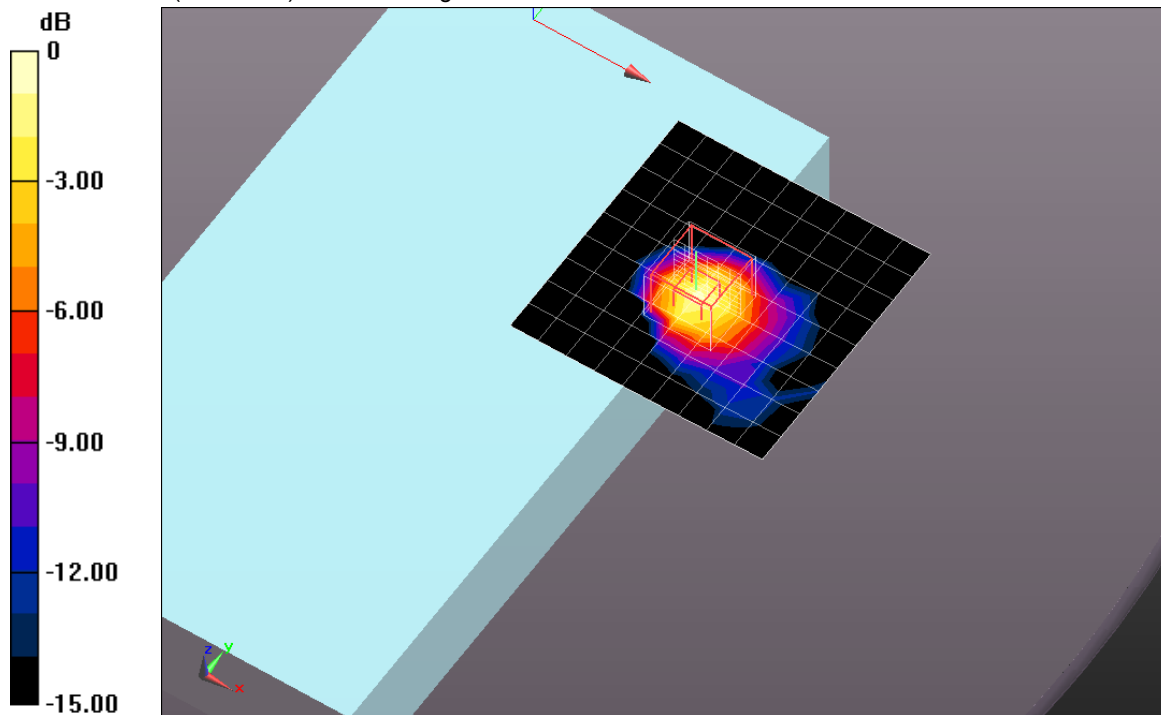

0 dB = 0.160mW/g = -15.92 dB mW/g

WiFi 5GHz Bands

Frequency: 5745 MHz; Duty Cycle: 1:1; Room Ambient Temperature: 25.0°C; Liquid Temperature: 24.0°C
Medium parameters used: $f = 5745 \text{ MHz}$; $\sigma = 6.127 \text{ mho/m}$; $\epsilon_r = 50.182$; $\rho = 1000 \text{ kg/m}^3$

DASY5 Configuration:

- Electronics: DAE3 Sn500; Calibrated: 7/14/2011
- Probe: EX3DV4 - SN3773; ConvF(3.57, 3.57, 3.57); Calibrated: 3/14/2012
- Sensor-Surface: 2.5mm (Mechanical Surface Detection (Locations From Previous Scan Used)), Sensor-Surface: 2.5mm (Mechanical Surface Detection)
- Phantom: ELI v5.0 (A); Type: QDOVA001BB; Serial: 1120

Front/Main Ant._802.11a_Ch 149/Area Scan (10x10x1): Measurement grid: $dx=10\text{mm}$, $dy=10\text{mm}$
Maximum value of SAR (measured) = 0.141 mW/g

Front/Main Ant._802.11a_Ch 149/Zoom Scan (7x7x9)/Cube 0: Measurement grid: $dx=4\text{mm}$, $dy=4\text{mm}$, $dz=2.5\text{mm}$
Reference Value = 5.110 V/m; Power Drift = 0.09 dB
Peak SAR (extrapolated) = 0.5830
SAR(1 g) = 0.088 mW/g; SAR(10 g) = 0.029 mW/g
Maximum value of SAR (measured) = 0.147 mW/g

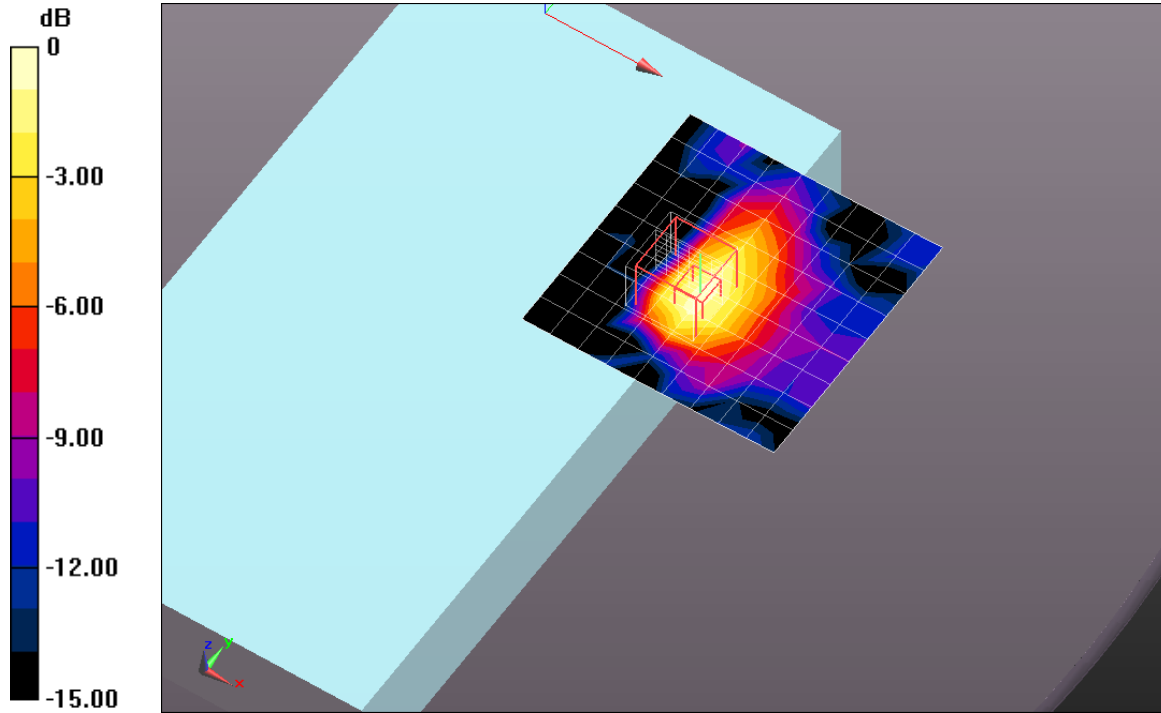

0 dB = 0.150mW/g = -16.48 dB mW/g

Test Laboratory: UL CCS SAR Lab C

Date: 5/12/2012

WiFi 5GHz Bands

Frequency: 5200 MHz; Duty Cycle: 1:1; Room Ambient Temperature: 25.0°C; Liquid Temperature: 24.0°C
Medium parameters used: $f = 5200$ MHz; $\sigma = 5.402$ mho/m; $\epsilon_r = 51.132$; $\rho = 1000$ kg/m³

DASY5 Configuration:

- Electronics: DAE3 Sn500; Calibrated: 7/14/2011
- Probe: EX3DV4 - SN3773; ConvF(4.15, 4.15, 4.15); Calibrated: 3/14/2012
- Sensor-Surface: 2.5mm (Mechanical Surface Detection)
- Phantom: ELI v5.0 (A); Type: QDOVA001BB; Serial: 1120

Rear @ 15 deg./Main Ant._802.11a_Ch 40/Area Scan (10x10x1): Measurement grid: dx=10mm, dy=10mm

Maximum value of SAR (measured) = 0.028 mW/g

Rear @ 15 deg./Main Ant._802.11a_Ch 40/Zoom Scan (9x9x9)/Cube 0: Measurement grid: dx=4mm, dy=4mm, dz=2.5mm

Reference Value = 2.510 V/m; Power Drift = 0.05 dB

Peak SAR (extrapolated) = 0.1990

SAR(1 g) = 0.018 mW/g; SAR(10 g) = 0.00774 mW/g

Maximum value of SAR (measured) = 0.035 mW/g

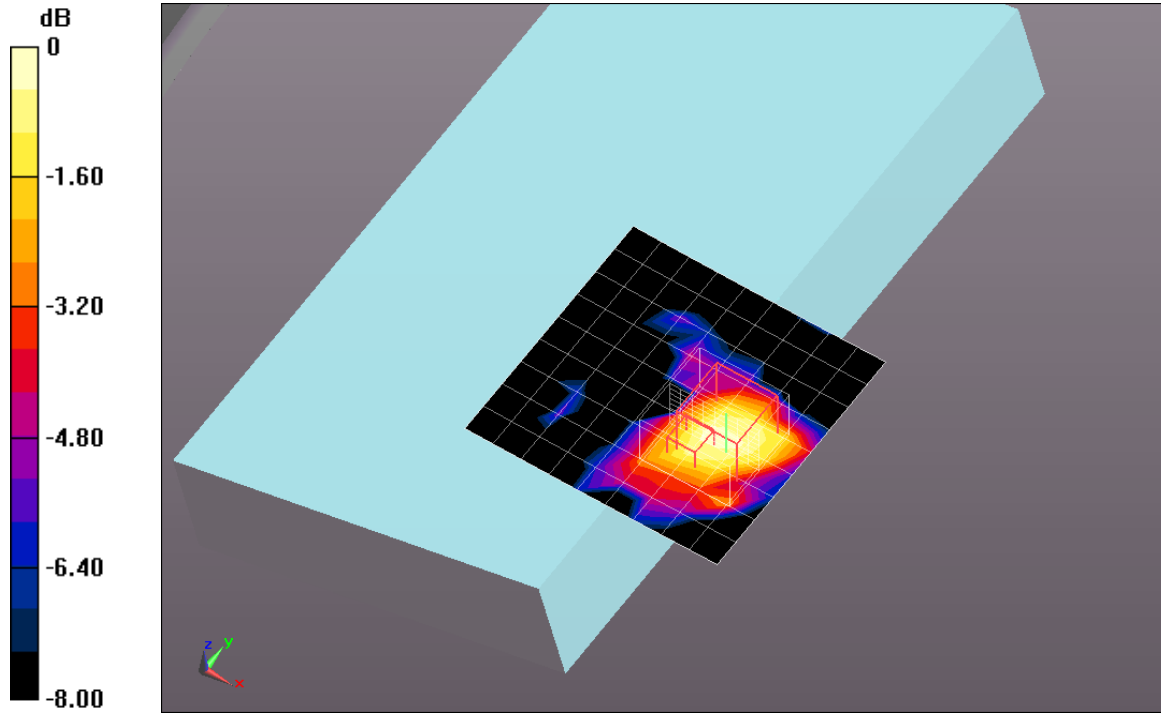

0 dB = 0.030mW/g = -30.46 dB mW/g

Test Laboratory: UL CCS SAR Lab C

Date: 5/12/2012

WiFi 5GHz Bands

Frequency: 5745 MHz; Duty Cycle: 1:1; Room Ambient Temperature: 25.0°C; Liquid Temperature: 24.0°C
Medium parameters used: $f = 5745$ MHz; $\sigma = 6.127$ mho/m; $\epsilon_r = 50.182$; $\rho = 1000$ kg/m³

DASY5 Configuration:

- Electronics: DAE3 Sn500; Calibrated: 7/14/2011
- Probe: EX3DV4 - SN3773; ConvF(3.57, 3.57, 3.57); Calibrated: 3/14/2012
- Sensor-Surface: 2.5mm (Mechanical Surface Detection (Locations From Previous Scan Used)), Sensor-Surface: 2.5mm (Mechanical Surface Detection)
- Phantom: ELI v5.0 (A); Type: QDOVA001BB; Serial: 1120

Rear @ 15 deg./Main Ant._802.11a_Ch 149/Area Scan (10x10x1): Measurement grid: dx=10mm, dy=10mm
Maximum value of SAR (measured) = 0.045 mW/g

Rear @ 15 deg./Main Ant._802.11a_Ch 149/Zoom Scan (9x9x9)/Cube 0: Measurement grid: dx=4mm, dy=4mm, dz=2.5mm
Reference Value = 2.558 V/m; Power Drift = 0.08 dB
Peak SAR (extrapolated) = 0.2640
SAR(1 g) = 0.029 mW/g; SAR(10 g) = 0.012 mW/g
Maximum value of SAR (measured) = 0.046 mW/g

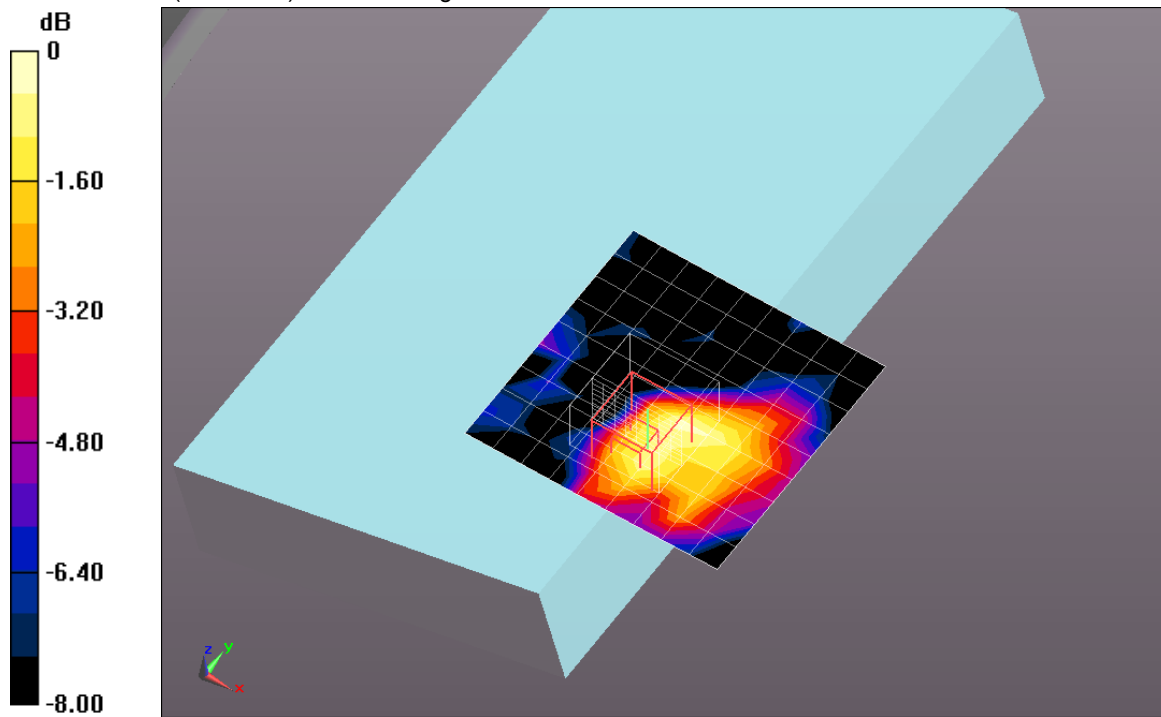

0 dB = 0.050mW/g = -26.02 dB mW/g

WiFi 5GHz Bands

Frequency: 5200 MHz; Duty Cycle: 1:1; Room Ambient Temperature: 25.0°C; Liquid Temperature: 24.0°C
Medium parameters used: $f = 5200$ MHz; $\sigma = 5.311$ mho/m; $\epsilon_r = 51.136$; $\rho = 1000$ kg/m³

DASY5 Configuration:

- Electronics: DAE3 Sn500; Calibrated: 7/14/2011
- Probe: EX3DV4 - SN3773; ConvF(4.15, 4.15, 4.15); Calibrated: 3/14/2012
- Sensor-Surface: 2.5mm (Mechanical Surface Detection (Locations From Previous Scan Used)), Sensor-Surface: 2.5mm (Mechanical Surface Detection)
- Phantom: ELI v5.0 (A); Type: QDOVA001BB; Serial: 1120

Edge 1/Main Ant._802.11a_Ch 40/Area Scan (10x10x1): Measurement grid: dx=10mm, dy=10mm
Maximum value of SAR (measured) = 0.290 mW/g

Edge 1/Main Ant._802.11a_Ch 40/Zoom Scan (7x7x9)/Cube 0: Measurement grid: dx=4mm, dy=4mm, dz=2.5mm

Reference Value = 7.989 V/m; Power Drift = 0.05 dB

Peak SAR (extrapolated) = 0.6490

SAR(1 g) = 0.189 mW/g; SAR(10 g) = 0.060 mW/g

Maximum value of SAR (measured) = 0.313 mW/g

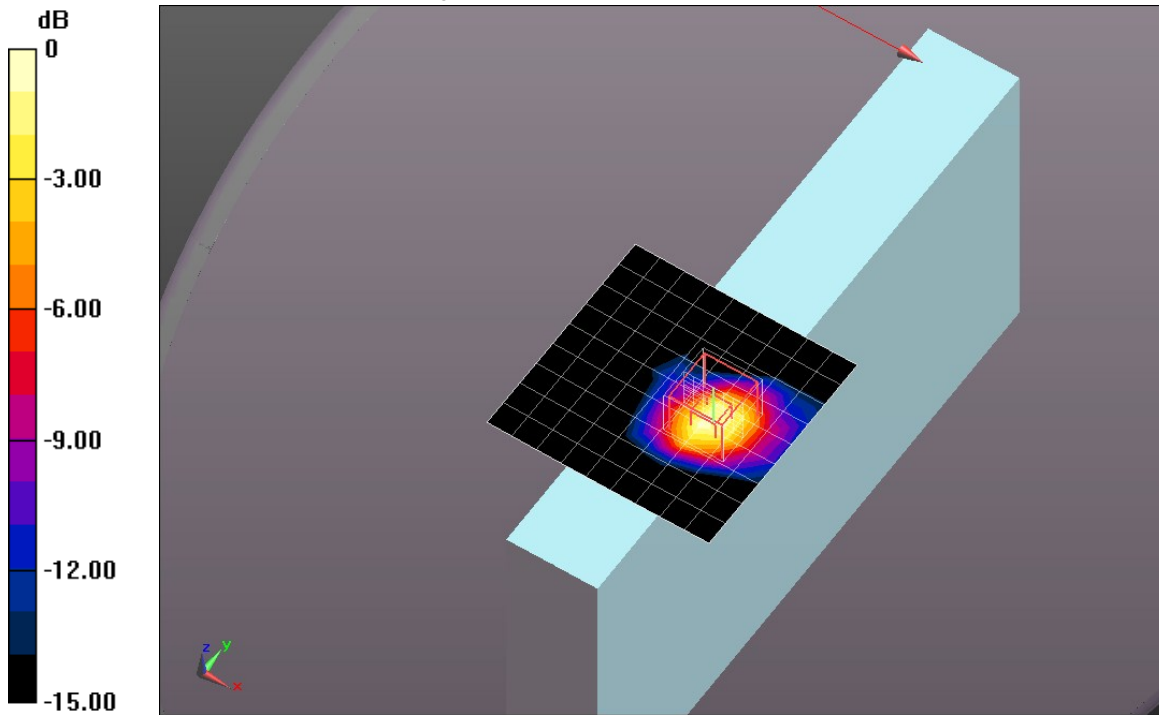

0 dB = 0.310mW/g = -10.17 dB mW/g

Test Laboratory: UL CCS SAR Lab C

Date: 5/11/2012

WiFi 5GHz Bands

Frequency: 5745 MHz; Duty Cycle: 1:1; Room Ambient Temperature: 25.0°C; Liquid Temperature: 24.0°C
Medium parameters used: $f = 5745$ MHz; $\sigma = 6.061$ mho/m; $\epsilon_r = 50.226$; $\rho = 1000$ kg/m³

DASY5 Configuration:

- Electronics: DAE3 Sn500; Calibrated: 7/14/2011
- Probe: EX3DV4 - SN3773; ConvF(3.57, 3.57, 3.57); Calibrated: 3/14/2012
- Sensor-Surface: 2.5mm (Mechanical Surface Detection (Locations From Previous Scan Used)), Sensor-Surface: 2.5mm (Mechanical Surface Detection)
- Phantom: ELI v5.0 (A); Type: QDOVA001BB; Serial: 1120

Edge 1/Main Ant._802.11a_Ch 149/Area Scan (10x10x1): Measurement grid: dx=10mm, dy=10mm
Maximum value of SAR (measured) = 0.264 mW/g

Edge 1/Main Ant._802.11a_Ch 149/Zoom Scan (7x7x9)/Cube 0: Measurement grid: dx=4mm, dy=4mm, dz=2.5mm
Reference Value = 7.447 V/m; Power Drift = -0.14 dB
Peak SAR (extrapolated) = 0.6740
SAR(1 g) = 0.187 mW/g; SAR(10 g) = 0.058 mW/g
Maximum value of SAR (measured) = 0.346 mW/g

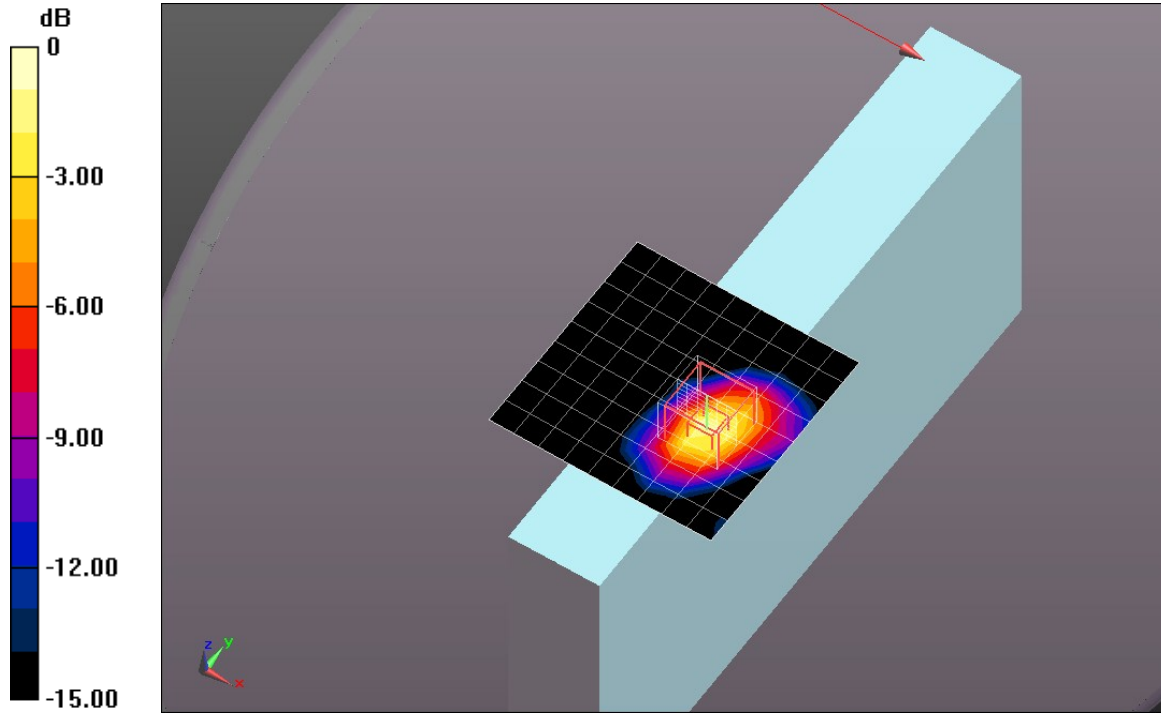

0 dB = 0.350mW/g = -9.12 dB mW/g

Test Laboratory: UL CCS SAR Lab C

Date: 5/13/2012

WiFi 5GHz Bands

Frequency: 5200 MHz; Duty Cycle: 1:1; Room Ambient Temperature: 25.0°C; Liquid Temperature: 24.0°C
Medium parameters used: $f = 5200$ MHz; $\sigma = 5.402$ mho/m; $\epsilon_r = 51.132$; $\rho = 1000$ kg/m³

DASY5 Configuration:

- Electronics: DAE3 Sn500; Calibrated: 7/14/2011
- Probe: EX3DV4 - SN3773; ConvF(4.15, 4.15, 4.15); Calibrated: 3/14/2012
- Sensor-Surface: 2.5mm (Mechanical Surface Detection (Locations From Previous Scan Used)), Sensor-Surface: 2.5mm (Mechanical Surface Detection)
- Phantom: ELI v5.0 (A); Type: QDOVA001BB; Serial: 1120

Front/Aux Ant._802.11a_Ch 40/Area Scan (10x10x1): Measurement grid: dx=10mm, dy=10mm
Maximum value of SAR (measured) = 0.266 mW/g

Front/Aux Ant._802.11a_Ch 40/Zoom Scan (7x7x9)/Cube 0: Measurement grid: dx=4mm, dy=4mm, dz=2.5mm
Reference Value = 7.175 V/m; Power Drift = 0.12 dB
Peak SAR (extrapolated) = 0.5740
SAR(1 g) = 0.188 mW/g; SAR(10 g) = 0.067 mW/g
Maximum value of SAR (measured) = 0.314 mW/g

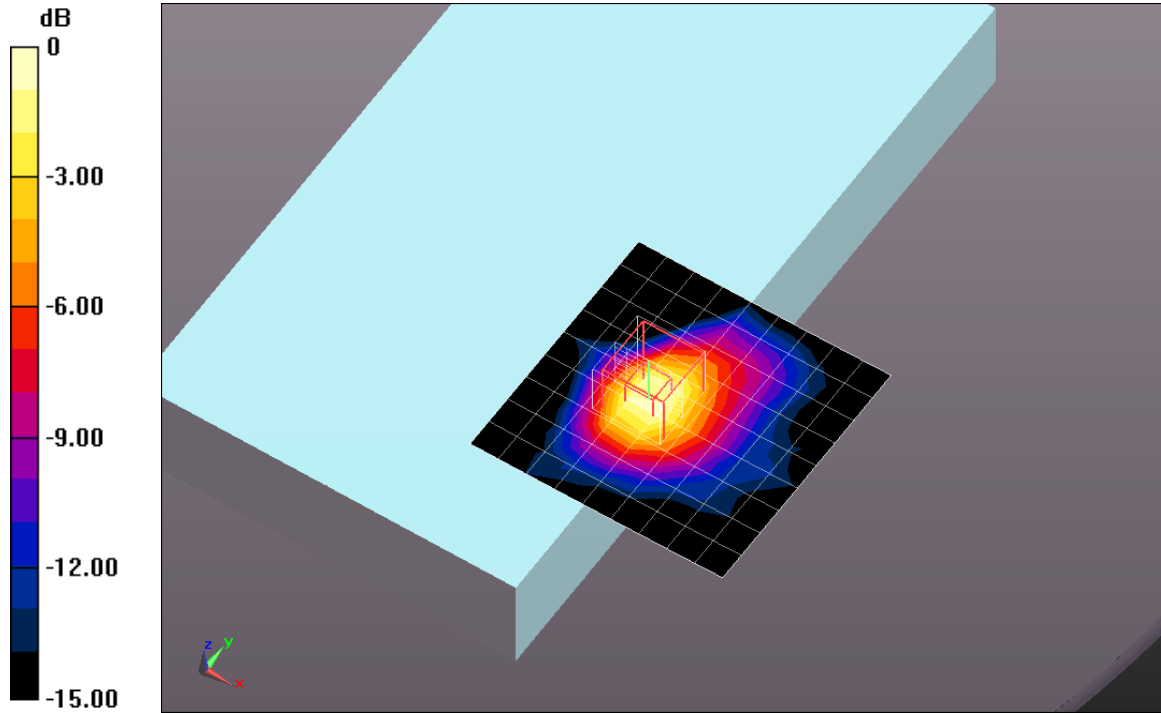

0 dB = 0.310mW/g = -10.17 dB mW/g

Test Laboratory: UL CCS SAR Lab C

Date: 5/13/2012

WiFi 5GHz Bands

Frequency: 5745 MHz; Duty Cycle: 1:1; Room Ambient Temperature: 25.0°C; Liquid Temperature: 24.0°C
Medium parameters used: $f = 5745$ MHz; $\sigma = 6.127$ mho/m; $\epsilon_r = 50.182$; $\rho = 1000$ kg/m³

DASY5 Configuration:

- Electronics: DAE3 Sn500; Calibrated: 7/14/2011
- Probe: EX3DV4 - SN3773; ConvF(3.57, 3.57, 3.57); Calibrated: 3/14/2012
- Sensor-Surface: 2.5mm (Mechanical Surface Detection)
- Phantom: ELI v5.0 (A); Type: QDOVA001BB; Serial: 1120

Front/Aux Ant. _802.11a_Ch 149/Area Scan (10x10x1): Measurement grid: dx=10mm, dy=10mm
Maximum value of SAR (measured) = 0.238 mW/g

Front/Aux Ant. _802.11a_Ch 149/Zoom Scan (7x7x9)/Cube 0: Measurement grid: dx=4mm, dy=4mm, dz=2.5mm
Reference Value = 6.967 V/m; Power Drift = -0.11 dB
Peak SAR (extrapolated) = 0.5580
SAR(1 g) = 0.173 mW/g; SAR(10 g) = 0.060 mW/g
Maximum value of SAR (measured) = 0.286 mW/g

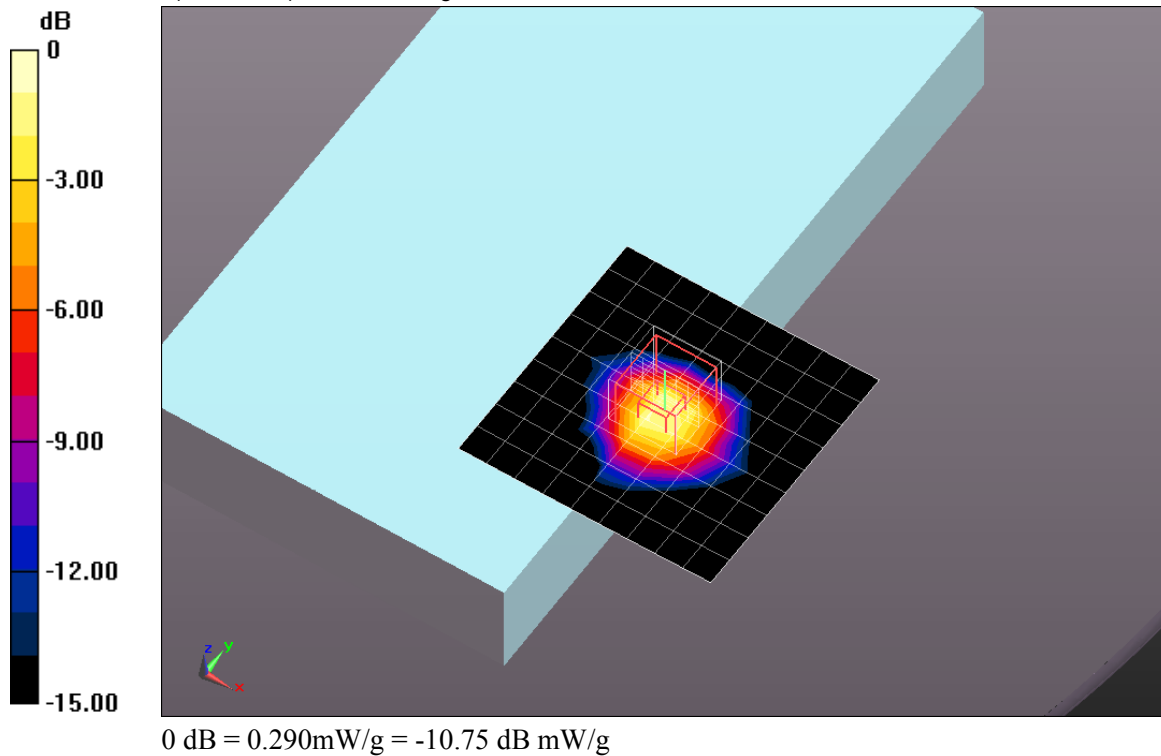

Test Laboratory: UL CCS SAR Lab C

Date: 5/12/2012

WiFi 5GHz Bands

Frequency: 5200 MHz; Duty Cycle: 1:1; Room Ambient Temperature: 25.0°C; Liquid Temperature: 24.0°C
Medium parameters used: $f = 5200$ MHz; $\sigma = 5.402$ mho/m; $\epsilon_r = 51.132$; $\rho = 1000$ kg/m³

DASY5 Configuration:

- Electronics: DAE3 Sn500; Calibrated: 7/14/2011
- Probe: EX3DV4 - SN3773; ConvF(4.15, 4.15, 4.15); Calibrated: 3/14/2012
- Sensor-Surface: 2.5mm (Mechanical Surface Detection)
- Phantom: ELI v5.0 (A); Type: QDOVA001BB; Serial: 1120

Rear @ 15 deg./Aux Ant._802.11a_Ch 40/Area Scan (10x10x1): Measurement grid: dx=10mm, dy=10mm

Maximum value of SAR (measured) = 0.051 mW/g

Rear @ 15 deg./Aux Ant._802.11a_Ch 40/Zoom Scan (9x9x9)/Cube 0: Measurement grid: dx=4mm, dy=4mm, dz=2.5mm

Reference Value = 3.353 V/m; Power Drift = 0.17 dB

Peak SAR (extrapolated) = 0.1870

SAR(1 g) = 0.028 mW/g; SAR(10 g) = 0.011 mW/g

Maximum value of SAR (measured) = 0.050 mW/g

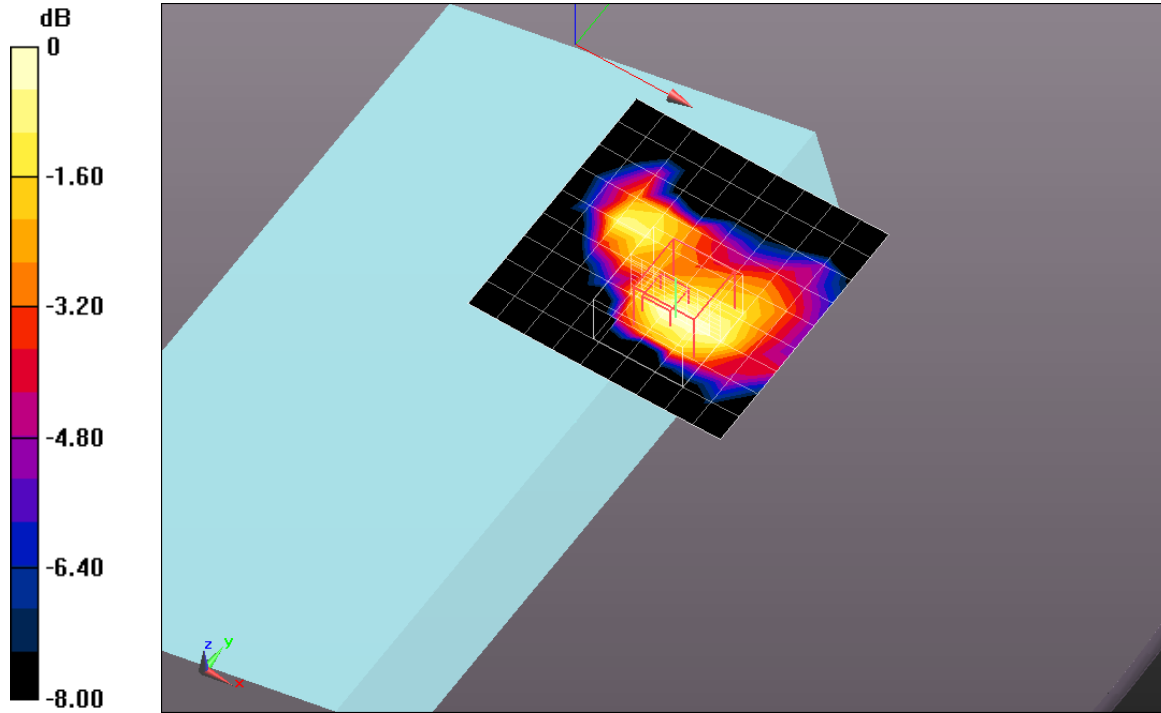

0 dB = 0.050mW/g = -26.02 dB mW/g

Test Laboratory: UL CCS SAR Lab C

Date: 5/12/2012

WiFi 5GHz Bands

Frequency: 5745 MHz; Duty Cycle: 1:1; Room Ambient Temperature: 25.0°C; Liquid Temperature: 24.0°C
Medium parameters used: $f = 5745 \text{ MHz}$; $\sigma = 6.127 \text{ mho/m}$; $\epsilon_r = 50.182$; $\rho = 1000 \text{ kg/m}^3$

DASY5 Configuration:

- Electronics: DAE3 Sn500; Calibrated: 7/14/2011
- Probe: EX3DV4 - SN3773; ConvF(3.57, 3.57, 3.57); Calibrated: 3/14/2012
- Sensor-Surface: 2.5mm (Mechanical Surface Detection (Locations From Previous Scan Used)), Sensor-Surface: 2.5mm (Mechanical Surface Detection)
- Phantom: ELI v5.0 (A); Type: QDOVA001BB; Serial: 1120

Rear @ 15 deg./Aux Ant._802.11a_Ch 149/Area Scan (10x10x1): Measurement grid: $dx=10\text{mm}$, $dy=10\text{mm}$
Maximum value of SAR (measured) = 0.069 mW/g

Rear @ 15 deg./Aux Ant._802.11a_Ch 149/Zoom Scan (9x9x9)/Cube 0: Measurement grid: $dx=4\text{mm}$, $dy=4\text{mm}$, $dz=2.5\text{mm}$
Reference Value = 3.044 V/m; Power Drift = 0.13 dB
Peak SAR (extrapolated) = 0.1700
SAR(1 g) = 0.028 mW/g; SAR(10 g) = 0.011 mW/g
Maximum value of SAR (measured) = 0.051 mW/g

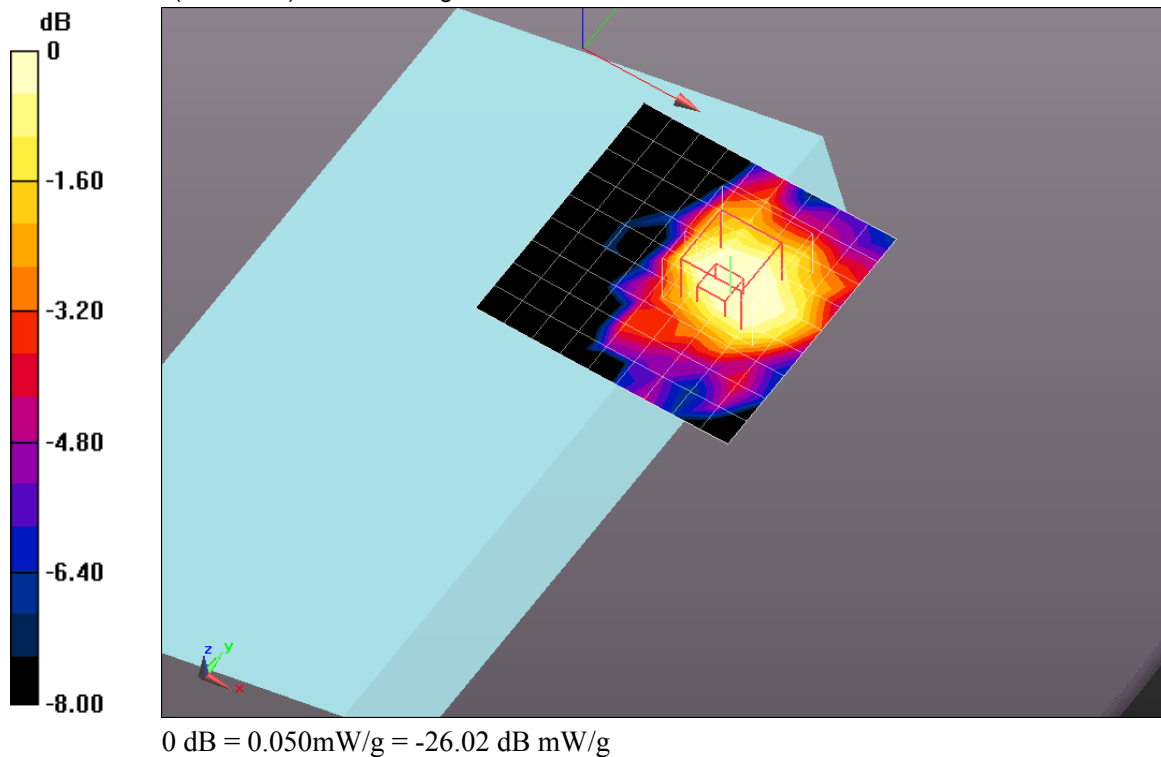

Test Laboratory: UL CCS SAR Lab C

Date: 5/11/2012

WiFi 5GHz Bands

Frequency: 5745 MHz; Duty Cycle: 1:1; Room Ambient Temperature: 25.0°C; Liquid Temperature: 24.0°C
Medium parameters used: $f = 5745$ MHz; $\sigma = 6.061$ mho/m; $\epsilon_r = 50.226$; $\rho = 1000$ kg/m³

DASY5 Configuration:

- Electronics: DAE3 Sn500; Calibrated: 7/14/2011
- Probe: EX3DV4 - SN3773; ConvF(3.57, 3.57, 3.57); Calibrated: 3/14/2012
- Sensor-Surface: 2.5mm (Mechanical Surface Detection (Locations From Previous Scan Used)), Sensor-Surface: 2.5mm (Mechanical Surface Detection)
- Phantom: ELI v5.0 (A); Type: QDOVA001BB; Serial: 1120

Edge 1/Aux Ant._802.11a_Ch 40/Area Scan (10x10x1): Measurement grid: dx=10mm, dy=10mm
Maximum value of SAR (measured) = 0.820 mW/g

Edge 1/Aux Ant._802.11a_Ch 40/Zoom Scan (7x7x9)/Cube 0: Measurement grid: dx=4mm, dy=4mm, dz=2.5mm

Reference Value = 13.011 V/m; Power Drift = 0.03 dB

Peak SAR (extrapolated) = 1.7730

SAR(1 g) = 0.552 mW/g; SAR(10 g) = 0.177 mW/g

Maximum value of SAR (measured) = 0.937 mW/g

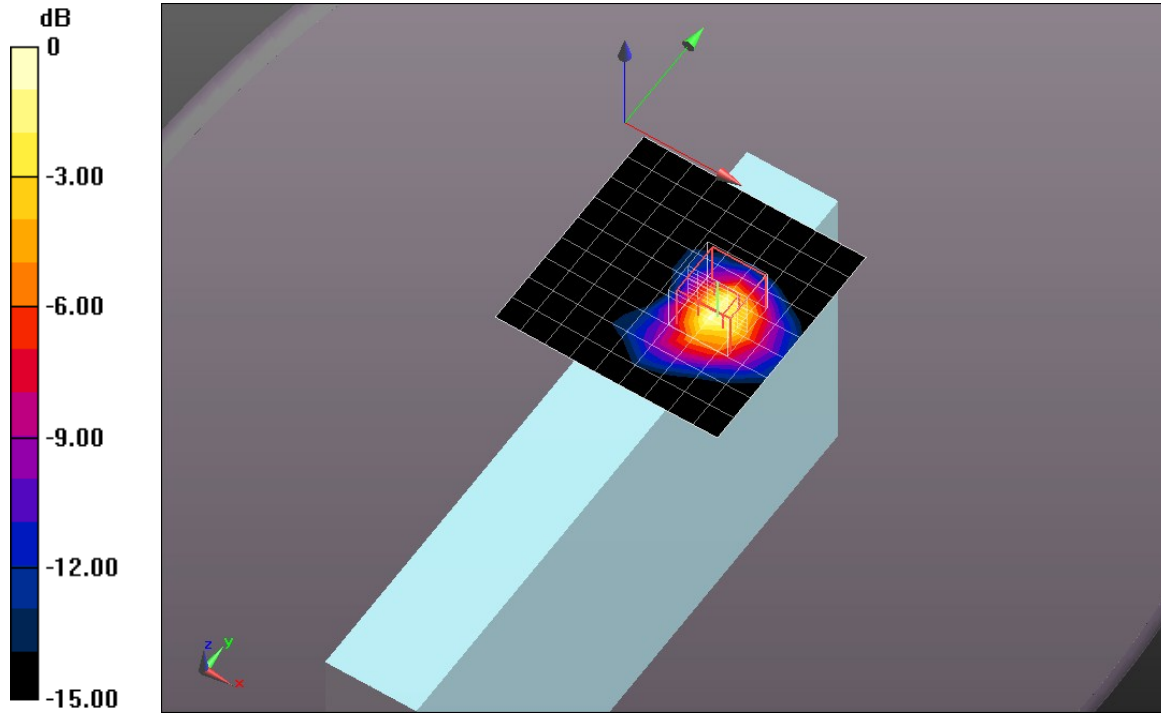

0 dB = 0.940mW/g = -0.54 dB mW/g

Test Laboratory: UL CCS SAR Lab C

Date: 5/11/2012

WiFi 5GHz Bands

Frequency: 5745 MHz; Duty Cycle: 1:1

Edge 1/Aux Ant._802.11a_Ch 40/Z Scan (1x1x21): Measurement grid: dx=20mm, dy=20mm, dz=5mm
Maximum value of SAR (measured) = 0.870 mW/g

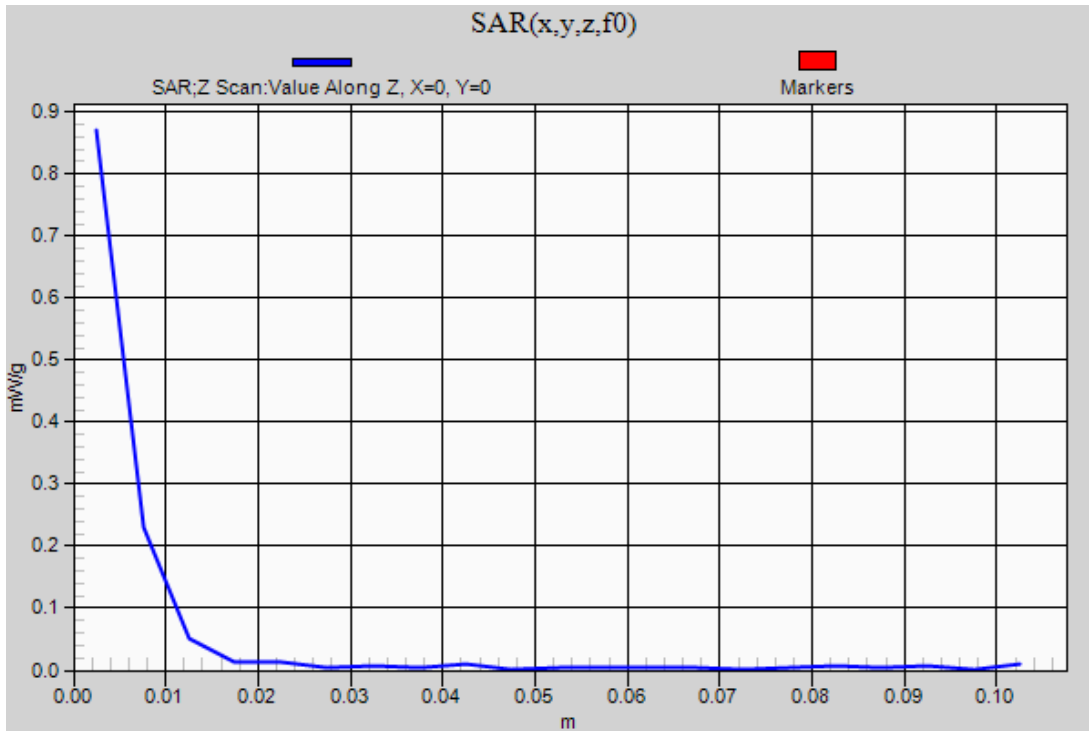

Test Laboratory: UL CCS SAR Lab C

Date: 5/11/2012

WiFi 5GHz Bands

Frequency: 5745 MHz; Duty Cycle: 1:1; Room Ambient Temperature: 25.0°C; Liquid Temperature: 24.0°C
Medium parameters used: $f = 5745 \text{ MHz}$; $\sigma = 6.061 \text{ mho/m}$; $\epsilon_r = 50.226$; $\rho = 1000 \text{ kg/m}^3$

DASY5 Configuration:

- Electronics: DAE3 Sn500; Calibrated: 7/14/2011
- Probe: EX3DV4 - SN3773; ConvF(3.57, 3.57, 3.57); Calibrated: 3/14/2012
- Sensor-Surface: 2.5mm (Mechanical Surface Detection (Locations From Previous Scan Used)), Sensor-Surface: 2.5mm (Mechanical Surface Detection)
- Phantom: ELI v5.0 (A); Type: QDOVA001BB; Serial: 1120

Edge 1/Aux Ant._802.11a_Ch 149/Area Scan (10x10x1): Measurement grid: $dx=10\text{mm}$, $dy=10\text{mm}$
Maximum value of SAR (measured) = 0.533 mW/g

Edge 1/Aux Ant._802.11a_Ch 149/Zoom Scan (7x7x9)/Cube 0: Measurement grid: $dx=4\text{mm}$, $dy=4\text{mm}$, $dz=2.5\text{mm}$
Reference Value = 10.278 V/m; Power Drift = 0.11 dB
Peak SAR (extrapolated) = 1.2040
SAR(1 g) = 0.358 mW/g; SAR(10 g) = 0.113 mW/g
Maximum value of SAR (measured) = 0.644 mW/g

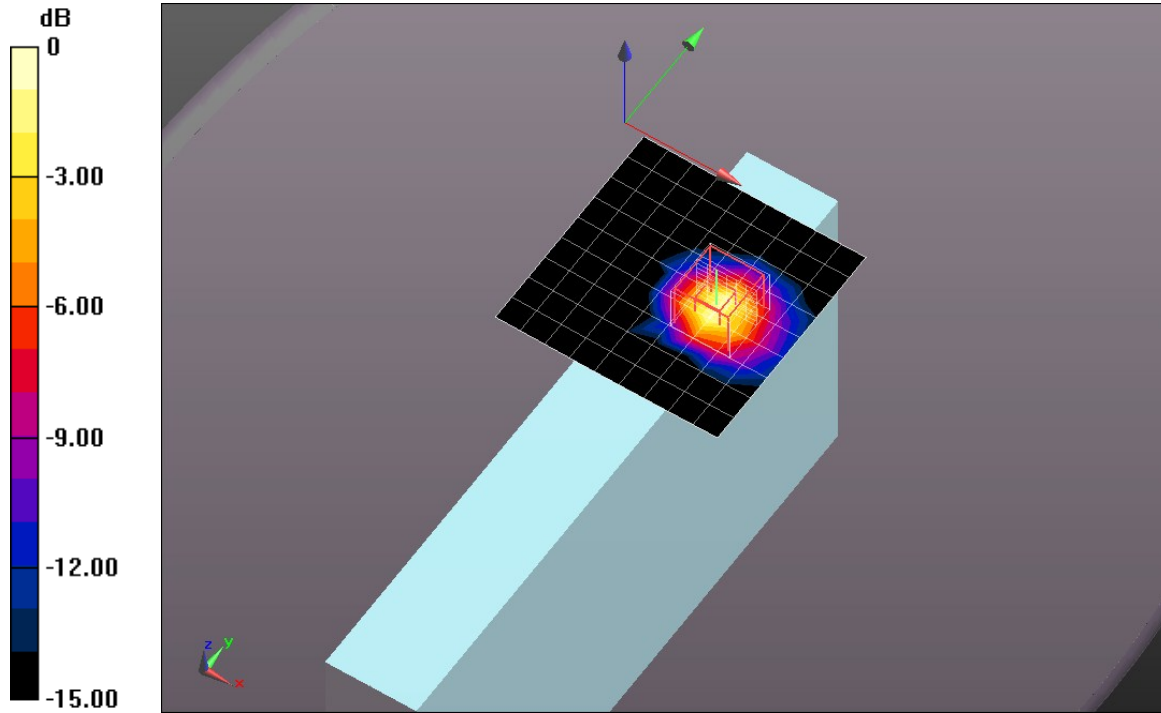

0 dB = 0.640mW/g = -3.88 dB mW/g

Test Laboratory: UL CCS SAR Lab C

Date: 5/11/2012

WiFi 5GHz Bands

Frequency: 5745 MHz; Duty Cycle: 1:1

Edge 1/Aux Ant. _802.11a_Ch 149/Z Scan (1x1x21): Measurement grid: dx=20mm, dy=20mm, dz=5mm
Maximum value of SAR (measured) = 0.553 mW/g

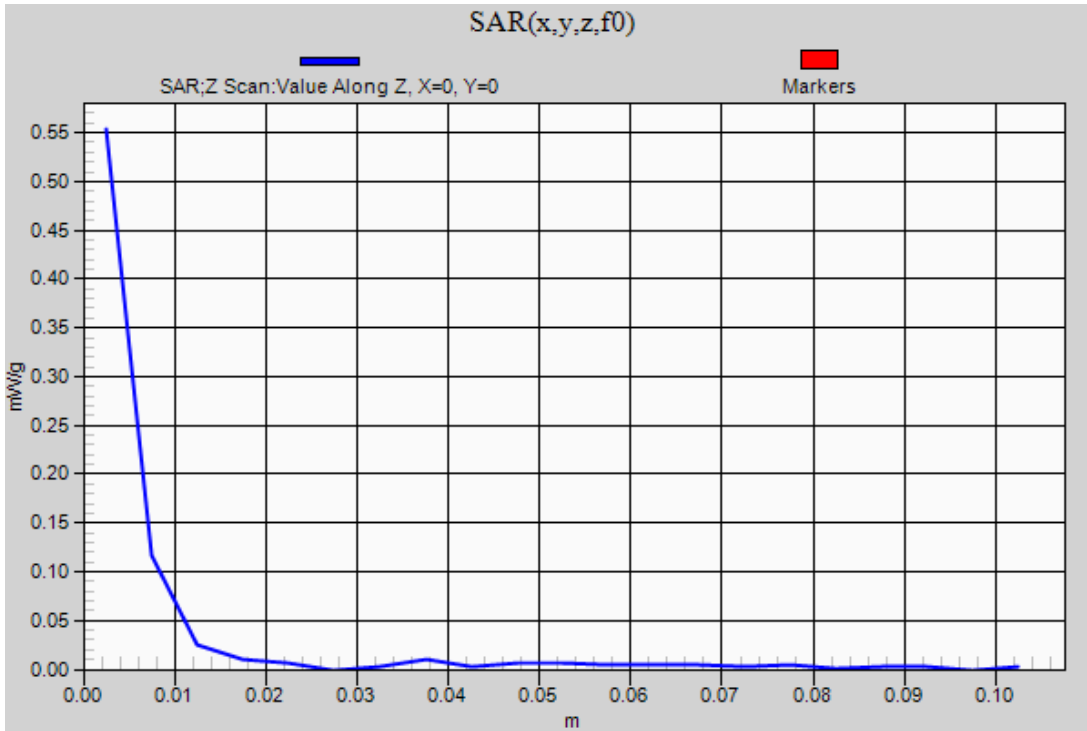

13. Appendixes

Refer to separated files for the following appendixes.

13.1. Calibration Certificate for E-Field Probe EX3DV4 SN 3773

13.2. Calibration Certificate for D5GHzV2 SN 1075