



Wireless Local Area Network Campus BridgeLINK™ User Guide

Notices

FCC

This equipment has been tested and found to comply with the limits for a Class A digital device, pursuant to Part 15 of the FCC rules. These limits are designed to provide reasonable protection against harmful interference in a residential installation. This equipment generates, uses, and can radiate radio frequency energy and, if not installed and used in accordance with the instructions, may cause harmful interference to radio communications. However, there is no guarantee that interference will not occur in a particular installation. If this equipment does cause harmful interference to radio or television reception, which can be determined by turning the equipment off and on, the user is encouraged to try to correct the interference by one of the following measures:

- Reorient or relocate the receiving antenna.
- Increase the separation between the equipment and receiver.
- Connect the equipment into an outlet on a circuit different from that to which the receiver is connected.
- Consult the dealer or an experienced radio/TV technician for help.

FCCID: MCIPUNIIT

FCC Rule Part(s): 15

Frequency (MHz): 5775, 5200, 5300

Equipment Class Low Power Communication Device Transmitter

Remarks:

UNII WLAN and Class A PCMCIA Card

Maximum Output Power: 50 mW

Notes:

This device has shown compliance with new rules adopted under Docket 87-389 and is not affected by Section 15.37, transition rule.

Each radio is marked with its operating frequency.

FCC regulations require that this device be professionally installed by a person knowledgeable in electronics and trained in the correct installation of this device.

UL safety listing requires that the installation conform to the National Electrical Code sections 810 and 820.

All interface cables must be shielded.

This device complies with Part 15 of FCC rules. Operation is subject to the following two conditions: 1) this device may not cause harmful interference, and 2) this device must accept any interference received, including interference that may cause undesired operation.

Disclaimer

The instructions in this document have been carefully checked for accuracy and are presumed to be reliable. RadioLAN and its writers assume no responsibility for inaccuracies and reserve the right to modify and revise this document without notice.

It is always our goal at RadioLAN to supply accurate and reliable documentation. If you discover a discrepancy in this document, please e-mail your comments or suggested corrections to *marketing@radiolan.com*.

No part of this publication may be placed in a retrieval system, transmitted, or reproduced in any way, including, but not limited to, photograph, photocopy, computer disk or other record, without prior agreement and written permission from:

RadioLAN
455 De Guigne Drive
Sunnyvale, CA 94086

© 1999 RadioLAN, Sunnyvale, CA, USA. All rights reserved.

Trademark Disclosures

RadioLAN has made every effort to provide disclosures when using trademarks owned by other companies. Trademarked designations appear throughout this publication. The publisher states that it is using the designations only for editorial purposes, and to the benefit of the trademark owner with no intent to infringe upon that trademark. The following trademarks are found in this manual:

Microsoft™, Windows for Workgroups™, Windows 95™, Microsoft Internet Explorer™, and Windows NT™ are trademarks of Microsoft Corporation.

Netscape™ is a registered trademark of The Netscape Corporation;
Novell™ and NetWare™ are trademarks of Novell, Inc.

Xerox™ is a trademark of Xerox Corporation.

IBM™ is a trademark of International Business Machines.

10BaseRadio™ and RadioLAN/10™ are trademarks of Radio/LAN.

Java™ is a trademark of Sun Microsystems, Inc.

Manual Conventions

The following text formats are used throughout this manual:

References to other locations in the manual or to other manuals provided by RadioLAN are *italicized*.

Narrow Bold Letters describe buttons and fields on the screen.

SMALL CAPITAL LETTERS describe Screen Names or Screen Tab Names.

Bold and Italicized Letters indicate important information.

Table of Contents

Notices	ii
FCC.....	ii
Disclaimer	iv
Trademark Disclosures	v
Manual Conventions	v
Introduction	1
The Campus BridgeLINK™ System.....	3
The Directional Antenna.....	8
A Typical Campus BridgeLINK™ Application	10
Determining the Distance between Buildings	11
Initial IP Address Setup	12
Installing the CPU	15
Tools You Will Need	15
Locating the CPU	16
Mounting the CPU	17
Grounding Considerations.....	20
Installing the Antenna.....	21

A Brief Word About Safety.....	21
Choosing the Best Mounting Height.....	22
Sighting Each Campus BridgeLINK™ Antenna.....	23
Apply Power to the CPU.....	25
Adding Security to the Wireless Network.....	26
Local Management.....	26
Dual Remote Management: HTML and SNMP.....	26
Using the Campus BridgeLINK™ Manager.....	28
The CPU Web Site.....	28
Browsing the Network for the CPU.....	29
Logging onto Campus BridgeLINK™ Manager.....	29
Campus BridgeLINK™ Manager Site Layout.....	31
Aiming the Directional Antennas.....	33
Setting Up Security Features.....	35
Setting Up SNMP Capabilities.....	36
Setting the CPU's Mode of Operation.....	47
Securing the CPU with Data Encryption.....	48
Bridging the Link and 10BaseT Networks.....	49
Managing Packet Flow Through the CPU.....	57
Interrogating the System for Performance Information.....	67
Upgrading System Software.....	74
Saving or Rejecting Configuration Setting Changes.....	77
Resetting the CPU.....	79

Recording Important System Information	80
Viewing the System Log.....	83
Managing the CPU Locally	84
CPU Local Management.....	86
Hot Keys.....	86
Logging onto the CPU Configuration Screen.....	87
Using the Main Menu	89
Working with the System Configuration Menu.....	91
Configuration Manager Menu Items	95
Troubleshooting	109
Glossary	111
Appendix A: Indicators, Switches, and Connectors	115
Indicators	115
MDI/MDI-X Switch	116
I/O Connectors	117
Serial Port Connector	118
Appendix B: Technical Specifications	119
Network Protocol	119
Standards Support.....	119

Electrical Specifications.....	119
Physical Specifications.....	120
Environmental Specifications.....	120
Electromagnetic Emissions	121
Safety Agency Approvals	121
Getting Technical Support.....	122

Notes

Introduction

Historically, connecting two buildings to allow networking between two local area networks required the expense and effort related to running a cable from one building to another. This may have involved installing an aerial cable or digging a trench and installing conduit and wiring between the two buildings, which is time-consuming, labor-intensive, and costly.

After installation, cable degradation, due to moisture, corrosion, or alterations in landscaping, can compromise the network connection between the two buildings. Repairing and replacing cable runs is also costly, time-consuming, and labor-intensive.

RadioLAN overcomes these difficult installation issues with its Campus BridgeLINK™ product line. This exciting new technology easily connects two buildings, using radio frequency technology. Because this technology uses radio frequency to make the connection between the buildings, cable runs, conduit, trenching, and labor involved with these activities are no longer required.

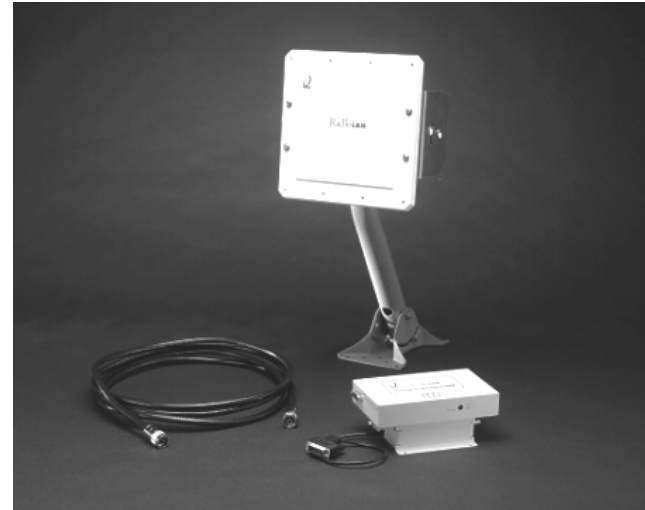

Figure 1: Campus BridgeLINK™ Products

RadioLAN allows you to connect two buildings, which are up to one mile apart, using a Campus BridgeLINK™ Processor Unit (CPU), a Companion Radio Module (CRM), and an 8.86" square directional antenna for each building link. When using the Campus BridgeLINK™ application, you need only install the components at each building, aim the antennas toward one another, and power the system on. The only requirements for each building location are Campus BridgeLINK™ system components and access to network cabling and power.

The directional antenna and its cabling is weatherproof, small-profile, and sturdy. Because the directional antenna allows for a 19° angle of operation, aiming the antennas so they point toward one another is nearly effortless.

Connecting two networks in two locations using the old-fashioned, hard-wired method could take days, considering the labor intensive effort needed. When using Campus BridgeLINK, the task is simplified. The task of connecting two networks is reduced to mere hours, without the back-breaking labor related to trenching, laying conduit and then cleaning up the landscaping mess afterward.

In this section, we will introduce you to the concepts of Campus BridgeLINK™ communication, using a RadioLAN Wireless Campus BridgeLINK™ system. Here, you will become familiar with the CPU, the CRM, the directional antenna, and the signal analysis tools.

The Campus BridgeLINK™ System

The Campus BridgeLINK system includes the Campus BridgeLINK™ Processor Unit (CPU) with a mounting bracket, a Companion Radio Module (CRM), and a directional antenna. Also included is the power transformer that you can plug into a non-switched electric outlet. You can install these items in plain view, hidden away in a closet, or above ceiling tile.

Campus BridgeLINK™ Processor Unit (CPU)

The CPU features a number of LED indicators, switches, and jacks that allows you to connect the module to external devices and help you see the CPU status.

LED Indicators

The face of the CPU features four LED indicators:

- The green Power LED illuminates when power is applied to the CPU. As long as the CPU is powered, this LED is normally illuminated.

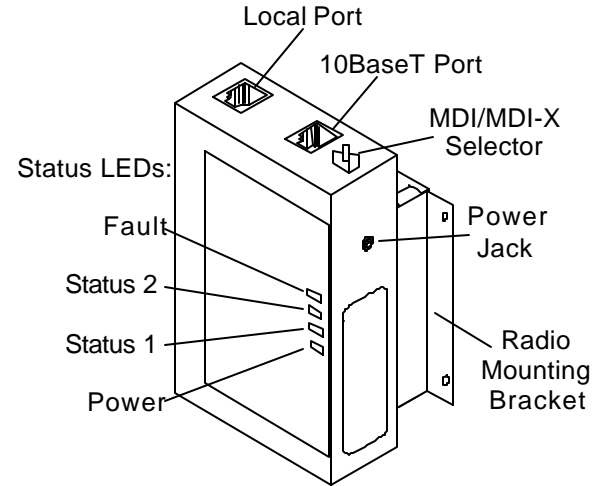

Figure 2: CPU (Campus BridgeLINK™ Processor Unit)

- The amber Fault LED illuminates for several seconds during the power-on diagnostic sequence. When the CPU is operating, this LED is normally extinguished.
- The green Status 1 LED illuminates when the CPU detects the presence of the distant CPU. When the CPU is operating, this LED normally illuminates when the near and far CPUs are active.
- The green Status 2 LED illuminates when the CPU detects the presence of data passing through the wireless link. During normal CPU operation, this LED flickers when near and far CPUs are active.

One end of the CPU features a button and two ports:

- MDI/MDI-X selector button
- 10BaseT port
- Local port

MDI/MDI-X Switch

The MDI/MDI-X selector button switches the jack's pin assignment of transmit and receive data wire pairs for the 10BaseT port.

Use MDI-X configuration when the remote end of the wires is connected to a network station. For example, use this setting when connecting the CPU to a 10BaseT Network Interface Card or to an MDI port with a 10BaseT concentrator.

Set the switch for MDI configuration when the remote end of the wire is connected to a 10BaseT concentrator or a hub.

10BaseT Port Jack

Next to the MDI/MDI-X selector button you will find the 10BaseT port. The 10BaseT port interfaces the CPU to its local area network. The 10BaseT port is RJ45-compatible, which allows an eight-wire connection to a network hub or other hard-wired external device.

10BaseT LED Indicators

On the upper left and right corners of the 10BaseT port are green LEDs which indicate transmit and receive status from the network.

When the CAR LED illuminates, this indicates that the Ethernet carrier is active.

When the ACT LED illuminates, this indicates Ethernet activity on the network. This LED flickers during normal operation.

Local Port Jack

Located on the opposite end from the selector button, on the same face of the CPU, is the local port jack. The local port is compatible with RJ11 connectors and allows connection to a local terminal. When you need a local terminal connection, use the local terminal to configure the CPU.

CRM Port

At the opposite end of the CPU, there is a female 15-pin D connector. The connector allows you to connect the CRM to the CPU, using the cable that is attached to the Radio Unit.

Mounting Bracket

The mounting bracket is specially shaped so that it allows the CRM to slide into the mounting bracket before securing the CPU to a flat surface.

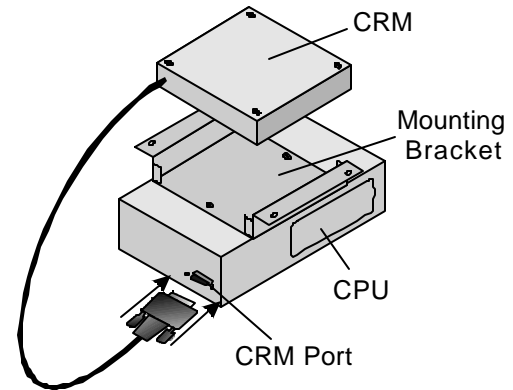

Figure 3: CRM (Companion Radio Module) Port

The Companion Radio Module (CRM)

The CRM interfaces the CPU with the directional antenna. The CRM is small, durable, and designed to insert easily into the mounting bracket that is attached to the CPU.

On one end of the CRM, there is a Type N connector and an LED indicator. The Type N connector attaches the CRM to the directional antenna.

The LED illuminates amber when the CRM is transmitting data. It illuminates green when the CRM is receiving data.

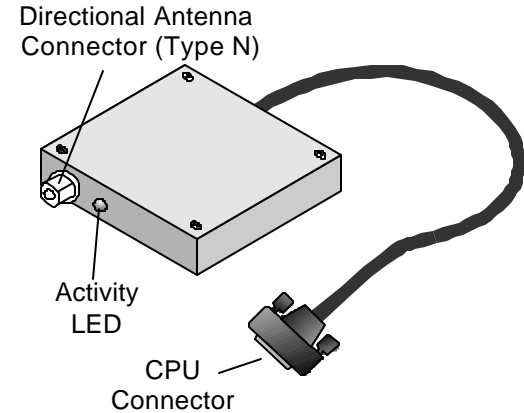

Figure 4: CRM (Companion Radio Module)

Power Transformer

The power transformer provides an easy connection to electrical outlets. One end of the transformer has a power cable with a connector that is compatible with the CPU's power jack. The other end plugs into an electrical outlet. RadioLAN recommends using a non-switched electrical outlet for connection to the CPU.

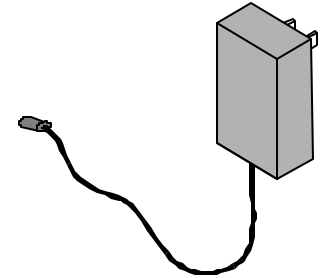

Figure 5: Power Transformer

The Directional Antenna

The directional antenna assembly includes the directional antenna and a mounting clamp. The directional antenna is a 18dbi-gain, small-profile directional antenna. It is 8.86 inches square, and mounted on a pivoting base.

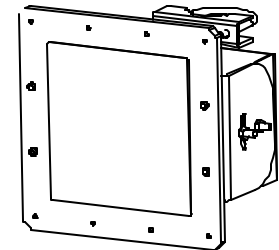

Figure 6: Directional Antenna

Antenna Cable

The antenna cable provided is a 15-foot, low-loss cable. It is made of fire retardant material, and is UV stabilized. Cold-shrink tubing is supplied to cover the antenna end connector after connection to the cable. See the installation instructions packaged with the shrink tubing for installation directions.

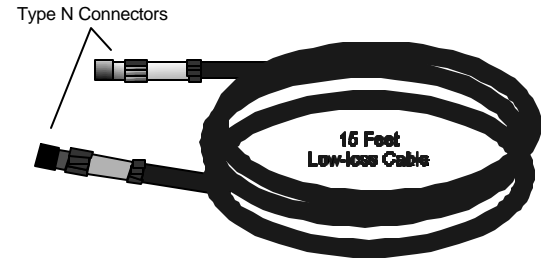

Figure 7: Low-Loss RF Cable

A Typical Campus BridgeLINK™ Application

Figure 8 shows a typical Campus BridgeLINK application in which two buildings, with local area networks in each, are located up to one mile away from one another. Notice that there are no solid obstructions between the two buildings and that each building antenna points toward the other.

Because the system uses radio frequency to establish the connection between the two buildings, it is important to avoid blocking the radio link with any objects, such as trees, buildings, walls, or items that are attached to the building walls, such as stairwells, fire escapes, or other antenna equipment.

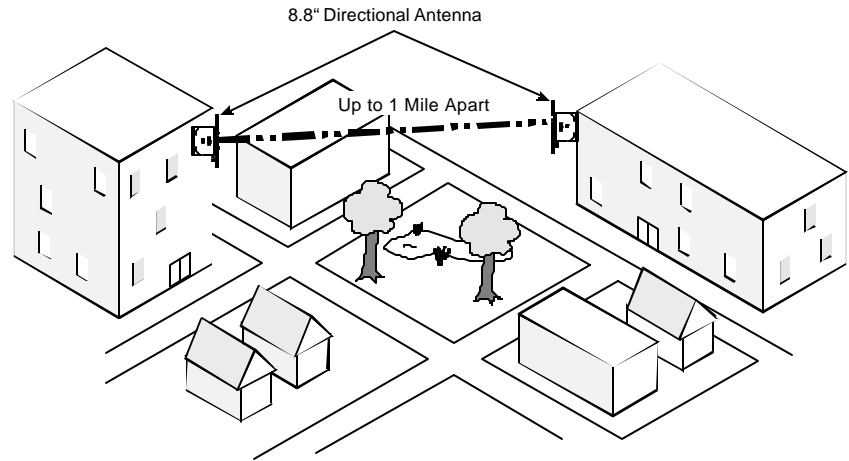

Figure 8: A Typical Campus BridgeLINK™ Application

Figure 9 illustrates the networks inside each building. Notice that the CPU is attached directly to a hub, which connects network nodes together.

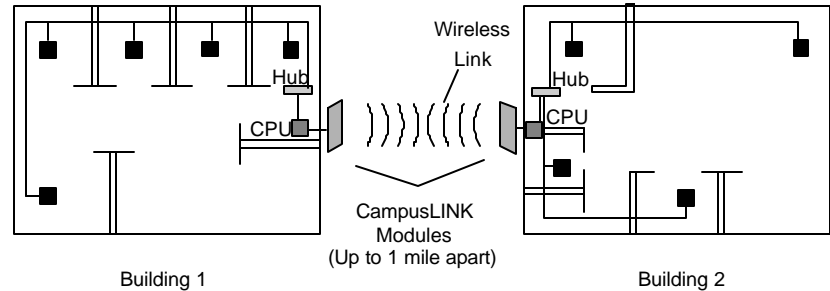

Figure 9: Linking Networks in Two Locations

Determining the Distance between Buildings

It is important to verify that you do not exceed the distance capabilities of Campus BridgeLINK. If you are unsure of the distance between the two points, you can use a measuring device, such as optical devices found in some binoculars, or a tape measure. You can also see the architect's site plan or contact a local surveying service for assistance.

Initial IP Address Setup

Before you can use the TCP/IP management services of a CPU, it must contain a valid network IP Address. There are three ways to assign an IP Address to the CPU:

- Connection between the CPU and a PC on the same local LAN segment
- A VT-100 terminal connection to the CPU Local Port

This section describes in detail each method for assigning the CPU an IP Address.

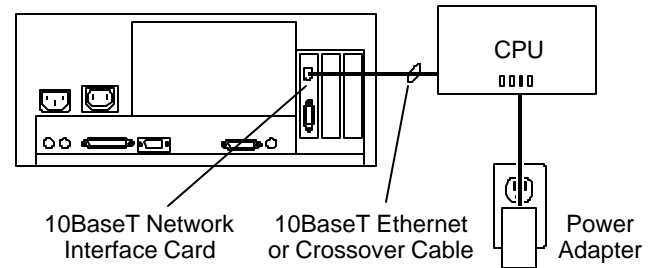

Figure 10: Quick Configuration

Temporarily Connect the CPU

To use the IP ASSIGN Utility, you must first obtain a PC with a 10BaseT Network Interface Card that has its own IP Address. The PC must not be running a DHCP Server while performing this procedure.

1. Determine the method that you are using to assign the IP Address:

Using a PC with a 10BaseT Network Interface Card: If you installed the IP ASSIGN Utility in a PC with a 10BaseT Network Interface Card, connect an RJ45, 10BaseT cable between the CPU and the jack on the PC's Network Interface Card.

Using the CPU Local Port: If you are using the local port, connect the serial port from a VT-100 terminal to the CPU local port.

2. Connect the Radio Unit to the CPU.
3. Connect the CPU's power adapter to the power jack on the CPU.
4. Plug the CPU's power adapter into a 115VAC electrical outlet.

The CPU's Power LED illuminates.

If you are using a PC with a network interface card, see *Using the IP ASSIGN Utility to Assign the CPU's IP Address* on page 14. If you are using the CPU local port, see *Managing the CPU Locally* on page 86.

Using the IP ASSIGN Utility to Assign the CPU's IP Address

RadioLAN provides the IP ASSIGN Utility diskette with your package. The utility allows you to assign an IP Address to the CPU quickly.

To install the IP ASSIGN Utility and assign an IP Address to the CPU, follow these steps from a PC connected to the CPU:

1. Insert the IP ASSIGN Utility diskette into drive A.
2. Using the Windows RUN command, type A: IP ASSIGN and click OK.

The utility starts and begins searching the local LAN segment for any CPUs that are not configured with an agent IP Address.

The utility returns a page listing of the Media Access Control (MAC) Addresses for all non-configured CPUs on the LAN segment.

3. Highlight the MAC Address for the CPU that you want to configure.
4. Enter the desired temporary IP Address for the CPU. Later, you can permanently set it using the IP PARAMETERS page.

The utility checks the IP Address to verify its validity. If the newly entered IP Address is valid, the utility assigns it to the CPU and prompts you to configure the CPU using your network browser.

5. Choose Yes to launch your default network browser, and press **Enter**.

The utility displays the login page for the CPU configuration program.

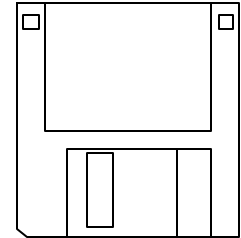

Figure 11:
Configuration
Disk

Installing the CPU

When installing a CPU you must mount it onto a wall or a ceiling. You must locate the CPU at a distance from the antenna that is no farther than the cable will allow. The cable length is a maximum of 15 feet; this means you must consider all bends in the cable when determining your distance.

You must also locate the CPU in an area from which it has access to local network cabling and electricity. Before selecting an electrical outlet for use in powering the CPU, verify that the electrical outlet is non-switched (for example, it is not attached to a wall switch). You should also consider placing the CPU in a location where it is out of reach of the general public.

FCC regulations require that this device be professionally installed by a person knowledgeable in electronics and trained in the correct installation of this device.

All interface cables must be shielded.

Tools You Will Need

To install the CPU, you will need the following tools: drill, drill bit, screwdriver, screws, pencil, measuring tape.

Locating the CPU

After verifying that the CPU is located near a power source and network cabling, and is within the 15-foot cable distance constraint of the antenna, you must install the CPU securely to the mounting surface (for example, a wall or ceiling).

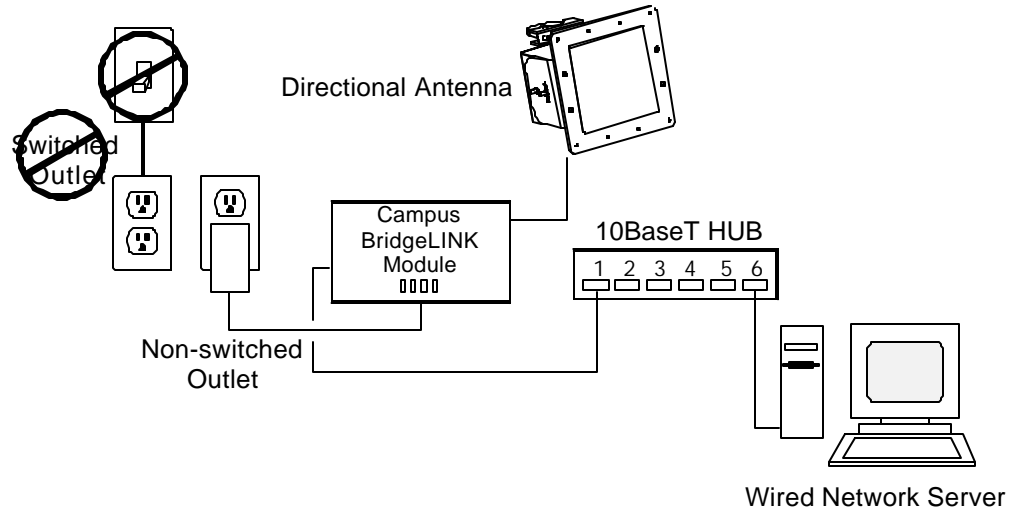

Figure 12: Locating the CPU Closely to Network, Power, and the Antenna

Mounting the CPU

When mounting the CPU, you must follow these steps.

Before mounting the CPU to the mounting surface, connect the connector at the end of the CRM's cable to the 15 pin D connector on the CPU (see Figure 13).

Route the antenna cable from the directional antenna to the CRM, and slip the cold-shrink tubing over the end of the cable before connecting the cable to the antenna.

Connect the cable to the CRM, using a clockwise rotation. Tighten the antenna connector so that it is snug but does not strip the threads of the connector on the CRM.

Complete the shrink tubing installation by following the instructions provided with the tubing.

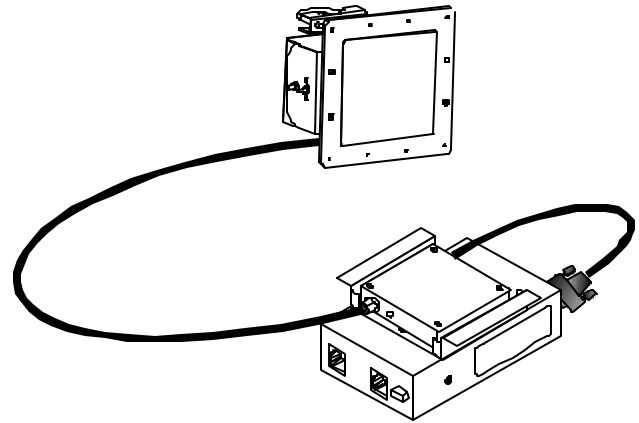

Figure 13: Connecting the Antenna Cable to the CRM

Orient the CRM so that its cable does not cross over the mounting brackets and then insert the CRM into the mounting bracket so that it is flush with the rim of the bracket (see Figure 14).

Orient the CPU on the mounting surface in the location where you would like it to be attached.

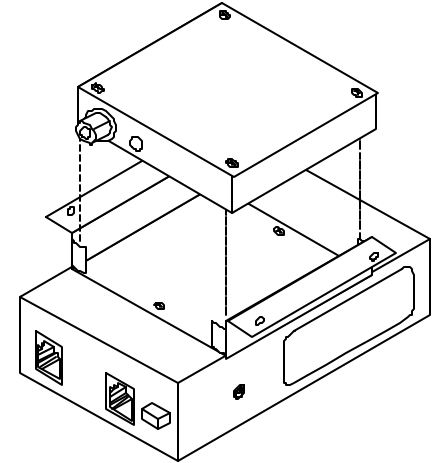

Figure 14: Inserting the CRM into the Bracket

Use a pencil to mark the brackets screw hole locations onto the surface upon which you will mount the CPU.

At the location's screw holes, install any necessary anchoring devices. This is especially recommended when installing the CPU onto a sheet-rock or gypsum surface.

Hold the CPU up to the mounting surface (see Figure 15), orienting the screw holes with the mounting anchors, then drive screws securely into the surface. Tighten down the screws.

Connecting the Network

When connecting the CPU to the hardware network hub or to a PC, you must use a RJ45-compatible, dual modular cable. The cable is an eight-wire, twisted-pair cable and must not exceed the distance limitations provided by the IEEE 802.3 standard. After routing the cable to the network, insert the modular connector into the port on the CPU.

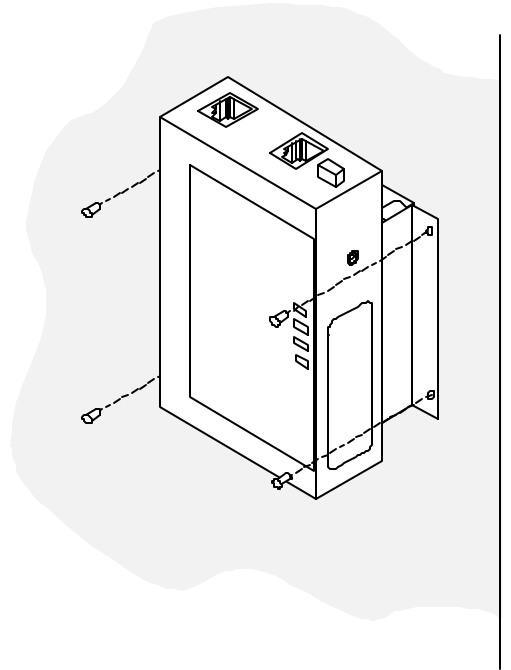

Figure 15: Marking Screw Locations

Grounding Considerations

RadioLAN recommends that you properly ground the directional antenna as described in mounting hardware installation instructions and required by your local ordinances.

RadioLAN recommends that you connect the antenna assembly to a ground rod driven a minimum of 10 feet into the soil. For proper grounding of the antenna and cable follow Section 810 of the National Electrical Code. Use UL-listed ground clamps and lugs.

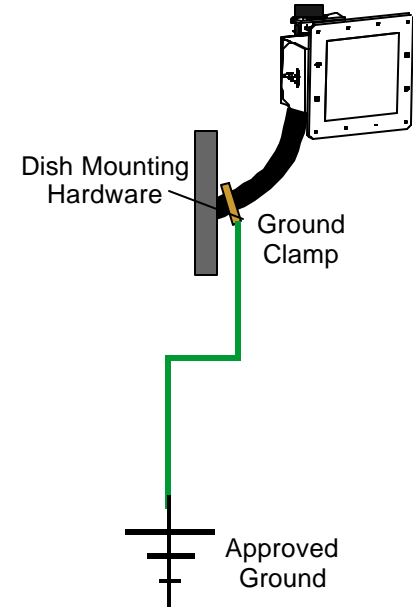

Figure 16: Acceptable Ground Source

Installing the Antenna

There are many methods for mounting the antenna onto a wall. The assembly includes a U-bolt that allows you to connect the directional antenna to a standard size mounting assembly that is used for other directional antenna applications. Directional antenna wall-mounting assemblies are available at your local computer store or retailer who sells directional antennas or satellite services. The directional antenna uses a U-bolt with a nut on each end. Slide the mounting clamp through the two eyeholes on the backside of the directional antenna, then secure the clamp to the mounting equipment that you chose.

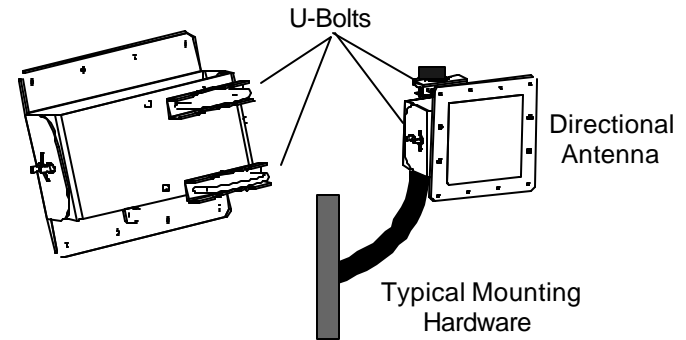

Figure 17: Attaching the Directional to a Typical Mount

A Brief Word About Safety

If you chose to mount the antenna high up on a wall, make sure that you use the appropriate type of ladder. Follow ladder safety tips provided by its manufacturer. RadioLAN recommends that you have a partner available to secure the ladder and to offer assistance while you are on the ladder. RadioLAN recommends that you not mount the unit during stormy weather, on windy days, or anywhere near electrical cables.

Choosing the Best Mounting Height

Make sure that you choose the appropriate mounting height for the directional antenna. You must consider the cable distance between the directional antenna and the CPU, and the level of accessibility for routing cable and mounting the CPU.

If the structure has an eave, RadioLAN recommends that you not place the antenna up so high into the eave that the roof blocks a line-of-sight view to the antenna on the distant Campus BridgeLINK™ building. Before securing the antenna to the wall, verify that you can see the distant directional antenna and that the line of site is clear of all obstructions.

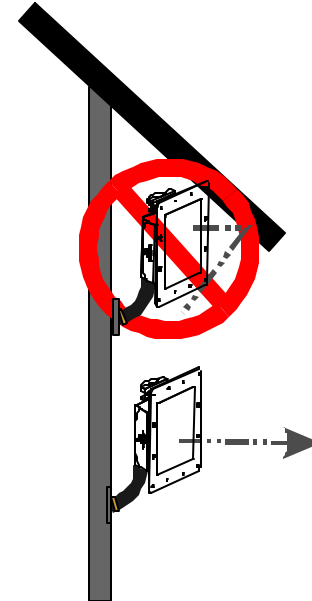

Figure 18: Minimum Height from Ground

Sighting Each Campus BridgeLINK™ Antenna

Once you have installed and grounded the mounting bracket assembly (provided by others), you can point the directional antenna toward the location of the distant antenna.

Tools You Will Need

To site the antenna properly, you will need to have a crescent wrench, a carpenter's square, a ladder, and a helper.

Adjusting the Antenna's Direction

To adjust the antenna's direction, you will:

1. Loosen the U-bolts to turn the antenna into the correct side-to-side direction (azimuth).
2. Loosen the nut on the tilt mount to adjust the antenna to the proper elevation.
3. Tighten all nuts and bolts to safeguard the antenna against direction changes during high winds.

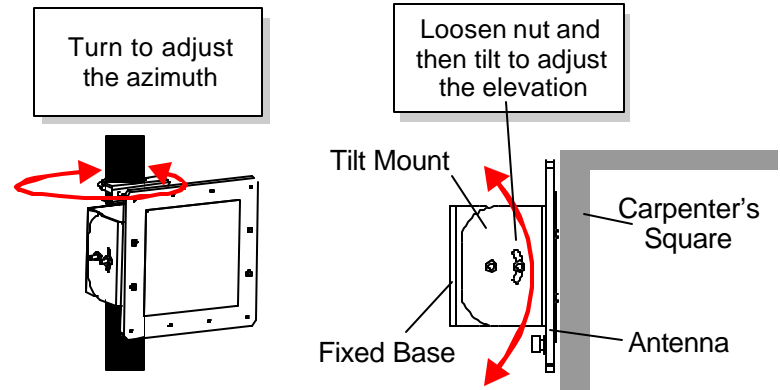

Figure 19: Aligning the Antenna

Sighting Procedure

Campus BridgeLINK™ uses a 19° angle of reception for each of its antennas. This means that, from the center of the directional antenna, you can angle away from your target for as much as 9.5° in any direction. This makes it very easy to site the two antennas and align them properly.

Sighting greater distances: If your application requires that the buildings are nearly one mile apart, it may be difficult to visually resolve the distant Campus BridgeLINK™ antenna. In these cases you may need a compass, GPS, local maps, or other direction calibration equipment.

Greater distances increase probability for line-of-site blockages: As the distance between buildings increases, there is a greater likelihood for objects appearing that block the line-of-site between Campus BridgeLINK™ sites. When planning applications with greater distances, avoid problems caused by new construction, or a large grove of trees between the two sites by placing the antenna higher. This decreases the likelihood for line-of-site blockages through time.

Eyeball the Direction

Using a carpenter's square (see Figure 19) align the square across the directional antenna's surface and adjust the antenna so that the carpenter's square points toward the distant Campus BridgeLINK™ antenna location.

After aligning the antenna, tighten the nuts on the mounting assembly so that it stays affixed in this direction and cannot be easily blown out of alignment by wind or heavy rain.

Next, connect the antenna cable to the back of the antenna. You can further align the two antennas, using the Campus BridgeLINK™ Manager. See *Aiming the Directional Antennas* on page 33 for more information.

Apply Power to the CPU

After verifying that the antenna cable is properly attached to the antenna and the CRM, and after making sure that the CRM is properly attached to the CPU, you can apply power to the CPU following these steps:

1. Connect the CPU to the power transformer.
2. Connect the power transformer to the electrical outlet.

If the CPU is properly powered, you should notice that the green Power LED illuminates.

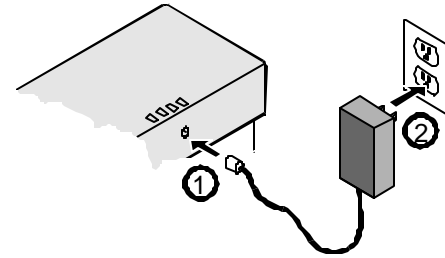

Figure 20: Power Connection Sequence

Adding Security to the Wireless Network

As an option, you can contact RadioLAN to enable the Data Encryption feature. This feature secures the wireless link by setting an encryption key that protects your sensitive data on the wireless link. When you enable Data Encryption, only CPUs that share the same encryption key can share data.

Local Management

The CPU includes a built-in serial port for connecting a VT-100 terminal or a modem. Using a terminal allows you serial access configuration and system performance pages. Connecting a modem to the serial port allows you to dial into the CPU from a remote location to log in and configure or view system performance.

Dual Remote Management: HTML and SNMP

The CPU contains an SNMP (Simple Network Management Protocol) agent. When a remote SNMP Manager interrogates the agent, the agent presents system configuration and statistical information by way of the MIB (Management Information Base). While connected to the agent through the network, the manager receives the MIB and can see wireless network performance information.

When you use your SNMP Manager, you can make changes, see current status, and review new network history. The CPU now supports SNMP management, using the standard MIB for selected functions. Contact RadioLAN for a copy of the CPU's MIB object functions.

The CPU's interface includes system security authentication passwords, so only remote users with the correct password can access and configure the CPU. The CPU offers up to three security access passwords, each configurable for read and/or write rights.

System Requirements

To successfully place a CPU into operation, you must meet the following requirements:

- The CPU must connect directly to a 10BaseT Network.
- The CPU must be located within one mile of another Campus BridgeLINK™ CPU.
- The network must use TCP/IP to communicate, using remote management.

Browser Requirements

To access the CPU by way of a 10BaseT Network, you must use a browser that is compatible with HTML, frames, and Java™ script language, such as Netscape™ 4.x or Microsoft Internet Explorer™ 4.x provides.

Using the Campus BridgeLINK™ Manager

The Campus BridgeLINK™ Manager allows you to interrogate and interact with the CPU from a remote location on the IP network, using a Web browser to communicate with the CPU. Your browser must support Java script and frames. After launching your browser, enter the IP Address for the CPU. If you just set up the CPU for the first time, you should have already assigned the CPU's IP Address using the IP ASSIGN Utility or with the VT-100 terminal.

This section discusses how to find the CPU on your network, how to log onto the CPU, and how to use the CPU Web Site.

The CPU Web Site

The Campus BridgeLINK™ Manager allows you to view pages which contain configuration information about the CPU. Using the Web Site, you can assign passwords, set up IP Addresses for the CPU and SNMP management stations, set address filters, and view system performance statistics.

When using the Campus BridgeLINK™ Manager to make changes, edit your choices on the site's pages, then accept all session changes by accessing the SYSTEM CONFIGURATION - CONFIGURATION CHANGES PAGE. This causes the CPU to store configuration changes. Changes take effect after you save the changes and reset the CPU (see *Saving or Rejecting Configuration Setting Changes* on page 77).

Browsing the Network for the CPU

To find the CPU on your network, follow these steps:

1. Open your Web browser
2. In the browser's address field, type the IP Address for the CPU, then press **Enter**.

The browser searches the network for the CPU. When it finds the CPU, the ENTER NETWORK PASSWORD page appears.

Logging onto Campus BridgeLINK™ Manager

The ENTER NETWORK PASSWORD page provides security to CPU configuration items. There are two fields on the page:

- User Name
- Password

If this is the first time that you log on: This screen appears only after User Names and passwords are stored in the CPU (see *Setting Up Security Features* on page 35 for more information). If no User Names and Passwords are stored in the CPU, the program bypasses the ENTER NETWORK PASSWORD screen and displays the main program screen

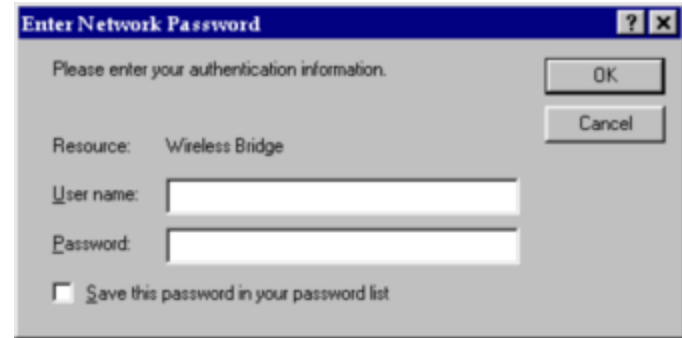

Figure 21: Logging On

Product ID

The Product ID field is a read-only field that reports the Product ID for the CPU.

Enter User Name

The Enter User Name field is an entry field where you enter your user name to gain access to the configuration and diagnostic pages. Only entries matching those programmed into the SYSTEM CONFIGURATION: ACCESS SECURITY page are allowed access to the program.

Enter Password

The Enter Password field allows you to enter your user password for access to configuration and diagnostic pages. Enter your password here and then press **Enter** to go to the next page.

If the user name and password match those stored in the ACCESS SECURITY page, you will be allowed to view and edit items on the page. If you make entries that do not match those stored in the program, you will remain on the ENTER NETWORK PASSWORD page.

Campus BridgeLINK™ Manager Site Layout

The Campus BridgeLINK™ Manager Site uses frames that allow you to size and view the pages according to your needs. The main menu is made up of the following items:

- Node Discovery--Checks the quality of the link.
- System Features--Enables enhanced CPU features.
- System Configuration--Configures the CPU for use with your 10BaseT Network and wireless link.
- System Statistics--Displays system performance.
- System Status--Displays the system's current status.
- Antenna Aiming--Fine tune your directional antenna.
- Reset--Resets the CPU.

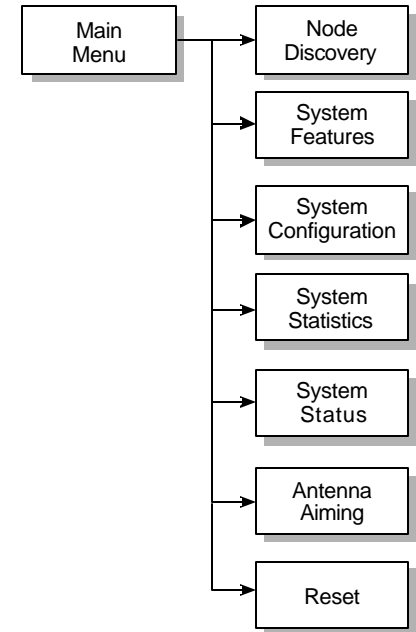

Figure 22: Campus BridgeLINK™ Manager Main Menu

Figure 23 shows the main screen. The left side of the page contains a menu that allows you to select the screen that you want to view or change.

Menu items that have a [+] next to them have submenu items that lead to specific pages. After selecting a submenu item, the right frame of the page changes to display program items and other information. You can size the frames by clicking on the divider line and dragging the line to the size that meets your needs.



Figure 23: Campus BridgeLINK™ Manager Main Page

Aiming the Directional Antennas

If you are installing the Campus BridgeLINK™ system, or if you want to improve the alignment of the two directional antennas, use the ANTENNA AIMING page to find the distant antenna's signal, and to improve signal quality. The page includes the following items:

- Explicit Address check box
- CPU Name drop-down list box
- Frame Size field
- Estimated Distance list
- Successful % field
- Best field
- Worst field
- Sound check box
- Start button
- Stop button
- Save Distance Parameter button



Figure 24: Antenna Aiming Page

Selecting the Distant CPU's Address

The ANTENNA AIMING page allows you to select the remote CPU's name or explicit address. If you place a check in the Explicit Address check box, the CPU Name list box displays the field to enter the MAC Address of the distant CPU. Clearing the Explicit Address check box displays the port name of the distant CPU. See *Port Name* on page 54 for information about setting the CPU's Port Name field.

Setting the Frame Size

Select the desired frame size that you want to use for testing purposes. Similar to a PING, adjusting the frame size can vary test results. Enter your selection in the Frame Size field.

Setting the Estimated Distance between Antennas

The Estimated Distance list allows you to choose the estimated distance between links. Click a value in the list to make your selection. After testing, you can save the entries on the page by clicking the Save Distance Parameter button.

Starting and Stopping the Test

You can begin and end the testing at any time. Click on the Start button to begin the test. Click on the Stop button to end the test.

Viewing or Hearing Status of the Link

Once you have started the test by clicking the Start button, you can view test results by viewing the Successful % field. You can also view the best and worst-case scenarios by looking at results that appear in Best and Worst fields. This page features audio status of the Successful % field when you place a check mark in the Sound check box.

Setting Up Security Features

The ACCESS SECURITY PAGE allows you to specify up to three user names and passwords, which allow entry into the configuration and diagnostic pages. To get to this page, select Access Security from the System Configuration menu.

User Logon Name Fields

The User Logon Name fields allow you to enter from 1 to 12 characters to specify a user name. You can use letters and numbers for this entry. This entry is case-sensitive, so be sure to note the user name exactly as you enter it here.

Make your entry, then press the **Tab** key to move to the User Logon Password field.

The User Password and Retype Password Fields

The User Logon Password and verification fields allow you to enter from 1 to 12 characters to specify the user password. You can use letters and numbers for this entry. This entry is a case-sensitive field, so be sure to note the user password exactly as you enter it here.



Figure 25: Access Security Page

Setting Up SNMP Capabilities

The CPU contains an SNMP agent, which processes information from the CPU MIB. The MIB (Management Information Base) contains system status information, which allows for remote queries for system status and control with SNMP management applications from remote locations on the network.

There are three basic information pages related to SNMP management:

- Administration Parameters
- IP Parameters
- SNMP Parameters

After configuring each of these pages, you will be able to access the CPU from any location on the 10BaseT Network if you have rights to do so.

Administration Parameters

The ADMINISTRATION PARAMETERS PAGE allows you to specify system identification information. This information is useful to allow remote network administrators to determine the:

- System Name
- System Contact
- System Location

These fields are described in the following sections. To access this page, select Administration Parameters from the System Configuration menu.

This page also includes three buttons:

- | | |
|-------------|------------------------------------------------------------------------------------------|
| Reload | Reloads entries saved at the last reset. |
| OK | Accepts entries. Choose this button when you have finished entering desired information. |
| Use Default | Enters default information into each field. |



Figure 26: Administration Parameters Page

System Name

The System Name field allows you to create an ID for the system agent. Enter from 1 to 15 letters or numbers for the system name.

System Contact

The System Contact field allows you to enter the name of the local administrator to contact for answers to questions and assistance with the system. Enter from 1 to 15 letters or numbers for the system contact. You may want to include a telephone number where you can reach the contact.

System Location

The System Location field allows you to enter the name of the geographic location of the system. Enter from 1 to 15 letters or numbers for the system location.

IP Parameters

IP Parameters allow you to set up information about the IP Address for the agent. The SYSTEM CONFIGURATION - IP PARAMETERS PAGE contains fields that allow you to set up IP Parameters. The following items are on the IP PARAMETERS PAGE:

- IP Address
- Subnet Mask
- Default Gateway IP Address
- DHCP Operation Modes
- DHCP Server IP Address

In addition to the fields and radio buttons on this page, there are three buttons at the bottom of the page:

- | | |
|-------------|------------------------------------------------------------------------------------------|
| Reload | Reverts fields to previous entries saved at the last reset. |
| OK | Accepts entries. Choose this button when you have finished entering desired information. |
| Use Default | Enters default information into each field. |



Figure 27: IP Parameters Page

IP Address

The IP Address field allows you to designate the IP Address for the agent. The IP Address identifies the agent on a TCP/IP Network.

The format of an IP Address is a 32-bit numeric address written as four numbers separated by periods. For example, 223.142.15.200 could be an IP Address. The first segment can range from 0 to 223; each other segment ranges from 0 to 255.

Within an isolated network, you can assign IP Addresses at random as long as each one is unique. If you are connecting the CPU directly to the Internet, standards require using a registered IP Address to avoid duplicates.

Subnet Mask

The Subnet Mask field determines the subnet and IP Address for the agent. Typically, an IP Address contains the network address and the host address.

If the network is divided into subnets, a part of the host address will be reserved to identify the particular subnet.

Default Gateway IP Address

The gateway is a combination of hardware and software that links two different types of networks. Gateways between networks, for example, allow users on different e-mail systems to exchange messages.

The gateway IP Address might identify a router that controls the flow of data packets to the node (computer, printer, etc.).

Type in the gateway IP Address using four numbers, each separated by a period. The first segment can range from 0 to 223, each other segment ranges from 0 to 255. The address looks similar to the following:

221.040.123.243

DHCP Support

Short for **D**ynamic **H**ost **C**onfiguration **P**rotocol, this protocol assigns dynamic IP Addresses to devices on a network. Dynamic addressing allows a device to have a different IP Address each time it connects to the network. In some systems, the device's IP Address can change even while it is still connected.

Dynamic addressing makes network administration easier because the software tracks issued IP Addresses rather than requiring an administrator to perform this task.

Disabled

The Disabled radio button disables DHCP support.

Acquire System IP Only

Select this radio button to cause the CPU to search for and acquire the temporary IP Address assigned by the DHCP Server.

Acquire IP and Download System Software

If your DHCP Server is equipped for System Software Downloads, you can acquire a temporary IP address and update system software with the function as an alternative to FTP and TFTP services discussed in *Upgrading System Software* on page 74. The downloaded software is only in use until the next reset. The CPU does not permanently save the software.

Acquire IP, Download System Software and Save it

If your DHCP Server is equipped for System Software Downloads, you can acquire a temporary IP address and update system software with the function as an alternative to FTP and TFTP services discussed in *Upgrading System Software* on page 74. This selection automatically saves system software when complete.

DHCP Server IP Address

If you selected anything other than the Disabled radio button, type in the DHCP Server IP Address in this field. If you set this entry to 0.0.0.0, any DHCP server will assign an IP address.

SNMP Parameters

The SYSTEM CONFIGURATION -SNMP PARAMETERS PAGE contains fields that specify the SNMP management and notification parameters. The local agent can communicate with up to five remote managers. You can edit SNMP Managing Hosts by clicking the Edit button. There are three messages that the CPU sends to Trap addresses:

- Cold Start** The CPU sends this message when it powers on.

- Warm Start** The CPU sends this message when software resets the CPU.

- User Authentication** The CPU sends this message if you placed a check mark in the Enabled Authentication Trap check box, and if a user had been denied access to the CPU Web Site three times.



Figure 28: SNMP Parameters Page

The following items are found on this page:

- Read Community field
- Write Community field
- Enable Authentication Trap check box

Read Community

The Read Community field contains up to 31 characters. You can use any character to create a string. Remote managers use this string as a password to enable read rights for objects reported by the local agent.

Write Community

The Write Community field contains up to 31 characters. You can use any character to create a string. Remote managers use this string as a password to enable the ability to make changes on system objects reported by the local agent.

Enable Authentication Trap

The Authentication Trap sends a message to selected Host Addresses when a remote manager attempts to access the local agent. The Enabled check box provides two options:

- | | |
|-----------|--------------------------------------------------------------------------------------------------------------------------------------------------------------------|
| Checked | This enables Authentication Trap messages to broadcast to selected Host Addresses. See <i>Directing Traps to Manager Stations</i> on page 46 for more information. |
| Unchecked | This disables messages to selected Host Addresses when remote managers attempt to connect with the local agent. |

Configuring SNMP Managers for the CPU

The SYSTEM CONFIGURATION – CONFIGURE SNMP HOST PAGE offers five IP Address fields, allowing you to designate the IP Addresses for up to five SNMP Manager stations. This identifies the station on a TCP/IP Network.

The format of an IP Address is a 32-bit numeric address written as four numbers separated by periods. For example, 221.142.15.200 could be an IP Address. The first segment can range from 0 to 223, each other segment ranges from 0 to 255.

Within an isolated network, you can assign IP Addresses at random as long as each one is unique. If you are connecting the CPU directly to the Internet, standards require using a registered IP Address to avoid duplicates.



Figure 29: Configure SNMP Host Page

Setting Access Rights for SNMP Managers

The Access Right column contains radio buttons that allow you to select the following options:

- Get only** Allows the SNMP Manager Station at the selected IP Address to retrieve information from the CPU. When this is selected, the CPU will not allow the Manager to make changes.
- Get and Set** Allows the SNMP Manager Station at the selected IP Address to retrieve information from, and make changes to the CPU's configuration program.

Directing Traps to Manager Stations

The Receive Trap column contains radio buttons that allow you to select the following options:

- Yes** Instructs the CPU to send Trap messages to the selected Manager Station.
- No** Prohibits the selected Manager Station from receiving Trap messages from the CPU.

Directing the System Log to Manager Stations

The Receive SysLog column contains radio buttons that allow you to select the following options:

- Yes** Instructs the CPU to send system log messages to the selected Manager Station.
- No** Prohibits the selected Manager Station from receiving system log messages from the CPU.

Setting the CPU's Mode of Operation

The SYSTEM CONFIGURATION – SYSTEM OPERATION MODE PAGE allows you to set up the method that you will use for operating the CPU. This screen displays software options that are currently enabled. If you are using CPU version 2.0 or higher, the screen allows you to use only one option:

- Point-to-Point Mode

Point-to-Point Mode

Point-to-Point Mode sets the CPU into a mode of operation suitable for Campus BridgeLINK™ applications.



Figure 30: System Operation Mode Page

Securing the CPU with Data Encryption

If you have enabled encryption, the System CONFIGURATION – DATA ENCRYPTION PAGE allows you to secure wireless data by using Data Encryption. This page offers two selections:

- Enable check box
- Encryption Key field

Data Encryption Enabled Check Box

This selection enables or disables Data Encryption on CPU data packets.

Checked Enables Data Encryption. The two CPUs must share the same encryption key to exchange data.

Clear Disables Data Encryption. All CPUs with the same Subnet ID can exchange data.

Encryption Key and Retype Encryption Key Fields

These items set the encryption key for the CPU.

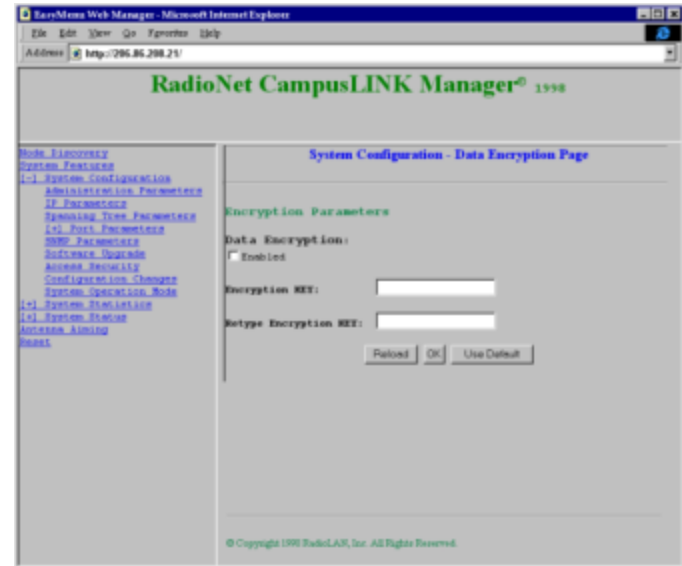

Figure 31: Data Encryption Page

Bridging the Link and 10BaseT Networks

Because the CPU is a bridging device that connects a 10BaseT Network to a wireless link, the CPU must learn about the network. The CPU dynamically learns MAC Addresses as distant network nodes.

The CPU passes data packets that are addressed to far-end network users found in its current service table. If a data packet is addressed to a distant network node that is in the current service table, the CPU accepts the data packet, then forwards that packet to the distant CPU. When a distant node is not in the current service table, the CPU does not pass data packets for that node through to the wireless link.

This method of filtering keeps the wireless link free from unnecessary messages, so that the wireless link provides the maximum performance and speed possible.

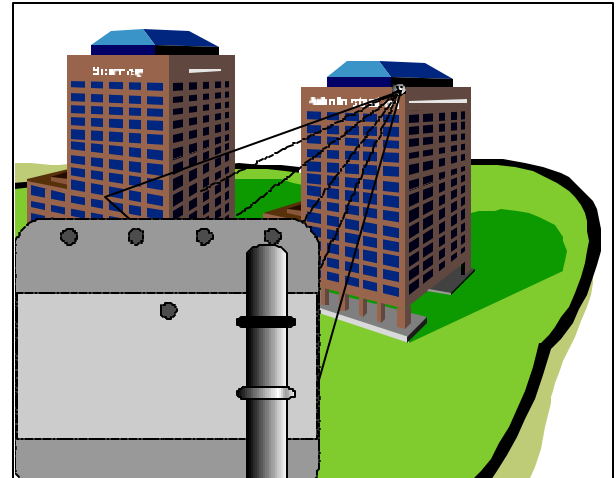

There are two pages that allow the CPU to learn about the 10BaseT Network. Select the Port Parameters menu item to access these pages:

- 10BaseT Parameters page
- Radio Port Parameters page

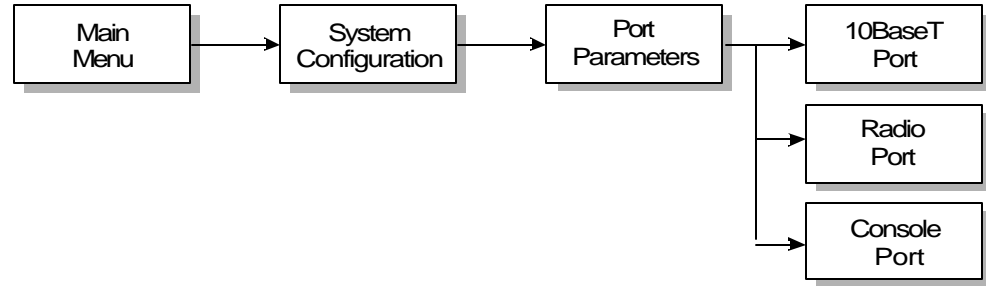

Figure 32: Getting to the Port Parameters Menu

Each page contains information about filters used by the CPU to route data packets in and out of each network. In addition, the CONSOLE PORT PAGE sets the baud rate for the local port.

10BaseT Port Parameters

The 10BASET PORT PARAMETERS PAGE displays the 10BaseT port's name, allows you to enable or disable the port and network filters, and allows you to examine the MAC Address filter. Filters that you can enable or disable are as follows:

- MAC Address Filter
- IP Filter
- IPX Filter
- NetBEUI Filter
- NetBIOS Filter

To get to this page, select Port Parameters from the System Configuration menu.

MAC Address Filter

The MAC Address Filter check box allows you to enable or disable the CPU's internal MAC Address filter. The MAC Address filter is a database that stores MAC Addresses received by the CPU while communicating with the 10BaseT and wireless link. Once information is stored in the database, you can allow or disallow packet flow to or from remote addresses in the database.



Figure 33: 10BaseT Port Parameters Page

- Checked Placing a check mark in the check box enables MAC Address filtering. This filtering is essential for keeping wireless link traffic to a minimum, allowing only necessary data packets to transmit over the wireless link.
- Unchecked Clearing the check mark from the check box disables MAC Address filtering. This allows all network traffic to flow from the 10BaseT Network into the wireless link.

Edit Button

The Edit button displays the MAC Address database, allowing you to enable or disable communication with specific devices on the 10BaseT Network. See *Managing Packet Flow Through the CPU* on page 57 for more information.

Block IP Packets

The Block IP Packets check box allows you to enable or disable communication with networks using IP addressing.

- Unchecked Clearing a check mark from the check box enables IP packet forwarding.
- Checked Placing a check mark in the check box blocks IP packet forwarding.

Block IPX Packets

The Block IPX Packets check box allows you to enable or disable communication with Novell IPX protocol networks.

Unchecked Clearing a check mark from the check box enables IPX packet forwarding.

Checked Placing a check mark in the check box blocks IPX packet forwarding.

Block NetBEUI Packets

The Block NetBEUI Packets check box allows you to connect to Windows NT, Windows for Workgroups, or LAN Manager servers.

Unchecked Clearing a check mark from the check box enables NetBEUI packet forwarding.

Checked Placing a check mark in the check box blocks NetBEUI packet forwarding.

Block NetBIOS Packets

The Block NetBIOS Packets check box allows you to connect to networks that use the Network **B**asic **I**nput **O**utput **S**ystem.

Unchecked Clearing a check mark from the check box enables NetBIOS packet forwarding.

Checked Placing a check mark in the check box blocks NetBIOS packet forwarding.

Radio Port Parameters

The RADIO PORT PARAMETERS PAGE displays the radio port's (wireless link) name, allows you to enable or disable the link and network filters, and allows you to examine the MAC Address filter. You can edit the MAC Address filters by clicking the Edit button. See *10BaseT Port Parameters* on page 51 for information about the following filters:

- MAC Address Filter
- IP Filter
- IPX Filter
- NetBEUI Filter
- NetBIOS Filter

To get to this page, select Port Parameters from the System Configuration menu.



Figure 34: Radio Port Parameters Page

Port Name

The Port Name text box allows you to enter up to 12 characters that identify the name of the CPU. This appears as the CPU's address on the ANTENNA AIMING page (see *Selecting the Distant CPU's Address* on page 34 for more information).

Subnet ID

The Subnet ID text box allows you to enter the wireless network name. Both CPUs use the same Subnet ID designation. You can use up to four characters for this entry.

Setting the Baud Rate for the Local Port

The CPU allows you to connect and manage with a local terminal. To get to this page, select **Port Parameters** from the System Configuration menu, then select **Console Port**. The CONSOLE PARAMETERS PAGE allows you to set the baud rate for the terminal. Select from the following available baud rates:

- 9600 baud
- 19200 baud
- 38400 baud
- 57600 baud

After making your selection, click the OK button to keep your selection.

Set the VT100 terminal software for the following:

- Baud Rate (selected here)
- 8 bit word
- 1 stop bit
- No flow control



Figure 35: Console Parameters Page

Managing Packet Flow Through the CPU

The CPU can selectively allow or disallow traffic to or from the 10BaseT Network and the wireless link. Proper packet flow management improves the speed of the wireless link by eliminating unwanted network traffic.

The CPU is set for optimum performance by default. Only advanced users with special circumstances should use the entries on MAC Filter screens. Figure 36 shows the 10BASET PORT MAC FILTER – EDIT PAGE. The CPU contains and manages two identical filtering databases:

- 10BaseT Port MAC Filter List
- Radio Port MAC Filter List

Each of these databases allows you to add up to 32 MAC Addresses and to allow or disallow the receipt or transmission of data packets to specified MAC Addresses.



Figure 36: MAC Address Table

The databases contain the following columns:

- Item
- MAC Address
- Mask Bytes
- Source/Dest.
- Accept/Reject

Item

The Item column shows the order in which the CPU stored the database entry.

MAC Address

The MAC Address column displays the MAC Address (in six, two-character octets) for the remote network node. Enter the MAC Address of the device that you want to enter into the database.

Although you can use 00 as a specific value for an octet, you can also use 00 when creating a “wildcard” octet. Using wildcards allows you to specify a range of addresses, as opposed to just a single address.

For example, the first three octets of the MAC Address for all RadioLAN products is 00 A0 D4. If you want to allow all RadioLAN products access to the CPU, set the MAC Address field to 00 A0 D4 00 00 00, and the Mask Bytes field to ff ff ff 00 00 00. The wildcard is a result of a relationship between the MAC Address and the Mask Bytes field.

Mask Bytes

As an alternative to placing wildcards (00) in the MAC Address field, the Mask Bytes column allows you to select which octets in the MAC Address field will be read by the CPU (see Figure 37).

Entering ff into a mask bytes octet instructs the CPU to allow only MAC octets with a value matching the same location in the MAC Address field to pass. The CPU rejects any other entry in the octet position.

Entering a 00 into a mask bytes octet instructs the CPU to “mask” the octet. When the octet is masked, the CPU allows any entry to pass.

Entering an ff into a mask bytes octet, and a 00 in the same octet position of the MAC Address instructs the CPU to allow an entry matching only 00 to pass.

Source/Dest.

The Source/Dest. column allows you to specify whether the action upon packets will occur if that node is sending or receiving packets.

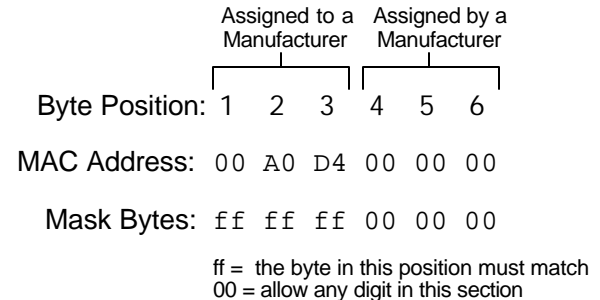

Figure 37: Working with Mask Bytes

Accept/Reject

The **Accept/Reject** column permits you to allow or disallow transmission of the packet, depending upon the entry in the **Source/Dest.** column.

For example, if **Source** is enabled in the **Source/Dest.** column, and the **Reject** radio button is enabled in the **Accept/Reject** column, the CPU will not allow a message broadcast from that MAC Address to pass through. If **Destination** is enabled in the **Source/Dest.** column, and the **Reject** radio button is enabled in the **Accept** column, the CPU will not allow the message intended for that MAC Address to pass through.

Alternatively, if **Source** is enabled in the **Source/Dest.** column, and the **Accept** radio button is enabled in the **Accept/Reject** column, the CPU allows the message from that MAC Address to pass through. If **Destination** is enabled in the **Source/Dest.** column, and the **Accept** radio button is enabled in the **Accept/Reject** column, the CPU allows the message from that MAC Address to pass through.

Adding MAC Filters

To add up to 32 MAC filters, select the first available (blank) Item:

1. Fill in the **MAC Address** and **subnet Mask Bytes** fields.
2. In the **Source/Dest.** column, select whether the filter will be invoked when the address is sending a packet or when it is receiving a packet:

Choose **Source** if you want to filter messages that are broadcast from the MAC Address.

Choose Destination if you want to filter messages that are broadcast from other nodes and intended for receipt by the MAC Address.

3. In the Accept/Reject column, you can allow or disallow the passage of the packet through the CPU based upon the broadcast type (source or destination) in the Source/Dest. column:

Choose Accept to allow the passage of packets to/from the MAC Address.

Choose Reject to disallow the passage of packets to/from the MAC Address.

After adding all desired MAC Addresses, click the OK button to exit the EDIT page.

Modifying MAC Filters

To modify a MAC filter, select the desired MAC Address. Make changes to the address fields and selections in the Source/Dest. and Accept/Reject columns.

After making changes, click the OK button to leave the EDIT page.

Deleting MAC Filters

To delete a MAC filter, select the address of the undesired MAC and mask address and type 00.00.00.00.00.00.

After deleting all undesirable MAC Addresses, click the OK button to exit the EDIT page.

Spanning Tree Parameters

When you connect two or more networks to increase the number of users, or enhance the ability for users of two (or more) networks to communicate with one another, you can control the routing of data to maximize the efficiency of the traffic between the networks.

Bridging characteristics allow you to route necessary messages between two networks and to eliminate unnecessary traffic to other networks when messages are only intended for use within the local network.

Furthermore, you can set up redundant paths for bridging, which reduces the potential for data path losses due to bridging network outages. You can establish a path redundancy for bridging networks and redundancy for ports on the same bridging network.

Path redundancy creates a loop by means of which data packets can potentially travel indefinitely if the bridge root network were unable to dynamically “prune” pathways between each network. The SPANNING TREE PARAMETERS PAGE allows you to set configuration items that allow the establishment of the root, redundancy of root networks, redundancy of root network ports to other networks, and dynamic pruning between network loops.

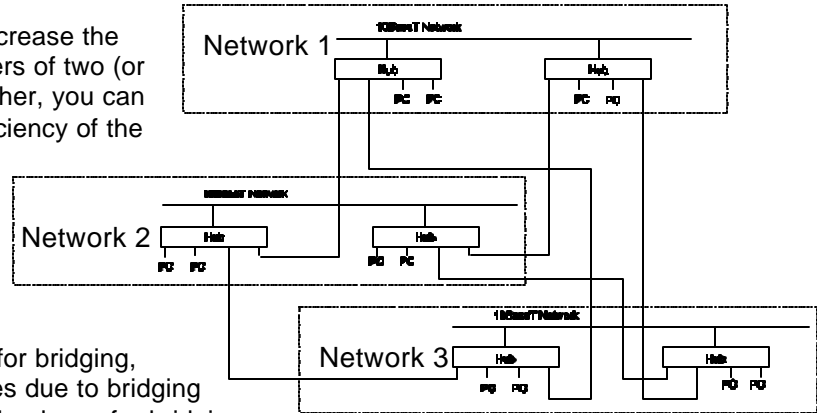

Figure 38: Bridging Networks

The SYSTEM CONFIGURATION - SPANNING TREE PARAMETERS PAGE allows you to set up bridging characteristics for the CPU that conform to Spanning Tree 802.1D protocol. The page displays the following items:

- Bridge Priority
- Hello Time (1–10)
- Forward Delay Time (4–3)
- Max. Age Time (6–40)
- Port Priority (0–255)
- Port Path Cost (1–65,535)

Bridge Priority (0–65,535)

Each bridge has a unique bridge identifier. Priority is a part of that identifier; it determines the topology. Smaller priority entries increase the probability of the network being selected as the root or primary bridge between other networks.



Figure 39: Spanning Tree Parameters Page

Hello Time (1–10)

Each time a network sends a frame, and no root bridge is present, the network sends a message that notifies other networks of its request to be the root bridge. If no other network responds to this “Hello” message, the network establishes itself as the root bridge between other connected networks.

When a network is established as being the root bridge, it sends the “Hello” message at the interval that you select in the Hello Time field.

Enter a value between 1 and 10 seconds for the “Hello” message interval.

Forward Delay Time (4–30)

When a root bridge has redundant ports, it is necessary to set the secondary redundant port to forward information only when the primary port has failed.

If the primary port operates normally, the bridge places the redundant port into a non-forwarding state, disallowing communication of messages that were transmitted on the operating primary port. When the primary port fails, the bridge places the redundant port into a forwarding state, which allows data packets to transmit to extended networks where the message is intended.

Only the active root bridge uses this value. Any bridge not acting as the root bridge uses a dynamic value for Forward Delay set by the root bridge.

Enter the number of seconds (between 4 and 30) that the bridge will wait for the primary port to pass a frame before switching the secondary port into the forwarding state, so that the secondary port can route data when the primary port fails to do so.

Max. Age Time (6–40)

The bridge maintains a routing database, containing unique source addresses of frames that the bridge receives from each network to which it is connected. The database relates a station's source address to a port on the bridge, and the bridge uses the database to choose which port it will use to transmit frames with a destination address matching the entry in the database.

The bridge compares each new frame's source address to entries within its internal routing database. If the bridge does not find a new frame's source address in the routing database, it adds the new frame's source address to the database.

The **Max. Age Time** field sets the amount of time in seconds that the bridge stores any source address. When the bridge stores a frame's source address, the address remains in the routing database for the length of time specified in **Max. Age Time**. If the bridge receives a new frame, and finds the frame's source address in the database, the bridge automatically resets the **Max. Age Time**, restarting the count. If the aging timer for an entry in the database expires before the bridge receives another frame with the same source address, the bridge removes the source address from its internal routing database. This prevents the database from storing information about inactive network stations.

Port Priority (0–255)

Bridges associate ports with physical devices, such as a router jack. A bridge can associate one or more ports with a physical interface. Each port is associated with a port priority, which contributes the topology of the network. The lower the number in this field, the higher the chance to become the designated port.

Port Path Cost (1–65,535)

Each port is associated with a port cost, which contributes the topology of the network. The lower the number in this field, the higher chance to become the designated port.

Interrogating the System for Performance Information

Performance is a combination of speed and accuracy. When the CPU transmits at higher rates, and retransmits packets fewer times, it has a higher rate of performance. Most users discover performance issues when sending large files from one CPU to the other.

Although multiple users can send information across the link at the same time, lower shared network resources can cause slower file transfer time. While data packets are being transferred, available link resources shared by all users decrease, so when the CPU finishes the job faster, increased shared link resources are made available for other packet transfers, making file transfer faster.

It is important to query the CPU for performance information occasionally. This allows you to determine when performance issues arise over time and indicates where you can make changes to improve performance.

One change might require the adjustment of a directional antenna to improve signal strength. Another adjustment might be filtering unnecessary packets to disallow passage into the wireless link. This type of fine-tuning is intuitive and one can determine actions, based upon statistics found in the following pages.

Checking 10BaseT Port Statistics

The SYSTEM STATISTICS - 10BASET PORT STATISTICS PAGE reports the CPU's ability to communicate with 10BaseT Network stations. The information on this page is automatically updated every ten seconds. This section describes the 10BASET PORT STATISTICS PAGE.

This page also contains a Clear Counters button. Clicking this button resets all counters on this page to zero.

The following sections describe the fields on this page.



Figure 40: 10BaseT Port Statistics Page

Total Packets Transmitted

Total Packets Transmitted counts and stores the total number of packets that the CPU sends to 10BaseT stations on the network. This number represents all transmitted packets.

Total Packets Received

Total Packets Received counts and stores the total number of packets that the remote 10BaseT stations send to the CPU. This number represents all received packets.

Total Error Packets

This field displays the total number of Ethernet errors accumulated.

CRC Error Packets

This field displays the total number of frames that reported a bad cyclical redundancy check.

Collision Error Packets

This field displays the number of packets that failed due to a collision—two stations attempting to access a media at the same time.

Overrun Packets

This field totals the number of frames that exceeded Ethernet maximum size specifications.

Runt Packets

This field totals the number of frames that were smaller than Ethernet minimum size specifications.

Packet Transmission

The Packet Transmission section stores information about packets that are sent from the CPU to the distant CPU.

Total Packets Transmitted

The Total Packets Transmitted field counts and stores the total number of packets that the CPU sends to the distant CPU across the wireless link. This number represents all transmitted packets.

Average Transmit Rate (Packets/Sec.)

Sometimes packets are transmitted more rapidly than at other times. The maximum transmit rate for 64-bit frames is approximately 14,600fps (frames per second). The Average Transmit Rate field indicates the average number of packets sent each second. Typical networks range from 100 to 5000 frames transmitted each second, and will vary with time. If you observe the rate consistently higher than 10,000 fps, you may have broadcast storms on your 10BaseT Network segment. These broadcast storms can be caused, for example, by a defective Network Interface Card or too many IPX Network stations sending broadcasts on the same network segment at the same time.

Total Retransmission

When the distant CPU does not acknowledge the receipt of a packet sent by the local CPU, the local CPU resends the packet a number of times until the distant station acknowledges receipt of the packet. The Total Retransmission field counts and stores the number of retransmissions, based upon the total number of packets transmitted.

A higher number in this field may indicate the need to correct the alignment of a CPU's directional antenna. You may also need to remove objects that block the line-of-site of the two directional antennas to improve signal quality.

Packet Reception

The Packet Reception section indicates the CPU's ability to receive packets from the distant CPU.

Total Packets Received

The Total Packets Received field counts and stores the total number of packets that the remote CPU sends to the local CPU. This number represents all received packets.

Average Receive Rate (Packets/Sec.)

Sometimes packets are received more rapidly than at other times. The Average Receive Rate field indicates the numbers of average packets received each second. You should see approximately 100 – 5000 pps (packets per second) under normal conditions.

Upgrading System Software

The CPU contains a default operating system, a running operating system, and a file containing configuration items. When you perform a software upgrade, the downloaded file is placed in temporary storage. If you are not using a DHCP server to update your software (see *IP Parameters* on page 39) you can use methods described in this section.

You can upgrade system software three ways:

- Using a local file on your PC (see Figure 42).
- Using a TFTP server (see Figure 43 on page 75).
- Using XMODEM through the CPU local port.



Figure 42: Software Upgrade (from file) Page

The SYSTEM CONFIGURATION – SOFTWARE UPGRADE

PAGE allows you to download a new configuration to the CPU. On this page, type in the name of the file that you want to download, then type in the TFTP Server IP Addresses. Select the Download button to download the file.

This page contains the following objects:

- Upgrade from file radio button
- Upgrade from TFTP server radio button
- System Software Filename field
- TFTP Server IP Address field
- Download button

Upgrade from File

Selecting this radio button allows you to select a file on your local hard drive. When you choose this radio button, the File to Upload field appears, allowing you to enter the name of the file to upload.

System Server Filename

This field allows you to enter the file name of the operating system file that you want to download. If you do not know where the file is located, click the Browse button to display a directory hierarchy.



Figure 43: Software Upgrade (from TFTP) page

TFTP Server IP Address

If you selected the Upgrade from TFTP Server radio button, the TFTP Server IP Address field appears. Enter the IP Address for the server where you will obtain the upgrade file.

Download Button

Upload causes the CPU to retrieve the specified software file from the specified location. The downloaded file is written into system memory as the CPU receives it. As the CPU reboots after downloading, the new operating system runs immediately.

Saving or Rejecting Configuration Setting Changes

The Configuration Changes menu item displays the SYSTEM CONFIGURATION – CONFIGURATION CHANGES PAGE. This page allows you to save your changes, or to reject changes you have made to allow the CPU to continue operating as before you accessed the CPU Web Site.

This page contains the following objects:

- **Save All Changes and Reset** radio button
- **Reload Last Saved Configuration** radio button
- **Reset Configuration To Factory Default** radio button



Figure 44: Configuration Changes Page

After making your choice, click the **OK** button to cause the CPU to act.

Save All Changes and Reset

This radio button causes all changes that you have made during this session to overwrite existing program entries. The CPU automatically resets and uses new configuration settings.

Reload Last Saved Configuration

This radio button causes all changes that you have made to revert back to their previous settings.

Reset Configuration to Factory Default

This radio button causes the CPU to change all configuration items to their factory default settings. These settings become permanent when saved.

Resetting the CPU

Any time you make configuration changes, or download a new version of the CPU's operating system, you must reset the CPU. One method of resetting the CPU is to remove power from the unit for approximately five seconds. Another method for resetting the CPU is found on the RESET PAGE.

To access the RESET PAGE, select the Reset menu item.

Click the OK button to reset the CPU.

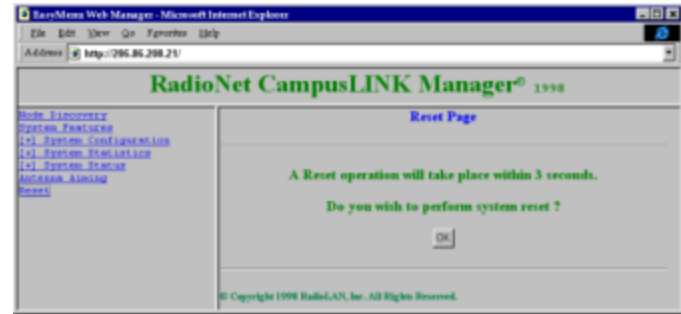

Figure 45: Reset Page

Recording Important System Information

Having system information on hand is essential to proper system management. The Campus BridgeLINK™ Manager makes it easy to keep information on hand, recording configuration information that was last saved (see *Saving or Rejecting Configuration Setting Changes* on page 77). To retrieve system information, open the SYSTEM STATUS - SYSTEM INFORMATION PAGE, then print it on your local printer. File the resulting printout in a safe place.

The screenshot shows a web browser window titled "EasyMenu Web Manager - Microsoft Internet Explorer" with the address "http://206.86.208.21/". The main content area displays "RadioNet CampusLINK Manager® 1998". On the left is a navigation menu with links like "Home", "System Features", "System Configuration", etc. The main content is titled "System Status - System Information Page" and contains a table of system information.

System Status - System Information Page	
Product Name	CampusLINK
System Name	Wireless Bridge
System Contact	Administrator
System Location	RadioLAN
Radio Port Mac Address	00:a0:4d:30:03:b5
Ethernet Port Mac Address	00:a0:4d:03:03:b5
Subnet ID	1234
IP Address	206.86.208.21
Subnet Mask	255.255.255.0
Default Gateway IP Address	206.86.208.1
Boot Software Version	01.00
System Software Version	2.01 (Jun 22 1998 17:52:18)
System Software File Name	wm201
Hardware Revision	AA
System Serial Number	00A0D43003B5
System Up Time (Days:Hours:Minutes:Seconds)	0:3:54:28

© Copyright 1998 RadioLAN, Inc. All Rights Reserved.

Figure 46: System Information Page

The SYSTEM INFORMATION PAGE includes the following information:

Product Name	States the product name.
System Name	States the system name entered on the ADMINISTRATION PARAMETERS PAGE.
System Contact	States the system contact entered on the ADMINISTRATION PARAMETERS PAGE.
System Location	States the system location entered on the ADMINISTRATION PARAMETERS PAGE.
Radio Port MAC Address	This information is loaded into the CPU from the factory. The information in this field should match the MAC Address noted on the bottom of the CPU.
10BaseT Port MAC Address	This information is loaded into the CPU from the factory. The information in this field should match the MAC Address noted on the bottom of the CPU.
Subnet ID	This information was entered on the RADIO PORT PARAMETERS PAGE.
IP Address	States the IP Address entered on the IP PARAMETERS PAGE, or DHCP assigned IP Address if DHCP support is enabled (see <i>DHCP Support</i> on page 41).
Subnet Mask	States the subnet mask entered on the IP PARAMETERS PAGE.
Default Gateway IP Address	States the default gateway entered on the IP PARAMETERS PAGE.
Boot Software Version	States the boot software version stored in the CPU.
System Software Version	States the software version that the CPU is currently using.

System Software File Name	States the system software file name.
Hardware Revision	States the hardware version of the CPU.
System Serial Number	States the CPU's serial number.
System Up Time	States the day, hours, and minutes that the system has been in operation.

Viewing the System Log

The SYSTEM LOG PAGE collects system events like system starts, restarts, and password authentication messages. The screen displays a list with the following columns:

- Item** Displays the item number on the list. As new events appear, the CPU issues a new number.
- Task** Lists the task that initiated the message.
- Time (Sec)** Time in seconds, since the CPU was restarted.
- Error Message** Lists a verbose error name.



Figure 47: System Log Page

Managing the CPU Locally

You can connect a serial device such as a VT-100 terminal, a PC using terminal software, or dial-up modem to the CPU as an alternative method of managing the CPU.

Using this method, you can communicate with the CPU to make configuration changes or to interrogate the CPU for performance statistics.

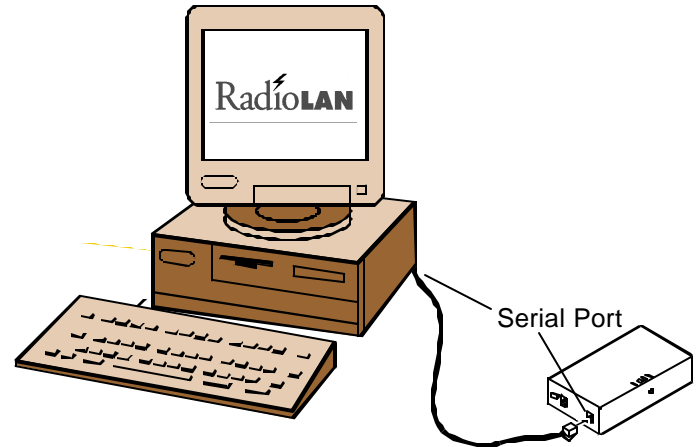

Figure 48: Connecting the VT-100 Terminal to the CPU

The CPU uses an RJ11 jack for connection to the terminal. The CPU requires a special interface cable that connects between the serial port jack and a DB9F serial connector. The pin-outs for this cable are shown in Table 1.

Signal Description	DB-9F	RJ11	Signal Description
Ground	2	1	Ground
Serial Out (from computer)	3	2	Rx In
Serial In (to computer)	5	4	Tx out

Table 1: Serial Port Adapter Cable Pin-outs

CPU Local Management

The CPU Local Management menu allows you to view screens that contain configuration information about the CPU. Using this menu, you can assign passwords, set up IP Addresses for the CPU and SNMP message Traps, set address filters, test system performance, and view system performance statistics.

When using the CPU Local Management software to make changes, edit your choices on the screens, then accept all session changes by accessing the SYSTEM CONFIGURATION - CONFIGURATION CHANGES PAGE. This causes the CPU to store configuration changes.

Hot Keys

Throughout the program you will find **hot keys**. These specific keyboard combinations allow you to move about the program easily and quickly. Each screen contains a specific grouping of hot keys. Options available through the program are:

Enter Make a selection from available options by highlighting the item you want and pressing the **Enter** key. You should also use this key to enter your typed response.

Backspace The **Backspace** key on your keyboard allows you to move to the screen displayed previously.

Logging onto the CPU Configuration Screen

The LOGON SCREEN provides security to CPU configuration items. There are three fields on the screen:

- Serial Number
- Enter User Name
- Enter Password

If the password is not set, the following message will appear at the bottom of the screen:

`(Password is not set, hit any key to proceed)`

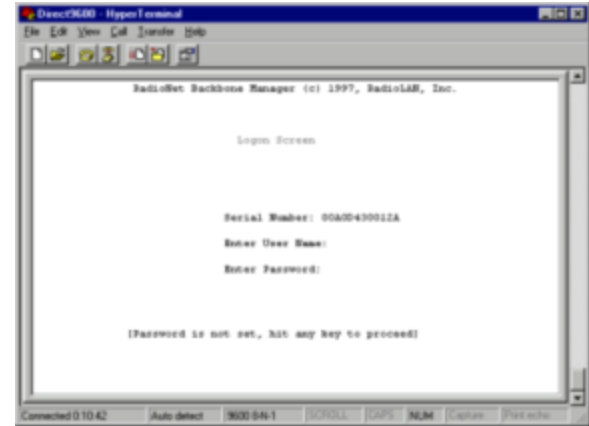

Figure 49: Logon Menu

If this message appears, press any key to enter the program, then set the access security features by going immediately to the SYSTEM CONFIGURATION - ACCESS SECURITY PAGE.

Serial Number

The Serial Number field is a read-only field that reports the CPU's serial number.

Enter User Name

The Enter User Name field is an entry field into which you enter your user name to gain access to the configuration and diagnostic screens. Only entries matching those programmed into the SYSTEM CONFIGURATION - ACCESS SECURITY PAGE are allowed access to the program.

Enter Password

The Enter Password field allows you to enter your user password for access to configuration and diagnostic screens. Enter your password here and then press **Enter** to enter the program.

If the user name and password match those stored in the ACCESS SECURITY PAGE, you will be allowed to view and edit items on the screen. If you make entries that do not match those stored in the program, you will remain on the LOGON SCREEN.

Using the Main Menu

After gaining access from the LOGON SCREEN, the main menu appears. This menu lists all major sections of the program. The following items appear:

- | | |
|-----------------|-----------------------------------------------------------------------------------------------------------------------------------------------------------------------------------------|
| Node Discovery | Displays the signal quality of the wireless link. |
| System Features | Takes you to the SYSTEM FEATURES menu, where you can add enhanced features like Data Encryption. See <i>SYSTEM OPERATION MODE</i> on page 99 for more information about this selection. |

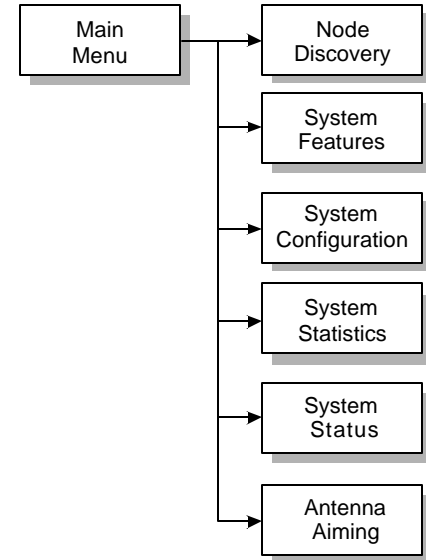

Figure 50: The Main Menu

System Configuration	Leads you to configuration items, such as access security, SNMP parameters, and port parameters. See <i>Working with the System Configuration Menu</i> on page 91 for more information about this selection.
System Statistics	Allows you to see the historical performance of the CPU. See <i>SYSTEM STATISTICS MENU</i> on page 103 for more information about this selection.
System Status	Allows you to interrogate the CPU for current system performance information. See <i>SYSTEM STATUS MENU</i> on page 107 for more information about this selection.
Diagnostics	Allows you to fine-tune the alignment between directional antennas. See <i>DIAGNOSTICS MENU</i> on page 106 for more information about this selection.

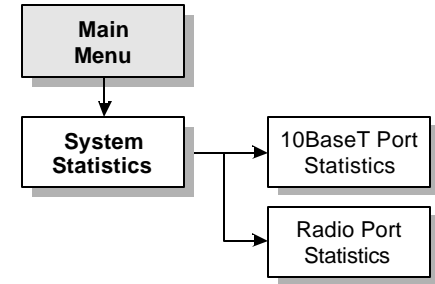

Figure 51: System Statistics Menus

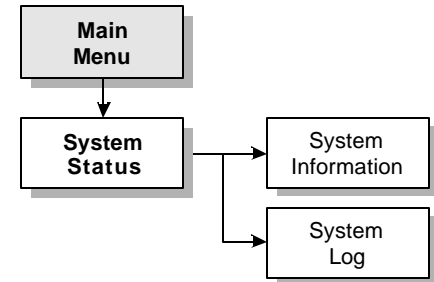

Figure 52: System Status Menus

Working with the System Configuration Menu

After selecting System Configuration on the main menu, the System Configuration menu appears, allowing you to set up a number of CPU network functions. The menu contains the following items:

Administration Parameters

This selection leads you to the ADMINISTRATION PARAMETERS menu, from which you can identify the system name, the person who is responsible for the CPU, and the location where the CPU is installed. This information is useful when you access the CPU from remote locations using SNMP and HTML communication. See *ADMINISTRATION PARAMETERS MENU* on page 95 for more information about this selection.

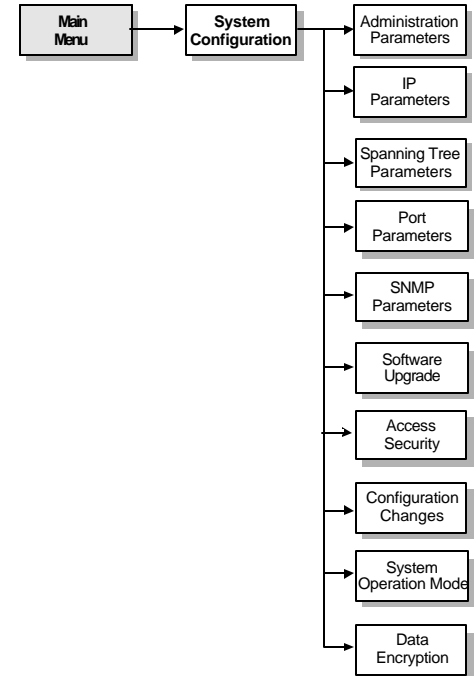

Figure 53: System Configuration Menu

IP Parameters

This item displays the IP PARAMETERS menu, from which you assign the CPU's IP Address for the 10BaseT Network. You can also enable DHCP support here. See *IP PARAMETERS* on page 96 for more information about this selection.

Spanning Tree Parameters

This item displays the SPANNING TREE PARAMETERS menu, where you can set up options for Spanning Tree Parameters. See *SPANNING TREE PARAMETERS MENU* on page 102 for more information about this selection.

Port Parameters

Selecting this item displays the PORT PARAMETERS menu, from which you can choose to set up 10BaseT or radio port (wireless link) options. See *10BASET (AND RADIO) PORT PARAMETERS MENU* on page 100 for more information about this selection.

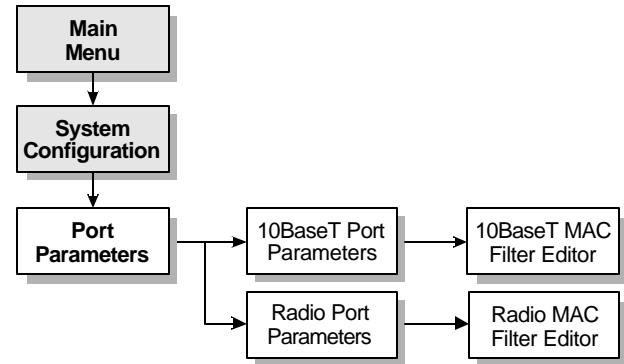

Figure 54: Port Parameters Menus

SNMP Parameters

This item displays the SNMP PARAMETERS menu, where you can set IP Addresses and other items related to SNMP management.

Software Upgrade Parameters

Selecting this item displays the SOFTWARE UPGRADE menu, at which you can specify the IP Address of a TFTP server where you can download software updates to the CPU. See *SOFTWARE UPGRADE MENU* on page 104 for more information about this selection.

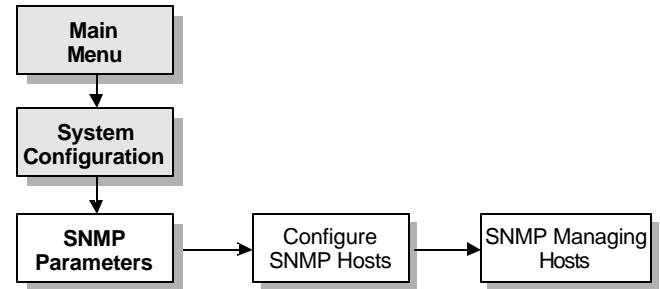

Figure 55: SNMP Parameters Menus

Access Security	This selection leads you to the ACCESS SECURITY menu, from which you can assign logon names and passwords for up to three users. See <i>SYSTEM CONFIGURATION – ACCESS SECURITY MENU</i> on page 95 for more information about this selection.
Configuration Changes	After making changes to selections on menus, select this option to display the CONFIGURATION CHANGE menu, from which you can permanently save your changes, or revert back to the last saved settings. See <i>SYSTEM CONFIGURATION – CONFIGURATION CHANGES MENU</i> on page 105 for more information about this selection.
System Operation Mode	This selection allows you to set the operational characteristics of the CPU. Here, you can configure the CPU as an access point, or a 10BaseT Network interface card translator to wireless networking. See <i>SYSTEM OPERATION MODE</i> on page 99 for more information about this selection.
Data Encryption	This selection leads you to the DATA ENCRYPTION menu, from which you can enable Data Encryption and set the encryption key. See <i>DATA ENCRYPTION MENU</i> on page 99 for more information about this selection.

Configuration Manager Menu Items

The following table lists each menu name and menu item, and gives a brief note for items in the Configuration Manager menus. For a further explanation of an item on the list, see the **Refer to** column, which states the section name and page number where you can find the explanation.

Menu Name	Menu Item	Refer to:	Notes
SYSTEM CONFIGURATION – ACCESS SECURITY MENU		<i>Setting Up Security Features</i> on page 35	Allows you to set menu logon names and passwords for access to menus.
	User Logon Name	<i>User Logon Name Fields</i> on page 35	Enter from 1 to 12 letters or numbers.
	User Password	<i>The User Password and Retype Password Fields</i> on page 35	Enter from 1 to 12 letters or numbers.
ADMINISTRATION PARAMETERS MENU		<i>Administration Parameters</i> on page 37	Allows you to specify system identification information.
	System Name	<i>System Name</i> on page 38	Enter from 1 to 15 letters or numbers.

Menu Name	Menu Item	Refer to:	Notes
	System Contact	<i>System Contact</i> on page 38	Enter from 1 to 15 letters or numbers.
	System Location	<i>System Location</i> on page 38	Enter from 1 to 15 letters or numbers.
IP PARAMETERS		<i>IP Parameters</i> on page 39	Allows you to set network addresses.
	IP Address	<i>IP Address</i> on page 40	Identifies the CPU on a TCP/IP network. The first segment can range from 0 to 223, each other segment ranges from 0 to 255 (for example, 221.142.15.200).
	Subnet Mask	<i>Subnet Mask</i> on page 40	Determines the Subnet Mask Address for the CPU. The first segment can range from 0 to 223, each other segment ranges from 0 to 255 (for example, 223.142.15.200).

Menu Name	Menu Item	Refer to:	Notes
	Default Gateway IP Address	<i>Default Gateway IP Address</i> on page 40	The first segment can range from 0 to 223, each other segment ranges from 0 to 255 (for example, 223.142.15.200).
	DHCP Operation Mode	<i>DHCP Support</i> on page 41	Enables and disables DHCP support, and allows you to connect to a DHCP Server. By default, this option is selected.
	DHCP Server IP Address	<i>DHCP Server IP Address</i> on page 42	The first segment can range from 0 to 223, each other segment ranges from 0 to 255 (for example, 223.142.15.200).
SNMP PARAMETERS MENU		<i>SNMP Parameters</i> on page 43	Contains fields that specify the SNMP management and notification parameters.
	Read Community	<i>Read Community</i> on page 44	Enter up to 31 letters or numbers or symbols.

Menu Name	Menu Item	Refer to:	Notes
CONFIGURING SNMP HOST MENU	Write Community	<i>Write Community</i> on page 44	Enter up to 31 letters or numbers or symbols.
	Enable Authentication Trap	<i>Enable Authentication Trap</i> on page 44	Choose Yes or No .
	Configure Managing Hosts		Leads to CONFIGURE SNMP HOSTS menu.
		<i>Configuring SNMP Managers for the CPU</i> on page 45	Allows you to add up to five SNMP Manager stations that can control, interrogate, and receive Traps from the CPU.
	Managing Host IP Address	<i>Configuring SNMP Managers for the CPU</i> on page 45	The first segment can range from 0 to 223, each other segment ranges from 0 to 255 (for example, 220.142.15.200).
	Managing Host Access Right	<i>Setting Access Rights for SNMP Managers</i> on page 46	Choose Get only or Get and Set .
	Enable Trap Receiving	<i>Directing Traps to Manager Stations</i> on page 46	Choose Yes or No .

Menu Name	Menu Item	Refer to:	Notes
	Enable System Log Receiving	<i>Directing the System Log to Manager Stations on page 46</i>	Choose Yes or No .
	Add this Managing Host		Adds the management station settings to the CPU's management database.
SNMP MANAGING HOSTS			Displays information about CPU configured Manager stations.
SYSTEM OPERATION MODE		<i>Setting the CPU's Mode of Operation on page 47</i>	Allows you to set up the method that you will use for operating the CPU.
	Point-to-Point Mode	<i>Point-to-Point Mode on page 47</i>	Sets the CPU for use in Campus BridgeLINK™ applications.
SYSTEM FEATURES MENU	Software Upgrade Key	<i>Securing the CPU with Data Encryption on page 48</i>	Allows you to enter a key to add an enhanced feature like Data Encryption.
DATA ENCRYPTION MENU		<i>Securing the CPU with Data Encryption on page 48</i>	Allows you to secure wireless data by using Data Encryption.

Menu Name	Menu Item	Refer to:	Notes
SYSTEM CONFIGURATION - PORT PARAMETERS MENU	Enable Encryption	<i>Data Encryption Enabled Check Box</i> on page 48	Choose Yes or No .
	Encryption Key	<i>Encryption Key</i> on page 48	Enter the encryption key.
	10BaseT Port Parameters Menu	<i>Bridging the Link and 10BaseT Networks</i> on page 49	This menu leads to port parameters menus for the Radio and 10BaseT ports.
10BASET (AND RADIO) PORT PARAMETERS MENU	Radio Port Parameters Menu	<i>10BaseT Port Parameters</i> on page 51	Displays the 10BASET PORT PARAMETERS menu.
		<i>Radio Port Parameters</i> on page 54	Displays the RADIO PORT PARAMETERS menu.
		<i>10BaseT Port Parameters</i> on page 51, or <i>Radio Port Parameters</i> on page 54	Displays the port's name, allows you to enable or disable network filters, and allows you to add, modify, and delete MAC Address filters.
	Port Name	<i>Port Name</i> on page 54	Enter up to 12 letters or numbers.

Menu Name	Menu Item	Refer to:	Notes
	Subnet ID	<i>Subnet ID</i> on page 55	Available in RADIO PORT PARAMETERS menu only. Enter four characters.
	Block MAC Packets	<i>MAC Address Filter</i> on page 51	Choose Yes or No .
	Edit MAC Filters	<i>Edit Button</i> on page 52	This item leads to the EDIT MAC FILTERS menu.
	Block IP Packets	<i>Block IP Packets</i> on page 52	Choose Yes or No .
	Block IPX Packets	<i>Block IPX Packets</i> on page 53	
	Block NetBEUI Packets	<i>Block NetBEUI Packets</i> on page 53	Choose Yes or No .
	Block NetBIOS Packets	<i>Block NetBIOS Packets</i> on page 53	Choose Yes or No .
MAC FILTERS MENU			
	Filter Physical Address	<i>MAC Address</i> on page 58	Type the MAC Address to filter.
	Filter Mask Bytes	<i>Mask Bytes</i> on page 59	Enter the Mask bytes for the network node.

Menu Name	Menu Item	Refer to:	Notes
SPANNING TREE PARAMETERS MENU	Source or Destination Address Filtering	<i>Source/Dest.</i> on page 59	Allows you to specify whether the action upon packets will be occur if that node is sending or receiving packets.
	Accept or Reject The Packet When Satisfied	<i>Accept</i> on page 60	Allows you to allow or disallow transmission of the packet depending upon the entry in the field.
	List all Filters Configured	<i>Adding MAC Filters</i> on page 60	Selecting this item displays the filter list.
		<i>Spanning Tree Parameters</i> on page 62	Allows you to set up bridging characteristics for the BBL.
	Bridge Priority	<i>Bridge Priority (0–65,535)</i> on page 63	Enter a number from 0 to 65,535.
	Hello Time (1–10)	<i>Hello Time (1–10)</i> on page 64	Enter a number from 1 to 10.

Menu Name	Menu Item	Refer to:	Notes
	Forward Delay Time (4–30)	<i>Forward Delay Time (4–30)</i> on page 64	Enter a number from 4 to 30.
	Max. Age Time (6–40)	<i>Max. Age Time (6–40)</i> on page 65	Enter a number from 6 to 40.
	Port Priority (0–255)	<i>Port Priority (0–255)</i> on page 66	Enter a number from 0 to 255.
	Port Path Cost (1–65,535)	<i>Port Path Cost (1–65,535)</i> on page 66	Enter a number from 1 to 65,535.
10BASET (AND RADIO) MAC FILTER LIST		<i>Managing Packet Flow Through the CPU</i> on page 57	
SYSTEM STATISTICS MENU		<i>Interrogating the System for Performance Information</i> on page 67	This menu leads you to port statistics menus for the 10BaseT and radio port.
	10BaseT Port Statistics	<i>Checking 10BaseT Port Statistics</i> on page 68	This item displays the 10BASET PORT STATISTICS menu.
	Radio Port Statistics	<i>Checking Radio Port (Wireless Link) Statistics</i> on page 71	This item displays the RADIO PORT STATISTICS menu.

Menu Name	Menu Item	Refer to:	Notes
10BASET PORT STATISTICS MENU		<i>Checking 10BaseT Port Statistics</i> on page 68	Allows you to interrogate the system remotely about current traffic statistics on the 10BaseT port.
RADIO PORT STATISTICS MENU		<i>Checking Radio Port (Wireless Link) Statistics</i> on page 71	Allows you to interrogate the system remotely about current traffic statistics on the radio port.
SOFTWARE UPGRADE MENU		<i>Upgrading System Software</i> on page 74	Allows you to download a new configuration to the CPU.
	Download Mode	<i>Upgrading System Software</i> on page 74	Allows you to choose the Download mode. Choices are serial (xmodem) and TFTP.
	TFTP Server IP Address	<i>TFTP Server IP Address</i> on page 76	Allows you to enter the IP Address of the TFTP server where the CPU will retrieve the file.

Menu Name	Menu Item	Refer to:	Notes
	System Software Filename	<i>System Server Filename</i> on page 75	Allows you to enter the file name of the operating system file that you want to download.
	Perform Download	<i>Download Button</i> on page 76	Causes the CPU to retrieve the specified software file from the specified TFTP server IP Address or from the serial port.
SYSTEM CONFIGURATION – CONFIGURATION CHANGES MENU		<i>Saving or Rejecting Configuration Setting Changes</i> on page 77	Allows you to save your changes or to reject changes you have made, which allows the CPU to continue operating as before you accessed this screen.
	Save All Configuration Changes	<i>Save All Changes</i> and Reset on page 78	All changes that you have made during this session overwrite previous program entries and the unit resets.

Menu Name	Menu Item	Refer to:	Notes
	Reload All Previous Configurations	<i>Reload Last Saved Configuration</i> on page 78	Abandons all changes that you have made and change entries back to their original settings.
	Reset All Configuration Changes	<i>Reset Configuration to Factory Default</i> on page 78	Resets all configuration items to their factory default settings.
DIAGNOSTICS MENU		<i>Aiming the Directional Antennas</i> on page 33	Allows you to fine-tune the alignment of two directional antennas.
	Ping Destination	<i>Selecting the Distant CPU's Address</i> on page 34	Allows you to enter the Explicit Address for the Distant CPU.
	Ping Frame Size	<i>Setting the Frame Size</i> on page 34	Sets frame size transferred during the PING test.
	Estimated Distance	<i>Setting the Estimated Distance between Antennas</i> on page 34	Allows you to select the estimated distance between directional antennas.

Current	<i>Viewing or Hearing Status of the Link on page 34</i>	Displays the percentage of frames that successfully reached the distant antenna.
Best	<i>Viewing or Hearing Status of the Link on page 34</i>	Displays the best transfer rate detected during the alignment.
Worst	<i>Viewing or Hearing Status of the Link on page 34</i>	Displays the worst transfer rate detected during the alignment.
Perform Ping	<i>Starting and Stopping the Test on page 34</i>	Select Start to begin, or Stop to end the test.

SYSTEM STATUS MENU

	<i>Recording Important System Information on page 80</i>	Leads you to SYSTEM INFORMATION and SYSTEM LOG.
System Information	<i>Recording Important System Information on page 80</i>	Displays the System Information menu, at which you can collect version, contact, and other information about the CPU.

System Log

Viewing the System Log on page
83

Displays the System Log. The log stores and displays system events such as system start, warm start, or password authentication.

Troubleshooting

This section discusses ways to eliminate trouble on the wireless link. We will provide cross-references to other sections of the manual, which support corrective action.

The CPU bridges traffic between the wireless link and wired-backbone network. The unit provides several indicators of its status and, with either a serial terminal or Web-based access, a user can use the tools built into the CPU to further examine the network connection and help troubleshoot a problem report.

Indicators

In normal operation, verify that the power, 10BaseT, and radio connectors are attached. Verify that the Power LED is illuminated, that the Status 1 LED is illuminated, and the Status 2 LED flickers when data is moving across the link. If any of these do not operate as described, it may indicate a problem. For more information about indicators, see *LED Indicator* on page 3. Contact your distributor for assistance. If you cannot reach your distributor, or purchased the units directly from RadioLAN, contact RadioLAN Support.

Problem: No traffic for anyone

Using either the VT100, or Web management tools, check that the configuration is set correctly. Verify that the filters are not set to block all traffic, or stop a specific protocol (see *Bridging the Link and 10BaseT Networks* on page 49). Examine the statistic counters (see *Interrogating the System for Performance Information* on page 67), and use the ANTENNA AIMING page (see *Aiming the Directional Antennas* on page 33) to “see” the quality of the wireless link’s signal. Verify that the Subnet ID on each CPU is set to the same value. If using the Data Encryption option, verify that both CPUs use the same encryption key, and that Data Encryption is enabled.

Problem: Radio Range seems less than it should be.

Check the placement of the directional antenna. Generally, the higher on the wall it is placed, the better the signal pattern will be. If this link has been working for some time, inspect the antenna to see if it has been moved out of alignment. Check the line of site between directional antennas to verify that no new construction or tree growth has occurred, blocking the directional antenna link

If the problem persists and you have access to another CRM, try replacing the CRM. If this makes a difference, it is possible the CRM may have become damaged, reducing its effectiveness. Contact your distributor for assistance.

Problem: Retransmissions are excessive.

Verify that you selected and saved the correct Estimated Distance on the ANTENNA AIMING page (see *Aiming the Directional Antennas* on page 33). This also sets internal CPU transmission timers. Using an incorrect setting can cause retransmissions, which reduce the link's efficiency and speed.

Glossary

Access Point

A service allowing wireless client stations to exchange data with an existing 10BaseT hard-wired Ethernet Network.

Agent

Software at the device being controlled. The agent monitors the status of objects in an information base called the MIB. The agent can be programmed to act on status changes and send notification messages, called Traps, to designated IP Addresses called Trap communities.

The agent can also take instructions from a remote manager to make changes to objects in the MIB. For example, the manager might instruct the agent to change the system date and time.

Client Station

A wireless 10Mbps computer that receives and originates Ethernet data. Client stations may exchange data directly and/or send to other hard-wired network devices by using an access point service.

<i>DHCP Server</i>	A protocol software that manages and tracks the assignment and use of static and dynamic IP Addresses to devices attempting to connect to a network.
<i>DNS</i>	A system, which transfers a location's alphanumeric URL address into the site's corresponding numerical IP Address.
<i>Domain</i>	A grouping of devices that are members of a specific realm or location on a network. Each device is identified on the Internet by a specific extension attached to the location's IP Address which is shared among all devices within the domain.
<i>Gateway</i>	A doorway to the Internet that allows a member of one domain access another domain. (The domains have different IP Addresses.)
<i>IP Address</i>	Internet Protocol Address. Numerically based address of Internet sites. It is composed of four numbers (0-255) that are linked by a period. For example, 234.8.44.155. The numbers in the address indicate the domain of the site and the user of that site. Such an address can be assigned by a private network administrator for a private network but, for use on a larger scale, one should obtain an address from the InterNIC Registration Service which assigns a different address to each user.
<i>MAC Address</i>	Media Access Control Address. Basic numerical address used to identify all types of nodes on networks based on the IEEE 802 standards. Protocols may assign to nodes different addresses that coincide with their system. Ultimately, however, that address can be traced to

the node's MAC Address. This address is also referred to as a Data Link Control address by OSI Reference-based networks.

Manager

Software used to control and manipulate the Management Information Bases (MIB) through communication with the agent.

MIB

Management Information Base. A database of information about a particular community within a network including information about the activities of that community. This information can be reviewed for understanding of activities of the MIB and troubleshooting.

Node

Any device connected to a network. It is assigned either a MAC Address (IEEE 802 Standard network) or a DLC Address (OSI Reference network).

Packets

A portion of a file being sent over the Internet. The portion contains part of the original file and the destination IP Address for the document.

PING

Packet Internet Groper. A program used for verifying/testing network connectivity between two or more computers by transmitting a special diagnostic packet to those stations on the network. It forces the receiving station to send a reply indicating that the packet reached its destination. It obtains information about the connection, by determining the amount of time for packet delivery and station response.

Routing

The path chosen by the user over which to send a packet of information from one computer or station to another via the network.

Subnet Mask

A network address that numerically represents the IP Address, including the network address

and the subnet of which the IP Address is a member.

TCP/IP

Transport Control Protocol/Internet Protocol. The combination of protocols that are used on the Internet to transfer data from one address to another.

Appendix A: Indicators, Switches, and Connectors

Indicators

10BaseT Port LEDs

There are two built-in LEDs located on the 10BaseT connector which provide link and port activity information.

- The CAR LED (green) is active when the port is connected to another powered 10BaseT port whose signaling meets the requirements for an IEEE 802.3i 10BaseT device (for example, valid link test pulses are detected on the receive pair).
- The ACT LED (green) is active when receive activity is detected or during a packet transmission.

Power LED

The Power LED (green) is active when power is provided to the unit.

Fault LED

The fault LED (amber) is active when a fault is detected during power up diagnostics.

Status LEDs

The green Status 1 LED illuminates when the CPU detects the presence of the distant CPU. When the CPU is operating, this LED normally illuminates when the near and far CPUs are active.

The green Status 2 LED illuminates when the CPU detects the presence of data passing through the wireless link. During normal CPU operation, this LED flickers when near and far CPUs are active.

MDI/MDI-X Switch

Interconnection on a 10BaseT Network must always be between MDI to MDI-X. The transmitter of each device must connect to the receiver of the other device. The reversal of the transmitter and receive assignments is called a **crossover function**. Every 10BaseT interconnection requires a crossover function. Generally, 10BaseT ports on an adapter card are configured as MDI, and 10BaseT ports on a repeater/hub are configured as MDI-X.

The CPU allows you to configure its 10BaseT port as an MDI (switch out position) or MDI-X (switch in position) port. The abbreviation MDI stands for Media Dependent Interface, and is specified by the IEEE 802.3i 10BaseT standard to be the electrical and mechanical interface to the UTP wire. An MDI port transmits out to the UTP wire on pins 1 and 2, and receives from the UTP wire on RJ-45 pins 3 and 6.

The MDI/MDI-X switch swaps the pin assignments of transmit and receive data wire pairs for the 10BaseT port. MDI-X configuration is used when the remote end of the wire is connected to a network station (for example, a 10BaseT adapter card) or to an MDI port on a 10BaseT concentrator. MDI configuration is used when the remote end of the wire is connected to a 10BaseT concentrator.

I/O Connectors

10BaseT connector

The 10BaseT interface is provided through a shielded RJ-45 connector, which can be configured by way of the MDI/MDI-X switch. The pin-out is described in the following table and figure:

Pin #	Signal (MDI configuration)	Signal (MDI-X configuration)
1	TX+ (Transmit to UTP)	RX+ (Receive from UTP)
2	TX- (Transmit to UTP)	RX- (Receive from UTP)
3	RX+ (Receive from UTP)	TX+ (Transmit to UTP)
4	No connection	No connection
5	No connection	No connection
6	RX- (Receive from UTP)	TX- (Transmit to UTP)
7	No connection	No connection
8	No connection	No connection

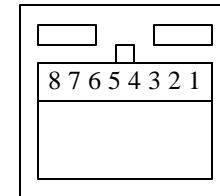

Serial Port Connector

The serial port interface is provided through a four-pin RJ-11 connector. You can connect the serial port to a DB9 jack using a cable with a four-pin modular connector on one end, and a DB9F connector on the other. The pin-out is described in the following table and figure:

Signal Description	DB-9F	RJ11	Signal Description
Ground	2	1	Ground
Serial Out (from computer)	3	2	Rx In
Serial In (to computer)	5	4	Tx out

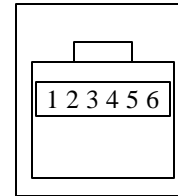

Appendix B: Technical Specifications

Network Protocol

10 Mb/s Manchester encoded (IEEE 802.3 CSMA/CD)

RadioLAN/10™ Pulse Modulated (CSMA/CA)

Standards Support

IEEE 802.3i Type 10BaseT

Electrical Specifications

	Domestic	International
Input Power:	18 Watts	18 Watts
AC Line Frequency:	60 Hz	50-60 Hz
Input Voltage:	110VAC	100-240VAC
Volt Amperes Rating:	0.5A @ 115VAC	0.3A @ 230VAC

Physical Specifications

Dimensions

6.375" x 4.1875" x 13.125"

Weight

22.3 oz. (632g)

Environmental Specifications

Operating Temperature: 5 C to 40 C

Storage Temperature: -25 C to 70C

Operating Humidity: 85% max. relative humidity, non-condensing

Storage Humidity: 95% max. relative humidity, non-condensing

Operating Attitude: 10,000 ft (3,000m) maximum

Electromagnetic Emissions

Meets requirement of:

FCC Part 15, Subparts A and B, Class A

EN55 022 (CISPR 22:1985), Class A

General License VDE 0871, Class A (AmtsbIVfg No. 243/1991 and Vfg 46/1992)

VCCI Class 1 ITE

Safety Agency Approvals

UL-listed, ULC-listed, CSA-certified, TUV-licensed

Getting Technical Support

If you have technical questions or have determined that your equipment is damaged, RadioLAN offers a number of ways to get assistance:

1. Contact your local RadioLAN reseller from which you purchased the product.
2. See the RadioLAN Web Site for technical assistance:
<http://www.radiolan.com>
When your browser accesses the Web Site, click Technical Support.
3. You can reach RadioLAN Technical Support directly, by dialing:
Toll free: 888-2-RADIOLAN (888-272-3465), or (408) 616-6333
4. Alternatively, you can reach our technical staff at the following e-mail address
support@radiolan.com

Please have the following information available and ready:

- Your name, address, and phone number
- The serial number of the RadioLAN part in question
- A description of the problem that you are experiencing

Technical Support may ask you to run tests and give results of those tests. It is therefore best if you are located as close as possible to the CPU when you call.

Index

1

- 10BaseT (and Radio) MAC Filter List menu, 112
- 10BaseT (and Radio) Port Parameters menu, 110
- 10BaseT LED indicators, 15
- 10BaseT Networks, 58. *See also* networks
 - browser requirements, 36
 - configuring, 60
 - connections, 15, 66
 - getting performance information, 77
 - IP Address assignment and, 23
 - transmit/receive switch, 14
- 10BaseT port, 15
- 10BaseT Port MAC Filter Edit Page, 66
- 10BaseT Port Parameters menu, 109
- 10BaseT Port Parameters Page, 60
- 10BaseT Port Statistics command, 113
- 10BaseT Port Statistics menu, 113
- 10BaseT Port Statistics Page, 77

A

- AC line frequency, 128
- Accept Packet command, 111
- access rights
 - remote stations, 53
 - SNMP Managers, 55
- Access Security menu, 104
- Access Security Page, 44
- ACT LED, 15
- activity information, 124
- Add this Managing Host command, 108
- adding user names and passwords, 44
- addresses. *See* IP Address; MAC address
- Administration Parameters menu, 100, 104
- Administration Parameters Page, 46
- administrators, 46
 - dynamic addressing and, 50
- agent, 35
 - assigning IP Address, 49
 - configuring, 45, 54
 - creating IDs for system, 47

- remote traps and, 52
- aligning antennas, 33
- amperes rating, 128
- anchoring devices, 29
- angle of operation, 12
- antenna, 12, 18
 - attaching to CRM, 17
 - grounding, 30
 - improving signal quality, 42
 - mounting, 31
 - Sighting, 33
- Antenna Aiming menu, 115
- Antenna Aiming page, 42
- antenna cable, 19
 - attaching to CRM, 27
- assigning access rights
 - remote stations, 53
 - SNMP Managers, 55
- assigning IP Address
 - default gateway, 49
 - to CPU, 22, 24
 - to SNMP agent, 49
- attaching to CPU, 38
- authentication, 36, 52
 - enabling/disabling, 53

B

- baud rates, 65
- Best command, 116
- Block IP Packets command, 110
- Block IPX Packets command, 110
- Block MAC Packets command, 110
- Block NetBEUI Packets command, 110
- Block NetBIOS Packets command, 111
- bridge, 71, 118
 - configuring, 72
 - port priority setting, 75
 - transmitting frames, 74
- bridge priority, 72
- Bridge Priority command, 112
- Bridging Parameters menu, 112
- browser, 36

C

cables, iii, 19, 29, 94

Campus BridgeLINK

- operational modes, 56
- setting up, 20, 21, 25, 32
- system components, 13
- technology overview, 11

Campus BridgeLINK™ Manager, 37

- getting system information, 89
- keyboard shortcuts, 95
- logging onto, 38
- main menu, 40, 98
- main screen, 41

Campus BridgeLINK™ Processor Unit. *See* CPU

CAR LED, 15

case sensitivity, 44

changing system configuration, 37, 86, 88

- preventing SNMP Manager from, 55

Cold Start notification, 52

collision error packets, 78

communications

- getting performance information, 77, 80
- optimizing, 61, 76

Companion Radio Module. *See* CRM

configuration

- 10BaseT networks, 60
- changing, 37, 86, 88
 - preventing SNMP Manager from, 55
- DHCP Server, 50
- hard-wired bridge, 72
- local connections, 15
- network-specific filters, 60, 63
- reverting to previously saved, 87
- saving changes, 87
- SNMP agent, 45, 54
- upgrades and, 83
- VT100 terminals, 65

Configuration Changes menu, 115

Configuration Changes Page, 37, 86

Configure Managing Hosts command, 107

Configure SNMP Host Page, 54

Configuring SNMP Host menu, 107

connections, 12, 58, 94

- 10BaseT networks, 15, 66

- attaching to CPU, 38

- CPU to hardware, 29

- IP Address assignment and, 23

- local configurations, 15

- multiple users and, 71

- remote stations, 35

- temporary, 23
- VT-100 terminals, 35, 93
- Windows systems, 62

connectors, 16, 17

- I/O pin assignment, 126
- serial pin assignment, 94
- troubleshooting, 118

Console Parameters Page, 65

contacting RadioLAN Technical Support, 131

CPU, 13, 58, 83

- 10BaseT interface, 15
- accessing from network, 38
- addressing, 63
- alternative management devices, 93
- electrical connections, 18
- getting performance information, 76
- hardware connections, 29
- installing, 25
- IP Address assignment, 22, 24
- mounting, 16, 26, 27
- operational modes, 56
- packet retransmission, 82
- powering up, 34
- rebooting, 85, 88
- selecting name and address, 43
- system requirements, 36

- TCP/IP management prerequisites, 22
- temporary connections, 23

CPU Name command, 116

CRC error checking, 78

CRM, 17

- attaching antenna cable, 27
- mounting, 28

CRM port, 16

crossover function, 125

customer assistance, 131

cyclical redundancy checks, 78

D

D connector, 16

Data Encryption, 35. *See also* security enabling, 57

Data Encryption menu, 103, 109

Data Encryption Mode command, 109

Data Encryption Page, 57

data filters, 60, 63

- adding, 69
- caution for setting, 66
- changing MAC, 70

Data Link Control address. *See* MAC Address

data loss precautions, 71

data packets. *See* packets
data transfers, 58, 71
 enabling/disabling, 66
 for remote users, 60
 large files and performance, 76
 remote performance and, 78, 81
 transmit rates, 81
Default Gateway IP Address command, 106
default settings, 87
Destination Address Filtering command, 111
devices, 93
 hard-wire external, 15
 networks and, 50
 port priority, 75
DHCP Operation Mode command, 106
DHCP Server
 assigning IP Address, 50
 disabling, 50
 getting IP Address, 50
DHCP Server IP Address command, 106
directional antenna. *See* antenna
distance guidelines, 21, 25, 36
documentation, iv
 typographic conventions, v
Download Mode command, 114
downloading software upgrades, 83

dynamic addressing, 50
Dynamic Host Configuration Protocol. *See* DHCP Server

E

Edit MAC Filters command, 110
electrical connections, 18
electrical specifications, 128
electromagnetic emissions, 130
Enable Authentication Trap command, 107
Enable Encryption command, 109
Enable System Log Receiving command, 108
Enable Trap Receiving command, 108
encryption, 35. *See also* security
 enabling, 57
Encryption Key command, 109
encryption keys, 57
entering user name and password, 39, 97
environmental specifications, 129
error codes, 92
Estimated Distance command, 116
Ethernet Networks. *See also* networks
 accumulated error count, 78
 LED indicators, 15
 packet transfers, 79
events, 92

Explicit Address command, 116
external devices, 15

F

factory default settings, 87
Fault LED, 13
FCC compliance, ii
files, transmitting large, 76
Filter Mask Address command, 111
Filter Physical Address command, 111
filtering databases, 66
filters, 60, 63

- adding MAC Address, 69
 - caution for setting, 66
 - changing MAC Address, 70

formats for IP Address, 49
Forward Delay Time command, 112
forward delay timing, 73
Frame Size command, 116
frames, resizing, 41
frequency, iii, 128

G

gateway

- default IP Address, 49
- getting default, 90

geographic locations (system IDs), 47
ground, 30

H

hardware version information, 91
hard-wired external devices, 15
hard-wired link, 71, 118

- configuring, 72
- transmitting frames, 74

Hello Time command, 112
hosts, 50

- configuring as SNMP agent, 54
- subnet mask and, 49

hot keys, 95
hub, 15

- CPU connections, 29

I

- I/O connectors, 126
- improving signal quality, 42
- indicators, 13, 15, 17
 - troubleshooting, 118
- input, 128
- installation, 25
 - directional antenna, 31
 - IP ASSIGN Utility, 24
 - location requirements, 12, 20, 21, 25, 31
- interface cable, 94
- interference, ii
- Internet, 49
- IP Address, 22
 - assigning
 - default gateway, 49
 - to CPU, 22, 24
 - to SNMP agent, 49
 - getting current, 90
 - getting for DHCP servers, 50
 - specifying for network devices, 50
- IP Address command, 105
- IP ASSIGN Utility, 23
 - installing, 24
- IP filters, 61

- IP Parameters menu, 101, 105
- IP Parameters Page, 48
- IPX filters, 62
- isolated networks, 49

K

- keyboard shortcuts, 95

L

- LAN. *See* networks
- LAN Manager servers, 62
- LED indicators, 13, 15, 17
 - troubleshooting, 118
- line frequency, 128
- List All Filters Configured command, 111
- local area networks. *See* networks
- Local Management menu, 95
- local port, 15
 - IP Address assignment and, 23
- location requirements, 12, 20, 21, 25
 - directional antenna, 31
- Logon page, 38, 96
- logs, 92

sending/receiving, 55

M

MAC Address, 58

- remote stations, 67
- wildcards and, 67

MAC Address filters, 60

- adding, 69
- caution for setting, 66
- changing, 70
- deleting, 70

MAC Filters menu, 111

main menu, 40, 98

Management Information Base. *See* MIB

Manager, 37

- getting system information, 89
- keyboard shortcuts, 95
- logging onto, 38
- main menu, 40, 98
- main screen, 41

Managing Host Access Right command, 108

Managing Host IP Address command, 107

mask bytes, 68

Max. Age Time command, 112

MDI/MDI-X selector button, 14

menus, 40, 98

- accessing items, 41

MIB, 35, 45

Microsoft Windows connections, 62

mode of operation, 56

modems, 35

mounting assemblies, 31

mounting bracket, 16

mounting height, 32

N

N connector, 17

NetBEUI filters, 62

NetBIOS filters, 62

Network Basic Input Output System. *See* NetBIOS

network browser. *See* Web browser

network devices, 50

network hub, 15

- CPU connections, 29

networks, 58. *See also* specific type; wireless stations

- addressing, 49
- administering remote stations, 46
- attaching to CPU, 38
- configuring, 60, 63
- dynamic addressing and, 50

- isolated and IP Addressing, 49
- multi-building locations and, 21
- optimizing performance, 71
- protocol for, 128
- shared resources and, 76

nodes, 58

- MAC Address assignment, 67

notification messages, 73. *See also* Traps

Novell IPX networks, 62

numbers as IP Address, 49

O

operating frequency, iii, 128

operational modes, 56

outages, 71

overrun packets, 79

P

packets, 58, 71

- collision counter, 78
- enabling/disabling transfers, 66
 - for remote users, 60
- encrypting, 57

- receiving from distant CPU, 82
- remote transfer checks, 78, 81
- retransmitting, 82
- shared network resources and, 76
- transmit rates, 81

passwords, 36

- adding, 44
- assigning to remote stations, 53
- entering, 39, 97
- not set, 96

Perform Download command, 114

performance, 66, 76

performance information, 35

- getting, 76

physical specifications, 129

pin assignment switch, 14

pin-outs

- I/O connector, 126
- serial connector, 94

Point-to-Point command, 108

Point-to-Point Mode, 56

Port Name command, 110

Port Parameters menu, 101, 109

- 10BaseT Port options, 60
- Console Port options, 65
- Radio Port options, 63

Port Path Cost command, 112

Port Priority command, 112

ports

- hard-wired link priority, 75

- local terminals, 15

- network-specific connections, 60, 63

- root bridge and redundant, 73

- serial access, 35

- setting baud rates, 65

- transmit/receive switch, 14

Power LED, 13

power ratings, 128

power transformer, 18

powering up the CPU, 34

Processor Unit. *See* CPU

protecting wireless stations, 35, 36

R

Radio Module. *See* CRM

Radio Port Parameters menu, 109

Radio Port Parameters Page, 63

Radio Port Statistics command, 113

Radio Port Statistics menu, 113

Radio Port Statistics Page, 80

Radio Unit

- getting performance information, 80

- locating, 20

- network-specific configurations, 63

RadioLAN MAC Address assignment, 67

RadioLAN Technical Support, 131

RadioLAN wireless network. *See* wireless stations

Read Community command, 107

rebooting system, 85, 88

reception, ii, 33

- testing, 43

registered IP Addresses, 49

Reject Packet command, 111

Reload All Previous Configurations command, 115

reloading previous configurations, 87

remote stations, 35, 37, 58

- administration, 46

- assigning access rights, 53

- data transfer performance, 78, 81

- enabling/disabling data transfers, 60

- getting performance information, 35

- viewing MAC Address, 67

remote Traps, 52

Reset All Configuration Changes command, 115

Reset Page, 88

resizing frames onscreen, 41

resources, 76

retransmissions, 82
RJ11 compatibility, 15
routing database, 74
runt packets, 79

S

safety approvals, 130
Save All Configuration Changes command, 115
Save Distance Parameters command, 117
saving system configurations, 87
screens, resizing frames, 41
security, 35, 36, 96

- enabling data encryption, 57
- setting up, 44

serial connector, 94
serial devices, 93
serial number, getting, 91, 97
serial port, 35
service tables, 66
setting up Campus BridgeLINK, 20, 21, 25, 32. *See also*
configuration
shared resources, 76
signal quality, 42
signals

- I/O connector, 126
- serial connector, 94

Simple Network Management Protocol. *See* SNMP
SNMP agent, 35

- assigning IP Address, 49
- configuring, 45, 54
- creating IDs for, 47
- remote traps and, 52

SNMP Manager, 35

- Administration Parameters options, 46
- IP Parameters options, 48
- notification parameters, 52
- setting access rights for, 55

SNMP Managing Hosts menu, 108
SNMP Parameters menu, 102, 107
SNMP Parameters Page, 52
Software Upgrade menu, 113
Software Upgrade Page, 83
Source Address Filtering command, 111
Spanning Tree Parameters Page, 71, 72
specs, 128
standards, 128
Start command, 116
starting Campus BridgeLINK™ Manager, 38
startup procedure (first time), 38
startup screen (Manager), 41
status indicators, 118

status information

- reception, 43

Status LEDs, 14

submenus, 41

Subnet ID command, 110

Subnet IDs, 64

- getting current, 90

subnet mask, 49

- getting current, 90

Subnet Mask command, 106

Successful % command, 116

system agent IDs, 47

system components, 13

system configuration

- 10BaseT networks, 60

- changing, 37, 86, 88

 - preventing SNMP Manager from, 55

- DHCP Server, 50

- hard-wired bridge, 72

- network-specific filters, 60, 63

- reverting to previously saved, 87

- saving changes, 87

- SNMP agent, 45, 54

- upgrades and, 83

- VT100 terminals, 65

System Configuration menu, 100

System Configuration screen

- 10BaseT Port Parameters Page, 60

- Access Security Page, 44

- Administration Parameters Page, 46

- Configuration Changes Page, 86

- Configure SNMP Host Page, 54

- Console Parameters Page, 65

- Data Encryption Page, 57

- IP Parameters Page, 48

- Radio Port Parameters Page, 63

- SNMP Parameters Page, 52

- Software Upgrade Page, 83

- Spanning Tree Parameters Page, 71, 72

- System Operations Mode Page, 56

system contact, 47

System Contact command, 105

System Features menu, 108

system indicators, 13, 15, 17

- troubleshooting, 118

system information, 89, 92

System Information command, 117

System Information Page, 89

System Location command, 105

System Log command, 117

System Log Page, 92

system logs, 92

- sending/receiving, 55
- System Name command, 105
- system names, 47
- System Operation Mode command, 103
- System Operations Mode Page, 56
- system requirements, 36
- System Software Name command, 114
- System Statistics menu, 113
- System Statistics screen
 - 10BaseT Port Statistics Page, 77
 - Radio Port Statistics Page, 80
- System Status menu, 117
- system upgrades, 83

T

- TCP/IP management services, 22
- TCP/IP Networks, 54. *See also* networks
- technical specifications, 128
- technical support, 131
- temperature, 129
- temporary connections, 23
- testing reception, 43
- TFTP Server IP Address command, 114
- TFTP Server upgrades, 84
- transmit rates, 81

- transmit/receive switch, 14
- transmitting large files, 76
- Traps, 52
 - sending/receiving, 55
- troubleshooting tips, 118

U

- unauthorized users, 35, 36
- upgrades, 83
- User Authentication message, 52
 - enabling, 53
- User Logon Name command, 104
- user names
 - adding, 44
 - entering, 39, 97
- User Password command, 104

V

- version, getting, 90, 91
- voltage, 128
- VT100 terminal
 - setting up, 65
- VT-100 terminal
 - connecting to, 35, 93

W

- Warm Start notification, 52
- water pipe ground, 30
- Web browser, 36
- Web Site, 37
 - authentication messages and, 52, 53
 - RadioLAN technical assistance, 131
- wildcards, 67
- Windows connections, 62
- wireless networks. *See* wireless stations
- wireless stations, 58, 66
 - bridging to hard-wired, 71, 118
 - getting performance information, 35, 81
 - identifying, 64
 - IP Address assignment and, 23
 - optimizing performance, 61, 76
 - protecting from unauthorized users, 35, 36
 - troubleshooting tips, 118
- Worst command, 116
- Write Community command, 107

Notes

RadioLAN

455 De Guigne Drive
Sunnyvale, CA 94086
Phone (408) 616-6300
Fax (408) 524-0600