



Specific Absorption Rate (SAR) Test Report

for

MiTAC Technology Corp.
on the
Notebook PC

Report No. : FA7N3014
Trade Name : MTC / GETAC
Model Name : E100 / E100N
FCC ID : MAUE02
Date of Testing : Dec. 20~21, 2007
Date of Report : Jan. 15, 2008
Date of Review : Jan. 15, 2008

- The test results refer exclusively to the presented test model/sample only.
- Without written approval of SPORTON International Inc., the test report shall not be reproduced except in full.
- Report Version: Rev. 01.

SPORTON International Inc.
6F, No.106, Sec. 1, Hsin Tai Wu Rd., Hsi Chih, Taipei Hsien, Taiwan, R.O.C.



Table of Contents

1.	Statement of Compliance	1
2.	Administration Data	2
2.1	Testing Laboratory	2
2.2	Detail of Applicant	2
2.3	Detail of Manufacturer	2
2.4	Application Detail	2
3	General Information	3
3.1	Description of Device Under Test (DUT)	3
3.2	Basic Description of Equipment under Test	4
3.3	Configuration of the Equipment	5
3.4	Product Photo	6
3.5	Applied Standards	7
3.6	Device Category and SAR Limits	8
3.7	Test Conditions:	8
3.6.1	Ambient Condition	8
3.6.2	Test Configuration	8
4	Specific Absorption Rate (SAR)	9
4.1	Introduction	9
4.2	SAR Definition	9
5	SAR Measurement Setup	10
5.1	DASY4 E-Field Probe System	11
5.1.1	ET3DV6 E-Field Probe Specification	12
5.1.2	ET3DV6 E-Field Probe Calibration	12
5.2	DATA Acquisition Electronics (DAE)	13
5.3	Robot	14
5.4	Measurement Server	14
5.5	SAM Twin Phantom	14
5.6	Device Holder for SAM Twin Phantom	16
5.7	Data Storage and Evaluation	17
5.7.1	Data Storage	17
5.7.2	Data Evaluation	17
5.8	Test Equipment List	20
6	Tissue Simulating Liquids	21
7	Uncertainty Assessment	23
8	SAR Measurement Evaluation	25
8.1	Purpose of System Performance Check	25
8.2	System Setup	25
8.3	Validation Results	27
9	Description for DUT Testing Position	28
10	Measurement Procedures	29
10.1	Spatial Peak SAR Evaluation	29
10.2	Scan Procedures	30
10.3	SAR Averaged Methods	30
11	SAR Test Results	31
11.1	Front Face with 0 cm Gap	31
11.2	Rear Face with 0 cm Gap	31
11.3	Top Side with 0 cm Gap	32
11.4	Bottom Side with 0 cm Gap	32
11.5	Right Side with 0 cm Gap	33
11.6	Left Side with 0 cm Gap	33
12	References	34

Appendix A - System Performance Check Data

Appendix B - SAR Measurement Data

Appendix C - Calibration Data

Appendix D - CDMA2000 Test Modes

Appendix E - Product Photo

Appendix F - Test Setup Photo



1. Statement of Compliance

The Specific Absorption Rate (SAR) maximum results found during testing for the **MiTAC Technology Corp. Notebook PC MTC / GETAC, E100 / E100N** are as follows (with expanded uncertainty 21.9%):

Model \ SAR	CDMA2000 Cellular (W/Kg)	CDMA2000 PCS (W/Kg)
E100N	1.49	1.16
E100	1.32	1.22

Remark: The largest summation of CDMA2000, Bluetooth and WLAN for body SAR is 1.518 W/kg and its position is Rear Face with 0 cm gap.

The co-location of CDMA2000, Bluetooth and WLAN were also checked. They are in compliance with Specific Absorption Rate (SAR) for general population/uncontrolled exposure limits specified in FCC 47 CFR part 2 (2.1093) and ANSI/IEEE C95.1-1999 and had been tested in accordance with the measurement methods and procedures specified in OET Bulletin 65 Supplement C (Edition 01-01).

Approved by

Roy Wu
Manager



2. Administration Data

2.1 Testing Laboratory

Company Name : Sporton International Inc.
Department : Antenna Design/SAR
Address : No.52, Hwa-Ya 1st RD., Hwa Ya Technology Park, Kwei-Shan Hsiang,
TaoYuan Hsien, Taiwan, R.O.C.
Telephone Number : 886-3-327-3456
Fax Number : 886-3-328-4978

2.2 Detail of Applicant

Company Name : MiTAC Technology Corp.
Address : 9th. FL., No.75, Ming Sheng E. Rd., Sec.3, Taipei, Taiwan

2.3 Detail of Manufacturer

Company Name : GeTAC Technology(Kunshan) LTD.
Address : No.269, 2nd Road, Export Processing Zone, Changjiang South Road,
Kunshan, Jiangsu, P.R.C

2.4 Application Detail

Date of reception of application: Nov. 30, 2007
Start of test : Dec. 20, 2007
End of test : Dec. 21, 2007

3 General Information

3.1 Description of Device Under Test (DUT)

Product Feature & Specification	
DUT Type :	Notebook PC
Trade Name :	MTC / GETAC
Model Name :	E100 / E100N
FCC ID :	MAUE02
Tx Frequency :	CDMA2000 Cellular : 824 ~ 849 MHz CDMA2000 PCS : 1850 ~ 1910 MHz Bluetooth / WLAN : 2400 ~ 2483.5 MHz
Rx Frequency :	CDMA2000 Cellular : 869 ~ 894 MHz CDMA2000 PCS : 1930 ~ 1990 MHz Bluetooth / WLAN : 2400 ~ 2483.5 MHz
Maximum Output Power :	<p>CDMA2000 Cellular (1xRTT): FCH_RC1 : 24.83 dBm FCH_RC3 : 24.85 dBm FCH+SCH_RC3 : 24.84 dBm</p> <p>CDMA2000 Cellular (1xEV-DO Rev.0_RTAP): 9.6Kbps : 23.95 dBm 38.4Kbps : 23.99 dBm 153.6Kbps : 24.06 dBm</p> <p>CDMA2000 Cellular (1xEV-DO Rev.A_RETAP): 128 : 23.90 dBm 2048 : 23.92 dBm 12288 : 23.84 dBm</p> <p>CDMA2000 PCS (1xRTT): FCH_RC1 : 25.48 dBm FCH_RC3 : 25.34 dBm FCH+SCH_RC3 : 25.46 dBm</p> <p>CDMA2000 PCS (1xEV-DO Rev.0_RTAP): 9.6Kbps : 24.73 dBm 38.4Kbps : 24.60 dBm 153.6Kbps : 24.61 dBm</p> <p>CDMA2000 PCS (1xEV-DO Rev.A_RETAP): 128 : 24.15 dBm 2048 : 23.94 dBm 12288 : 24.09 dBm</p> <p>WLAN: 802.11b: 16.56 dBm 802.11g: 13.56 dBm</p>
Antenna Type :	CDMA2000 : Retractable Antenna Bluetooth: PIFA Antenna WLAN: PIFA Antenna
HW Version :	R03
SW Version :	R102 (BIOS)
Type of Modulation :	CDMA2000: QPSK Bluetooth : GFSK

	WLAN : DSSS / OFDM
Power Rating (DC/AC , Voltage and Current of RF element or PA) :	DC 3V
DUT Stage :	Identical Prototype
Application Type :	Certification

3.2 Basic Description of Equipment under Test

Equipment	Notebook PC	
Trade Name	MTC / GETAC	
Model Name	E100 / E100N	
FCC ID	MAUE02	
AC Adapter	Brand Name	FSP
	Model Name	FSP050-1AD101C
	Power Rating	I/P:100-240Vac, 50-60Hz, 1.3A
	AC Power Cord Type	1.8 meter non-shielded cable without ferrite core
DC Adapter	Brand Name	FSP
	Model Name	FSP050-1AD101C
	Power Rating	O/P: 12Vdc, 4.16A, 50W MAX
	AC Power Cord Type	1.55 meter shielded cable with ferrite core
Battery	Brand Name	Sayno for E100N Panasonic for E100
	Model Name	UR18650F(M) for E100N CGR18650E for E100
	Power Rating	7.4Vdc, 5200mAh, 4cell
	Type	Li-ion

Remark:

1. E100 is almost the same as E100N. The differences between these models are panel and keyboard as follows:
 - a. Panel of E100 is 8.4 inch, and E100N is 8.9 inch.
 - b. E100N doesn't have the number key on the keyboard, but E100.
2. Above EUT's information was declared by manufacturer. Please refer to the specifications of manufacturer or User's Manual for more detailed features description.

3.3 Configuration of the Equipment

Model Name: E100N

Notebook Specification				
Item	Brand	Model	P/N	Specification
CPU	Intel Stealey	TDP 3W	---	800 MHz
LCD	Toshiba	Toshiba 8.9 inch TFT-LCD MODULE LTD089EXYM 1024x768	LTD089EXYM	8.9 inch TFT-LCD Module 1024x768
HDD	Toshiba	MK1011GAH	---	100 GB
Memory	Qimonda	HYS64T128021EDL-3S-B 2	---	DDR2 667 1GB
Adapter	FSP	PS050-1AD101C	---	---
Battery	Sayno	Sanyo UR18650F(M) (2.500/2600Mah)	---	DC 7.4V, Li-ION/ Sayno cell - 5200mAH/4cell,(P)
WLAN	Billionton, MiniCard (USB I/F)	GMEWLGRL	---	802.11b/g
Bluetooth	Billionton (USB I/F)	GUBTCR42M	---	V2.0 + EDR
GPS	GlobalSat	ET-312	---	RS232
3G	Novatel	E725	---	---

Model Name: E100

Notebook Specification				
Item	Brand	Model	P/N	Specification
CPU	Intel Stealey	TDP 3W	---	800 MHz
LCD	AUO 8.4" SVGA	G084SN02 V0 for digitizer option	G084SN02 V0	8.4 inch SVGA Color TFT LCD Module 800x600
HDD	Toshiba	MK6008GAH	---	60GB
Memory	HYNIX	HYMP512S64CP8-Y5	---	DDR2 667 1GB
Adapter	FSP	PS050-1AD101C	---	---
Battery	Panasonic	Panasonic CGR18650E 2.550AH	---	DC 7.4V, Li-ION/ Panasonic cell - 5200mAH/4cell, (P)
WLAN	Billionton, MiniCard (USB I/F)	GMEWLGRL	---	802.11b/g
Bluetooth	Billionton (USB I/F)	GUBTCR42M	---	V2.0 + EDR
GPS	GlobalSat	ET-312	---	RS232
3G	Novatel	E725	---	---



3.4 Product Photo

Please refer to Appendix E



3.5 Applied Standards

The Specific Absorption Rate (SAR) testing specification, method and procedure for this Notebook PC is in accordance with the following standards:

47 CFR Part 2 (2.1093),
IEEE C95.1-1999,
IEEE C95.3-2002,
IEEE P1528-2003, and
OET Bulletin 65 Supplement C (Edition 01-01)

3.6 Device Category and SAR Limits

This device belongs to portable device category because its radiating structure is allowed to be used within 20 centimeters of the body of the user.

Limit for General Population/Uncontrolled exposure should be applied for this device, it is 1.6 W/kg as averaged over any 1 gram of tissue.

3.7 Test Conditions:

3.6.1 Ambient Condition

Item	MSL_850	MSL_1900
Ambient Temperature (°C)	20-24	
Tissue simulating liquid temperature (°C)	21.2	21.6
Humidity (%)	<60 %	

3.6.2 Test Configuration

The device was controlled by using a base station emulator R&S CMU200. Communication between the device and the emulator was established by air link. The distance between the DUT and the antenna of the emulator is larger than 50 cm and the output power radiated from the emulator antenna is at least 30 dB smaller than the output power of DUT.

Measurements were performed on the lowest, middle, and highest channel for each testing position. However, if the SAR is below 3 dB of limit, measurements were performed only on the middle channel.

The DUT was set from the emulator to radiate maximum output power during all tests.

For body SAR testing, EUT is in CDMA2000 link mode, and its crest factor is 1.

4 Specific Absorption Rate (SAR)

4.1 Introduction

SAR is related to the rate at which energy is absorbed per unit mass in an object exposed to a radio field. The SAR distribution in a biological body is complicated and is usually carried out by experimental techniques or numerical modeling. The standard recommends limits for two tiers of groups, occupational/controlled and general population/uncontrolled, based on a person's awareness and ability to exercise control over his or her exposure. In general, occupational/controlled exposure limits are higher than the limits for general population/uncontrolled.

4.2 SAR Definition

The SAR definition is the time derivative (rate) of the incremental energy (dW) absorbed by (dissipated in) an incremental mass (dm) contained in a volume element (dv) of a given density (ρ). The equation description is as below:

$$\mathbf{SAR} = \frac{d}{dt} \left(\frac{dW}{dm} \right) = \frac{d}{dt} \left(\frac{dW}{\rho dv} \right)$$

SAR is expressed in units of Watts per kilogram (W/kg)

SAR measurement can be either related to the temperature elevation in tissue by

$$\mathbf{SAR} = C \frac{\delta T}{\delta t}$$

, where C is the specific heat capacity, δT is the temperature rise and δt the exposure duration,

or related to the electrical field in the tissue by

$$\mathbf{SAR} = \frac{\sigma |E|^2}{\rho}$$

, where σ is the conductivity of the tissue, ρ is the mass density of the tissue and E is the rms electrical field strength.

However for evaluating SAR of low power transmitter, electrical field measurement is typically applied.

5 SAR Measurement Setup

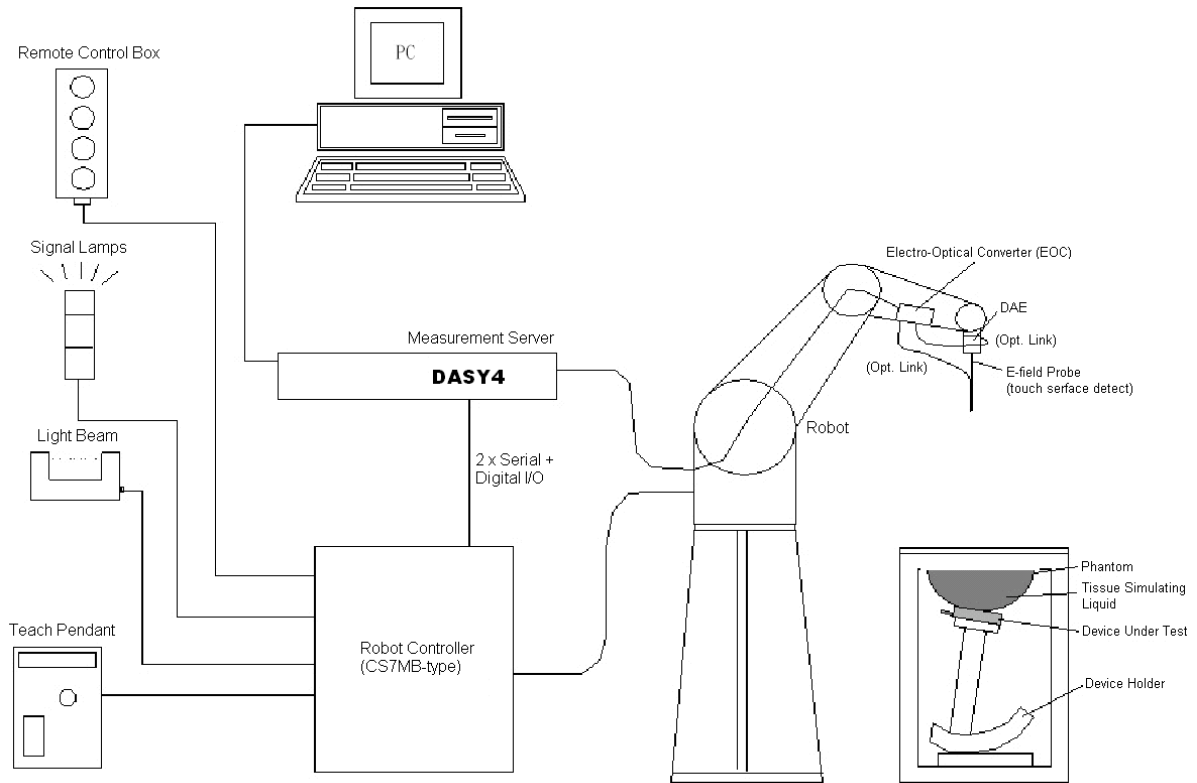

Fig. 5.1 DASY4 System

The DASY4 system for performance compliance tests is illustrated above graphically. This system consists of the following items:

- A standard high precision 6-axis robot with controller, a teach pendant and software
- A data acquisition electronic (DAE) attached to the robot arm extension
- A dosimetric probe equipped with an optical surface detector system
- The electro-optical converter (ECO) performs the conversion between optical and electrical signals
- A measurement server performs the time critical tasks such as signal filtering, control of the robot operation and fast movement interrupts.
- A probe alignment unit which improves the accuracy of the probe positioning
- A computer operating Windows XP
- DASY4 software
- Remote control with teach pendant and additional circuitry for robot safety such as warning lamps, etc.
- The SAM twin phantom
- A device holder
- Tissue simulating liquid
- Dipole for evaluating the proper functioning of the system

Some of the components are described in details in the following sub-sections.

5.1 DASY4 E-Field Probe System

The SAR measurement is conducted with the dosimetric probe ET3DV6 (manufactured by SPEAG). The probe is specially designed and calibrated for use in liquid with high permittivity. The dosimetric probe has special calibration in liquid at different frequency. This probe has a built in optical surface detection system to prevent from collision with phantom.

5.1.1 ET3DV6 E-Field Probe Specification

Construction	<p>Symmetrical design with triangular core</p> <p>Built-in optical fiber for surface detection system</p> <p>Built-in shielding against static charges</p> <p>PEEK enclosure material (resistant to organic solvents)</p>
Frequency	10 MHz to > 3 GHz
Directivity	<p>± 0.2 dB in brain tissue (rotation around probe axis)</p> <p>± 0.4 dB in brain tissue (rotation perpendicular to probe axis)</p>
Dynamic Range	5 μ W/g to > 100mW/g; Linearity: ±0.2dB
Surface Detection	± 0.2 mm repeatability in air and clear liquids on reflecting surface
Dimensions	<p>Overall length: 330mm</p> <p>Tip length: 16mm</p> <p>Body diameter: 12mm</p> <p>Tip diameter: 6.8mm</p> <p>Distance from probe tip to dipole centers: 2.7mm</p>
Application	<p>General dosimetry up to 3GHz</p> <p>Compliance tests for mobile phones and Wireless LAN</p> <p>Fast automatic scanning in arbitrary phantoms</p>



Fig. 5.2 Probe Setup on Robot

5.1.2 ET3DV6 E-Field Probe Calibration

Each probe needs to be calibrated according to a dosimetric assessment procedure with accuracy better than ± 10%. The spherical isotropy shall be evaluated and within ± 0.25dB. The sensitivity parameters (NormX, NormY, and NormZ), the diode compression parameter (DCP) and the conversion factor (ConvF) of the probe are tested. The calibration data are as below:

➤ **ET3DV6 sn1787**

Sensitivity	X axis : 1.63 μ V	Y axis : 1.66 μ V	Z axis : 2.08 μ V	
Diode compression point	X axis : 92 mV	Y axis : 96 mV	Z axis : 91 mV	
Conversion factor (Head / Body)	Frequency (MHz)	X axis	Y axis	Z axis
	800~1000	6.58 / 6.10	6.58 / 6.10	6.58 / 6.10
	1710~1910	5.16 / 4.68	5.16 / 4.68	5.16 / 4.68
Boundary effect (Head / Body)	Frequency (MHz)	Alpha	Depth	
	800~1000	0.32 / 0.36	2.42 / 2.52	
	1710~1910	0.50 / 0.61	2.61 / 2.56	

NOTE: The probe parameters have been calibrated by the SPEAG.

5.2 DATA Acquisition Electronics (DAE)

The data acquisition electronics (DAE4) consists of a highly sensitive electrometer-grade preamplifier with auto-zeroing, a channel and gain-switching multiplexer, a fast 16 bit AD-converter and a command decoder and control logic unit. Transmission to the measurement server is accomplished through an optical downlink for data and status information as well as an optical uplink for commands and the clock.

The mechanical probe mounting device includes two different sensor systems for frontal and sideways probe contacts. They are used for mechanical surface detection and probe collision detection.

The input impedance of the DAE4 is 200M Ohm; the inputs are symmetrical and floating. Common mode rejection is above 80dB.

5.3 Robot

The DASY4 system uses the high precision robots RX90BL type out of the newer series from Stäubli SA (France). For the 6-axis controller DASY4 system, the CS7MB robot controller version from Stäubli is used. The RX robot series have many features that are important for our application:

- High precision (repeatability 0.02 mm)
- High reliability (industrial design)
- Jerk-free straight movements
- Low ELF interference (the closed metallic construction shields against motor control fields)
- 6-axis controller

5.4 Measurement Server

The DASY4 measurement server is based on a PC/104 CPU board with
166 MHz CPU
32 MB chipset and
64 MB RAM.

Communication with
the DAE4 electronic box
the 16-bit AD-converter system for optical detection and digital I/O interface.

The measurement server performs all the real-time data evaluation for field measurements and surface detection, controls robot movements and handles safety operations.

5.5 SAM Twin Phantom

The SAM twin phantom is a fiberglass shell phantom with 2mm shell thickness (except the ear region where shell thickness increases to 6mm). It has three measurement areas:

- Left head
- Right head
- Flat phantom

The bottom plate contains three pair of bolts for locking the device holder. The device holder positions are adjusted to the standard measurement positions in the three sections.

A white cover is provided to tap the phantom during off-periods to prevent water evaporation and changes in the liquid parameters.

On the phantom top, three reference markers are provided to identify the phantom position with respect to the robot.

The phantom can be used with the following tissue simulating liquids:

- *Water-sugar based liquid
- *Glycol based liquids



Fig. 5.3 Top View of Twin Phantom



Fig. 5.4 Bottom View of Twin Phantom

5.6 Device Holder for SAM Twin Phantom

The SAR in the Phantom is approximately inversely proportional to the square of the distance between the source and the liquid surface. For a source in 5 mm distance, a positioning uncertainty of $\pm 0.5\text{mm}$ would produce a SAR uncertainty of $\pm 20\%$. An accurate device position is therefore crucial for accurate and repeatable measurement. The position in which the devices must be measured, are defined by the standards.

The DASY4 device holder is designed to cope with different positions given in the standard. It has two scales for the device rotation (with respect to the body axis) and the device inclination (with respect to the line between the ear reference points). The rotation center for both scales is the ear reference point (EPR).

Thus the device needs no repositioning when changing the angles.

The DASY4 device holder has been made out of low-loss POM material having the following dielectric parameters: relative permittivity $\epsilon_r = 3$ and loss tangent $\delta = 0.02$. The amount of dielectric material has been reduced in the closest vicinity of the device, since measurements have suggested that the influence of the clamp on the test results could thus be lowered.



Fig. 5.5 Device Holder

5.7 Data Storage and Evaluation

5.7.1 Data Storage

The DASY4 software stores the assessed data from the data acquisition electronics as raw data (in microvolt readings from the probe sensors), together with all the necessary software parameters for the data evaluation (probe calibration data, liquid parameters and device frequency and modulation data) in measurement files with the extension .DA4. The post-processing software evaluates the desired unit and format for output each time the data is visualized or exported. This allows verification of the complete software setup even after the measurement and allows correction of erroneous parameter settings. For example, if a measurement has been performed with an incorrect crest factor parameter in the device setup, the parameter can be corrected afterwards and the data can be reevaluated.

The measured data can be visualized or exported in different units or formats, depending on the selected probe type (e.g., [V/m], [A/m], [mW/g]). Some of these units are not available in certain situations or give meaningless results, e.g., a SAR-output in a non-lose media, will always be zero. Raw data can also be exported to perform the evaluation with other software packages.

5.7.2 Data Evaluation

The DASY4 post-processing software (SEMCAD) automatically executes the following procedures to calculate the field units from the microvolt readings at the probe connector. The parameters used in the evaluation are stored in the configuration modules of the software :

Probe parameters :	- Sensitivity	Norm _i , a _{i0} , a _{i1} , a _{i2}
	- Conversion factor	ConvF _i
	- Diode compression point	dcp _i
Device parameters :	- Frequency	f
	- Crest factor	cf
Media parameters :	- Conductivity	
	- Density	

These parameters must be set correctly in the software. They can be found in the component documents or they can be imported into the software from the configuration files issued for the DASY components. In the direct measuring mode of the multi-meter option, the parameters of the actual system setup are used. In the scan visualization and export modes, the parameters stored in the corresponding document files are used.

The first step of the evaluation is a linearization of the filtered input signal to account for the compression characteristics of the detector diode. The compensation depends on the input signal, the diode type and the DC-transmission factor from the diode to the evaluation electronics. If the exciting field is pulsed, the crest factor of the signal must be known to correctly compensate for peak power. The formula for each channel can be given as :

$$V_i = U_i + U_i^2 \cdot \frac{cf}{dcp_i}$$

with $V_i =$ compensated signal of channel i ($i = x, y, z$)
 $U_i =$ input signal of channel i ($i = x, y, z$)
 $cf =$ crest factor of exciting field (DASY parameter)
 $dcp_i =$ diode compression point (DASY parameter)

From the compensated input signals, the primary field data for each channel can be evaluated :

$$\text{E-field probes : } E_i = \sqrt{\frac{V_i}{Norm_i ConvF}}$$

$$\text{H-field probes : } H_i = \sqrt{V_i \frac{a_{i0} + a_{i1}f + a_{i2}f^2}{f}}$$

with $V_i =$ compensated signal of channel i ($i = x, y, z$)
 $Norm_i =$ sensor sensitivity of channel i ($i = x, y, z$)
 $\mu V/(V/m)^2$ for E-field Probes
 $ConvF =$ sensitivity enhancement in solution
 $a_{ij} =$ sensor sensitivity factors for H-field probes
 $f =$ carrier frequency [GHz]
 $E_i =$ electric field strength of channel i in V/m
 $H_i =$ magnetic field strength of channel i in A/m

The RSS value of the field components gives the total field strength (Hermitian magnitude) :

$$E_{tot} = \sqrt{E_x^2 + E_y^2 + E_z^2}$$

The primary field data are used to calculate the derived field units.

$$SAR = E_{tot}^2 \cdot \frac{\sigma}{\rho \cdot 1000}$$

with $SAR =$ local specific absorption rate in mW/g
 $E_{tot} =$ total field strength in V/m
 $=$ conductivity in [mho/m] or [Siemens/m]
 $=$ equivalent tissue density in g/cm^3

* Note that the density is set to 1, to account for actual head tissue density rather than the density of the tissue simulating liquid.

The power flow density is calculated assuming the excitation field to be a free space field.



$$P_{pwe} = \frac{E_{tot}^2}{3770} \quad \text{or} \quad P_{pwe} = H_{tot}^2 \cdot 37.7$$

with P_{pwe} = equivalent power density of a plane wave in mW/cm²
 E_{tot} = total electric field strength in V/m
 H_{tot} = total magnetic field strength in A/m

5.8 Test Equipment List

Manufacture	Name of Equipment	Type/Model	Serial Number	Calibration	
				Last Cal.	Due Date
SPEAG	Dosimetric E-Filed Probe	ET3DV6	1787	Aug. 28, 2007	Aug. 28, 2008
SPEAG	835MHz System Validation Kit	D835V2	499	Mar. 15, 2006	Mar. 15, 2008
SPEAG	1900MHz System Validation Kit	D1900V2	5d041	Mar. 21, 2006	Mar. 21, 2008
SPEAG	Data Acquisition Electronics	DAE4	778	Sep. 17, 2007	Sep. 17, 2008
SPEAG	Device Holder	N/A	N/A	NCR	NCR
SPEAG	Phantom	QD 000 P40 C	TP-1303	NCR	NCR
SPEAG	Phantom	QD 000 P40 C	TP-1383	NCR	NCR
SPEAG	Phantom	QD 0VA 001 BB	1029	NCR	NCR
SPEAG	Robot	Staubli RX90BL	F03/5W15A1/A/01	NCR	NCR
SPEAG	Software	DASY4 V4.7 Build 55	N/A	NCR	NCR
SPEAG	Software	SEMCAD V1.8 Build 176	N/A	NCR	NCR
SPEAG	Measurement Server	SE UMS 001 BA	1021	NCR	NCR
Agilent	ENA Series Network Analyzer	E5071C	MY46100746	Feb. 21, 2007	Feb. 21, 2008
Agilent	Wireless Communication Test Set	E5515C	GB46311322	Dec. 22, 2006	Dec. 22, 2008
Agilent	Dielectric Probe Kit	85070D	US01440205	NCR	NCR
Agilent	Dual Directional Coupler	778D	50422	NCR	NCR
Agilent	Power Amplifier	8449B	3008A01917	NCR	NCR
Agilent	Power Meter	E4416A	GB41292344	Feb. 08, 2007	Feb. 08, 2008
Agilent	Power Sensor	E9327A	US40441548	Feb. 08, 2007	Feb. 08, 2008
Agilent	Signal Generator	E8247C	MY43320596	Mar. 01, 2006	Mar. 01, 2008

Table 5.1 Test Equipment List

6 Tissue Simulating Liquids

For the measurement of the field distribution inside the SAM phantom with DASY4, the phantom must be filled with around 25 liters of homogeneous tissue simulating liquid. The liquid height from the ear reference point (ERP) of the phantom to the liquid top surface is (head SAR) or from the flat phantom to the liquid top surface (body SAR) is 15.2cm.

The following ingredients for tissue simulating liquid are used:

- **Water:** deionized water (pure H₂O), resistivity 16M - as basis for the liquid
- **Sugar:** refined sugar in crystals, as available in food shops – to reduce relative permittivity
- **Salt:** pure NaCl – to increase conductivity
- **Cellulose:** Hydroxyethyl-cellulose, medium viscosity (75-125 mPa.s, 2% in water, 20°C), CAS#54290-to increase viscosity and to keep sugar in solution.
- **Preservative:** Preventol D-7 Bayer AG, D-51368 Leverkusen, CAS#55965-84-9- to prevent the spread of bacteria and molds.
- **DGMBE:** Deithlenglycol-monobuthyl ether (DGMBE), Fluka Chemie GmbH, CAS#112-34-5 – to reduce relative permittivity.

Table 6.1 gives the recipes for one liter of head and body tissue simulating liquid for frequency band 850 MHz and 1900 MHz.

Ingredient	MSL-850	MSL-1900
Water	631.68 g	716.56 g
Cellulose	0 g	0 g
Salt	11.72 g	4.0 g
Preventol D-7	1.2 g	0 g
Sugar	600.0 g	0 g
DGMBE	0 g	300.67 g
Total amount	1 liter (1.3 kg)	1 liter (1.0 kg)
Dielectric Parameters at 22°	f=835 MHz $\epsilon_r = 55.2 \pm 5\%$, $\sigma = 0.97 \pm 5\%$ S/m	f= 1900 MHz $\epsilon_r = 53.3 \pm 5\%$, $\sigma = 1.52 \pm 5\%$ S/m

Table 6.1 Recipes for Tissue Simulating Liquid

The dielectric parameters of the liquids were verified prior to the SAR evaluation using an Agilent 85070D Dielectric Probe Kit and an Agilent Network Analyzer.

Table 6.2 shows the measuring results for muscle simulating liquid.

Bands	Frequency (MHz)	Permittivity (ϵ_r)	Conductivity (σ)	Measurement Date
CDMA2000 Cellular 850	824.70	55.3	0.959	Dec. 20, 2007
	836.52	55.1	0.971	
	848.31	55.0	0.983	
CDMA2000 PCS 1900	1851.25	51.9	1.51	Dec. 20, 2007
	1880.00	51.8	1.54	
	1908.75	51.8	1.57	

Table 6.2 Measuring Results for Simulating Liquid

The measuring data are consistent with $\epsilon_r = 55.2 \pm 5\%$ and $\sigma = 0.97 \pm 5\%$ for body Cellular band and $\epsilon_r = 53.3 \pm 5\%$ and $\sigma = 1.52 \pm 5\%$ for body PCS band.

7 Uncertainty Assessment

The component of uncertainty may generally be categorized according to the methods used to evaluate them. The evaluation of uncertainty by the statistical analysis of a series of observations is termed a Type A evaluation of uncertainty. The evaluation of uncertainty by means other than the statistical analysis of a series of observation is termed a Type B evaluation of uncertainty. Each component of uncertainty, however evaluated, is represented by an estimated standard deviation, termed standard uncertainty, which is determined by the positive square root of the estimated variance.

A Type A evaluation of standard uncertainty may be based on any valid statistical method for treating data. This includes calculating the standard deviation of the mean of a series of independent observations; using the method of least squares to fit a curve to the data in order to estimate the parameter of the curve and their standard deviations; or carrying out an analysis of variance in order to identify and quantify random effects in certain kinds of measurement.

A type B evaluation of standard uncertainty is typically based on scientific judgment using all of the relevant information available. These may include previous measurement data, experience and knowledge of the behavior and properties of relevant materials and instruments, manufacture’s specification, data provided in calibration reports and uncertainties assigned to reference data taken from handbooks. Broadly speaking, the uncertainty is either obtained from an outdoor source or obtained from an assumed distribution, such as the normal distribution, rectangular or triangular distributions indicated in Table 6.1

Uncertainty Distributions	Normal	Rectangular	Triangular	U-shape
Multiplying factor ^(a)	1/k ^(b)	1/ 3	1/ 6	1/ 2

(a) standard uncertainty is determined as the product of the multiplying factor and the estimated range of variations in the measured quantity

(b) is the coverage factor

Table 7.1 Multiplying Factions for Various Distributions

The combined standard uncertainty of the measurement result represents the estimated standard deviation of the result. It is obtained by combining the individual standard uncertainties of both Type A and Type B evaluation using the usual “root-sum-squares” (RSS) methods of combining standard deviations by taking the positive square root of the estimated variances.

Expanded uncertainty is a measure of uncertainty that defines an interval about the measurement result within which the measured value is confidently believed to lie. It is obtained by multiplying the combined standard uncertainty by a coverage factor. Typically, the coverage factor ranges from 2 to 3. Using a coverage factor allows the true value of a measured quantity to be specified with a defined probability within the specified uncertainty range. For purpose of this document, a coverage factor two is used, which corresponds to confidence interval of about 95 %. The DAS4 uncertainty Budget is showed in Table 7.2.



Error Description	Uncertainty Value ± %	Probability Distribution	Divisor	Ci (1g)	Standard Unc. (1g)	vi or Veff
Measurement Equipment						
Probe Calibration	±5.9 %	Normal	1	1	±5.9 %	∞
Axial Isotropy	±4.7 %	Rectangular	√3	0.7	±1.9 %	∞
Hemispherical Isotropy	±9.6 %	Rectangular	√3	0.7	±3.9 %	∞
Boundary Effects	±1.0 %	Rectangular	√3	1	±0.6 %	∞
Linearity	±4.7 %	Rectangular	√3	1	±2.7 %	∞
System Detection Limits	±1.0 %	Rectangular	√3	1	±0.6 %	∞
Readout Electronics	±0.3 %	Normal	1	1	±0.3 %	∞
Response Time	±0.8 %	Rectangular	√3	1	±0.5 %	∞
Integration Time	±2.6 %	Rectangular	√3	1	±1.5 %	∞
RF Ambient Noise	±3.0 %	Rectangular	√3	1	±1.7 %	∞
RF Ambient Reflections	±3.0 %	Rectangular	√3	1	±1.7 %	∞
Probe Positioner	±0.4 %	Rectangular	√3	1	±0.2 %	∞
Probe Positioning	±2.9 %	Rectangular	√3	1	±1.7 %	∞
Max. SAR Eval.	±1.0 %	Rectangular	√3	1	±0.6 %	∞
Test Sample Related						
Device Positioning	±2.9 %	Normal	1	1	±2.9	145
Device Holder	±3.6 %	Normal	1	1	±3.6	5
Power Drift	±5.0 %	Rectangular	√3	1	±2.9	∞
Phantom and Setup						
Phantom Uncertainty	±4.0 %	Rectangular	√3	1	±2.3	∞
Liquid Conductivity (target)	±5.0 %	Rectangular	√3	0.64	±1.8	∞
Liquid Conductivity (meas.)	±2.5 %	Normal	1	0.64	±1.6	∞
Liquid Permittivity (target)	±5.0 %	Rectangular	√3	0.6	±1.7	∞
Liquid Permittivity (meas.)	±2.5 %	Normal	1	0.6	±1.5	∞
Combined Standard Uncertainty					±10.9	387
Coverage Factor for 95 %		K=2				
Expanded uncertainty (Coverage factor = 2)					±21.9	

Table 7.2 Uncertainty Budget of DASY4

8 SAR Measurement Evaluation

Each DASY4 system is equipped with one or more system validation kits. These units, together with the predefined measurement procedures within the DASY4 software, enable the user to conduct the system performance check and system validation. System validation kit includes a dipole, tripod holder to fix it underneath the flat phantom and a corresponding distance holder.

8.1 Purpose of System Performance Check

The system performance check verifies that the system operates within its specifications. System and operator errors can be detected and corrected. It is recommended that the system performance check be performed prior to any usage of the system in order to guarantee reproducible results. The system performance check uses normal SAR measurements in a simplified setup with a well characterized source. This setup was selected to give a high sensitivity to all parameters that might fail or vary over time. The system check does not intend to replace the calibration of the components, but indicates situations where the system uncertainty is exceeded due to drift or failure.

8.2 System Setup

In the simplified setup for system evaluation, the DUT is replaced by a calibrated dipole and the power source is replaced by a continuous wave that comes from a signal generator at frequency 835 MHz and 1900 MHz. The calibrated dipole must be placed beneath the flat phantom section of the SAM twin phantom with the correct distance holder. The distance holder should touch the phantom surface with a light pressure at the reference marking and be oriented parallel to the long side of the phantom. The equipment setup is shown below:

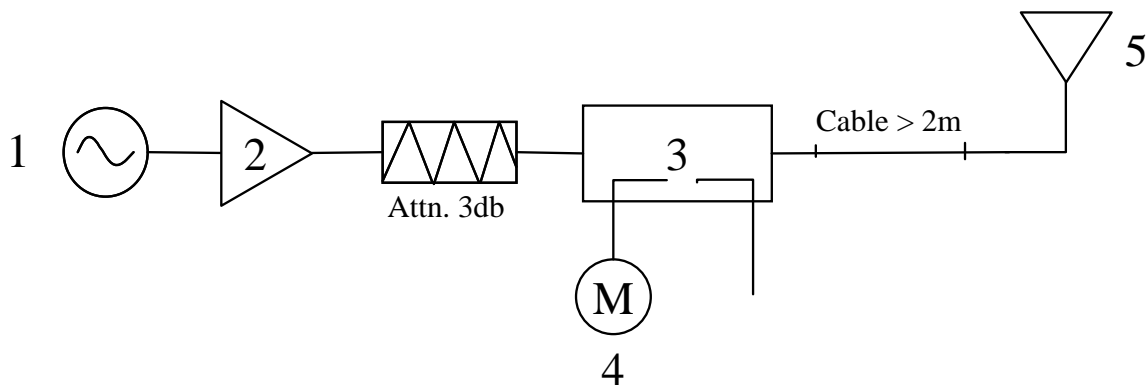

Fig. 8.1 System Setup for System Evaluation

1. Signal Generator
2. Amplifier
3. Directional Coupler
4. Power Meter
5. 835 MHz or 1900 MHz Dipole

The output power on dipole port must be calibrated to 20dBm (100mW) before dipole is connected.



Fig 8.2 Dipole Setup

8.3 Validation Results

Comparing to the original SAR value provided by SPEAG, the validation data should be within its specification of 10 %. Table 8.1 shows the target SAR and measured SAR after normalized to 1W input power.

Band	SAR	Target (W/kg)	Measurement data (W/kg)	Variation	Measurement Date
CDMA2000 Cellular 850 (835 MHz)	SAR (1g)	9.91	10.2	2.9 %	Dec. 20, 2007
	SAR (10g)	6.55	6.82	4.1 %	
CDMA2000 PCS 1900 (1900 MHz)	SAR (1g)	41.1	41.4	0.7 %	Dec. 21, 2007
	SAR (10g)	21.8	22.0	0.9 %	

Table 8.1 Target and Measurement Data Comparison

The table above indicates the system performance check can meet the variation criterion.



9 Description for DUT Testing Position

This DUT was tested in 6 different positions. Besides, antenna on the DUT was tested in two states of each position.

They are “Front face with 0 cm Gap with Ant-Retract”, “Front face with 0 cm Gap with Ant-Extend”, “Rear face with 0 cm Gap Ant-Retract”, “Rear face with 0 cm Gap Ant-Extend”, “Top Side with 0 cm Gap with Ant-Retract”, “Top Side with 0 cm Gap with Ant-Extend”, “Bottom Side with 0 cm Gap with Ant-Retract”, “Bottom Side with 0 cm Gap with Ant-Extend”, “Right Side with 0 cm Gap with Ant-Retract”, “Right Side with 0 cm Gap with Ant-Extend”, “Left Side with 0 cm Gap with Ant-Retract”, and “Left Side with 0 cm Gap with Ant-Extend”.

Remark: Please refer to Appendix F for the test setup photo.

10 Measurement Procedures

The measurement procedures are as follows:

- Linking DUT with base station emulator CMU200 in middle channel for Cellular 850 and PCS 1900 band
- Setting CMU200 to allow DUT to radiate maximum output power
- Measuring output power through RF cable and power meter
- Placing the DUT in the positions described in the last section
- Setting scan area, grid size and other setting on the DASY4 software
- Taking data for the lowest, middle, and highest channel on each testing position

According to the IEEE P1528 draft standard, the recommended procedure for assessing the peak spatial-average SAR value consists of the following steps:

- Power reference measurement
- Area scan
- Zoom scan
- Power reference measurement

10.1 Spatial Peak SAR Evaluation

The procedure for spatial peak SAR evaluation has been implemented according to the IEEE1528-2003 standard. It can be conducted for 1g and 10g, as well as for user-specific masses. The DASY4 software includes all numerical procedures necessary to evaluate the spatial peak SAR value.

Base on the Draft: SCC-34, SC-2, WG-2-Computational Dosimetry, IEEE P1528/D1.2 (Recommended Practice for Determining the Peak Spatial-Average Specific Absorption Rate (SAR) in the Human Head from Wireless Communications Devices: Measurement Techniques), a new algorithm has been implemented. The spatial-peak SAR can be computed over any required mass.

The base for the evaluation is a "cube" measurement. The measured volume must include the 1g and 10g cubes with the highest averaged SAR values. For that purpose, the center of the measured volume is aligned to the interpolated peak SAR value of a previously performed area scan.

The entire evaluation of the spatial peak values is performed within the post-processing engine (SEMCAD). The system always gives the maximum values for the 1g and 10g cubes. The algorithm to find the cube with highest averaged SAR is divided into the following stages:

- extraction of the measured data (grid and values) from the Zoom Scan
- calculation of the SAR value at every measurement point based on all stored data (A/D values and measurement parameters)
- generation of a high-resolution mesh within the measured volume

- interpolation of all measured values from the measurement grid to the high-resolution grid
- extrapolation of the entire 3-D field distribution to the phantom surface over the distance from sensor to surface
- calculation of the averaged SAR within masses of 1g and 10g

10.2 Scan Procedures

First Area Scan is used to locate the approximate location(s) of the local peak SAR value(s). The measurement grid within an Area Scan is defined by the grid extent, grid step size and grid offset. Next, in order to determine the EM field distribution in a three-dimensional spatial extension, Zoom Scan is required. The Zoom Scan measures 5x5x7 points with step size 8, 8 and 5 mm. The Zoom Scan is performed around the highest E-field value to determine the averaged SAR-distribution over 1 g.

10.3 SAR Averaged Methods

In DASy4, the interpolation and extrapolation are both based on the modified Quadratic Shepard's method. The interpolation scheme combines a least-square fitted function method and a weighted average method which are the two basic types of computational interpolation and approximation.

Extrapolation routines are used to obtain SAR values between the lowest measurement points and the inner phantom surface. The extrapolation distance is determined by the surface detection distance and the probe sensor offset. The uncertainty increases with the extrapolation distance. To keep the uncertainty within 1% for the 1 g and 10 g cubes, the extrapolation distance should not be larger than 5 mm.

11 SAR Test Results

11.1 Front Face with 0 cm Gap

Model	Ant. State	Band	Mode	Chan.	Freq. (MHz)	Modulation Type	Conducted Power (dBm)	Power Drift (dB)	Measured 1g SAR (W/kg)	Limit (W/kg)	Results
E100N	Retract	CDMA2000 Cellular	FCH_RC1	384	836.52	QPSK	24.47	0.166	0.00188	1.6	Pass
		CDMA2000 PCS	FCH_RC1	600	1880.00	QPSK	24.80	-0.187	0.00507	1.6	Pass
	Extend	CDMA2000 Cellular	FCH_RC1	384	836.52	QPSK	24.47	-0.14	0.772	1.6	Pass
		CDMA2000 PCS	FCH_RC1	600	1880.00	QPSK	24.80	-0.642	0.168	1.6	Pass

11.2 Rear Face with 0 cm Gap

Model	Ant. State	Band	Mode	Chan.	Freq. (MHz)	Modulation Type	Conducted Power (dBm)	Power Drift (dB)	Measured 1g SAR (W/kg)	Limit (W/kg)	Results		
E100N	Retract	CDMA2000 Cellular	FCH_RC1	1013	824.70	QPSK	24.83	-	-	-	-		
				384	836.52	QPSK	24.47	0.197	0.0000888	1.6	Pass		
				777	848.31	QPSK	24.72	-	-	-	-		
		CDMA2000 PCS	FCH_RC1	25	1851.25	QPSK	25.48	-	-	-	-		
				600	1880.00	QPSK	24.80	-0.111	0.00911	1.6	Pass		
				1175	1908.75	QPSK	24.62	-	-	-	-		
	Extend	CDMA2000 Cellular	FCH_RC1	FCH_RC1	1013	824.70	QPSK	24.83	0.111	1.49	1.6	Pass	
					384	836.52	QPSK	24.47	-0.093	1.35	1.6	Pass	
					777	848.31	QPSK	24.72	0.041	1.45	1.6	Pass	
				FCH_RC1 with Bluetooth On	1013	824.70	QPSK	24.83	0.064	1.44	1.6	Pass	
					FCH_RC3	1013	824.70	QPSK	24.85	-0.06	1.25	1.6	Pass
						384	836.52	QPSK	24.33	-0.014	1.32	1.6	Pass
				777		848.31	QPSK	24.74	0.133	1.25	1.6	Pass	
				FCH+SCH_RC3	1013	824.70	QPSK	24.84	0.018	1.23	1.6	Pass	
					384	836.52	QPSK	24.27	0.045	1.31	1.6	Pass	
			777		848.31	QPSK	24.73	0.024	1.25	1.6	Pass		
			1xEVDO Rev0 RTAP 9.6K	1013	824.70	QPSK	23.94	0.018	1.23	1.6	Pass		
				384	836.52	QPSK	23.95	0.018	1.04	1.6	Pass		
				777	848.31	QPSK	23.75	0.024	1.25	1.6	Pass		
			1xEVDO Rev0 RTAP 38.4K	1013	824.70	QPSK	23.99	-	-	-	-		
				384	836.52	QPSK	23.98	0.144	1.06	1.6	Pass		
				777	848.31	QPSK	23.86	-	-	-	-		
			1xEVDO Rev0 RTAP 153.6K	1013	824.70	QPSK	24.06	-	-	-	-		
				384	836.52	QPSK	24.04	0.025	1.15	1.6	Pass		
				777	848.31	QPSK	23.97	-	-	-	-		
			1xEVDO RevA RETAP 128	1013	824.70	QPSK	23.90	-	-	-	-		
				384	836.52	QPSK	23.90	0.077	1.09	1.6	Pass		
				777	848.31	QPSK	23.68	-	-	-	-		
			1xEVDO RevA RETAP 2048	1013	824.70	QPSK	23.92	-	-	-	-		
				384	836.52	QPSK	23.88	0.095	1.1	1.6	Pass		
				777	848.31	QPSK	23.80	-	-	-	-		
			1xEVDO RevA RETAP 12288	1013	824.70	QPSK	23.82	-	-	-	-		
				384	836.52	QPSK	23.84	0.021	1.08	1.6	Pass		
777	848.31	QPSK		23.66	-	-	-	-					

E100N	Extend	CDMA2000 PCS	FCH_RC1	25	1851.25	QPSK	25.48	0.099	1.16	1.6	Pass	
				600	1880.00	QPSK	24.80	-0.145	1.16	1.6	Pass	
				1175	1908.75	QPSK	24.62	-0.141	0.584	1.6	Pass	
			FCH_RC1 with Bluetooth On	600	1880.00	QPSK	24.80	-0.089	1.07	1.6	Pass	
				FCH_RC3	25	1851.25	QPSK	25.34	0.129	0.871	1.6	Pass
					600	1880.00	QPSK	24.76	-0.108	1.1	1.6	Pass
			FCH+SCH_RC3	1175	1908.75	QPSK	24.54	0.149	0.467	1.6	Pass	
				25	1851.25	QPSK	25.46	-	-	-	-	
				600	1880.00	QPSK	24.85	-0.178	1.09	1.6	Pass	
			1xEVDO Rev0 RTAP 9.6K	1175	1908.75	QPSK	24.66	-	-	-	-	
				25	1851.25	QPSK	24.73	-0.171	0.987	1.6	Pass	
				600	1880.00	QPSK	24.10	-0.168	1.11	1.6	Pass	
			1xEVDO Rev0 RTAP 38.4K	1175	1908.75	QPSK	23.53	-0.154	0.506	1.6	Pass	
				25	1851.25	QPSK	24.60	-	-	-	-	
				600	1880.00	QPSK	24.03	0.127	1.07	1.6	Pass	
			1xEVDO Rev0 RTAP 153.6K	1175	1908.75	QPSK	23.67	-	-	-	-	
				25	1851.25	QPSK	24.61	-	-	-	-	
				600	1880.00	QPSK	24.16	0.184	0.994	1.6	Pass	
			1xEVDO RevA RETAP 128	1175	1908.75	QPSK	23.84	-	-	-	-	
				25	1851.25	QPSK	24.15	-	-	-	-	
				600	1880.00	QPSK	23.48	0.181	1.06	1.6	Pass	
1xEVDO RevA RETAP 2048	1175	1908.75	QPSK	22.94	-	-	-	-				
	25	1851.25	QPSK	23.94	-	-	-	-				
	600	1880.00	QPSK	23.52	-0.131	1.03	1.6	Pass				
1xEVDO RevA RETAP 12288	1175	1908.75	QPSK	23.02	-	-	-	-				
	25	1851.25	QPSK	24.09	-	-	-	-				
	600	1880.00	QPSK	23.47	0.179	1.02	1.6	Pass				
E100	Extend	CDMA2000 Cellular	FCH_RC1	1013	824.70	QPSK	24.83	0.145	1.32	1.6	Pass	
				384	836.52	QPSK	24.47	-	-	-	-	
				777	848.31	QPSK	24.72	-	-	-	-	
		CDMA2000 PCS	FCH_RC1	25	1851.25	QPSK	25.48	-	-	-	-	
				600	1880.00	QPSK	24.80	0.142	1.22	1.6	Pass	
				1175	1908.75	QPSK	24.62	-	-	-	-	
				1175	1908.75	QPSK	24.62	-	-	-	-	

11.3 Top Side with 0 cm Gap

Model	Ant. State	Band	Mode	Chan.	Freq. (MHz)	Modulation Type	Conducted Power (dBm)	Power Drift (dB)	Measured 1g SAR (W/kg)	Limit (W/kg)	Results
E100N	Retract	CDMA2000 Cellular	FCH_RC1	384	836.52	QPSK	24.47	0.116	0.0003	1.6	Pass
		CDMA2000 PCS	FCH_RC1	600	1880.00	QPSK	24.80	-0.121	0.026	1.6	Pass

11.4 Bottom Side with 0 cm Gap

Model	Ant. State	Band	Mode	Chan.	Freq. (MHz)	Modulation Type	Conducted Power (dBm)	Power Drift (dB)	Measured 1g SAR (W/kg)	Limit (W/kg)	Results
E100N	Retract	CDMA2000 Cellular	FCH_RC1	384	836.52	QPSK	24.47	-0.125	0.000039	1.6	Pass
		CDMA2000 PCS	FCH_RC1	600	1880.00	QPSK	24.80	0.107	0.000018	1.6	Pass
	Extend	CDMA2000 Cellular	FCH_RC1	384	836.52	QPSK	24.47	0.104	0.046	1.6	Pass
		CDMA2000 PCS	FCH_RC1	600	1880.00	QPSK	24.80	0.199	0.045	1.6	Pass

11.5 Right Side with 0 cm Gap

Model	Ant. State	Band	Mode	Chan.	Freq. (MHz)	Modulation Type	Conducted Power (dBm)	Power Drift (dB)	Measured 1g SAR (W/kg)	Limit (W/kg)	Results
E100N	Retract	CDMA2000 Cellular	FCH_RC1	384	836.52	QPSK	24.47	-0.155	0.00000383	1.6	Pass
		CDMA2000 PCS	FCH_RC1	600	1880.00	QPSK	24.80	0.164	0.000989	1.6	Pass
	Extend	CDMA2000 Cellular	FCH_RC1	384	836.52	QPSK	24.47	0.093	0.038	1.6	Pass
		CDMA2000 PCS	FCH_RC1	600	1880.00	QPSK	24.80	0.15	0.031	1.6	Pass

11.6 Left Side with 0 cm Gap

Model	Ant. State	Band	Mode	Chan.	Freq. (MHz)	Modulation Type	Conducted Power (dBm)	Power Drift (dB)	Measured 1g SAR (W/kg)	Limit (W/kg)	Results
E100N	Retract	CDMA2000 Cellular	FCH_RC1	384	836.52	QPSK	24.47	-0.175	0.00211	1.6	Pass
		CDMA2000 PCS	FCH_RC1	600	1880.00	QPSK	24.80	-0.158	0.00486	1.6	Pass
	Extend	CDMA2000 Cellular	FCH_RC1	384	836.52	QPSK	24.47	0.052	0.544	1.6	Pass
		CDMA2000 PCS	FCH_RC1	600	1880.00	QPSK	24.80	-0.182	0.164	1.6	Pass

Remark:

1. The largest summation of CDMA2000, Bluetooth and WLAN for body SAR is 1.518 W/kg and its position is Rear Face with 0 cm gap.
2. Test Engineer: Gordon Lin, Jason Wang, Eric Huang, and Robert Liu.



12 References

- [1] FCC 47 CFR Part 2 “Frequency Allocations and Radio Treaty Matters; General Rules and Regulations”
- [2] IEEE Std. P1528-2003, “Recommended Practice for Determining the Peak Spatial-Average Specific Absorption Rate (SAR) in the Human Head from Wireless Communications Devices: Measurement Techniques”, April 21, 2003
- [3] Supplement C (Edition 01-01) to OET Bulletin 65 (Edition 97-01), “Additional Information for Evaluating Compliance of Mobile and Portable Devices with FCC Limits for Human Exposure to RF Emissions”, June 2001
- [4] IEEE Std. C95.3-2002, “IEEE Recommended Practice for the Measurement of Potentially Hazardous Electromagnetic Fields-RF and Microwave”, 2002
- [5] IEEE Std. C95.1-1999, “IEEE Standard for Safety Levels with Respect to Human Exposure to Radio Frequency Electromagnetic Fields, 3 kHz to 300 GHz”, 1999
- [6] Robert J. Renka, “Multivariate Interpolation Of Large Sets Of Scattered Data”, University of North Texas ACM Transactions on Mathematical Software, vol. 14, no. 2, June 1988, pp. 139-148
- [7] DAYS4 System Handbook

Appendix A - System Performance Check Data

Test Laboratory: Sporton International Inc. SAR/HAC Testing Lab

Date: 2007/12/20

System Check_Body_835MHz

DUT: Dipole 835 MHz

Communication System: CW; Frequency: 835 MHz; Duty Cycle: 1:1

Medium: MSL_850 Medium parameters used: $f = 835 \text{ MHz}$; $\sigma = 0.969 \text{ mho/m}$; $\epsilon_r = 55.1$; $\rho = 1000 \text{ kg/m}^3$

Ambient Temperature : 21.8 °C; Liquid Temperature : 21.2 °C

DASY4 Configuration:

- Probe: ET3DV6 - SN1787; ConvF(6.1, 6.1, 6.1); Calibrated: 2007/8/28

- Sensor-Surface: 4mm (Mechanical And Optical Surface Detection) Sensor-Surface: 4mm (Mechanical Surface Detection)

- Electronics: DAE4 Sn778; Calibrated: 2007/9/17

- Phantom: ELI 4.0; Type: QDOVA001BA; Serial: 1029

- Measurement SW: DASY4, V4.7 Build 55; Postprocessing SW: SEMCAD, V1.8 Build 176

Pin=100mW/Area Scan (61x61x1): Measurement grid: dx=15mm, dy=15mm

Maximum value of SAR (interpolated) = 1.10 mW/g

Pin=100mW/Zoom Scan (7x7x7)/Cube 0: Measurement grid: dx=5mm, dy=5mm, dz=5mm

Reference Value = 35.1 V/m; Power Drift = 0.033 dB

Peak SAR (extrapolated) = 1.48 W/kg

SAR(1 g) = 1.02 mW/g; SAR(10 g) = 0.682 mW/g

Maximum value of SAR (measured) = 1.10 mW/g

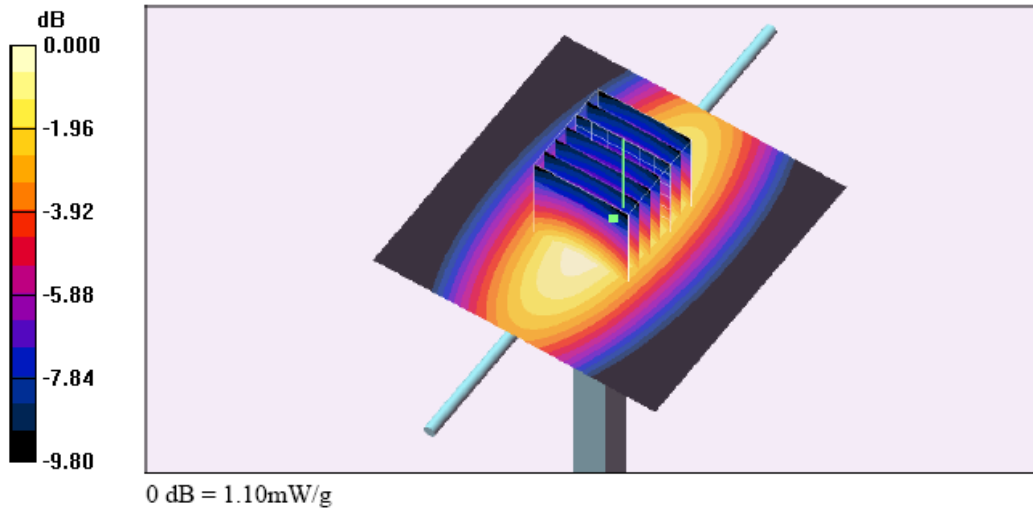

Test Laboratory: Sporton International Inc. SAR/HAC Testing Lab

Date: 2007/12/21

System Check_Body_1900MHz

DUT: Dipole 1900 MHz

Communication System: CW; Frequency: 1900 MHz; Duty Cycle: 1:1

Medium: MSL_1900 Medium parameters used: f = 1900 MHz; $\sigma = 1.56$ mho/m; $\epsilon_r = 51.8$; $\rho = 1000$ kg/m³

Ambient Temperature : 22.9 °C; Liquid Temperature : 21.6 °C

DASY4 Configuration:

- Probe: ET3DV6 - SN1787; ConvF(4.68, 4.68, 4.68); Calibrated: 2007/8/28
- Sensor-Surface: 4mm (Mechanical And Optical Surface Detection) Sensor-Surface: 4mm (Mechanical Surface Detection)
- Electronics: DAE4 Sn778; Calibrated: 2007/9/17
- Phantom: ELI 4.0; Type: QDOVA001BA; Serial: 1029
- Measurement SW: DASY4, V4.7 Build 55; Postprocessing SW: SEMCAD, V1.8 Build 176

Pin=100mW/Area Scan (91x91x1): Measurement grid: dx=10mm, dy=10mm

Maximum value of SAR (interpolated) = 4.86 mW/g

Pin=100mW/Zoom Scan (7x7x7)/Cube 0: Measurement grid: dx=5mm, dy=5mm, dz=5mm

Reference Value = 57.8 V/m; Power Drift = 0.018 dB

Peak SAR (extrapolated) = 6.98 W/kg

SAR(1 g) = 4.14 mW/g; SAR(10 g) = 2.2 mW/g

Maximum value of SAR (measured) = 4.75 mW/g

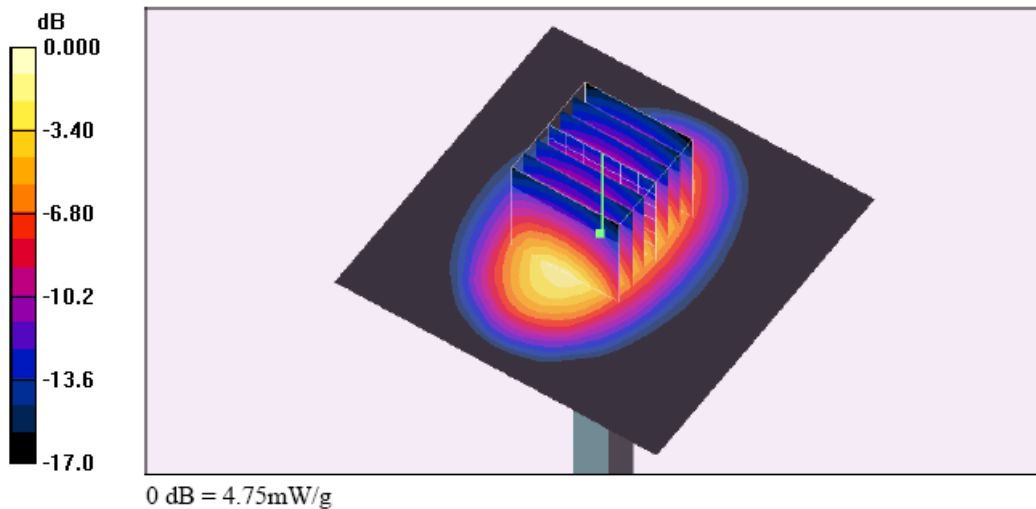

Appendix B - SAR Measurement Data

Test Laboratory: Sporton International Inc. SAR/HAC Testing Lab

Date: 2007/12/20

Body_CDMA2000 Ch384_Front Face with 0cm Gap_1xRTT_FCH-RC1_Ant Retract

DUT: 7N3014

Communication System: CDMA ; Frequency: 836.52 MHz;Duty Cycle: 1:1

Medium: MSL_850 Medium parameters used: f = 837 MHz; $\sigma = 0.971$ mho/m; $\epsilon_r = 55.1$; $\rho = 1000$ kg/m³

Ambient Temperature : 21.9 °C; Liquid Temperature : 21.2 °C

DASY4 Configuration:

- Probe: ET3DV6 - SN1787; ConvF(6.1, 6.1, 6.1); Calibrated: 2007/8/28

- Sensor-Surface: 4mm (Mechanical Surface Detection)

- Electronics: DAE4 Sn778; Calibrated: 2007/9/17

- Phantom: ELI 4.0; Type: QDOVA001BA; Serial: 1029

- Measurement SW: DASY4, V4.7 Build 55; Postprocessing SW: SEMCAD, V1.8 Build 176

Ch384/Area Scan (181x211x1): Measurement grid: dx=15mm, dy=15mm

Maximum value of SAR (interpolated) = 0.004 mW/g

Ch384/Zoom Scan (5x5x7)/Cube 0: Measurement grid: dx=8mm, dy=8mm, dz=5mm

Reference Value = 0.077 V/m; Power Drift = 0.166 dB

Peak SAR (extrapolated) = 0.003 W/kg

SAR(1 g) = 0.00188 mW/g; SAR(10 g) = 0.000822 mW/g

Maximum value of SAR (measured) = 0.002 mW/g

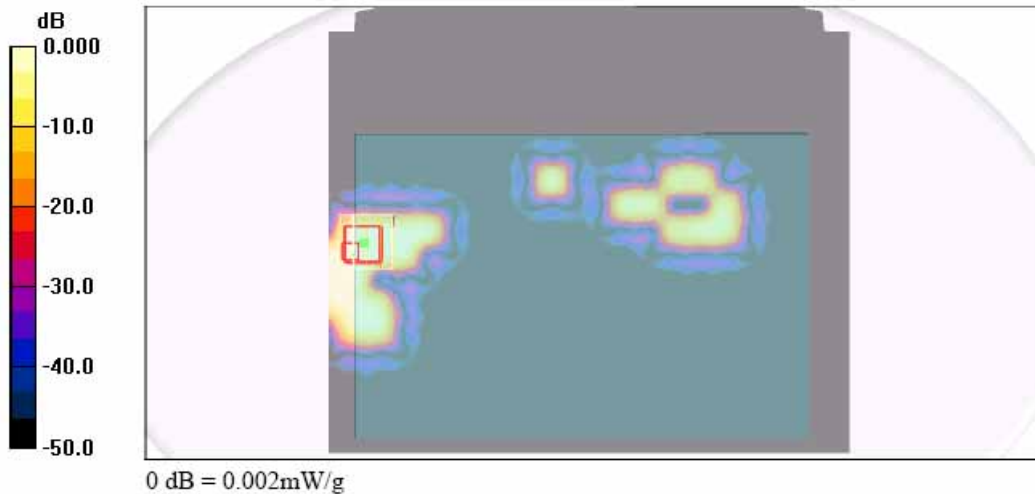

Test Laboratory: Sporton International Inc. SAR/HAC Testing Lab

Date: 2007/12/20

Body_CDMA2000 Ch384_Front Face with 0cm Gap_1xRTT_FCH-RC1_Ant Extend

DUT: 7N3014

Communication System: CDMA ; Frequency: 836.52 MHz; Duty Cycle: 1:1

Medium: MSL_850 Medium parameters used: $f = 837 \text{ MHz}$; $\sigma = 0.971 \text{ mho/m}$; $\epsilon_r = 55.1$; $\rho = 1000 \text{ kg/m}^3$

Ambient Temperature : 21.9 °C; Liquid Temperature : 21.2 °C

DASY4 Configuration:

- Probe: ET3DV6 - SN1787; ConvF(6.1, 6.1, 6.1); Calibrated: 2007/8/28
- Sensor-Surface: 4mm (Mechanical Surface Detection)
- Electronics: DAE4 Sn778; Calibrated: 2007/9/17
- Phantom: ELI 4.0; Type: QDOVA001BA; Serial: 1029
- Measurement SW: DASY4, V4.7 Build 55; Postprocessing SW: SEMCAD, V1.8 Build 176

Ch384/Area Scan (181x211x1): Measurement grid: dx=15mm, dy=15mm

Maximum value of SAR (interpolated) = 0.787 mW/g

Ch384/Zoom Scan (5x5x7)/Cube 0: Measurement grid: dx=8mm, dy=8mm, dz=5mm

Reference Value = 2.67 V/m; Power Drift = -0.140 dB

Peak SAR (extrapolated) = 1.21 W/kg

SAR(1 g) = 0.772 mW/g; SAR(10 g) = 0.486 mW/g

Maximum value of SAR (measured) = 0.823 mW/g

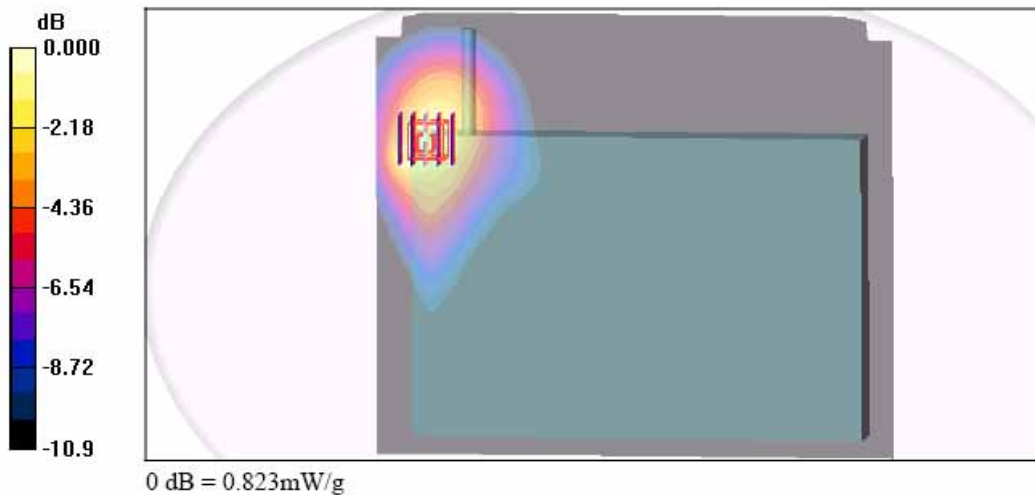

Test Laboratory: Sporton International Inc. SAR/HAC Testing Lab

Date: 2007/12/20

Body_CDMA2000 Ch1013_Rear Face with 0cm Gap_1xRTT_FCH-RC1_Ant Extend_ for E100

DUT: 7N3014

Communication System: CDMA ; Frequency: 824.7 MHz; Duty Cycle: 1:1

Medium: MSL_850 Medium parameters used: $f = 825$ MHz; $\sigma = 0.959$ mho/m; $\epsilon_r = 55.3$; $\rho = 1000$ kg/m³

Ambient Temperature : 22.5 °C; Liquid Temperature : 21.2 °C

DASY4 Configuration:

- Probe: ET3DV6 - SN1787; ConvF(6.1, 6.1, 6.1); Calibrated: 2007/8/28
- Sensor-Surface: 4mm (Mechanical Surface Detection)
- Electronics: DAE4 Sn778; Calibrated: 2007/9/17
- Phantom: ELI 4.0; Type: QDOVA001BA; Serial: 1029
- Measurement SW: DASY4, V4.7 Build 55; Postprocessing SW: SEMCAD, V1.8 Build 176

Ch1013/Area Scan (61x51x1): Measurement grid: dx=15mm, dy=15mm

Maximum value of SAR (interpolated) = 1.46 mW/g

Ch1013/Zoom Scan (5x5x7)/Cube 0: Measurement grid: dx=8mm, dy=8mm, dz=5mm

Reference Value = 6.12 V/m; Power Drift = 0.145 dB

Peak SAR (extrapolated) = 1.89 W/kg

SAR(1 g) = 1.32 mW/g; SAR(10 g) = 0.875 mW/g

Maximum value of SAR (measured) = 1.41 mW/g

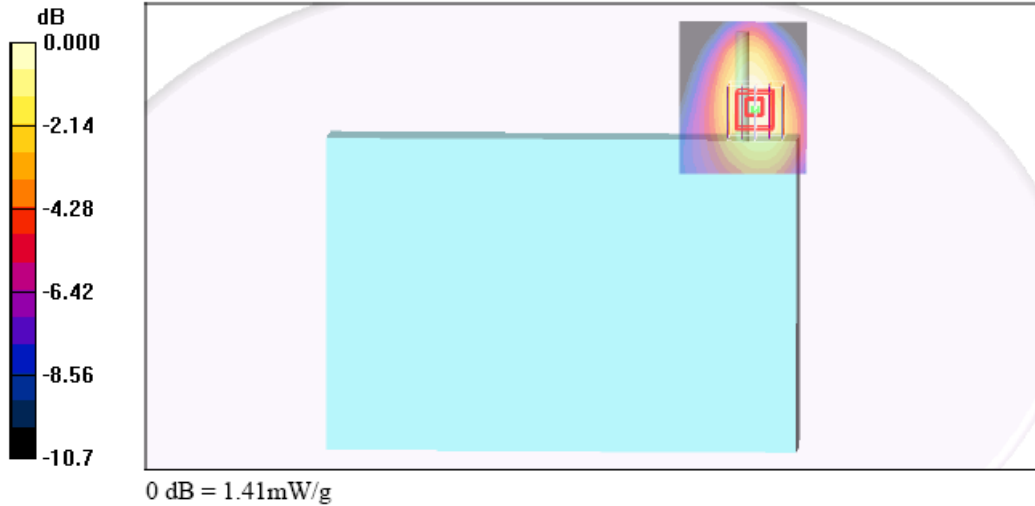

Test Laboratory: Sporton International Inc. SAR/HAC Testing Lab

Date: 2007/12/20

Body_CDMA2000 Ch384_Rear Face with 0cm Gap_1xRTT_FCH-RC1_Ant Retract

DUT: 7N3014

Communication System: CDMA ; Frequency: 836.52 MHz; Duty Cycle: 1:1

Medium: MSL_850 Medium parameters used: $f = 837 \text{ MHz}$; $\sigma = 0.971 \text{ mho/m}$; $\epsilon_r = 55.1$; $\rho = 1000 \text{ kg/m}^3$

Ambient Temperature : 22.90 °C; Liquid Temperature : 21.2 °C

DASY4 Configuration:

- Probe: ET3DV6 - SN1787; ConvF(6.1, 6.1, 6.1); Calibrated: 2007/8/28
- Sensor-Surface: 4mm (Mechanical Surface Detection)
- Electronics: DAE4 Sn778; Calibrated: 2007/9/17
- Phantom: ELI 4.0; Type: QDOVA001BA; Serial: 1029
- Measurement SW: DASY4, V4.7 Build 55; Postprocessing SW: SEMCAD, V1.8 Build 176

Ch384/Area Scan (181x211x1): Measurement grid: dx=15mm, dy=15mm

Maximum value of SAR (interpolated) = 0.000 mW/g

Ch384/Zoom Scan (5x5x7)/Cube 0: Measurement grid: dx=8mm, dy=8mm, dz=5mm

Reference Value = 0.154 V/m; Power Drift = 0.197 dB

Peak SAR (extrapolated) = 0.002 W/kg

SAR(1 g) = 8.88e-005 mW/g; SAR(10 g) = 1.39e-005 mW/g

Maximum value of SAR (measured) = 0.001 mW/g

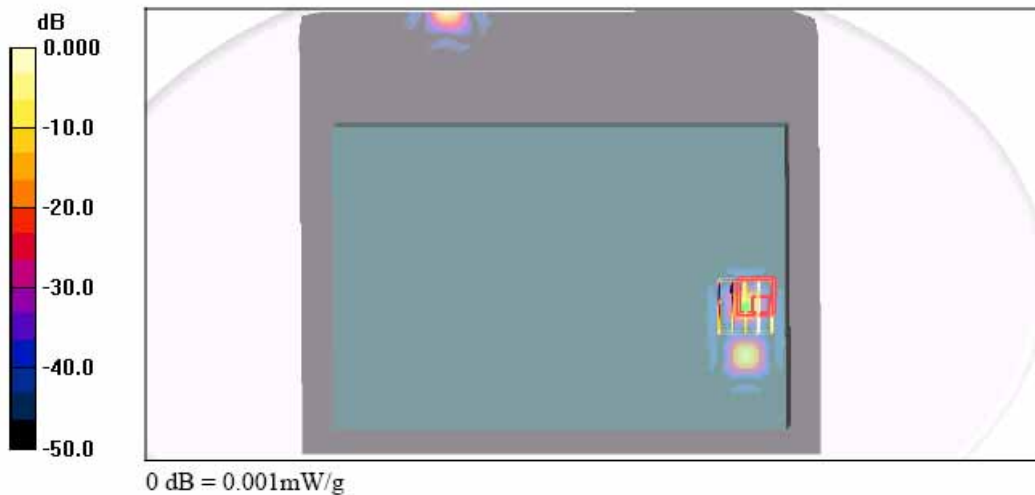

Test Laboratory: Sporton International Inc. SAR/HAC Testing Lab

Date: 2007/12/20

Body_CDMA2000 Ch384_Rear Face with 0cm Gap_1xRTT_FCH-RC3_Ant Extend

DUT: 7N3014

Communication System: CDMA ; Frequency: 836.52 MHz; Duty Cycle: 1:1

Medium: MSL_850 Medium parameters used: $f = 837 \text{ MHz}$; $\sigma = 0.971 \text{ mho/m}$; $\epsilon_r = 55.1$; $\rho = 1000 \text{ kg/m}^3$

Ambient Temperature : 21.7 °C ; Liquid Temperature : 21.2 °C

DASY4 Configuration:

- Probe: ET3DV6 - SN1787; ConvF(6.1, 6.1, 6.1); Calibrated: 2007/8/28
- Sensor-Surface: 4mm (Mechanical Surface Detection)
- Electronics: DAE4 Sn778; Calibrated: 2007/9/17
- Phantom: ELI 4.0; Type: QDOVA001BA; Serial: 1029
- Measurement SW: DASY4, V4.7 Build 55; Postprocessing SW: SEMCAD, V1.8 Build 176

Ch384/Area Scan (101x101x1): Measurement grid: dx=15mm, dy=15mm

Maximum value of SAR (interpolated) = 1.45 mW/g

Ch384/Zoom Scan (5x5x7)/Cube 0: Measurement grid: dx=8mm, dy=8mm, dz=5mm

Reference Value = 5.64 V/m; Power Drift = -0.014 dB

Peak SAR (extrapolated) = 2.00 W/kg

SAR(1 g) = 1.32 mW/g; SAR(10 g) = 0.861 mW/g

Maximum value of SAR (measured) = 1.42 mW/g

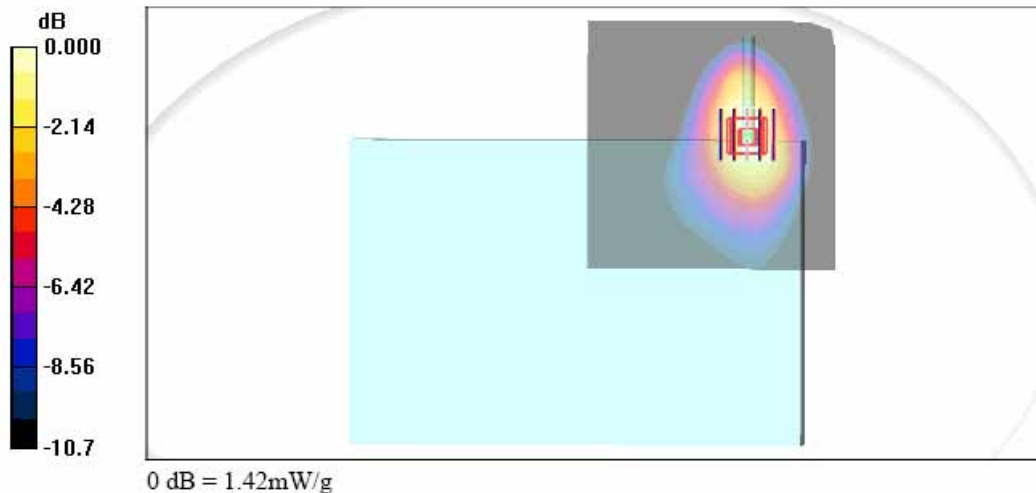

Test Laboratory: Sporton International Inc. SAR/HAC Testing Lab

Date: 2007/12/20

Body_CDMA2000 Ch384_Rear Face with 0cm Gap_1x-RTT_FCH+SCH-RC3_Ant Extend**DUT: 7N3014**

Communication System: CDMA ; Frequency: 836.52 MHz; Duty Cycle: 1:1

Medium: MSL_850 Medium parameters used: $f = 837$ MHz; $\sigma = 0.971$ mho/m; $\epsilon_r = 55.1$; $\rho = 1000$ kg/m³

Ambient Temperature : 21.9 °C ; Liquid Temperature : 21.2 °C

DASY4 Configuration:

- Probe: ET3DV6 - SN1787; ConvF(6.1, 6.1, 6.1); Calibrated: 2007/8/28
- Sensor-Surface: 4mm (Mechanical Surface Detection)
- Electronics: DAE4 Sn778; Calibrated: 2007/9/17
- Phantom: ELI 4.0; Type: QDOVA001BA; Serial: 1029
- Measurement SW: DASY4, V4.7 Build 55; Postprocessing SW: SEMCAD, V1.8 Build 176

Ch384/Area Scan (101x101x1): Measurement grid: dx=15mm, dy=15mm

Maximum value of SAR (interpolated) = 1.42 mW/g

Ch384/Zoom Scan (5x5x7)/Cube 0: Measurement grid: dx=8mm, dy=8mm, dz=5mm

Reference Value = 5.67 V/m; Power Drift = 0.045 dB

Peak SAR (extrapolated) = 1.88 W/kg

SAR(1 g) = 1.31 mW/g; SAR(10 g) = 0.857 mW/g

Maximum value of SAR (measured) = 1.40 mW/g

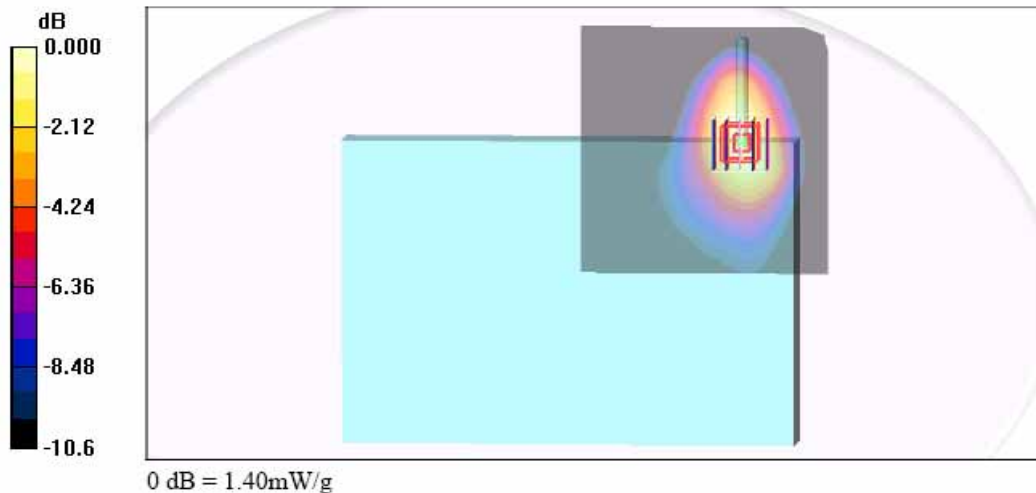

Test Laboratory: Sporton International Inc. SAR/HAC Testing Lab

Date: 2007/12/21

Body_CDMA2000 Ch384_Rear Face with 0cm Gap_1xEVDO_Rev0_RTAP_9.6K_Ant Extend

DUT: 7N3014

Communication System: CDMA ; Frequency: 836.52 MHz;Duty Cycle: 1:1

Medium: MSL_850 Medium parameters used: $f = 837$ MHz; $\sigma = 0.971$ mho/m; $\epsilon_r = 55.1$; $\rho = 1000$ kg/m³

Ambient Temperature : 22.9 °C; Liquid Temperature : 21.2 °C

DASY4 Configuration:

- Probe: ET3DV6 - SN1787; ConvF(6.1, 6.1, 6.1); Calibrated: 2007/8/28
- Sensor-Surface: 4mm (Mechanical Surface Detection)
- Electronics: DAE4 Sn778; Calibrated: 2007/9/17
- Phantom: ELI 4.0; Type: QDOVA001BA; Serial: 1029
- Measurement SW: DASY4, V4.7 Build 55; Postprocessing SW: SEMCAD, V1.8 Build 176

Ch384/Area Scan (101x101x1): Measurement grid: dx=15mm, dy=15mm

Maximum value of SAR (interpolated) = 1.12 mW/g

Ch384/Zoom Scan (5x5x7)/Cube 0: Measurement grid: dx=8mm, dy=8mm, dz=5mm

Reference Value = 5.49 V/m; Power Drift = 0.018 dB

Peak SAR (extrapolated) = 1.45 W/kg

SAR(1 g) = 1.04 mW/g; SAR(10 g) = 0.684 mW/g

Maximum value of SAR (measured) = 1.13 mW/g

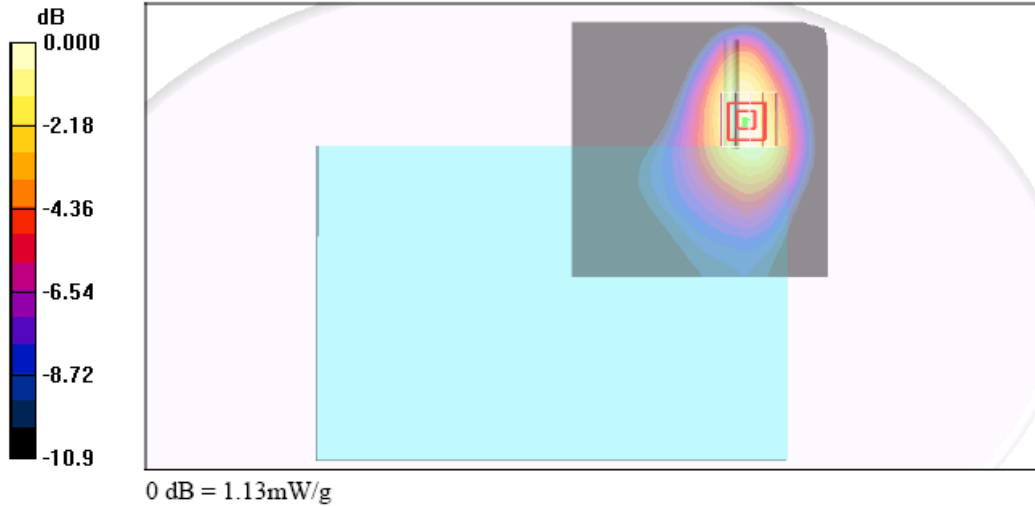

Test Laboratory: Sporton International Inc. SAR/HAC Testing Lab

Date: 2007/12/20

Body_CDMA2000 Ch384_Rear Face with 0cm Gap_1xEVDO_Rev0_RTAP_38.4K_Ant Extend**DUT: 7N3014**

Communication System: CDMA ; Frequency: 836.52 MHz; Duty Cycle: 1:1

Medium: MSL_850 Medium parameters used: $f = 837$ MHz; $\sigma = 0.971$ mho/m; $\epsilon_r = 55.1$; $\rho = 1000$ kg/m³

Ambient Temperature : 22.9 °C; Liquid Temperature : 21.2 °C

DASY4 Configuration:

- Probe: ET3DV6 - SN1787; ConvF(6.1, 6.1, 6.1); Calibrated: 2007/8/28
- Sensor-Surface: 4mm (Mechanical Surface Detection)
- Electronics: DAE4 Sn778; Calibrated: 2007/9/17
- Phantom: ELI 4.0; Type: QDOVA001BA; Serial: 1029
- Measurement SW: DASY4, V4.7 Build 55; Postprocessing SW: SEMCAD, V1.8 Build 176

Ch384/Area Scan (101x101x1): Measurement grid: dx=15mm, dy=15mm

Maximum value of SAR (interpolated) = 1.22 mW/g

Ch384/Zoom Scan (5x5x7)/Cube 0: Measurement grid: dx=8mm, dy=8mm, dz=5mm

Reference Value = 5.34 V/m; Power Drift = 0.144 dB

Peak SAR (extrapolated) = 1.56 W/kg

SAR(1 g) = 1.06 mW/g; SAR(10 g) = 0.696 mW/g

Maximum value of SAR (measured) = 1.13 mW/g

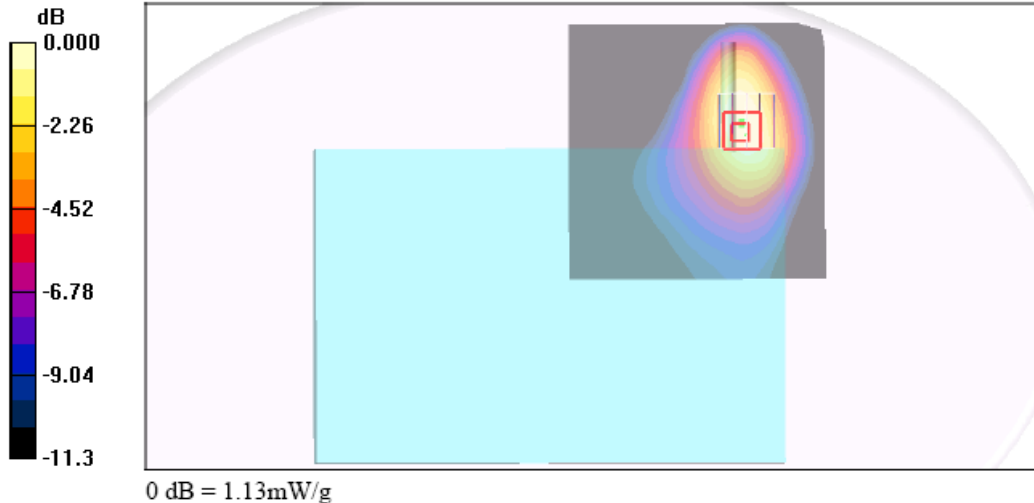

Test Laboratory: Sporton International Inc. SAR/HAC Testing Lab

Date: 2007/12/20

Body_CDMA2000 Ch384_Rear Face with 0cm Gap_1xEVDO_Rev0_RTAP_153.6K_Ant Extend

DUT: 7N3014

Communication System: CDMA ; Frequency: 836.52 MHz; Duty Cycle: 1:1

Medium: MSL_850 Medium parameters used: $f = 837$ MHz; $\sigma = 0.971$ mho/m; $\epsilon_r = 55.1$; $\rho = 1000$ kg/m³

Ambient Temperature : 22.9 °C; Liquid Temperature : 21.2 °C

DASY4 Configuration:

- Probe: ET3DV6 - SN1787; ConvF(6.1, 6.1, 6.1); Calibrated: 2007/8/28
- Sensor-Surface: 4mm (Mechanical Surface Detection)
- Electronics: DAE4 Sn778; Calibrated: 2007/9/17
- Phantom: ELI 4.0; Type: QDOVA001BA; Serial: 1029
- Measurement SW: DASY4, V4.7 Build 55; Postprocessing SW: SEMCAD, V1.8 Build 176

Ch384/Area Scan (101x101x1): Measurement grid: dx=15mm, dy=15mm

Maximum value of SAR (interpolated) = 1.23 mW/g

Ch384/Zoom Scan (5x5x7)/Cube 0: Measurement grid: dx=8mm, dy=8mm, dz=5mm

Reference Value = 5.60 V/m; Power Drift = 0.025 dB

Peak SAR (extrapolated) = 1.67 W/kg

SAR(1 g) = 1.15 mW/g; SAR(10 g) = 0.755 mW/g

Maximum value of SAR (measured) = 1.22 mW/g

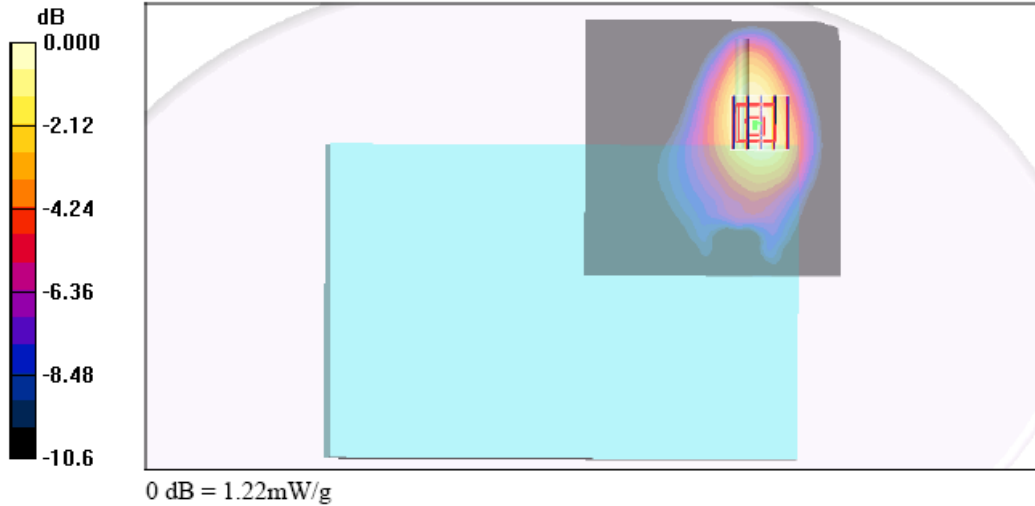

Test Laboratory: Sporton International Inc. SAR/HAC Testing Lab

Date: 2007/12/20

Body_CDMA2000 Ch384_Rear Face with 0cm Gap_1xEVDO_RevA_RETAP_128_Ant Extend

DUT: 7N3014

Communication System: CDMA ; Frequency: 836.52 MHz; Duty Cycle: 1:1

Medium: MSL_850 Medium parameters used: $f = 837$ MHz; $\sigma = 0.971$ mho/m; $\epsilon_r = 55.1$; $\rho = 1000$ kg/m³

Ambient Temperature : 22.9 °C; Liquid Temperature : 21.2 °C

DASY4 Configuration:

- Probe: ET3DV6 - SN1787; ConvF(6.1, 6.1, 6.1); Calibrated: 2007/8/28
- Sensor-Surface: 4mm (Mechanical Surface Detection)
- Electronics: DAE4 Sn778; Calibrated: 2007/9/17
- Phantom: ELI 4.0; Type: QDOVA001BA; Serial: 1029
- Measurement SW: DASY4, V4.7 Build 55; Postprocessing SW: SEMCAD, V1.8 Build 176

Ch384/Area Scan (101x101x1): Measurement grid: dx=15mm, dy=15mm

Maximum value of SAR (interpolated) = 1.11 mW/g

Ch384/Zoom Scan (5x5x7)/Cube 0: Measurement grid: dx=8mm, dy=8mm, dz=5mm

Reference Value = 5.69 V/m; Power Drift = 0.077 dB

Peak SAR (extrapolated) = 1.56 W/kg

SAR(1 g) = 1.09 mW/g; SAR(10 g) = 0.715 mW/g

Maximum value of SAR (measured) = 1.15 mW/g

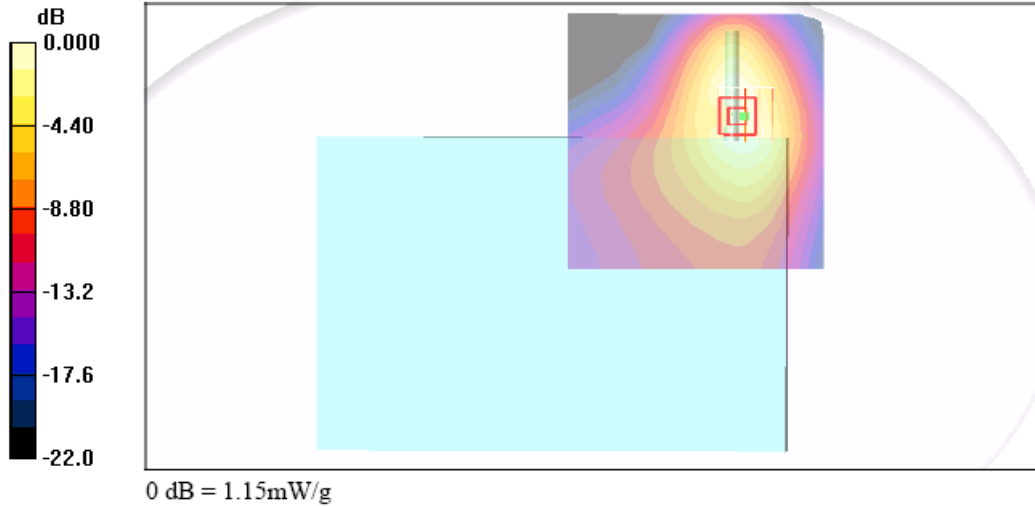

Test Laboratory: Sporton International Inc. SAR/HAC Testing Lab

Date: 2007/12/20

Body_CDMA2000 Ch384_Rear Face with 0cm Gap_1xEVDO_RevA_RETAP_2048_Ant Extend

DUT: 7N3014

Communication System: CDMA ; Frequency: 836.52 MHz; Duty Cycle: 1:1

Medium: MSL_850 Medium parameters used: $f = 837$ MHz; $\sigma = 0.971$ mho/m; $\epsilon_r = 55.1$; $\rho = 1000$ kg/m³

Ambient Temperature : 22.9 °C; Liquid Temperature : 21.2 °C

DASY4 Configuration:

- Probe: ET3DV6 - SN1787; ConvF(6.1, 6.1, 6.1); Calibrated: 2007/8/28
- Sensor-Surface: 4mm (Mechanical Surface Detection)
- Electronics: DAE4 Sn778; Calibrated: 2007/9/17
- Phantom: ELI 4.0; Type: QDOVA001BA; Serial: 1029
- Measurement SW: DASY4, V4.7 Build 55; Postprocessing SW: SEMCAD, V1.8 Build 176

Ch384/Area Scan (101x101x1): Measurement grid: dx=15mm, dy=15mm

Maximum value of SAR (interpolated) = 1.19 mW/g

Ch384/Zoom Scan (5x5x7)/Cube 0: Measurement grid: dx=8mm, dy=8mm, dz=5mm

Reference Value = 5.67 V/m; Power Drift = 0.095 dB

Peak SAR (extrapolated) = 1.60 W/kg

SAR(1 g) = 1.1 mW/g; SAR(10 g) = 0.721 mW/g

Maximum value of SAR (measured) = 1.17 mW/g

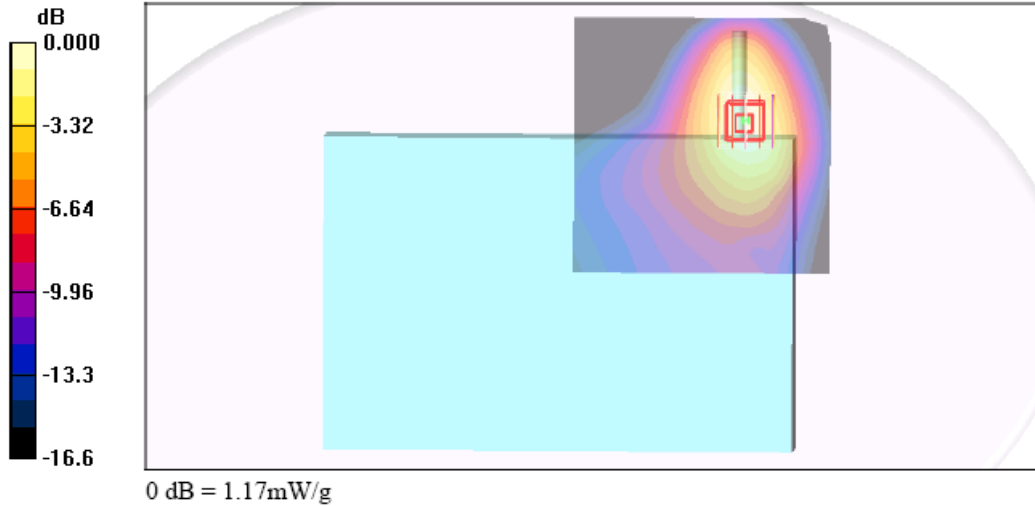

Test Laboratory: Sporton International Inc. SAR/HAC Testing Lab

Date: 2007/12/20

Body_CDMA2000 Ch384_Rear Face with 0cm Gap_1xEVDO_RevA_RETAP_12288_Ant Extend

DUT: 7N3014

Communication System: CDMA ; Frequency: 836.52 MHz; Duty Cycle: 1:1

Medium: MSL_850 Medium parameters used: $f = 837$ MHz; $\sigma = 0.971$ mho/m; $\epsilon_r = 55.1$; $\rho = 1000$ kg/m³

Ambient Temperature : 22.8 °C; Liquid Temperature : 21.2 °C

DASY4 Configuration:

- Probe: ET3DV6 - SN1787; ConvF(6.1, 6.1, 6.1); Calibrated: 2007/8/28
- Sensor-Surface: 4mm (Mechanical Surface Detection)
- Electronics: DAE4 Sn778; Calibrated: 2007/9/17
- Phantom: ELI 4.0; Type: QDOVA001BA; Serial: 1029
- Measurement SW: DASY4, V4.7 Build 55; Postprocessing SW: SEMCAD, V1.8 Build 176

Ch384/Area Scan (101x101x1): Measurement grid: dx=15mm, dy=15mm

Maximum value of SAR (interpolated) = 1.14 mW/g

Ch384/Zoom Scan (5x5x7)/Cube 0: Measurement grid: dx=8mm, dy=8mm, dz=5mm

Reference Value = 5.65 V/m; Power Drift = 0.021 dB

Peak SAR (extrapolated) = 1.59 W/kg

SAR(1 g) = 1.08 mW/g; SAR(10 g) = 0.710 mW/g

Maximum value of SAR (measured) = 1.16 mW/g

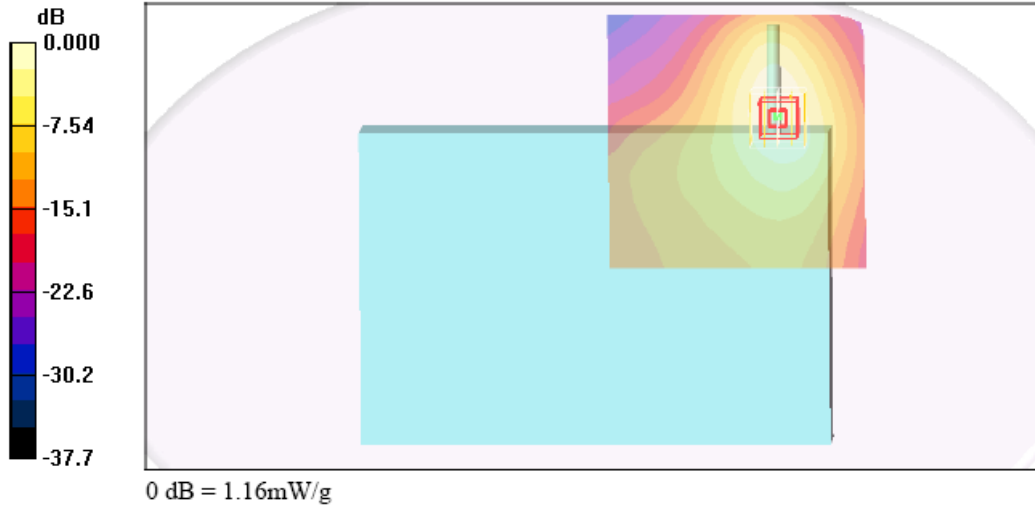

Test Laboratory: Sporton International Inc. SAR/HAC Testing Lab

Date: 2007/12/20

Body_CDMA2000 Ch384_Top Side with 0cm Gap_1xRTT_FCH-RC1_Ant Retract

DUT: 7N3014

Communication System: CDMA ; Frequency: 836.52 MHz; Duty Cycle: 1:1

Medium: MSL_850 Medium parameters used: $f = 837 \text{ MHz}$; $\sigma = 0.971 \text{ mho/m}$; $\epsilon_r = 55.1$; $\rho = 1000 \text{ kg/m}^3$

Ambient Temperature : 21.5 °C ; Liquid Temperature : 21.2 °C

DASY4 Configuration:

- Probe: ET3DV6 - SN1787; ConvF(6.1, 6.1, 6.1); Calibrated: 2007/8/28
- Sensor-Surface: 4mm (Mechanical Surface Detection)
- Electronics: DAE4 Sn778; Calibrated: 2007/9/17
- Phantom: ELI 4.0; Type: QDOVA001BA; Serial: 1029
- Measurement SW: DASY4, V4.7 Build 55; Postprocessing SW: SEMCAD, V1.8 Build 176

Ch384/Area Scan (71x201x1): Measurement grid: $dx=15\text{mm}$, $dy=15\text{mm}$

Maximum value of SAR (interpolated) = 0.000 mW/g

Ch384/Zoom Scan (5x5x7)/Cube 0: Measurement grid: $dx=8\text{mm}$, $dy=8\text{mm}$, $dz=5\text{mm}$

Reference Value = 0.044 V/m; Power Drift = 0.116 dB

Peak SAR (extrapolated) = 0.001 W/kg

SAR(1 g) = 0.000296 mW/g; SAR(10 g) = 5.95e-005 mW/g

Maximum value of SAR (measured) = 0.001 mW/g

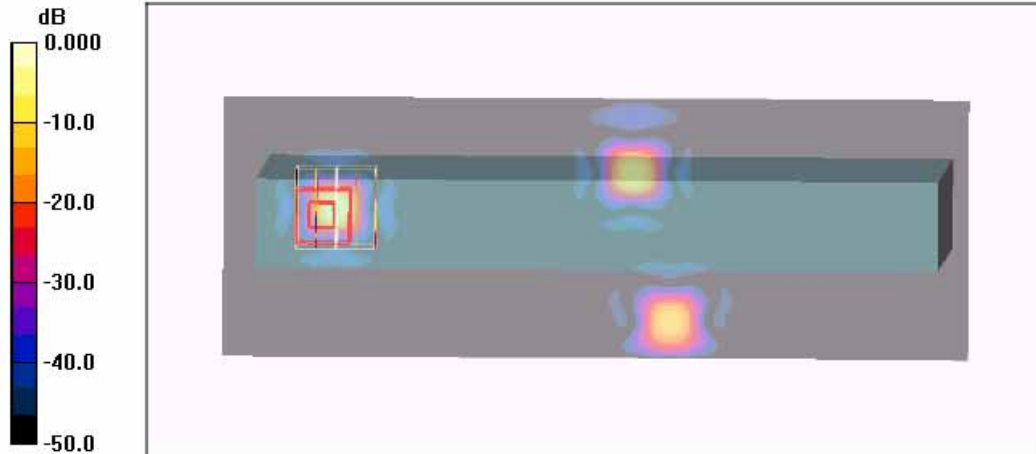

0 dB = 0.001mW/g

Test Laboratory: Sporton International Inc. SAR/HAC Testing Lab

Date: 2007/12/20

Body_CDMA2000 Ch384_Bottom Side with 0cm Gap_1xRTT_FCH-RC1_Ant Retract

DUT: 7N3014

Communication System: CDMA ; Frequency: 836.52 MHz; Duty Cycle: 1:1

Medium: MSL_850 Medium parameters used: $f = 837 \text{ MHz}$; $\sigma = 0.971 \text{ mho/m}$; $\epsilon_r = 55.1$; $\rho = 1000 \text{ kg/m}^3$

Ambient Temperature : 21.7 °C; Liquid Temperature : 21.2 °C

DASY4 Configuration:

- Probe: ET3DV6 - SN1787; ConvF(6.1, 6.1, 6.1); Calibrated: 2007/8/28
- Sensor-Surface: 4mm (Mechanical Surface Detection)
- Electronics: DAE4 Sn778; Calibrated: 2007/9/17
- Phantom: ELI 4.0; Type: QDOVA001BA; Serial: 1029
- Measurement SW: DASY4, V4.7 Build 55; Postprocessing SW: SEMCAD, V1.8 Build 176

Ch384/Area Scan (71x201x1): Measurement grid: dx=15mm, dy=15mm

Maximum value of SAR (interpolated) = 0.000 mW/g

Ch384/Zoom Scan (5x5x7)/Cube 0: Measurement grid: dx=8mm, dy=8mm, dz=5mm

Reference Value = 0.310 V/m; Power Drift = -0.125dB

Peak SAR (extrapolated) = 0.000 W/kg

SAR(1 g) = 3.96e-005 mW/g; SAR(10 g) = 4.8e-006 mW/g

Maximum value of SAR (measured) = 0.001 mW/g



Test Laboratory: Sporton International Inc. SAR/HAC Testing Lab

Date: 2007/12/20

Body_CDMA2000 Ch384_Bottom Side with 0cm Gap_1xRTT_FCH-RC1_Ant Extend

DUT: 7N3014

Communication System: CDMA ; Frequency: 836.52 MHz; Duty Cycle: 1:1

Medium: MSL_850 Medium parameters used: $f = 837 \text{ MHz}$; $\sigma = 0.971 \text{ mho/m}$; $\epsilon_r = 55.1$; $\rho = 1000 \text{ kg/m}^3$

Ambient Temperature : 21.6 °C; Liquid Temperature : 21.2 °C

DASY4 Configuration:

- Probe: ET3DV6 - SN1787; ConvF(6.1, 6.1, 6.1); Calibrated: 2007/8/28
- Sensor-Surface: 4mm (Mechanical Surface Detection)
- Electronics: DAE4 Sn778; Calibrated: 2007/9/17
- Phantom: ELI 4.0; Type: QDOVA001BA; Serial: 1029
- Measurement SW: DASY4, V4.7 Build 55; Postprocessing SW: SEMCAD, V1.8 Build 176

Ch384/Area Scan (71x201x1): Measurement grid: $dx=15\text{mm}$, $dy=15\text{mm}$

Maximum value of SAR (interpolated) = 0.052 mW/g

Ch384/Zoom Scan (5x5x7)/Cube 0: Measurement grid: $dx=8\text{mm}$, $dy=8\text{mm}$, $dz=5\text{mm}$

Reference Value = 2.88 V/m; Power Drift = 0.104 dB

Peak SAR (extrapolated) = 0.084 W/kg

SAR(1 g) = 0.046 mW/g; SAR(10 g) = 0.028 mW/g

Maximum value of SAR (measured) = 0.047 mW/g

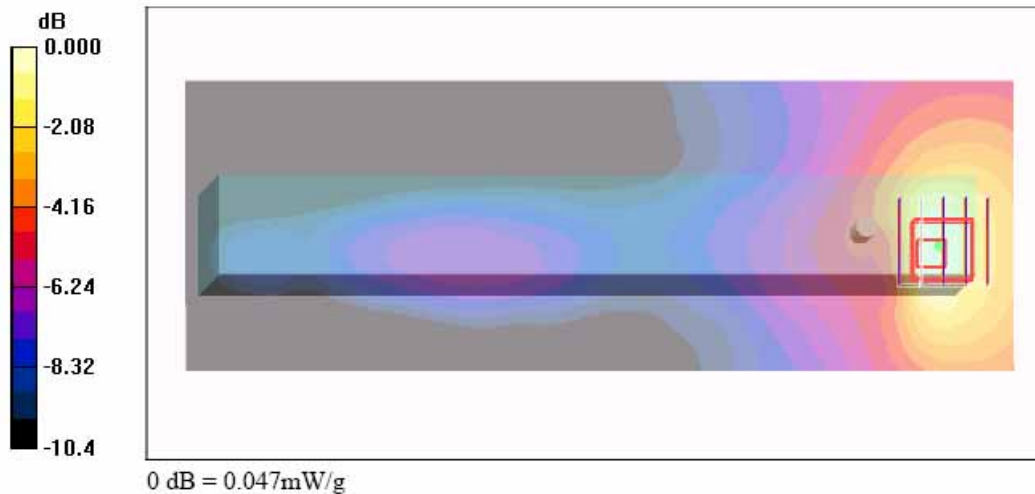

Test Laboratory: Sporton International Inc. SAR/HAC Testing Lab

Date: 2007/12/20

Body_CDMA2000 Ch384_Right Side with 0cm Gap_1xRTT_FCH-RC1_Ant Retract

DUT: 7N3014

Communication System: CDMA ; Frequency: 836.52 MHz;Duty Cycle: 1:1

Medium: MSL_850 Medium parameters used: f = 837 MHz; $\sigma = 0.971$ mho/m; $\epsilon_r = 55.1$; $\rho = 1000$ kg/m³

Ambient Temperature : 21.9 °C; Liquid Temperature : 21.2 °C

DASY4 Configuration:

- Probe: ET3DV6 - SN1787; ConvF(6.1, 6.1, 6.1); Calibrated: 2007/8/28
- Sensor-Surface: 4mm (Mechanical Surface Detection)
- Electronics: DAE4 Sn778; Calibrated: 2007/9/17
- Phantom: ELI 4.0; Type: QDOVA001BA; Serial: 1029
- Measurement SW: DASY4, V4.7 Build 55; Postprocessing SW: SEMCAD, V1.8 Build 176

Ch384/Area Scan (71x181x1): Measurement grid: dx=15mm, dy=15mm

Maximum value of SAR (interpolated) = 0.000 mW/g

Ch384/Zoom Scan (5x5x7)/Cube 0: Measurement grid: dx=8mm, dy=8mm, dz=5mm

Reference Value = 0.295 V/m; Power Drift = -0.155 dB

Peak SAR (extrapolated) = 0.000 W/kg

SAR(1 g) = 3.83e-006 mW/g; SAR(10 g) = 5.47e-007 mW/g

Maximum value of SAR (measured) = 0.001 mW/g

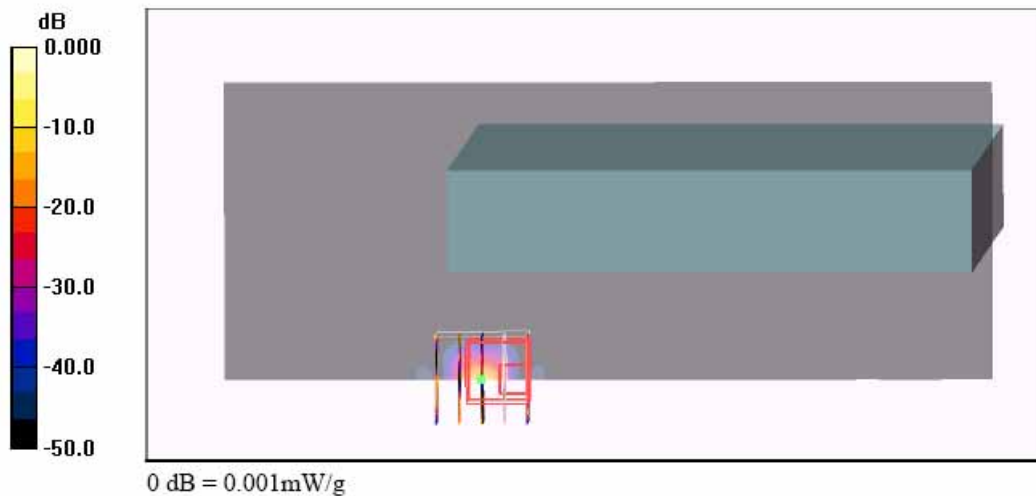

Test Laboratory: Sporton International Inc. SAR/HAC Testing Lab

Date: 2007/12/20

Body_CDMA2000 Ch384_Right Side with 0cm Gap_1xRTT_FCH-RC1_Ant Extend

DUT: 7N3014

Communication System: CDMA ; Frequency: 836.52 MHz;Duty Cycle: 1:1

Medium: MSL_850 Medium parameters used: $f = 837 \text{ MHz}$; $\sigma = 0.971 \text{ mho/m}$; $\epsilon_r = 55.1$; $\rho = 1000 \text{ kg/m}^3$

Ambient Temperature : 21.7 °C; Liquid Temperature : 21.2 °C

DASY4 Configuration:

- Probe: ET3DV6 - SN1787; ConvF(6.1, 6.1, 6.1); Calibrated: 2007/8/28
- Sensor-Surface: 4mm (Mechanical Surface Detection)
- Electronics: DAE4 Sn778; Calibrated: 2007/9/17
- Phantom: ELI 4.0; Type: QDOVA001BA; Serial: 1029
- Measurement SW: DASY4, V4.7 Build 55; Postprocessing SW: SEMCAD, V1.8 Build 176

Ch384/Area Scan (71x181x1): Measurement grid: dx=15mm, dy=15mm

Maximum value of SAR (interpolated) = 0.040 mW/g

Ch384/Zoom Scan (5x5x7)/Cube 0: Measurement grid: dx=8mm, dy=8mm, dz=5mm

Reference Value = 5.28 V/m; Power Drift = 0.093 dB

Peak SAR (extrapolated) = 0.077 W/kg

SAR(1 g) = 0.038 mW/g; SAR(10 g) = 0.023 mW/g

Maximum value of SAR (measured) = 0.043 mW/g

Ch384/Zoom Scan (5x5x7)/Cube 1: Measurement grid: dx=8mm, dy=8mm, dz=5mm

Reference Value = 5.28 V/m; Power Drift = 0.093 dB

Peak SAR (extrapolated) = 0.032 W/kg

SAR(1 g) = 0.024 mW/g; SAR(10 g) = 0.017 mW/g

Maximum value of SAR (measured) = 0.025 mW/g

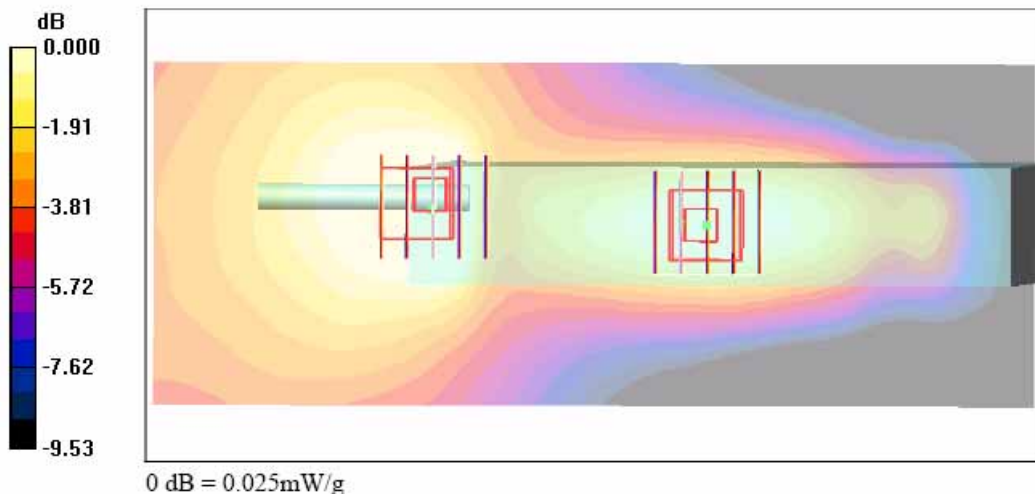

Test Laboratory: Sporton International Inc. SAR/HAC Testing Lab

Date: 2007/12/20

Body_CDMA2000 Ch384_Left Side with 0cm Gap_1xRTT_FCH-RC1_Ant Retract

DUT: 7N3014

Communication System: CDMA ; Frequency: 836.52 MHz; Duty Cycle: 1:1

Medium: MSL_850 Medium parameters used: $f = 837$ MHz; $\sigma = 0.971$ mho/m; $\epsilon_r = 55.1$; $\rho = 1000$ kg/m³

Ambient Temperature : 22.0 °C; Liquid Temperature : 21.2 °C

DASY4 Configuration:

- Probe: ET3DV6 - SN1787; ConvF(6.1, 6.1, 6.1); Calibrated: 2007/8/28
- Sensor-Surface: 4mm (Mechanical Surface Detection)
- Electronics: DAE4 Sn778; Calibrated: 2007/9/17
- Phantom: ELI 4.0; Type: QDOVA001BA; Serial: 1029
- Measurement SW: DASY4, V4.7 Build 55; Postprocessing SW: SEMCAD, V1.8 Build 176

Ch384/Area Scan (71x181x1): Measurement grid: dx=15mm, dy=15mm

Maximum value of SAR (interpolated) = 0.003 mW/g

Ch384/Zoom Scan (5x5x7)/Cube 0: Measurement grid: dx=8mm, dy=8mm, dz=5mm

Reference Value = 1.29 V/m; Power Drift = -0.175 dB

Peak SAR (extrapolated) = 0.003 W/kg

SAR(1 g) = 0.00211 mW/g; SAR(10 g) = 0.00106 mW/g

Maximum value of SAR (measured) = 0.002 mW/g

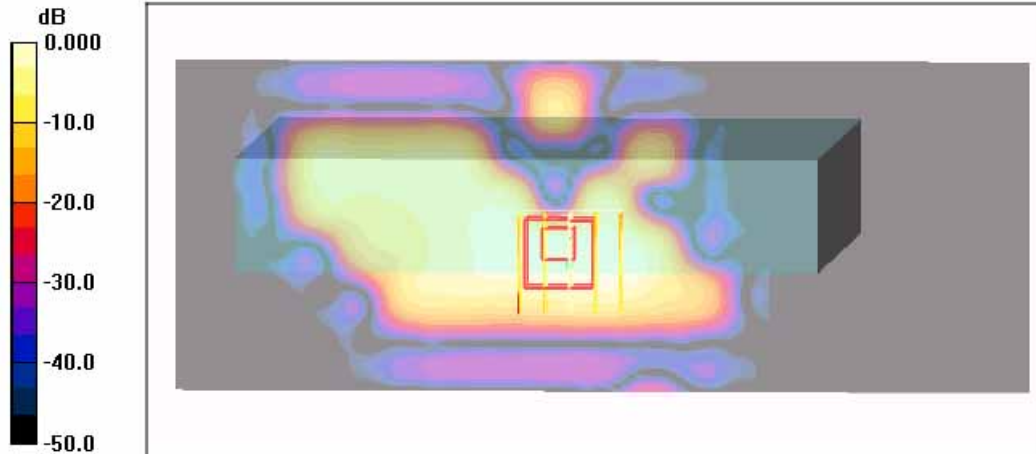

0 dB = 0.002mW/g

Test Laboratory: Sporton International Inc. SAR/HAC Testing Lab

Date/Time: 2007/12/20

Body_CDMA2000 Ch384_Left Side with 0cm Gap_1xRTT_FCH-RC1_Ant Extend

DUT: 7N3014

Communication System: CDMA ; Frequency: 836.52 MHz;Duty Cycle: 1:1

Medium: MSL_850 Medium parameters used: $f = 837$ MHz; $\sigma = 0.971$ mho/m; $\epsilon_r = 55.1$; $\rho = 1000$ kg/m³

Ambient Temperature : 21.7 °C; Liquid Temperature : 21.2 °C

DASY4 Configuration:

- Probe: ET3DV6 - SN1787; ConvF(6.1, 6.1, 6.1); Calibrated: 2007/8/28
- Sensor-Surface: 4mm (Mechanical Surface Detection)
- Electronics: DAE4 Sn778; Calibrated: 2007/9/17
- Phantom: ELI 4.0; Type: QDOVA001BA; Serial: 1029
- Measurement SW: DASY4, V4.7 Build 55; Postprocessing SW: SEMCAD, V1.8 Build 176

Ch384/Area Scan (71x181x1): Measurement grid: dx=15mm, dy=15mm

Maximum value of SAR (interpolated) = 0.580 mW/g

Ch384/Zoom Scan (5x5x7)/Cube 0: Measurement grid: dx=8mm, dy=8mm, dz=5mm

Reference Value = 8.07 V/m; Power Drift = 0.052 dB

Peak SAR (extrapolated) = 0.806 W/kg

SAR(1 g) = 0.544 mW/g; SAR(10 g) = 0.368 mW/g

Maximum value of SAR (measured) = 0.576 mW/g

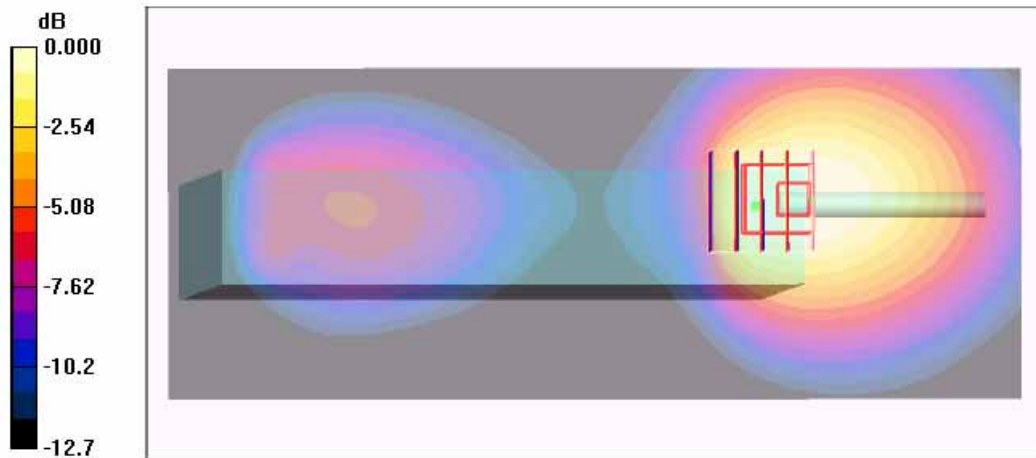

0 dB = 0.576mW/g

Test Laboratory: Sporton International Inc. SAR/HAC Testing Lab

Date: 2007/12/20

Body_CDMA2000 Ch600_Front Face with 0cm Gap_1xRTT_FCH-RC1_Ant Retract

DUT: 7N3014

Communication System: CDMA ; Frequency: 1880 MHz;Duty Cycle: 1:1

Medium: MSL_1900 Medium parameters used: f = 1880 MHz; $\sigma = 1.54$ mho/m; $\epsilon_r = 51.8$; $\rho = 1000$ kg/m³

Ambient Temperature : 22.9 °C; Liquid Temperature : 21.6 °C

DASY4 Configuration:

- Probe: ET3DV6 - SN1787; ConvF(4.68, 4.68, 4.68); Calibrated: 2007/8/28
- Sensor-Surface: 4mm (Mechanical Surface Detection)
- Electronics: DAE4 Sn778; Calibrated: 2007/9/17
- Phantom: ELI 4.0; Type: QDOVA001BA; Serial: 1029
- Measurement SW: DASY4, V4.7 Build 55; Postprocessing SW: SEMCAD, V1.8 Build 176

Ch600/Area Scan (161x211x1): Measurement grid: dx=15mm, dy=15mm

Maximum value of SAR (interpolated) = 0.010 mW/g

Ch600/Zoom Scan (5x5x7)/Cube 0: Measurement grid: dx=8mm, dy=8mm, dz=5mm

Reference Value = 0.337 V/m; Power Drift = -0.187 dB

Peak SAR (extrapolated) = 0.008 W/kg

SAR(1 g) = 0.00507 mW/g; SAR(10 g) = 0.00266 mW/g

Maximum value of SAR (measured) = 0.005 mW/g

Ch600/Zoom Scan (5x5x7)/Cube 1: Measurement grid: dx=8mm, dy=8mm, dz=5mm

Reference Value = 0.337 V/m; Power Drift = -0.187 dB

Peak SAR (extrapolated) = 0.011 W/kg

SAR(1 g) = 0.00357 mW/g; SAR(10 g) = 0.00124 mW/g

Maximum value of SAR (measured) = 0.003 mW/g

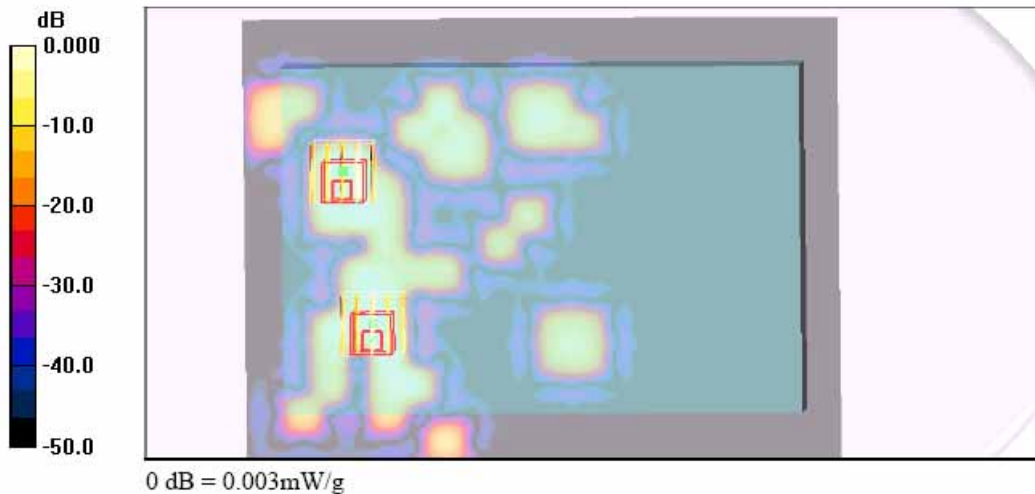

Test Laboratory: Sporton International Inc. SAR/HAC Testing Lab

Date: 2007/12/20

Body_CDMA2000 Ch600_Front Face with 0cm Gap_1xRTT_FCH-RC1_Ant Extend

DUT: 7N3014

Communication System: CDMA ; Frequency: 1880 MHz; Duty Cycle: 1:1

Medium: MSL_1900 Medium parameters used: $f = 1880$ MHz; $\sigma = 1.54$ mho/m; $\epsilon_r = 51.8$; $\rho = 1000$ kg/m³

Ambient Temperature : 22.9 °C; Liquid Temperature : 21.6 °C

DASY4 Configuration:

- Probe: ET3DV6 - SN1787; ConvF(4.68, 4.68, 4.68); Calibrated: 2007/8/28
- Sensor-Surface: 4mm (Mechanical Surface Detection)
- Electronics: DAE4 Sn778; Calibrated: 2007/9/17
- Phantom: ELI 4.0; Type: QDOVA001BA; Serial: 1029
- Measurement SW: DASY4, V4.7 Build 55; Postprocessing SW: SEMCAD, V1.8 Build 176

Ch600/Area Scan (181x211x1): Measurement grid: dx=15mm, dy=15mm

Maximum value of SAR (interpolated) = 0.186 mW/g

Ch600/Zoom Scan (5x5x7)/Cube 0: Measurement grid: dx=8mm, dy=8mm, dz=5mm

Reference Value = 0.995 V/m; Power Drift = -0.142 dB

Peak SAR (extrapolated) = 0.254 W/kg

SAR(1 g) = 0.168 mW/g; SAR(10 g) = 0.108 mW/g

Maximum value of SAR (measured) = 0.181 mW/g

Ch600/Zoom Scan (5x5x7)/Cube 1: Measurement grid: dx=8mm, dy=8mm, dz=5mm

Reference Value = 0.995 V/m; Power Drift = -0.142 dB

Peak SAR (extrapolated) = 0.231 W/kg

SAR(1 g) = 0.145 mW/g; SAR(10 g) = 0.092 mW/g

Maximum value of SAR (measured) = 0.167 mW/g

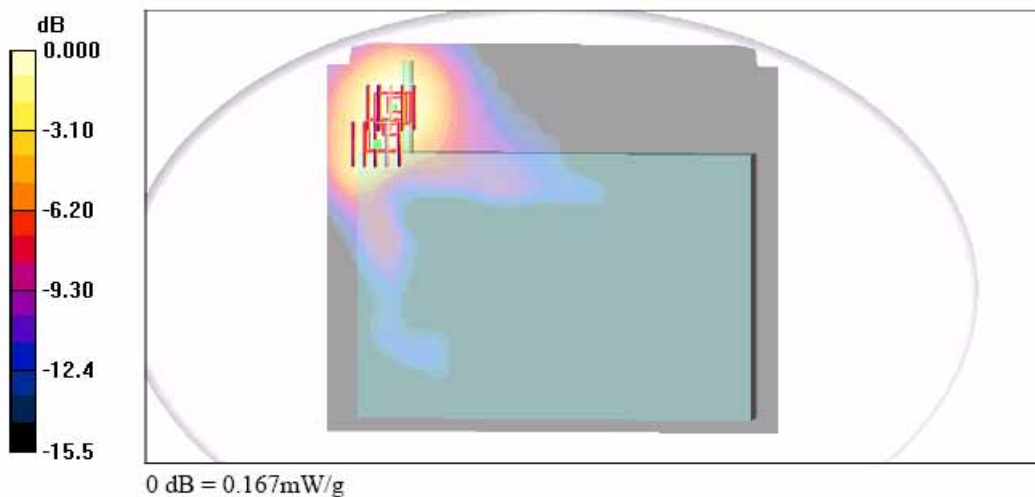

Test Laboratory: Sporton International Inc. SAR/HAC Testing Lab

Date: 2007/12/21

Body_CDMA2000 Ch600_Rear Face with 0cm Gap_1xRTT_FCH-RC1_Ant Extend_for E100

DUT: 7N3014

Communication System: CDMA ; Frequency: 1880 MHz;Duty Cycle: 1:1

Medium: MSL_1900 Medium parameters used: $f = 1880$ MHz; $\sigma = 1.54$ mho/m; $\epsilon_r = 51.8$; $\rho = 1000$ kg/m³

Ambient Temperature : 22.8 °C; Liquid Temperature : 21.2 °C

DASY4 Configuration:

- Probe: ET3DV6 - SN1787; ConvF(4.68, 4.68, 4.68); Calibrated: 2007/8/28
- Sensor-Surface: 4mm (Mechanical Surface Detection)
- Electronics: DAE4 Sn778; Calibrated: 2007/9/17
- Phantom: ELI 4.0; Type: QDOVA001BA; Serial: 1029
- Measurement SW: DASY4, V4.7 Build 55; Postprocessing SW: SEMCAD, V1.8 Build 176

Ch600/Area Scan (61x51x1): Measurement grid: dx=15mm, dy=15mm

Maximum value of SAR (interpolated) = 1.61 mW/g

Ch600/Zoom Scan (5x5x7)/Cube 0: Measurement grid: dx=8mm, dy=8mm, dz=5mm

Reference Value = 0.892 V/m; Power Drift = 0.142 dB

Peak SAR (extrapolated) = 1.92 W/kg

SAR(1 g) = 1.22 mW/g; SAR(10 g) = 0.682 mW/g

Maximum value of SAR (measured) = 1.36 mW/g

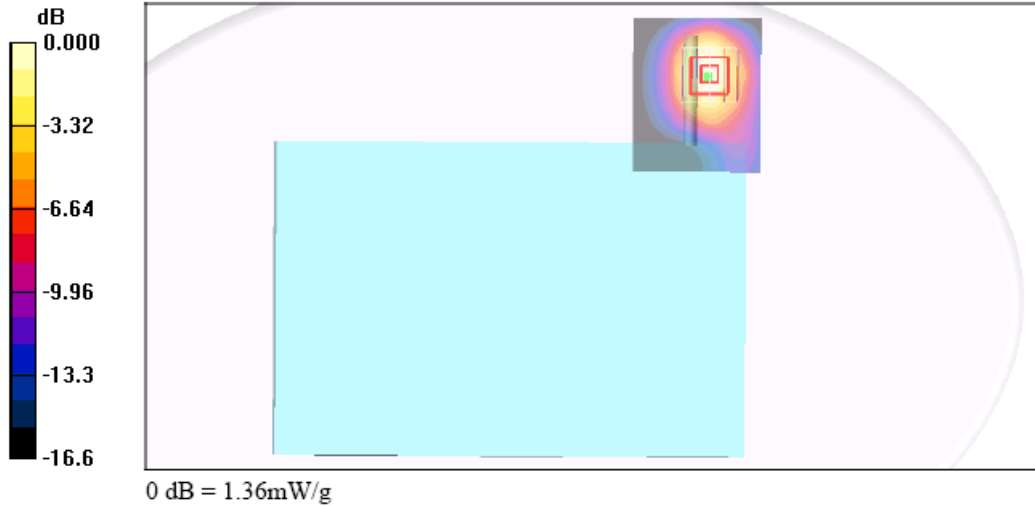

Test Laboratory: Sporton International Inc. SAR/HAC Testing Lab

Date : 2007/12/20

Body_CDMA2000 Ch600_Rear Face with 0cm Gap_1xRTT_FCH-RC1_Ant Retract

DUT: 7N3014

Communication System: CDMA ; Frequency: 1880 MHz;Duty Cycle: 1:1

Medium: MSL_1900 Medium parameters used: $f = 1880$ MHz; $\sigma = 1.54$ mho/m; $\epsilon_r = 51.8$; $\rho = 1000$ kg/m³

Ambient Temperature : 22.9 °C ; Liquid Temperature : 21.6 °C

DASY4 Configuration:

- Probe: ET3DV6 - SN1787; ConvF(4.68, 4.68, 4.68); Calibrated: 2007/8/28
- Sensor-Surface: 4mm (Mechanical Surface Detection)
- Electronics: DAE4 Sn778; Calibrated: 2007/9/17
- Phantom: ELI 4.0; Type: QDOVA001BA; Serial: 1029
- Measurement SW: DASY4, V4.7 Build 55; Postprocessing SW: SEMCAD, V1.8 Build 176

Ch600/Area Scan (161x211x1): Measurement grid: dx=15mm, dy=15mm

Maximum value of SAR (interpolated) = 0.020 mW/g

Ch600/Zoom Scan (5x5x7)/Cube 0: Measurement grid: dx=8mm, dy=8mm, dz=5mm

Reference Value = 0.162 V/m; Power Drift = -0.111 dB

Peak SAR (extrapolated) = 0.017 W/kg

SAR(1 g) = 0.00911 mW/g; SAR(10 g) = 0.00479 mW/g

Maximum value of SAR (measured) = 0.010 mW/g

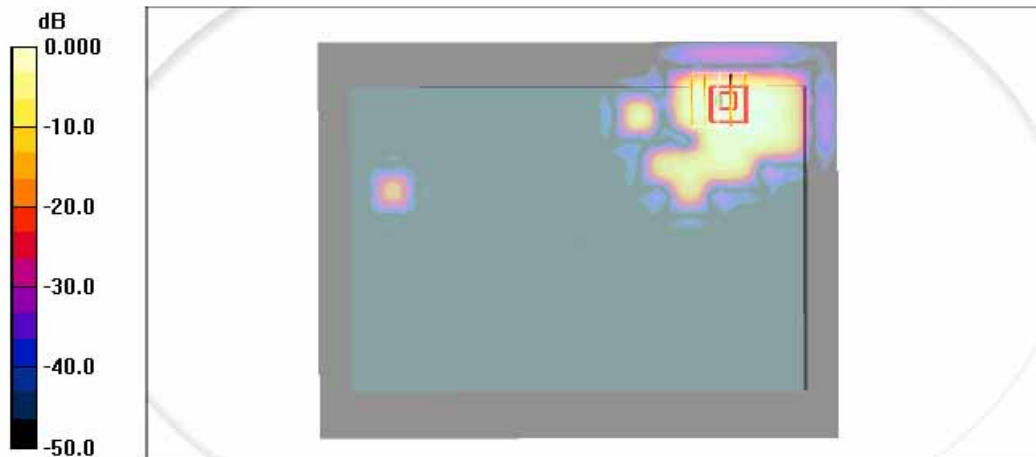

0 dB = 0.010mW/g

Test Laboratory: Sporton International Inc. SAR/HAC Testing Lab

Date: 2007/12/20

Body_CDMA2000 Ch600_Rear Face with 0cm Gap_1xRTT_FCH-RC1_Ant Extend

DUT: 7N3014

Communication System: CDMA ; Frequency: 1880 MHz;Duty Cycle: 1:1

Medium: MSL_1900 Medium parameters used: $f = 1880$ MHz; $\sigma = 1.54$ mho/m; $\epsilon_r = 51.8$; $\rho = 1000$ kg/m³

Ambient Temperature : 22.9 °C ; Liquid Temperature : 21.6 °C

DASY4 Configuration:

- Probe: ET3DV6 - SN1787; ConvF(4.68, 4.68, 4.68); Calibrated: 2007/8/28
- Sensor-Surface: 4mm (Mechanical Surface Detection)
- Electronics: DAE4 Sn778; Calibrated: 2007/9/17
- Phantom: ELI 4.0; Type: QDOVA001BA; Serial: 1029
- Measurement SW: DASY4, V4.7 Build 55; Postprocessing SW: SEMCAD, V1.8 Build 176

Ch600/Area Scan (181x211x1): Measurement grid: dx=15mm, dy=15mm

Maximum value of SAR (interpolated) = 1.35 mW/g

Ch600/Zoom Scan (5x5x7)/Cube 0: Measurement grid: dx=8mm, dy=8mm, dz=5mm

Reference Value = 1.03 V/m; Power Drift = -0.145 dB

Peak SAR (extrapolated) = 1.89 W/kg

SAR(1 g) = 1.16 mW/g; SAR(10 g) = 0.658 mW/g

Maximum value of SAR (measured) = 1.29 mW/g

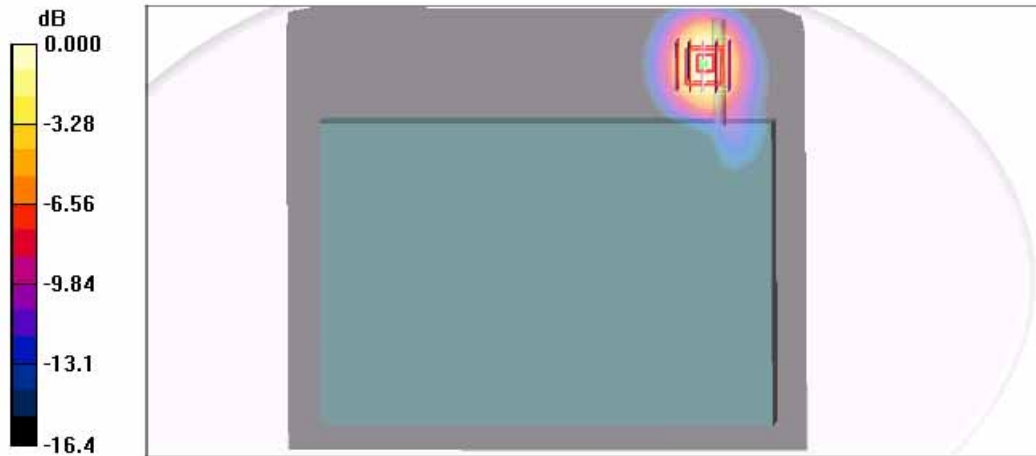

0 dB = 1.29mW/g

Test Laboratory: Sporton International Inc. SAR/HAC Testing Lab

Date: 2007/12/21

Body_CDMA2000 Ch600_Rear Face with 0cm Gap_1xRTT_FCH-RC3_Ant Extend

DUT: 7N3014

Communication System: CDMA ; Frequency: 1880 MHz;Duty Cycle: 1:1

Medium: MSL_1900 Medium parameters used: $f = 1880 \text{ MHz}$; $\sigma = 1.54 \text{ mho/m}$; $\epsilon_r = 51.8$; $\rho = 1000 \text{ kg/m}^3$

Ambient Temperature : 22.8 °C; Liquid Temperature : 21.6 °C

DASY4 Configuration:

- Probe: ET3DV6 - SN1787; ConvF(4.68, 4.68, 4.68); Calibrated: 2007/8/28
- Sensor-Surface: 4mm (Mechanical Surface Detection)
- Electronics: DAE4 Sn778; Calibrated: 2007/9/17
- Phantom: ELI 4.0; Type: QDOVA001BA; Serial: 1029
- Measurement SW: DASY4, V4.7 Build 55; Postprocessing SW: SEMCAD, V1.8 Build 176

Ch600/Area Scan (101x101x1): Measurement grid: dx=15mm, dy=15mm

Maximum value of SAR (interpolated) = 1.36 mW/g

Ch600/Zoom Scan (5x5x7)/Cube 0: Measurement grid: dx=8mm, dy=8mm, dz=5mm

Reference Value = 0.358 V/m; Power Drift = -0.108 dB

Peak SAR (extrapolated) = 1.79 W/kg

SAR(1 g) = 1.1 mW/g; SAR(10 g) = 0.616 mW/g

Maximum value of SAR (measured) = 1.21 mW/g

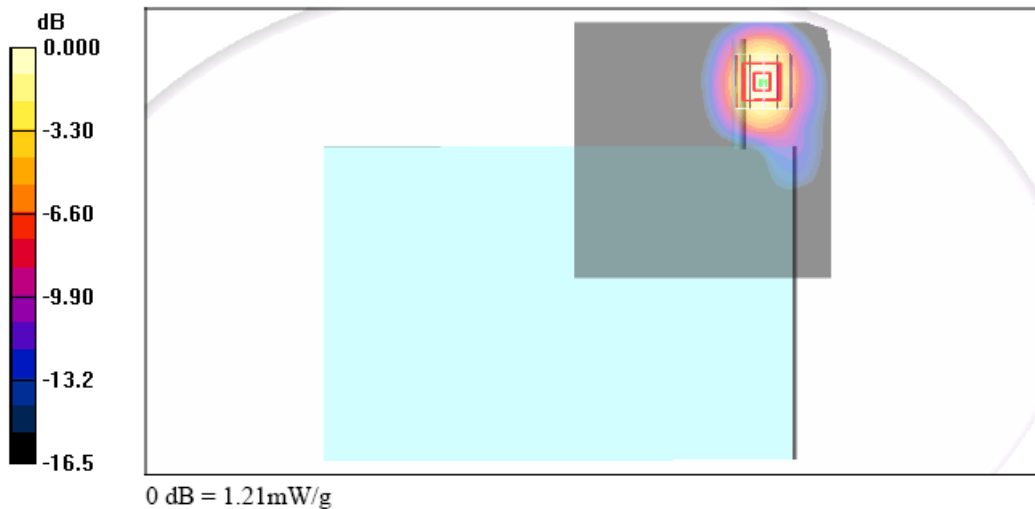

Test Laboratory: Sporton International Inc. SAR/HAC Testing Lab

Date: 2007/12/21

Body_CDMA2000 Ch600_Rear Face with 0cm Gap_1xRTT_FCH+SCH-RC3_Ant Extend

DUT: 7N3014

Communication System: CDMA ; Frequency: 1880 MHz;Duty Cycle: 1:1

Medium: MSL_1900 Medium parameters used: $f = 1880$ MHz; $\sigma = 1.54$ mho/m; $\epsilon_r = 51.8$; $\rho = 1000$ kg/m³

Ambient Temperature : 22.8 °C; Liquid Temperature : 21.6 °C

DASY4 Configuration:

- Probe: ET3DV6 - SN1787; ConvF(4.68, 4.68, 4.68); Calibrated: 2007/8/28
- Sensor-Surface: 4mm (Mechanical Surface Detection)
- Electronics: DAE4 Sn778; Calibrated: 2007/9/17
- Phantom: ELI 4.0; Type: QDOVA001BA; Serial: 1029
- Measurement SW: DASY4, V4.7 Build 55; Postprocessing SW: SEMCAD, V1.8 Build 176

Ch600/Area Scan (101x101x1): Measurement grid: dx=15mm, dy=15mm

Maximum value of SAR (interpolated) = 1.33 mW/g

Ch600/Zoom Scan (5x5x7)/Cube 0: Measurement grid: dx=8mm, dy=8mm, dz=5mm

Reference Value = 0.467 V/m; Power Drift = -0.178 dB

Peak SAR (extrapolated) = 1.75 W/kg

SAR(1 g) = 1.09 mW/g; SAR(10 g) = 0.610 mW/g

Maximum value of SAR (measured) = 1.20 mW/g

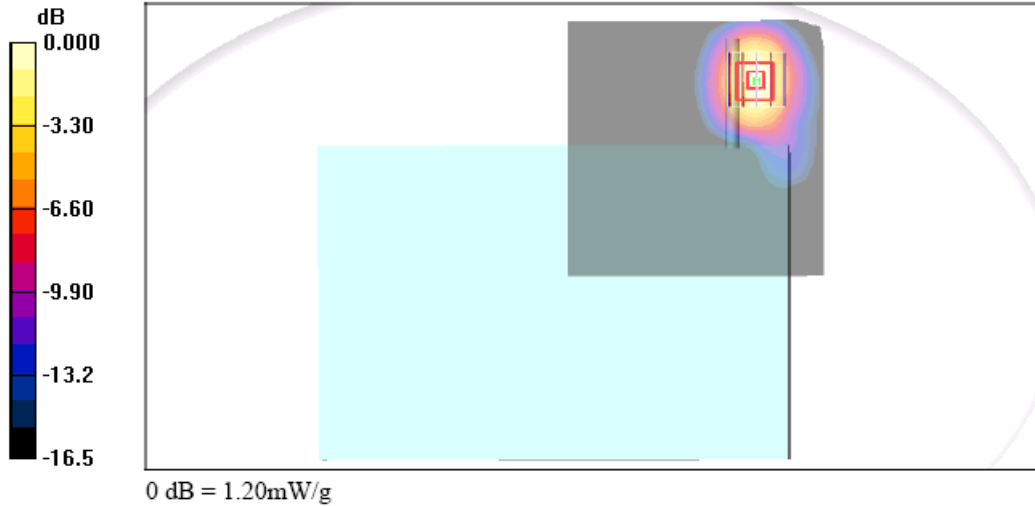

Test Laboratory: Sporton International Inc. SAR/HAC Testing Lab

Date: 2007/12/21

Body_CDMA2000 Ch600_Rear Face with 0cm Gap_1xEVDO_Rev0_RTAP_9.6K_Ant Extend

DUT: 7N3014

Communication System: CDMA ; Frequency: 1880 MHz;Duty Cycle: 1:1

Medium: MSL_1900 Medium parameters used: f = 1880 MHz; $\sigma = 1.54$ mho/m; $\epsilon_r = 51.8$; $\rho = 1000$ kg/m³

Ambient Temperature : 22.9 °C; Liquid Temperature : 21.6 °C

DASY4 Configuration:

- Probe: ET3DV6 - SN1787; ConvF(4.68, 4.68, 4.68); Calibrated: 2007/8/28
- Sensor-Surface: 4mm (Mechanical Surface Detection)
- Electronics: DAE4 Sn778; Calibrated: 2007/9/17
- Phantom: ELI 4.0; Type: QDOVA001BA; Serial: 1029
- Measurement SW: DASY4, V4.7 Build 55; Postprocessing SW: SEMCAD, V1.8 Build 176

Ch600/Area Scan (101x101x1): Measurement grid: dx=15mm, dy=15mm

Maximum value of SAR (interpolated) = 1.40 mW/g

Ch600/Zoom Scan (5x5x7)/Cube 0: Measurement grid: dx=8mm, dy=8mm, dz=5mm

Reference Value = 0.616 V/m; Power Drift = -0.168 dB

Peak SAR (extrapolated) = 1.78 W/kg

SAR(1 g) = 1.11 mW/g; SAR(10 g) = 0.620 mW/g

Maximum value of SAR (measured) = 1.23 mW/g

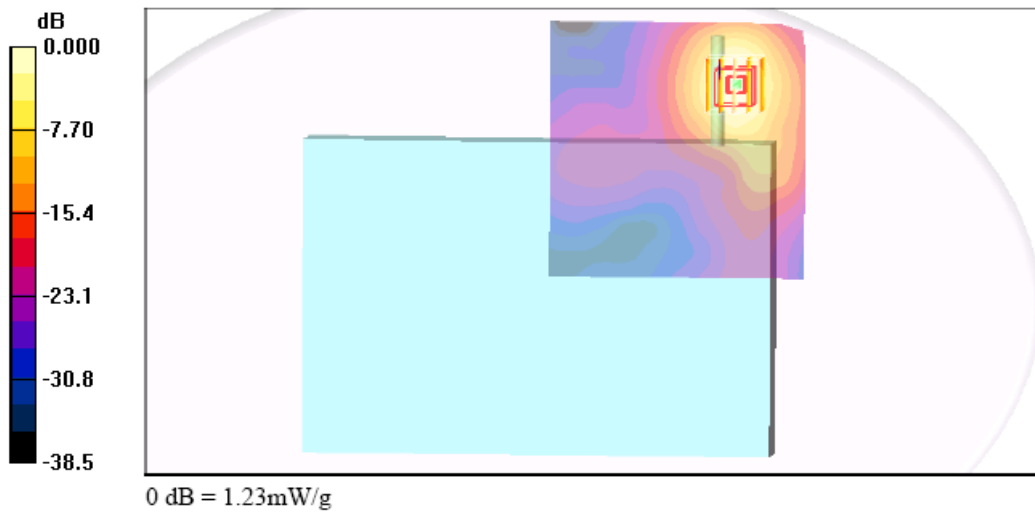

Test Laboratory: Sporton International Inc. SAR/HAC Testing Lab

Date: 2007/12/21

Body_CDMA2000 Ch600_Rear Face with 0cm Gap_1xEVDO_Rev0_RTAP_38.4K_Ant Extend**DUT: 7N3014**

Communication System: CDMA ; Frequency: 1880 MHz;Duty Cycle: 1:1

Medium: MSL_1900 Medium parameters used: $f = 1880$ MHz; $\sigma = 1.54$ mho/m; $\epsilon_r = 51.8$; $\rho = 1000$ kg/m³

Ambient Temperature : 22.8 °C; Liquid Temperature : 21.6 °C

DASY4 Configuration:

- Probe: ET3DV6 - SN1787; ConvF(4.68, 4.68, 4.68); Calibrated: 2007/8/28
- Sensor-Surface: 4mm (Mechanical Surface Detection)
- Electronics: DAE4 Sn778; Calibrated: 2007/9/17
- Phantom: ELI 4.0; Type: QDOVA001BA; Serial: 1029
- Measurement SW: DASY4, V4.7 Build 55; Postprocessing SW: SEMCAD, V1.8 Build 176

Ch600/Area Scan (101x101x1): Measurement grid: dx=15mm, dy=15mm

Maximum value of SAR (interpolated) = 1.30 mW/g

Ch600/Zoom Scan (5x5x7)/Cube 0: Measurement grid: dx=8mm, dy=8mm, dz=5mm

Reference Value = 0.444 V/m; Power Drift = 0.127 dB

Peak SAR (extrapolated) = 1.77 W/kg

SAR(1 g) = 1.07 mW/g; SAR(10 g) = 0.594 mW/g

Maximum value of SAR (measured) = 1.19 mW/g

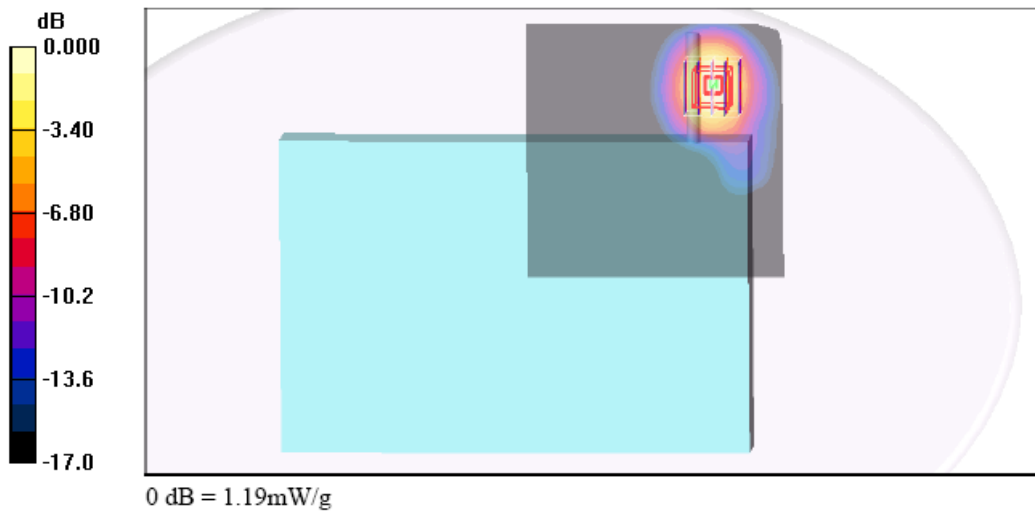

Test Laboratory: Sporton International Inc. SAR/HAC Testing Lab

Date: 2007/12/21

Body_CDMA2000 Ch600_Rear Face with 0cm Gap_1xEVDO_Rev0_RTAP_153.6K_Ant Extend

DUT: 7N3014

Communication System: CDMA ; Frequency: 1880 MHz;Duty Cycle: 1:1

Medium: MSL_1900 Medium parameters used: $f = 1880$ MHz; $\sigma = 1.54$ mho/m; $\epsilon_r = 51.8$; $\rho = 1000$ kg/m³

Ambient Temperature : 22.8 °C; Liquid Temperature : 21.6 °C

DASY4 Configuration:

- Probe: ET3DV6 - SN1787; ConvF(4.68, 4.68, 4.68); Calibrated: 2007/8/28
- Sensor-Surface: 4mm (Mechanical Surface Detection)
- Electronics: DAE4 Sn778; Calibrated: 2007/9/17
- Phantom: ELI 4.0; Type: QDOVA001BA; Serial: 1029
- Measurement SW: DASY4, V4.7 Build 55; Postprocessing SW: SEMCAD, V1.8 Build 176

Ch600/Area Scan (101x101x1): Measurement grid: dx=15mm, dy=15mm

Maximum value of SAR (interpolated) = 1.13 mW/g

Ch600/Zoom Scan (5x5x7)/Cube 0: Measurement grid: dx=8mm, dy=8mm, dz=5mm

Reference Value = 0.263 V/m; Power Drift = 0.184 dB

Peak SAR (extrapolated) = 1.59 W/kg

SAR(1 g) = 0.994 mW/g; SAR(10 g) = 0.566 mW/g

Maximum value of SAR (measured) = 1.07 mW/g

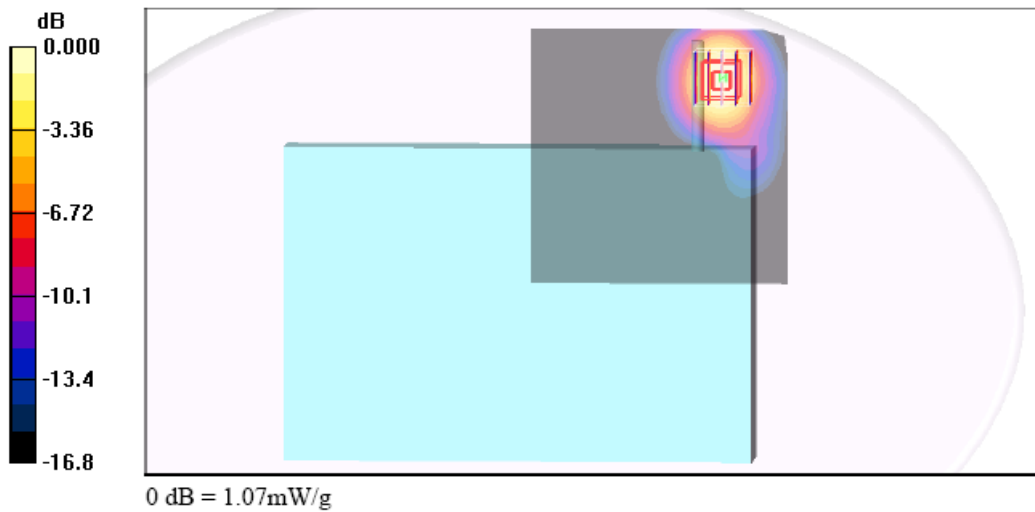

Test Laboratory: Sporton International Inc. SAR/HAC Testing Lab

Date: 2007/12/21

Body_CDMA2000 Ch600_Rear Face with 0cm Gap_1xEVDO_RevA_RETAP_128_Ant Extend**DUT: 7N3014**

Communication System: CDMA ; Frequency: 1880 MHz;Duty Cycle: 1:1

Medium: MSL_1900 Medium parameters used: $f = 1880$ MHz; $\sigma = 1.54$ mho/m; $\epsilon_r = 51.8$; $\rho = 1000$ kg/m³

Ambient Temperature : 22.8 °C; Liquid Temperature : 21.6 °C

DASY4 Configuration:

- Probe: ET3DV6 - SN1787; ConvF(4.68, 4.68, 4.68); Calibrated: 2007/8/28
- Sensor-Surface: 4mm (Mechanical Surface Detection)
- Electronics: DAE4 Sn778; Calibrated: 2007/9/17
- Phantom: ELI 4.0; Type: QDOVA001BA; Serial: 1029
- Measurement SW: DASY4, V4.7 Build 55; Postprocessing SW: SEMCAD, V1.8 Build 176

Ch600/Area Scan (101x101x1): Measurement grid: dx=15mm, dy=15mm

Maximum value of SAR (interpolated) = 1.26 mW/g

Ch600/Zoom Scan (5x5x7)/Cube 0: Measurement grid: dx=8mm, dy=8mm, dz=5mm

Reference Value = 0.562 V/m; Power Drift = 0.181 dB

Peak SAR (extrapolated) = 1.75 W/kg

SAR(1 g) = 1.06 mW/g; SAR(10 g) = 0.588 mW/g

Maximum value of SAR (measured) = 1.12 mW/g

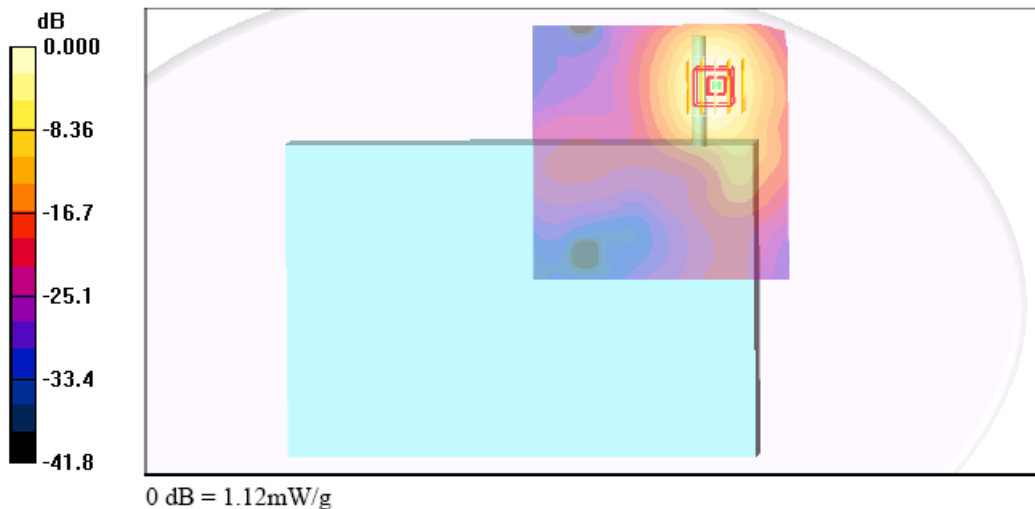

Test Laboratory: Sporton International Inc. SAR/HAC Testing Lab

Date: 2007/12/21

Body_CDMA2000 Ch600_Rear Face with 0cm Gap_1xEVDO_RevA_RETAP_2048_Ant Extend

DUT: 7N3014

Communication System: CDMA ; Frequency: 1880 MHz;Duty Cycle: 1:1

Medium: MSL_1900 Medium parameters used: $f = 1880$ MHz; $\sigma = 1.54$ mho/m; $\epsilon_r = 51.8$; $\rho = 1000$ kg/m³

Ambient Temperature : 22.7 °C; Liquid Temperature : 21.6 °C

DASY4 Configuration:

- Probe: ET3DV6 - SN1787; ConvF(4.68, 4.68, 4.68); Calibrated: 2007/8/28
- Sensor-Surface: 4mm (Mechanical Surface Detection)
- Electronics: DAE4 Sn778; Calibrated: 2007/9/17
- Phantom: ELI 4.0; Type: QDOVA001BA; Serial: 1029
- Measurement SW: DASY4, V4.7 Build 55; Postprocessing SW: SEMCAD, V1.8 Build 176

Ch600/Area Scan (101x101x1): Measurement grid: dx=15mm, dy=15mm

Maximum value of SAR (interpolated) = 1.22 mW/g

Ch600/Zoom Scan (5x5x7)/Cube 0: Measurement grid: dx=8mm, dy=8mm, dz=5mm

Reference Value = 0.381 V/m; Power Drift = -0.131 dB

Peak SAR (extrapolated) = 1.89 W/kg

SAR(1 g) = 1.03 mW/g; SAR(10 g) = 0.582 mW/g

Maximum value of SAR (measured) = 1.13 mW/g

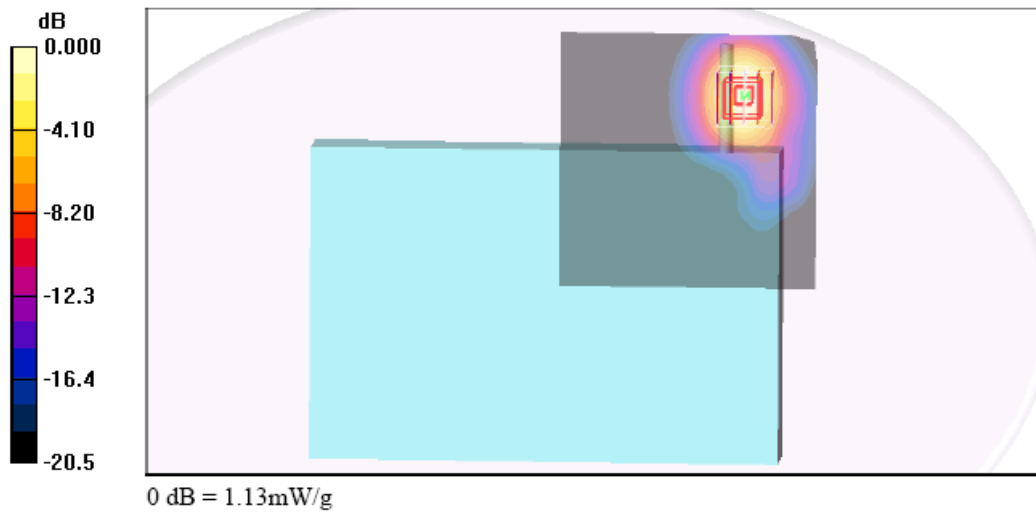

Test Laboratory: Sporton International Inc. SAR/HAC Testing Lab

Date: 2007/12/21

Body_CDMA2000 Ch600_Rear Face with 0cm Gap_1xEVDO_RevA_RETAP_12288_Ant Extend

DUT: 7N3014

Communication System: CDMA ; Frequency: 1880 MHz;Duty Cycle: 1:1

Medium: MSL_1900 Medium parameters used: $f = 1880 \text{ MHz}$; $\sigma = 1.54 \text{ mho/m}$; $\epsilon_r = 51.8$; $\rho = 1000 \text{ kg/m}^3$

Ambient Temperature : 22.8 °C; Liquid Temperature : 21.6 °C

DASY4 Configuration:

- Probe: ET3DV6 - SN1787; ConvF(4.68, 4.68, 4.68); Calibrated: 2007/8/28
- Sensor-Surface: 4mm (Mechanical Surface Detection)
- Electronics: DAE4 Sn778; Calibrated: 2007/9/17
- Phantom: ELI 4.0; Type: QDOVA001BA; Serial: 1029
- Measurement SW: DASY4, V4.7 Build 55; Postprocessing SW: SEMCAD, V1.8 Build 176

Ch600/Area Scan (101x101x1): Measurement grid: dx=15mm, dy=15mm

Maximum value of SAR (interpolated) = 1.22 mW/g

Ch600/Zoom Scan (5x5x7)/Cube 0: Measurement grid: dx=8mm, dy=8mm, dz=5mm

Reference Value = 0.420 V/m; Power Drift = 0.179 dB

Peak SAR (extrapolated) = 1.64 W/kg

SAR(1 g) = 1.02 mW/g; SAR(10 g) = 0.570 mW/g

Maximum value of SAR (measured) = 1.12 mW/g

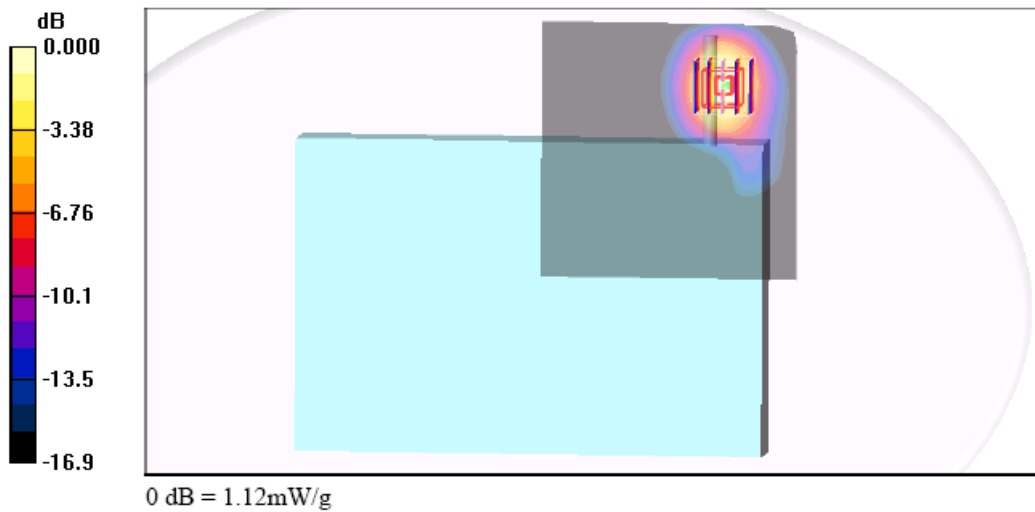

Test Laboratory: Sporton International Inc. SAR/HAC Testing Lab

Date: 2007/12/21

Body_CDMA2000 Ch600_Top Side with 0cm Gap_1xRTT_FCH-RC1_Ant Retract

DUT: 7N3014

Communication System: CDMA ; Frequency: 1880 MHz;Duty Cycle: 1:1

Medium: MSL_1900 Medium parameters used: $f = 1880$ MHz; $\sigma = 1.54$ mho/m; $\epsilon_r = 51.8$; $\rho = 1000$ kg/m³

Ambient Temperature : 22.9 °C; Liquid Temperature : 21.6 °C

DASY4 Configuration:

- Probe: ET3DV6 - SN1787; ConvF(4.68, 4.68, 4.68); Calibrated: 2007/8/28
- Sensor-Surface: 4mm (Mechanical Surface Detection)
- Electronics: DAE4 Sn778; Calibrated: 2007/9/17
- Phantom: ELI 4.0; Type: QDOVA001BA; Serial: 1029
- Measurement SW: DASY4, V4.7 Build 55; Postprocessing SW: SEMCAD, V1.8 Build 176

Ch600/Area Scan (71x201x1): Measurement grid: dx=15mm, dy=15mm

Maximum value of SAR (interpolated) = 0.025 mW/g

Ch600/Zoom Scan (5x5x7)/Cube 0: Measurement grid: dx=8mm, dy=8mm, dz=5mm

Reference Value = 1.38 V/m; Power Drift = -0.121 dB

Peak SAR (extrapolated) = 0.063 W/kg

SAR(1 g) = 0.026 mW/g; SAR(10 g) = 0.012 mW/g

Maximum value of SAR (measured) = 0.026 mW/g

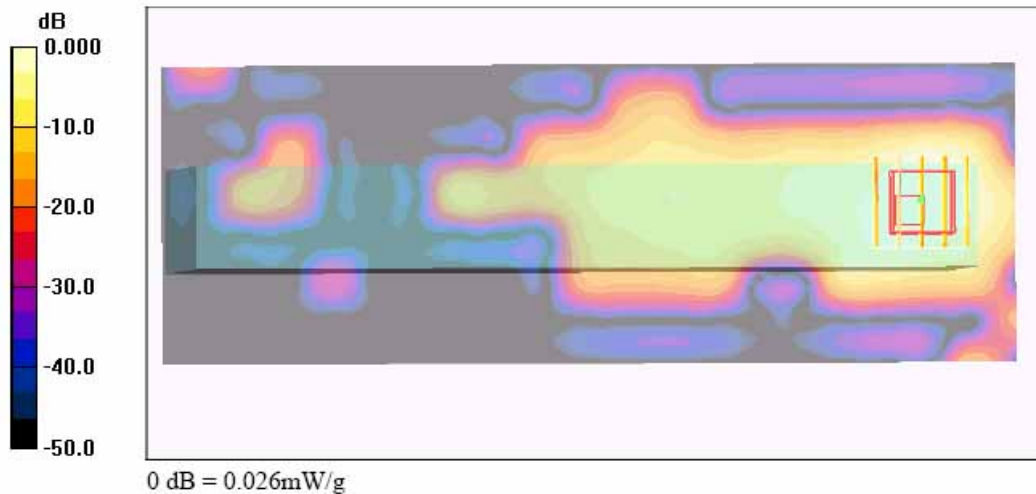

Test Laboratory: Sporton International Inc. SAR/HAC Testing Lab

Date: 2007/12/21

Body_CDMA2000 Ch600_Bottom Side with 0cm Gap_1xRTT_FCH-RC1_Ant Retract

DUT: 7N3014

Communication System: CDMA ; Frequency: 1880 MHz;Duty Cycle: 1:1

Medium: MSL_1900 Medium parameters used: $f = 1880$ MHz; $\sigma = 1.54$ mho/m; $\epsilon_r = 51.8$; $\rho = 1000$ kg/m³

Ambient Temperature : 22.9 °C; Liquid Temperature : 21.6 °C

DASY4 Configuration:

- Probe: ET3DV6 - SN1787; ConvF(4.68, 4.68, 4.68); Calibrated: 2007/8/28
- Sensor-Surface: 4mm (Mechanical Surface Detection)
- Electronics: DAE4 Sn778; Calibrated: 2007/9/17
- Phantom: ELI 4.0; Type: QDOVA001BA; Serial: 1029
- Measurement SW: DASY4, V4.7 Build 55; Postprocessing SW: SEMCAD, V1.8 Build 176

Ch600/Area Scan (71x201x1): Measurement grid: dx=15mm, dy=15mm

Maximum value of SAR (interpolated) = 0.000 mW/g

Ch600/Zoom Scan (5x5x7)/Cube 0: Measurement grid: dx=8mm, dy=8mm, dz=5mm

Reference Value = 0.470 V/m; Power Drift = 0.107 dB

Peak SAR (extrapolated) = 0.001 W/kg

SAR(1 g) = 1.8e-005 mW/g; SAR(10 g) = 1.91e-006 mW/g

Maximum value of SAR (measured) = 0.001 mW/g

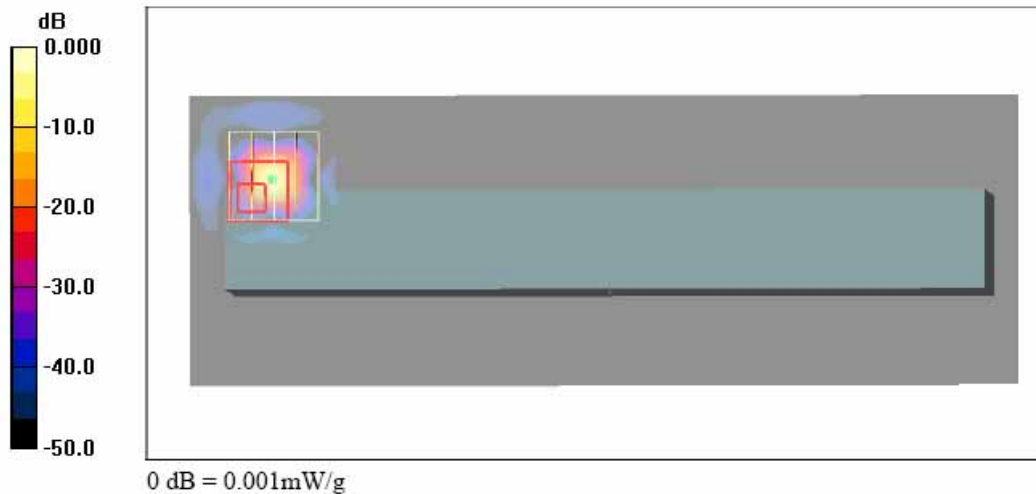

Test Laboratory: Sporton International Inc. SAR/HAC Testing Lab

Date: 2007/12/21

Body_CDMA2000 Ch600_Bottom Side with 0cm Gap_1xRTT_FCH-RC1_Ant Extend

DUT: 7N3014

Communication System: CDMA ; Frequency: 1880 MHz;Duty Cycle: 1:1

Medium: MSL_1900 Medium parameters used: f = 1880 MHz; $\sigma = 1.54$ mho/m; $\epsilon_r = 51.8$; $\rho = 1000$ kg/m³

Ambient Temperature : 22.9 °C; Liquid Temperature : 21.6 °C

DASY4 Configuration:

- Probe: ET3DV6 - SN1787; ConvF(4.68, 4.68, 4.68); Calibrated: 2007/8/28
- Sensor-Surface: 4mm (Mechanical Surface Detection)
- Electronics: DAE4 Sn778; Calibrated: 2007/9/17
- Phantom: ELI 4.0; Type: QDOVA001BA; Serial: 1029
- Measurement SW: DASY4, V4.7 Build 55; Postprocessing SW: SEMCAD, V1.8 Build 176

Ch600/Area Scan (71x201x1): Measurement grid: dx=15mm, dy=15mm

Maximum value of SAR (interpolated) = 0.047 mW/g

Ch600/Zoom Scan (5x5x7)/Cube 0: Measurement grid: dx=8mm, dy=8mm, dz=5mm

Reference Value = 0.558 V/m; Power Drift = 0.199 dB

Peak SAR (extrapolated) = 0.073 W/kg

SAR(1 g) = 0.045 mW/g; SAR(10 g) = 0.028 mW/g

Maximum value of SAR (measured) = 0.049 mW/g

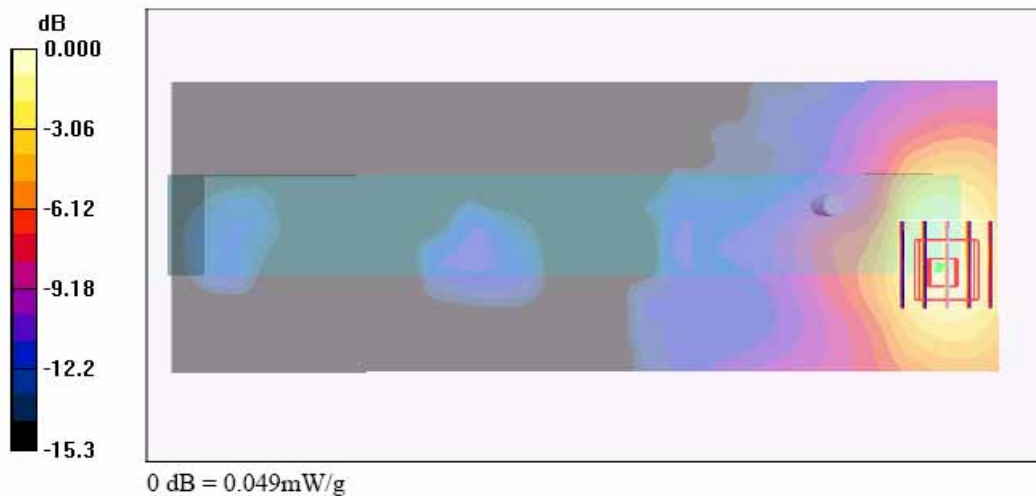

Test Laboratory: Sporton International Inc. SAR/HAC Testing Lab

Date: 2007/12/21

Body_CDMA2000 Ch600_Right Side with 0cm Gap_1xRTT_FCH-RC1_Ant Retract

DUT: 7N3014

Communication System: CDMA ; Frequency: 1880 MHz;Duty Cycle: 1:1

Medium: MSL_1900 Medium parameters used: $f = 1880 \text{ MHz}$; $\sigma = 1.54 \text{ mho/m}$; $\epsilon_r = 51.8$; $\rho = 1000 \text{ kg/m}^3$

Ambient Temperature : 22.9 °C; Liquid Temperature : 21.6 °C

DASY4 Configuration:

- Probe: ET3DV6 - SN1787; ConvF(4.68, 4.68, 4.68); Calibrated: 2007/8/28
- Sensor-Surface: 4mm (Mechanical Surface Detection)
- Electronics: DAE4 Sn778; Calibrated: 2007/9/17
- Phantom: ELI 4.0; Type: QDOVA001BA; Serial: 1029
- Measurement SW: DASY4, V4.7 Build 55; Postprocessing SW: SEMCAD, V1.8 Build 176

Ch600/Area Scan (71x181x1): Measurement grid: $dx=15\text{mm}$, $dy=15\text{mm}$

Maximum value of SAR (interpolated) = 0.001 mW/g

Ch600/Zoom Scan (5x5x7)/Cube 0: Measurement grid: $dx=8\text{mm}$, $dy=8\text{mm}$, $dz=5\text{mm}$

Reference Value = 0.157 V/m; Power Drift = 0.164 dB

Peak SAR (extrapolated) = 0.005 W/kg

SAR(1 g) = 0.000989 mW/g; SAR(10 g) = 0.000434 mW/g

Maximum value of SAR (measured) = 0.002 mW/g

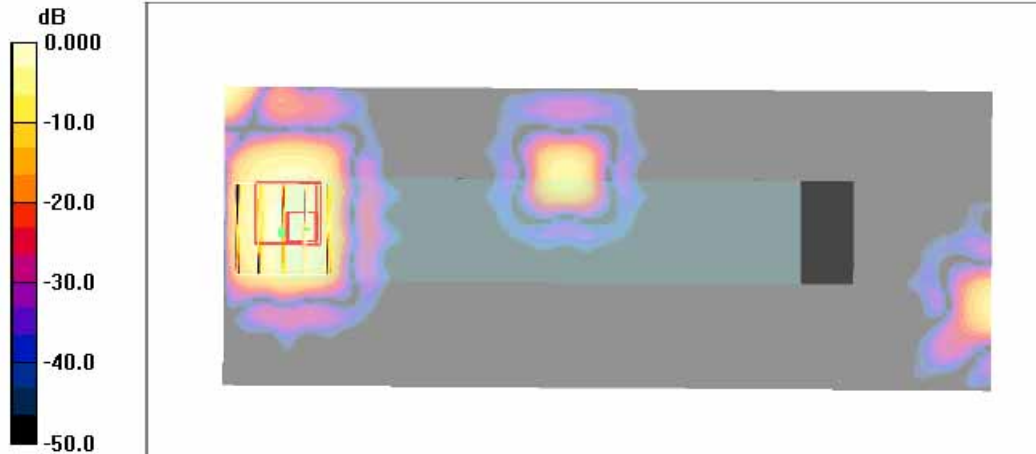

0 dB = 0.002mW/g

Test Laboratory: Sporton International Inc. SAR/HAC Testing Lab

Date : 2007/12/21

Body_CDMA2000 Ch600_Left Side with 0cm Gap_1xRTT_FCH-RC1_Ant Extend

DUT: 7N3014

Communication System: CDMA ; Frequency: 1880 MHz;Duty Cycle: 1:1

Medium: MSL_1900 Medium parameters used: f = 1880 MHz; $\sigma = 1.54$ mho/m; $\epsilon_r = 51.8$; $\rho = 1000$ kg/m³

Ambient Temperature : 22.9 °C; Liquid Temperature : 21.6 °C

DASY4 Configuration:

- Probe: ET3DV6 - SNI1787; ConvF(4.68, 4.68, 4.68); Calibrated: 2007/8/28
- Sensor-Surface: 4mm (Mechanical Surface Detection)
- Electronics: DAE4 Sn778; Calibrated: 2007/9/17
- Phantom: ELI 4.0; Type: QDOVA001BA; Serial: 1029
- Measurement SW: DASY4, V4.7 Build 55; Postprocessing SW: SEMCAD, V1.8 Build 176

Ch600/Area Scan (71x181x1): Measurement grid: dx=15mm, dy=15mm

Maximum value of SAR (interpolated) = 0.182 mW/g

Ch600/Zoom Scan (5x5x7)/Cube 0: Measurement grid: dx=8mm, dy=8mm, dz=5mm

Reference Value = 4.76 V/m; Power Drift = -0.182 dB

Peak SAR (extrapolated) = 0.241 W/kg

SAR(1 g) = 0.164 mW/g; SAR(10 g) = 0.105 mW/g

Maximum value of SAR (measured) = 0.172 mW/g

Ch600/Zoom Scan (5x5x7)/Cube 1: Measurement grid: dx=8mm, dy=8mm, dz=5mm

Reference Value = 4.76 V/m; Power Drift = -0.182 dB

Peak SAR (extrapolated) = 0.222 W/kg

SAR(1 g) = 0.146 mW/g; SAR(10 g) = 0.095 mW/g

Maximum value of SAR (measured) = 0.157 mW/g

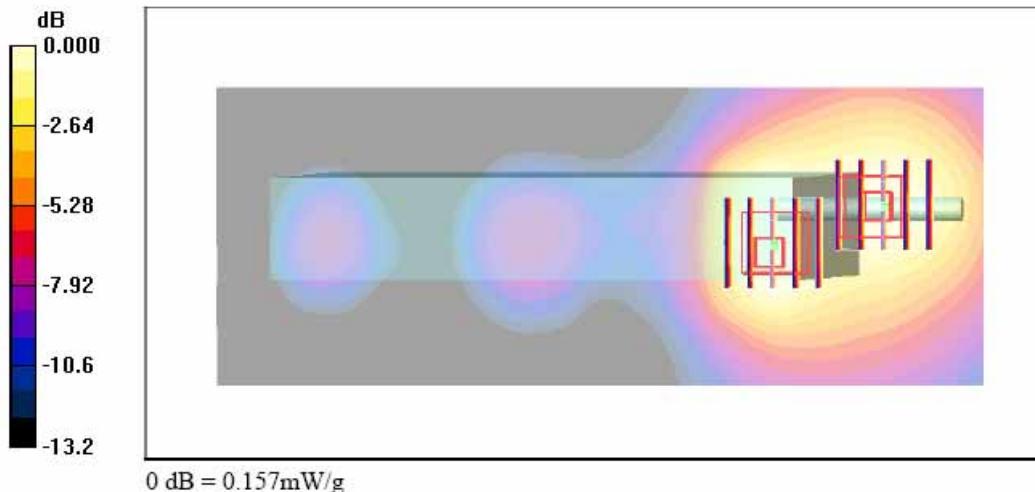

Test Laboratory: Sporton International Inc. SAR/HAC Testing Lab

Date : 2007/12/21

Body_CDMA2000 Ch600_Left Side with 0cm Gap_1xRTT_FCH-RC1_Ant Retract

DUT: 7N3014

Communication System: CDMA ; Frequency: 1880 MHz;Duty Cycle: 1:1

Medium: MSL_1900 Medium parameters used: f = 1880 MHz; $\sigma = 1.54$ mho/m; $\epsilon_r = 51.8$; $\rho = 1000$ kg/m³

Ambient Temperature : 22.9 °C; Liquid Temperature : 21.6 °C

DASY4 Configuration:

- Probe: ET3DV6 - SN1787; ConvF(4.68, 4.68, 4.68); Calibrated: 2007/8/28
- Sensor-Surface: 4mm (Mechanical Surface Detection)
- Electronics: DAE4 Sn778; Calibrated: 2007/9/17
- Phantom: ELI 4.0; Type: QDOVA001BA; Serial: 1029
- Measurement SW: DASY4, V4.7 Build 55; Postprocessing SW: SEMCAD, V1.8 Build 176

Ch600/Area Scan (71x181x1): Measurement grid: dx=15mm, dy=15mm

Maximum value of SAR (interpolated) = 0.008 mW/g

Ch600/Zoom Scan (5x5x7)/Cube 0: Measurement grid: dx=8mm, dy=8mm, dz=5mm

Reference Value = 1.09 V/m; Power Drift = -0.158 dB

Peak SAR (extrapolated) = 0.009 W/kg

SAR(1 g) = 0.00486 mW/g; SAR(10 g) = 0.00231 mW/g

Maximum value of SAR (measured) = 0.005 mW/g

Ch600/Zoom Scan (5x5x7)/Cube 1: Measurement grid: dx=8mm, dy=8mm, dz=5mm

Reference Value = 1.09 V/m; Power Drift = -0.158 dB

Peak SAR (extrapolated) = 0.009 W/kg

SAR(1 g) = 0.00457 mW/g; SAR(10 g) = 0.00181 mW/g

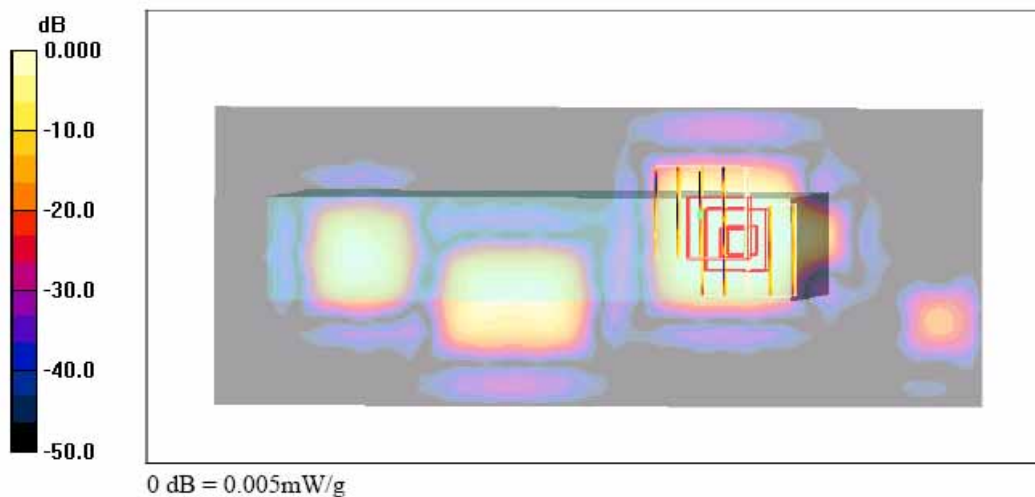

Test Laboratory: Sporton International Inc. SAR/HAC Testing Lab

Date : 2007/12/21

Body_CDMA2000 Ch600_Right Side with 0cm Gap_1xRTT_FCH-RC1_Ant Extend

DUT: 7N3014

Communication System: CDMA ; Frequency: 1880 MHz;Duty Cycle: 1:1

Medium: MSL_1900 Medium parameters used: $f = 1880$ MHz; $\sigma = 1.54$ mho/m; $\epsilon_r = 51.8$; $\rho = 1000$ kg/m³

Ambient Temperature : 22.9 °C; Liquid Temperature : 21.6 °C

DASY4 Configuration:

- Probe: ET3DV6 - SN1787; ConvF(4.68, 4.68, 4.68); Calibrated: 2007/8/28
- Sensor-Surface: 4mm (Mechanical Surface Detection)
- Electronics: DAE4 Sn778; Calibrated: 2007/9/17
- Phantom: ELI 4.0; Type: QDOVA001BA; Serial: 1029
- Measurement SW: DASY4, V4.7 Build 55; Postprocessing SW: SEMCAD, V1.8 Build 176

Ch600/Area Scan (71x181x1): Measurement grid: dx=15mm, dy=15mm

Maximum value of SAR (interpolated) = 0.033 mW/g

Ch600/Zoom Scan (5x5x7)/Cube 0: Measurement grid: dx=8mm, dy=8mm, dz=5mm

Reference Value = 1.43 V/m; Power Drift = 0.150 dB

Peak SAR (extrapolated) = 0.047 W/kg

SAR(1 g) = 0.031 mW/g; SAR(10 g) = 0.020 mW/g

Maximum value of SAR (measured) = 0.034 mW/g

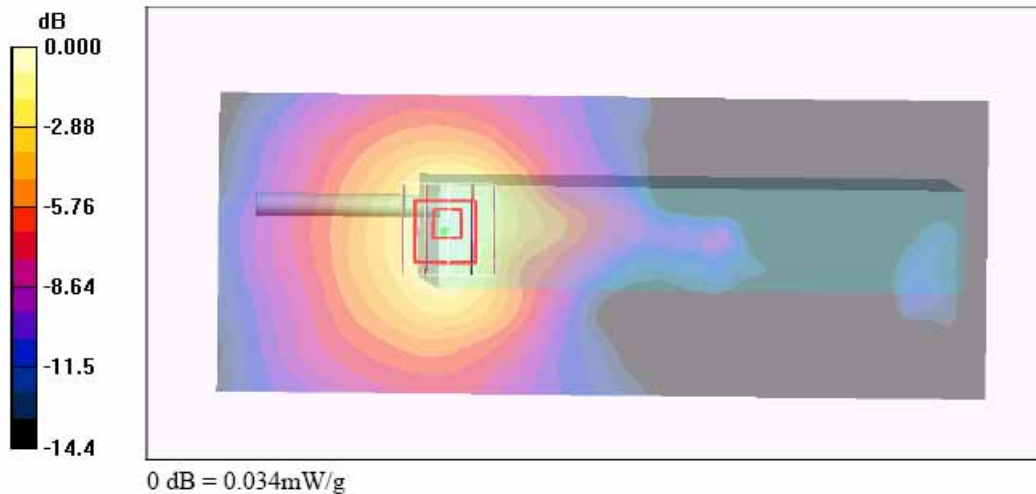



Test Laboratory: Sporton International Inc. SAR/HAC Testing Lab

Date: 2007/12/20

Body_CDMA2000 Ch1013_Rear Face with 0cm Gap_1xRTT_FCH-RC1_Ant Extend_2D

DUT: 7N3014

Communication System: CDMA ; Frequency: 824.7 MHz;Duty Cycle: 1:1

Medium: MSL_850 Medium parameters used: $f = 825$ MHz; $\sigma = 0.959$ mho/m; $\epsilon_r = 55.3$; $\rho = 1000$ kg/m³

Ambient Temperature : 21.8 °C; Liquid Temperature : 21.2 °C

DASY4 Configuration:

- Probe: ET3DV6 - SN1787; ConvF(6.1, 6.1, 6.1); Calibrated: 2007/8/28
- Sensor-Surface: 4mm (Mechanical Surface Detection)
- Electronics: DAE4 Sn778; Calibrated: 2007/9/17
- Phantom: ELI 4.0; Type: QDOVA001BA; Serial: 1029
- Measurement SW: DASY4, V4.7 Build 55; Postprocessing SW: SEMCAD, V1.8 Build 176

Ch1013/Area Scan (61x51x1): Measurement grid: dx=15mm, dy=15mm

Maximum value of SAR (interpolated) = 1.61 mW/g

Ch1013/Zoom Scan (5x5x7)/Cube 0: Measurement grid: dx=8mm, dy=8mm, dz=5mm

Reference Value = 5.90 V/m; Power Drift = 0.111 dB

Peak SAR (extrapolated) = 2.19 W/kg

SAR(1 g) = 1.49 mW/g; SAR(10 g) = 0.974 mW/g

Maximum value of SAR (measured) = 1.60 mW/g

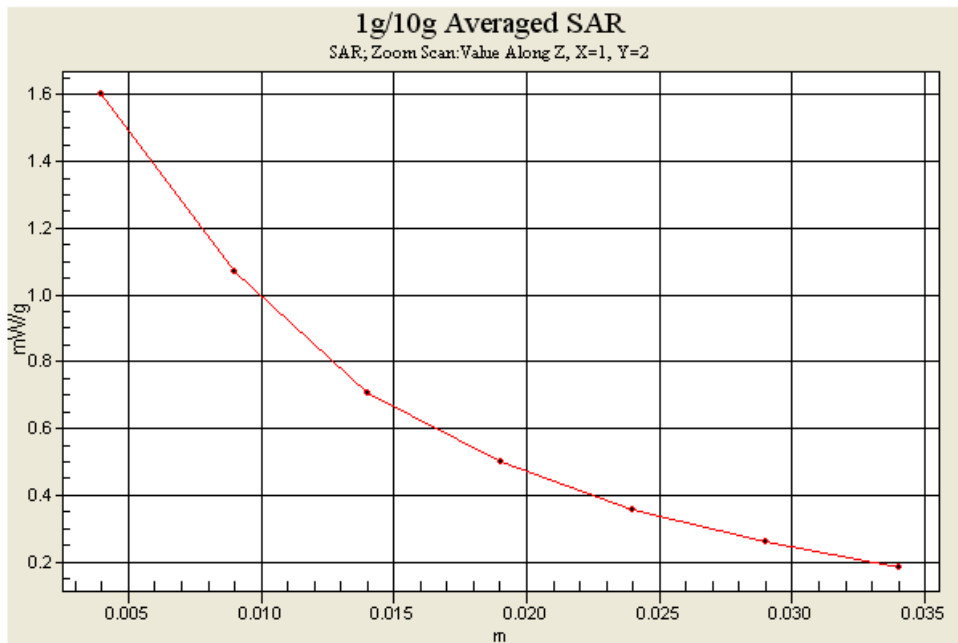



Test Laboratory: Sporton International Inc. SAR/HAC Testing Lab

Date: 2007/12/21

Body_CDMA2000 Ch600_Rear Face with 0cm Gap_1xRTT_FCH-RC1_Ant Extend_ for E100_2D

DUT: 7N3014

Communication System: CDMA ; Frequency: 1880 MHz;Duty Cycle: 1:1

Medium: MSL_1900 Medium parameters used: $f = 1880$ MHz; $\sigma = 1.54$ mho/m; $\epsilon_r = 51.8$; $\rho = 1000$ kg/m³

Ambient Temperature : 22.8 °C; Liquid Temperature : 21.2 °C

DASY4 Configuration:

- Probe: ET3DV6 - SN1787; ConvF(4.68, 4.68, 4.68); Calibrated: 2007/8/28
- Sensor-Surface: 4mm (Mechanical Surface Detection)
- Electronics: DAE4 Sn778; Calibrated: 2007/9/17
- Phantom: ELI 4.0; Type: QDOVA001BA; Serial: 1029
- Measurement SW: DASY4, V4.7 Build 55; Postprocessing SW: SEMCAD, V1.8 Build 176

Ch600/Area Scan (61x51x1): Measurement grid: dx=15mm, dy=15mm

Maximum value of SAR (interpolated) = 1.61 mW/g

Ch600/Zoom Scan (5x5x7)/Cube 0: Measurement grid: dx=8mm, dy=8mm, dz=5mm

Reference Value = 0.892 V/m; Power Drift = 0.142 dB

Peak SAR (extrapolated) = 1.92 W/kg

SAR(1 g) = 1.22 mW/g; SAR(10 g) = 0.682 mW/g

Maximum value of SAR (measured) = 1.36 mW/g

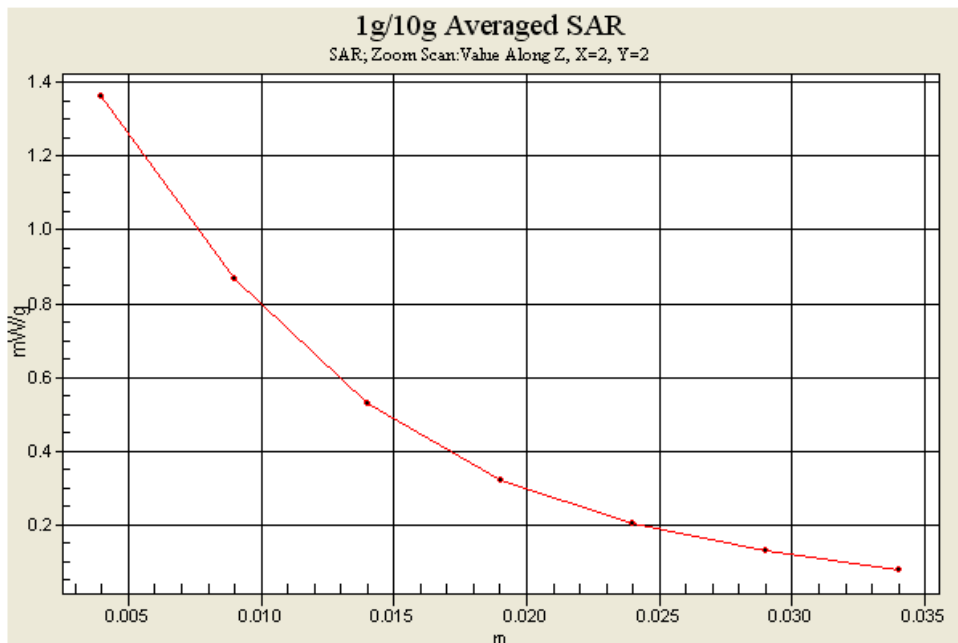



Appendix C – Calibration Data

Calibration Laboratory of Schmid & Partner Engineering AG



S Schweizerischer Kalibrierdienst
C Service suisse d'etalonnage
S Servizio svizzero di taratura
S Swiss Calibration Service

Accredited by the Swiss Federal Office of Metrology and Accreditation
The Swiss Accreditation Service is one of the signatories to the EA Multilateral Agreement for the recognition of calibration certificates

Accreditation No.: SCS 108

Client Sporton (Auden)

Certificate No: D835V2-499_Mar06

CALIBRATION CERTIFICATE

Object: D835V2 - SN: 499
Calibration procedure(s): QA CAL-05.v6
Calibration date: March 15, 2006
Condition of the calibrated item: In Tolerance

This calibration certificate documents the traceability to national standards, which realize the physical units of measurements (SI).

All calibrations have been conducted in the closed laboratory facility: environment temperature (22 ± 3)°C and humidity < 70%.

Calibration Equipment used (M&TE critical for calibration)

Table with 4 columns: Primary Standards, ID #, Cal Date (Calibrated by, Certificate No.), Scheduled Calibration. Lists equipment like Power meter EPM-442A, Reference 20 dB Attenuator, etc.

Table with 4 columns: Secondary Standards, ID #, Check Date (in house), Scheduled Check. Lists equipment like Power sensor HP 8481A, RF generator Agilent E4421B, etc.

Calibrated by: Judith Müller, Laboratory Technician
Approved by: Katja Pokovic, Technical Manager

Issued: March 16, 2006

This calibration certificate shall not be reproduced except in full without written approval of the laboratory.