



FCC RF Test Report

APPLICANT : Getac Technology Corporation
EQUIPMENT : Notebook PC
BRAND NAME : Getac
MODEL NAME : B300
FCC ID : MAU304
STANDARD : FCC Part 15 Subpart E
CLASSIFICATION : Unlicensed National Information Infrastructure (UNII)

The product was received on Oct. 18, 2007 and completely tested on Nov. 17, 2007. We, SPORTON INTERNATIONAL INC., would like to declare that the tested sample has been evaluated in accordance with the procedures given in ANSI C63.4-2003 and shown compliance with the applicable technical standards.

The test results in this report apply exclusively to the tested model / sample. Without written approval of SPORTON INTERNATIONAL INC., the test report shall not be reproduced except in full.

Reviewed by: Roy Wu / Manager



SPORTON INTERNATIONAL INC.

No. 52, Hwa Ya 1st Rd., Hwa Ya Technology Park, Kwei-Shan Hsiang, Tao Yuan Hsien, Taiwan, R.O.C.



TABLE OF CONTENTS

- 1. General Description of Equipment under Test..... 4**
 - 1.1 Applicant..... 4
 - 1.2 Manufacturer 4
 - 1.3 Basic Description of Equipment under Test..... 4
- 2. Test Configuration of Equipment under Test 6**
 - 2.1 Test Manner 6
 - 2.2 Description of Test System..... 7
 - 2.3 Connection Diagram of Test System 7
- 3. Operation of Equipment under Test 9**
- 4. General Information of Test10**
 - 4.1 Test Voltage10
 - 4.2 Standard for Methods of Measurement10
 - 4.3 Test in Compliance.....10
 - 4.4 Frequency Range10
 - 4.5 Test Distance.....10
- 5. Report of Measurements and Examinations.....11**
 - 5.1 List of Measurements and Examinations11
 - 5.2 Emission Bandwidth12
 - 5.3 Peak Transmit Power30
 - 5.4 Peak Power Spectral Density49
 - 5.5 Test of Conducted Emission.....68
 - 5.6 Test of Radiated Emission.....71
 - 5.7 Band Edges Measurement138
 - 5.8 Peak Excursion Ratio Measurement145
 - 5.9 Frequency Stability164
 - 5.10 Automatically discontinue transmission166
 - 5.11 Antenna Requirements167
- 5 List of Measuring Equipments168**
- 6 Uncertainty of Test Site169**
- Appendix A. Photographs of EUT**
- Appendix B. Setup Photographs**



REVISION HISTORY

REPORT NO.	VERSION	DESCRIPTION	ISSUED DATE
FR980406C	Rev. 01	Initial issue of report	Sep. 04, 2009



1. General Description of Equipment under Test

1.1 Applicant

Getac Technology Corporation

5F., Building A, No. 209, Sec. 1, Nangang Rd., Nangang Dist., Taipei City 11568, Taiwan, R.O.C.

1.2 Manufacturer

GeTAC Technology(Kunshan) LTD.

No. 269, 2nd Road, Export Processing Zone, Changjiang South Road, Kunshan, Jiangsu, P.R.C.

1.3 Basic Description of Equipment under Test

Product Feature & Specification	
Equipment	Notebook PC
Brand Name	Getac
Model Name	B300
FCC ID	MAU304
Tx/Rx Frequency Range	5150 MHz ~ 5250 MHz 5250 MHz ~ 5350 MHz
Maximum Output Power to Antenna	<5150 MHz ~ 5250 MHz> 802.11a : 16.98 dBm 802.11n (BW 20MHz) : 16.77 dBm 802.11n (BW 40MHz) : 16.84 dBm <5250 MHz ~ 5350 MHz> 802.11a : 17.86 dBm 802.11n (BW 20MHz) : 19.55 dBm 802.11n (BW 40MHz) : 16.81 dBm
Antenna Type	PIFA Antenna with gain 1.55 dBi
HW Version	R03
SW Version	R1.16
Type of Modulation	OFDM (BPSK / QPSK / 16QAM / 64QAM)
EUT Stage	Identical Prototype

Remark:

1. For other wireless features of this EUT, test report will be issued separately.
2. This test report recorded only product characteristics and test results of Unlicensed National Information Infrastructure (UNII).

List of Accessory:

Specification of Accessory		
AC Adapter 1	Brand Name	DELTA
	Model Name	ADP-90SB BB
	Power Rating	I/P:100-240Vac, 50-60Hz, 1.5A; O/P: 19Vdc, 4.74A
	DC Power Cord Type	1.75 meter shielded cable with ferrite core
AC Adapter 2	Brand Name	Getac
	Model Name	ADM-9019M
	Power Rating	I/P:100-240Vac, 50-60Hz, 1.5A; O/P: 19Vdc, 4.74A
	DC Power Cord Type	1.55 meter shielded cable with ferrite core
Battery	Brand Name	SAYNO
	Model Name	BP3S3P2550(P)
	Power Rating	10.8Vdc, 7650Ah
	Type	Li-ion
LCD Panel	Brand Name	Sanyo
	Model Name	L5S30348P01
WWAN Module	Brand Name	QUALCOMM
	Model Name	Gobi2000
WLAN Module	Brand Name	Intel
	Model Name	wireless 4965
Bluetooth Module	Brand Name	Billionton
	Model Name	GUBTCR42M
GPS Module	Brand Name	ENGINE BOARD
	Model Name	GOLOBALSAT.GPI

Remark:

1. The above EUT's information was declared by manufacturer. Please refer to the specifications or user's manual for more detailed description.
2. For accessories equipped with this EUT, please refer to the appendix of the external photo.

2. Test Configuration of Equipment under Test

2.1 Test Manner

- a. The EUT has been associated with peripherals pursuant to ANSI C63.4-2003 and configuration operated in a manner tended to maximize its emission characteristics in a typical application.
- b. Pre-scanned Power Table as below:

Normal mode :

Channel	Frequency (MHz)	Data Rate								
		6M bps	9M bps	12M bps	18M bps	24M bps	36M bps	48M bps	54M bps	
Normal mode	CH 036	5180 MHz	21.08	20.07	20.15	20.84	21.16	20.96	19.95	18.10
	CH 044	5220 MHz	22.55	22.43	22.33	22.49	22.65	22.64	21.58	20.74
	CH 048	5240 MHz	19.88	20.35	20.24	20.47	21.46	20.62	20.08	18.15
	CH 052	5260 MHz	20.04	21.67	21.67	20.44	22.08	21.85	20.54	18.28
	CH 060	5300 MHz	22.02	22.37	21.83	21.69	21.74	21.50	21.14	19.90
	CH 064	5320 MHz	21.41	21.78	21.77	21.69	22.00	21.42	19.78	18.51

11n(a) 20M mode :

Channel	Frequency (MHz)	Data Rate								
		6M bps	9M bps	12M bps	18M bps	24M bps	36M bps	48M bps	54M bps	
11n(a) 20M	CH 036	5180 MHz	23.11	24.25	24.08	23.70	24.23	25.33	25.87	23.66
	CH 044	5220 MHz	24.56	25.50	24.71	24.87	24.54	24.97	25.81	24.54
	CH 048	5240 MHz	22.18	21.88	23.32	22.30	23.48	22.71	22.81	23.14
	CH 052	5260 MHz	23.68	23.17	22.30	22.25	23.92	23.10	23.66	23.33
	CH 060	5300 MHz	24.52	25.17	24.41	24.32	24.95	24.62	24.99	25.05
	CH 064	5320 MHz	23.55	21.96	22.41	22.46	22.12	22.82	22.33	22.53

11n(a) 40M mode :

Channel	Frequency (MHz)	Data Rate								
		6M bps	9M bps	12M bps	18M bps	24M bps	36M bps	48M bps	54M bps	
11n(a) 40M	CH 038	5190 MHz	22.40	22.95	22.83	21.76	22.80	22.62	21.83	22.83
	CH 046	5230 MHz	22.59	23.06	22.42	22.75	22.31	22.70	22.46	22.38
	CH 054	5270 MHz	21.32	22.50	22.29	21.82	22.85	21.78	21.29	22.19
	CH 062	5310 MHz	20.68	20.66	19.68	19.84	19.85	20.40	21.84	21.49

- c. The data rates, 24Mbps, was chosen to being tested in normal mode, and 48Mbps was chosen to being tested in 802.11n(a) BW 20M mode, and 9Mbps was chosen to being tested in 802.11n(a) BW 40M mode, due to the highest RF output power.
- d. The complete test system refers to section 2.2 and EUT for EMI test.
- e. The EUT can operate on 5150MHz to 5250MHz, 5250MHz to 5350MHz as listed in section 1.4.

f. Test Mode for radiated emission and conducted emission:

Application	Test Mode	
Radiated Emission	802.11a	
	Mode 1: CH036_5180 MHz	
	Mode 2: CH044_5220 MHz	
	Mode 3: CH048_5240 MHz	
	Mode 4: CH052_5260 MHz	
	Mode 5: CH060_5300 MHz	
Radiated Emission	Mode 6: CH064_5320 MHz	
	802.11n(a) (BW 20M)	802.11n(a) (BW 40M)
	Mode 7: CH036_5180 MHz	Mode 13: CH038_5190 MHz
	Mode 8: CH044_5220 MHz	Mode 14: CH046_5230 MHz
	Mode 9: CH048_5240 MHz	Mode 15: CH054_5270 MHz
	Mode 10: CH052_5260 MHz	Mode 16: CH062_5310 MHz
Mode 11: CH060_5300 MHz		
Mode 12: CH064_5320 MHz		
Conducted Emission	Mode 1: BT Link + WLAN Link Mode + Adapter 1	

g. Frequency range investigated: conduction 150 KHz to 30 MHz, radiation 30 MHz to 40000MHz.

2.2 Description of Test System

Item	Equipment	Trade Name	Model Name	FCC ID	Data Cable	Power Cord
1.	Bluetooth Earphone	Engotech	ET-BH111	PQY471087	N/A	N/A

2.3 Connection Diagram of Test System

<Radiated Emission>

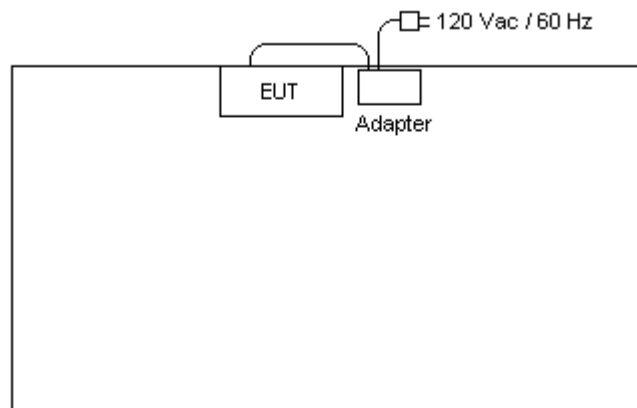

<Conducted Emission>

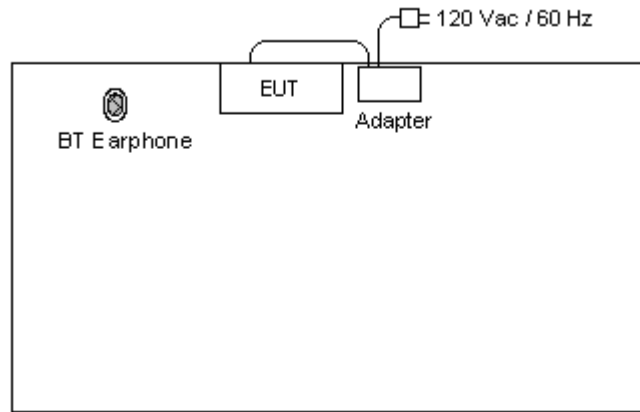



3. Operation of Equipment under Test

The programmed RF Utility is installed in EUT to provide channel selection, power level, data rate and the application type. RF Utility can send transmitting signal for all testing.



4. General Information of Test

Test Site Location : No. 52, Hwa Ya 1st Rd., Hwa Ya Technology Park,
Kwei-Shan Hsiang, Tao Yuan Hsien, Taiwan, R.O.C.
TEL : 886-3-327-3456
FAX : 886-3-328-4978
Test Site No : CO04-HY, 03CH04-HY
FCC Designation No : TW1022

4.1 Test Voltage

AC 120V / 60Hz

4.2 Standard for Methods of Measurement

ANSI C63.4-2003

4.3 Test in Compliance

FCC Part 15, Subpart E

4.4 Frequency Range

- a. Conduction: from 150 kHz to 30 MHz
- b. Radiation: from 9KHz to 40GHz

4.5 Test Distance

The test distance of radiated emission from antenna to EUT is 3 M.



5. Report of Measurements and Examinations

5.1 List of Measurements and Examinations

FCC Rule	Description of Test	Result
15.407(b)(6)	Conducted Emission	Pass
15.407(a)(1)(2)(3)	Peak Transmit Power	Pass
15.407(b)(1)(2)(4)(6)(7)	Radiated Emission	Pass
15.407(a)(1)(2)(3)	Power Spectral Density	Pass
15.407(b)(1)(2)(3)	Band Edges Measurement	Pass
15.203	Antenna Requirement	Pass
15.407(a)(6)	Peak Excursion Ratio Measurement	Pass
15.407(c)	Automatically Discontinue Transmission	Pass



5.2 Emission Bandwidth

5.2.1 Measuring Instruments

As described in chapter 6 of this test report.

5.2.2 Test Procedure

The transmitter output is connected to the spectrum analyzer. For these tests, the resolution bandwidth is 1 MHz, video bandwidth is 3MHz, peak detection and view function is used. The 26 dB bandwidth is defined as the frequency range where the power is higher than the peak power minus 26 dB.

5.2.3 Test Setup Layout

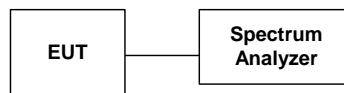

5.2.4 Test Result

- Temperature : 25~26°C
- Relative Humidity : 49~51%
- Test Engineer : CKC

➤ 802.11a Normal mode

Channel	Frequency (MHz)	26dB Emission bandwidth (MHz)	Plot Ref. No.
36	5180	25.38	Mode 1
44	5220	23.40	Mode 2
48	5240	23.76	Mode 3
52	5260	23.76	Mode 4
60	5300	23.28	Mode 5
64	5320	24.00	Mode 6



➤ 802.11n(a) BW 20M mode

Channel	Frequency (MHz)	26dB Emission bandwidth (MHz)	Plot Ref. No.
36	5180	23.70	Mode 7
40	5220	23.94	Mode 8
48	5240	23.58	Mode 9
52	5260	23.64	Mode 10
60	5300	24.00	Mode 11
64	5320	23.88	Mode 12

➤ 802.11n(a) BW 40M mode

Channel	Frequency (MHz)	26dB Emission bandwidth (MHz)	Plot Ref. No.
38	5190	40.92	Mode 13
46	5230	41.64	Mode 14
54	5270	40.92	Mode 15
62	5310	41.04	Mode 16



5.2.5 Test Data

Mode 1

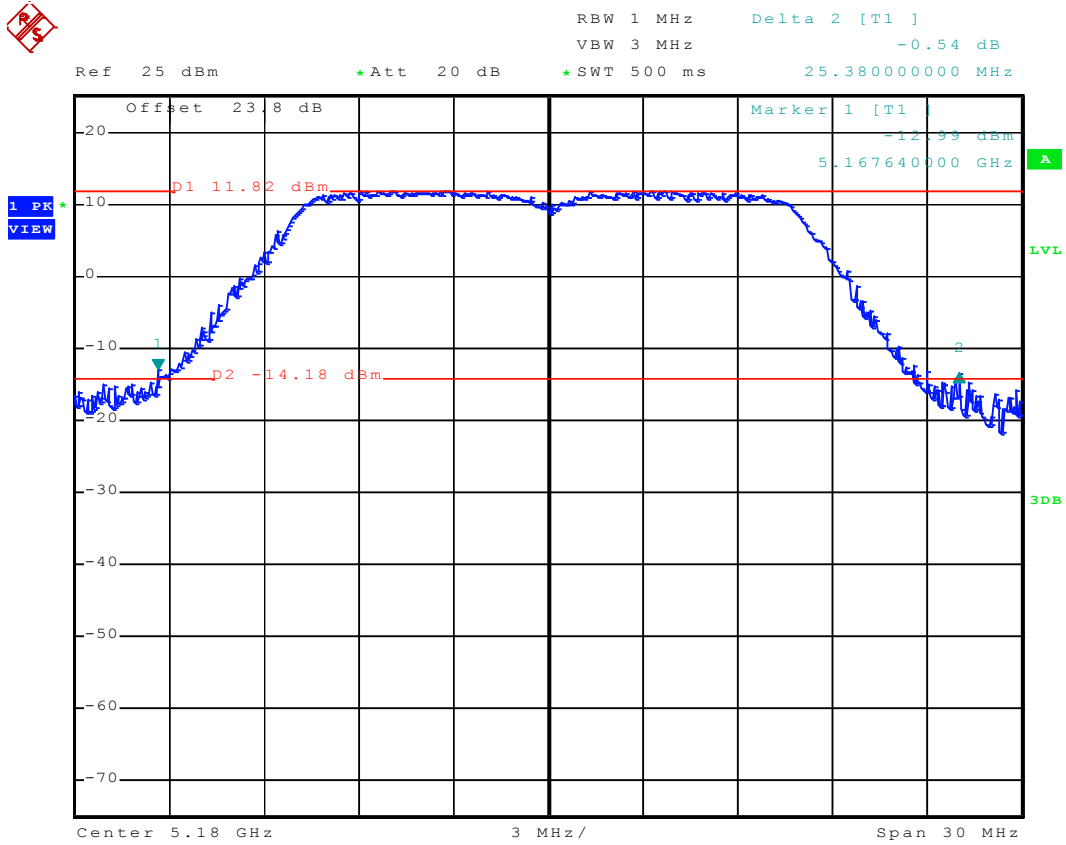

Date: 12.NOV.2007 09:36:19



Mode 2

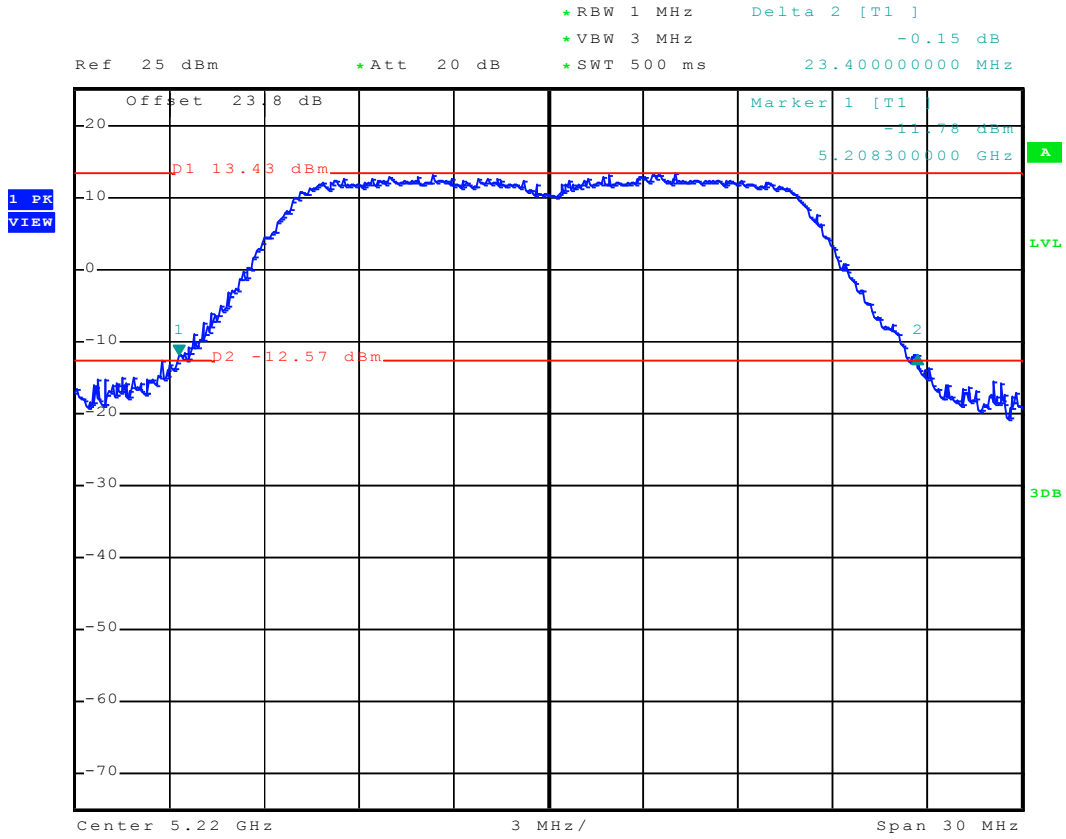

Date: 5 JAN 2008 00:24:08



Mode 3

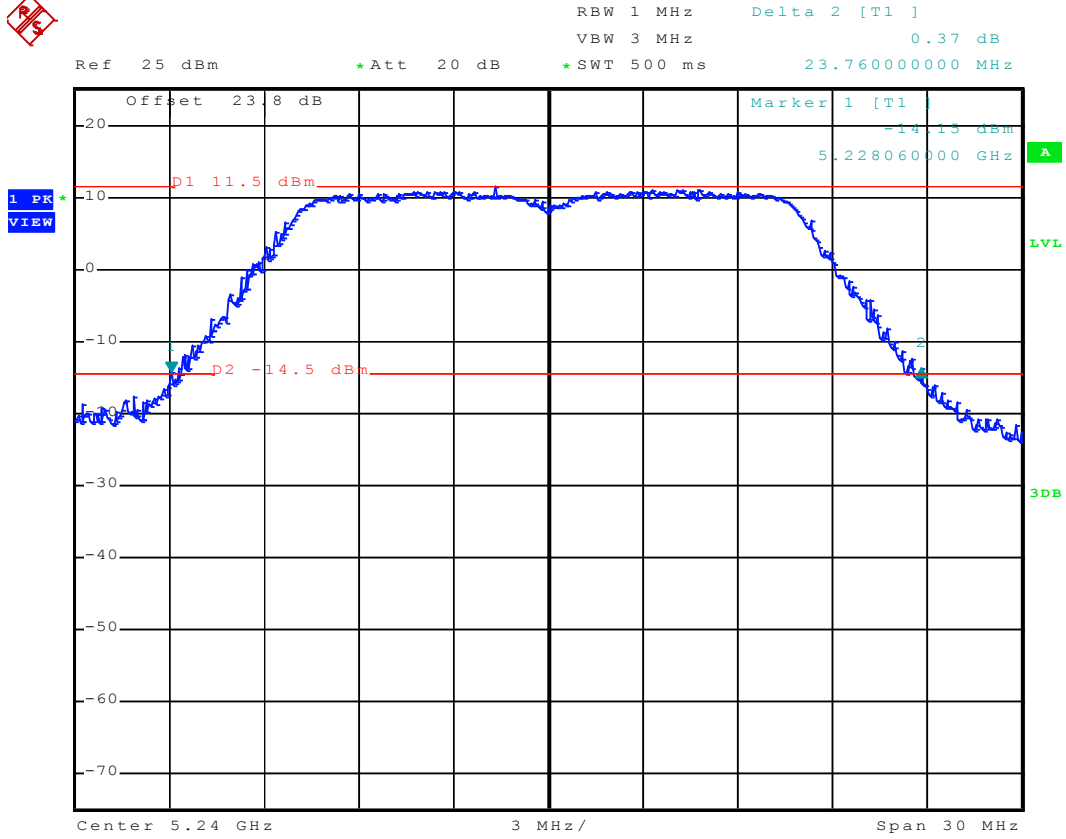

Date: 12.NOV.2007 09:37:14



Mode 4

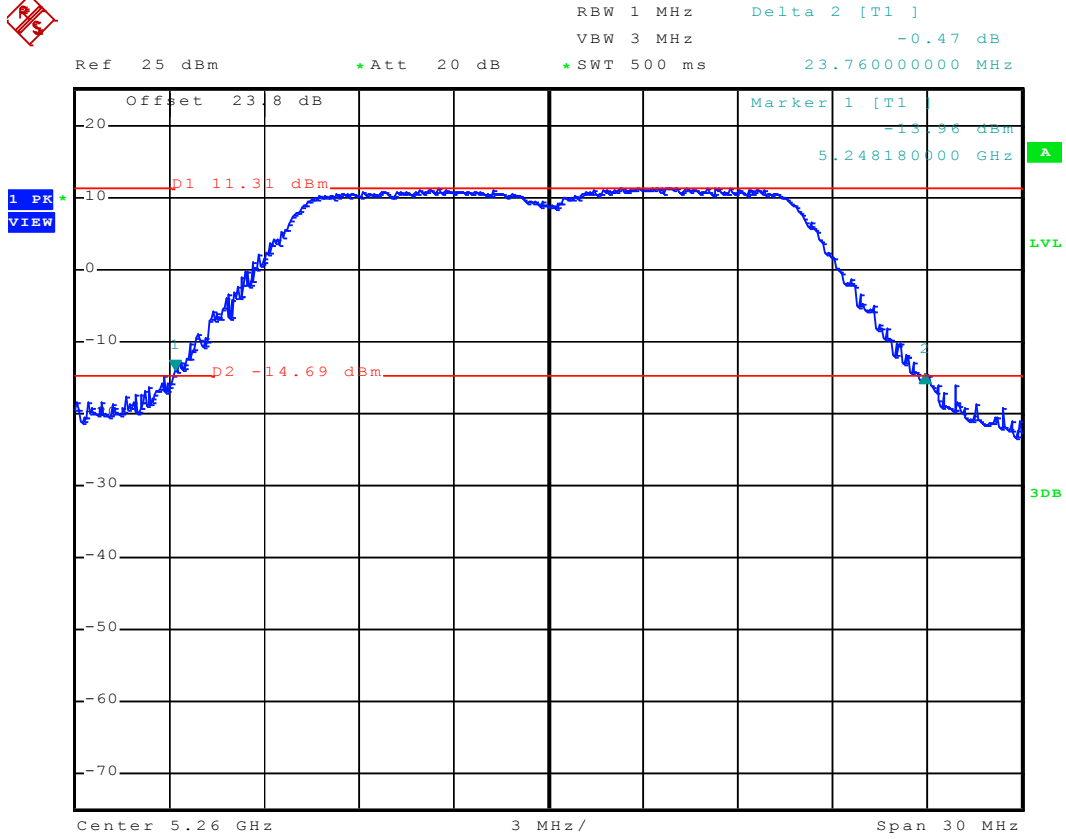

Date: 12.NOV.2007 09:38:34



Mode 5

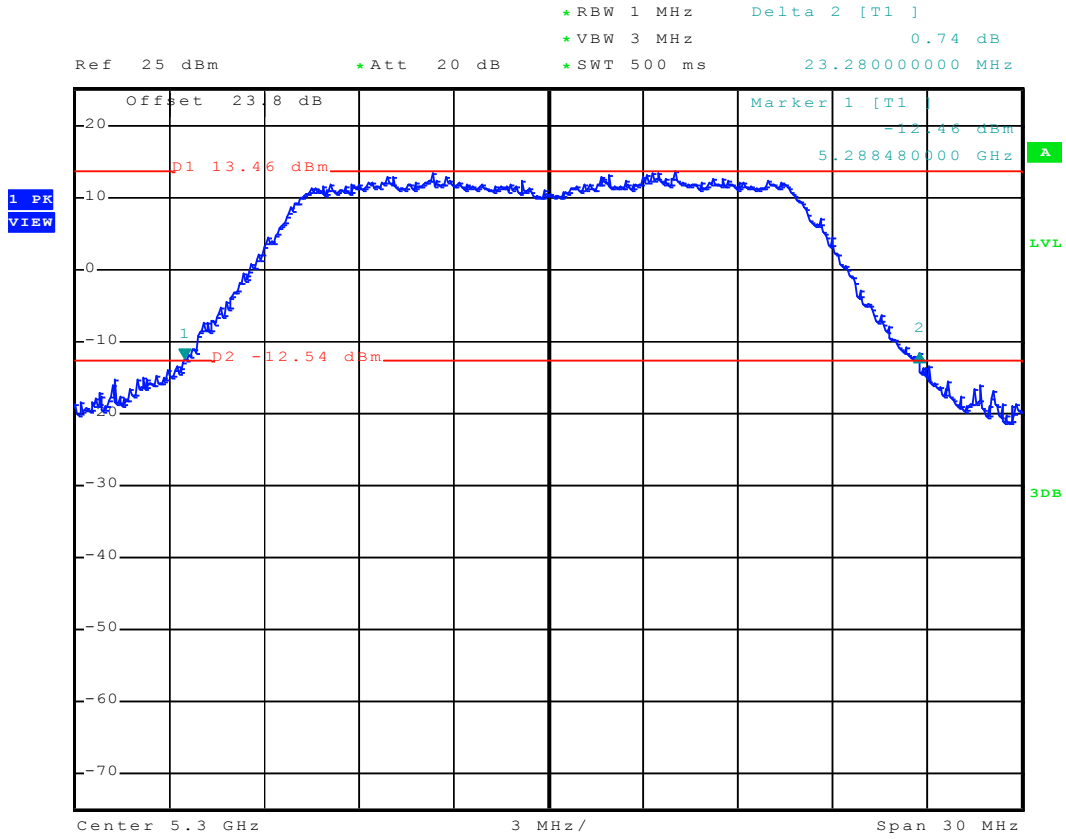

Date: 5 JAN 2008 00:25:00



Mode 6

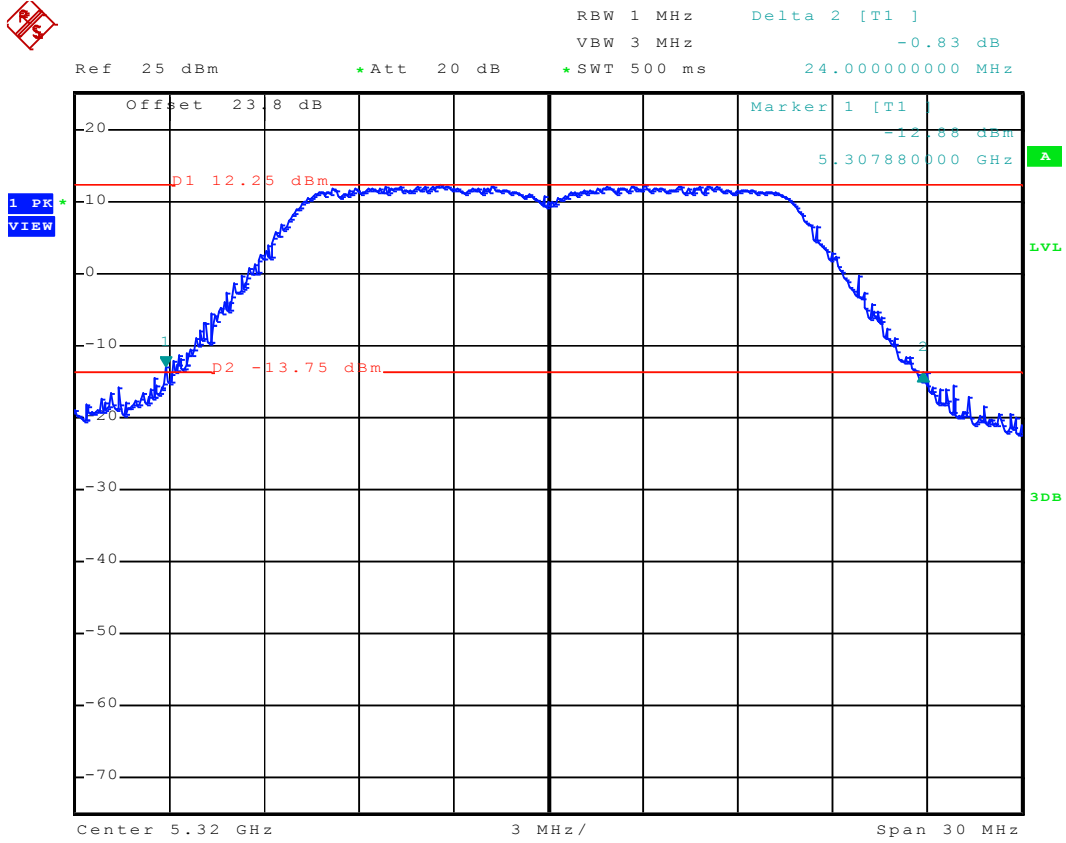

Date: 12.NOV.2007 09:39:47



Mode 7

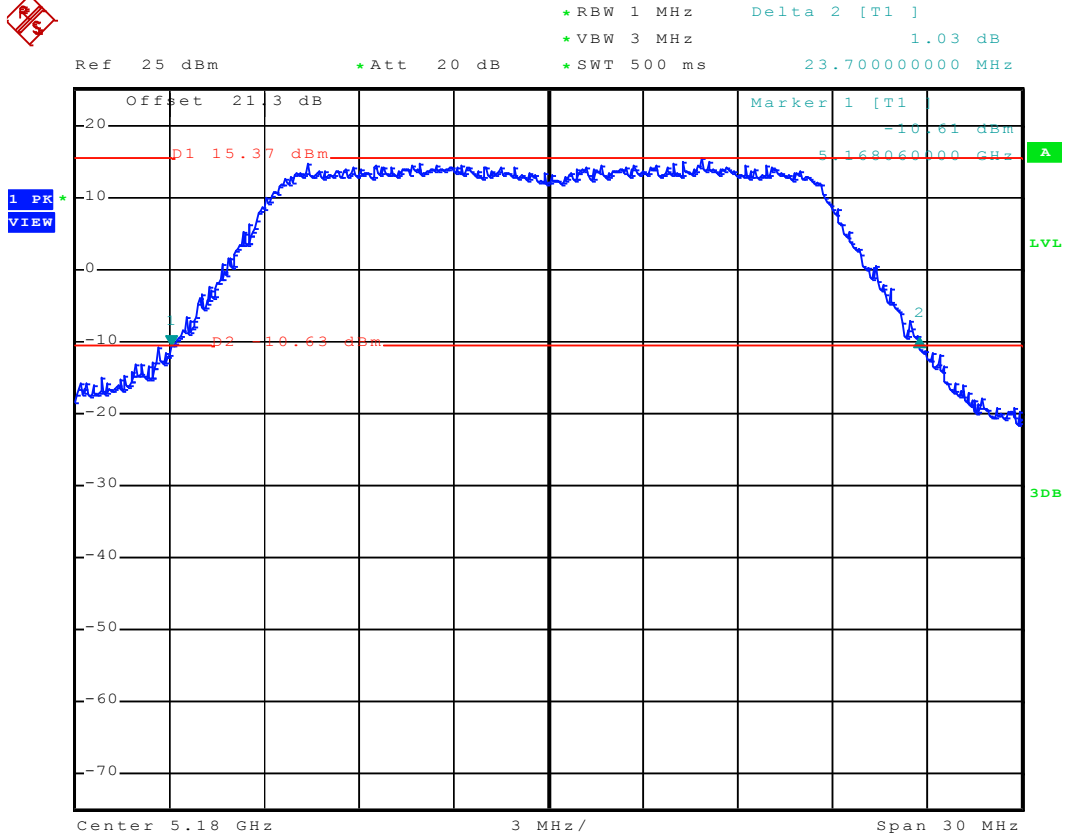

Date: 8.NOV.2007 10:20:55



Mode 8



*RBW 1 MHz Delta 2 [T1]
 *VBW 3 MHz -0.37 dB
 *SWT 500 ms 23.940000000 MHz

Ref 25 dBm

*Att 20 dB

1 PK VIEW

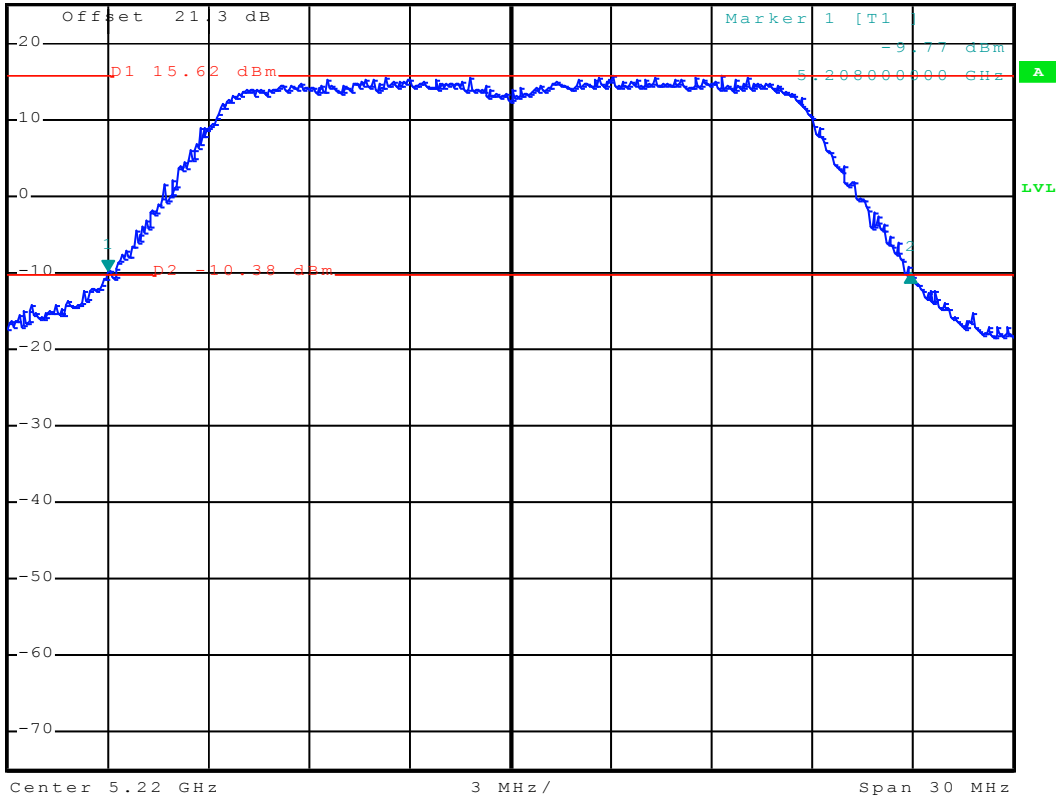

Date: 7.JAN.2008 17:40:17



Mode 9

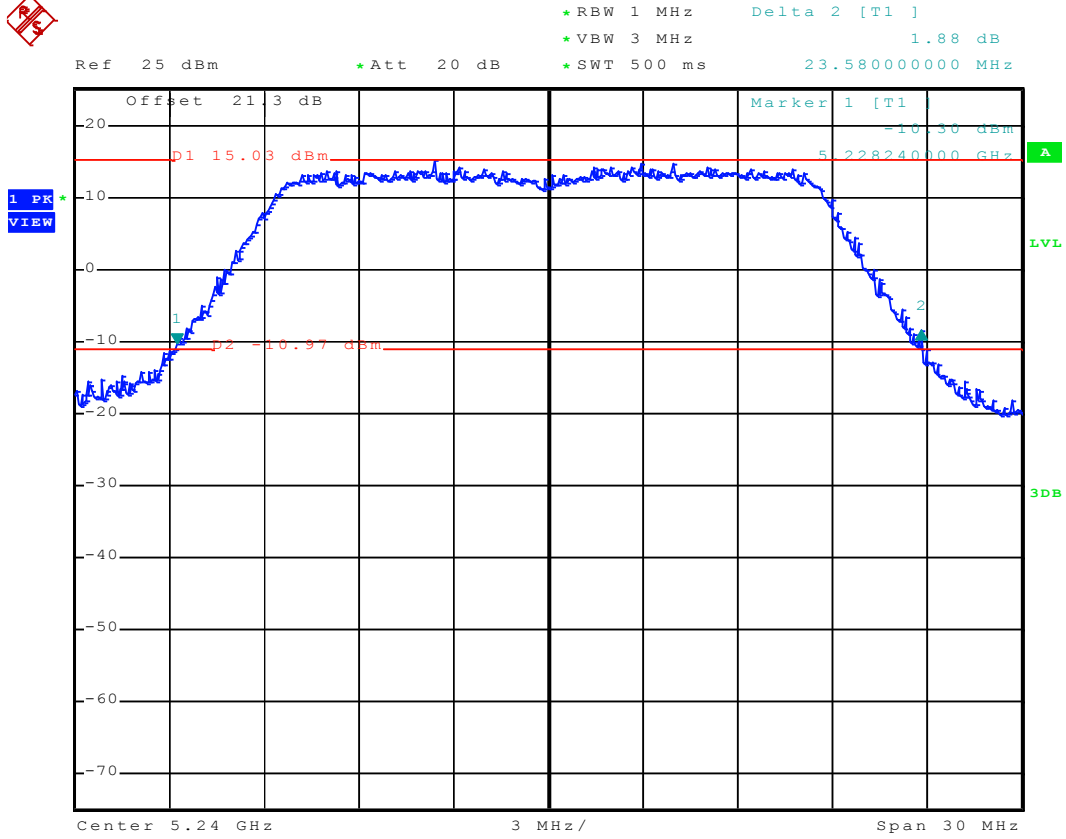

Date: 8.NOV.2007 10:17:08



Mode 10

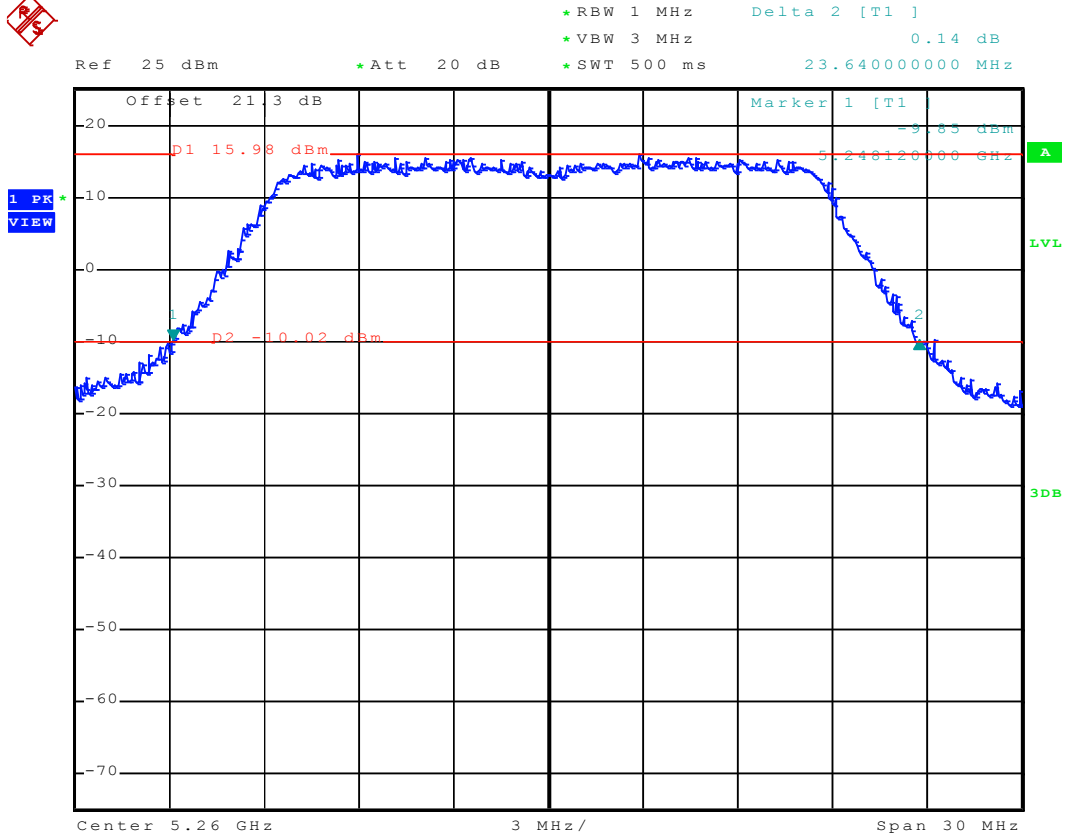

Date: 8.NOV.2007 10:23:13



Mode 11



*RBW 1 MHz Delta 2 [T1]
 *VBW 3 MHz 0.85 dB
 *SWT 500 ms 24.000000000 MHz

Ref 25 dBm

*Att 20 dB

1 PK VIEW

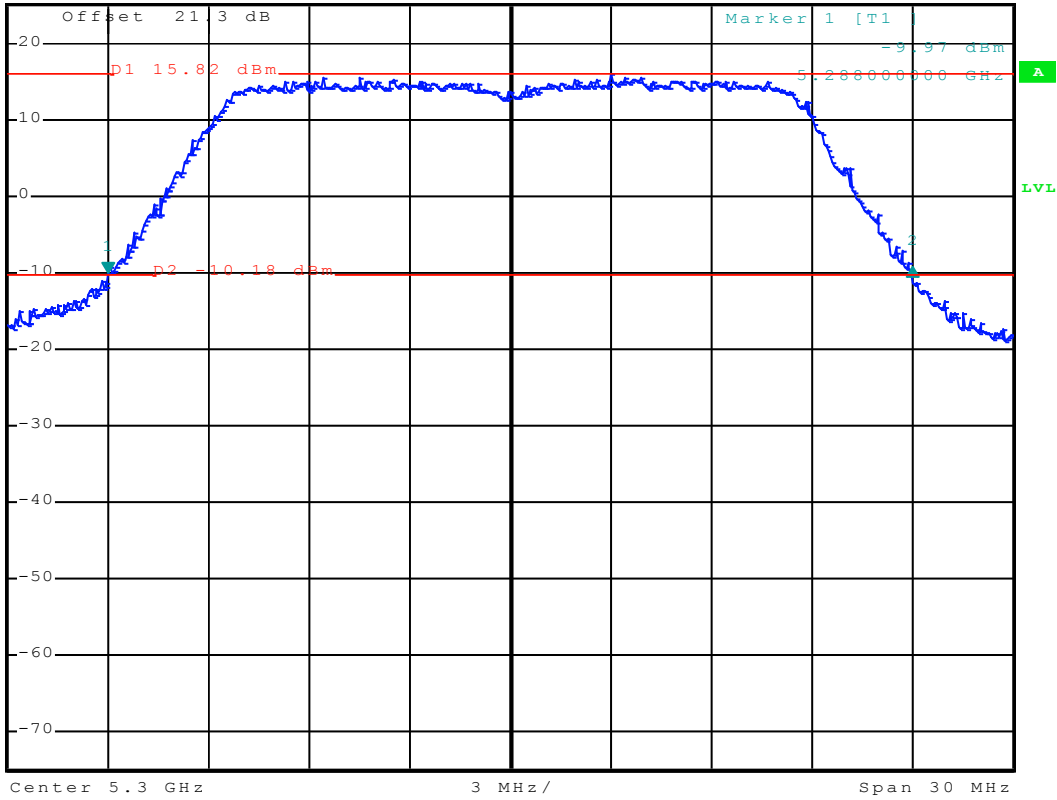

Date: 7.JAN.2008 17:43:04



Mode 12

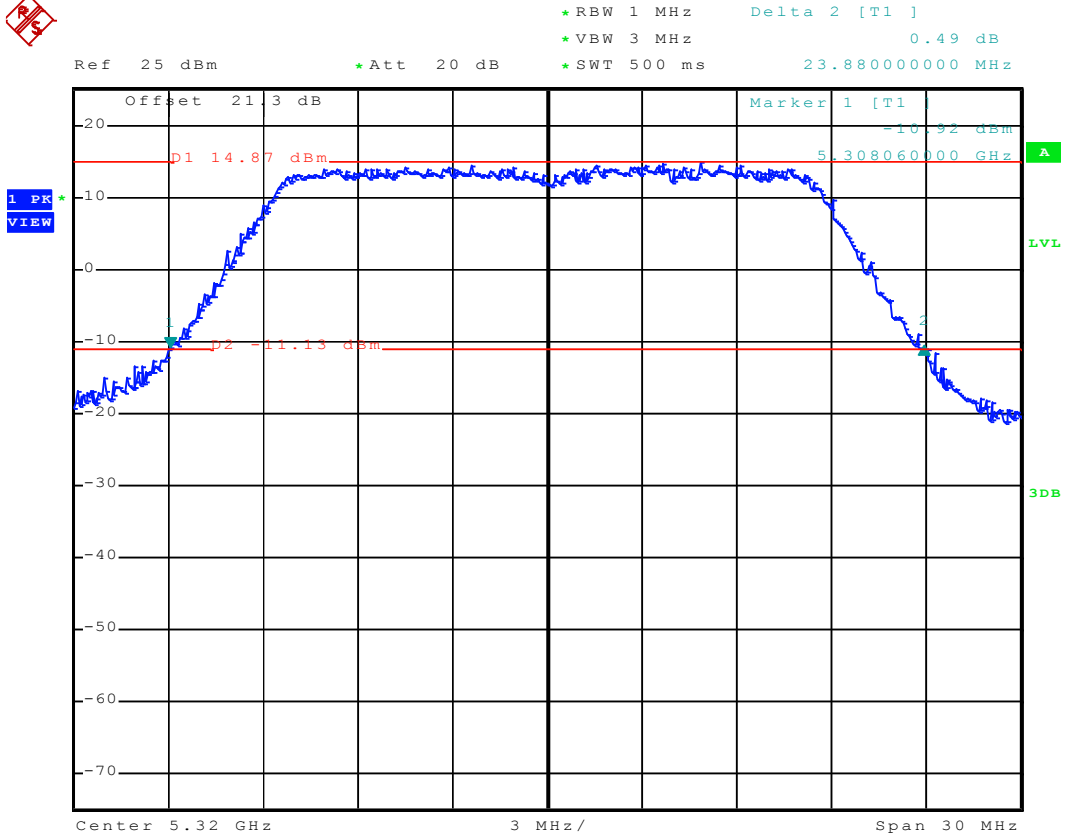

Date: 8.NOV.2007 10:25:35



Mode 13

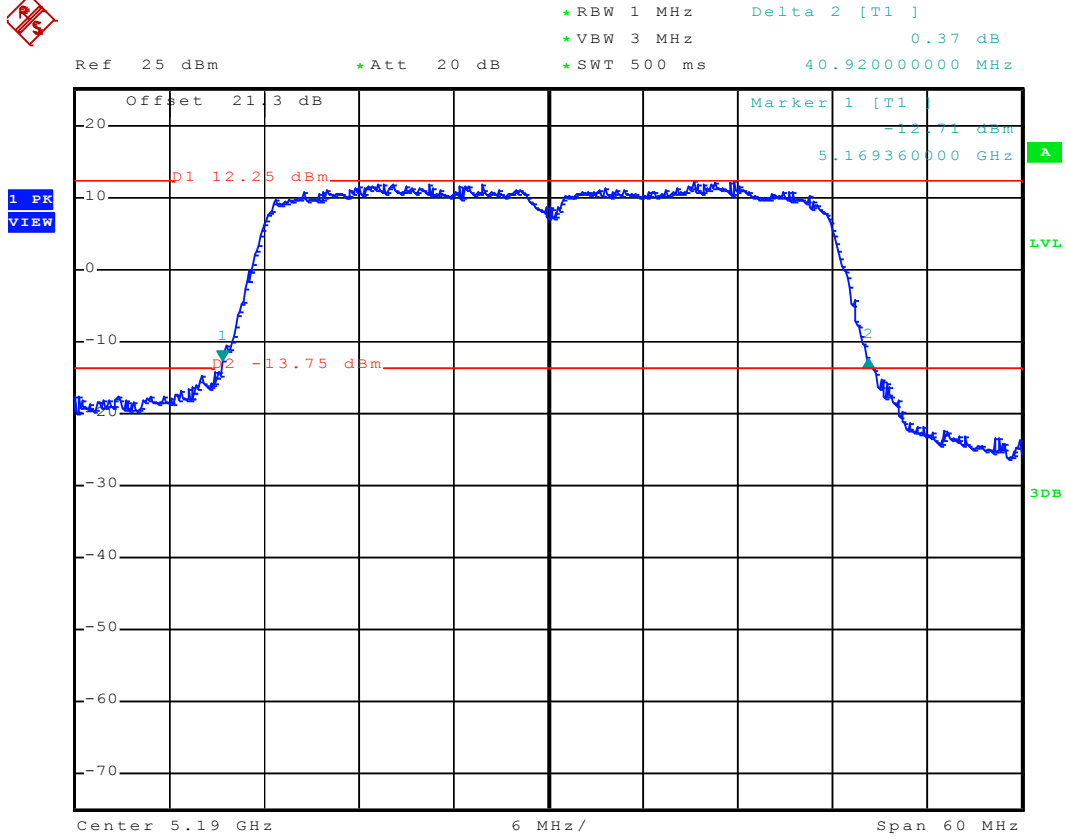

Date: 9.NOV.2007 11:19:30



Mode 14



*RBW 1 MHz Delta 2 [T1]
 *VBW 3 MHz 0.30 dB
 *SWT 500 ms 41.640000000 MHz

Ref 25 dBm

*Att 20 dB

1 PK VIEW

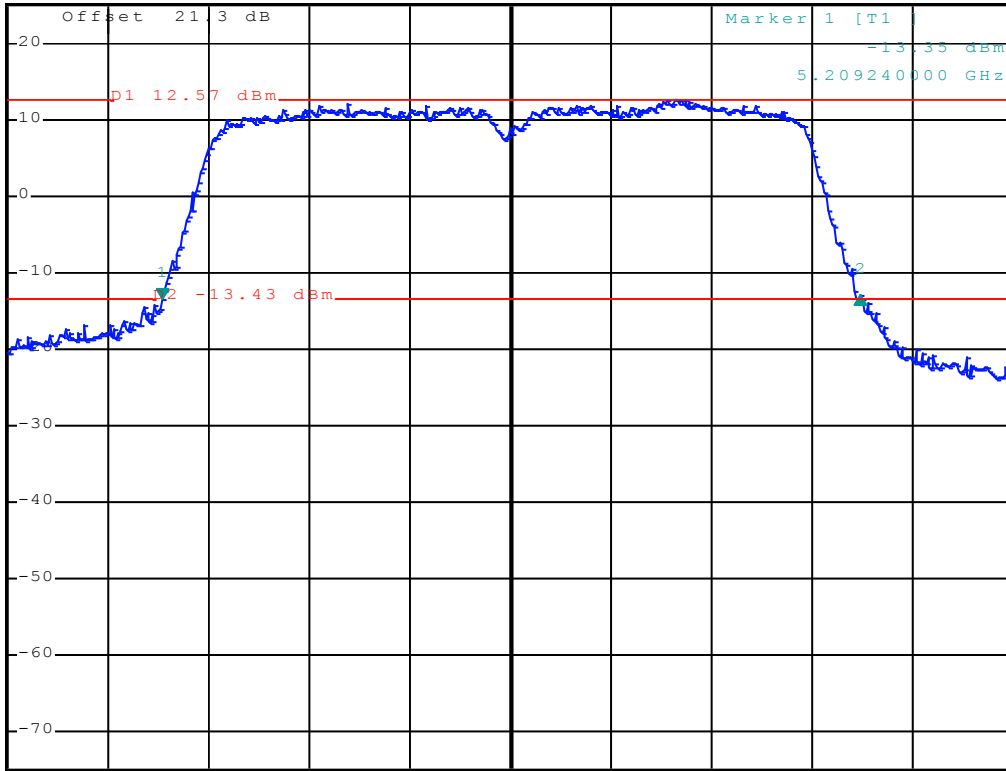

Center 5.23 GHz 6 MHz/ Span 60 MHz

Date: 7.JAN.2008 17:20:37



Mode 15

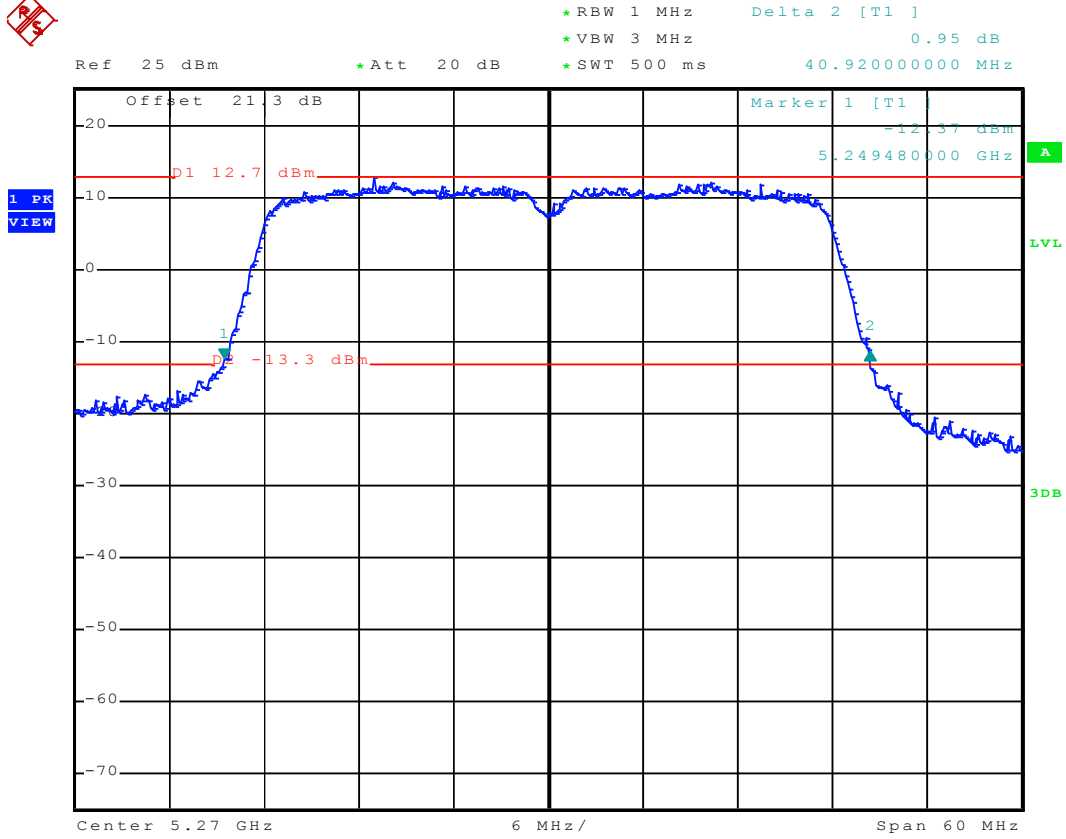

Date: 9.NOV.2007 11:18:22



Mode 16

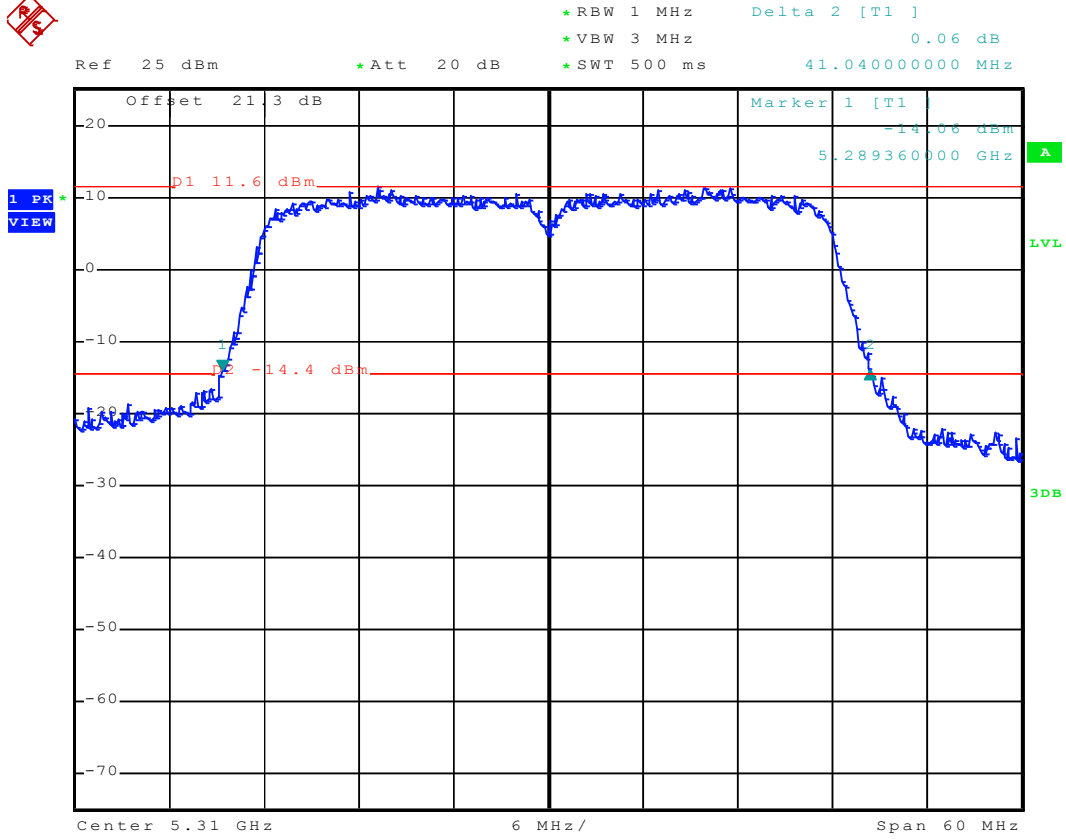

Date: 27.NOV.2007 04:10:49



5.3 Peak Transmit Power

5.3.1 Measuring Instruments

As described in chapter 6 of this test report.

5.3.2 Test Procedure

The transmitter output is connected to the spectrum analyzer. According to the method 3 of DA-02-2138, the resolution bandwidth is set to 1 MHz, video bandwidth is 1MHz, max hold to run for 60 seconds, and sample detection is used. The peak power is measured by channel power integration over the previously measured emissions bandwidth.

5.3.3 Test Setup Layout

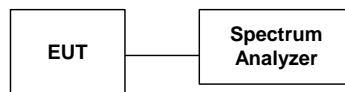



5.3.4 Test Result

- Temperature : 25~26°C
- Relative Humidity : 49~51%
- Test Engineer : CKC

➤ 802.11a Normal mode

Channel	Frequency (MHz)	Measured Output Power (dBm)	Limits (dBm)	Plot Ref. No.
36	5180	16.98	17.00	Mode 1
44	5220	16.90	17.00	Mode 2
48	5240	16.91	17.00	Mode 3
52	5260	17.44	24.00	Mode 4
60	5300	17.86	24.00	Mode 5
64	5320	17.64	24.00	Mode 6

➤ 802.11n(a) BW 20M mode

Channel	Frequency (MHz)	Measured Output Power (dBm)	Limits (dBm)	Plot Ref. No.
36	5180	16.32	17.00	Mode 7
44	5220	16.77	17.00	Mode 8
48	5240	16.67	17.00	Mode 9
52	5260	19.55	24.00	Mode 10
60	5300	19.13	24.00	Mode 11
64	5320	19.11	24.00	Mode 12



➤ 802.11n(a) BW 40M mode

Channel	Frequency (MHz)	Measured Output Power (dBm)	Limits (dBm)	Plot Ref. No.
38	5190	16.82	17.00	Mode 13
46	5230	16.84	17.00	Mode 14
54	5270	16.60	24.00	Mode 15
62	5310	16.81	24.00	Mode 16

Comments :

- 5180MHz 4dBm + 10log(25.38 MHz) = 18.04 dBm for mode 1
- 5220MHz 4dBm + 10log(23.40 MHz) = 17.69 dBm for mode 2
- 5240MHz 4dBm + 10log(23.76 MHz) = 17.76 dBm for Mode 3
- 5260MHz 11dBm + 10log(23.76 MHz) = 24.76 dBm for Mode 4
- 5300MHz 11dBm + 10log(23.28 MHz) = 24.67 dBm for Mode 5
- 5320MHz 11dBm + 10log(24.00 MHz) = 24.80 dBm for Mode 6
- 5180MHz 4dBm + 10log(23.70 MHz) = 17.75 dBm for Mode 7
- 5220MHz 4dBm + 10log(23.94 MHz) = 17.79 dBm for mode 8
- 5240MHz 4dBm + 10log(23.58 MHz) = 17.73 dBm for Mode 9
- 5260MHz 11dBm + 10log(23.64 MHz) = 24.74 dBm for Mode 10
- 5300MHz 11dBm + 10log(24.00 MHz) = 24.80 dBm for Mode 11
- 5320MHz 11dBm + 10log(23.88 MHz) = 24.78 dBm for Mode 12
- 5190MHz 4dBm + 10log(40.92 MHz) = 20.12 dBm for Mode 13
- 5230MHz 4dBm + 10log(41.64 MHz) = 20.20 dBm for Mode 14
- 5270MHz 11dBm + 10log(40.92 MHz) = 27.12 dBm for Mode 15
- 5310MHz 11dBm + 10log(41.04 MHz) = 27.13 dBm for Mode 16



5.3.5 Test Data

Mode 1

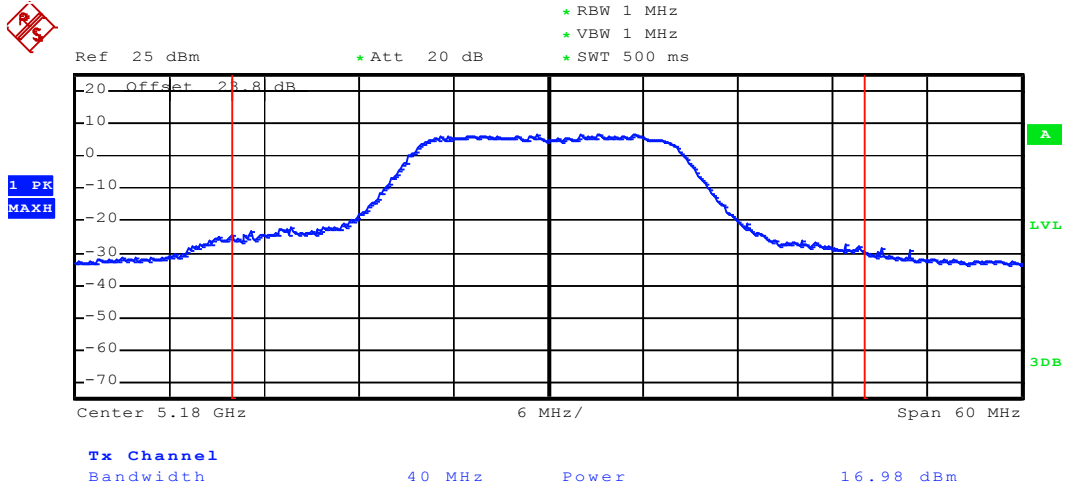

Date: 9.NOV.2007 16:12:34



Mode 2

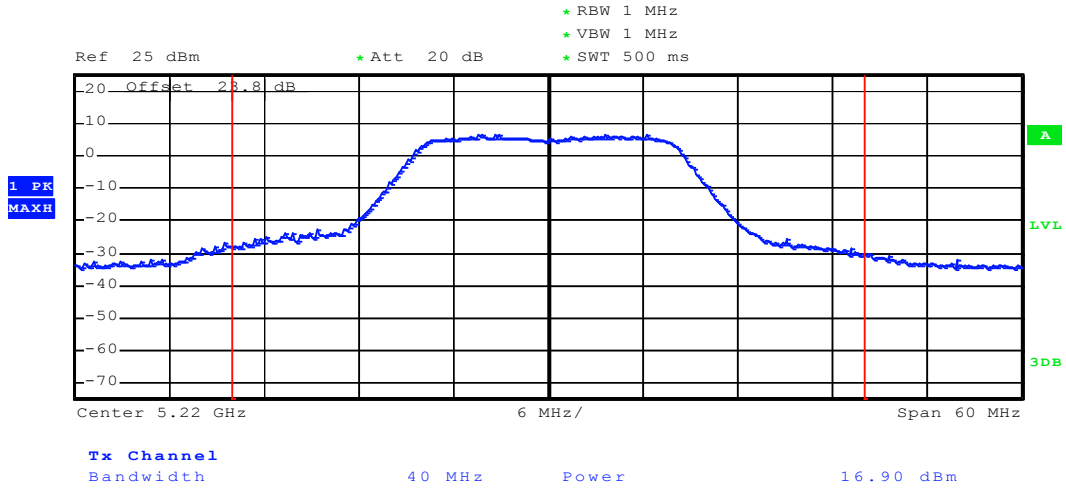

Date: 5 JAN 2008 00:38:45



Mode 3

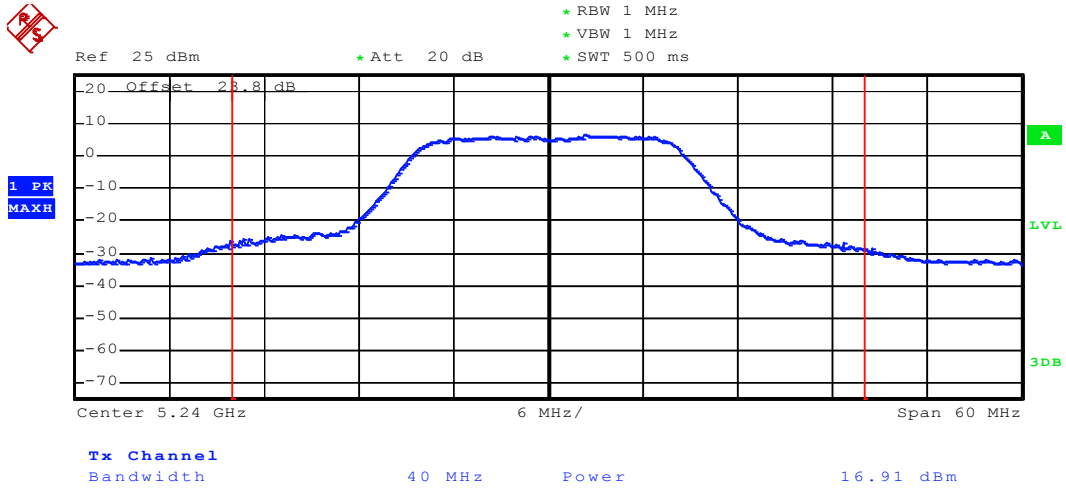

Date: 9.NOV.2007 16:18:58



Mode 4

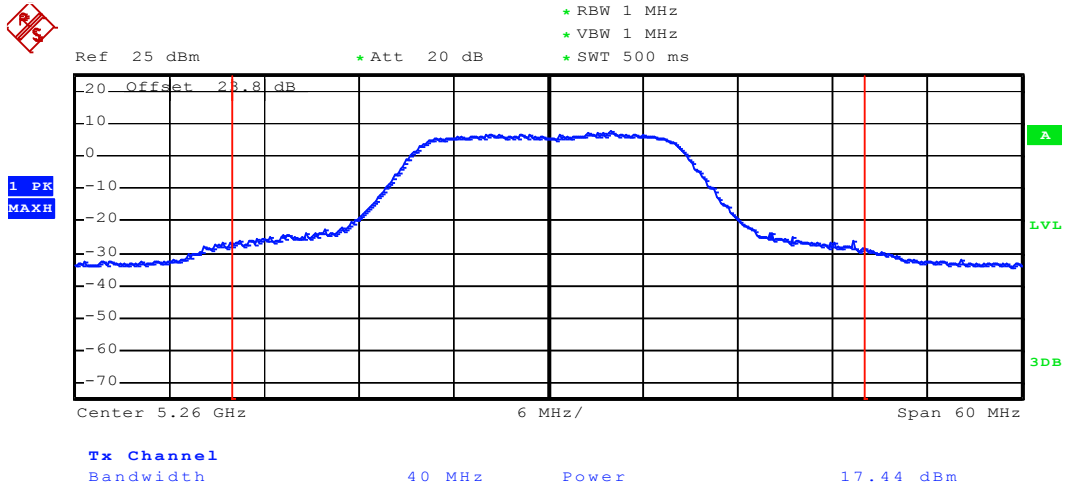

Date: 9.NOV.2007 16:19:53



Mode 5

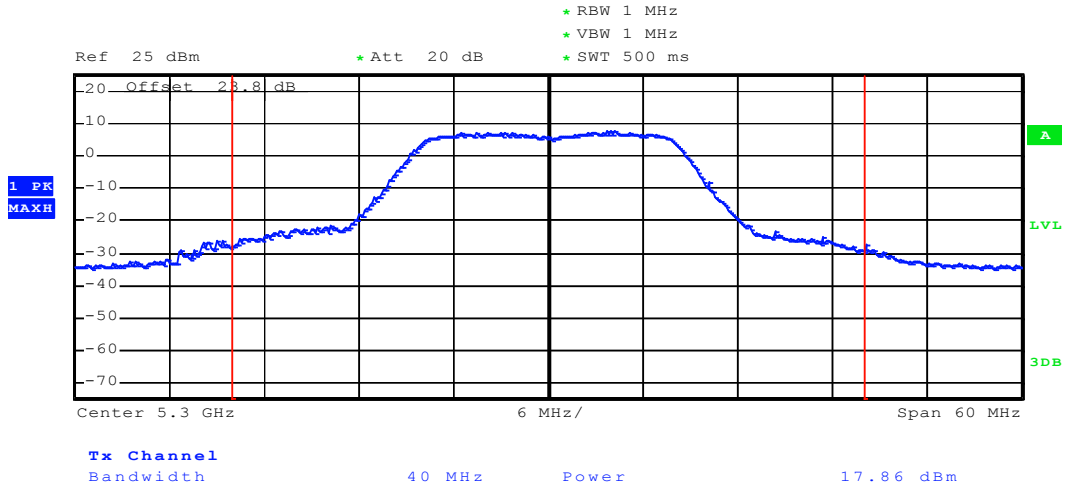

Date: 5 JAN 2008 00:39:41



Mode 6

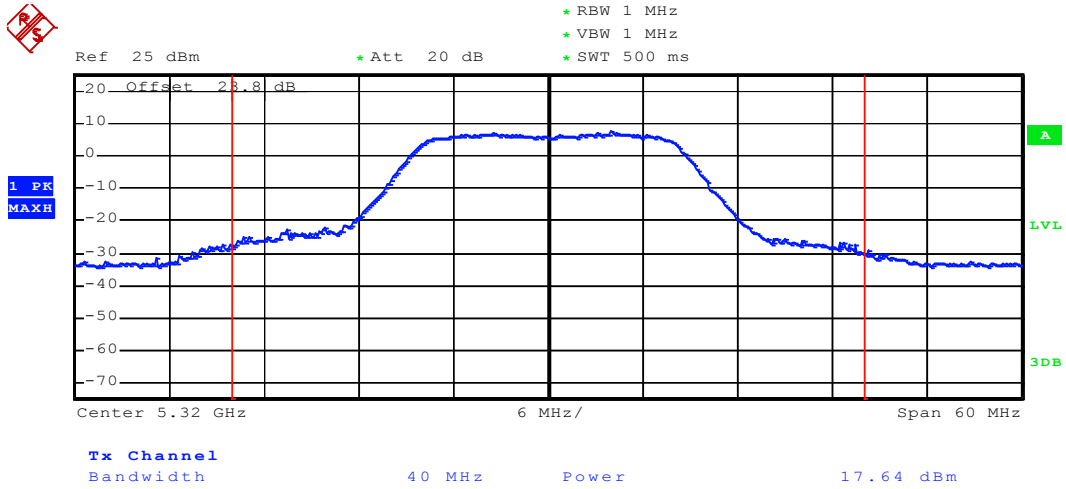

Date: 9.NOV.2007 16:20:49



Mode 7

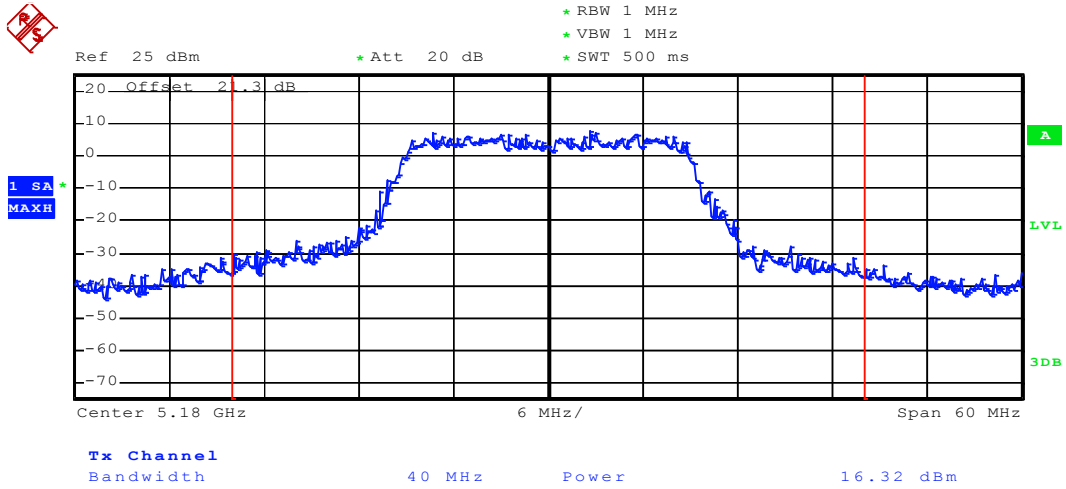

Date: 9.NOV.2007 10:43:05



Mode 8



* RBW 1 MHz
* VBW 1 MHz
* SWT 500 ms

Ref 25 dBm

* Att 20 dB

1 SA
MAXH

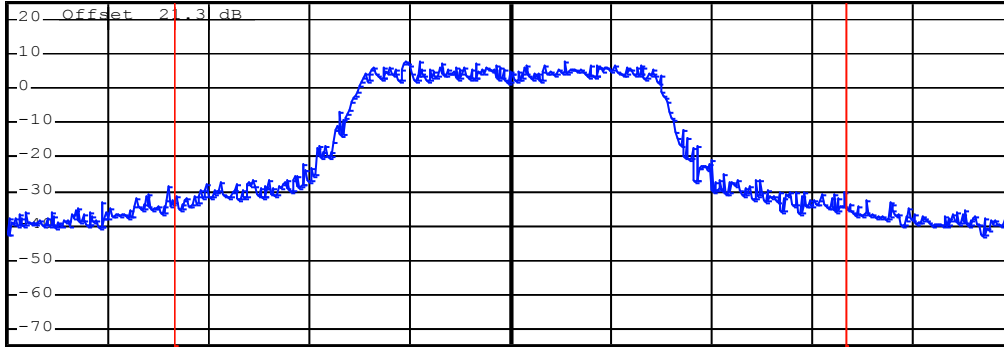

Center 5.22 GHz

6 MHz/

Span 60 MHz

Tx Channel

Bandwidth

40 MHz

Power

16.77 dBm

Date: 7.JAN.2008 17:57:07



Mode 9

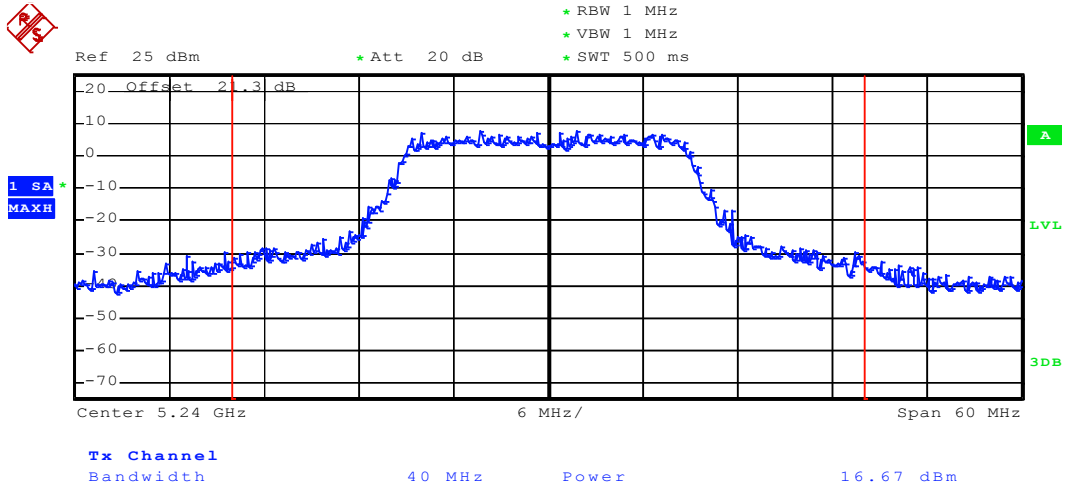

Date: 9.NOV.2007 10:42:33



Mode 10

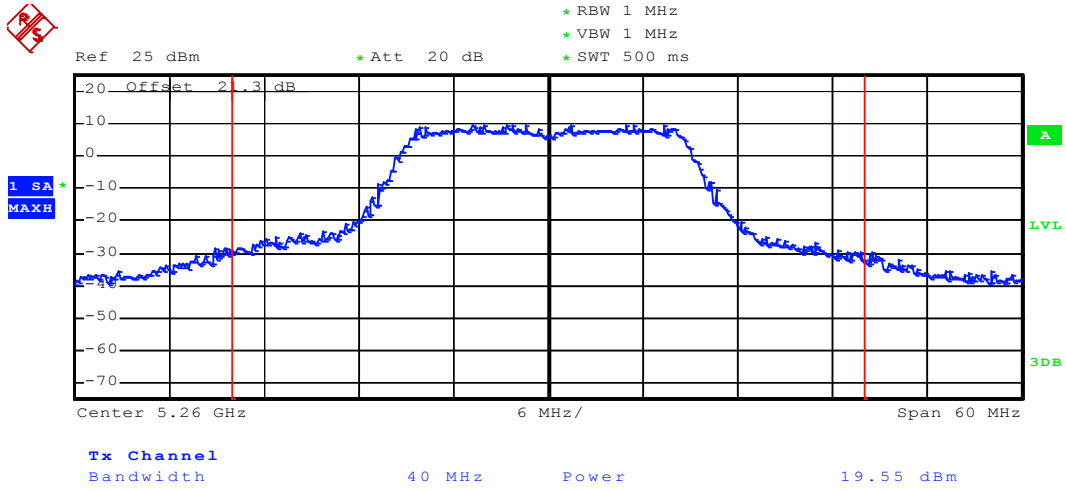

Date: 9.NOV.2007 10:45:20



Mode 11



* RBW 1 MHz
* VBW 1 MHz
* SWT 500 ms

Ref 25 dBm

* Att 20 dB

1 SA
MAXH

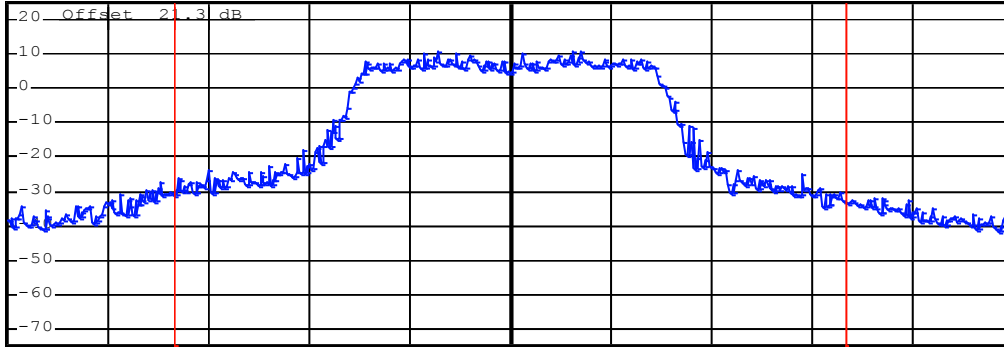

Tx Channel
Bandwidth

40 MHz

Power

19.13 dBm

Date: 7.JAN.2008 17:56:04



Mode 12

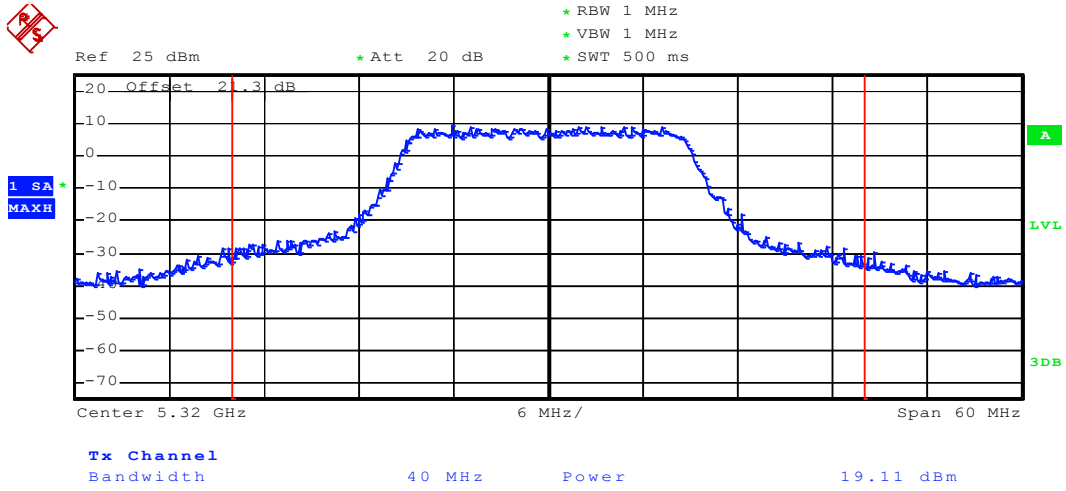

Date: 9.NOV.2007 10:47:09



Mode 13

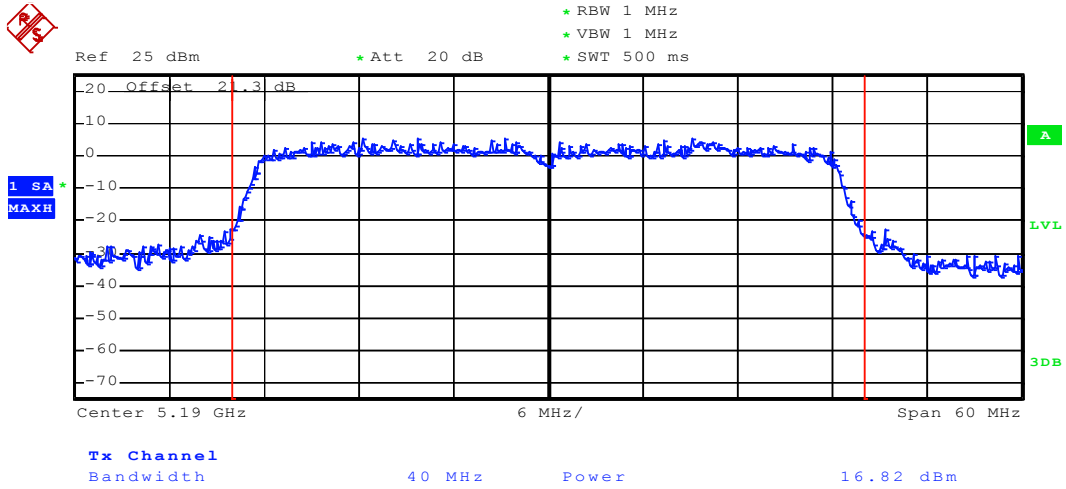

Date: 9.NOV.2007 10:51:40



Mode 14



* RBW 1 MHz
* VBW 1 MHz
* SWT 500 ms

Ref 25 dBm

* Att 20 dB

1 SA
MAXH

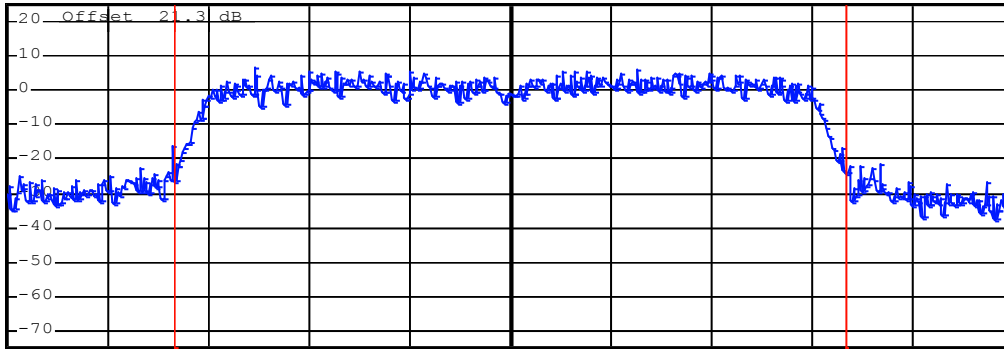

Center 5.23 GHz

6 MHz/

Span 60 MHz

Tx Channel
Bandwidth

40 MHz

Power

16.84 dBm

Date: 7.JAN.2008 17:30:42



Mode 15

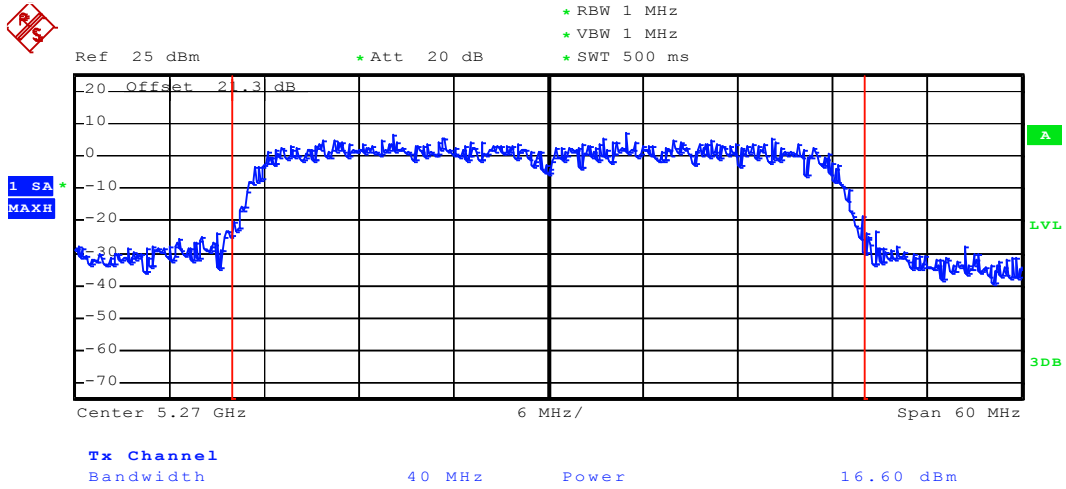

Date: 9.NOV.2007 10:52:44



Mode 16

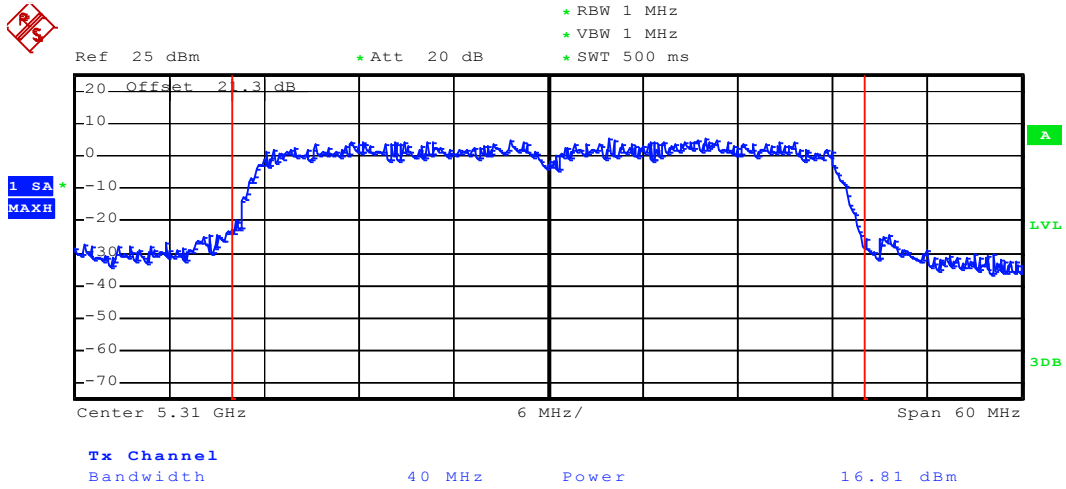

Date: 9.NOV.2007 10:54:23



5.4 Peak Power Spectral Density

5.4.1 Measuring Instruments

As described in chapter 6 of this test report.

5.4.2 Test Procedure

The transmitter output is connected to the spectrum analyzer. According to the method 3 of DA-02-2138, the resolution bandwidth is set to 1 MHz, video bandwidth is 3MHz, trace average 100 traces in power averaging mode, and sample detection is used, and the analyzer is set for video averaging.

5.4.3 Test Setup Layout

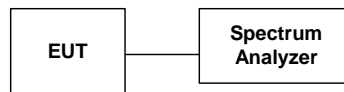



5.4.4 Test Result

- Temperature : 25~26°C
- Relative Humidity :
- Test Engineer : CKC

➤ 802.11a Normal mode

Channel	Frequency (MHz)	Power Spectral Density (dBm)	Limits (dBm)	Plot Ref. No.
36	5180	-8.50	4	Mode 1
44	5220	-8.99	4	Mode 2
48	5240	-10.17	4	Mode 3
52	5260	-8.93	11	Mode 4
60	5300	-7.96	11	Mode 5
64	5320	-7.90	11	Mode 6

➤ 802.11n(a) BW 20M mode

Channel	Frequency (MHz)	Power Spectral Density (dBm)	Limits (dBm)	Plot Ref. No.
36	5180	-3.54	4	Mode 7
44	5220	-4.37	4	Mode 8
48	5240	-3.00	4	Mode 9
52	5260	-3.37	11	Mode 10
60	5300	-3.36	11	Mode 11
64	5320	-2.99	11	Mode 12



➤ 802.11n(a) BW 40M mode

Channel	Frequency (MHz)	Power Spectral Density (dBm)	Limits (dBm)	Plot Ref. No.
38	5190	-12.42	4	Mode 13
46	5230	-12.30	4	Mode 14
54	5270	-11.66	11	Mode 15
62	5310	-12.72	11	Mode 16



5.4.5 Test Data

Mode 1

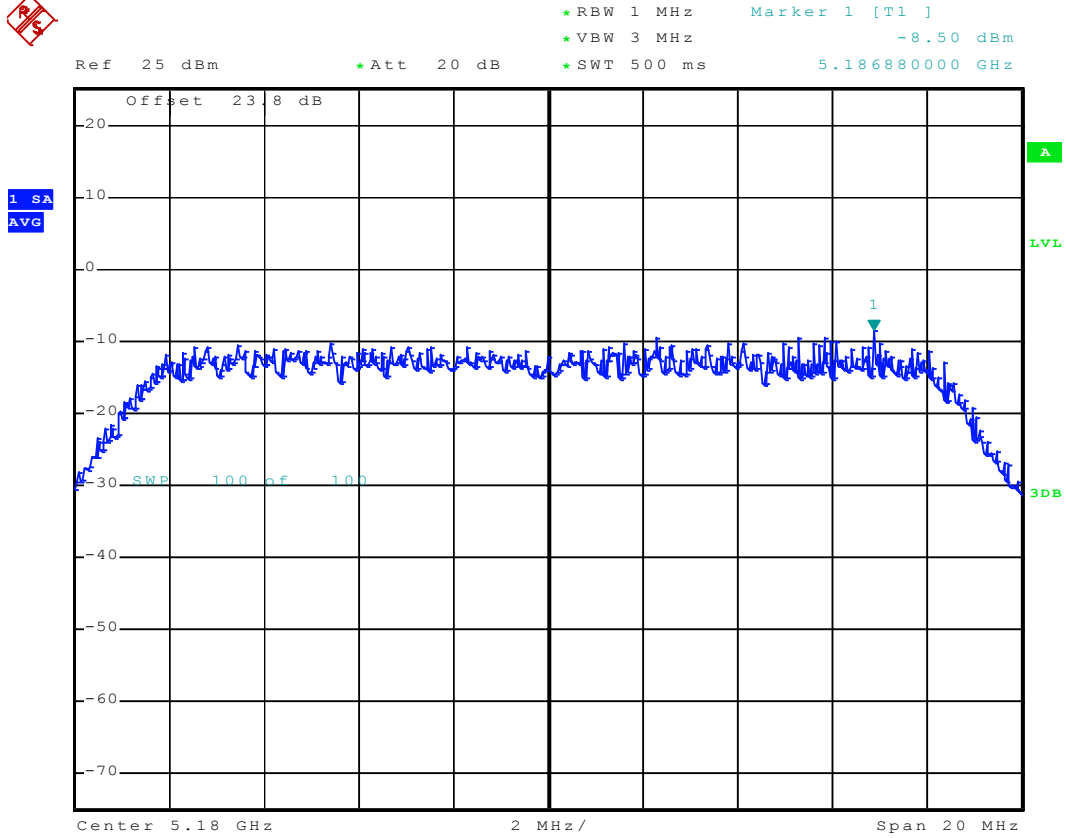

Date: 22.NOV.2007 00:38:46



Mode 2

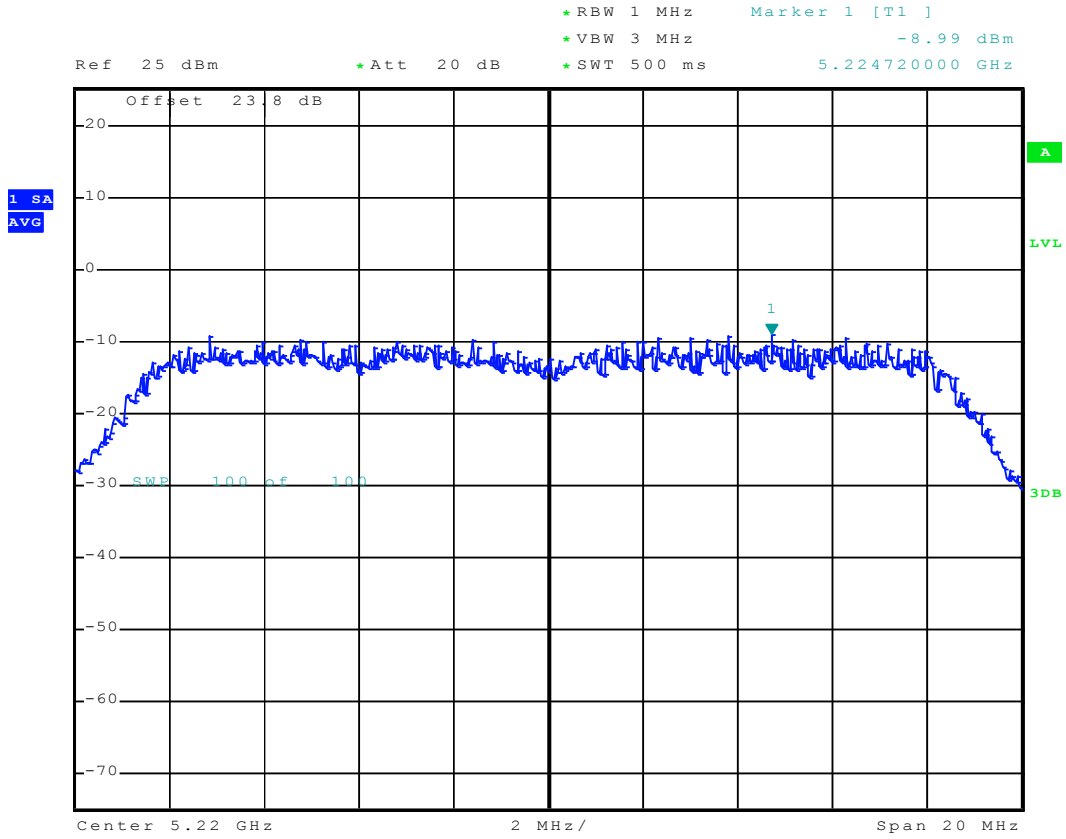

Date: 5 JAN 2008 00:09:04



Mode 3

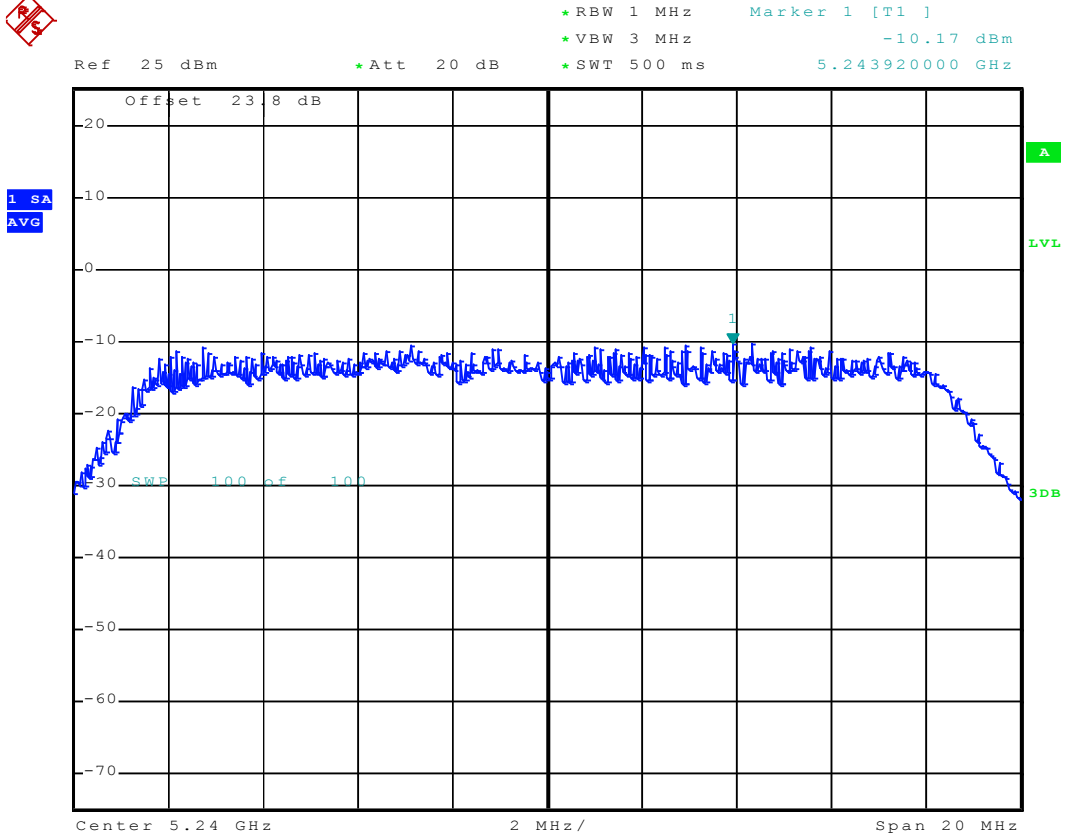

Date: 22.NOV.2007 00:20:57



Mode 4

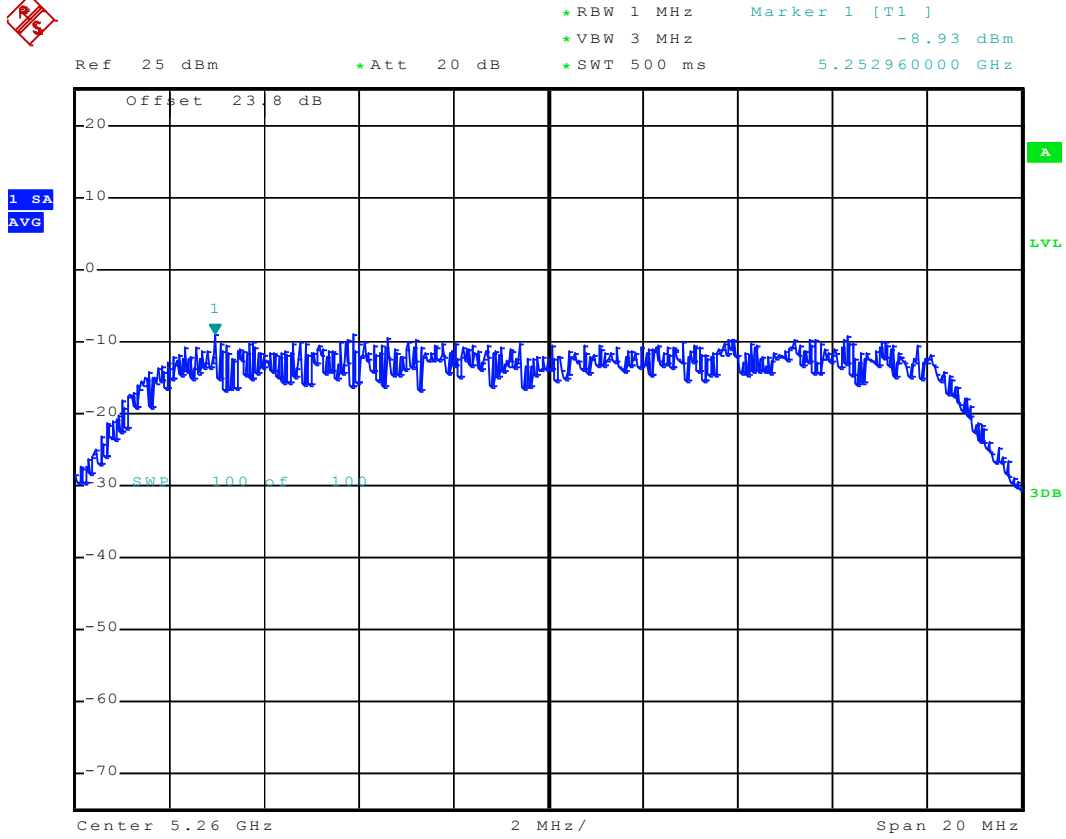

Date: 22.NOV.2007 00:18:47



Mode 5

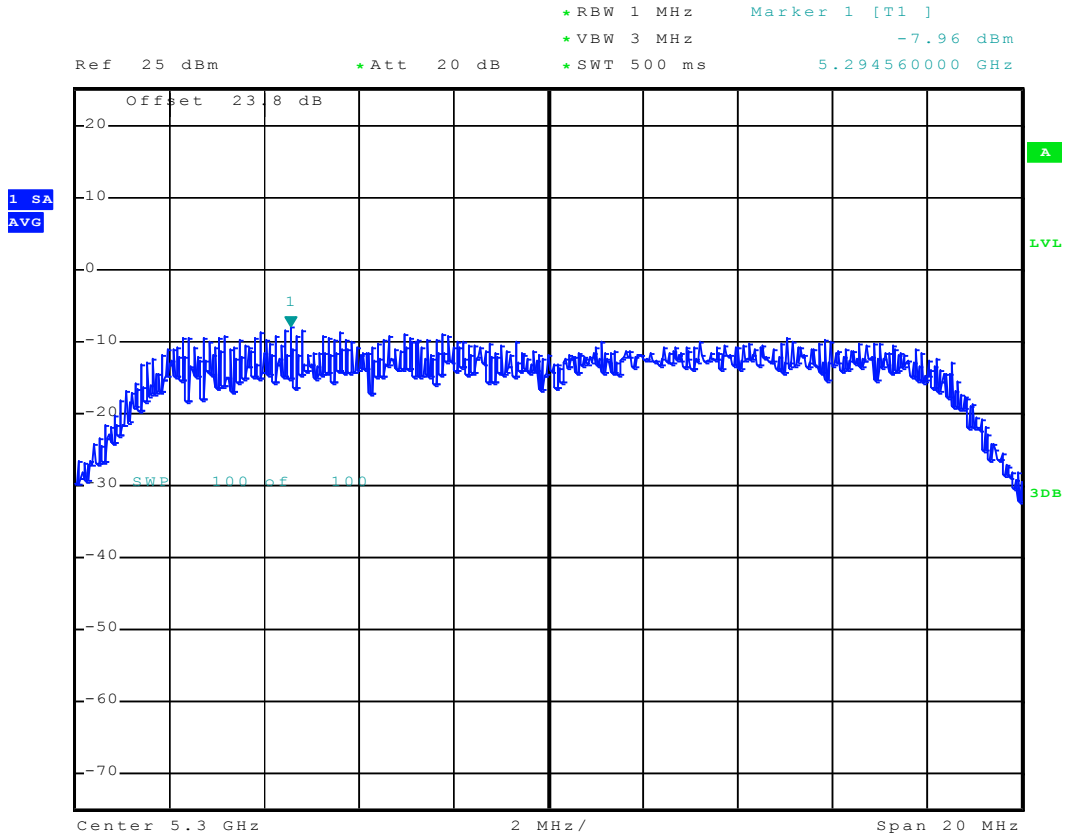

Date: 5 JAN 2008 00:12:53



Mode 6

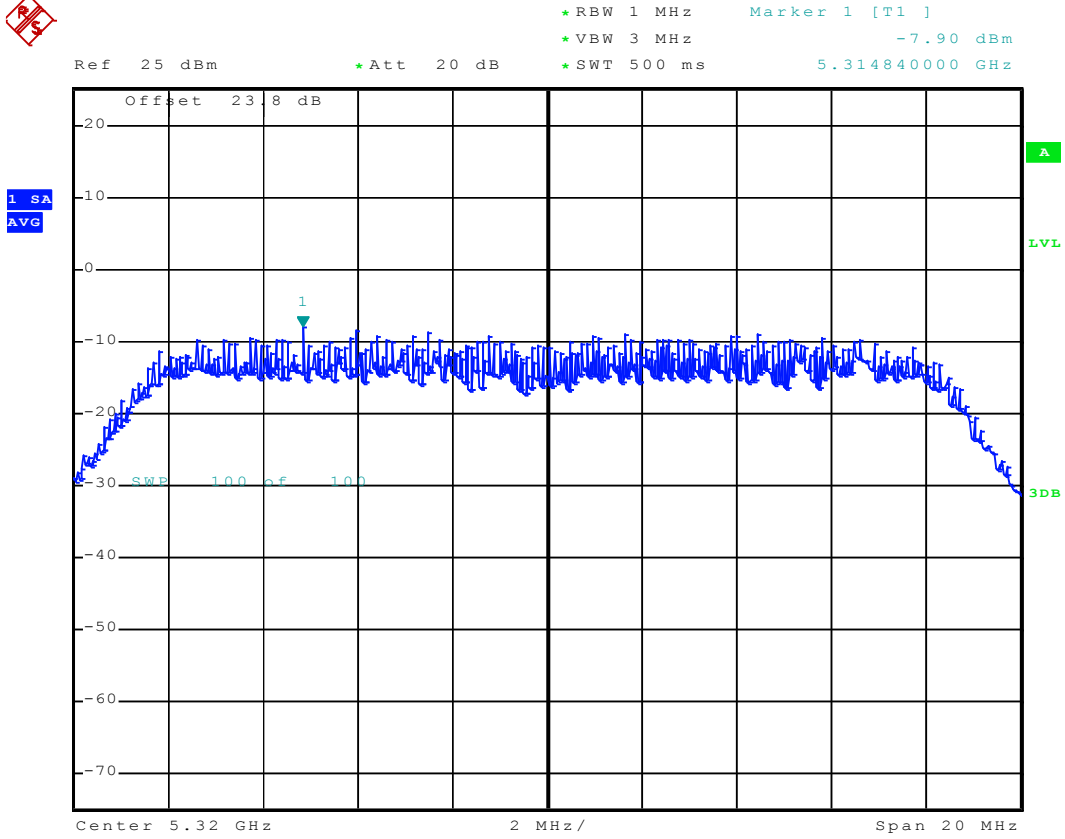

Date: 22.NOV.2007 00:16:41



Mode 7

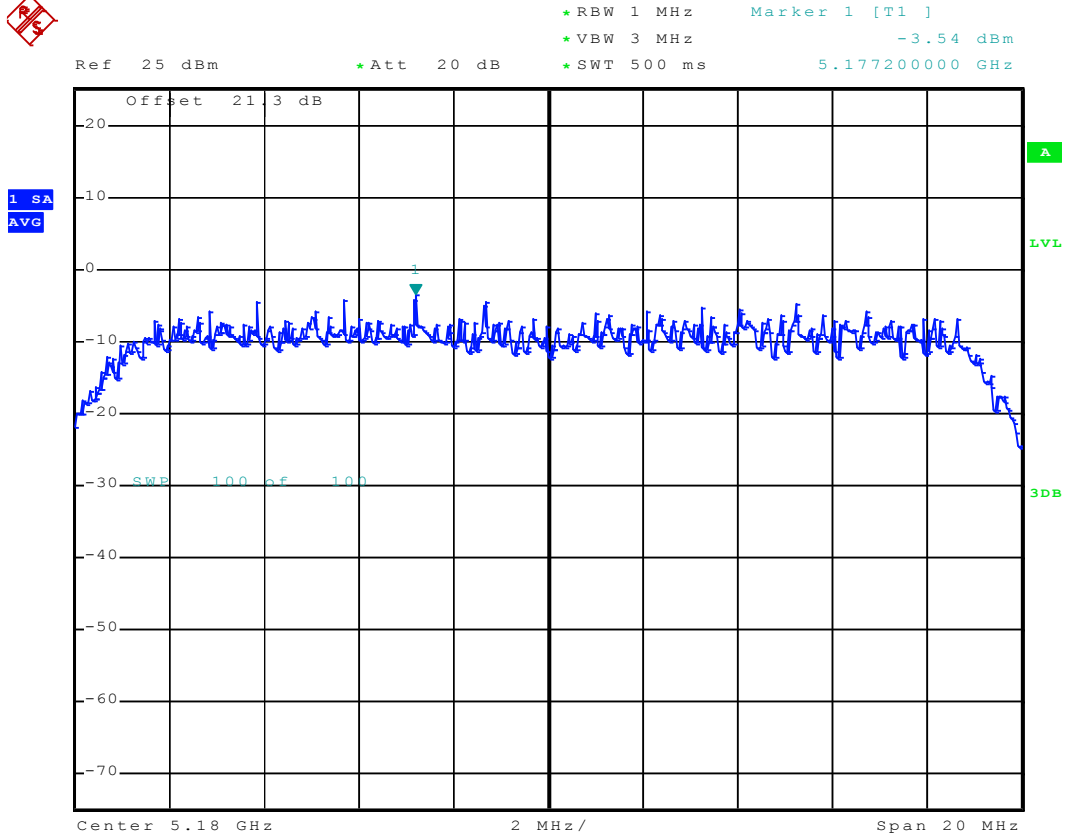

Date: 22.NOV.2007 01:28:37



Mode 8



*RBW 1 MHz Marker 1 [T1]
 *VBW 3 MHz -4.37 dBm
 *SWT 500 ms 5.217720000 GHz

Ref 25 dBm

*Att 20 dB

1 SA
AVG

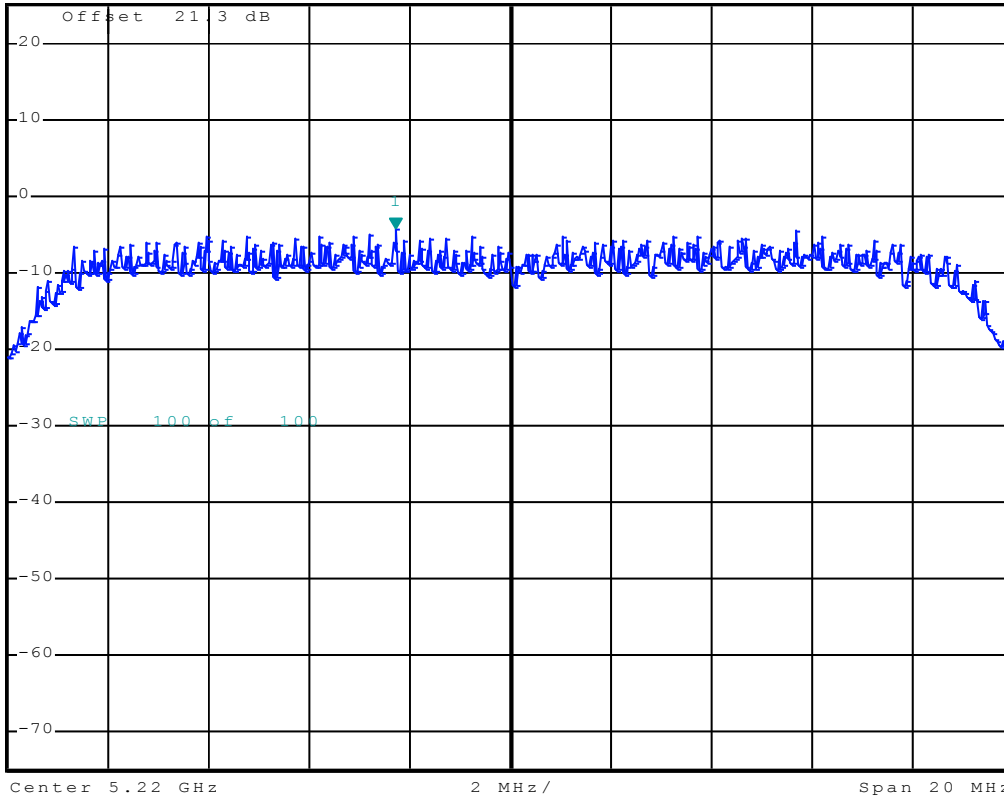

Date: 7.JAN.2008 17:59:00



Mode 9

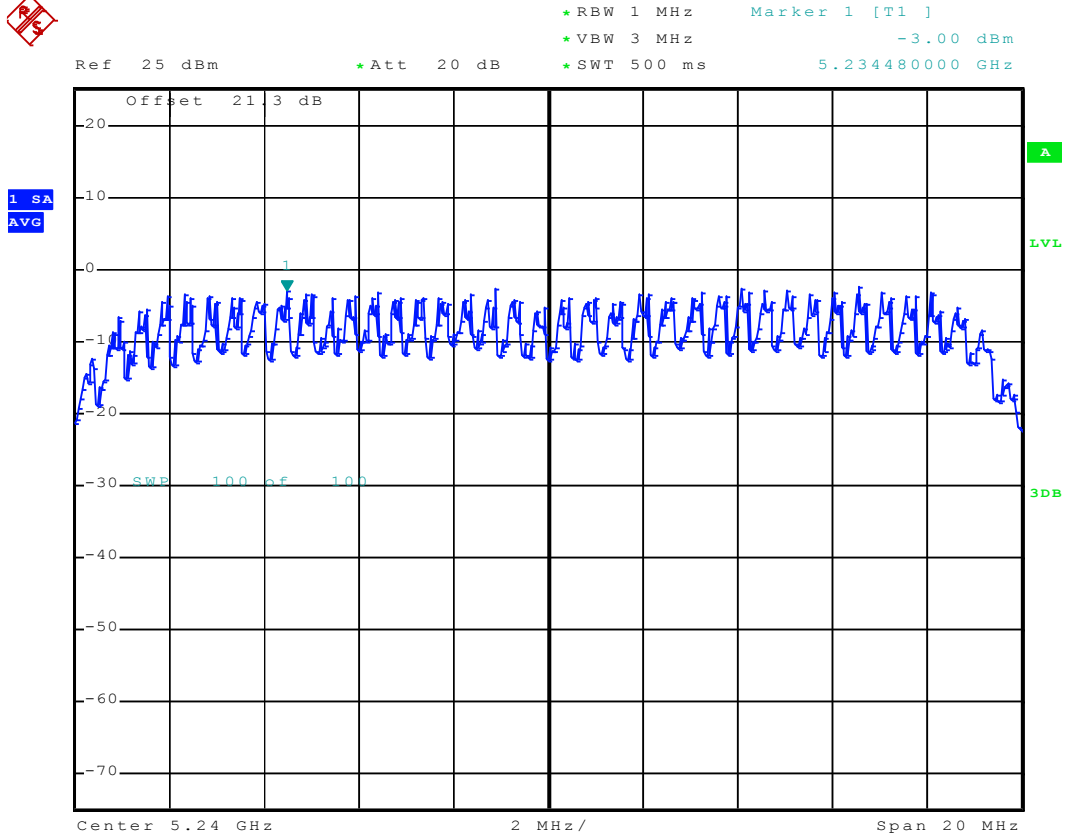

Date: 8.NOV.2007 13:23:59



Mode 10

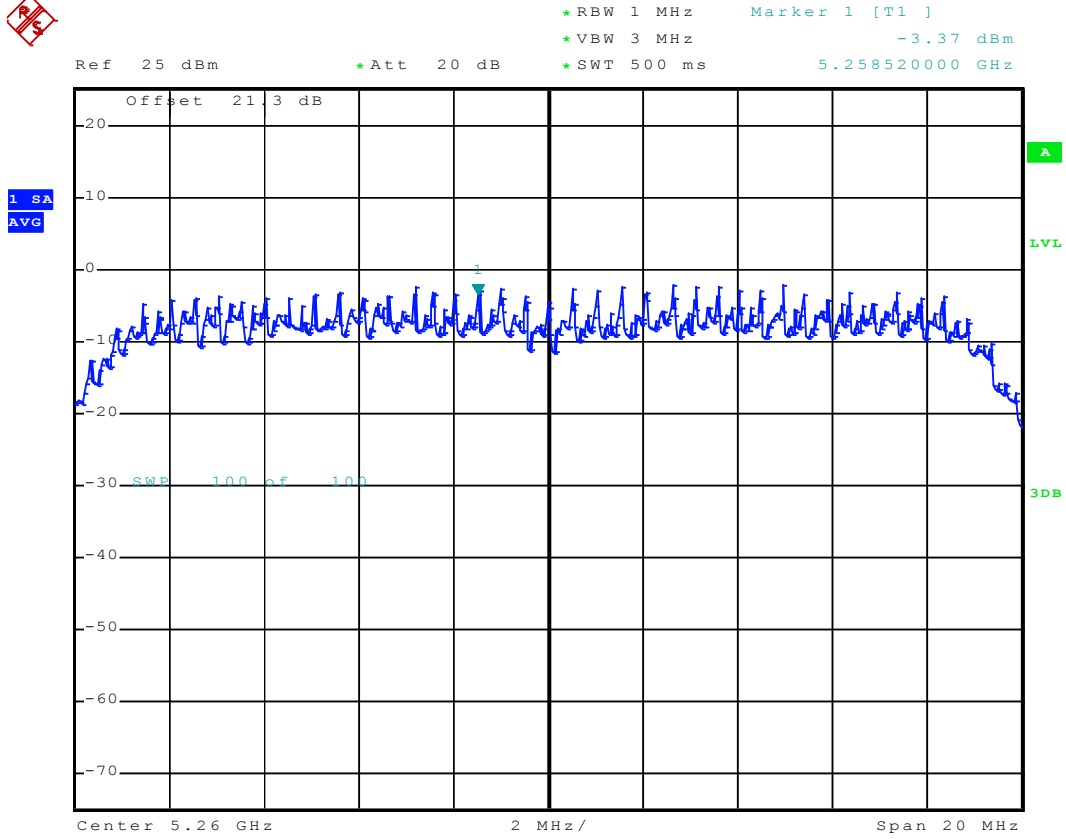

Date: 9.NOV.2007 10:05:07



Mode 11



Ref 25 dBm *Att 20 dB *RBW 1 MHz Marker 1 [T1]
*VBW 3 MHz -3.36 dBm
*SWT 500 ms 5.294760000 GHz

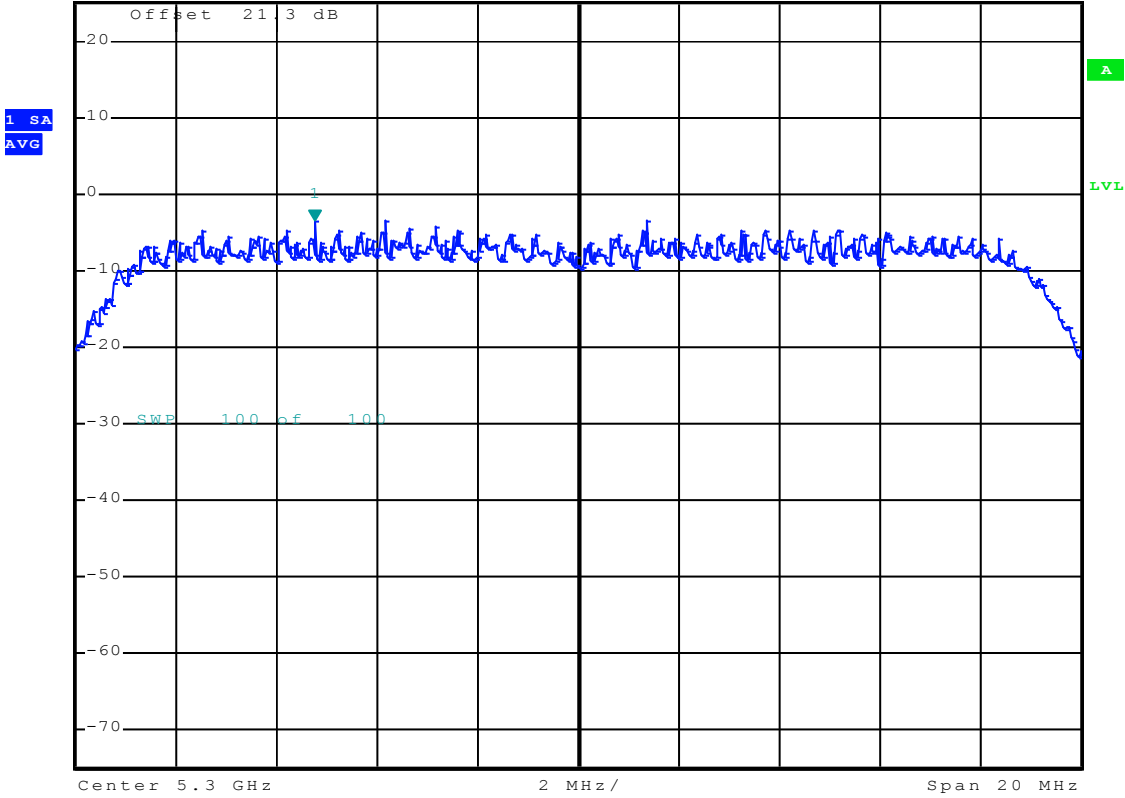

Date: 7.JAN.2008 18:03:43



Mode 12

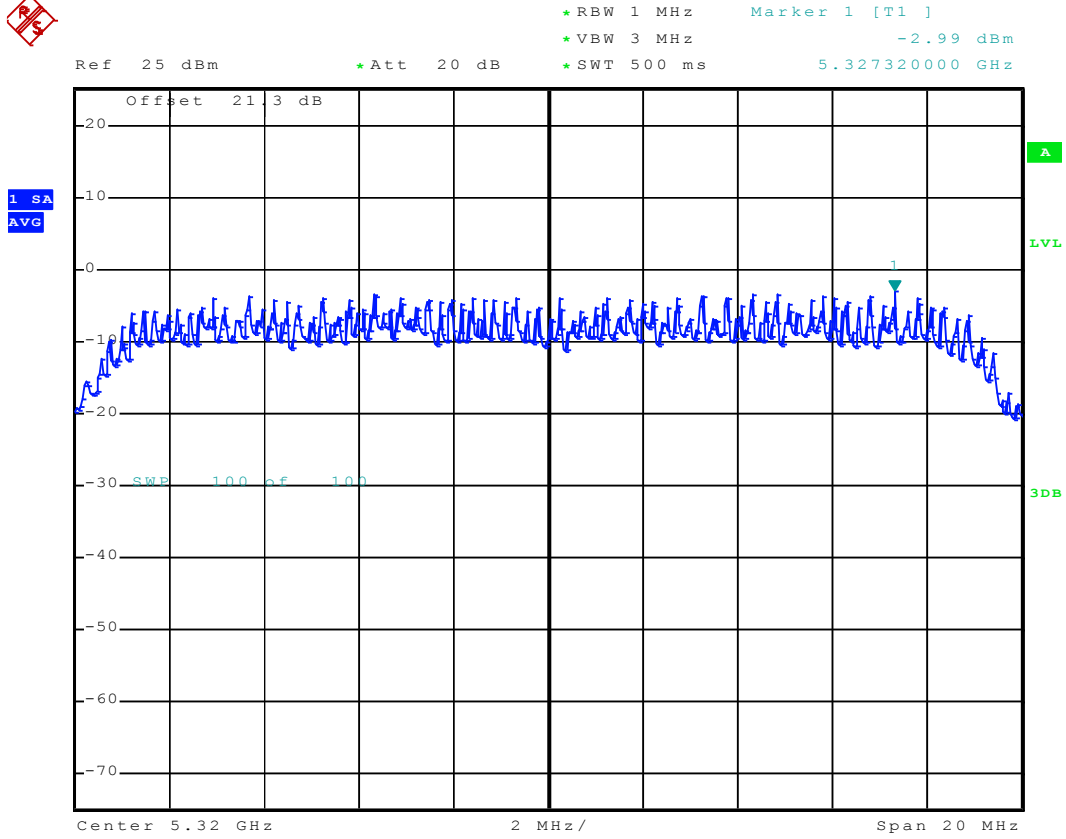

Date: 8.NOV.2007 13:37:10



Mode 13

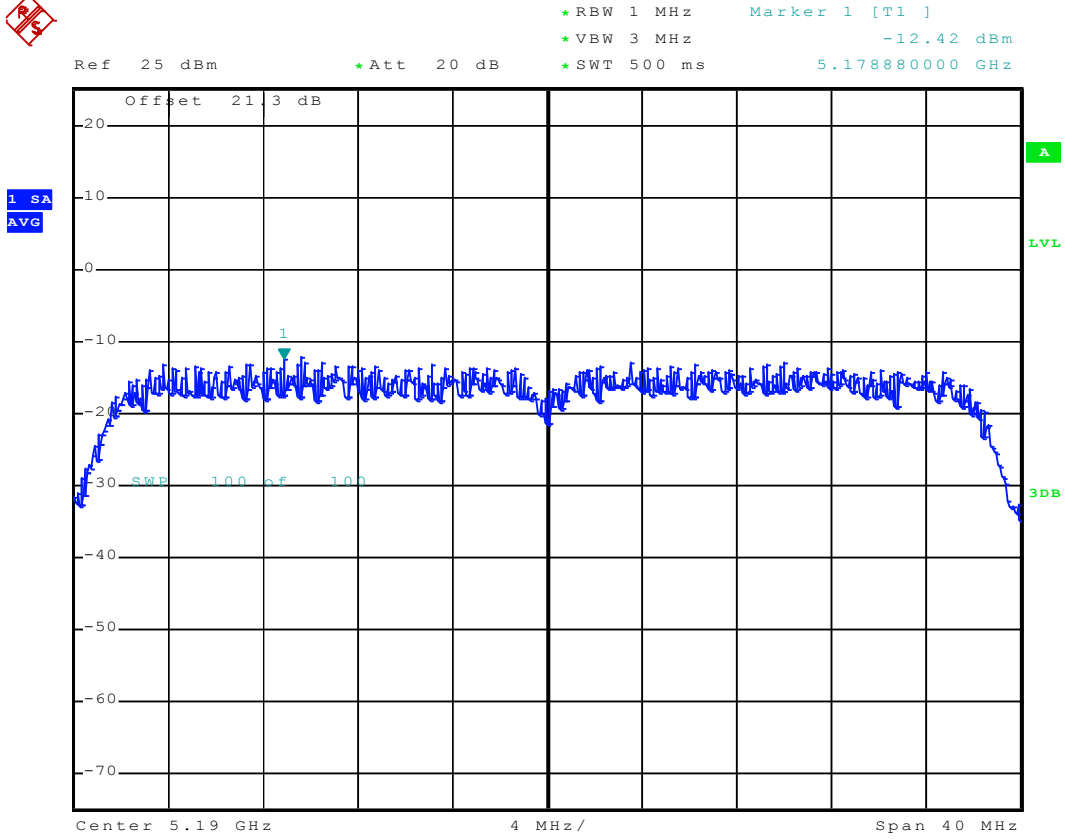

Date: 9.NOV.2007 10:32:34



Mode 14



*RBW 1 MHz Marker 1 [T1]
 *VBW 3 MHz -12.30 dBm
 *SWT 500 ms 5.241520000 GHz

Ref 25 dBm

*Att 20 dB

1 SA
AVG

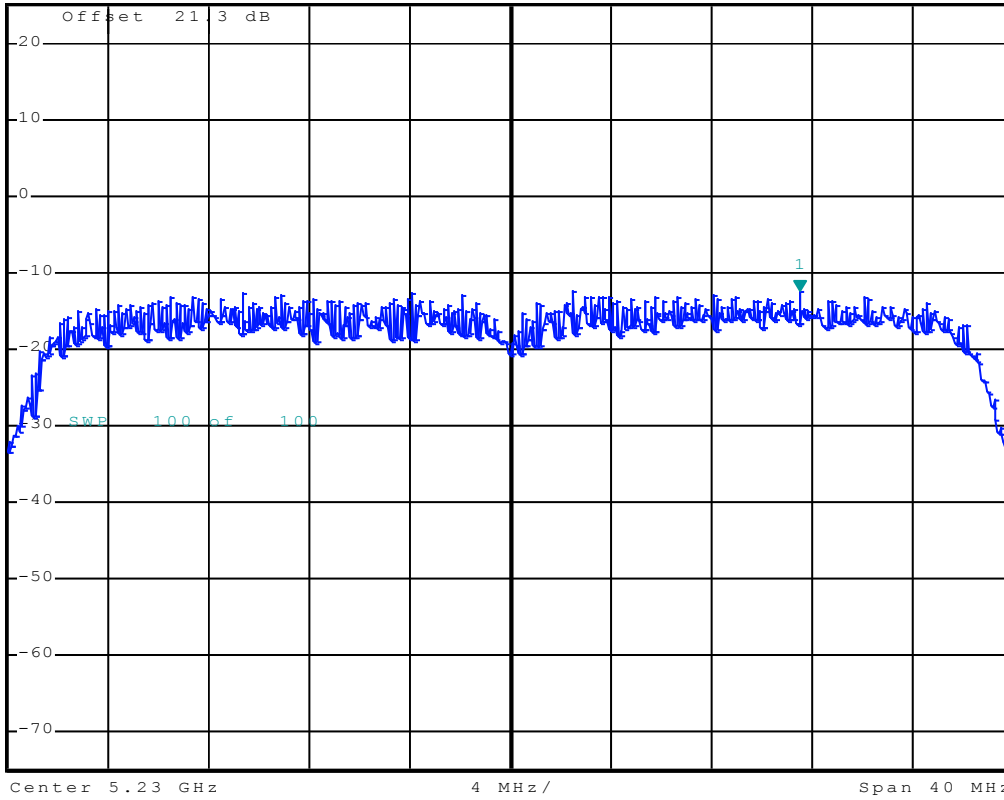

Date: 7.JAN.2008 17:36:09



Mode 15

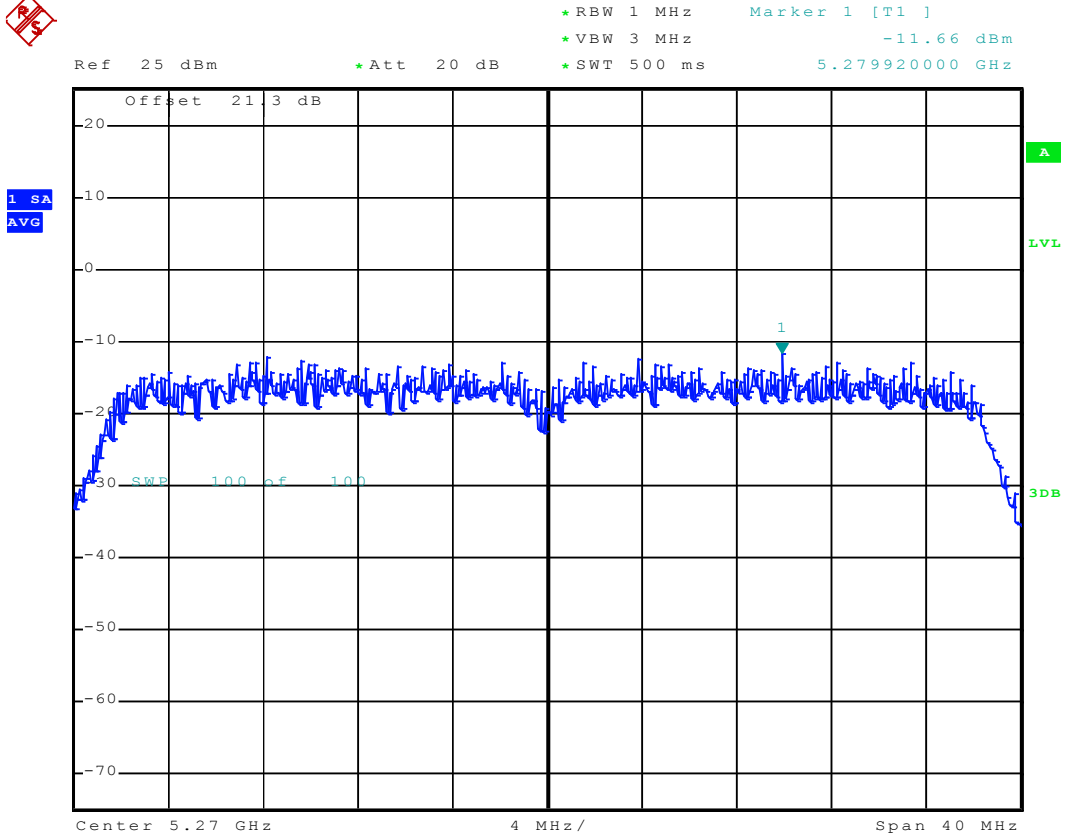

Date: 9.NOV.2007 10:10:38



Mode 16

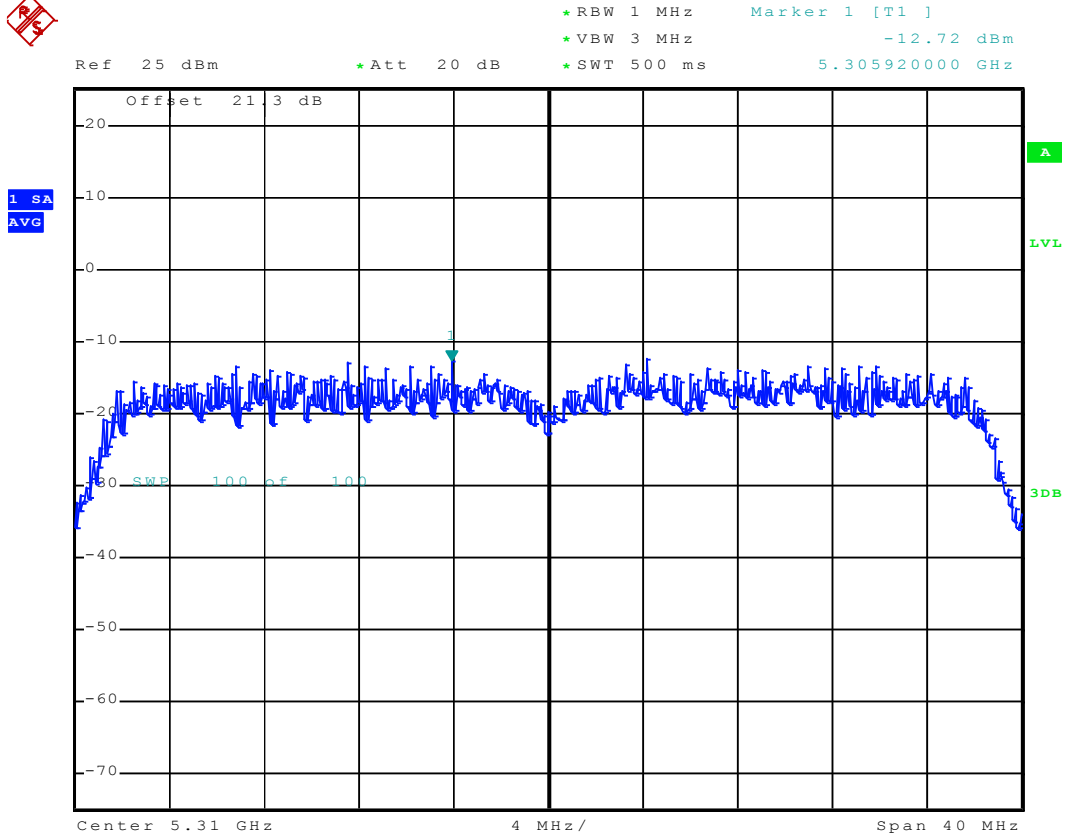

Date: 9.NOV.2007 10:18:28



5.5 Test of Conducted Emission

As described in chapter 6 of this test report.

5.5.1 Test Procedures

- a. The EUT was placed 0.4 meter from the conducting wall of the shielding room was kept at least 80 centimeters from any other grounded conducting surface.
- b. Connect EUT to the power port of a line impedance stabilization network (LISN).
- c. All the support units are connected to the other LISN.
- d. The LISN provides 50 ohm coupling impedance for the measuring instrument.
- e. The FCC states that a 50 ohm, 50 microhenry LISN should be used.
- f. Both sides of AC line were checked for maximum conducted interference.
- g. The frequency range from 150 kHz to 30 MHz was searched.
- h. Set the test-receiver system to Peak Detect Function and specified bandwidth with Maximum Hold Mode.



5.5.2 Test Data

- Frequency Range of Test : 150kHz to 30 MHz
- Test Mode : Mode 1
- Temperature : 25~26°C
- Relative Humidity : 49~51%
- Test Engineer : CKC

The test that passed at minimum margin was marked by the frame in the following table.

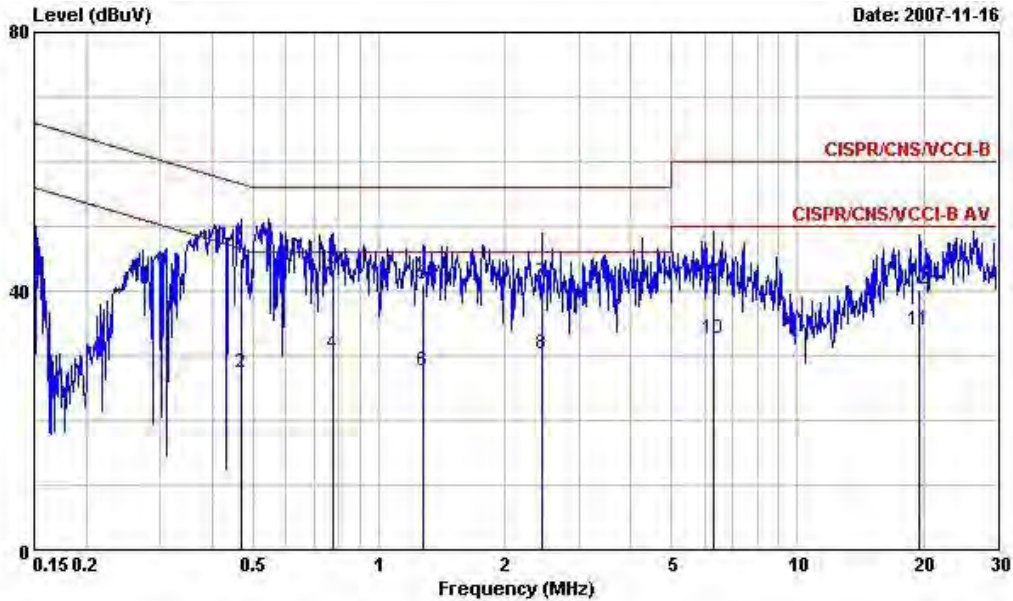

Site : CO04-HY
 Condition : CISPR/CNS/VCCI-B LISN 200704 99041 LINE
 EUT : N/B
 POWER: 120V/60Hz
 Model : FR701819
 Memo : WLAN Link+BT Link+Adaptor

	Over	Limit	Read	LISN	Cable		
Freq	Level	Limit	Line	Level	Factor	Loss	
MHz	dBuV	dB	dBuV	dBuV	dB	dB	
1 @ 0.4686110	45.06	-11.48	56.54	44.28	0.10	0.68	QP
2 @ 0.4686110	27.40	-19.14	46.54	26.62	0.10	0.68	Average
3 @ 0.7751940	43.30	-12.70	56.00	42.68	0.10	0.52	QP
4 @ 0.7751940	30.23	-15.77	46.00	29.61	0.10	0.52	Average
5 @ 1.280	41.04	-14.96	56.00	40.50	0.10	0.44	QP
6 @ 1.280	27.56	-18.44	46.00	27.02	0.10	0.44	Average
7 @ 2.460	41.28	-14.72	56.00	40.78	0.10	0.40	QP
8 @ 2.460	30.33	-15.67	46.00	29.83	0.10	0.40	Average
9 @ 6.290	41.15	-18.85	60.00	40.73	0.15	0.27	QP
10 @ 6.290	32.76	-17.24	50.00	32.34	0.15	0.27	Average
11 @ 19.530	33.87	-16.13	50.00	33.59	0.23	0.05	Average
12 @ 19.530	40.17	-19.83	60.00	39.89	0.23	0.05	QP

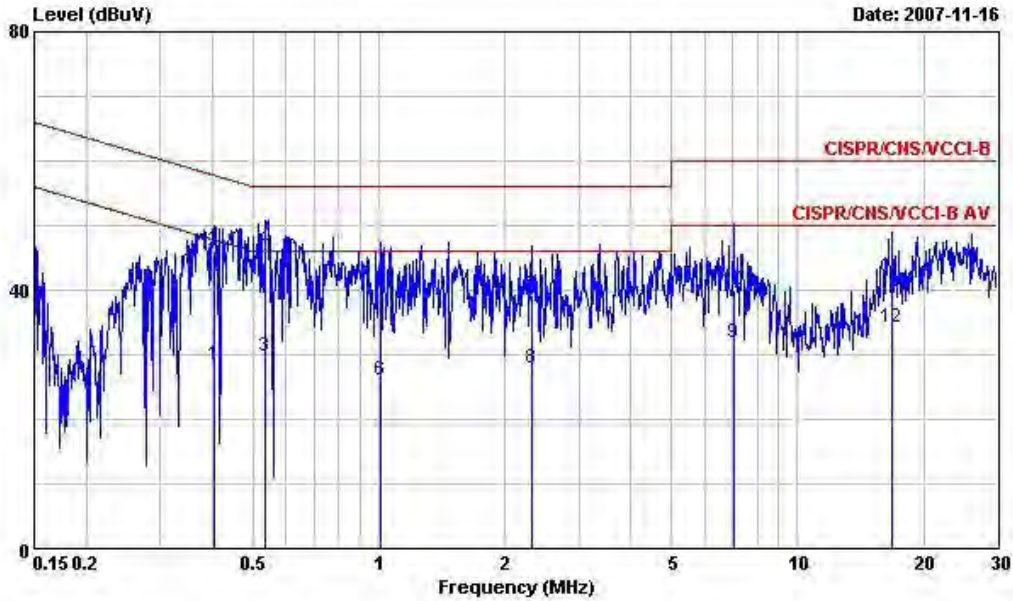

Site : C004-HY
 Condition : CISPR/CNS/VCCI-B LISN 200704 99041 NEUTRAL
 EUT : N/B
 POWER: 120V/60Hz
 Model : FR701819
 Memo : WLAN Link+BT Link+Adaptor

	Freq	Level	Over	Limit	Read	LISN	Cable	Remark
	MHz	dBuV	Limit	Line	Level	Factor	Loss	
			dB	dBuV	dBuV	dB	dB	
1	@0.4040020	28.40	-19.37	47.77	27.57	0.10	0.73	Average
2	@0.4040020	46.07	-11.70	57.77	45.24	0.10	0.73	QP
3	@0.5349810	29.63	-16.37	46.00	28.89	0.10	0.64	Average
4	@0.5349810	46.41	-9.59	56.00	45.67	0.10	0.64	QP
5	@ 1.010	40.07	-15.93	56.00	39.53	0.10	0.44	QP
6	@ 1.010	26.15	-19.85	46.00	25.61	0.10	0.44	Average
7	@ 2.310	39.29	-16.71	56.00	38.76	0.12	0.41	QP
8	@ 2.310	28.02	-17.98	46.00	27.49	0.12	0.41	Average
9	@ 7.020	31.84	-18.16	50.00	31.32	0.26	0.26	Average
10	@ 7.020	40.10	-19.90	60.00	39.58	0.26	0.26	QP
11	@ 16.840	41.99	-18.01	60.00	41.59	0.30	0.10	QP
12	@ 16.840	34.32	-15.68	50.00	33.92	0.30	0.10	Average



5.6 Test of Radiated Emission

As described in chapter 6 of this test report.

5.6.1 Test Procedures

- a. The EUT was placed on a rotatable table top 0.8 meter above ground.
- b. The EUT was set 3 meters from the interference receiving antenna which was mounted on the top of a variable height antenna tower.
- c. The table was rotated 360 degrees to determine the position of the highest radiation.
- d. The antenna is a broadband antenna and its height is varied between one meter and four meters above ground to find the maximum value of the field strength for both horizontal polarization and vertical polarization of the antenna.
- e. For each suspected emission, the EUT was arranged to its worst case and then tune the antenna tower (from 1 m to 4 m) and turntable (from 0 degree to 360 degrees) to find the maximum reading.
- f. Set the test-receiver system to Peak or CISPR quasi-peak Detect Function and specified bandwidth with Maximum Hold Mode.
- g. For testing below 1GHz, If the emission level of the EUT in peak mode was 3 dB lower than the limit specified, then testing will be stopped and peak values of EUT will be reported, otherwise, the emissions will be repeated one by one using the quasi-peak method and reported.
- h. For testing above 1GHz, the emission level of the EUT in peak mode was 20dB lower than average limit (that means the emission level in average mode also complies with the limit in average mode), then testing will be stopped and peak values of EUT will be reported, otherwise, the emissions will be measured in average mode again and reported.

5.6.2 Typical Test Setup Layout of Radiated Emission

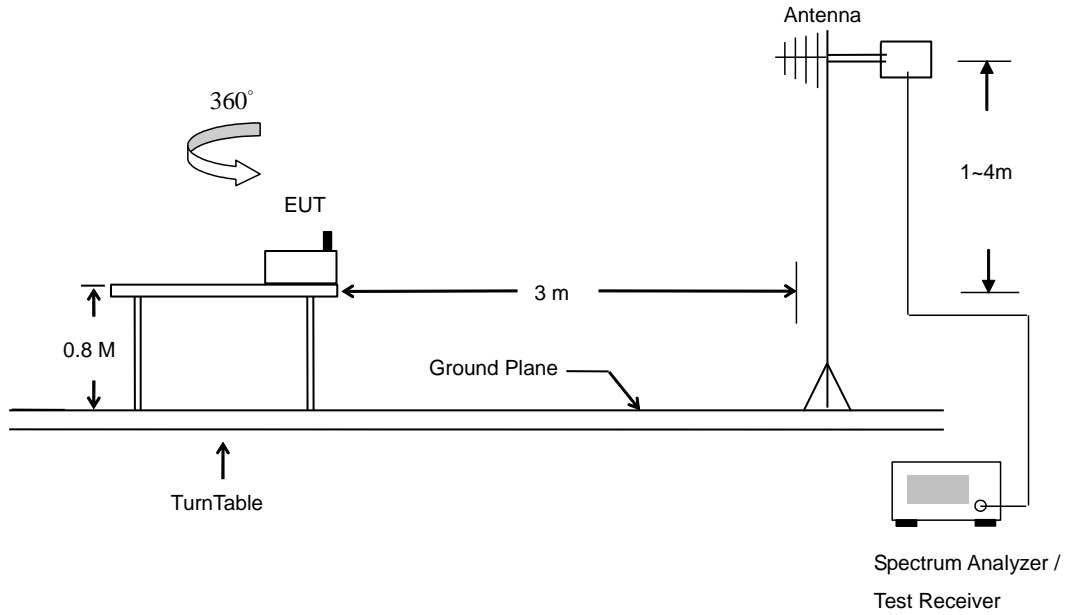



5.6.3 Test Data

- Test Mode : Mode 1
 - Temperature : 25~26°C
 - Relative Humidity : 49~51%
 - Test Engineer : Drek
 - Polarization : Horizontal

■ The test that passed at minimum margin was marked by the boldface in the following table.

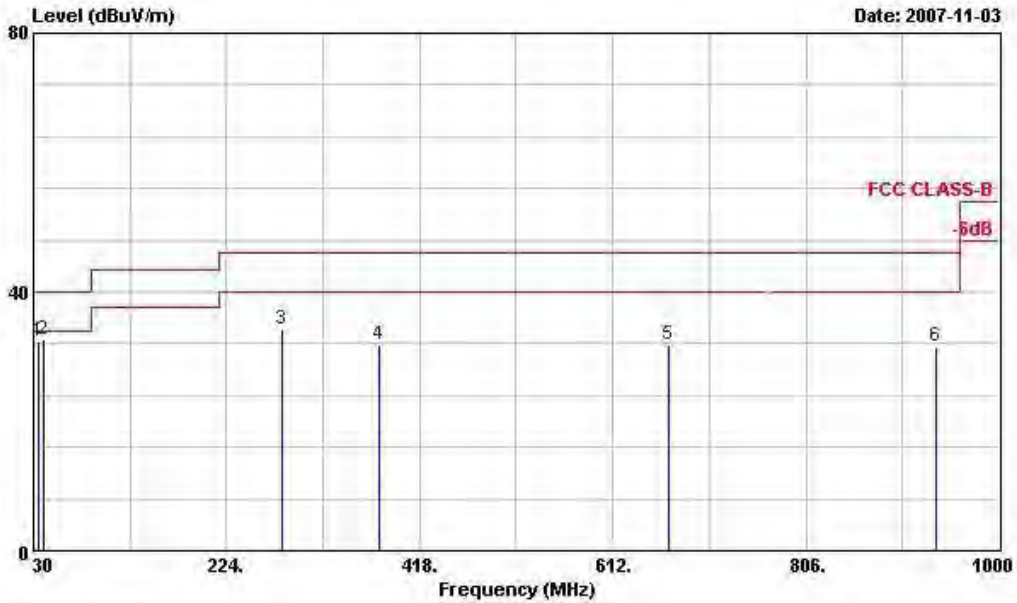

Site : 03CH04-HY
 Condition: FCC CLASS-B 3m ANT2724 HORIZONTAL
 EUT : N/B
 POWER : 120Vac/60Hz
 MODEL : FR 701819
 MEMO : 802.11a TX_CH36;5180MHz
 Data Rate: 9

	Freq	Level	Over Limit	Limit Line	ReadAntenna Level	Antenna Factor	Cable Loss	Preamp Factor	Ant Pos	Table Pos	Remark
	MHz	dBuV/m	dB	dBuV/m	dBuV	dB/m	dB	dB	cm	deg	
1	35.130	32.43	-7.57	40.00	41.88	16.29	0.91	26.65	---	---	Peak
2	39.450	32.67	-7.33	40.00	46.53	11.82	0.96	26.64	100	117	Peak
3	280.290	34.15	-11.85	46.00	45.37	12.41	2.17	25.80	---	---	Peak
4	377.000	31.80	-14.20	46.00	40.57	14.98	2.49	26.25	---	---	Peak
5	668.200	31.93	-14.07	46.00	35.44	20.06	3.45	27.02	---	---	Peak
6	937.000	31.69	-14.31	46.00	29.85	24.45	3.98	26.58	---	---	Peak

Remark: Frequency from 9KHz to 30MHz, the emission emitted by the EUT is too low to be measured.

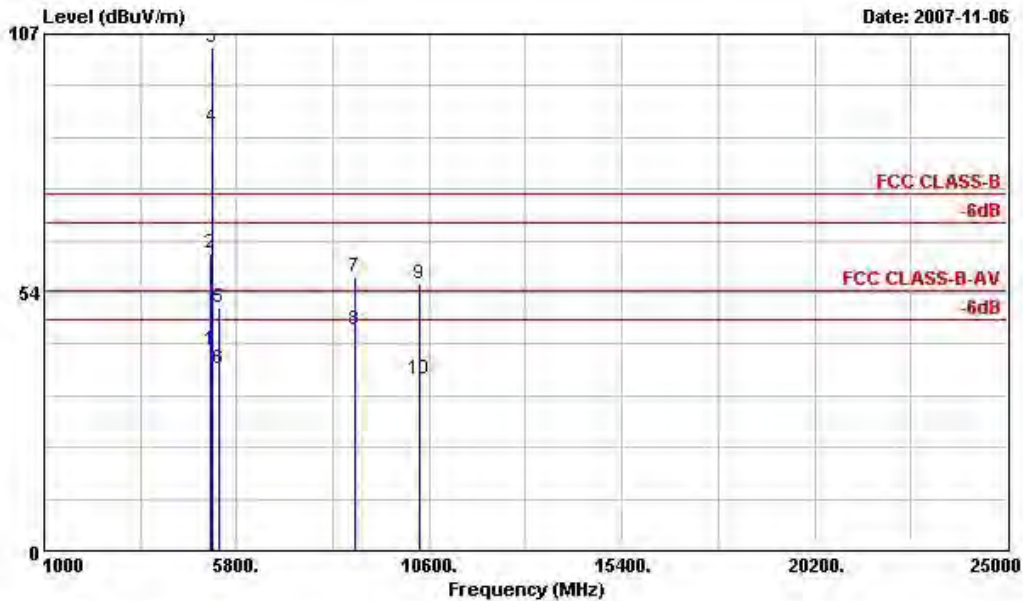

Site : 03CH04-HY
 Condition: FCC CLASS-B 3m HF-ANT-6903 HORIZONTAL
 EUT : N/B
 POWER : 120Wac/60Hz
 MODEL : FR 701819
 MEMO : 802.11a TX_CH36;5180MHz
 Data Rate: 9

	Freq	Level	Over Limit	Limit Line	ReadAntenna Level	Antenna Factor	Cable Loss	Preamp Factor	Ant Pos	Table Pos	Remark
	MHz	dBuV/m	dB	dBuV/m	dBuV	dB/m	dB	dB	cm	deg	
1	5150.000	41.67	-12.33	54.00	36.53	33.38	6.00	34.24	100	350	Average
2	5150.000	61.60	-12.40	74.00	56.46	33.38	6.00	34.24	100	0	Peak
3 X	5180.000	104.09			98.90	33.42	6.00	34.23	100	0	Peak
4 @	5180.000	87.65			82.46	33.42	6.00	34.23	100	350	Average
5	5350.000	50.36	-23.64	74.00	44.89	33.62	6.00	34.15	100	0	Peak
6	5350.000	37.63	-16.37	54.00	32.16	33.62	6.00	34.15	100	350	Average
7	8758.000	56.54	-17.46	74.00	46.19	37.80	7.15	34.60	100	0	Peak
8	8758.000	45.71	-8.29	54.00	35.36	37.80	7.15	34.60	100	138	Average
9	10362.000	55.30	-18.70	74.00	90.88	-8.72	7.80	34.65	100	0	Peak
10	10362.000	35.46	-18.54	54.00	71.04	-8.72	7.80	34.65	100	4	Average

Remark: #3 and #4 Fundamental Signal

Remark: Frequency from 25GHz to 40GHz, the emission emitted by the EUT is too low to be measured.



• Polarization : Vertical

■ The test that passed at minimum margin was marked by the boldface in the following table.

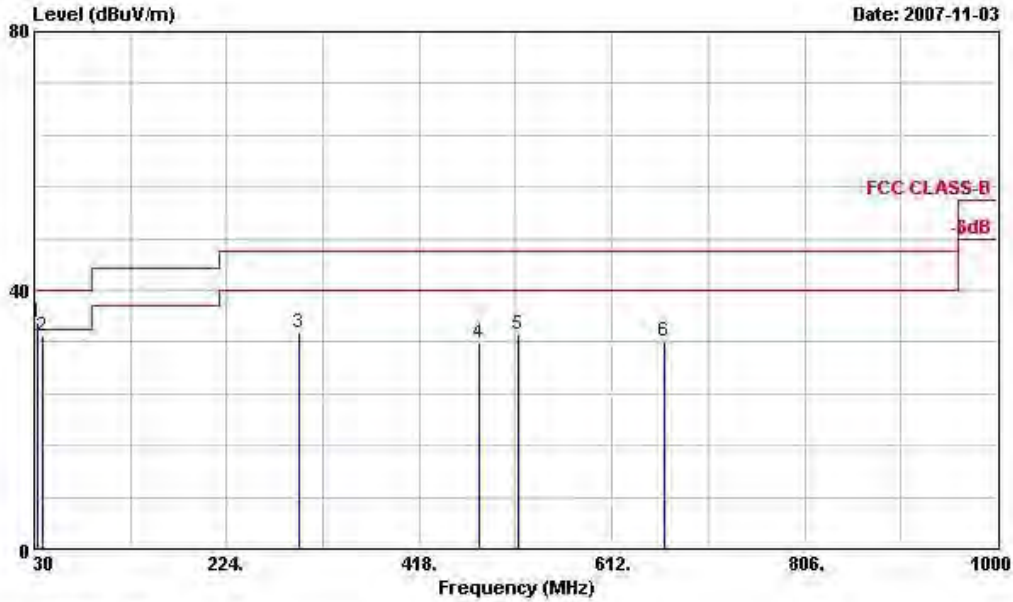

Site : 03CH04-HY
 Condition: FCC CLASS-B 3m ANT2724 VERTICAL
 EUT : N/B
 POWER : 120Vac/60Hz
 MODEL : FR 701819
 MEMO : 802.11a TX_CH36;5180MHz
 Data Rate: 9

	Freq	Level	Over	Limit	Read	Antenna	Cable	Preamp	Ant	Table	
	MHz	dBuV/m	Limit	Line	Level	Factor	Loss	Factor	Pos	Pos	Remark
			dB	dBuV/m	dBuV	dB/m	dB	dB	cm	deg	
1	32.700	35.05	-4.95	40.00	44.49	16.33	0.90	26.66	100	175	Peak
2	38.370	32.95	-7.05	40.00	45.93	12.71	0.95	26.64	---	---	Peak
3	296.220	33.35	-12.65	46.00	44.53	12.33	2.23	25.74	---	---	Peak
4	478.500	31.78	-14.22	46.00	39.29	16.65	2.77	26.94	---	---	Peak
5	517.700	33.03	-12.97	46.00	39.79	17.43	2.88	27.07	---	---	Peak
6	665.400	32.02	-13.98	46.00	35.54	20.06	3.45	27.02	---	---	Peak

Remark: Frequency from 9KHz to 30MHz, the emission emitted by the EUT is too low to be measured.

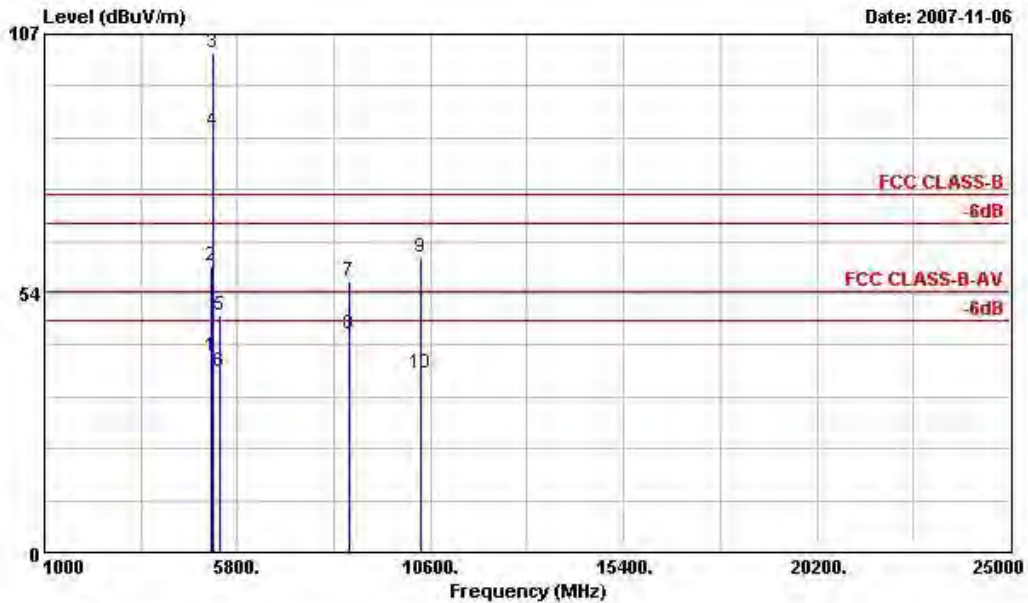

Site : 03CH04-HY
 Condition: FCC CLASS-B 3m HF-ANT-6903 VERTICAL
 EUT : N/B
 POWER : 120Vac/60Hz
 MODEL : FR 701819
 MEMO : 802.11a TX_CH36;5180MHz
 Data Rate: 9

	Freq	Level	Over	Limit	ReadAntenna	Cable	Preamp	Ant	Table	
	MHz	dBuV/m	dB	dBuV/m	dBuV	Loss	Factor	Pos	Pos	Remark
					dB/m	dB	dB	cm	deg	
1	5150.000	40.49	-13.51	54.00	35.35	33.38	6.00	34.24	102	4 Average
2	5150.000	59.27	-14.73	74.00	54.13	33.38	6.00	34.24	100	0 Peak
3 X	5180.000	103.02			97.83	33.42	6.00	34.23	100	0 Peak
4 @	5180.000	87.05			81.86	33.42	6.00	34.23	102	4 Average
5	5350.000	49.06	-24.94	74.00	43.59	33.62	6.00	34.15	100	0 Peak
6	5350.000	37.37	-16.63	54.00	31.90	33.62	6.00	34.15	102	4 Average
7	8566.000	55.99	-18.01	74.00	45.82	37.58	7.05	34.46	100	0 Peak
8	8566.000	45.10	-8.90	54.00	34.93	37.58	7.05	34.46	100	147 Average
9	10365.000	60.80	-13.20	74.00	96.38	-8.72	7.80	34.65	100	0 Peak
10	10365.000	36.92	-17.08	54.00	72.50	-8.72	7.80	34.65	100	201 Average

Remark: #3 and #4 Fundamental Signal

Remark: Frequency from 25GHz to 40GHz, the emission emitted by the EUT is too low to be measured.



- Test Mode : Mode 2
- Polarization : Horizontal

■ The test that passed at minimum margin was marked by the boldface in the following table.

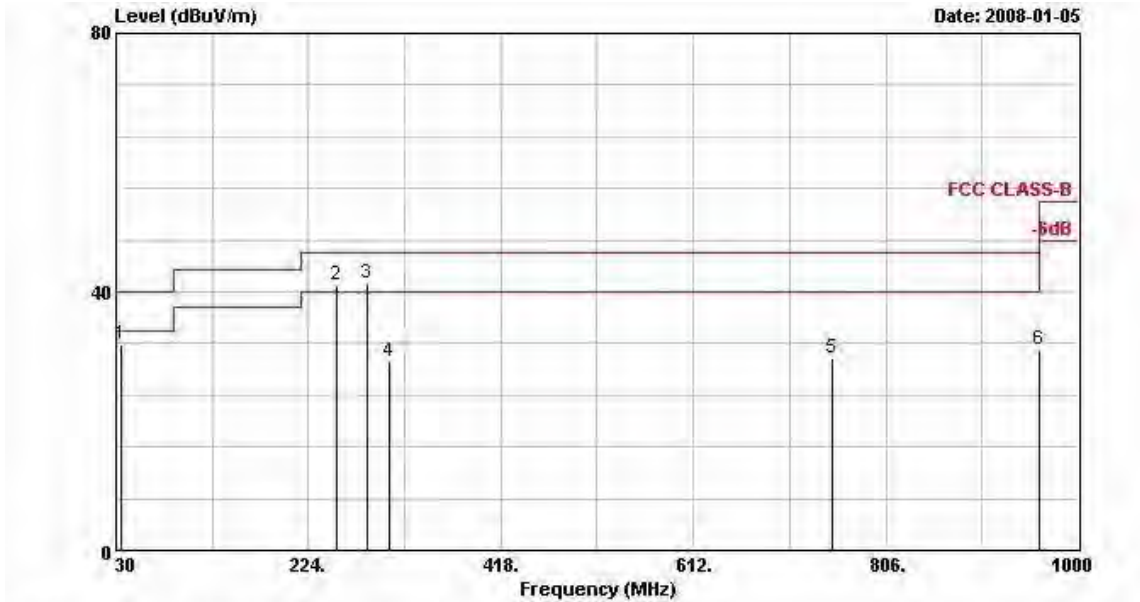

Site : 03CH04-HY
 Condition: FCC CLASS-B 3m ANT2724 HORIZONTAL
 EUT : N/B
 POWER : 120Vac/60Hz
 MODEL : FR 701819
 MEMO : 802.11a TX_CH44;5220MHz
 Data Rate: 24

	Freq	Level	Over Limit	Limit Line	ReadAntenna Level	Antenna Factor	Cable Loss	Preamp Factor	Ant Pos	Table Pos	Remark
	MHz	dBuV/m	dB	dBuV/m	dBuV	dB/m	dB	dB	cm	deg	
1	35.130	31.86	-8.14	40.00	42.92	16.29	0.91	28.26	---	---	Peak
2	251.940	41.04	-4.96	46.00	54.12	12.56	2.06	27.70	---	---	Peak
3	283.260	41.32	-4.68	46.00	54.38	12.40	2.18	27.63	100	125	Peak
4	304.900	29.23	-16.77	46.00	42.13	12.48	2.26	27.63	---	---	Peak
5	752.200	29.74	-16.26	46.00	35.19	19.99	3.56	29.00	---	---	Peak
6	960.100	30.95	-23.05	54.00	30.61	25.04	3.99	28.68	---	---	Peak

Remark: Frequency from 9KHz to 30MHz, the emission emitted by the EUT is too low to be measured.

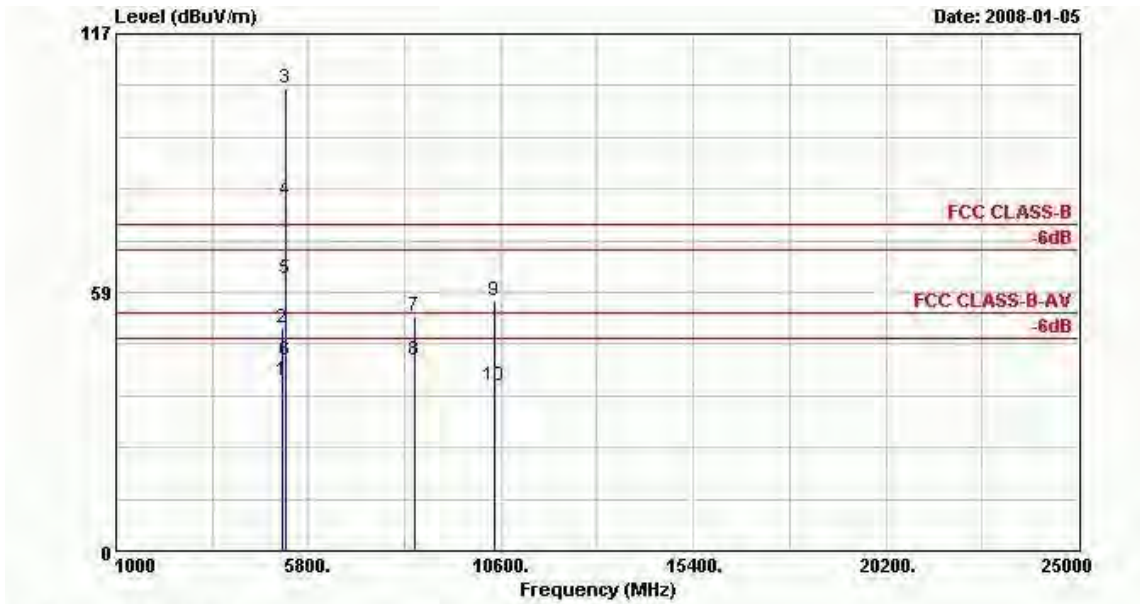

Site : 03CH04-HY
 Condition: FCC CLASS-B 3m HF-ANT-3117 HORIZONTAL
 EUT : N/B
 POWER : 120Vac/60Hz
 MODEL : FR 701819
 MEMO : 802.11a TX_CH44:5220MHz
 Data Rate: 24

	Freq	Level	Over	Limit	ReadAntenna	Cable	Preamp	Ant	Table	
	MHz	dBuV/m	dB	dBuV/m	Level	Loss	Factor	Pos	Pos	Remark
					dBuV	Factor	dB	cm	deg	
1	5150.000	38.31	-15.69	54.00	31.66	34.89	6.00	34.24	100	44 Average
2	5150.000	50.45	-23.55	74.00	43.80	34.89	6.00	34.24	100	0 Peak
3 @	5220.000	104.71			98.00	34.93	6.00	34.22	100	0 Peak
4 X	5220.000	79.28			72.57	34.93	6.00	34.22	100	44 Average
5	5250.000	61.65	-12.35	74.00	54.89	34.95	6.00	34.19	100	0 Peak
6	5250.000	42.96	-11.04	54.00	36.20	34.95	6.00	34.19	100	44 Average
7	8430.000	53.25	-20.75	74.00	44.25	36.29	6.98	34.27	100	0 Peak
8	8430.000	43.23	-10.77	54.00	34.23	36.29	6.98	34.27	100	120 Average
9	10434.000	56.61	-17.39	74.00	92.00	-8.61	7.80	34.58	100	0 Peak
10	10434.000	37.50	-16.50	54.00	72.89	-8.61	7.80	34.58	100	115 Average

Remark: #3 and #4 Fundamental Signal

Remark: Frequency from 25GHz to 40GHz, the emission emitted by the EUT is too low to be measured.



• Polarization : Vertical

■ The test that passed at minimum margin was marked by the boldface in the following table.

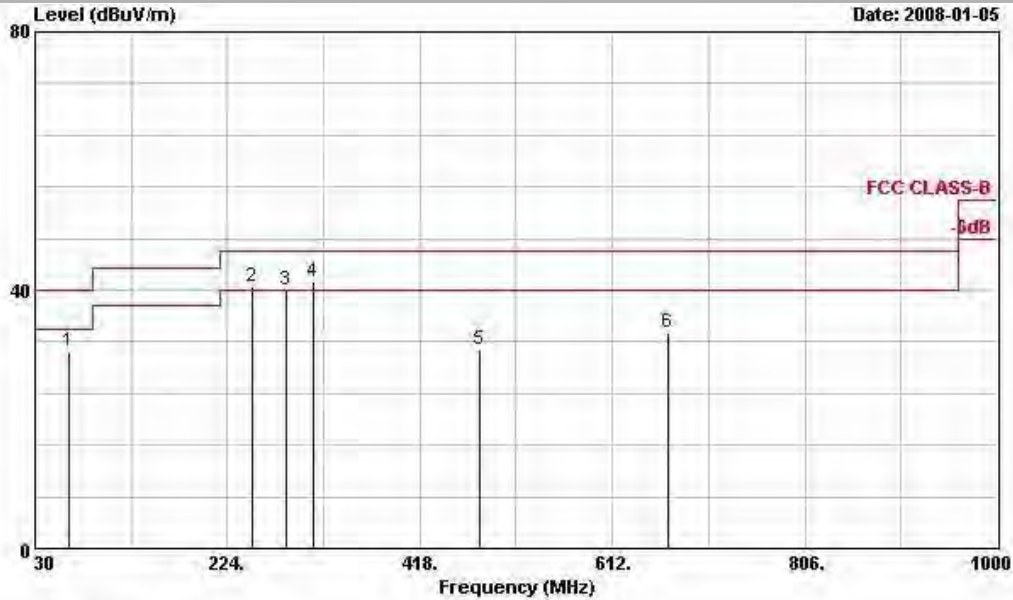

Site : 03CH04-HY
 Condition: FCC CLASS-B 3m ANT2724 VERTICAL
 EUT : N/B
 POWER : 120Vac/60Hz
 MODEL : FR 701819
 MEMO : 802.11a TX_CH44;5220MHz
 Data Rate:24

	Freq	Level	Over	Limit	Read	Antenna	Cable	Preamp	Ant	Table	
	MHz	dBuV/m	dB	dBuV/m	Level	Factor	Loss	Factor	Pos	Pos	Remark
					dBuV	dB/m	dB	dB	cm	deg	
1	64.020	30.46	-9.54	40.00	53.30	4.29	1.14	28.27	---	---	Peak
2	248.970	40.43	-5.57	46.00	53.59	12.50	2.05	27.70	---	---	Peak
3	282.450	39.90	-6.10	46.00	52.96	12.40	2.17	27.64	---	---	Peak
4	309.800	41.26	-4.74	46.00	54.01	12.64	2.27	27.67	100	187	Peak
5	478.500	30.82	-15.18	46.00	40.24	16.65	2.77	28.85	---	---	Peak
6	668.200	33.41	-12.59	46.00	39.00	20.06	3.45	29.10	---	---	Peak

Remark: Frequency from 9KHz to 30MHz, the emission emitted by the EUT is too low to be measured.

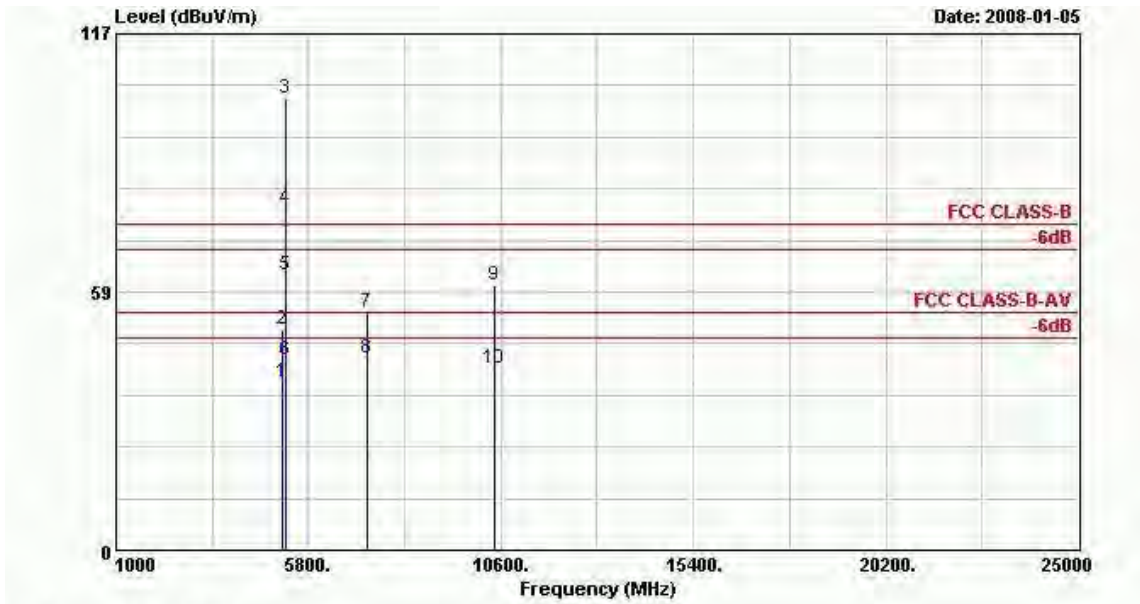

Site : 03CH04-HY
 Condition: FCC CLASS-B 3m HF-ANT-3117 VERTICAL
 EUT : N/B
 POWER : 120Vac/60Hz
 MODEL : FR 701819
 MEMO : 802.11a TX_CH44:5220MHz
 Data Rate: 24

	Freq	Level	Over	Limit	ReadAntenna	Cable	Preamp	Ant	Table	
	MHz	dBuV/m	dB	dBuV/m	dBuV	Loss	Factor	Pos	Pos	Remark
					dB/m	dB	dB	cm	deg	
1	5150.000	38.14	-15.86	54.00	31.49	34.89	6.00	34.24	100	62 Average
2	5150.000	50.16	-23.84	74.00	43.51	34.89	6.00	34.24	100	0 Peak
3 @	5220.000	102.49			95.78	34.93	6.00	34.22	100	0 Peak
4 X	5220.000	77.33			70.62	34.93	6.00	34.22	100	62 Average
5	5250.000	62.16	-11.84	74.00	55.40	34.95	6.00	34.19	100	0 Peak
6	5250.000	43.18	-10.82	54.00	36.42	34.95	6.00	34.19	100	62 Average
7	7260.000	53.89	-20.11	74.00	44.58	36.00	6.46	33.15	100	0 Peak
8	7260.000	43.57	-10.43	54.00	34.26	36.00	6.46	33.15	100	174 Average
9	10446.000	60.20	-13.80	74.00	95.56	-8.58	7.80	34.58	100	0 Peak
10	10446.000	41.30	-12.70	54.00	76.66	-8.58	7.80	34.58	100	11 Average

Remark: #3 and #4 Fundamental Signal

Remark: Frequency from 25GHz to 40GHz, the emission emitted by the EUT is too low to be measured.



- Test Mode : Mode 3
- Polarization : Horizontal

The test that passed at minimum margin was marked by the boldface in the following table.

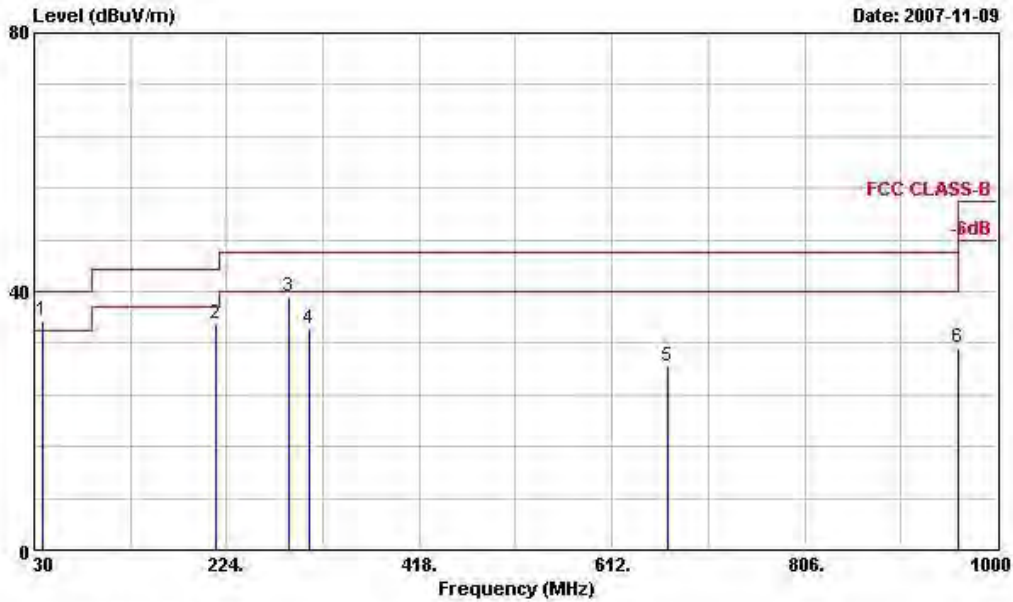

Site : 03CH04-HY
 Condition: FCC CLASS-B 3m ANT2724 HORIZONTAL
 EUT : N/B
 POWER : 120Vac/60Hz
 MODEL : FR 701819
 MEMO : 802.11a TX_CH48;5240MHz
 Data Rate: 9

	Freq	Level	Over Limit	Limit Line	ReadAntenna Level	Antenna Factor	Cable Loss	Preamp Factor	Ant Pos	Table Pos	Remark
	MHz	dBuV/m	dB	dBuV/m	dBuV	dB/m	dB	dB	cm	deg	
1 @	38.100	35.50	-4.50	40.00	49.21	13.61	0.95	28.27	100	187	Peak
2	213.330	34.93	-8.57	43.50	51.02	9.76	1.93	27.77	---	---	Peak
3	286.770	39.22	-6.78	46.00	52.28	12.38	2.19	27.63	---	---	Peak
4	307.700	34.15	-11.85	46.00	46.96	12.58	2.27	27.66	---	---	Peak
5	668.200	28.54	-17.46	46.00	34.13	20.06	3.45	29.10	---	---	Peak
6	960.100	31.24	-22.76	54.00	30.90	25.04	3.99	28.68	---	---	Peak

Remark: Frequency from 9KHz to 30MHz, the emission emitted by the EUT is too low to be measured.

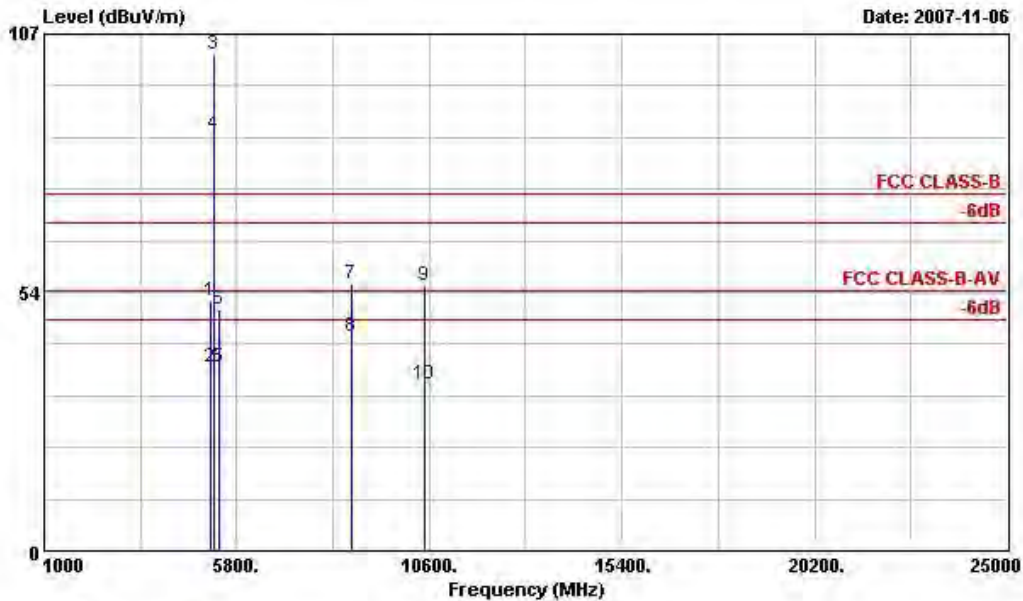

Site : 03CH04-HY
 Condition: FCC CLASS-B 3m HF-ANT-6903 HORIZONTAL
 EUT : N/B
 POWER : 120Wac/60Hz
 MODEL : FR 701819
 MEMO : 802.11a TX_CH48;5240MHz
 Data Rate: 9

	Freq	Level	Over Limit	Limit Line	ReadAntenna Level	Antenna Factor	Cable Loss	Preamp Factor	Ant Pos	Table Pos	Remark
	MHz	dBuV/m	dB	dBuV/m	dBuV	dB/m	dB	dB	cm	deg	
1	5150.000	51.80	-22.20	74.00	46.66	33.38	6.00	34.24	100	0	Peak
2	5150.000	38.12	-15.88	54.00	32.98	33.38	6.00	34.24	119	6	Average
3 @	5240.000	102.81			97.54	33.48	6.00	34.21	100	0	Peak
4 @	5240.000	86.14			80.87	33.48	6.00	34.21	119	6	Average
5	5350.000	37.92	-16.08	54.00	32.45	33.62	6.00	34.15	119	6	Average
6	5350.000	50.05	-23.95	74.00	44.58	33.62	6.00	34.15	100	0	Peak
7	8678.000	55.36	-18.64	74.00	45.07	37.72	7.11	34.54	100	0	Peak
8	8678.000	44.45	-9.55	54.00	34.16	37.72	7.11	34.54	100	134	Average
9	10482.000	54.86	-19.14	74.00	90.12	-8.53	7.80	34.53	100	0	Peak
10	10482.000	34.58	-19.42	54.00	69.84	-8.53	7.80	34.53	100	6	Average

Remark: #3 and #4 Fundamental Signal

Remark: Frequency from 25GHz to 40GHz, the emission emitted by the EUT is too low to be measured.



• Polarization : Vertical

■ The test that passed at minimum margin was marked by the boldface in the following table.

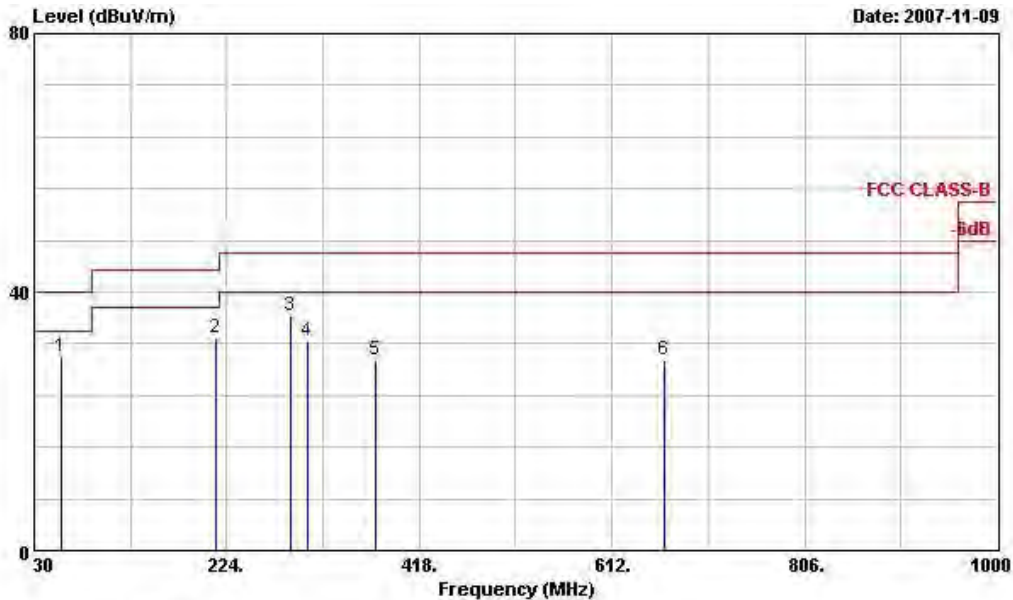

Site : 03CH04-HY
 Condition: FCC CLASS-B 3m ANT2724 VERTICAL
 EUT : N/B
 POWER : 120Vac/60Hz
 MODEL : FR 701819
 MEMO : 802.11a TX_CH48;5240MHz
 Data Rate:9

	Freq	Level	Over Limit	Limit Line	ReadAntenna Level	Antenna Factor	Cable Loss	Preamp Factor	Ant Pos	Table Pos	Remark
	MHz	dBuV/m	dB	dBuV/m	dBuV	dB/m	dB	dB	cm	deg	
1	57.540	30.12	-9.88	40.00	52.83	4.49	1.09	28.28	---	---	Peak
2	213.060	32.97	-10.53	43.50	49.06	9.76	1.92	27.77	---	---	Peak
3	287.850	36.22	-9.78	46.00	49.28	12.37	2.19	27.62	100	287	Peak
4	304.900	32.32	-13.68	46.00	45.22	12.48	2.26	27.63	---	---	Peak
5	374.200	29.54	-16.46	46.00	40.29	14.88	2.49	28.12	---	---	Peak
6	665.400	29.44	-16.56	46.00	35.04	20.06	3.48	29.10	---	---	Peak

Remark: Frequency from 9KHz to 30MHz, the emission emitted by the EUT is too low to be measured.

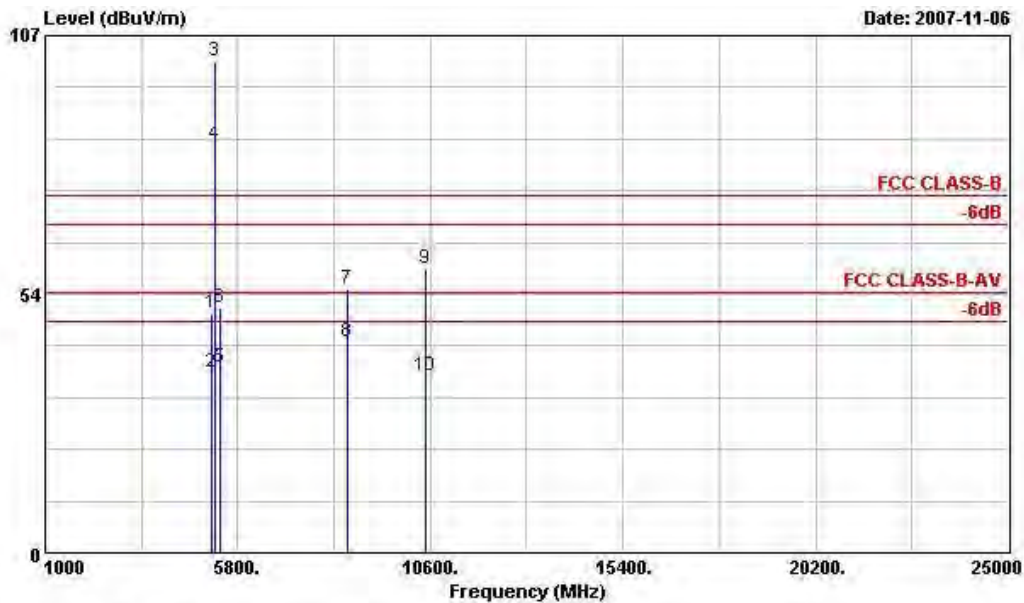

Site : 03CH04-HY
 Condition: FCC CLASS-B 3m HF-ANT-6903 VERTICAL
 EUT : N/B
 POWER : 120Vac/60Hz
 MODEL : FR 701819
 MEMO : 802.11a TX_CH48;5240MHz
 Data Rate: 9

	Freq	Level	Over	Limit	ReadAntenna	Cable	Preamp	Ant	Table	
	MHz	dBuV/m	dB	dBuV/m	dBuV	Loss	Factor	Pos	Pos	Remark
					dB/m	dB	dB	cm	deg	
1	5150.000	49.72	-24.28	74.00	44.58	33.38	6.00	34.24	100	0 Peak
2	5150.000	37.34	-16.66	54.00	32.20	33.38	6.00	34.24	100	3 Average
3 @	5240.000	101.61			96.34	33.48	6.00	34.21	100	0 Peak
4 @	5240.000	84.44			79.17	33.48	6.00	34.21	100	3 Average
5	5350.000	38.25	-15.75	54.00	32.78	33.62	6.00	34.15	100	3 Average
6	5350.000	50.74	-23.26	74.00	45.27	33.62	6.00	34.15	100	0 Peak
7	8550.000	54.61	-19.39	74.00	44.44	37.56	7.05	34.44	100	0 Peak
8	8550.000	43.51	-10.49	54.00	33.34	37.56	7.05	34.44	100	45 Average
9	10478.000	58.83	-15.17	74.00	94.09	-8.53	7.80	34.53	100	0 Peak
10	10478.000	36.45	-17.55	54.00	71.71	-8.53	7.80	34.53	100	6 Average

Remark: #3 and #4 Fundamental Signal

Remark: Frequency from 25GHz to 40GHz, the emission emitted by the EUT is too low to be measured.



- Test Mode : Mode 4
- Polarization : Horizontal

The test that passed at minimum margin was marked by the boldface in the following table.

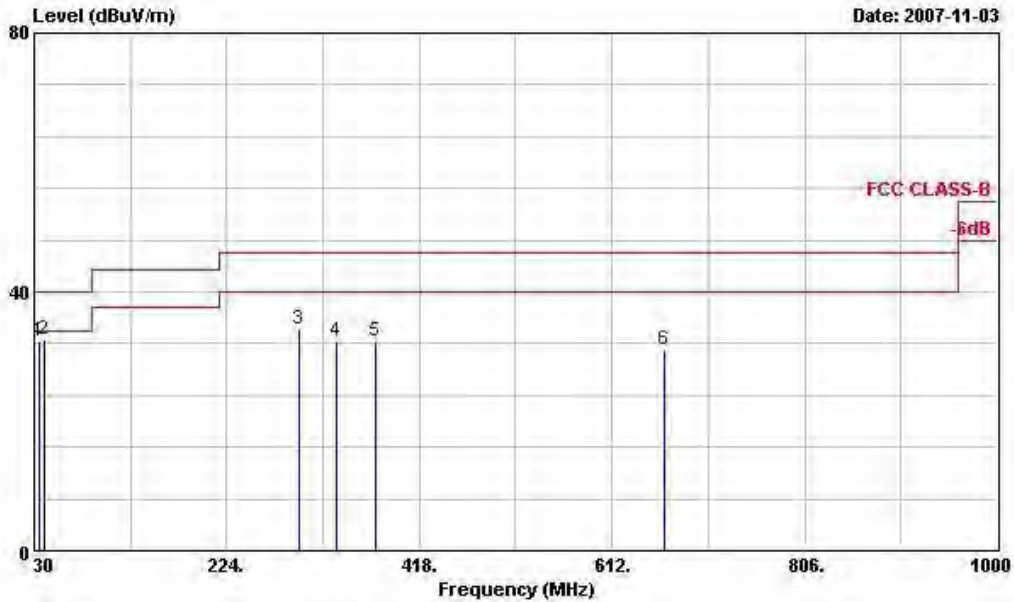

Site : 03CH04-HY
 Condition: FCC CLASS-B 3m ANT2724 HORIZONTAL
 EUT : N/B
 POWER : 120Vac/60Hz
 MODEL : FR 701819
 MEMO : 802.11a TX_CH52;5260MHz
 Data Rate: 9

	Freq	Level	Over Limit	Limit Line	ReadAntenna Level	Antenna Factor	Cable Loss	Preamp Factor	Ant Pos	Table Pos	Remark
	MHz	dBuV/m	dB	dBuV/m	dBuV	dB/m	dB	dB	cm	deg	
1	35.130	32.34	-7.66	40.00	41.79	16.29	0.91	26.65	---	---	Peak
2	39.450	32.65	-7.35	40.00	46.51	11.82	0.96	26.64	100	196	Peak
3	296.220	34.16	-11.84	46.00	45.34	12.33	2.23	25.74	---	---	Peak
4	335.000	32.27	-13.73	46.00	42.37	13.51	2.35	25.97	---	---	Peak
5	374.200	32.49	-13.51	46.00	41.36	14.88	2.49	26.24	---	---	Peak
6	665.400	31.15	-14.85	46.00	34.67	20.06	3.45	27.02	---	---	Peak

Remark: Frequency from 9KHz to 30MHz, the emission emitted by the EUT is too low to be measured.

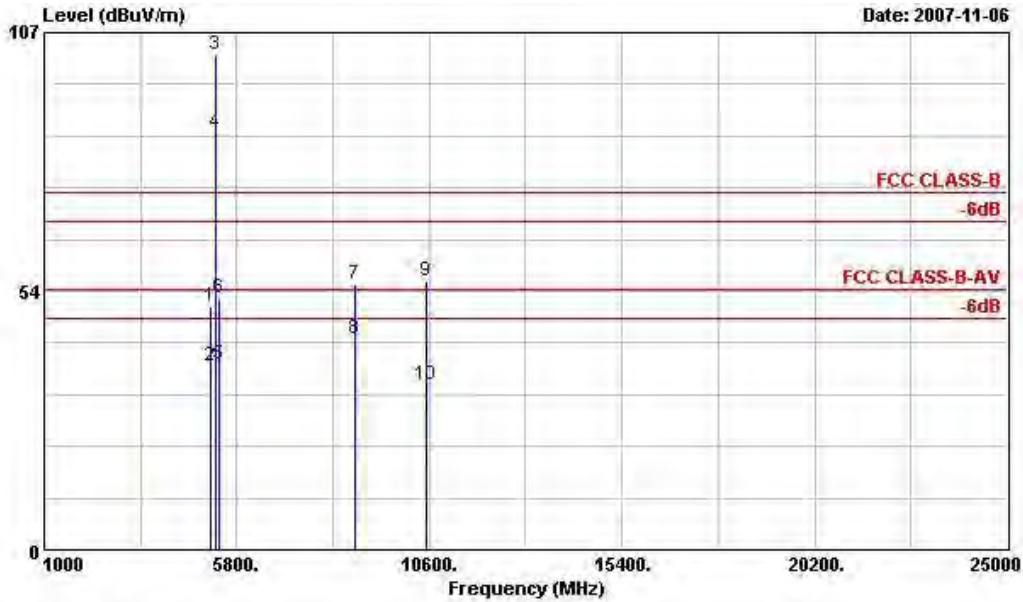

Site : 03CH04-HY
 Condition: FCC CLASS-B 3m HF-ANT-6903 HORIZONTAL
 EUT : N/B
 POWER : 120Vac/60Hz
 MODEL : FR 701819
 MEMO : 802.11a TX_CH52;5260MHz
 Data Rate:9

	Freq	Level	Over	Limit	ReadAntenna	Cable	Preamp	Ant	Table	
	MHz	dBuV/m	dB	dBuV/m	dBuV	Loss	Factor	Pos	Pos	Remark
					dB/m	dB	dB	cm	deg	
1	5150.000	50.29	-23.71	74.00	45.15	33.38	6.00	34.24	100	0 Peak
2	5150.000	37.93	-16.07	54.00	32.79	33.38	6.00	34.24	114	255 Average
3 X	5260.000	102.28			96.95	33.52	6.00	34.19	100	0 Peak
4 @	5260.000	86.18			80.85	33.52	6.00	34.19	114	255 Average
5	5350.000	38.48	-15.52	54.00	33.01	33.62	6.00	34.15	114	255 Average
6	5350.000	52.06	-21.94	74.00	46.59	33.62	6.00	34.15	100	0 Peak
7	8732.000	54.88	-19.12	74.00	44.55	37.78	7.13	34.58	100	0 Peak
8	8732.000	43.80	-10.20	54.00	33.47	37.78	7.13	34.58	100	187 Average
9	10522.000	55.75	-18.25	74.00	90.94	-8.49	7.80	34.50	100	0 Peak
10	10522.000	34.13	-19.87	54.00	69.32	-8.49	7.80	34.50	100	22 Average

Remark: #3 and #4 Fundamental Signal

Remark: Frequency from 25GHz to 40GHz, the emission emitted by the EUT is too low to be measured.



• Polarization : Vertical

■ The test that passed at minimum margin was marked by the boldface in the following table.

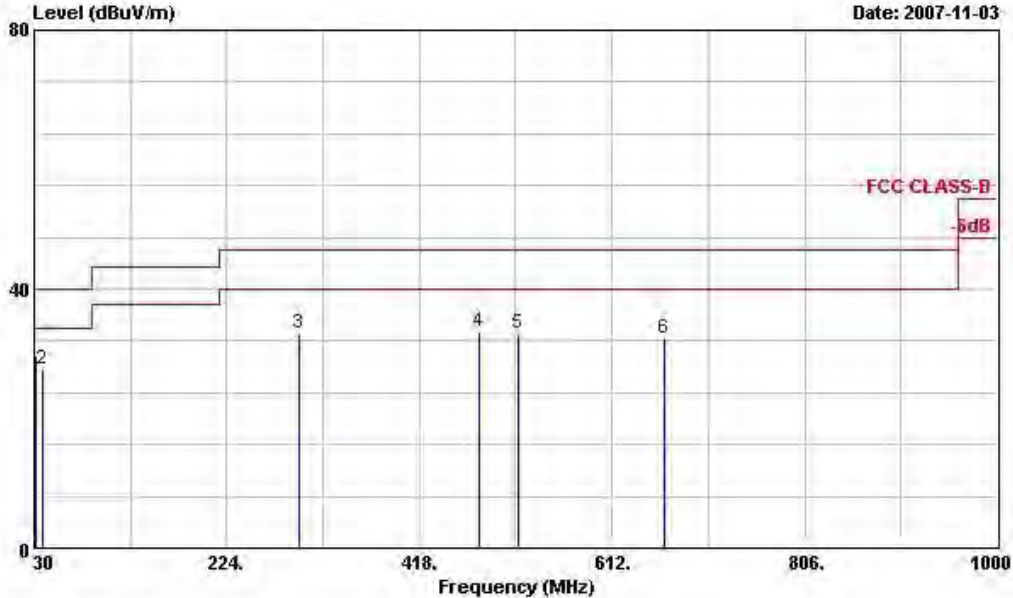

Site : 03CH04-HY
 Condition: FCC CLASS-B 3m ANT2724 VERTICAL
 EUT : N/B
 POWER : 120Vac/60Hz
 MODEL : FR 701819
 MEMO : 802.11a TX_CH52;5260MHz
 Data Rate: 9

	Freq	Level	Over Limit	Limit Line	ReadAntenna Level	Antenna Factor	Cable Loss	Preamp Factor	Ant Pos	Table Pos	Remark
	MHz	dBuV/m	dB	dBuV/m	dBuV	dB/m	dB	dB	cm	deg	
1	31.890	29.75	-10.25	40.00	39.18	16.34	0.89	26.66	100	161	Peak
2	38.370	27.51	-12.49	40.00	40.49	12.71	0.95	26.64	---	---	Peak
3	297.570	33.04	-12.96	46.00	44.22	12.32	2.23	25.74	---	---	Peak
4	478.500	33.49	-12.51	46.00	41.00	16.65	2.77	26.94	---	---	Peak
5	517.700	33.08	-12.92	46.00	39.84	17.43	2.88	27.07	---	---	Peak
6	665.400	32.45	-13.55	46.00	35.97	20.06	3.45	27.02	---	---	Peak

Remark: Frequency from 9KHz to 30MHz, the emission emitted by the EUT is too low to be measured.

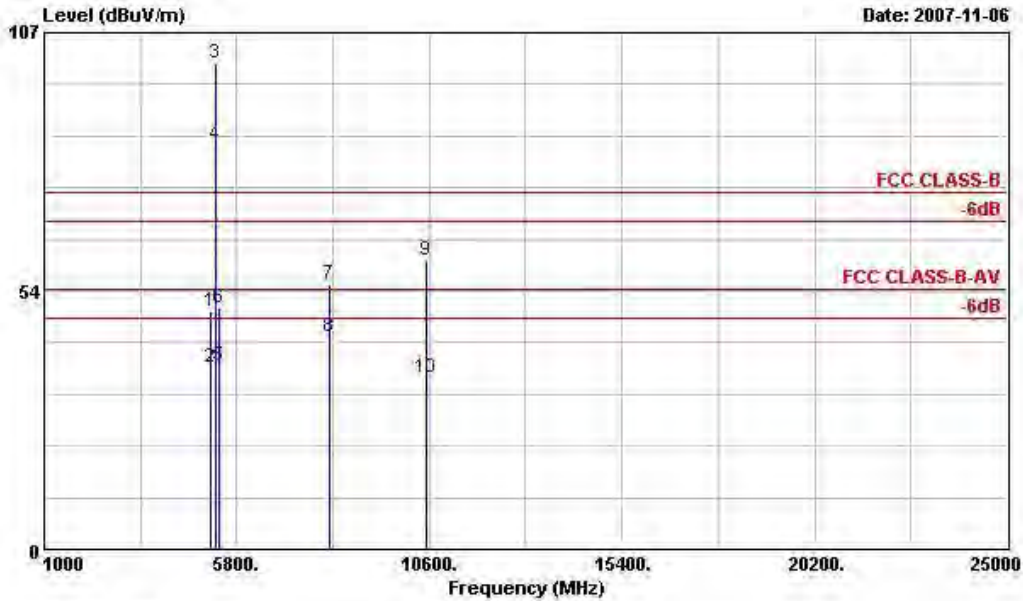

Site : 03CH04-HY
 Condition: FCC CLASS-B 3m HF-ANT-6903 VERTICAL
 EUT : N/B
 POWER : 120Vac/60Hz
 MODEL : FR 701819
 MEMO : 802.11a TX_CH52;5260MHz
 Data Rate: 9

	Freq	Level	Over	Limit	ReadAntenna	Cable	Preamp	Ant	Table	
	MHz	dBuV/m	dB	dBuV/m	dBuV	dB	dB	cm	deg	Remark
1	5150.000	49.37	-24.63	74.00	44.23	33.38	6.00	34.24	100	0 Peak
2	5150.000	37.55	-16.45	54.00	32.41	33.38	6.00	34.24	100	6 Average
3 X	5260.000	100.76			95.43	33.52	6.00	34.19	100	0 Peak
4 @	5260.000	83.74			78.41	33.52	6.00	34.19	100	6 Average
5	5350.000	37.91	-16.09	54.00	32.44	33.62	6.00	34.15	100	6 Average
6	5350.000	49.96	-24.04	74.00	44.49	33.62	6.00	34.15	100	0 Peak
7	8102.000	54.82	-19.18	74.00	44.83	36.94	6.81	33.77	100	0 Peak
8	8102.000	44.14	-9.86	54.00	34.15	36.94	6.81	33.77	100	177 Average
9	10521.000	59.77	-14.23	74.00	94.96	-8.49	7.80	34.50	100	0 Peak
10	10521.000	35.39	-18.61	54.00	70.58	-8.49	7.80	34.50	100	14 Average

Remark: #3 and #4 Fundamental Signal

Remark: Frequency from 25GHz to 40GHz, the emission emitted by the EUT is too low to be measured.



- Test Mode : Mode 5
- Polarization : Horizontal

■ The test that passed at minimum margin was marked by the boldface in the following table.

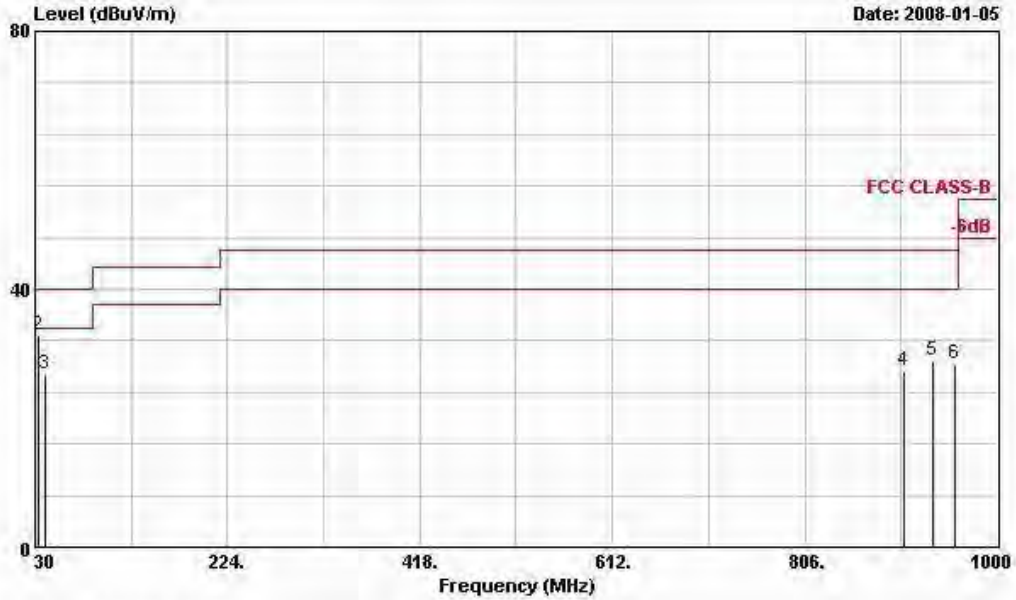

Site : 03CH04-HY
 Condition: FCC CLASS-B 3m ANT2724 HORIZONTAL
 EUT : N/B
 POWER : 120Vac/60Hz
 MODEL : FR 701819
 MEMO : 802.11a TX_CH60;5300MHZ
 Data Rate: 24

	Freq	Level	Over	Limit	Read	Antenna	Cable	Preamp	Ant	Table	
	MHz	dBuV/m	dB	dBuV/m	dBuV	dB/m	dB	dB	cm	deg	Remark
1	30.000	24.70	-15.30	40.00	35.70	16.38	0.87	28.25	---	---	Peak
2 @	32.970	32.95	-7.05	40.00	43.99	16.33	0.90	28.26	100	143	Peak
3	40.530	26.81	-13.19	40.00	42.65	11.46	0.97	28.28	---	---	Peak
4	906.200	27.47	-18.53	46.00	28.64	23.66	3.96	28.79	---	---	Peak
5	934.200	28.92	-17.08	46.00	29.30	24.37	3.97	28.73	---	---	Peak
6	956.600	28.29	-17.71	46.00	28.05	24.94	3.98	28.69	---	---	Peak

Remark: Frequency from 9KHz to 30MHz, the emission emitted by the EUT is too low to be measured.

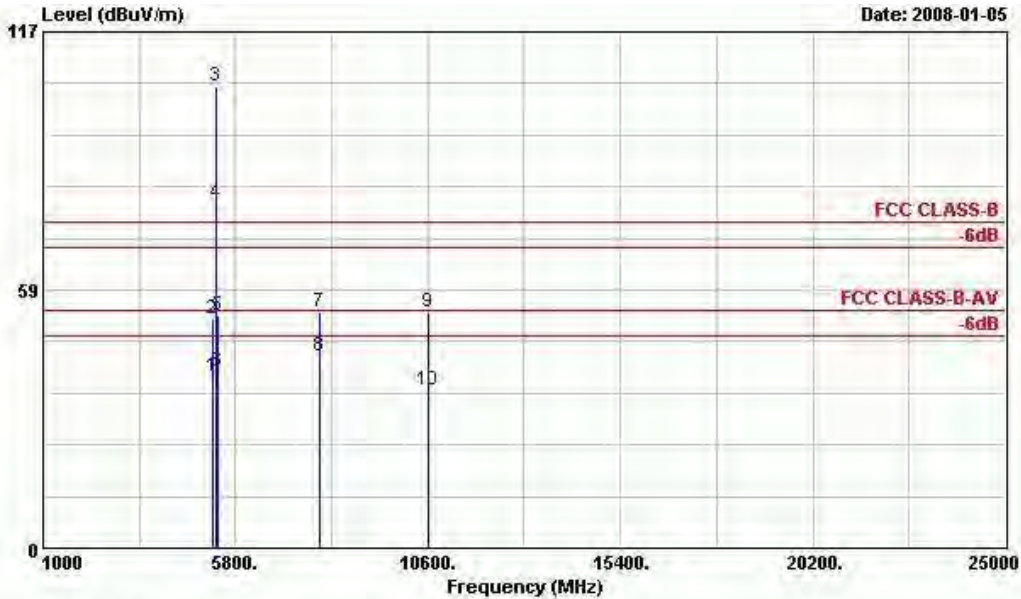

Site : 03CH04-HY
 Condition: FCC CLASS-B 3m HF-ANT-3117 HORIZONTAL
 EUT : N/B
 POWER : 120Vac/60Hz
 MODEL : FR 701819
 MEMO : 802.11a TX_CH60;5300MHz
 Data Rate: 24

	Freq	Level	Over	Limit	ReadAntenna	Cable	Preamp	Ant	Table	
	MHz	dBuV/m	dB	dBuV/m	dBuV	Loss	Factor	Pos	Pos	Remark
					dB/m	dB	dB	cm	deg	
1	5250.000	38.81	-15.19	54.00	32.05	34.95	6.00	34.19	100	51 Average
2	5250.000	52.06	-21.94	74.00	45.30	34.95	6.00	34.19	100	0 Peak
3 @	5300.000	104.57			97.76	34.98	6.00	34.17	100	0 Peak
4 @	5300.000	78.20			71.39	34.98	6.00	34.17	100	51 Average
5	5350.000	52.72	-21.28	74.00	45.86	35.01	6.00	34.15	100	0 Peak
6	5350.000	40.03	-13.97	54.00	33.17	35.01	6.00	34.15	100	51 Average
7	7886.000	53.57	-20.43	74.00	44.35	36.15	6.71	33.65	100	0 Peak
8	7886.000	43.35	-10.65	54.00	34.13	36.15	6.71	33.65	100	109 Average
9	10593.000	53.54	-20.46	74.00	88.65	-8.46	7.80	34.45	100	0 Peak
10	10593.000	35.64	-18.36	54.00	70.75	-8.46	7.80	34.45	100	116 Average

Remark: #3 and #4 Fundamental Signal

Remark: Frequency from 25GHz to 40GHz, the emission emitted by the EUT is too low to be measured.



• Polarization : Vertical

■ The test that passed at minimum margin was marked by the boldface in the following table.



Site : 03CH04-HY
 Condition: FCC CLASS-B 3m ANT2724 VERTICAL
 EUT : N/B
 POWER : 120Vac/60Hz
 MODEL : FR 701819
 MEMO : 802.11a TX_CH60;5300MHz
 Data Rate: 24

	Freq	Level	Over Limit	Limit Line	Read Level	Antenna Factor	Cable Loss	Preamp	Ant Pos	Table Pos	Remark
	MHz	dBuV/m	dB	dBuV/m	dBuV	dB/m	dB	dB	cm	deg	
1	30.000	23.73	-16.27	40.00	34.73	16.38	0.87	28.25	---	---	Peak
2	32.700	24.41	-15.59	40.00	35.45	16.33	0.90	28.26	---	---	Peak
3	40.260	25.62	-14.38	40.00	41.46	11.46	0.97	28.28	100	146	Peak
4	828.500	24.78	-21.22	46.00	29.04	20.88	3.73	28.87	---	---	Peak
5	903.400	27.19	-18.81	46.00	28.44	23.58	3.96	28.79	---	---	Peak
6	948.900	28.59	-17.41	46.00	28.57	24.74	3.98	28.70	---	---	Peak

Remark: Frequency from 9KHz to 30MHz, the emission emitted by the EUT is too low to be measured.

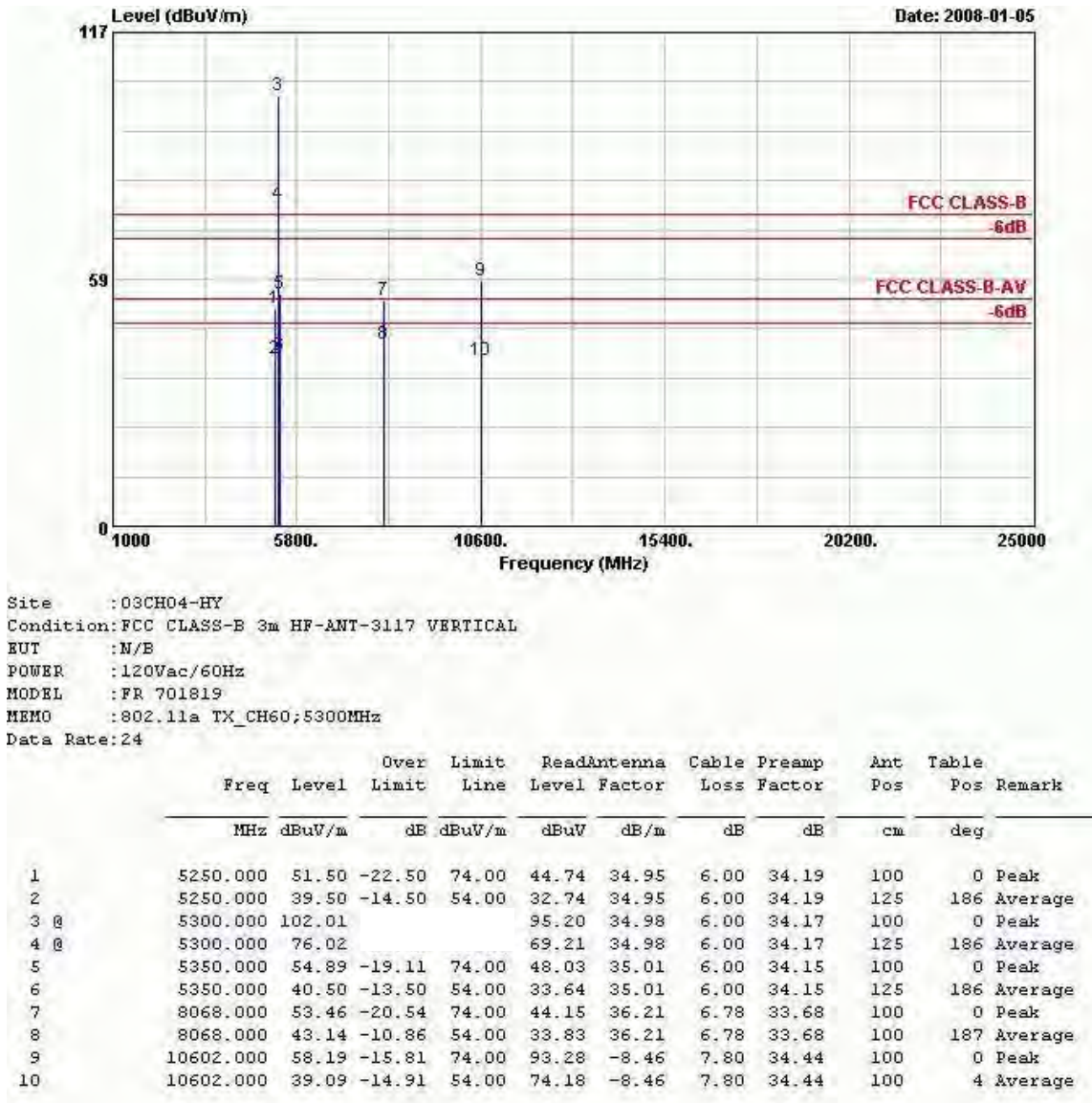

Remark: #3 and #4 Fundamental Signal

Remark: Frequency from 25GHz to 40GHz, the emission emitted by the EUT is too low to be measured.



- Test Mode : Mode 6
- Polarization : Horizontal

The test that passed at minimum margin was marked by the boldface in the following table.

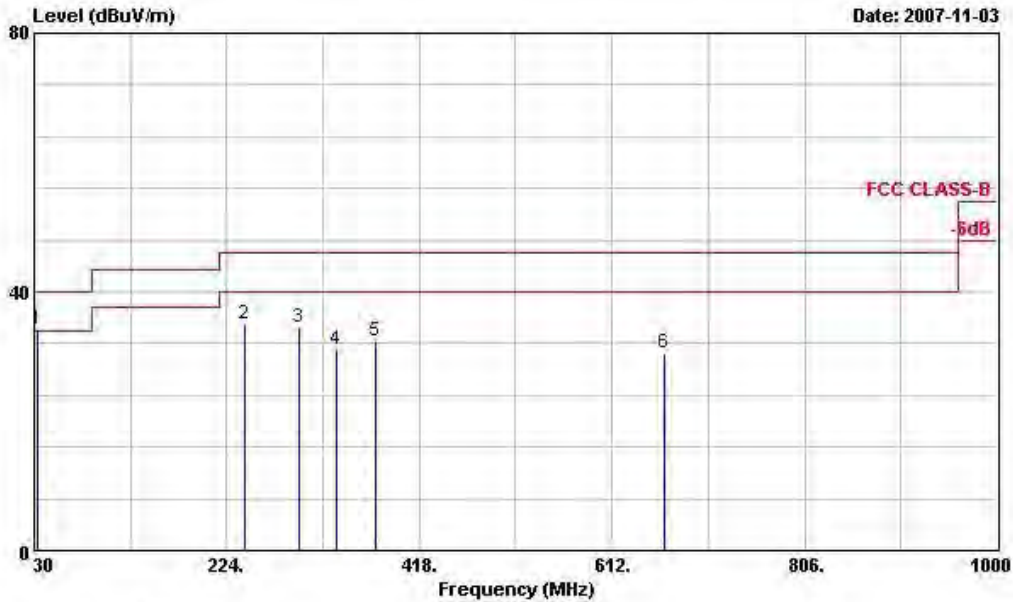

Site : 03CH04-HY
 Condition: FCC CLASS-B 3m ANT2724 HORIZONTAL
 EUT : N/B
 POWER : 120Vac/60Hz
 MODEL : FR 701819
 MEMO : 802.11a TX_CH64;5320MHz
 Data Rate: 9

	Freq	Level	Over Limit	Limit	Read	Antenna	Cable	Preamp	Ant	Table	
	MHz	dBuV/m	dB	dBuV/m	dBuV	dB/m	dB	dB	cm	deg	Remark
1	33.780	34.15	-5.85	40.00	43.59	16.31	0.91	26.66	100	171	Peak
2	242.220	34.89	-11.11	46.00	46.83	11.98	2.02	25.94	---	---	Peak
3	296.220	34.57	-11.43	46.00	45.75	12.33	2.23	25.74	---	---	Peak
4	335.000	30.97	-15.03	46.00	41.07	13.51	2.35	25.97	---	---	Peak
5	374.200	32.36	-13.64	46.00	41.23	14.88	2.49	26.24	---	---	Peak
6	665.400	30.58	-15.42	46.00	34.10	20.06	3.45	27.02	---	---	Peak

Remark: Frequency from 9KHz to 30MHz, the emission emitted by the EUT is too low to be measured.

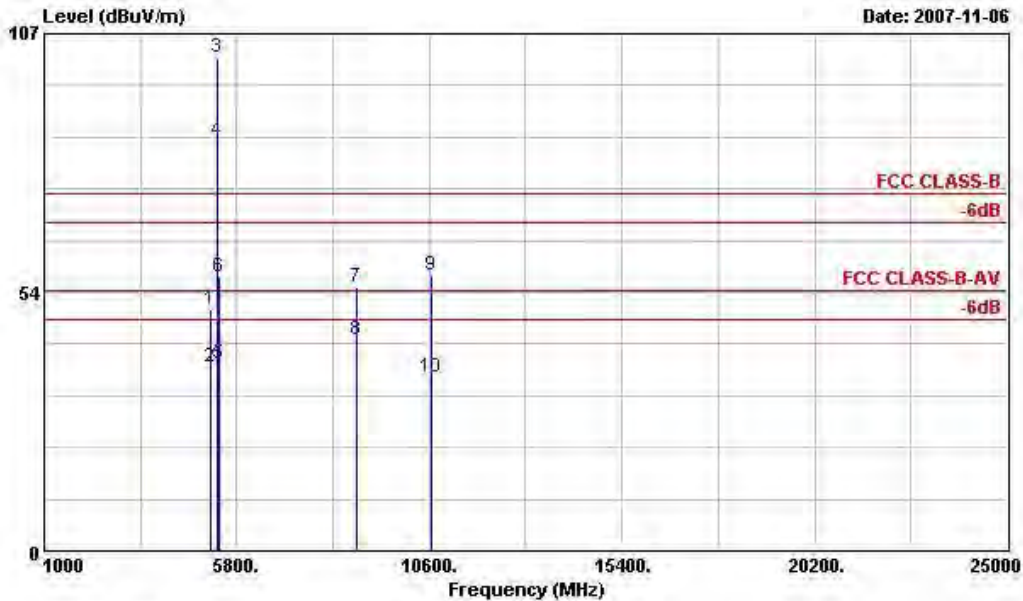

Site : 03CH04-HY
 Condition: FCC CLASS-B 3m HF-ANT-6903 HORIZONTAL
 EUT : N/B
 POWER : 120Vac/60Hz
 MODEL : FR 701819
 MEMO : 802.11a TX_CH64;5320MHz
 Data Rate: 9

	Freq	Level	Over Limit	Limit Line	ReadAntenna Level	Antenna Factor	Cable Loss	Preamp Factor	Ant Pos	Table Pos	Remark
	MHz	dBuV/m	dB	dBuV/m	dBuV	dB/m	dB	dB	cm	deg	
1	5150.000	50.04	-23.96	74.00	44.90	33.38	6.00	34.24	100	0	Peak
2	5150.000	37.86	-16.14	54.00	32.72	33.38	6.00	34.24	154	7	Average
3 @	5320.000	101.99			96.58	33.58	6.00	34.17	100	0	Peak
4 @	5320.000	84.70			79.29	33.58	6.00	34.17	154	7	Average
5	5350.000	38.88	-15.12	54.00	33.41	33.62	6.00	34.15	154	7	Average
6	5350.000	56.80	-17.20	74.00	51.33	33.62	6.00	34.15	100	0	Peak
7	8796.000	54.69	-19.31	74.00	44.30	37.86	7.17	34.64	100	0	Peak
8	8796.000	43.64	-10.36	54.00	33.25	37.86	7.17	34.64	100	173	Average
9	10638.000	57.09	-16.91	74.00	92.15	-8.44	7.80	34.42	100	0	Peak
10	10638.000	35.74	-18.26	54.00	70.80	-8.44	7.80	34.42	100	73	Average

Remark: #11 and #12 Fundamental Signal

Remark: Frequency from 25GHz to 40GHz, the emission emitted by the EUT is too low to be measured.



• Polarization : Vertical

■ The test that passed at minimum margin was marked by the boldface in the following table.

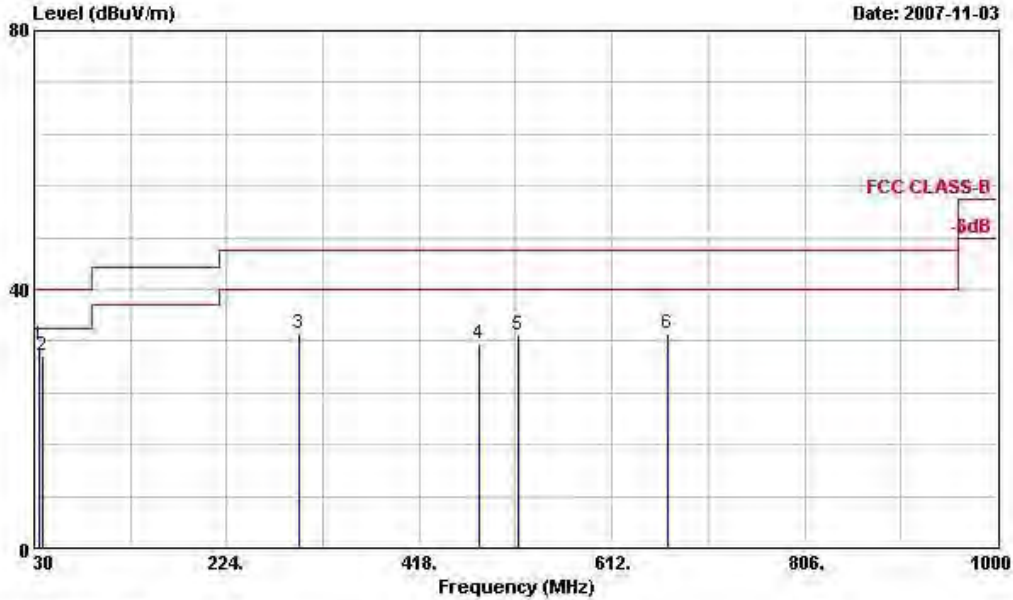

Site : 03CH04-HY
 Condition: FCC CLASS-B 3m ANT2724 VERTICAL
 EUT : N/B
 POWER : 120Vac/60Hz
 MODEL : FR 701819
 MEMO : 802.11a TX_CH64;5320MHz
 Data Rate:9

	Freq	Level	Over Limit	Limit Line	Read Level	Antenna Factor	Cable Loss	Preamp Factor	Ant Pos	Table Pos	Remark
	MHz	dBuV/m	dB	dBuV/m	dBuV	dB/m	dB	dB	cm	deg	
1	35.940	31.34	-8.66	40.00	41.67	15.40	0.93	26.65	100	144	Peak
2	39.180	29.63	-10.37	40.00	42.60	12.71	0.96	26.64	---	---	Peak
3	297.300	33.07	-12.93	46.00	44.25	12.32	2.23	25.74	---	---	Peak
4	478.500	31.70	-14.30	46.00	39.21	16.65	2.77	26.94	---	---	Peak
5	517.700	32.91	-13.09	46.00	39.67	17.43	2.88	27.07	---	---	Peak
6	668.200	33.22	-12.78	46.00	36.73	20.06	3.45	27.02	---	---	Peak

Remark: Frequency from 9KHz to 30MHz, the emission emitted by the EUT is too low to be measured.

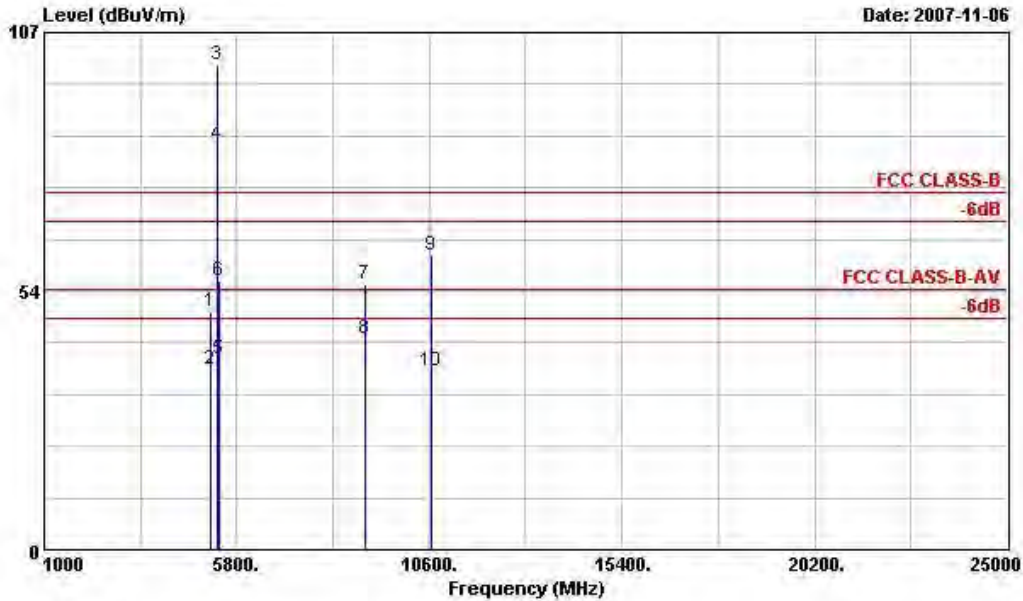

Site : 03CH04-HY
 Condition: FCC CLASS-B 3m HF-ANT-6903 VERTICAL
 EUT : N/B
 POWER : 120Vac/60Hz
 MODEL : FR 701819
 MEMO : 802.11a TX_CH64;5320MHz
 Data Rate: 9

	Freq	Level	Over	Limit	Read	Antenna	Cable	Preamp	Ant	Table	
	MHz	dBuV/m	dB	dBuV/m	Level	Factor	Loss	Factor	Pos	Pos	Remark
					dBuV	dB/m	dB	dB	cm	deg	
1	5150.000	49.13	-24.87	74.00	43.99	33.38	6.00	34.24	100	0	Peak
2	5150.000	37.22	-16.78	54.00	32.08	33.38	6.00	34.24	107	8	Average
3 @	5320.000	100.43			95.02	33.58	6.00	34.17	100	0	Peak
4 @	5320.000	83.85			78.44	33.58	6.00	34.17	107	8	Average
5	5350.000	39.25	-14.75	54.00	33.78	33.62	6.00	34.15	107	8	Average
6	5350.000	55.49	-18.51	74.00	50.02	33.62	6.00	34.15	100	0	Peak
7	8990.000	55.00	-19.00	74.00	44.43	38.08	7.27	34.78	100	0	Peak
8	8990.000	43.80	-10.20	54.00	33.23	38.08	7.27	34.78	100	139	Average
9	10641.000	60.95	-13.05	74.00	96.01	-8.44	7.80	34.42	100	0	Peak
10	10641.000	37.11	-16.89	54.00	72.17	-8.44	7.80	34.42	100	110	Average

Remark: #3 and #4 Fundamental Signal

Remark: Frequency from 25GHz to 40GHz, the emission emitted by the EUT is too low to be measured.



- Test Mode : Mode 7
- Polarization : Horizontal

The test that passed at minimum margin was marked by the boldface in the following table.

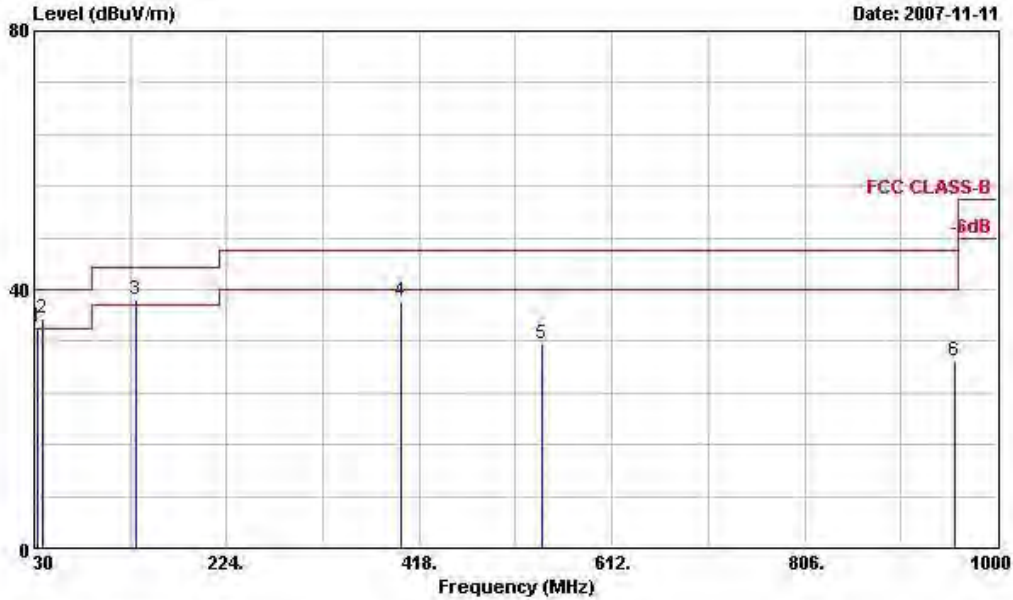

Site : 03CH04-HY
 Condition: FCC CLASS-B 3m ANT2724 HORIZONTAL
 EUT : N/B
 POWER : 120Vac/60Hz
 MODEL : FR 701819
 MEMO : 11n(a) Tx(20M)_CH36;5180MHz
 Data Rate: 48

	Freq	Level	Over Limit	Limit Line	ReadAntenna Level	Antenna Factor	Cable Loss	Preamp Factor	Ant Pos	Table Pos	Remark
	MHz	dBuV/m	dB	dBuV/m	dBuV	dB/m	dB	dB	cm	deg	
1	33.780	34.10	-5.90	40.00	45.15	16.31	0.91	28.26	---	---	Peak
2	38.100	35.62	-4.38	40.00	49.33	13.61	0.95	28.27	100	156	Peak
3	132.060	38.45	-5.05	43.50	53.68	11.28	1.56	28.07	---	---	Peak
4	399.400	38.12	-7.88	46.00	48.09	15.75	2.57	28.29	---	---	Peak
5	542.200	31.64	-14.36	46.00	39.55	18.16	2.97	29.04	---	---	Peak
6	956.600	28.83	-17.17	46.00	28.59	24.94	3.98	28.69	---	---	Peak

Remark: Frequency from 9KHz to 30MHz, the emission emitted by the EUT is too low to be measured.

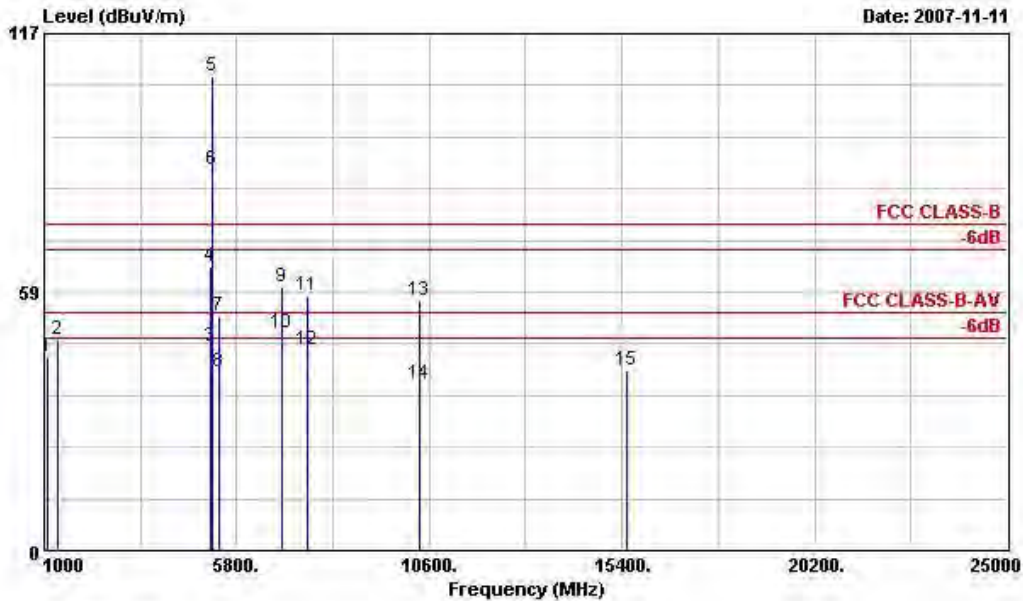

Site : 03CH04-HY
 Condition: FCC CLASS-B 3m HF-ANT-10094 HORIZONTAL
 EUT : N/B
 POWER : 120Vac/60Hz
 MODEL : FR 701819
 MEMO : 11n(a) Tx(20M)_CH36;5180MHz
 Data Rate: 48

	Freq	Level	Over	Limit	ReadAntenna	Cable	Preamp	Ant	Table	
	MHz	dBuV/m	dB	dBuV/m	dBuV	dB	dB	cm	deg	Remark
1	1094.000	43.69	-30.31	74.00	50.08	25.53	2.34	34.26	100	0 Peak
2	1334.000	47.74	-26.26	74.00	52.54	26.55	2.60	33.95	100	0 Peak
3	5150.000	46.00	-8.00	54.00	38.96	35.28	6.00	34.24	102	350 Average
4	5150.000	64.26	-9.74	74.00	57.22	35.28	6.00	34.24	100	0 Peak
5 @	5180.000	107.55			100.46	35.32	6.00	34.23	100	0 Peak
6 @	5180.000	86.12			79.03	35.32	6.00	34.23	102	350 Average
7	5350.000	52.94	-21.06	74.00	45.57	35.52	6.00	34.15	100	0 Peak
8	5350.000	40.40	-13.60	54.00	33.03	35.52	6.00	34.15	102	350 Average
9	6908.000	59.73	-14.27	74.00	47.21	38.75	6.33	32.56	100	0 Peak
10 !	6908.000	49.12	-4.88	54.00	36.60	38.75	6.33	32.56	100	124 Average
11	7572.000	57.55	-16.45	74.00	45.31	39.42	6.59	33.77	100	0 Peak
12	7572.000	45.31	-8.69	54.00	33.07	39.42	6.59	33.77	100	121 Average
13	10362.000	56.57	-17.43	74.00	92.15	-8.72	7.80	34.65	100	0 Peak
14	10362.000	37.54	-16.46	54.00	73.12	-8.72	7.80	34.65	100	76 Average
15	15537.000	40.69	-33.31	74.00	73.78	-7.26	8.69	34.52	100	0 Peak

Remark: #5 and #6 Fundamental Signal

Remark: Frequency from 25GHz to 40GHz, the emission emitted by the EUT is too low to be measured.



• Polarization : Vertical

■ The test that passed at minimum margin was marked by the boldface in the following table.

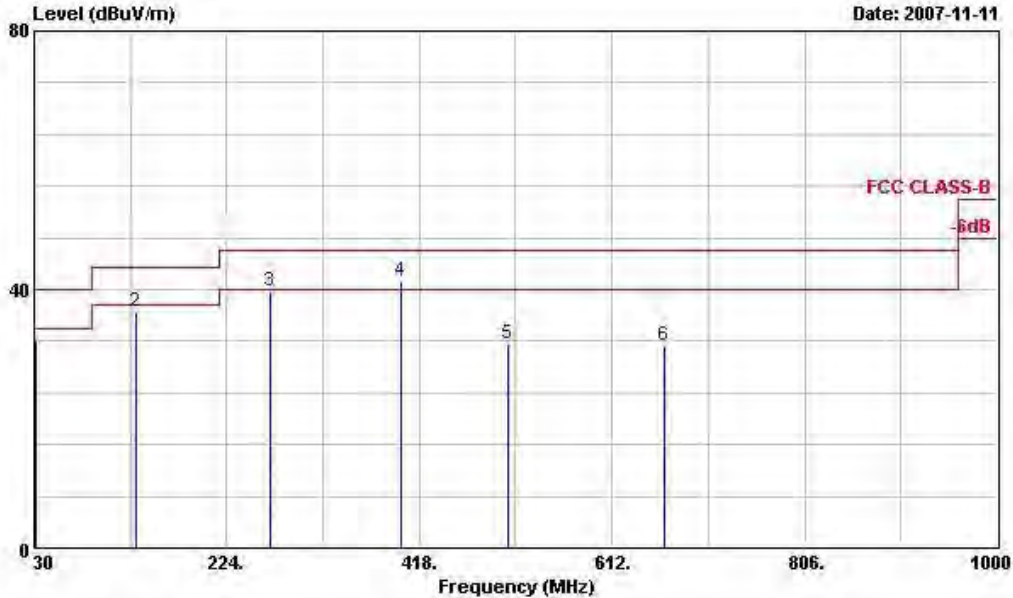

Site : 03CH04-HY
 Condition: FCC CLASS-B 3m ANT2724 VERTICAL
 EUT : N/B
 POWER : 120Vac/60Hz
 MODEL : FR 701819
 MEMO : 11n(a) Tx(20M)_CH36;5180MHz
 Data Rate: 48

	Freq	Level	Over Limit	Limit Line	ReadAntenna Level	Antenna Factor	Cable Loss	Preamp Factor	Ant Pos	Table Pos	Remark
	MHz	dBuV/m	dB	dBuV/m	dBuV	dB/m	dB	dB	cm	deg	
1	31.620	32.42	-7.58	40.00	43.46	16.34	0.88	28.26	---	---	Peak
2	132.060	36.69	-6.81	43.50	51.92	11.28	1.56	28.07	---	---	Peak
3	268.410	39.61	-6.39	46.00	52.68	12.47	2.12	27.66	---	---	Peak
4	400.100	41.41	-4.59	46.00	51.37	15.76	2.58	28.30	100	147	Peak
5	506.500	31.66	-14.34	46.00	40.75	17.08	2.84	29.01	---	---	Peak
6	665.400	31.34	-14.66	46.00	36.94	20.06	3.45	29.10	---	---	Peak

Remark: Frequency from 9KHz to 30MHz, the emission emitted by the EUT is too low to be measured.

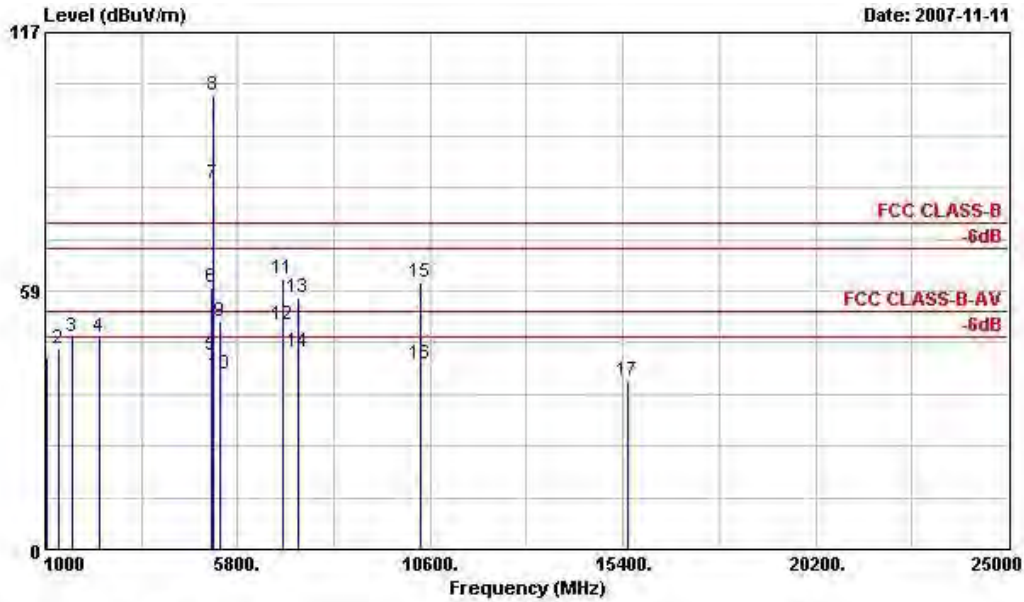

Site : 03CH04-HY
 Condition: FCC CLASS-B 3m HF-ANT-10094 VERTICAL
 EUT : N/B
 POWER : 120Vac/60Hz
 MODEL : FR 701819
 MEMO : 11n(a) Tx(20M)_CH36;5180MHz
 Data Rate: 48

	Freq	Level	Over	Limit	ReadAntenna	Cable	Preamp	Ant	Table	
	MHz	dBuV/m	dB	dBuV/m	dBuV	dB/m	dB	dB	cm	deg
1	1052.000	43.42	-30.58	74.00	50.15	25.32	2.28	34.33	100	0 Peak
2	1334.000	45.31	-28.69	74.00	50.11	26.55	2.60	33.95	100	0 Peak
3	1668.000	48.26	-25.74	74.00	50.52	28.47	2.97	33.70	100	0 Peak
4	2334.000	48.12	-25.88	74.00	47.66	30.54	3.69	33.77	100	0 Peak
5	5150.000	43.98	-10.02	54.00	36.89	35.32	6.00	34.23	100	30 Average
6	5150.000	59.43	-14.57	74.00	52.34	35.32	6.00	34.23	100	0 Peak
7 X	5180.000	82.73			75.64	35.32	6.00	34.23	100	30 Average
8 @	5180.000	102.89			95.80	35.32	6.00	34.23	100	0 Peak
9	5350.000	51.52	-22.48	74.00	44.15	35.52	6.00	34.15	100	0 Peak
10	5350.000	39.69	-14.31	54.00	32.32	35.52	6.00	34.15	100	30 Average
11	6908.000	61.36	-12.64	74.00	48.84	38.75	6.33	32.56	100	0 Peak
12	6908.000	50.98	-3.02	54.00	38.46	38.75	6.33	32.56	100	211 Average
13	7310.000	57.06	-16.94	74.00	44.53	39.32	6.48	33.28	100	0 Peak
14	7310.000	44.53	-9.47	54.00	32.00	39.32	6.48	33.28	100	49 Average
15	10362.000	60.35	-13.65	74.00	95.93	-8.72	7.80	34.65	100	0 Peak
16	10362.000	42.14	-11.86	54.00	77.72	-8.72	7.80	34.65	100	165 Average
17	15537.000	38.06	-35.94	74.00	71.01	-7.12	8.69	34.52	100	0 Peak

Remark: #7 and #8 Fundamental Signal

Remark: Frequency from 25GHz to 40GHz, the emission emitted by the EUT is too low to be measured.



- Test Mode : Mode 8
- Polarization : Horizontal

The test that passed at minimum margin was marked by the boldface in the following table.

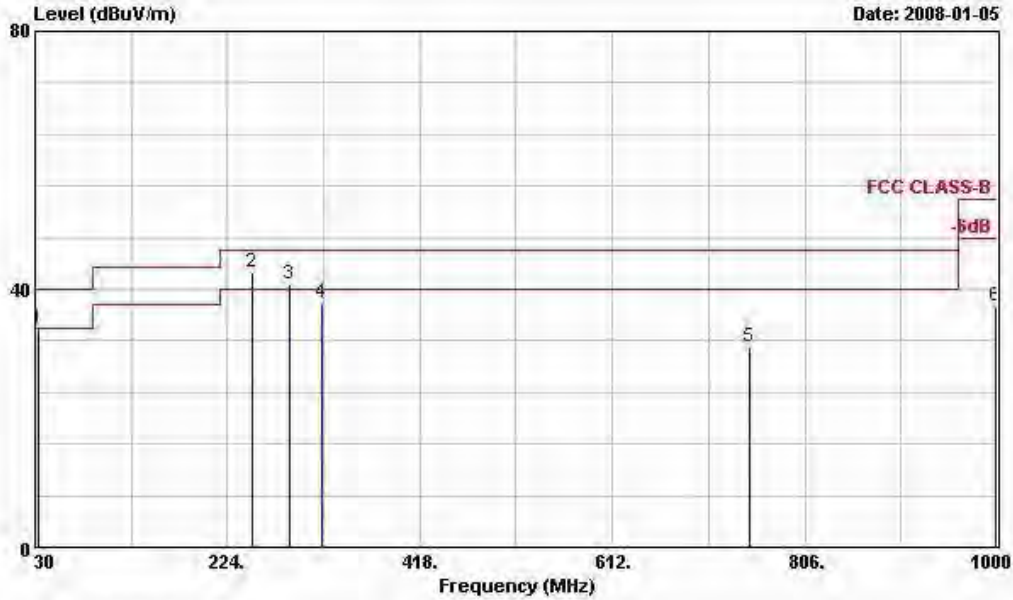

Site : 03CH04-HY
 Condition: FCC CLASS-B 3m ANT2724 HORIZONTAL
 EUT : N/B
 POWER : 120Vac/60Hz
 MODEL : FR 701819
 MEMO : 11n(a) Tx(20M)_CH44;5220MHz
 Data Rate: 48

	Freq	Level	Over Limit	Limit	ReadAntenna	Cable	Preamp	Ant	Table		
	MHz	dBuV/m	dB	dBuV/m	dBuV	Loss	Factor	Pos	Pos	Remark	
					dE/m	dB	dB	cm	deg		
1	34.050	33.97	-6.03	40.00	45.02	16.31	0.91	28.26	---	---	Peak
2	248.970	42.51	-3.49	46.00	55.67	12.50	2.05	27.70	100	214	Peak
3	286.500	40.77	-5.23	46.00	53.83	12.38	2.19	27.63	---	---	Peak
4	318.900	37.82	-8.18	46.00	50.27	12.98	2.30	27.73	---	---	Peak
5	749.400	30.95	-15.05	46.00	36.39	20.00	3.56	29.00	---	---	Peak
6	998.600	37.36	-16.64	54.00	35.94	26.03	4.00	28.60	---	---	Peak

Remark: Frequency from 9KHz to 30MHz, the emission emitted by the EUT is too low to be measured.

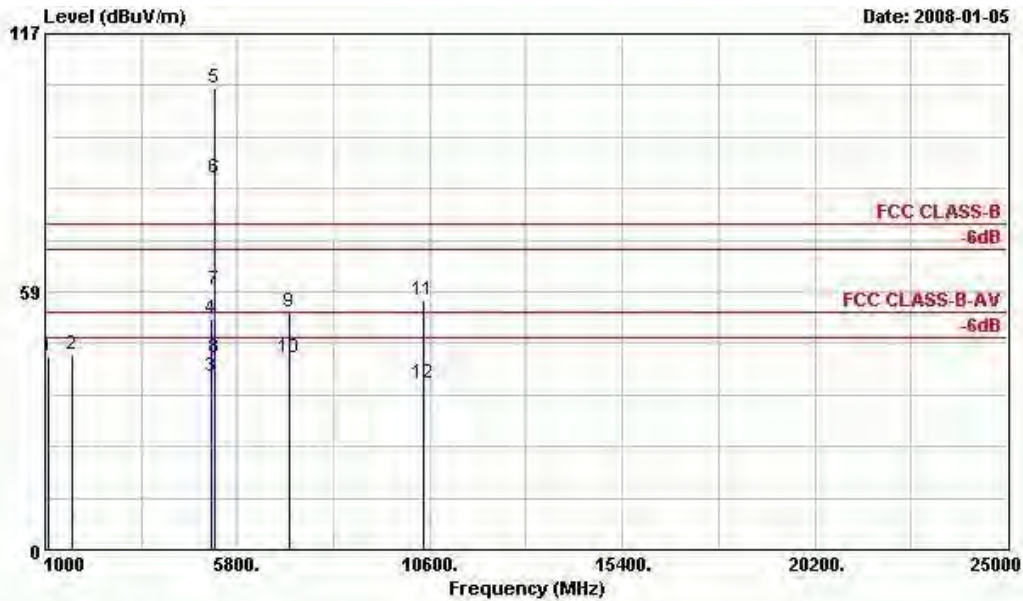

Site : 03CH04-HY
 Condition: FCC CLASS-B 3m HF-ANT-3117 HORIZONTAL
 EUT : N/B
 POWER : 120Vac/60Hz
 MODEL : FR 701819
 MEMO : 1ln(a) Tx(20M)_CH44:5220MHz
 Data Rate: 48

	Freq	Level	Over	Limit	Read	Antenna	Cable	Preamp	Ant	Table	
	MHz	dBuV/m	dB	dBuV/m	Level	Factor	Loss	Factor	Pos	Pos	Remark
					dBV	dB/m	dB	dB	cm	deg	
1	1070.000	43.98	-30.02	74.00	47.61	28.36	2.31	34.30	100	0	Peak
2	1662.000	44.11	-29.89	74.00	44.94	29.90	2.97	33.70	100	0	Peak
3	5150.000	39.08	-14.92	54.00	32.43	34.89	6.00	34.24	148	186	Average
4	5150.000	52.31	-21.69	74.00	45.66	34.89	6.00	34.24	100	0	Peak
5 @	5220.000	104.84			98.13	34.93	6.00	34.22	100	0	Peak
6 @	5220.000	84.14			77.43	34.93	6.00	34.22	148	186	Average
7	5250.000	58.93	-15.07	74.00	52.17	34.95	6.00	34.19	100	0	Peak
8	5250.000	43.47	-10.53	54.00	36.71	34.95	6.00	34.19	148	186	Average
9	7084.000	53.95	-20.05	74.00	44.31	36.00	6.40	32.76	100	0	Peak
10	7084.000	43.31	-10.69	54.00	33.67	36.00	6.40	32.76	100	185	Average
11	10437.000	56.55	-17.45	74.00	91.92	-8.60	7.80	34.58	100	0	Peak
12	10437.000	37.54	-16.46	54.00	72.91	-8.60	7.80	34.58	100	12	Average

Remark: #5 and #6 Fundamental Signal

Remark: Frequency from 25GHz to 40GHz, the emission emitted by the EUT is too low to be measured.



• Polarization : Vertical

■ The test that passed at minimum margin was marked by the boldface in the following table.

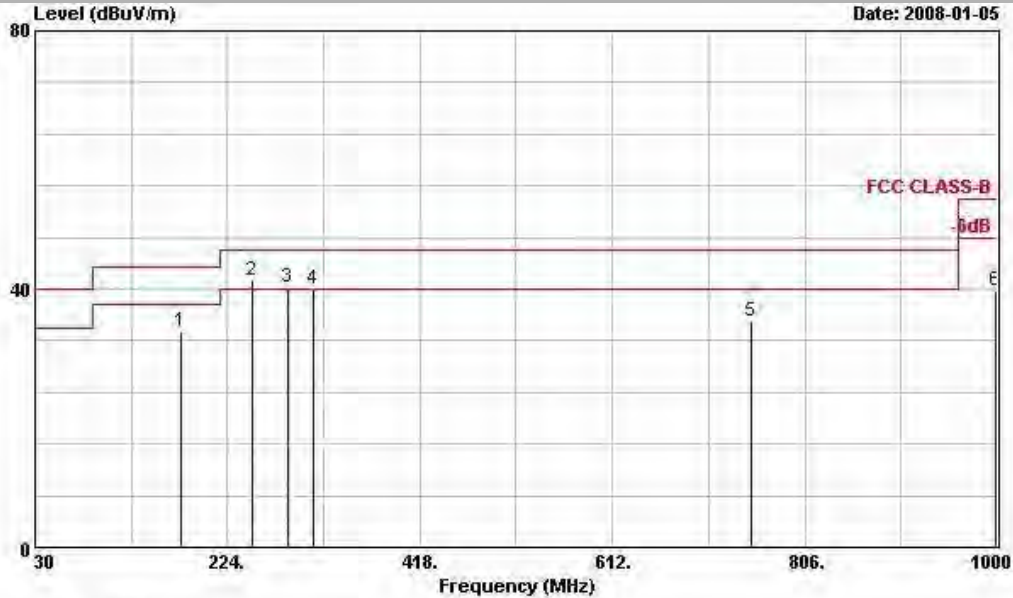

Site : 03CH04-HY
 Condition: FCC CLASS-B 3m ANT2724 VERTICAL
 EUT : N/B
 POWER : 120Vac/60Hz
 MODEL : FR 701819
 MEMO : 1ln(a) Tx(20M)_CH44;5220MHz
 Data Rate: 48

	Freq	Level	Over	Limit	ReadAntenna	Cable	Preamp	Ant	Table		
	MHz	dBuV/m	dB	dBuV/m	dBuV	Loss	Factor	Pos	Pos	Remark	
					dB/m	dB	dB	cm	deg		
1	176.340	33.43	-10.07	43.50	50.95	8.61	1.77	27.90	---	---	Peak
2	248.970	41.24	-4.76	46.00	54.40	12.50	2.05	27.70	100	164	Peak
3	284.340	40.33	-5.67	46.00	53.39	12.39	2.18	27.63	---	---	Peak
4	310.500	40.02	-5.98	46.00	52.74	12.68	2.28	27.68	---	---	Peak
5	752.200	35.03	-10.97	46.00	40.48	19.99	3.56	29.00	---	---	Peak
6	998.600	39.84	-14.16	54.00	38.42	26.03	4.00	28.60	---	---	Peak

Remark: Frequency from 9KHz to 30MHz, the emission emitted by the EUT is too low to be measured.

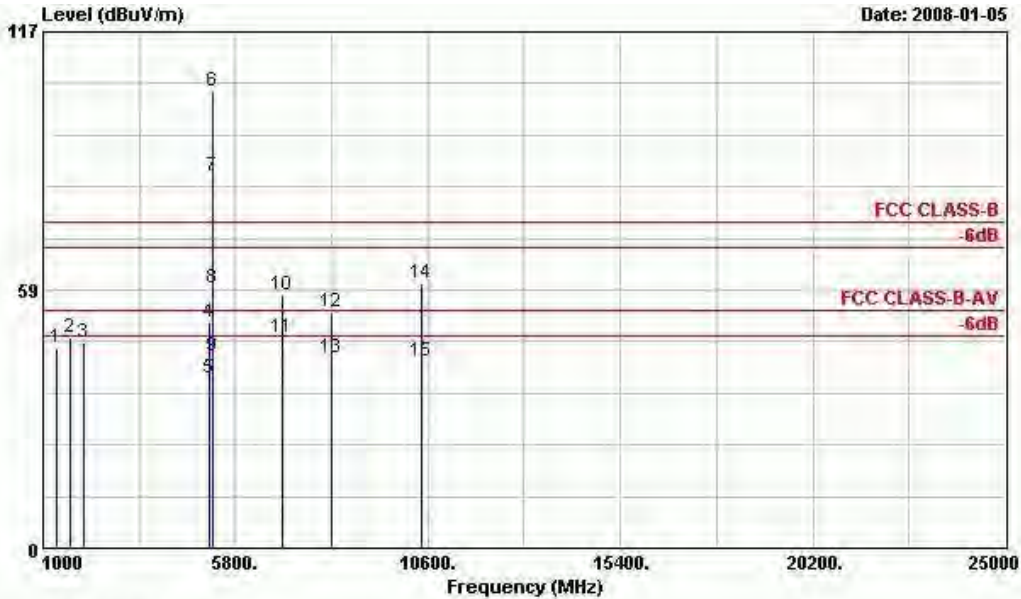

Site : 03CH04-HY
 Condition: FCC CLASS-B 3m HF-ANT-3117 VERTICAL
 EUT : N/B
 POWER : 120Vac/60Hz
 MODEL : FR 701819
 MEMO : 1ln(a) Tx(20M)_CH44:5220MHz
 Data Rate: 48

	Freq	Level	Over	Limit	ReadAntenna	Cable	Preamp	Ant	Table	
	MHz	dBuV/m	dB	dBuV/m	dBuV	Loss	Factor	Pos	Pos	Remark
					dB/m	dB	dB	cm	deg	
1	1332.000	45.39	-28.61	74.00	48.16	28.58	2.60	33.95	100	0 Peak
2	1662.000	47.79	-26.21	74.00	48.62	29.90	2.97	33.70	100	0 Peak
3	2004.000	46.49	-27.51	74.00	44.55	32.30	3.34	33.70	100	0 Peak
4	5150.000	51.37	-22.63	74.00	44.72	34.89	6.00	34.24	100	0 Peak
5	5150.000	38.49	-15.51	54.00	31.84	34.89	6.00	34.24	100	4 Average
6 X	5220.000	103.63			96.92	34.93	6.00	34.22	100	0 Peak
7 @	5220.000	84.12			77.41	34.93	6.00	34.22	100	4 Average
8	5250.000	58.91	-15.09	74.00	52.15	34.95	6.00	34.19	100	0 Peak
9	5250.000	43.63	-10.37	54.00	36.87	34.95	6.00	34.19	100	4 Average
10	6958.000	57.38	-16.62	74.00	47.56	36.00	6.34	32.52	100	0 Peak
11	6958.000	47.55	-6.45	54.00	37.73	36.00	6.34	32.52	110	135 Average
12	8190.000	53.39	-20.61	74.00	44.19	36.24	6.86	33.89	100	0 Peak
13	8190.000	43.18	-10.82	54.00	33.98	36.24	6.86	33.89	100	132 Average
14	10437.000	60.15	-13.85	74.00	95.52	-8.60	7.80	34.58	100	0 Peak
15	10437.000	42.25	-11.75	54.00	77.62	-8.60	7.80	34.58	100	11 Average

Remark: #6 and #7 Fundamental Signal

Remark: Frequency from 25GHz to 40GHz, the emission emitted by the EUT is too low to be measured.



- Test Mode : Mode 9
- Polarization : Horizontal

The test that passed at minimum margin was marked by the boldface in the following table.

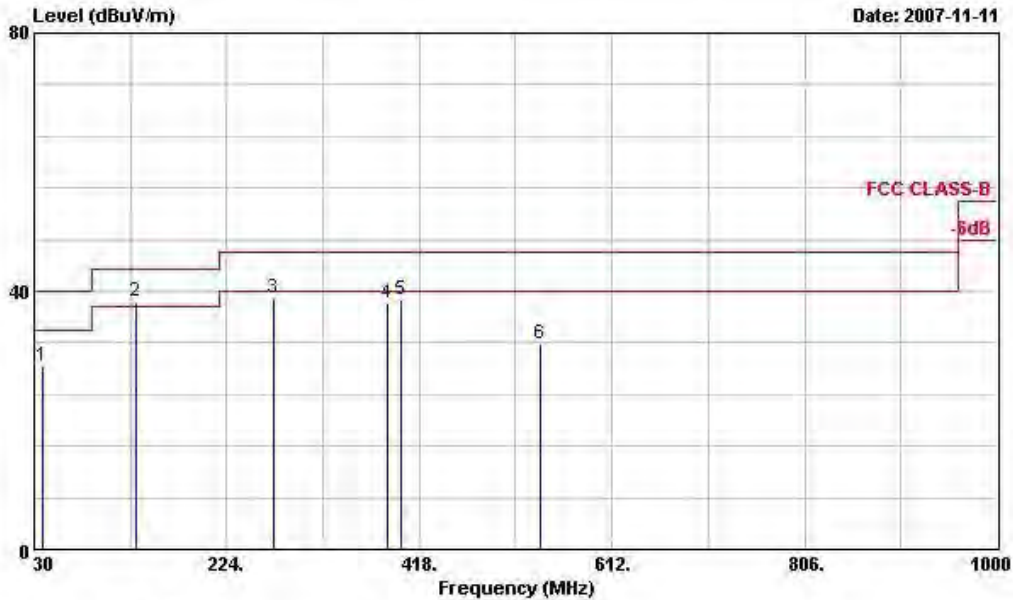

Site : 03CH04-HY
 Condition: FCC CLASS-B 3m ANT2724 HORIZONTAL
 EUT : N/B
 POWER : 120Vac/60Hz
 MODEL : FR 701819
 MEMO : 11n(a) Tx (20M)_CH48;5240MHZ
 Data Rate: 48

	Freq	Level	Over Limit	Limit Line	Read Antenna Level	Antenna Factor	Cable Loss	Preamp Factor	Ant Pos	Table Pos	Remark
	MHz	dBuV/m	dB	dBuV/m	dBuV	dB/m	dB	dB	cm	deg	
1	38.370	28.43	-11.57	40.00	43.04	12.71	0.95	28.27	---	---	Peak
2	132.060	38.51	-4.99	43.50	53.74	11.28	1.56	28.07	100	177	Peak
3	271.380	39.07	-6.93	46.00	52.14	12.46	2.13	27.66	---	---	Peak
4	385.400	38.28	-7.72	46.00	48.70	15.25	2.53	28.20	---	---	Peak
5	399.400	38.56	-7.44	46.00	48.53	15.75	2.57	28.29	---	---	Peak
6	539.400	31.74	-14.26	46.00	39.75	18.07	2.96	29.04	---	---	Peak

Remark: Frequency from 9KHz to 30MHz, the emission emitted by the EUT is too low to be measured.

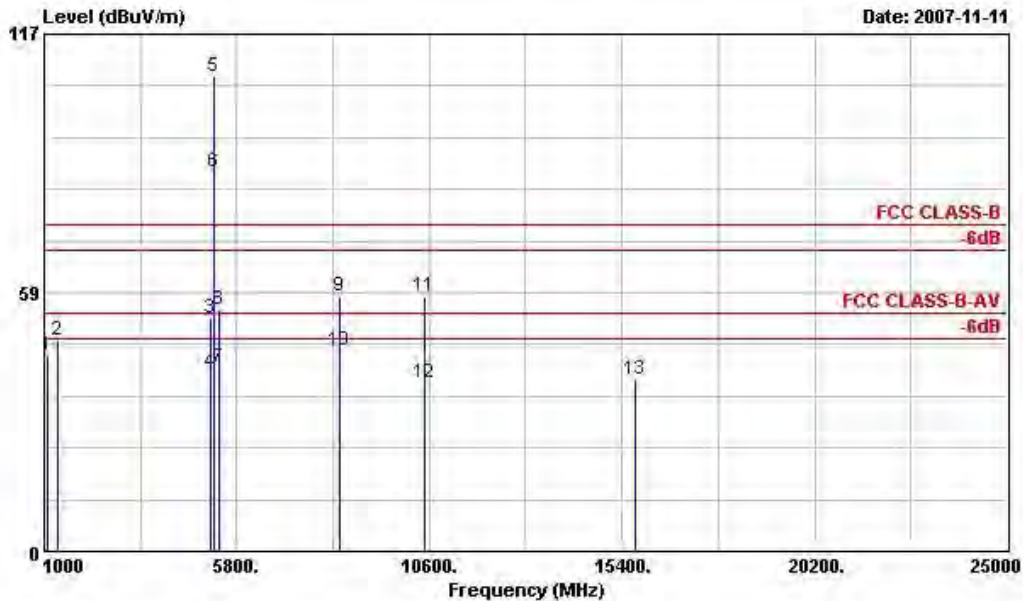

Site : 03CH04-HY
 Condition: FCC CLASS-B 3m HF-ANT-10094 HORIZONTAL
 EUT : N/B
 POWER : 120Wac/60Hz
 MODEL : FR 701819
 MEMO : 11n(a) Tx(20M)_CH48;5240MHz
 Data Rate: 48

	Freq	Level	Over Limit	Limit Line	ReadAntenna Level	Antenna Factor	Cable Loss	Preamp Factor	Ant Pos	Table Pos	Remark
	MHz	dBuV/m	dB	dBuV/m	dBuV	dB/m	dB	dB	cm	deg	
1	1084.000	44.19	-29.81	74.00	50.69	25.46	2.34	34.30	100	0	Peak
2	1332.000	47.63	-26.37	74.00	52.43	26.55	2.60	33.95	100	0	Peak
3	5150.000	52.67	-21.33	74.00	45.63	35.28	6.00	34.24	100	0	Peak
4	5150.000	40.30	-13.70	54.00	33.26	35.28	6.00	34.24	110	355	Average
5 @	5240.000	107.27			100.10	35.38	6.00	34.21	100	0	Peak
6 @	5240.000	85.84			78.67	35.38	6.00	34.21	110	355	Average
7	5950.000	41.64	-12.36	54.00	34.27	35.52	6.00	34.15	110	355	Average
8	5350.000	54.67	-19.33	74.00	47.30	35.52	6.00	34.15	100	0	Peak
9	8350.000	57.59	-16.41	74.00	45.30	39.50	6.93	34.15	100	0	Peak
10	8350.000	45.30	-8.70	54.00	33.01	39.50	6.93	34.15	100	154	Average
11	10482.000	57.59	-16.41	74.00	92.85	-8.53	7.80	34.53	100	0	Peak
12	10482.000	38.14	-15.86	54.00	73.40	-8.53	7.80	34.53	100	187	Average
13	15714.000	39.03	-34.97	74.00	70.90	-5.93	8.73	34.67	100	0	Peak

Remark: #5 and #6 Fundamental Signal

Remark: Frequency from 25GHz to 40GHz, the emission emitted by the EUT is too low to be measured.



• Polarization : Vertical

■ The test that passed at minimum margin was marked by the boldface in the following table.

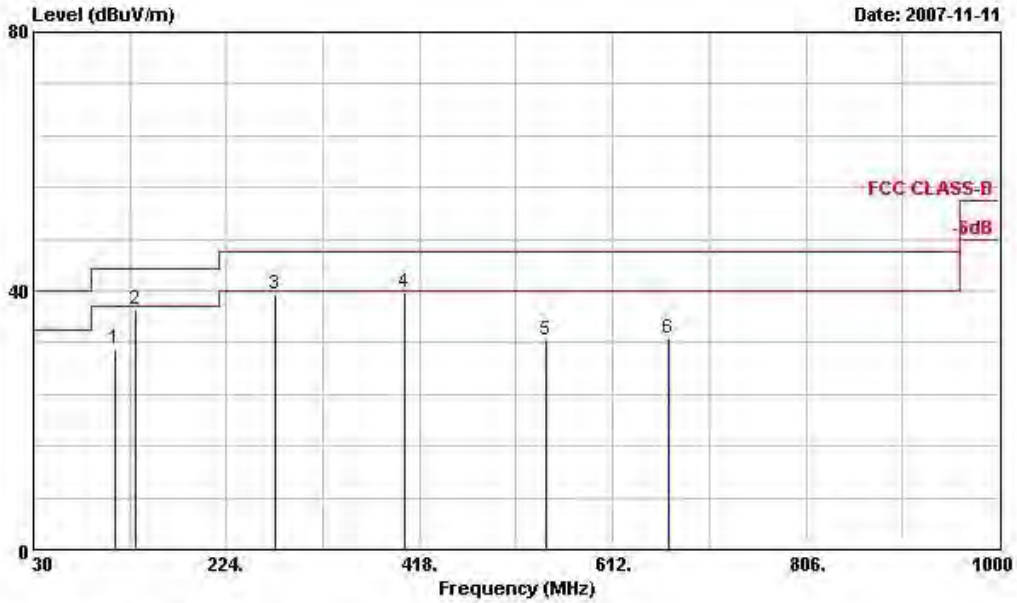

Site : 03CH04-HY
 Condition: FCC CLASS-B 3m ANT2724 VERTICAL
 EUT : N/B
 POWER : 120Vac/60Hz
 MODEL : FR 701819
 MEMO : 11n(a) Tx(20M)_CH48;5240MHz
 Data Rate: 48

	Freq	Level	Over Limit	Limit Line	Read Level	Antenna Factor	Cable Loss	Preamp Factor	Ant Pos	Table Pos	Remark
	MHz	dBuV/m	dB	dBuV/m	dBuV	dB/m	dB	dB	cm	deg	
1	111.810	31.06	-12.44	43.50	48.23	9.54	1.43	28.15	---	---	Peak
2	132.330	37.01	-6.49	43.50	52.22	11.28	1.57	28.07	---	---	Peak
3	272.730	39.38	-6.62	46.00	52.44	12.45	2.14	27.66	---	---	Peak
4	402.200	39.65	-6.35	46.00	49.60	15.78	2.58	28.31	100	168	Peak
5	545.000	32.24	-13.76	46.00	40.06	18.25	2.98	29.04	---	---	Peak
6	668.200	32.73	-13.27	46.00	38.32	20.06	3.45	29.10	---	---	Peak

Remark: Frequency from 9KHz to 30MHz, the emission emitted by the EUT is too low to be measured.

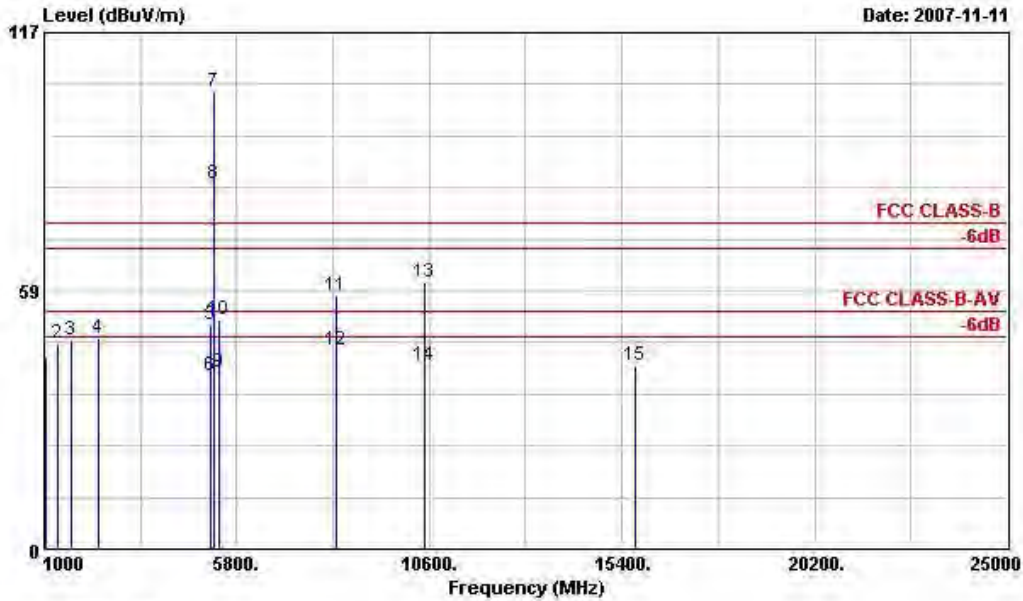

Site : 03CH04-HY
 Condition: FCC CLASS-B 3m HF-ANT-10094 VERTICAL
 EUT : N/E
 POWER : 120Vac/60Hz
 MODEL : FR 701819
 MEMO : 11n(a) Tx(20M)_CH48;5240MHz
 Data Rate: 48

	Freq	Level	Over Limit	Limit Line	ReadAntenna Level	Antenna Factor	Cable Loss	Preamp Factor	Ant Pos	Table Pos	Remark
	MHz	dBuV/m	dB	dBuV/m	dBuV	dB/m	dB	dB	cm	deg	
1	1052.000	43.63	-30.37	74.00	50.36	25.32	2.28	34.33	100	0	Peak
2	1332.000	46.50	-27.50	74.00	51.30	26.55	2.60	33.95	100	0	Peak
3	1668.000	47.18	-26.82	74.00	49.44	28.47	2.97	33.70	100	0	Peak
4	2336.000	47.66	-26.34	74.00	47.22	30.52	3.69	33.77	100	0	Peak
5	5150.000	50.82	-23.18	74.00	43.78	35.28	6.00	34.24	100	0	Peak
6	5150.000	39.40	-14.60	54.00	32.36	35.28	6.00	34.24	120	43	Average
7 @	5240.000	103.36			96.19	35.38	6.00	34.21	100	0	Peak
8 X	5240.000	82.87			75.70	35.38	6.00	34.21	120	43	Average
9	5350.000	40.07	-13.93	54.00	32.70	35.52	6.00	34.15	120	43	Average
10	5350.000	52.03	-21.97	74.00	44.66	35.52	6.00	34.15	100	0	Peak
11	8284.000	57.29	-16.71	74.00	44.94	39.50	6.91	34.06	100	0	Peak
12	8284.000	44.94	-9.06	54.00	32.59	39.50	6.91	34.06	100	155	Average
13	10482.000	60.33	-13.67	74.00	95.59	-8.53	7.80	34.53	100	0	Peak
14	10482.000	41.54	-12.46	54.00	76.80	-8.53	7.80	34.53	100	157	Average
15	15717.000	41.42	-32.58	74.00	73.22	-5.86	8.73	34.67	100	0	Peak

Remark: #7 and #8 Fundamental Signal

Remark: Frequency from 25GHz to 40GHz, the emission emitted by the EUT is too low to be measured.



- Test Mode : Mode 10
- Polarization : Horizontal

The test that passed at minimum margin was marked by the boldface in the following table.

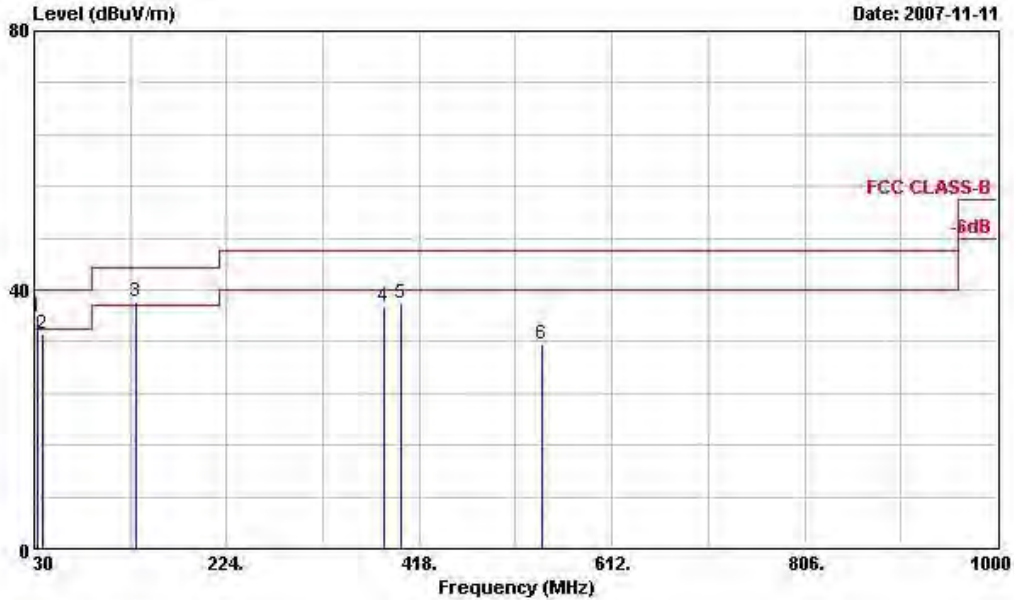

Site : 03CH04-HY
 Condition: FCC CLASS-B 3m ANT2724 HORIZONTAL
 EUT : N/B
 POWER : 120Vac/60Hz
 MODEL : FR 701819
 MEMO : 11n(a) Tx(20M)_CH52;5260MHz
 Data Rate: 48

	Freq	Level	Over Limit	Limit	ReadAntenna	Cable	Preamp	Ant	Table	
	MHz	dBuV/m	dB	dBuV/m	dBuV	dB	dB	cm	deg	Remark
1	32.700	35.27	-4.13	40.00	46.91	16.33	0.90	28.26	100	274 Peak
2	38.100	33.16	-6.84	40.00	46.87	13.61	0.95	28.27	---	Peak
3	133.140	38.20	-5.30	43.50	53.49	11.20	1.58	28.07	---	Peak
4	382.600	37.34	-8.66	46.00	47.82	15.18	2.52	28.18	---	Peak
5	399.400	37.81	-8.19	46.00	47.78	15.75	2.57	28.29	---	Peak
6	542.200	31.67	-14.33	46.00	39.58	18.16	2.97	29.04	---	Peak

Remark: Frequency from 9KHz to 30MHz, the emission emitted by the EUT is too low to be measured.

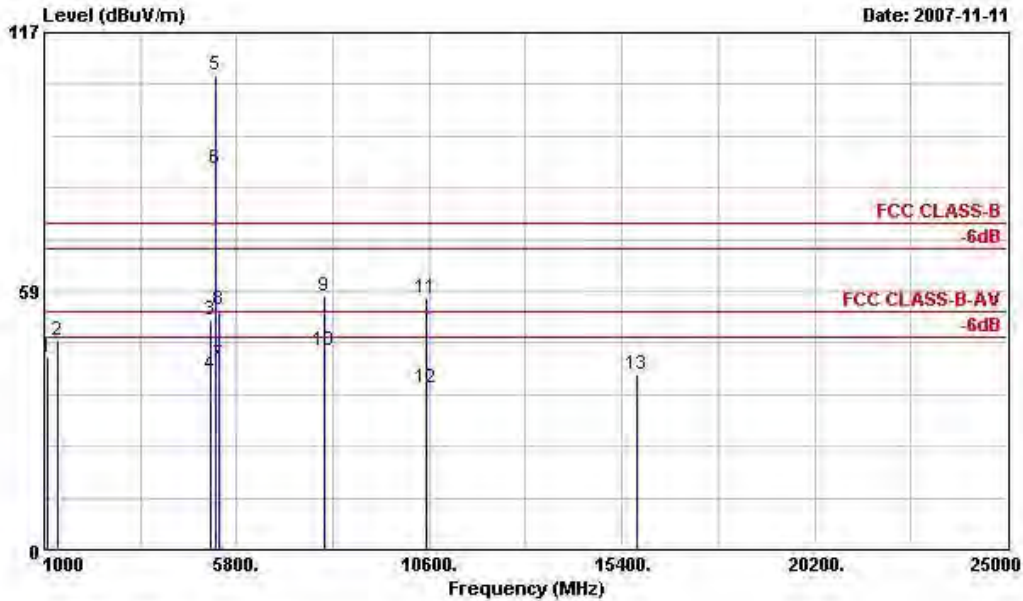

Site : 03CH04-HY
 Condition: FCC CLASS-B 3m HF-ANT-10094 HORIZONTAL
 EUT : N/E
 POWER : 120Vac/60Hz
 MODEL : FR 701819
 MEMO : 1ln(a) Tx(20M)_CH52;5260MHz
 Data Rate: 48

	Freq	Level	Over Limit	Limit Line	ReadAntenna Level	Antenna Factor	Cable Loss	Preamp Factor	Ant Pos	Table Pos	Remark
	MHz	dBuV/m	dB	dBuV/m	dBuV	dB/m	dB	dB	cm	deg	
1	1094.000	43.63	-30.37	74.00	50.02	25.53	2.34	34.26	100	0	Peak
2	1332.000	47.47	-26.53	74.00	52.27	26.55	2.60	33.95	100	0	Peak
3	5150.000	51.85	-22.15	74.00	44.81	35.28	6.00	34.24	100	0	Peak
4	5150.000	39.82	-14.18	54.00	32.78	35.28	6.00	34.24	100	356	Average
5 @	5260.000	107.57			100.34	35.42	6.00	34.19	100	0	Peak
6 X	5260.000	86.21			78.98	35.42	6.00	34.19	100	356	Average
7	5350.000	41.84	-12.16	54.00	34.47	35.52	6.00	34.15	100	356	Average
8	5350.000	54.35	-19.65	74.00	46.98	35.52	6.00	34.15	100	0	Peak
9	7966.000	57.35	-16.65	74.00	44.74	39.49	6.74	33.62	100	0	Peak
10	7966.000	44.94	-9.06	54.00	32.33	39.49	6.74	33.62	100	178	Average
11	10518.000	56.78	-17.22	74.00	91.97	-8.49	7.80	34.50	100	0	Peak
12	10518.000	36.45	-17.55	54.00	71.64	-8.49	7.80	34.50	100	47	Average
13	15786.000	39.67	-34.33	74.00	71.03	-5.37	8.74	34.73	100	0	Peak

Remark: #5 and #6 Fundamental Signal

Remark: Frequency from 25GHz to 40GHz, the emission emitted by the EUT is too low to be measured.



• Polarization : Vertical

■ The test that passed at minimum margin was marked by the boldface in the following table.

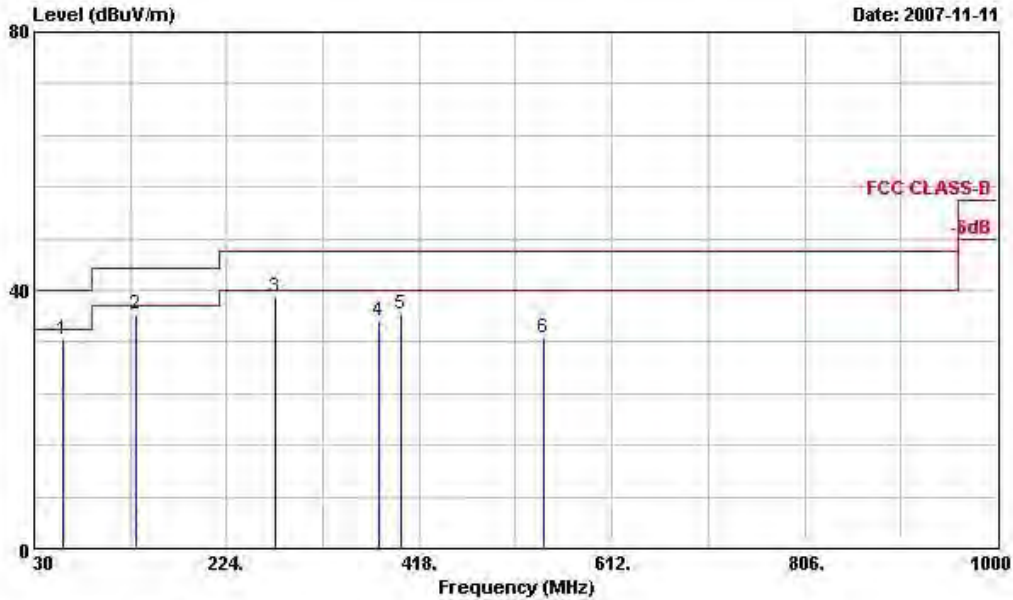

Site : 03CH04-HY
 Condition: FCC CLASS-B 3m ANT2724 VERTICAL
 EUT : N/B
 POWER : 120Wac/60Hz
 MODEL : FR 701819
 MEMO : 11n(a) Tx(20M)_CH52;5260MHz
 Data Rate: 48

	Freq	Level	Over Limit	Limit Line	ReadAntenna	Cable	Preamp	Ant	Table	Remark	
	MHz	dBuV/m	dB	dBuV/m	dBuV	dB/m	dB	dB	cm	deg	
1	58.890	32.36	-7.64	40.00	55.78	3.76	1.10	28.28	---	---	Peak
2	132.060	36.42	-7.08	43.50	51.65	11.28	1.56	28.07	---	---	Peak
3	272.730	38.99	-7.01	46.00	52.05	12.45	2.14	27.66	100	126	Peak
4	377.700	35.23	-10.77	46.00	45.89	14.98	2.50	28.14	---	---	Peak
5	399.400	36.22	-9.78	46.00	46.19	15.75	2.57	28.29	---	---	Peak
6	542.900	32.56	-13.44	46.00	40.44	18.19	2.97	29.04	---	---	Peak

Remark: Frequency from 9KHz to 30MHz, the emission emitted by the EUT is too low to be measured.

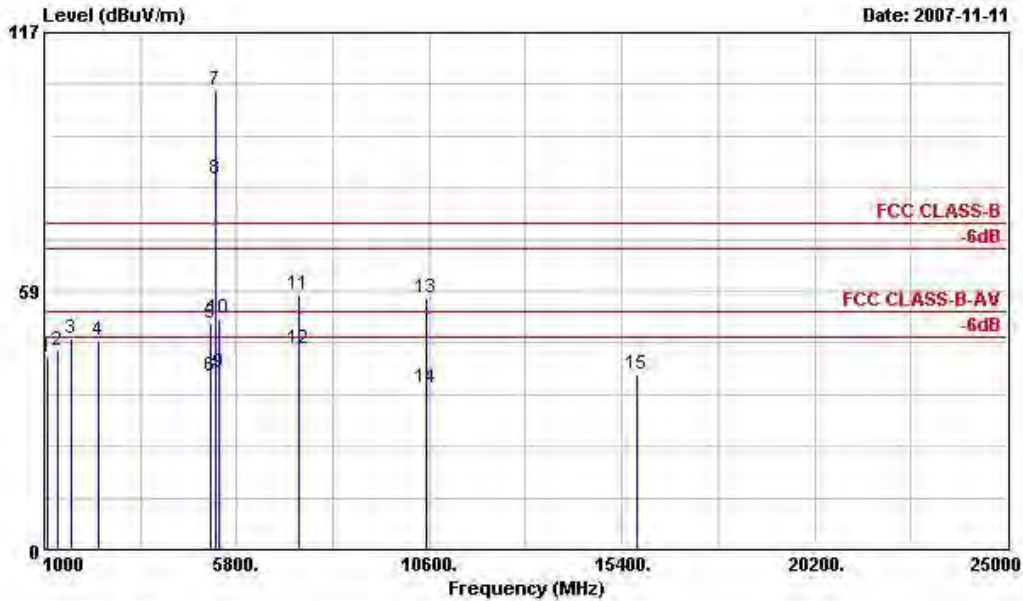

Site : 03CH04-HY
 Condition: FCC CLASS-B 3m HF-ANT-10094 VERTICAL
 EUT : N/E
 POWER : 120Vac/60Hz
 MODEL : FR 701819
 MEMO : 11n(a) Tx(20M)_CH52;5260MHz
 Data Rate: 48

	Freq	Level	Over	Limit	ReadAntenna	Cable	Preamp	Ant	Table	
	MHz	dBuV/m	dB	dBuV/m	dBuV	dB	dB	cm	deg	Remark
1	1078.000	43.39	-30.61	74.00	49.91	25.46	2.31	34.30	100	0 Peak
2	1332.000	44.97	-29.03	74.00	49.77	26.55	2.60	33.95	100	0 Peak
3	1662.000	47.71	-26.29	74.00	49.97	28.47	2.97	33.70	100	0 Peak
4	2334.000	47.48	-26.52	74.00	47.02	30.54	3.69	33.77	100	0 Peak
5	5150.000	51.32	-22.68	74.00	44.28	35.28	6.00	34.24	100	0 Peak
6	5150.000	39.26	-14.74	54.00	32.22	35.28	6.00	34.24	130	41 Average
7 X	5260.000	103.92			96.69	35.42	6.00	34.19	100	0 Peak
8 X	5260.000	83.87			76.64	35.42	6.00	34.19	130	41 Average
9	5350.000	40.10	-13.90	54.00	32.73	35.52	6.00	34.15	130	41 Average
10	5350.000	52.21	-21.79	74.00	44.84	35.52	6.00	34.15	100	0 Peak
11	7340.000	57.78	-16.22	74.00	45.36	39.34	6.49	33.41	100	0 Peak
12	7340.000	45.31	-8.69	54.00	32.89	39.34	6.49	33.41	100	115 Average
13	10518.000	56.78	-17.22	74.00	91.97	-8.49	7.80	34.50	100	0 Peak
14	10518.000	36.45	-17.55	54.00	71.64	-8.49	7.80	34.50	100	47 Average
15	15786.000	39.67	-34.33	74.00	71.03	-5.37	8.74	34.73	100	0 Peak

Remark: #7 and #8 Fundamental Signal

Remark: Frequency from 25GHz to 40GHz, the emission emitted by the EUT is too low to be measured.



- Test Mode : Mode 11
- Polarization : Horizontal

The test that passed at minimum margin was marked by the boldface in the following table.

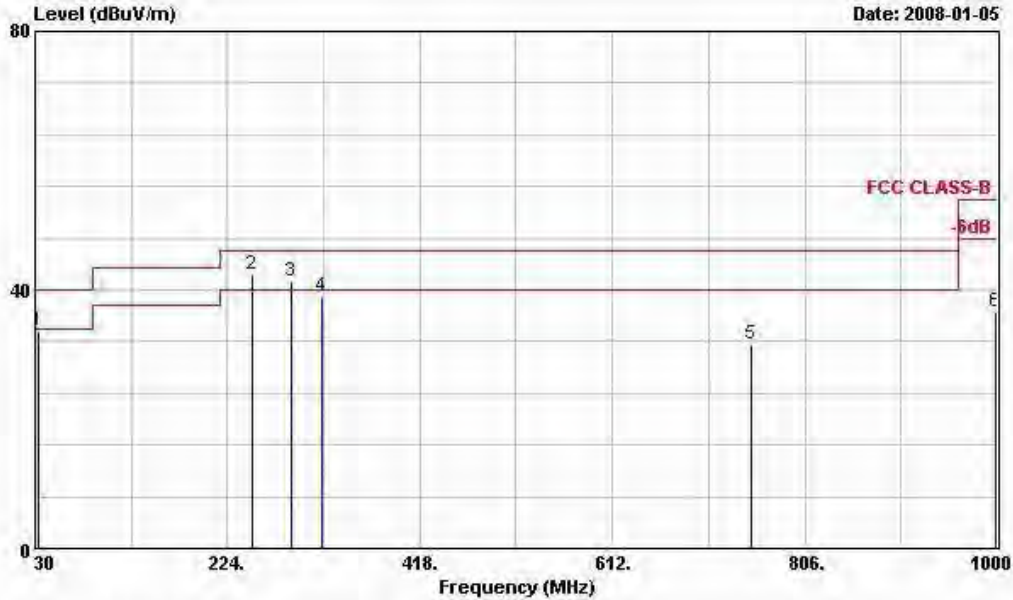

Site : 03CH04-HY
 Condition: FCC CLASS-B 3m ANT2724 HORIZONTAL
 EUT : N/B
 POWER : 120Vac/60Hz
 MODEL : FR 701819
 MEMO : 11n(a) Tx(20M)_CH60;5300MHZ
 Data Rate: 48

	Freq	Level	Over	Limit	ReadAntenna	Cable	Preamp	Ant	Table		
	MHz	dBuV/m	Limit	Line	Level	Loss	Factor	Pos	Pos	Remark	
			dB	dBuV/m	dBuV	dB	dB	cm	deg		
1	34.050	33.65	-6.35	40.00	44.70	16.31	0.91	28.26	---	---	Peak
2 @	248.970	42.32	-3.68	46.00	55.48	12.50	2.05	27.70	100	215	Peak
3 !	288.660	41.44	-4.56	46.00	54.50	12.37	2.20	27.62	---	---	Peak
4	318.900	38.89	-7.11	46.00	51.34	12.98	2.30	27.73	---	---	Peak
5	752.200	31.54	-14.46	46.00	36.99	19.99	3.56	29.00	---	---	Peak
6	998.600	36.70	-17.30	54.00	35.28	26.03	4.00	28.60	---	---	Peak

Remark: Frequency from 9KHz to 30MHz, the emission emitted by the EUT is too low to be measured.

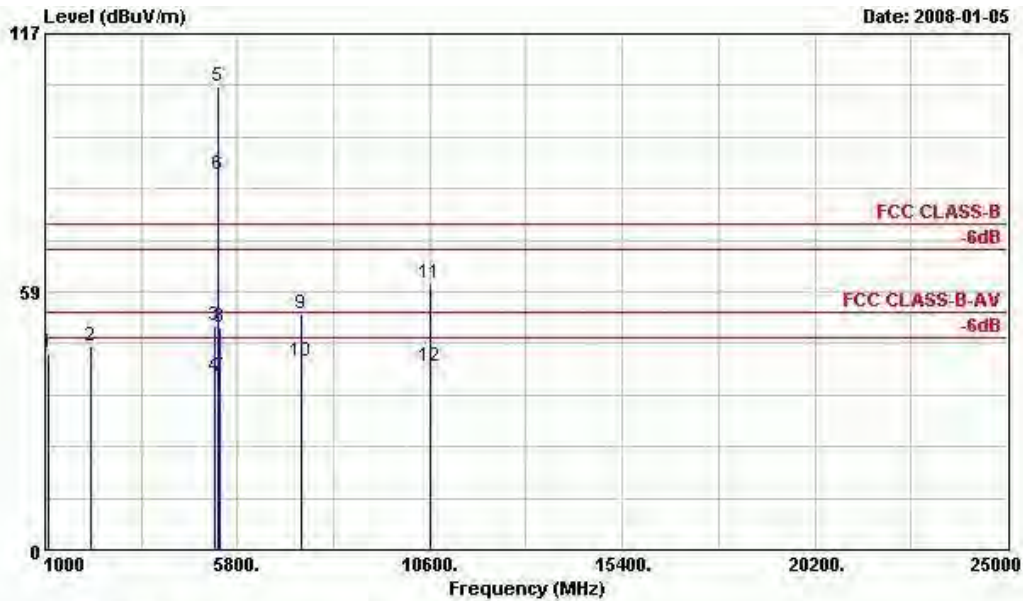

Site : 03CH04-HY
 Condition: FCC CLASS-B 3m HF-ANT-3117 HORIZONTAL
 EUT : N/B
 POWER : 120Vac/60Hz
 MODEL : FR 701819
 MEMO : 1ln(a) Tx(20M)_CH60;5300MHz
 Data Rate: 48

	Freq	Level	Over	Limit	Read	Antenna	Cable	Preamp	Ant	Table	
	MHz	dBuV/m	dB	dBuV/m	Level	Factor	Loss	Factor	Pos	Pos	Remark
					dBuV	dB/m	dB	dB	cm	deg	
1	1070.000	44.65	-29.35	74.00	48.28	28.36	2.31	34.30	100	0	Peak
2	2124.000	46.00	-28.00	74.00	43.89	32.37	3.46	33.73	100	0	Peak
3	5250.000	50.98	-23.02	74.00	44.22	34.95	6.00	34.19	100	0	Peak
4	5250.000	39.09	-14.91	54.00	32.33	34.95	6.00	34.19	100	312	Average
5 @	5300.000	105.05			98.24	34.98	6.00	34.17	100	0	Peak
6 @	5300.000	84.88			78.07	34.98	6.00	34.17	100	312	Average
7	5350.000	39.14	-14.86	54.00	32.28	35.01	6.00	34.15	100	312	Average
8	5350.000	50.54	-23.46	74.00	43.68	35.01	6.00	34.15	100	0	Peak
9	7412.000	53.39	-20.61	74.00	44.41	36.00	6.52	33.54	100	0	Peak
10	7412.000	42.87	-11.13	54.00	33.89	36.00	6.52	33.54	100	108	Average
11	10602.000	60.24	-13.76	74.00	95.33	-8.46	7.80	34.44	100	0	Peak
12	10602.000	41.38	-12.62	54.00	76.47	-8.46	7.80	34.44	100	98	Average

Remark: #5 and #6 Fundamental Signal

Remark: Frequency from 25GHz to 40GHz, the emission emitted by the EUT is too low to be measured.



• Polarization : Vertical

■ The test that passed at minimum margin was marked by the boldface in the following table.

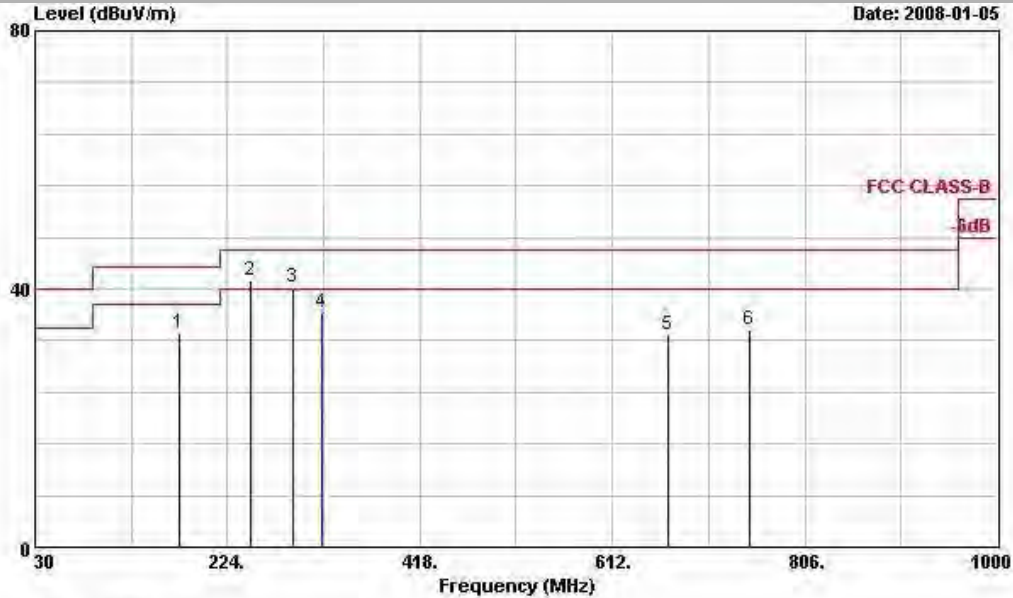

Site : 03CH04-HY
 Condition: FCC CLASS-B 3m ANT2724 VERTICAL
 EUT : N/B
 POWER : 120Vac/60Hz
 MODEL : FR 701819
 MEMO : 11n(a) Tx(20M)_CH60;5300MHz
 Data Rate: 48

	Freq	Level	Over	Limit	ReadAntenna	Cable	Preamp	Ant	Table		
	MHz	dBuV/m	dB	dBuV/m	dBuV	Loss	Factor	Pos	Pos	Remark	
					dB/m	dB	dB	cm	deg		
1	175.530	33.03	-10.47	43.50	50.68	8.49	1.76	27.90	---	---	Peak
2	247.620	41.42	-4.58	46.00	54.74	12.35	2.04	27.70	100	184	Peak
3	289.740	40.29	-5.71	46.00	53.35	12.36	2.20	27.62	---	---	Peak
4	318.900	36.44	-9.56	46.00	48.89	12.98	2.30	27.73	---	---	Peak
5	668.200	32.99	-13.01	46.00	38.58	20.06	3.45	29.10	---	---	Peak
6	750.100	33.76	-12.24	46.00	39.20	20.00	3.56	29.00	---	---	Peak

Remark: Frequency from 9KHz to 30MHz, the emission emitted by the EUT is too low to be measured.

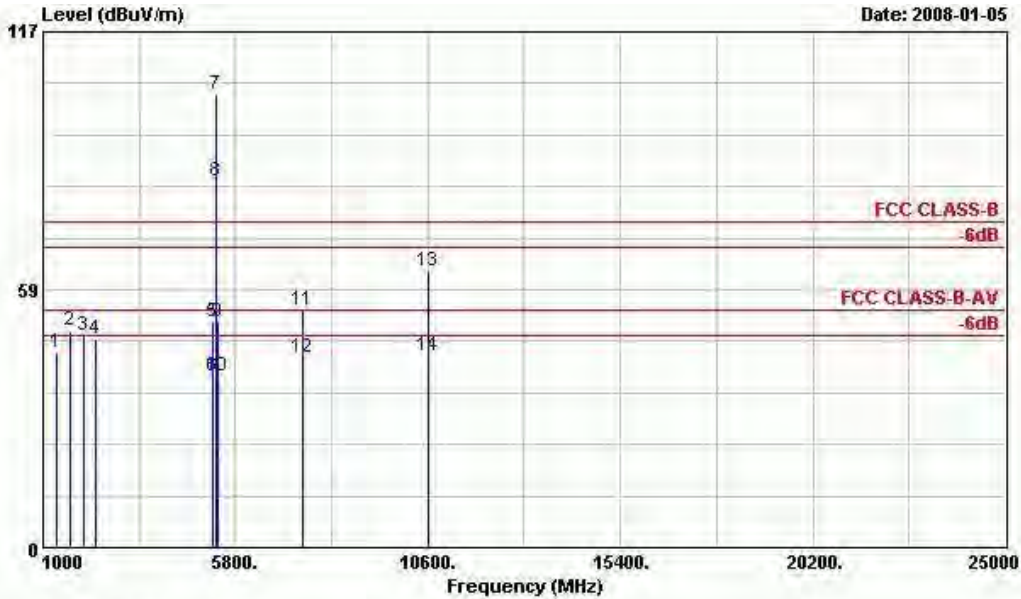

Site : 03CH04-HY
 Condition: FCC CLASS-B 3m HF-ANT-3117 VERTICAL
 EUT : N/B
 POWER : 120Vac/60Hz
 MODEL : FR 701819
 MEMO : 1ln(a) Tx(20M)_CH60;5300MHz
 Data Rate: 48

	Freq	Level	Over	Limit	Read	Antenna	Cable	Preamp	Ant	Table	
	MHz	dBuV/m	dB	dBuV/m	dBuV	dB/m	dB	dB	cm	deg	Remark
1	1332.000	44.14	-29.86	74.00	46.91	28.58	2.60	33.95	100	0	Peak
2	1668.000	49.38	-24.62	74.00	50.21	29.90	2.97	33.70	100	0	Peak
3	1998.000	47.96	-26.04	74.00	46.02	32.30	3.34	33.70	100	0	Peak
4	2332.000	47.39	-26.61	74.00	44.97	32.50	3.69	33.77	100	0	Peak
5	5250.000	51.12	-22.88	74.00	44.36	34.95	6.00	34.19	100	0	Peak
6	5250.000	38.79	-15.21	54.00	32.03	34.95	6.00	34.19	100	63	Average
7 @	5300.000	102.70			95.89	34.98	6.00	34.17	100	0	Peak
8 @	5300.000	83.25			76.44	34.98	6.00	34.17	100	63	Average
9	5350.000	51.32	-22.68	74.00	44.46	35.01	6.00	34.15	100	0	Peak
10	5350.000	38.93	-15.07	54.00	32.07	35.01	6.00	34.15	100	63	Average
11	7470.000	53.82	-20.18	74.00	45.00	36.00	6.55	33.74	100	0	Peak
12	7470.000	43.01	-10.99	54.00	34.19	36.00	6.55	33.74	100	123	Average
13	10602.000	62.59	-11.41	74.00	97.68	-8.46	7.80	34.44	100	0	Peak
14	10602.000	43.65	-10.35	54.00	78.74	-8.46	7.80	34.44	100	124	Average

Remark: #7 and #8 Fundamental Signal

Remark: Frequency from 25GHz to 40GHz, the emission emitted by the EUT is too low to be measured.



- Test Mode : Mode 12
- Polarization : Horizontal

■ The test that passed at minimum margin was marked by the boldface in the following table.

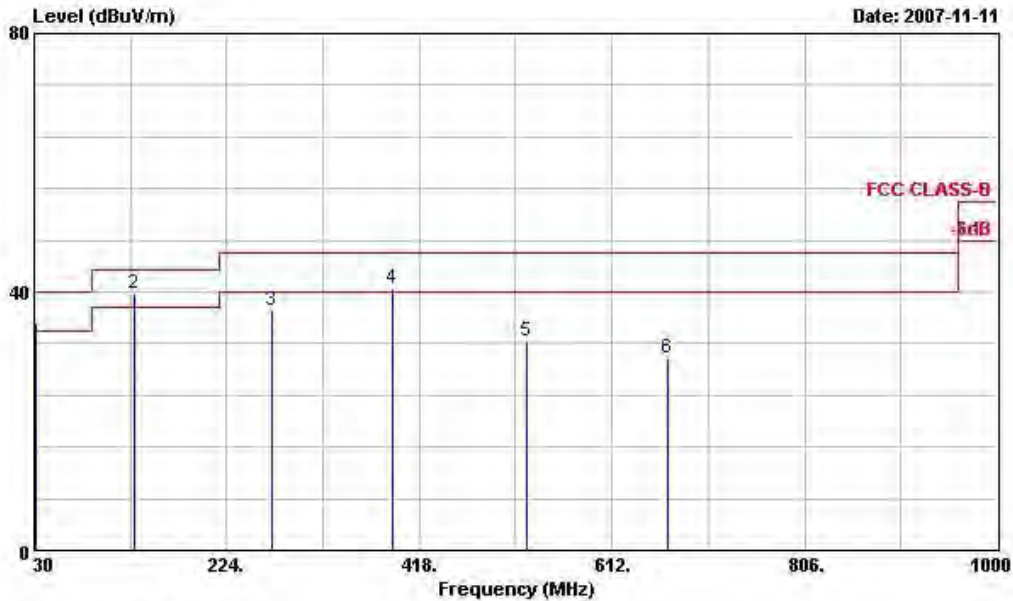

Site : 03CH04-HY
 Condition: FCC CLASS-B 3m ANT2724 HORIZONTAL
 EUT : N/B
 POWER : 120Vac/60Hz
 MODEL : FR 701819
 MEMO : 11n(a) Tx(20M)_CH64;5320MHz
 Data Rate: 48

	Freq	Level	Over Limit	Limit Line	Read Level	Antenna Factor	Cable Loss	Preamp Factor	Ant Pos	Table Pos	Remark
	MHz	dBuV/m	dB	dBuV/m	dBuV	dB/m	dB	dB	cm	deg	
1	31.890	35.27	-4.73	40.00	46.30	16.34	0.89	28.26	---	---	Peak
2	131.250	39.85	-3.65	43.50	54.99	11.37	1.56	28.08	100	133	Peak
3	269.490	37.13	-8.87	46.00	50.20	12.47	2.13	27.66	---	---	Peak
4	391.000	40.48	-5.52	46.00	50.72	15.45	2.54	28.24	---	---	Peak
5	526.100	32.39	-13.61	46.00	40.84	17.66	2.91	29.03	---	---	Peak
6	668.200	29.72	-16.28	46.00	35.31	20.06	3.45	29.10	---	---	Peak

Remark: Frequency from 9KHz to 30MHz, the emission emitted by the EUT is too low to be measured.

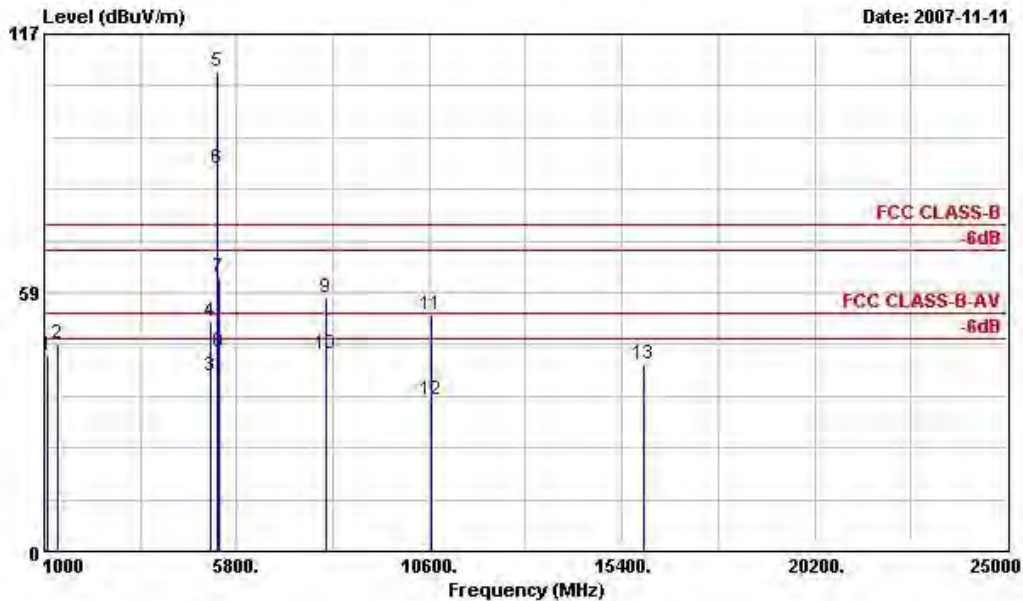

Site : 03CH04-HY
 Condition: FCC CLASS-B 3m HF-ANT-10094 HORIZONTAL
 EUT : N/B
 POWER : 120Wac/60Hz
 MODEL : FR 701819
 MEMO : 11n(a) Tx(20M)_CH64;5320MHz
 Data Rate:48

	Freq	Level	Over Limit	Limit Line	ReadAntenna Level	Antenna Factor	Cable Loss	Preamp Factor	Ant Pos	Table Pos	Remark
	MHz	dBuV/m	dB	dBuV/m	dBuV	dB/m	dB	dB	cm	deg	
1	1100.000	44.23	-29.77	74.00	50.62	25.53	2.34	34.26	100	0	Peak
2	1332.000	47.10	-26.90	74.00	51.90	26.55	2.60	33.95	100	0	Peak
3	5150.000	39.59	-14.41	54.00	32.55	35.28	6.00	34.24	100	2	Average
4	5150.000	52.07	-21.93	74.00	45.03	35.28	6.00	34.24	100	0	Peak
5 @	5320.000	108.40			101.09	35.48	6.00	34.17	100	0	Peak
6 @	5320.000	86.51			79.20	35.48	6.00	34.17	100	2	Average
7	5350.000	61.90	-12.10	74.00	54.53	35.52	6.00	34.15	100	0	Peak
8	5350.000	44.96	-9.04	54.00	37.59	35.52	6.00	34.15	100	2	Average
9	8046.000	57.22	-16.78	74.00	44.58	39.50	6.78	33.64	100	0	Peak
10	8046.000	44.57	-9.43	54.00	31.93	39.50	6.78	33.64	100	132	Average
11	10638.000	53.51	-20.49	74.00	88.57	-8.44	7.80	34.42	100	0	Peak
12	10638.000	34.14	-19.86	54.00	69.20	-8.44	7.80	34.42	100	128	Average
13	15957.000	42.23	-31.77	74.00	72.52	-4.18	8.77	34.88	100	0	Peak

Remark: #5 and #6 Fundamental Signal

Remark: Frequency from 25GHz to 40GHz, the emission emitted by the EUT is too low to be measured.



• Polarization : Vertical

■ The test that passed at minimum margin was marked by the boldface in the following table.

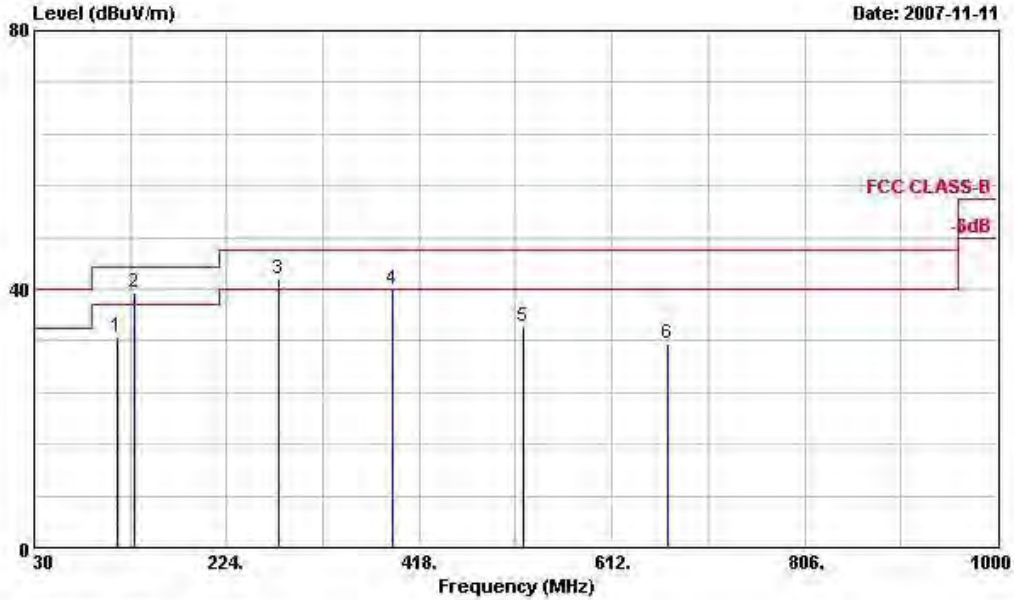

Site : 03CH04-HY
 Condition: FCC CLASS-B 3m ANT2724 VERTICAL
 EUT : N/E
 POWER : 120Vac/60Hz
 MODEL : FR 701819
 MEMO : 1ln(a) Tx(20M)_CH64;5320MHz
 Data Rate: 48

	Freq	Level	Over Limit	Limit Line	ReadAntenna Level	Antenna Factor	Cable Loss	Preamp Factor	Ant Pos	Table Pos	Remark
	MHz	dBuV/m	dB	dBuV/m	dBuV	dB/m	dB	dB	cm	deg	
1	113.700	32.58	-10.92	43.50	49.47	9.81	1.44	28.14	---	---	Peak
2	131.250	39.46	-4.04	43.50	54.60	11.37	1.56	28.08	100	187	Peak
3	275.970	41.62	-4.38	46.00	54.68	12.43	2.15	27.65	---	---	Peak
4	391.000	40.03	-5.97	46.00	50.27	15.45	2.54	28.24	---	---	Peak
5	522.600	34.09	-11.91	46.00	42.64	17.58	2.89	29.02	---	---	Peak
6	668.200	31.61	-14.39	46.00	37.20	20.06	3.45	29.10	---	---	Peak

Remark: Frequency from 9KHz to 30MHz, the emission emitted by the EUT is too low to be measured.

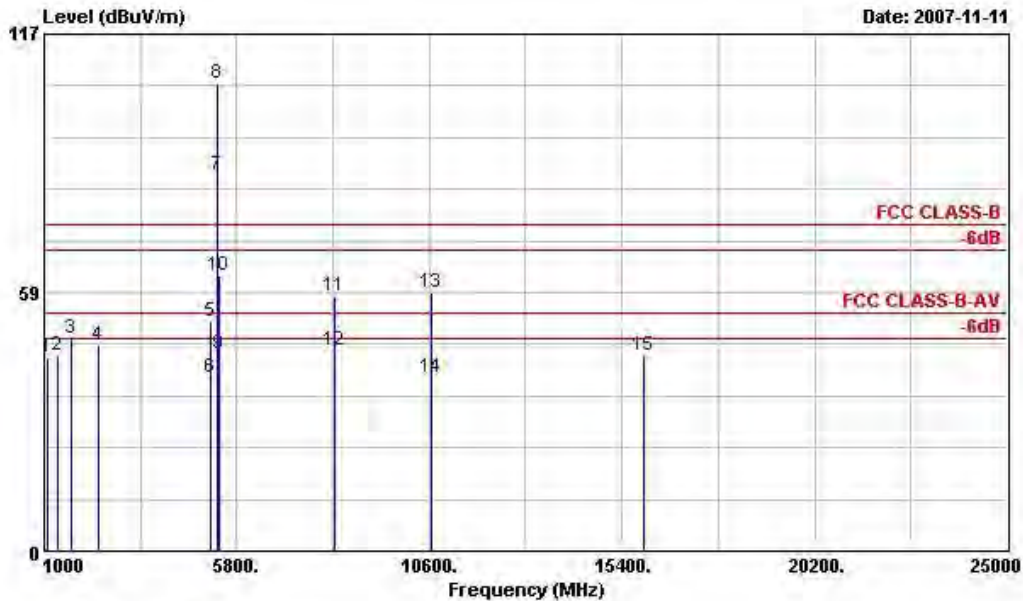

Site : 03CH04-HY
 Condition: FCC CLASS-B 3m HF-ANT-10094 VERTICAL
 EUT : N/B
 POWER : 120Wac/60Hz
 MODEL : FR 701819
 MEMO : 11n(a) Tx(20M)_CH64;5320MHz
 Data Rate:48

	Freq	Level	Over Limit	Limit Line	ReadAntenna	Cable	Preamp	Ant	Table	
	MHz	dBuV/m	dB	dBuV/m	dBuV	dB/m	dB	dB	cm	deg
1	1084.000	43.72	-30.28	74.00	50.22	25.46	2.34	34.30	100	0 Peak
2	1326.000	44.35	-29.65	74.00	49.22	26.48	2.60	33.95	100	0 Peak
3	1668.000	47.94	-26.06	74.00	50.20	28.47	2.97	33.70	100	0 Peak
4	2340.000	46.67	-27.33	74.00	46.23	30.52	3.69	33.77	100	0 Peak
5	5150.000	51.78	-22.22	74.00	44.74	35.28	6.00	34.24	100	0 Peak
6	5150.000	39.24	-14.76	54.00	32.20	35.28	6.00	34.24	112	9 Average
7 @	5320.000	84.89			77.58	35.48	6.00	34.17	112	9 Average
8 @	5320.000	105.87			98.56	35.48	6.00	34.17	100	0 Peak
9	5350.000	44.55	-9.45	54.00	37.18	35.52	6.00	34.15	112	9 Average
10	5350.000	62.31	-11.69	74.00	54.94	35.52	6.00	34.15	100	0 Peak
11	8236.000	57.66	-16.34	74.00	45.25	39.50	6.88	33.98	100	0 Peak
12	8236.000	45.52	-8.48	54.00	33.11	39.50	6.88	33.98	100	114 Average
13	10638.000	58.54	-15.46	74.00	93.60	-8.44	7.80	34.42	100	0 Peak
14	10638.000	39.40	-14.60	54.00	74.46	-8.44	7.80	34.42	100	131 Average
15	15954.000	44.25	-29.75	74.00	74.59	-4.25	8.77	34.86	100	0 Peak

Remark: #7 and #8 Fundamental Signal

Remark: Frequency from 25GHz to 40GHz, the emission emitted by the EUT is too low to be measured.



- Test Mode : Mode 13
- Polarization : Horizontal

The test that passed at minimum margin was marked by the boldface in the following table.

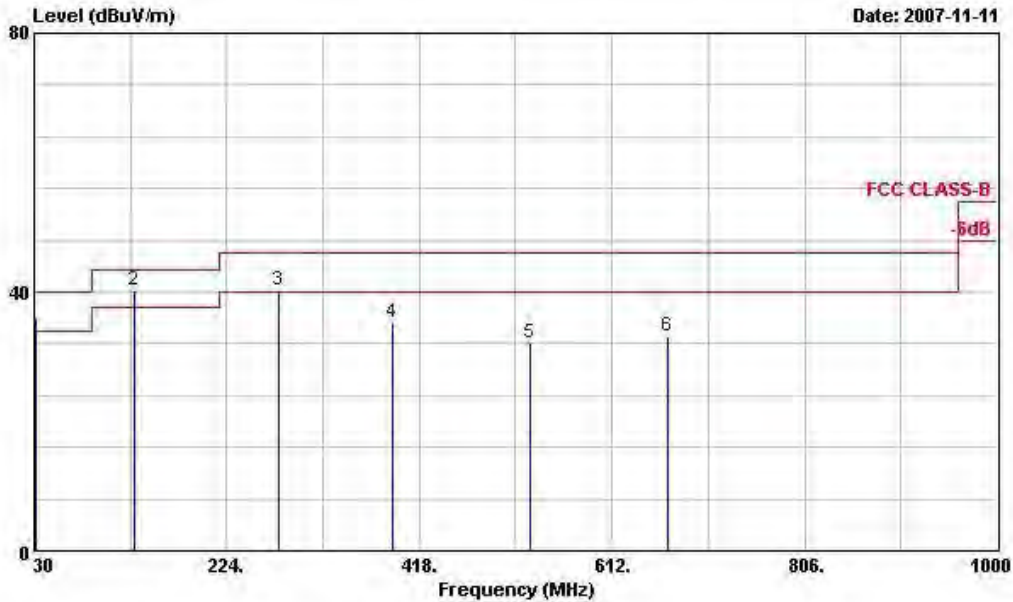

Site : 03CH04-HY
 Condition: FCC CLASS-B 3m ANT2724 HORIZONTAL
 EUT : N/B
 POWER : 120Vac/60Hz
 MODEL : FR 701819
 MEMO : 11n(a) Tx(40M)_CH38;5190MHz
 Data Rate: 9

	Freq	Level	Over Limit	Limit Line	ReadAntenna Level	Antenna Factor	Cable Loss	Preamp Factor	Ant Pos	Table Pos	Remark
	MHz	dBuV/m	dB	dBuV/m	dBuV	dB/m	dB	dB	cm	deg	
1	31.890	36.02	-3.98	40.00	47.05	16.34	0.89	28.26	---	---	Peak
2	131.250	40.27	-3.23	43.50	55.41	11.37	1.56	28.08	100	197	Peak
3	275.970	40.21	-5.79	46.00	53.27	12.43	2.15	27.65	---	---	Peak
4	391.000	35.24	-10.76	46.00	45.48	15.45	2.54	28.24	---	---	Peak
5	528.900	32.14	-13.86	46.00	40.49	17.75	2.92	29.03	---	---	Peak
6	668.200	33.07	-12.93	46.00	38.66	20.06	3.45	29.10	---	---	Peak

Remark: Frequency from 9KHz to 30MHz, the emission emitted by the EUT is too low to be measured.

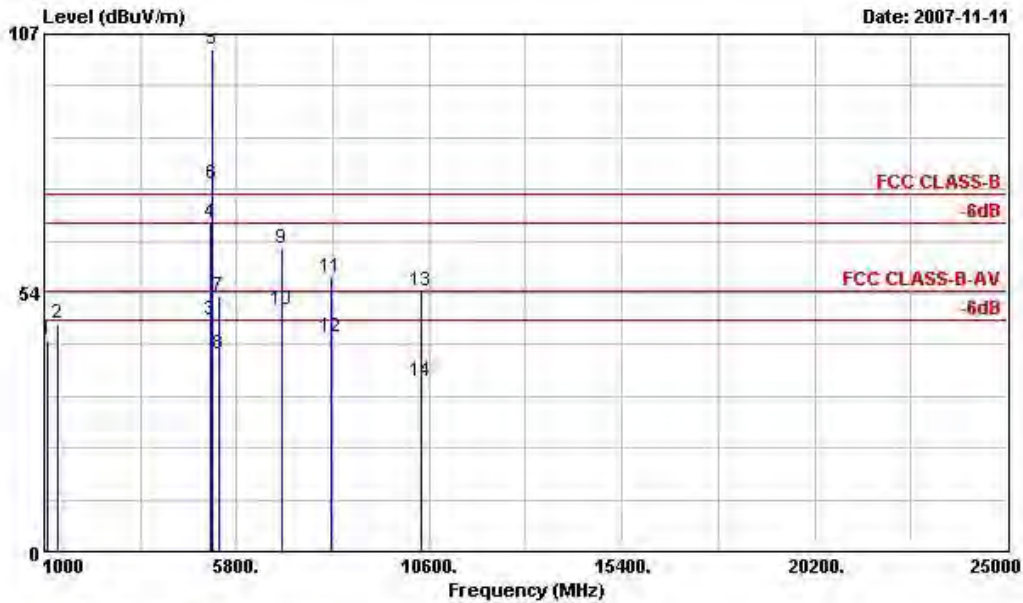

Site : 03CH04-HY
 Condition: FCC CLASS-B 3m HF-ANT-10094 HORIZONTAL
 EUT : N/B
 POWER : 120Wac/60Hz
 MODEL : FR 701819
 MEMO : 11n(a) Tx(40M)_CH38;5190MHz
 Data Rate:9

	Freq	Level	Over Limit	Limit Line	ReadAntenna Level	Antenna Factor	Cable Loss	Preamp Factor	Ant Pos	Table Pos	Remark
	MHz	dBuV/m	dB	dBuV/m	dBuV	dB/m	dB	dB	cm	deg	
1	1094.000	43.66	-30.34	74.00	50.05	25.53	2.34	34.26	100	0	Peak
2	1332.000	47.03	-26.97	74.00	51.83	26.55	2.60	33.95	100	0	Peak
3	5150.000	47.83	-6.17	54.00	40.79	35.28	6.00	34.24	112	4	Average
4	5150.000	67.76	-6.24	74.00	60.72	35.28	6.00	34.24	100	0	Peak
5 @	5190.000	103.66			96.57	35.32	6.00	34.23	100	0	Peak
6 X	5190.000	76.01			68.92	35.32	6.00	34.23	112	4	Average
7	5350.000	52.85	-21.15	74.00	45.48	35.52	6.00	34.15	100	0	Peak
8	5350.000	40.67	-13.33	54.00	33.30	35.52	6.00	34.15	112	4	Average
9	6924.000	62.67	-11.33	74.00	50.15	38.75	6.34	32.56	100	0	Peak
10 !	6924.000	50.14	-3.86	54.00	37.62	38.75	6.34	32.56	100	320	Average
11	8150.000	56.82	-17.18	74.00	44.30	39.50	6.83	33.81	100	0	Peak
12	8150.000	44.29	-9.71	54.00	31.77	39.50	6.83	33.81	100	183	Average
13	10376.000	53.76	-20.24	74.00	89.28	-8.69	7.80	34.63	100	0	Peak
14	10376.000	35.12	-18.88	54.00	70.64	-8.69	7.80	34.63	100	32	Average

Remark: #5 and #6 Fundamental Signal

Remark: Frequency from 25GHz to 40GHz, the emission emitted by the EUT is too low to be measured.



• Polarization : Vertical

■ The test that passed at minimum margin was marked by the boldface in the following table.

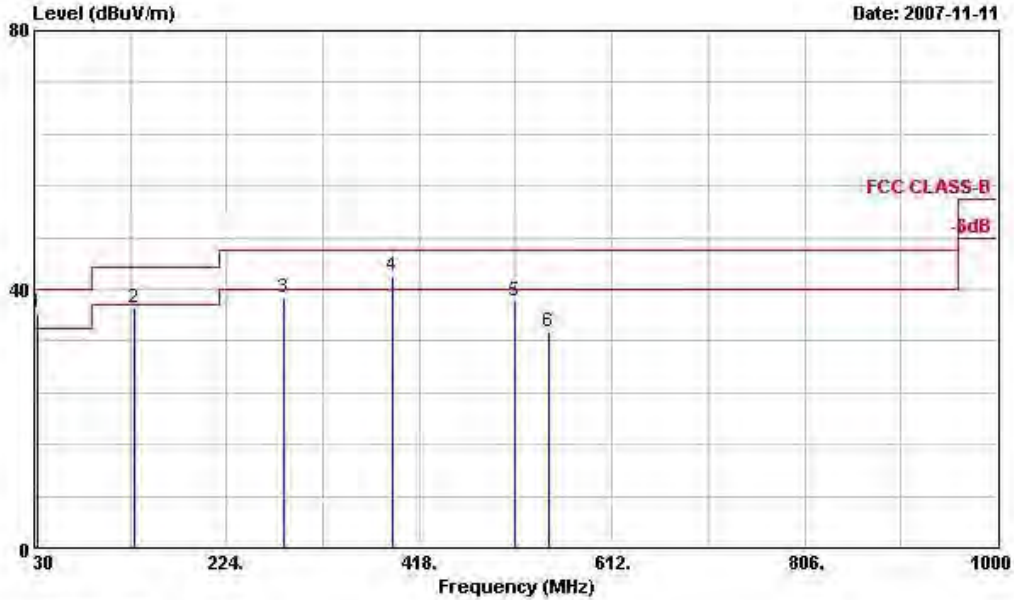

Site : 03CH04-HY
 Condition: FCC CLASS-B 3m ANT2724 VERTICAL
 EUT : N/B
 POWER : 120Vac/60Hz
 MODEL : FR 701819
 MEMO : 1ln(a) Tx(40M)_CH38;5190MHz
 Data Rate: 9

	Freq	Level	Over Limit	Limit Line	Read Level	Antenna Factor	Cable Loss	Preamp Factor	Ant Pos	Table Pos	Remark
	MHz	dBuV/m	dB	dBuV/m	dBuV	dB/m	dB	dB	cm	deg	
1	32.970	36.44	-3.56	40.00	47.48	16.33	0.90	28.26	100	188	Peak
2	131.250	37.13	-6.37	43.50	52.27	11.37	1.56	28.08	---	---	Peak
3	282.180	38.60	-7.40	46.00	51.66	12.40	2.17	27.64	---	---	Peak
4	391.000	42.17	-3.83	46.00	52.41	15.45	2.54	28.24	---	---	Peak
5	514.900	38.19	-7.81	46.00	46.99	17.35	2.87	29.01	---	---	Peak
6	547.800	33.43	-12.57	46.00	41.15	18.33	2.99	29.05	---	---	Peak

Remark: Frequency from 9KHz to 30MHz, the emission emitted by the EUT is too low to be measured.

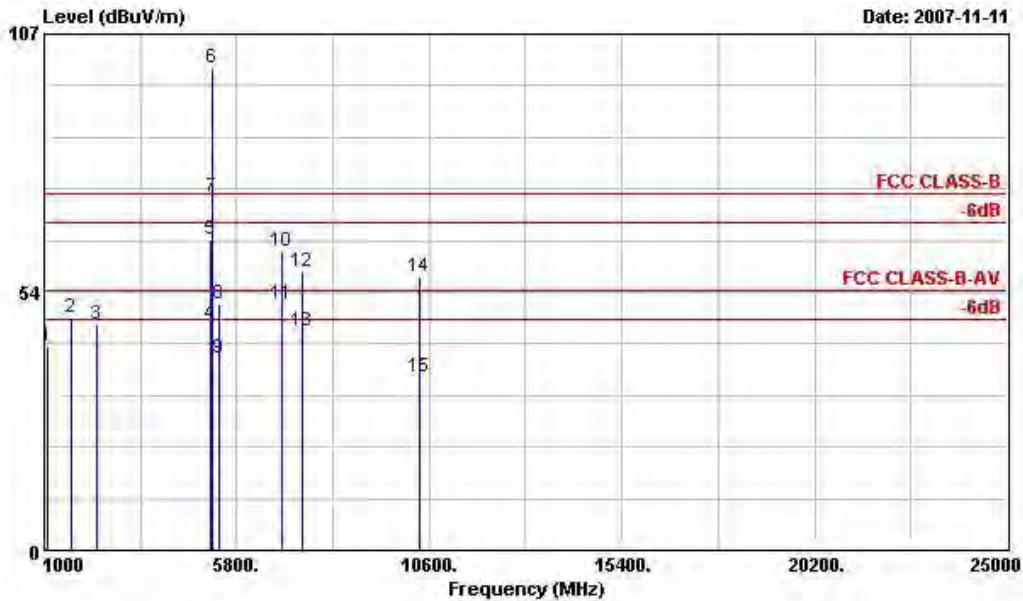

Site : 03CH04-HY
 Condition: FCC CLASS-B 3m HF-ANT-10094 VERTICAL
 EUT : N/B
 POWER : 120Wac/60Hz
 MODEL : FR 701819
 MEMO : 11n(a) Tx(40M)_CH38;5190MHz
 Data Rate:9

	Freq	Level	Over	Limit	ReadAntenna	Cable	Preamp	Ant	Table	
	MHz	dBuV/m	dB	dBuV/m	dBuV	dB	dB	cm	deg	Remark
1	1078.000	42.12	-31.88	74.00	48.64	25.46	2.31	34.30	100	0 Peak
2	1664.000	48.25	-25.75	74.00	50.51	28.47	2.97	33.70	100	0 Peak
3	2326.000	46.67	-27.33	74.00	46.23	30.54	3.66	33.77	100	0 Peak
4	5150.000	46.67	-7.33	54.00	39.63	35.28	6.00	34.24	107	21 Average
5	5150.000	64.37	-9.63	74.00	57.33	35.28	6.00	34.24	100	0 Peak
6 @	5190.000	100.03			92.94	35.32	6.00	34.23	100	0 Peak
7 X	5190.000	73.36			66.27	35.32	6.00	34.23	107	21 Average
8	5350.000	51.14	-22.86	74.00	43.77	35.52	6.00	34.15	100	0 Peak
9	5350.000	39.62	-14.38	54.00	32.25	35.52	6.00	34.15	107	21 Average
10	6924.000	62.12	-11.88	74.00	49.60	38.75	6.34	32.56	100	0 Peak
11	6924.000	51.14	-2.86	54.00	38.62	38.75	6.34	32.56	100	155 Average
12	7420.000	57.64	-16.36	74.00	45.34	39.37	6.53	33.61	100	0 Peak
13	7420.000	45.34	-8.66	54.00	33.04	39.37	6.53	33.61	100	278 Average
14	10374.000	56.78	-17.22	74.00	92.32	-8.71	7.80	34.63	100	0 Peak
15	10374.000	35.87	-18.13	54.00	71.41	-8.71	7.80	34.63	100	271 Average

Remark: #6 and #7 Fundamental Signal

Remark: Frequency from 25GHz to 40GHz, the emission emitted by the EUT is too low to be measured.



- Test Mode : Mode 14
- Polarization : Horizontal

The test that passed at minimum margin was marked by the boldface in the following table.

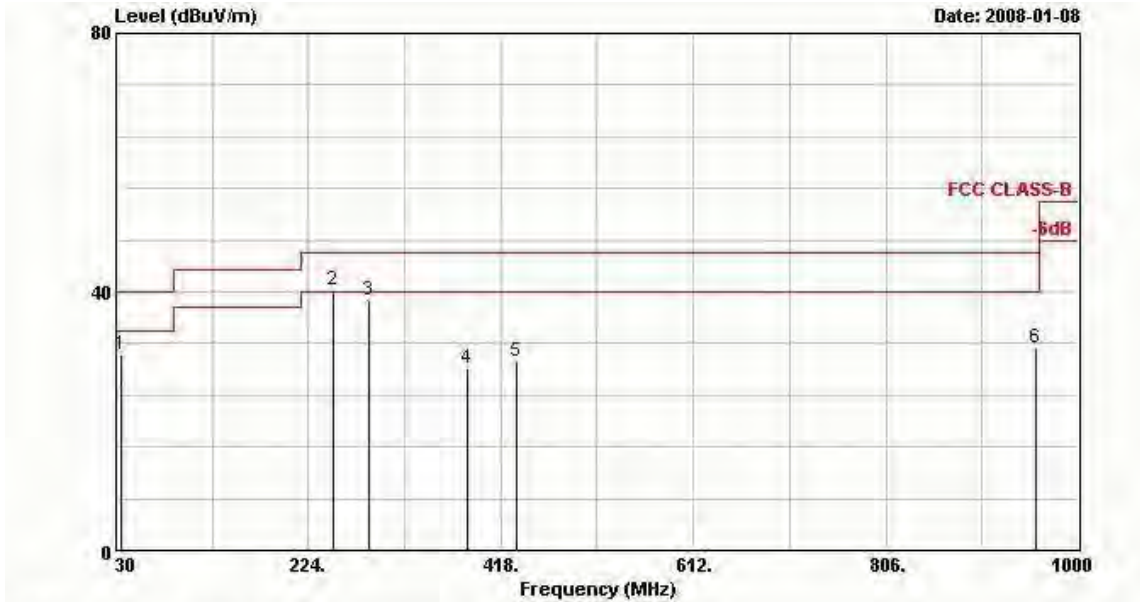

Site : 03CH04-HY
 Condition: FCC CLASS-B 3m ANT2724 HORIZONTAL
 EUT : N/B
 POWER : 120Vac/60Hz
 MODEL : FR 701819
 MEMO : 11n(a) Tx(40M)_CH46;5230MHz
 Data Rate: 9

	Freq	Level	Over Limit	Limit Line	ReadAntenna Level	Antenna Factor	Cable Loss	Preamp Factor	Ant Pos	Table Pos	Remark
	MHz	dBuV/m	dB	dBuV/m	dBuV	dB/m	dB	dB	cm	deg	
1	35.130	30.37	-9.63	40.00	41.65	16.29	0.69	28.26	---	---	Peak
2	248.970	40.16	-5.84	46.00	53.53	12.50	1.84	27.70	100	142	Peak
3	284.340	38.77	-7.23	46.00	52.02	12.39	1.99	27.63	---	---	Peak
4	383.300	28.20	-17.80	46.00	38.86	15.18	2.34	28.18	---	---	Peak
5	433.700	29.21	-16.79	46.00	39.11	16.14	2.49	28.54	---	---	Peak
6	957.300	31.36	-14.64	46.00	31.29	24.96	3.79	28.69	---	---	Peak

Remark: Frequency from 9KHz to 30MHz, the emission emitted by the EUT is too low to be measured.

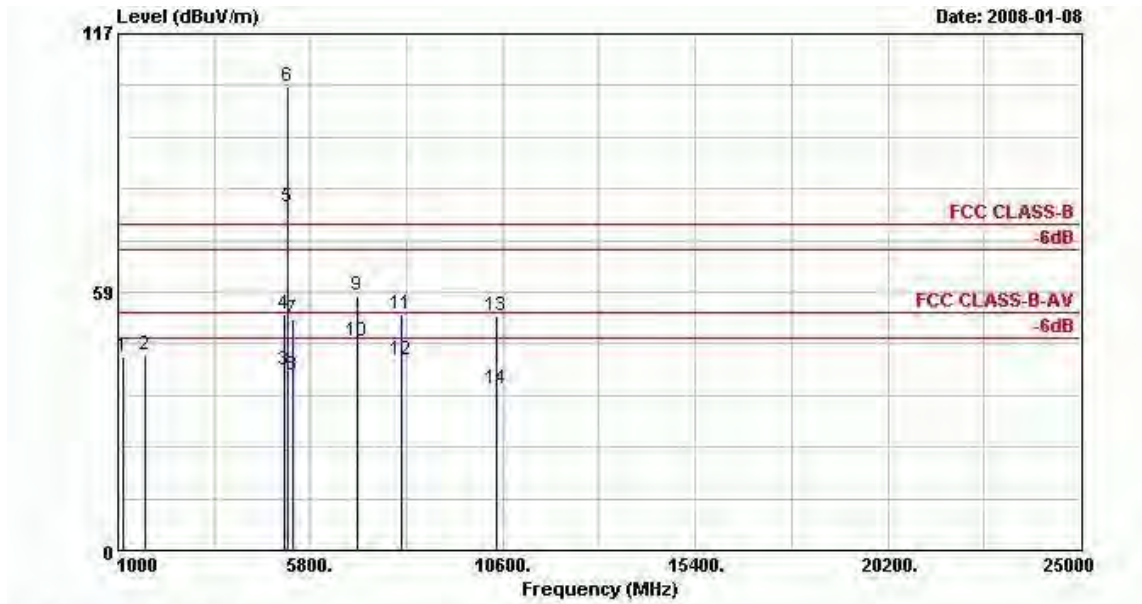

Site : 03CH04-HY
 Condition: FCC CLASS-B 3m HF-ANT-3117 HORIZONTAL
 EUT : N/B
 POWER : 120Vac/60Hz
 MODEL : FR 701819
 MEMO : 11n(a) Tx(40M)_CH46;5230MHz
 Data Rate: 9

	Freq	Level	Over	Limit	Read	Antenna	Cable	Preamp	Ant	Table	
	MHz	dBuV/m	dB	dBuV/m	Level	Factor	Loss	Factor	Pos	Pos	Remark
					dBV	dB/m	dB	dB	cm	deg	
1	1118.000	44.05	-29.95	74.00	47.52	28.40	2.36	34.23	100	0	Peak
2	1662.000	44.40	-29.60	74.00	45.23	29.90	2.97	33.70	100	0	Peak
3	5150.000	40.84	-13.16	54.00	34.19	34.89	6.00	34.24	107	2	Average
4	5150.000	53.58	-20.42	74.00	46.93	34.89	6.00	34.24	100	0	Peak
5 X	5230.000	77.67			70.94	34.94	6.00	34.21	107	2	Average
6 @	5230.000	105.02			98.29	34.94	6.00	34.21	100	0	Peak
7	5350.000	52.38	-21.62	74.00	45.52	35.01	6.00	34.15	100	0	Peak
8	5350.000	39.54	-14.46	54.00	32.68	35.01	6.00	34.15	107	2	Average
9	6974.000	57.80	-16.20	74.00	47.97	36.00	6.35	32.52	100	0	Peak
10	6974.000	47.31	-6.69	54.00	37.48	36.00	6.35	32.52	100	127	Average
11	8060.000	53.40	-20.60	74.00	44.09	36.21	6.78	33.68	100	0	Peak
12	8060.000	43.08	-10.92	54.00	33.77	36.21	6.78	33.68	100	130	Average
13	10458.000	53.22	-20.78	74.00	88.53	-8.56	7.80	34.55	100	0	Peak
14	10458.000	36.75	-17.25	54.00	72.06	-8.56	7.80	34.55	100	171	Average

Remark: #5 and #6 Fundamental Signal

Remark: Frequency from 25GHz to 40GHz, the emission emitted by the EUT is too low to be measured.



• Polarization : Vertical

■ The test that passed at minimum margin was marked by the boldface in the following table.

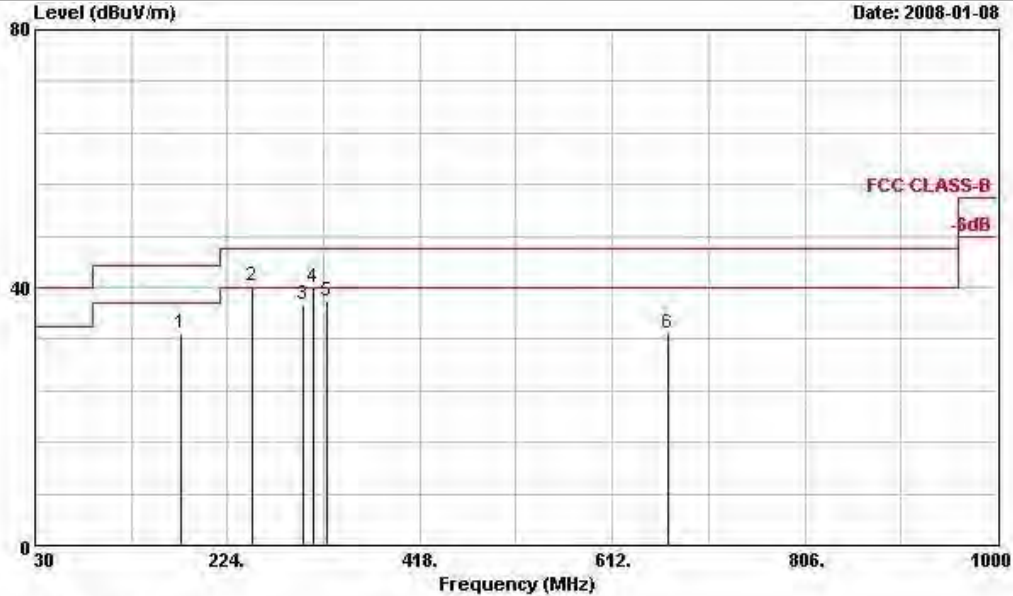

Site : 03CH04-HY
 Condition: FCC CLASS-B 3m ANT2724 VERTICAL
 EUT : N/B
 POWER : 120Vac/60Hz
 MODEL : FR 701819
 MEMO : 1ln(a) Tx(40M)_CH46;5230MHz
 Data Rate:9

	Freq	Level	Over	Limit	ReadAntenna	Cable	Preamp	Ant	Table		
	MHz	dBuV/m	dB	dBuV/m	dBuV	Loss	Factor	Pos	Pos	Remark	
					dB/m	dB	dB	cm	deg		
1	176.340	33.02	-10.48	43.50	50.72	8.61	1.59	27.90	---	---	Peak
2	248.970	40.32	-5.68	46.00	53.69	12.50	1.84	27.70	100	174	Peak
3	299.460	37.45	-8.55	46.00	50.69	12.31	2.05	27.60	---	---	Peak
4	310.500	39.92	-6.08	46.00	52.83	12.68	2.09	27.68	---	---	Peak
5	324.500	37.91	-8.09	46.00	50.37	13.18	2.14	27.77	---	---	Peak
6	668.200	33.02	-12.98	46.00	38.89	20.06	3.17	29.10	---	---	Peak

Remark: Frequency from 9KHz to 30MHz, the emission emitted by the EUT is too low to be measured.

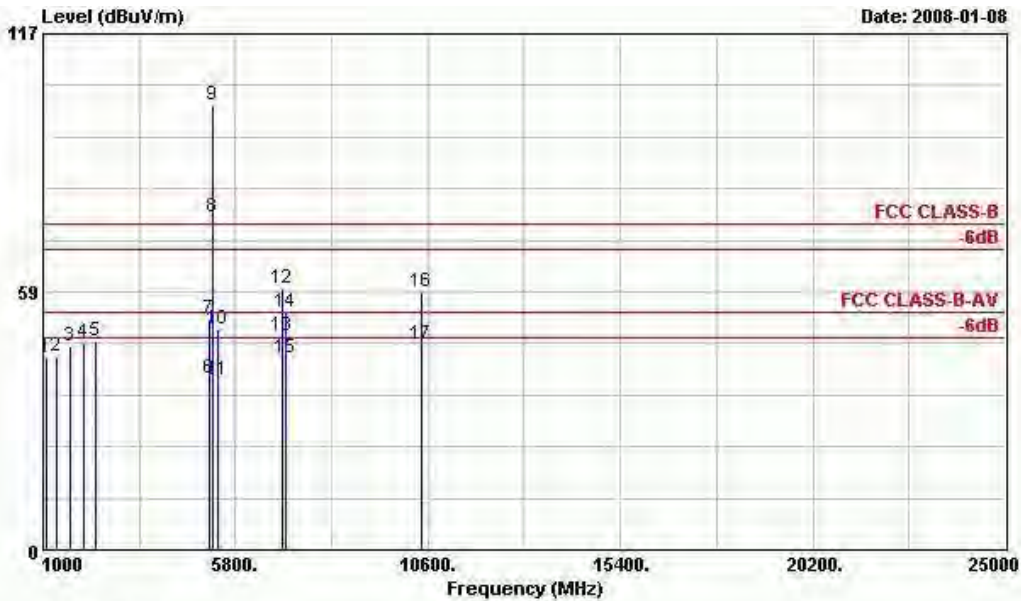

Site : 03CH04-HY
 Condition: FCC CLASS-B 3m HF-ANT-3117 VERTICAL
 EUT : N/B
 POWER : 120Vac/60Hz
 MODEL : FR 701819
 MEMO : 1ln(a) Tx(40M)_CH46;5230MHz
 Data Rate: 9

	Freq	Level	Over	Limit	Read	Antenna	Cable	Preamp	Ant	Table	
	MHz	dBuV/m	dB	dBuV/m	dBuV	dB/m	dB	dB	cm	deg	Remark
1	1100.000	43.43	-30.57	74.00	46.97	28.38	2.34	34.26	100	0	Peak
2	1332.000	44.05	-29.95	74.00	46.82	28.58	2.60	33.95	100	0	Peak
3	1668.000	46.33	-27.67	74.00	47.16	29.90	2.97	33.70	100	0	Peak
4	2004.000	46.87	-27.13	74.00	44.93	32.30	3.34	33.70	100	0	Peak
5	2332.000	47.17	-26.83	74.00	44.75	32.50	3.69	33.77	100	0	Peak
6	5150.000	38.98	-15.02	54.00	32.33	34.89	6.00	34.24	121	7	Average
7	5150.000	52.46	-21.54	74.00	45.81	34.89	6.00	34.24	100	0	Peak
8 X	5230.000	75.24			68.51	34.94	6.00	34.21	121	7	Average
9 @	5230.000	100.70			93.97	34.94	6.00	34.21	100	0	Peak
10	5350.000	50.11	-23.89	74.00	43.25	35.01	6.00	34.15	100	0	Peak
11	5350.000	38.30	-15.70	54.00	31.44	35.01	6.00	34.15	121	7	Average
12	6974.000	59.18	-14.82	74.00	49.35	36.00	6.35	32.52	100	0	Peak
13	6974.000	48.34	-5.66	54.00	38.51	36.00	6.35	32.52	100	135	Average
14	7036.000	54.07	-19.93	74.00	44.32	36.00	6.38	32.63	100	0	Peak
15	7036.000	43.32	-10.68	54.00	33.57	36.00	6.38	32.63	100	158	Average
16	10458.000	58.54	-15.46	74.00	93.85	-8.56	7.80	34.55	100	0	Peak
17	10458.000	46.68	-7.32	54.00	81.99	-8.56	7.80	34.55	100	187	Average

Remark: #8 and #9 Fundamental Signal

Remark: Frequency from 25GHz to 40GHz, the emission emitted by the EUT is too low to be measured.



- Test Mode : Mode 15
- Polarization : Horizontal

The test that passed at minimum margin was marked by the boldface in the following table.

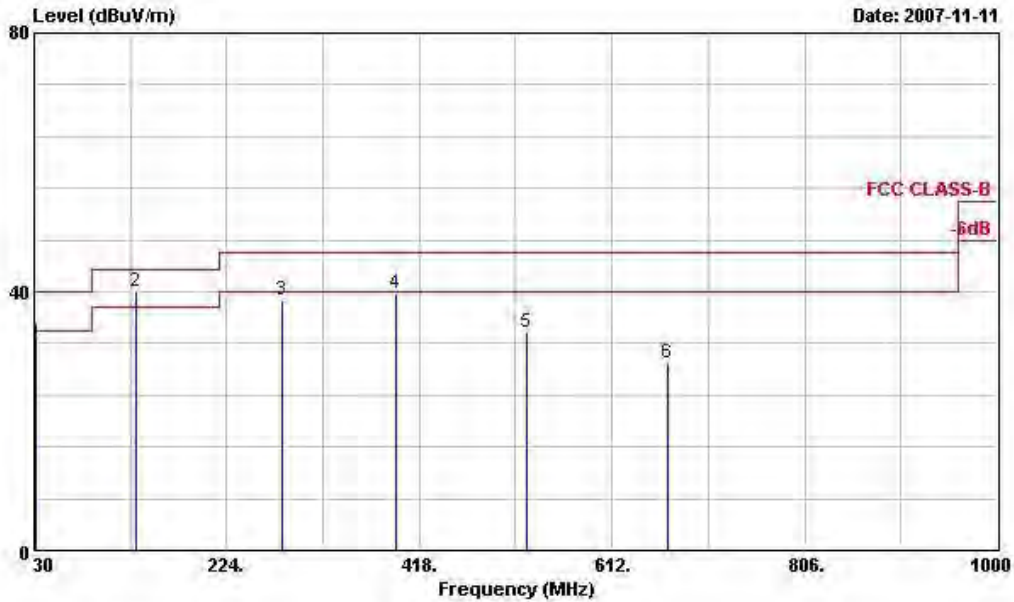

Site : 03CH04-HY
 Condition: FCC CLASS-B 3m ANT2724 HORIZONTAL
 EUT : N/B
 POWER : 120Vac/60Hz
 MODEL : FR 701819
 MEMO : 11n(a) Tx(40M)_CH54;5270MHz
 Data Rate: 9

	Freq	Level	Over Limit	Limit	ReadAntenna	Cable	Preamp	Ant	Table	Remark	
	MHz	dBuV/m	dB	dBuV/m	dBuV	dB	dB	cm	deg		
1	31.620	35.36	-4.64	40.00	46.40	16.34	0.88	28.26	---	---	Peak
2	133.410	39.96	-3.54	43.50	55.34	11.11	1.58	28.07	100	203	Peak
3	280.020	38.71	-7.29	46.00	51.77	12.41	2.17	27.64	---	---	Peak
4	394.500	39.74	-6.26	46.00	49.86	15.58	2.56	28.26	---	---	Peak
5	526.100	33.71	-12.29	46.00	42.16	17.66	2.91	29.03	---	---	Peak
6	668.200	29.05	-16.95	46.00	34.64	20.06	3.45	29.10	---	---	Peak

Remark: Frequency from 9KHz to 30MHz, the emission emitted by the EUT is too low to be measured.

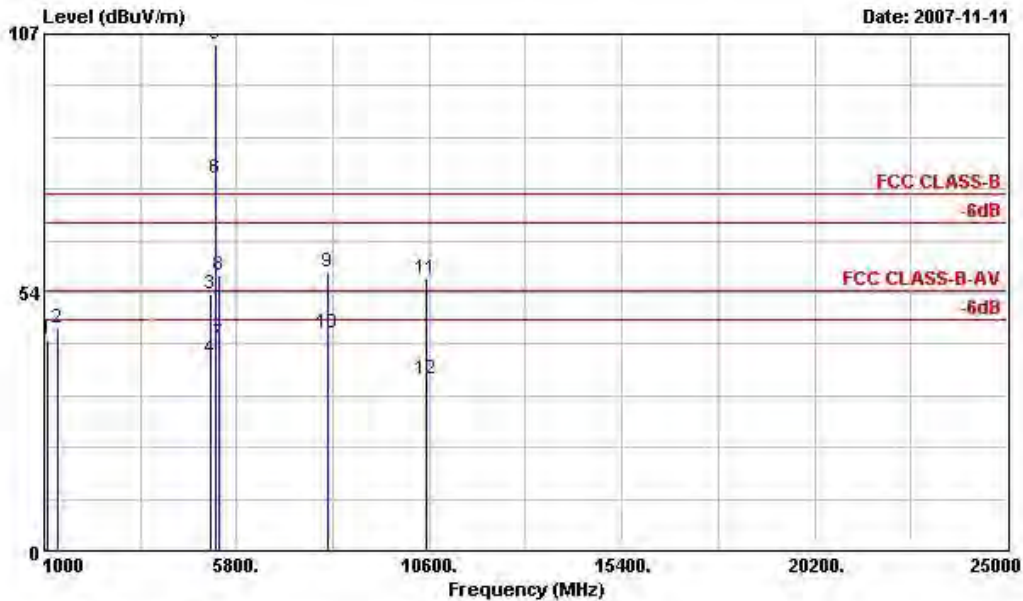

Date: 2007-11-11

Site : 03CH04-HY
 Condition: FCC CLASS-B 3m HF-ANT-10094 HORIZONTAL
 EUT : N/B
 POWER : 120Wac/60Hz
 MODEL : FR 701819
 MEMO : 11ln(a) Tx(40M)_CH54;5270MHz
 Data Rate: 9

	Freq	Level	Over Limit	Limit Line	ReadAntenna Level	Antenna Factor	Cable Loss	Preamp Factor	Ant Pos	Table Pos	Remark
	MHz	dBuV/m	dB	dBuV/m	dBuV	dB/m	dB	dB	cm	deg	
1	1100.000	43.66	-30.34	74.00	50.05	25.53	2.34	34.26	100	0	Peak
2	1334.000	46.15	-27.85	74.00	50.95	26.55	2.60	33.95	100	0	Peak
3	5150.000	53.13	-20.87	74.00	46.09	35.28	6.00	34.24	100	0	Peak
4	5150.000	39.78	-14.22	54.00	32.74	35.28	6.00	34.24	100	2	Average
5 @	5270.000	104.92			97.69	35.42	6.00	34.19	100	0	Peak
6 X	5270.000	77.00			69.77	35.42	6.00	34.19	100	2	Average
7	5350.000	42.78	-11.22	54.00	35.41	35.52	6.00	34.15	100	2	Average
8	5350.000	56.99	-17.01	74.00	49.62	35.52	6.00	34.15	100	0	Peak
9	8076.000	57.76	-16.24	74.00	45.15	39.50	6.80	33.68	100	0	Peak
10	8076.000	45.14	-8.86	54.00	32.53	39.50	6.80	33.68	100	244	Average
11	10542.000	56.19	-17.81	74.00	91.36	-8.48	7.80	34.48	100	0	Peak
12	10542.000	35.54	-18.46	54.00	70.71	-8.48	7.80	34.48	100	278	Average

Remark: #5 and #6 Fundamental Signal

Remark: Frequency from 25GHz to 40GHz, the emission emitted by the EUT is too low to be measured.



• Polarization : Vertical

■ The test that passed at minimum margin was marked by the boldface in the following table.

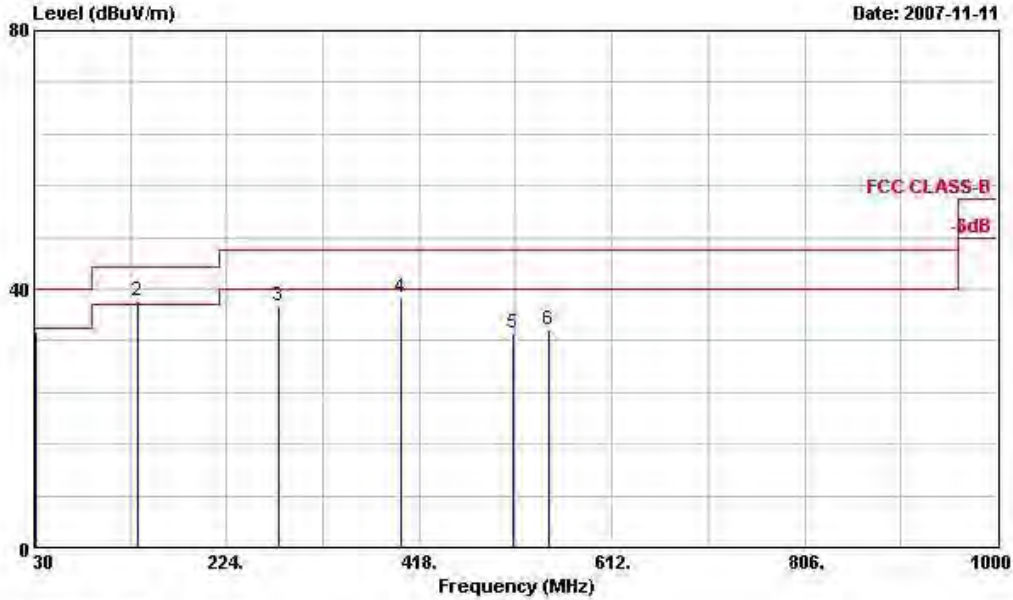

Site : 03CH04-HY
 Condition: FCC CLASS-B 3m ANT2724 VERTICAL
 EUT : N/E
 POWER : 120Vac/60Hz
 MODEL : FR 701819
 MEMO : 1ln(a) Tx(40M)_CH54;5270MHz
 Data Rate:9

	Freq	Level	Over Limit	Limit Line	Read Level	Antenna Factor	Cable Loss	Preamp Factor	Ant Pos	Table Pos	Remark
	MHz	dBuV/m	dB	dBuV/m	dBuV	dE/m	dB	dB	cm	deg	
1	31.890	33.41	-6.59	40.00	44.44	16.34	0.89	28.26	---	---	Peak
2	134.220	38.18	-5.32	43.50	53.55	11.11	1.59	28.07	100	171	Peak
3	277.050	37.33	-8.67	46.00	50.39	12.43	2.15	27.65	---	---	Peak
4	399.400	38.60	-7.40	46.00	48.57	15.75	2.57	28.29	---	---	Peak
5	512.100	33.17	-12.83	46.00	42.07	17.26	2.86	29.01	---	---	Peak
6	548.500	33.78	-12.22	46.00	41.47	18.36	3.00	29.05	---	---	Peak

Remark: Frequency from 9KHz to 30MHz, the emission emitted by the EUT is too low to be measured.

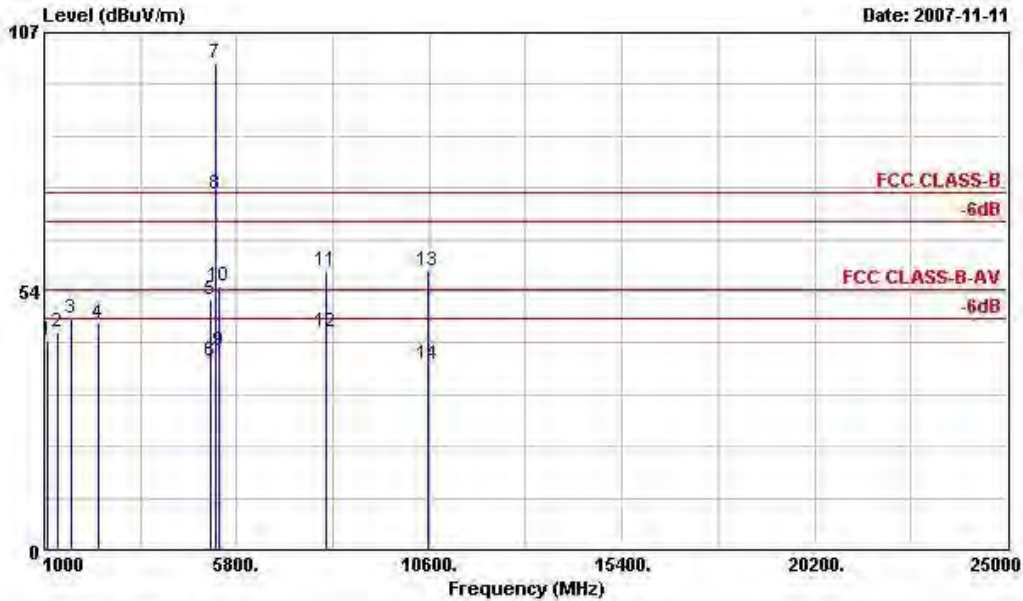

Site : 03CH04-HY
 Condition: FCC CLASS-B 3m HF-ANT-10094 VERTICAL
 EUT : N/E
 POWER : 120Vac/60Hz
 MODEL : FR 701819
 MEMO : 1ln(a) Tx(40M)_CH54;5270MHz
 Data Rate: 9

	Freq	Level	Over Limit	Limit Line	ReadAntenna Level	Antenna Factor	Cable Loss	Preamp Factor	Ant Pos	Table Pos	Remark
	MHz	dBuV/m	dB	dBuV/m	dBuV	dB/m	dB	dB	cm	deg	
1	1084.000	43.41	-30.59	74.00	49.91	25.46	2.34	34.30	100	0	Peak
2	1332.000	45.00	-29.00	74.00	49.80	26.55	2.60	33.95	100	0	Peak
3	1668.000	47.79	-26.21	74.00	50.05	28.47	2.97	33.70	100	0	Peak
4	2334.000	46.83	-27.17	74.00	46.37	30.54	3.69	33.77	100	0	Peak
5	5150.000	51.61	-22.39	74.00	44.57	35.28	6.00	34.24	100	0	Peak
6	5150.000	39.23	-14.77	54.00	32.19	35.28	6.00	34.24	110	43	Average
7 @	5270.000	100.60			93.37	35.42	6.00	34.19	100	0	Peak
8 X	5270.000	73.71			66.48	35.42	6.00	34.19	110	43	Average
9	5350.000	41.14	-12.86	54.00	33.77	35.52	6.00	34.15	110	43	Average
10	5350.000	54.44	-19.56	74.00	47.07	35.52	6.00	34.15	100	0	Peak
11	8030.000	57.83	-16.17	74.00	45.20	39.50	6.77	33.64	100	0	Peak
12	8030.000	45.19	-8.81	54.00	32.56	39.50	6.77	33.64	100	127	Average
13	10545.000	57.67	-16.33	74.00	92.84	-8.48	7.80	34.48	100	0	Peak
14	10545.000	38.41	-15.59	54.00	73.58	-8.48	7.80	34.48	100	57	Average

Remark: #7 and #8 Fundamental Signal

Remark: Frequency from 25GHz to 40GHz, the emission emitted by the EUT is too low to be measured.



- Test Mode : Mode 16
- Polarization : Horizontal

The test that passed at minimum margin was marked by the boldface in the following table.

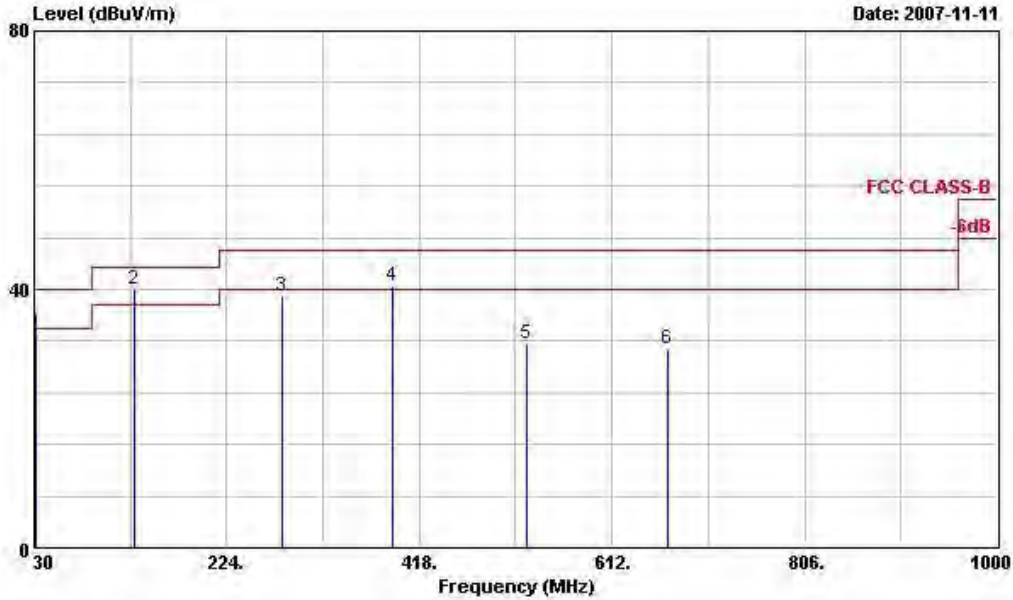

Site : 03CH04-HY
 Condition: FCC CLASS-B 3m ANT2724 HORIZONTAL
 EUT : N/B
 POWER : 120Vac/60Hz
 MODEL : FR 701819
 MEMO : 11n(a) Tx(40M)_CH62;5310MHz
 Data Rate: 9

	Freq	Level	Over Limit	Limit Line	ReadAntenna Level	Antenna Factor	Cable Loss	Preamp Factor	Ant Pos	Table Pos	Remark
	MHz	dBuV/m	dB	dBuV/m	dBuV	dB/m	dB	dB	cm	deg	
1	31.890	36.38	-3.62	40.00	47.41	16.34	0.89	28.26	---	---	Peak
2	131.250	39.89	-3.61	43.50	55.03	11.37	1.56	28.08	100	185	Peak
3	279.210	38.84	-7.16	46.00	51.90	12.42	2.16	27.64	---	---	Peak
4	391.000	40.59	-5.41	46.00	50.83	15.45	2.54	28.24	---	---	Peak
5	526.100	31.49	-14.51	46.00	39.94	17.66	2.91	29.03	---	---	Peak
6	668.200	30.67	-15.33	46.00	36.26	20.06	3.45	29.10	---	---	Peak

Remark: Frequency from 9KHz to 30MHz, the emission emitted by the EUT is too low to be measured.

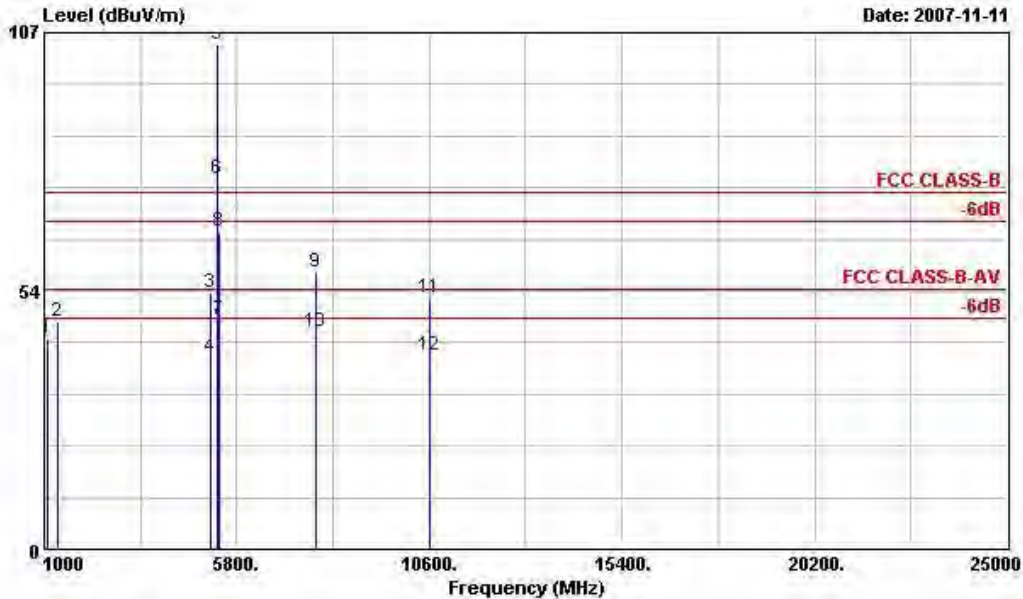

Site : 03CH04-HY
 Condition: FCC CLASS-B 3m HF-ANT-10094 HORIZONTAL
 EUT : N/E
 POWER : 120Vac/60Hz
 MODEL : FR 701819
 MEMO : 11n(a) Tx(40M)_CH62;5310MHz
 Data Rate: 9

	Freq	Level	Over Limit	Limit Line	ReadAntenna Level	Antenna Factor	Cable Loss	Preamp Factor	Ant Pos	Table Pos	Remark
	MHz	dBuV/m	dB	dBuV/m	dBuV	dB/m	dB	dB	cm	deg	
1	1084.000	43.53	-30.47	74.00	50.03	25.46	2.34	34.30	100	0	Peak
2	1334.000	47.18	-26.82	74.00	51.98	26.55	2.60	33.95	100	0	Peak
3	5150.000	53.09	-20.91	74.00	46.05	35.28	6.00	34.24	100	0	Peak
4	5150.000	39.72	-14.28	54.00	32.68	35.28	6.00	34.24	100	5	Average
5 @	5310.000	104.66			97.35	35.48	6.00	34.17	100	0	Peak
6 X	5310.000	76.74			69.43	35.48	6.00	34.17	100	5	Average
7	5350.000	47.69	-6.31	54.00	40.32	35.52	6.00	34.15	100	5	Average
8	5350.000	65.69	-8.31	74.00	58.32	35.52	6.00	34.15	100	0	Peak
9	7790.000	57.46	-16.54	74.00	45.02	39.46	6.67	33.69	100	0	Peak
10	7790.000	45.10	-8.90	54.00	32.66	39.46	6.67	33.69	100	187	Average
11	10626.000	51.92	-22.08	74.00	87.00	-8.45	7.80	34.44	100	0	Peak
12	10626.000	40.14	-13.86	54.00	75.22	-8.45	7.80	34.44	100	175	Average

Remark: #5 and #6 Fundamental Signal

Remark: Frequency from 25GHz to 40GHz, the emission emitted by the EUT is too low to be measured.



• Polarization : Vertical

■ The test that passed at minimum margin was marked by the boldface in the following table.

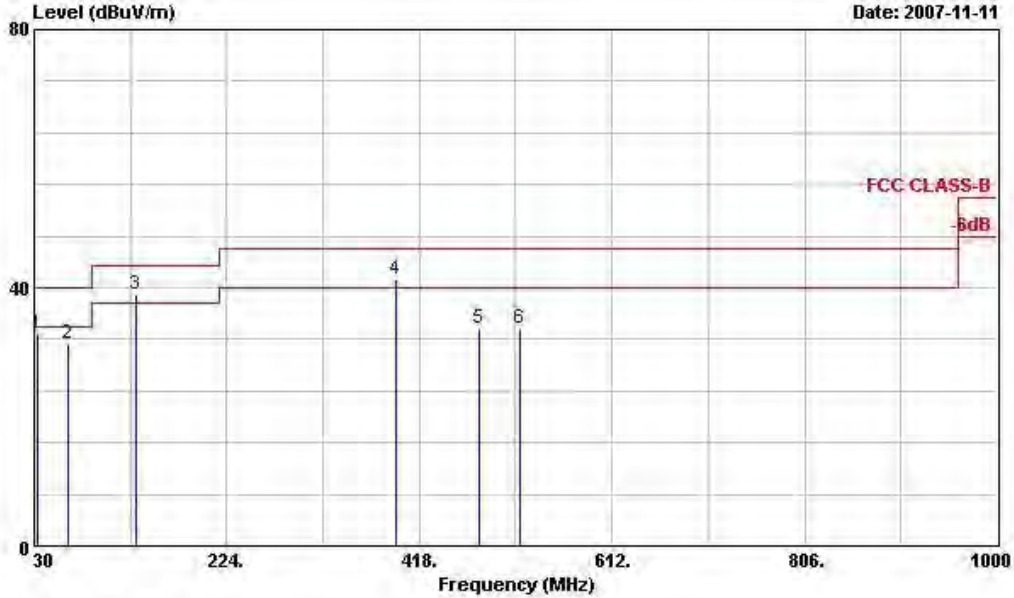

Site : 03CH04-HY
 Condition: FCC CLASS-B 3m ANT2724 VERTICAL
 EUT : N/B
 POWER : 120Vac/60Hz
 MODEL : FR 701819
 MEMO : 11n(a) Tx(40M)_CH62;5310MHz
 Data Rate:9

	Freq	Level	Over Limit	Limit Line	ReadAntenna Level	Antenna Factor	Cable Loss	Preamp Factor	Ant Pos	Table Pos	Remark
	MHz	dBuV/m	dB	dBuV/m	dBuV	dB/m	dB	dB	cm	deg	
1	32.970	33.02	-6.98	40.00	44.06	16.33	0.90	28.26	---	---	Peak
2	64.290	31.21	-8.79	40.00	54.05	4.29	1.14	28.27	---	---	Peak
3	133.410	38.82	-4.68	43.50	54.20	11.11	1.58	28.07	100	187	Peak
4	394.500	41.30	-4.70	46.00	51.42	15.58	2.56	28.26	---	---	Peak
5	478.500	33.62	-12.38	46.00	43.04	16.65	2.77	28.85	---	---	Peak
6	519.800	33.75	-12.25	46.00	42.39	17.49	2.89	29.02	---	---	Peak

Remark: Frequency from 9KHz to 30MHz, the emission emitted by the EUT is too low to be measured.

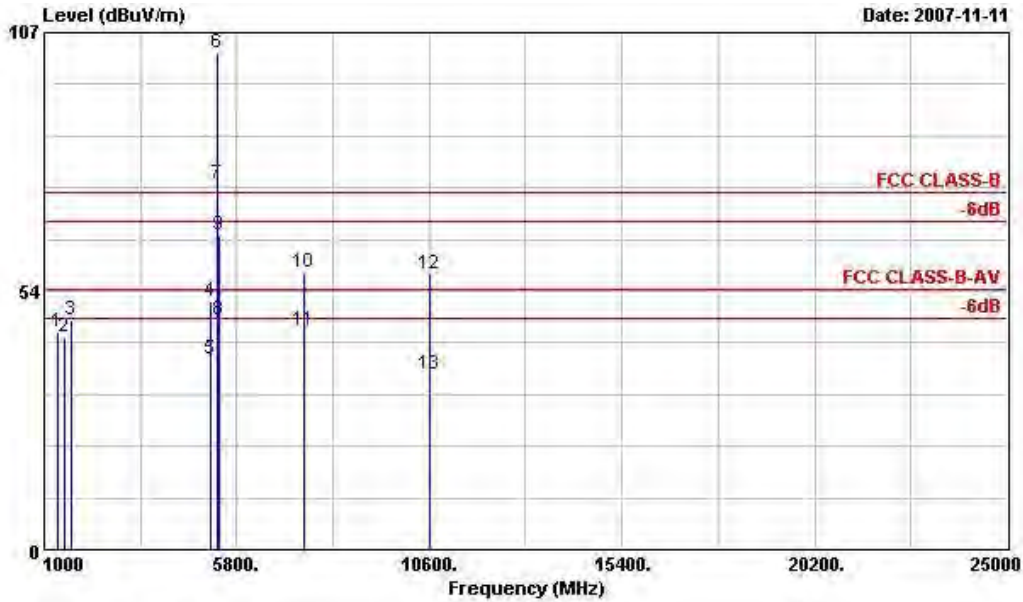

Site : 03CH04-HY
 Condition: FCC CLASS-B 3m HF-ANT-10094 VERTICAL
 EUT : N/B
 POWER : 120Vac/60Hz
 MODEL : FR 701819
 MEMO : 11n(a) Tx(40M)_CH62;5310MHz
 Data Rate:9

	Freq	Level	Over	Limit	ReadAntenna	Cable	Preamp	Ant	Table	
	MHz	dBuV/m	dB	dBuV/m	dBuV	dB	dB	cm	deg	Remark
1	1326.000	45.07	-28.93	74.00	49.94	26.48	2.60	33.95	100	0 Peak
2	1500.000	44.02	-29.98	74.00	47.74	27.20	2.79	33.70	100	0 Peak
3	1668.000	47.60	-26.40	74.00	49.86	28.47	2.97	33.70	100	0 Peak
4	5150.000	51.25	-22.75	74.00	44.21	35.28	6.00	34.24	100	0 Peak
5	5150.000	39.26	-14.74	54.00	32.22	35.28	6.00	34.24	112	10 Average
6 @	5310.000	102.86			95.55	35.48	6.00	34.17	100	0 Peak
7 X	5310.000	75.62			68.31	35.48	6.00	34.17	112	10 Average
8	5350.000	47.56	-6.44	54.00	40.19	35.52	6.00	34.15	112	10 Average
9	5350.000	65.15	-8.85	74.00	57.78	35.52	6.00	34.15	100	0 Peak
10	7470.000	57.47	-16.53	74.00	45.26	39.39	6.55	33.74	100	0 Peak
11	7470.000	45.26	-8.74	54.00	33.05	39.39	6.55	33.74	100	245 Average
12	10614.000	56.93	-17.07	74.00	92.02	-8.46	7.80	34.44	100	0 Peak
13	10614.000	36.21	-17.79	54.00	71.30	-8.46	7.80	34.44	100	145 Average

Remark: #6 and #7 Fundamental Signal

Remark: Frequency from 25GHz to 40GHz, the emission emitted by the EUT is too low to be measured.



5.6.4 E.I.R.P. Power

Mode	Frequency (MHz)	Field Strength (dBuV/m)	EIRP (dBm)	Over Limit (dB)	Limit (dBm)
802.11a	5150.00 MHz	61.60 dBuV/m	-35.53	-8.53	-27.00
	5350.00 MHz	56.80 dBuV/m	-40.33	-13.33	-27.00
802.11n(a) BW 20M	5150.00 MHz	64.26 dBuV/m	-32.87	-5.87	-27.00
	5350.00 MHz	62.31 dBuV/m	-34.82	-7.82	-27.00
802.11n(a) BW 40M	5150.00 MHz	67.76 dBuV/m	-29.37	-2.37	-27.00
	5350.00 MHz	65.69 dBuV/m	-31.44	-4.44	-27.00

Remark: $EIRP = 10 * \text{Log}(\{10^{[(\text{Field Strength} - 120) / 20]} * \text{distance}\}^2 / \{30 * [10^{(\text{Antenna Gain} / 10)}] / 0.001\})$



5.7 Band Edges Measurement

5.7.1 Measuring Instruments

As described in chapter 6 of this test report.

5.7.2 Test Procedure

1. Set both RBW and VBW of spectrum analyzer to 1MHz with convenient frequency span including 1MHz bandwidth from band edge.
2. The band edges was measured and recorded.

5.7.3 Test Result

- Temperature : 25~26°C
- Relative Humidity : 49~51%
- Test Engineer : CKC

Test Result Mode	Verdict
Test Result for 802.11a band I,II :	PASS



5.7.4 Test Data

Mode 1

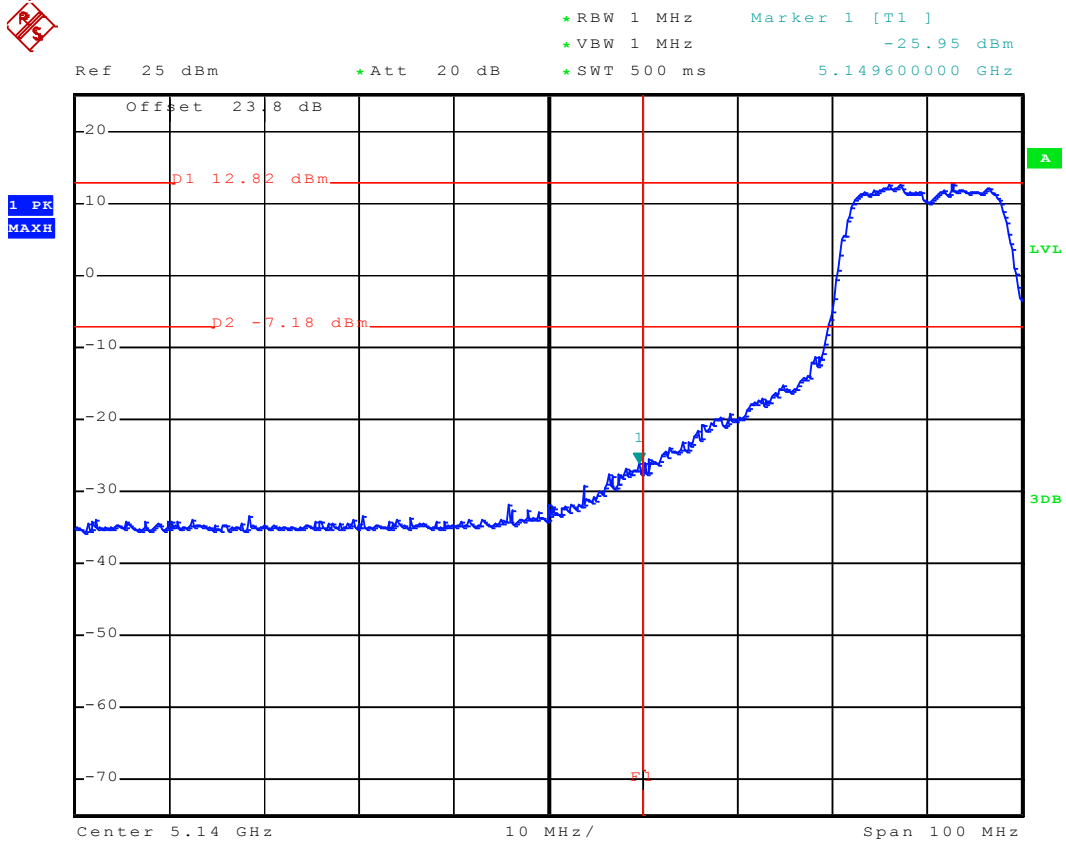

Date: 21.NOV.2007 23:40:11



Mode 6

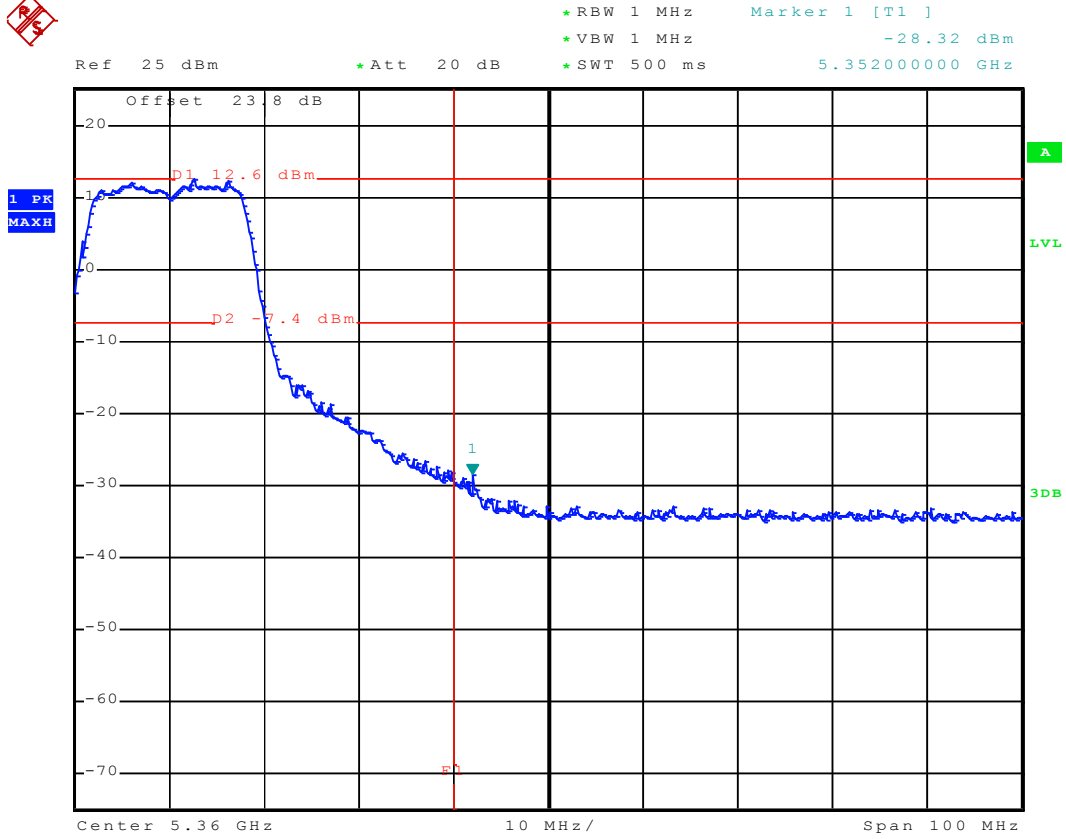

Date: 21.NOV.2007 23:37:34



Mode 7

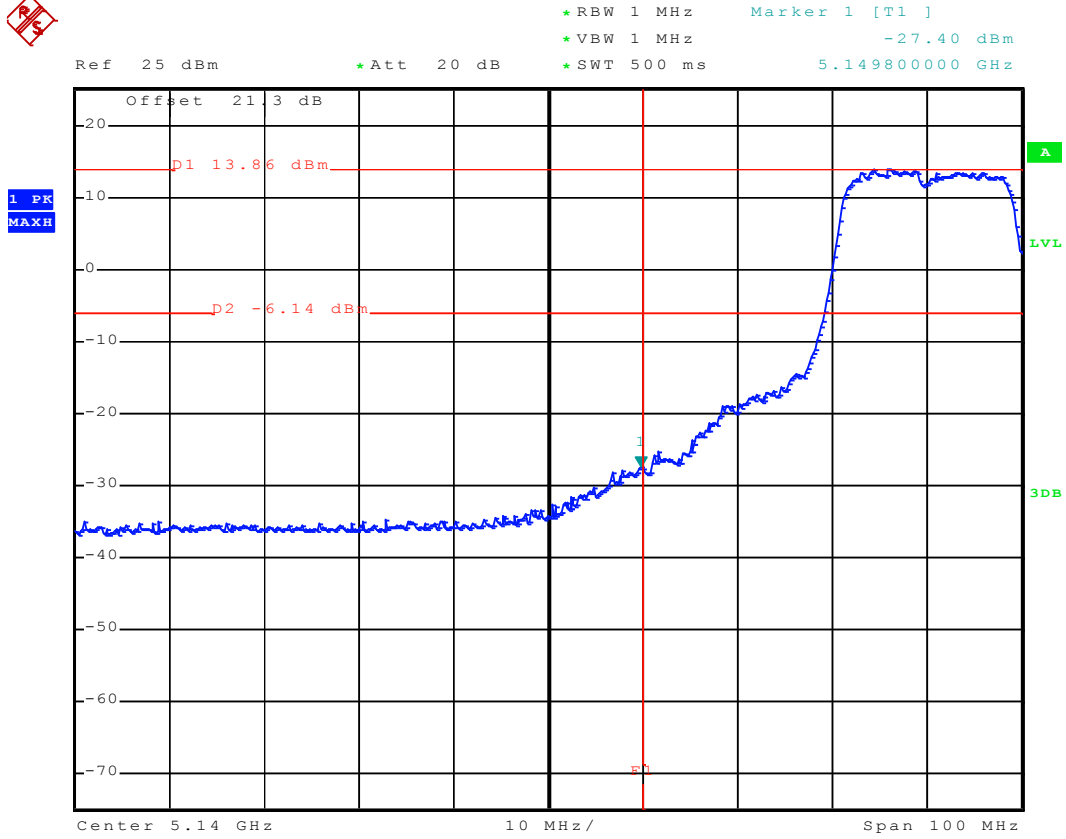

Date: 22.NOV.2007 00:50:58



Mode 12

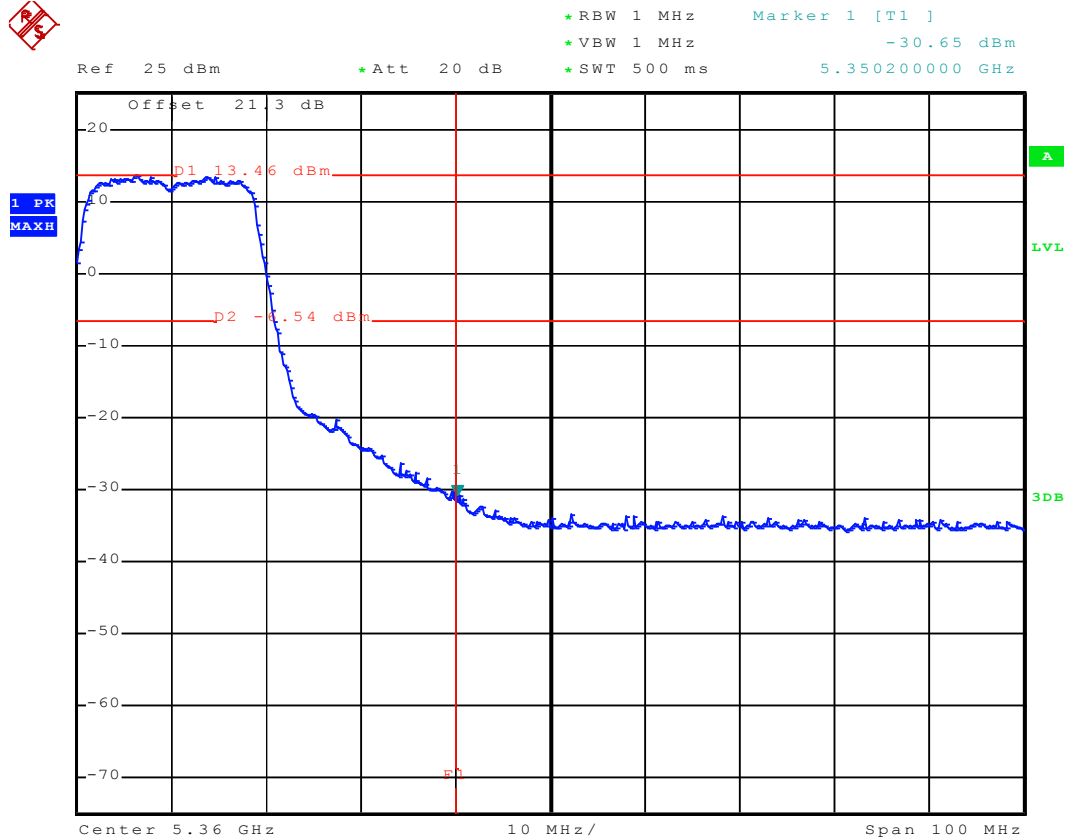

Date: 20.NOV.2007 15:08:04



Mode 13

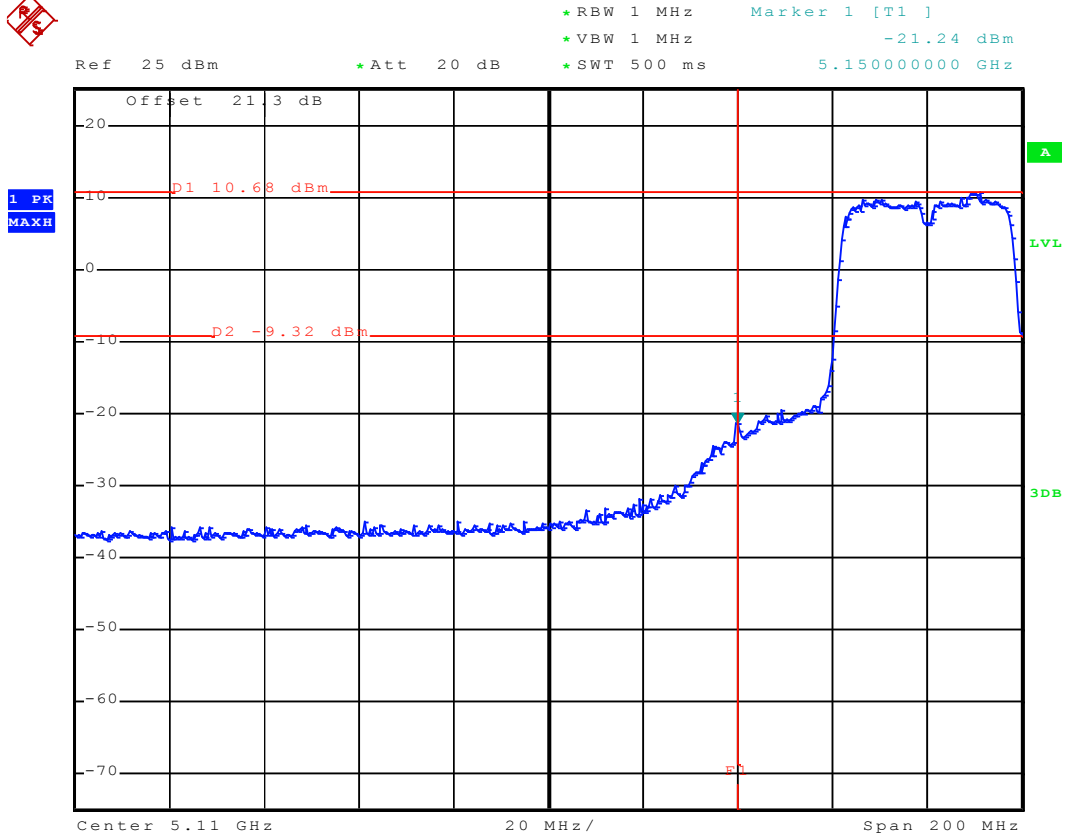

Date: 22.NOV.2007 01:56:16



Mode 16

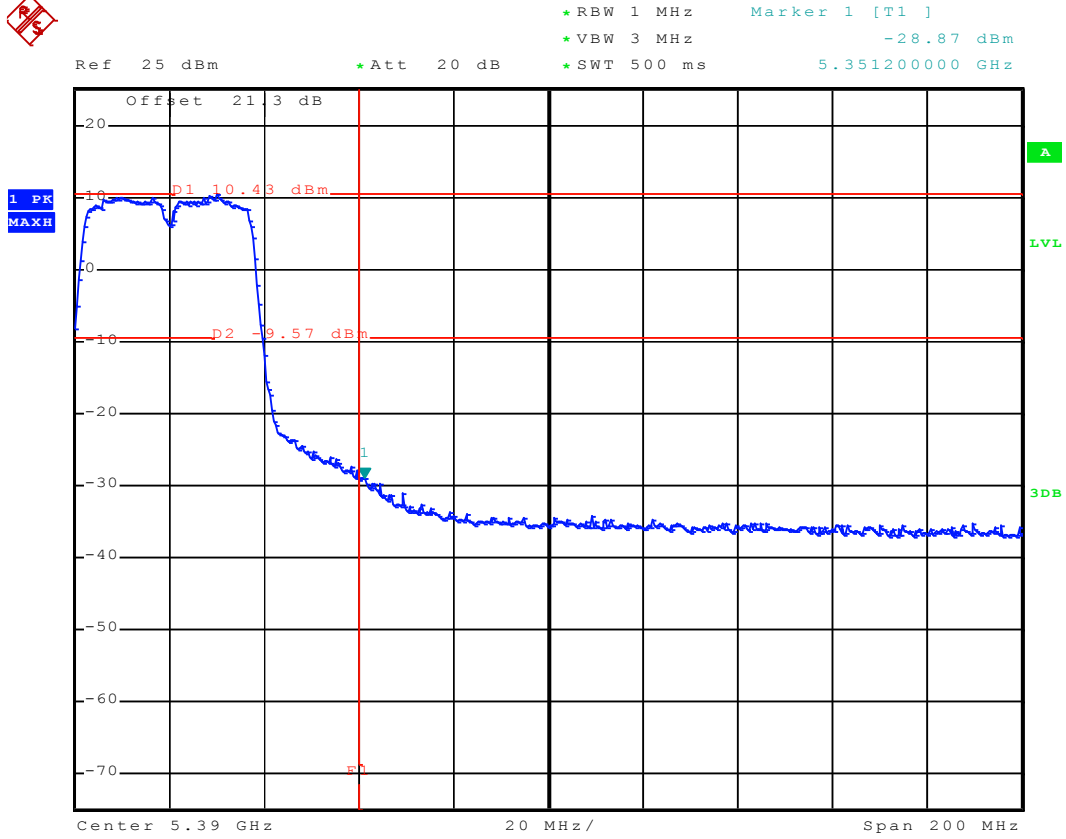

Date: 22.NOV.2007 01:04:42



5.8 Peak Excursion Ratio Measurement

5.8.1 Measuring Instruments

As described in chapter 6 of this test report.

5.8.2 Test Procedure

The transmitter output is connected to the spectrum analyzer. The resolution bandwidth is set to and maintained at 1 MHz. The video bandwidth is set to 3 MHz. Trace A is set peak detector and to Max Hold, then to View. Then the detector is readjusted to sample detector, max hold to run for 60 seconds, and the signal under this measurement condition is captured in Trace B in Accordance with the method 3 of DA-02-2138.

The difference between the traces is investigated. The marker is placed at the frequency which shows the largest difference. The amplitude delta between the traces at this frequency is the peak excursion.

5.8.3 Test Setup Layout

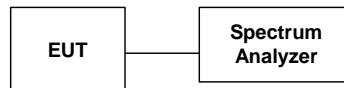



5.8.4 Test Result :

- Temperature : 25~26°C
- Relative Humidity : 49~51%
- Test Engineer : CKC

➤ 802.11a Normal mode

Channel	Frequency (MHz)	Peak Excursion (dB)	Limits (MHz)	Plot Ref. No.
36	5180	-8.00	13	Mode 1
44	5220	-9.12	13	Mode 2
48	5240	-7.08	13	Mode 3
52	5260	-9.10	13	Mode 4
60	5300	-8.18	13	Mode 5
64	5320	-7.78	13	Mode 6

➤ 802.11n(a) BW 20M mode

Channel	Frequency (MHz)	Peak Excursion (dB)	Limits (MHz)	Plot Ref. No.
36	5180	-8.30	13	Mode 7
44	5220	-8.70	13	Mode 8
48	5240	-7.42	13	Mode 9
52	5260	-7.87	13	Mode 10
60	5300	-8.74	13	Mode 11
64	5320	-7.11	13	Mode 12



➤ **802.11n(a) BW 40M mode**

Channel	Frequency (MHz)	Peak Excursion (dB)	Limits (MHz)	Plot Ref. No.
38	5190	-10.52	13	Mode 13
46	5230	-11.95	13	Mode 14
54	5270	-10.24	13	Mode 15
62	5310	-10.84	13	Mode 16



5.8.5 Test Data

Mode 1

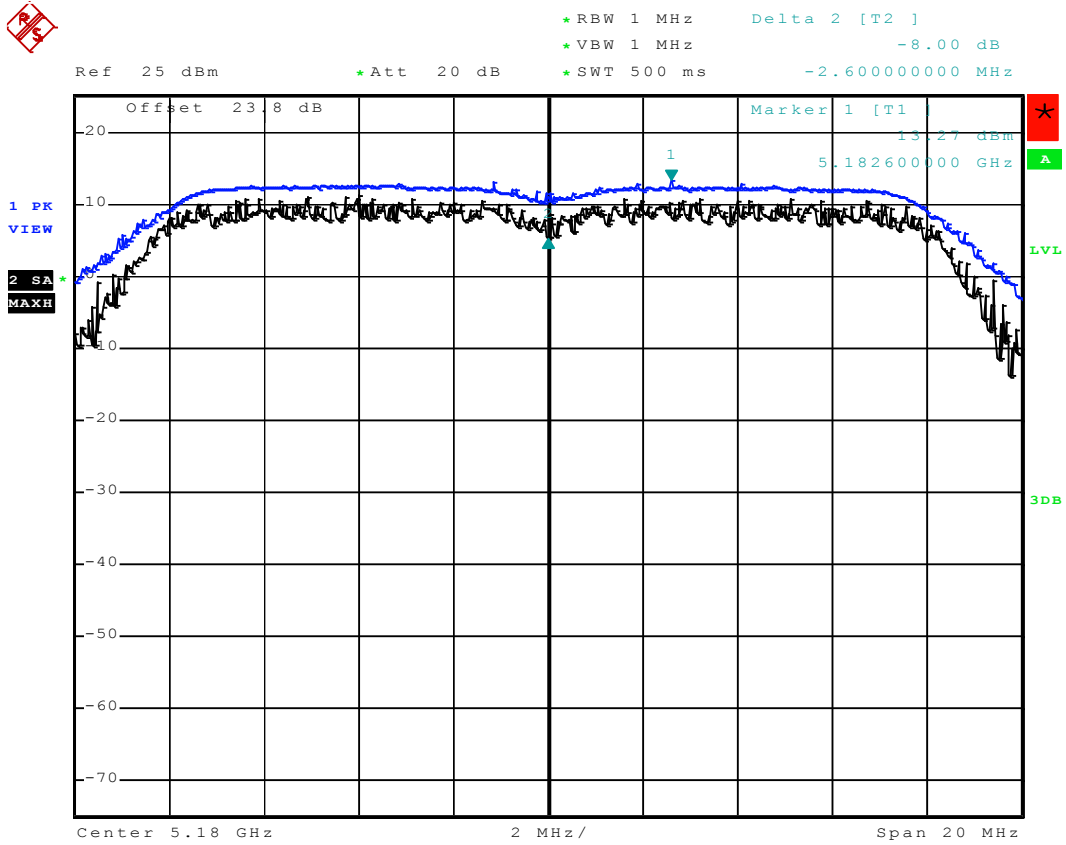

Date: 9.NOV.2007 16:08:41



Mode 2

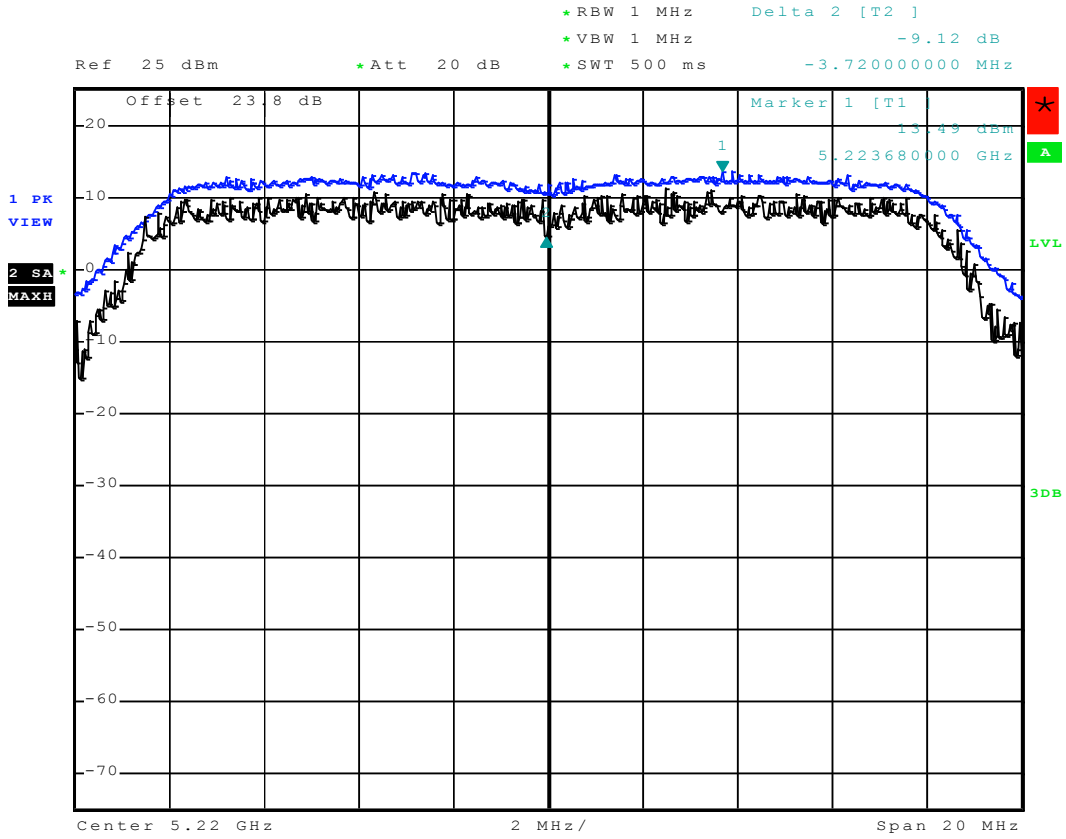

Date: 5.JAN.2008 00:58:08



Mode 3

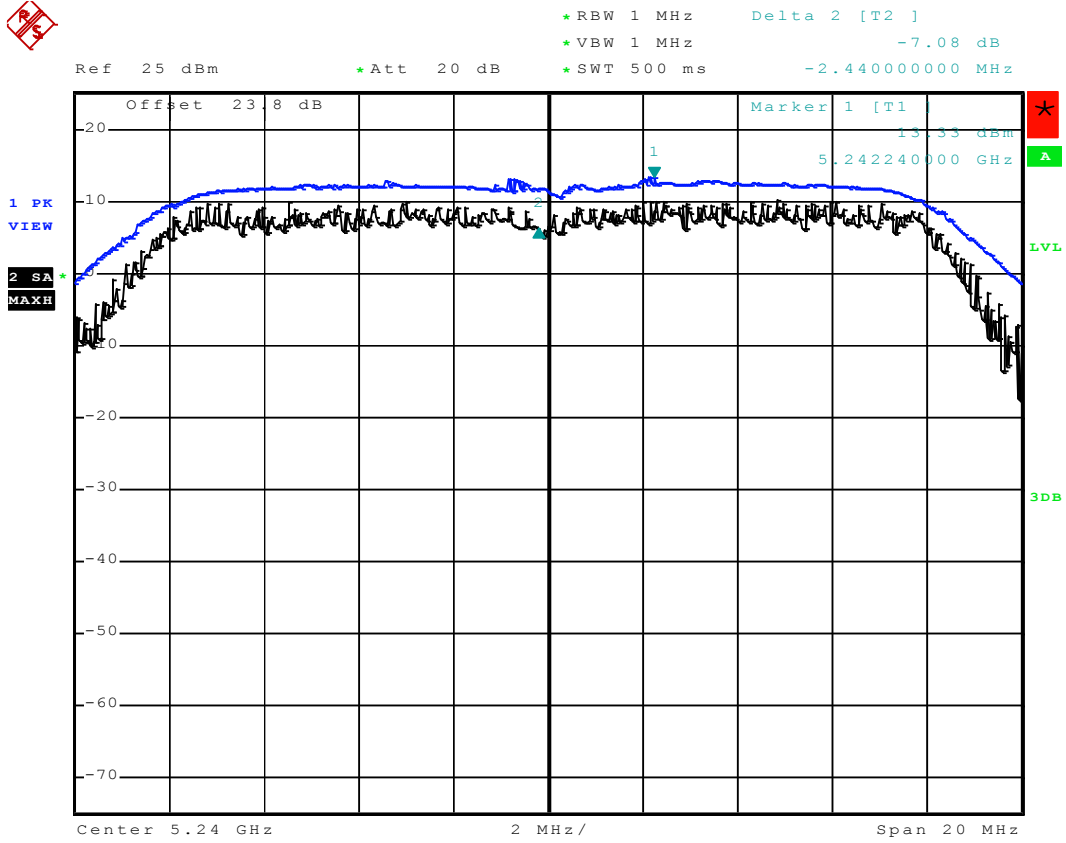

Date: 9.NOV.2007 16:06:43



Mode 4

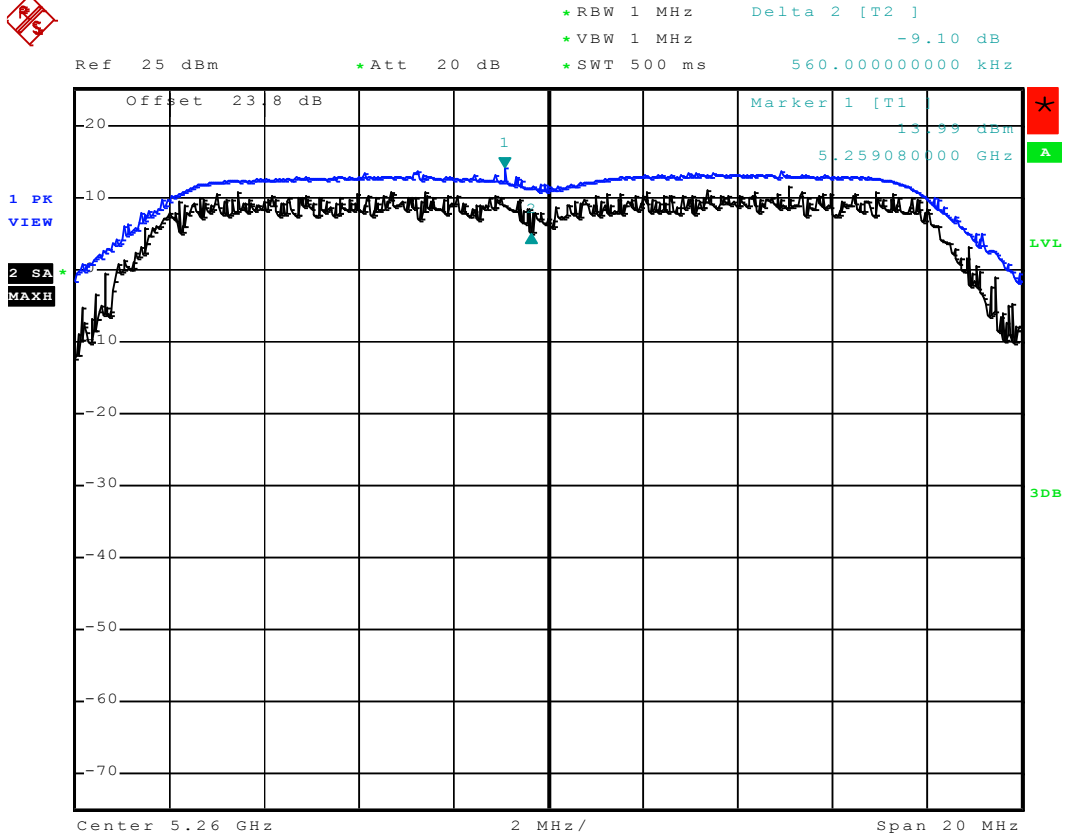

Date: 9.NOV.2007 16:04:09



Mode 5

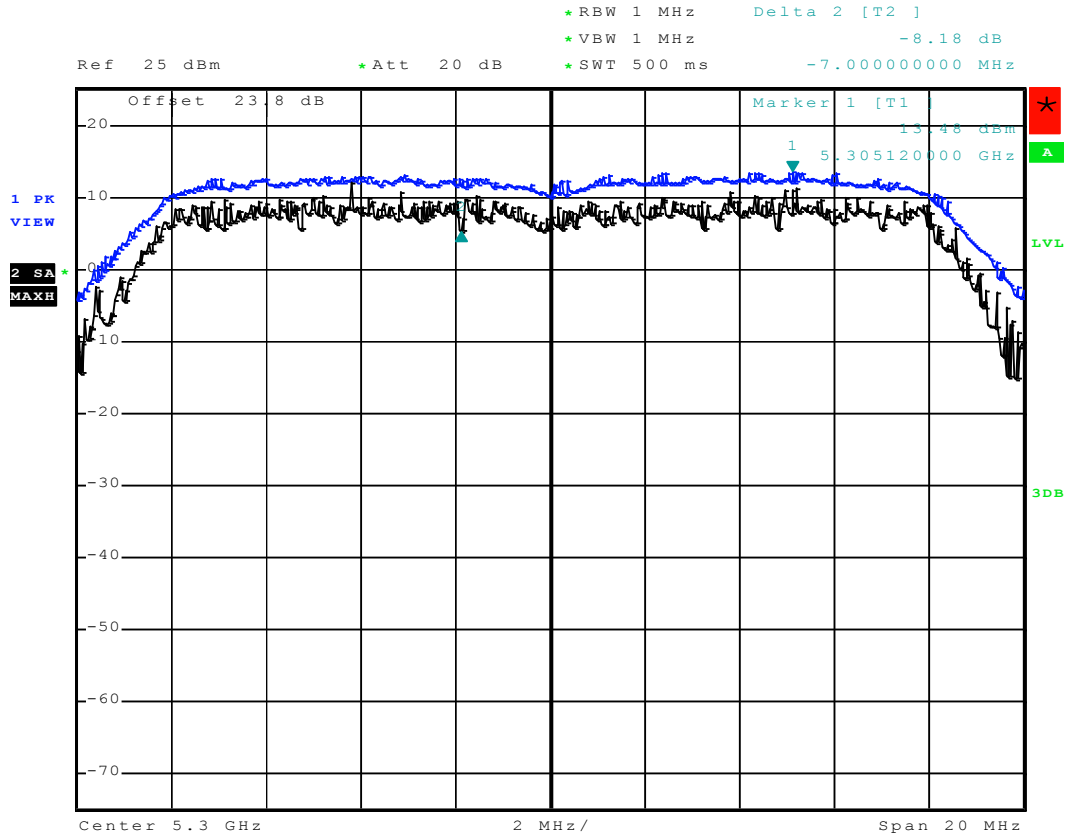

Date: 5.JAN.2008 00:52:27



Mode 6

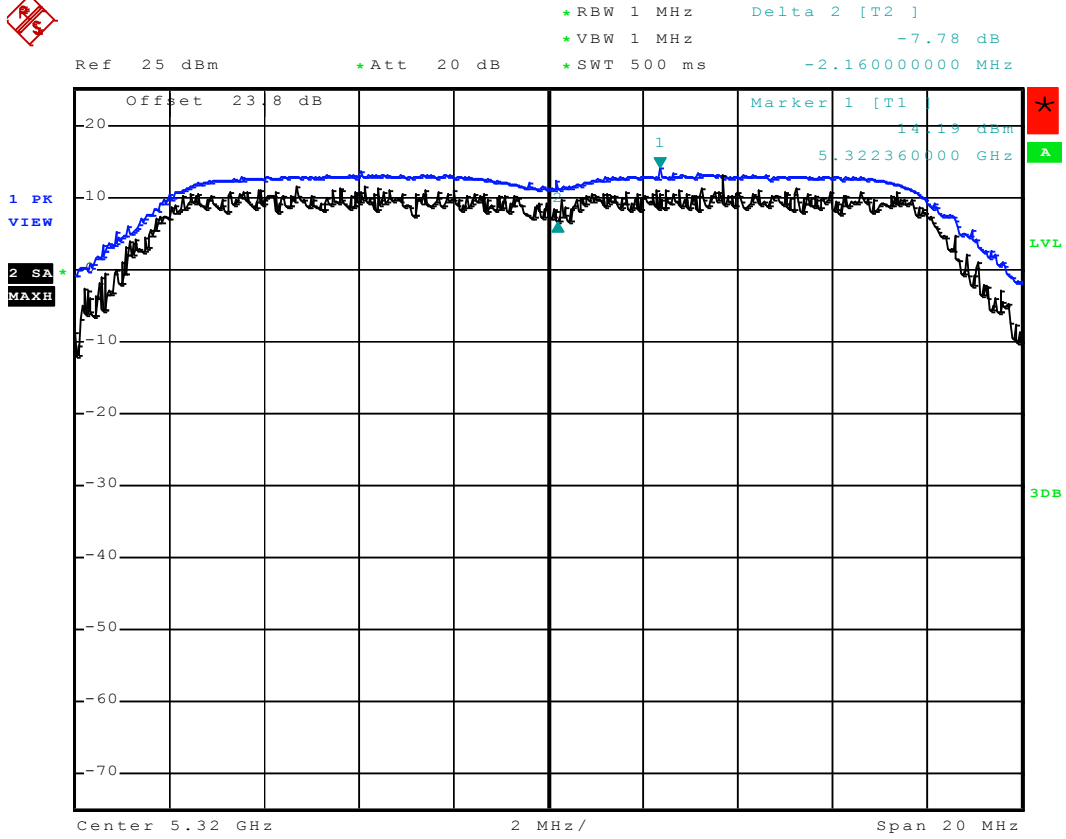

Date: 9.NOV.2007 16:02:47



Mode 7

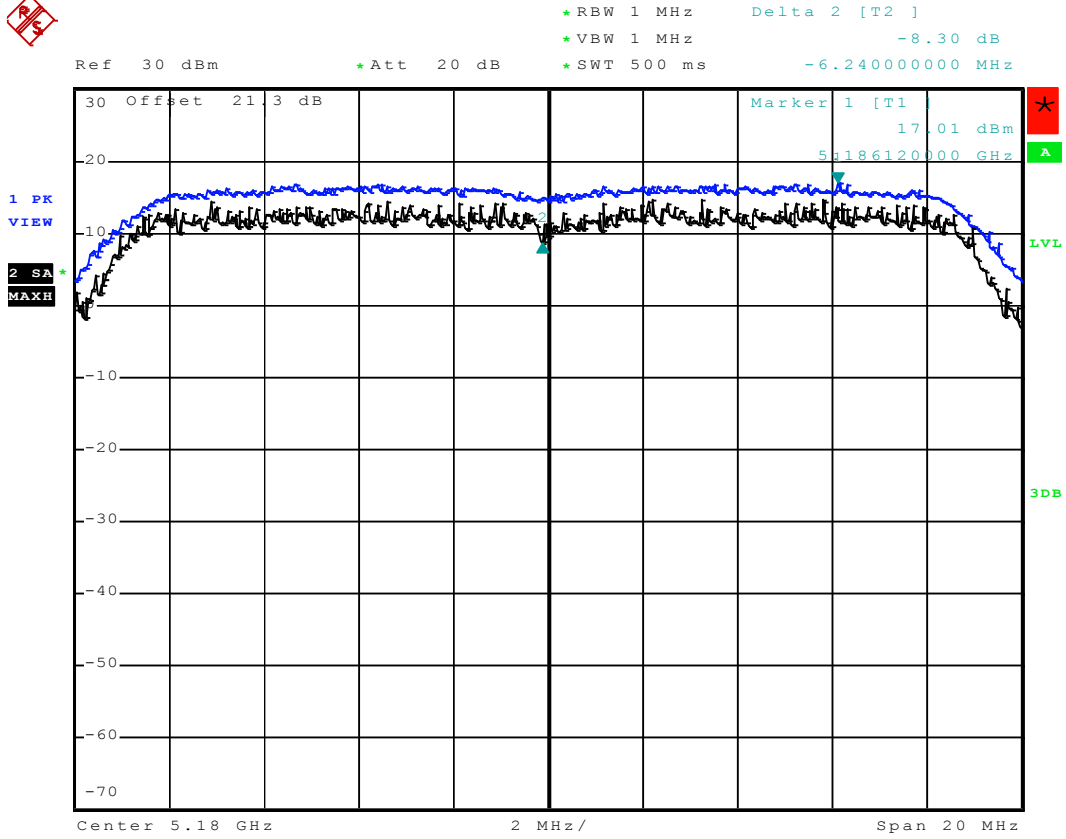

Date: 8.NOV.2007 16:39:24



Mode 8



*RBW 1 MHz Delta 2 [T2]
 *VBW 1 MHz -8.70 dB
 *Att 20 dB *SWT 500 ms -3.680000000 MHz
 Ref 30 dBm

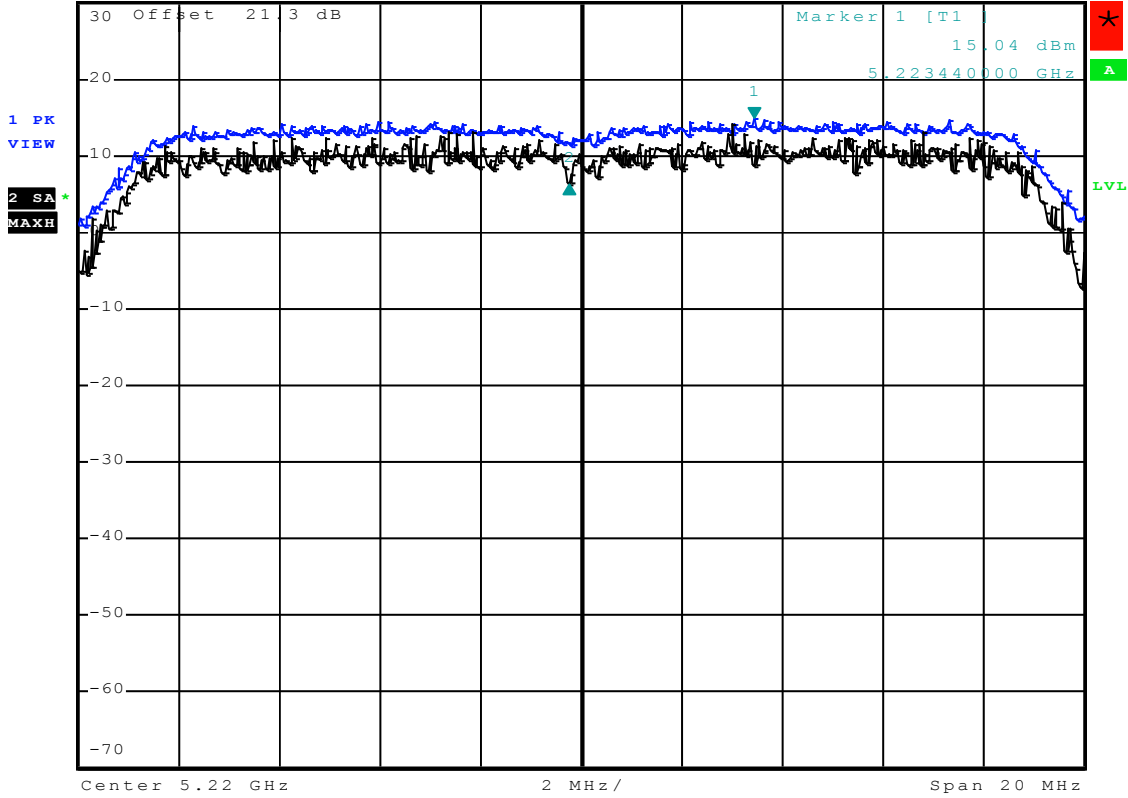

Date: 7.JAN.2008 18:19:13



Mode 9

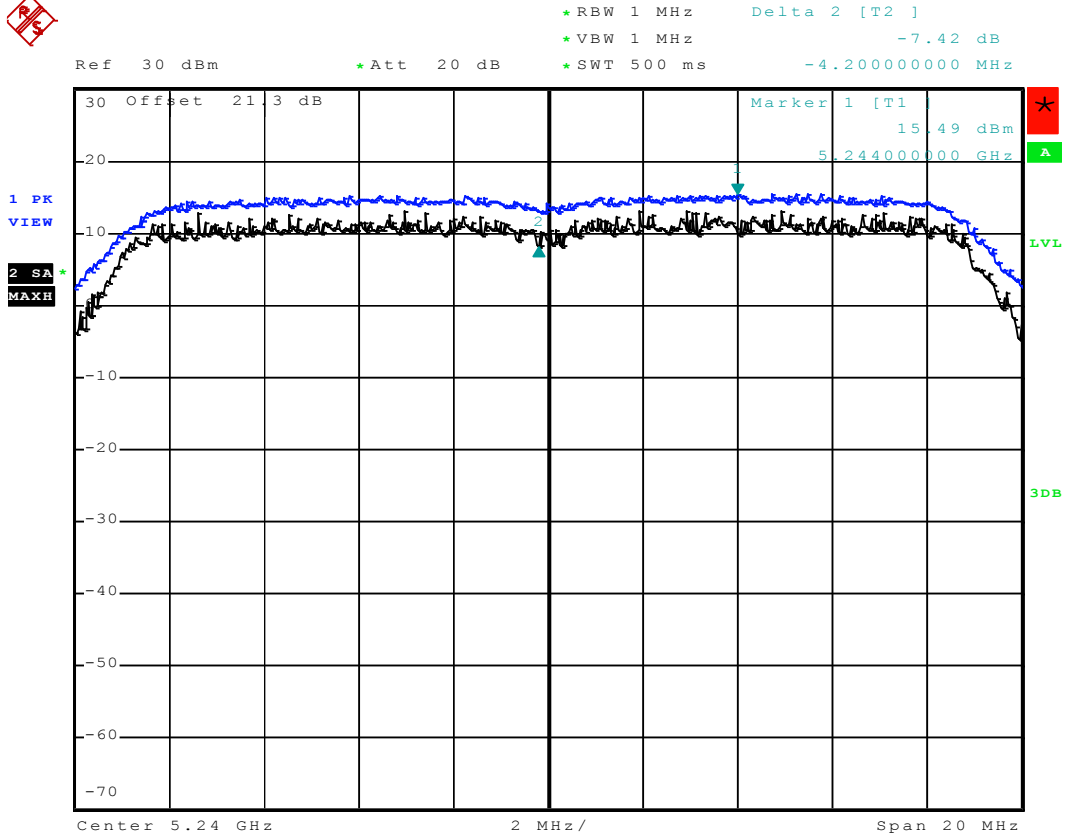

Date: 8.NOV.2007 16:37:35



Mode 10

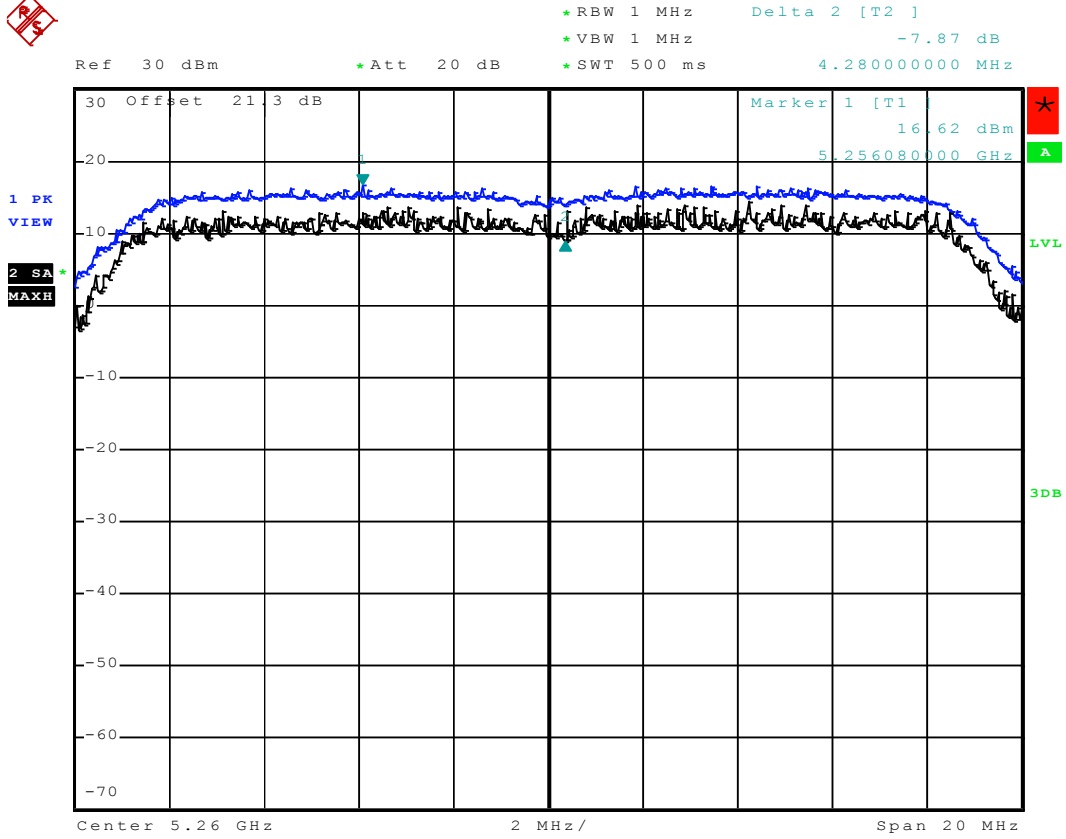

Date: 8.NOV.2007 16:41:01



Mode 11



Ref 30 dBm * Att 20 dB * RBW 1 MHz Delta 2 [T2]
* VBW 1 MHz -8.74 dB
* SWT 500 ms 2.320000000 MHz

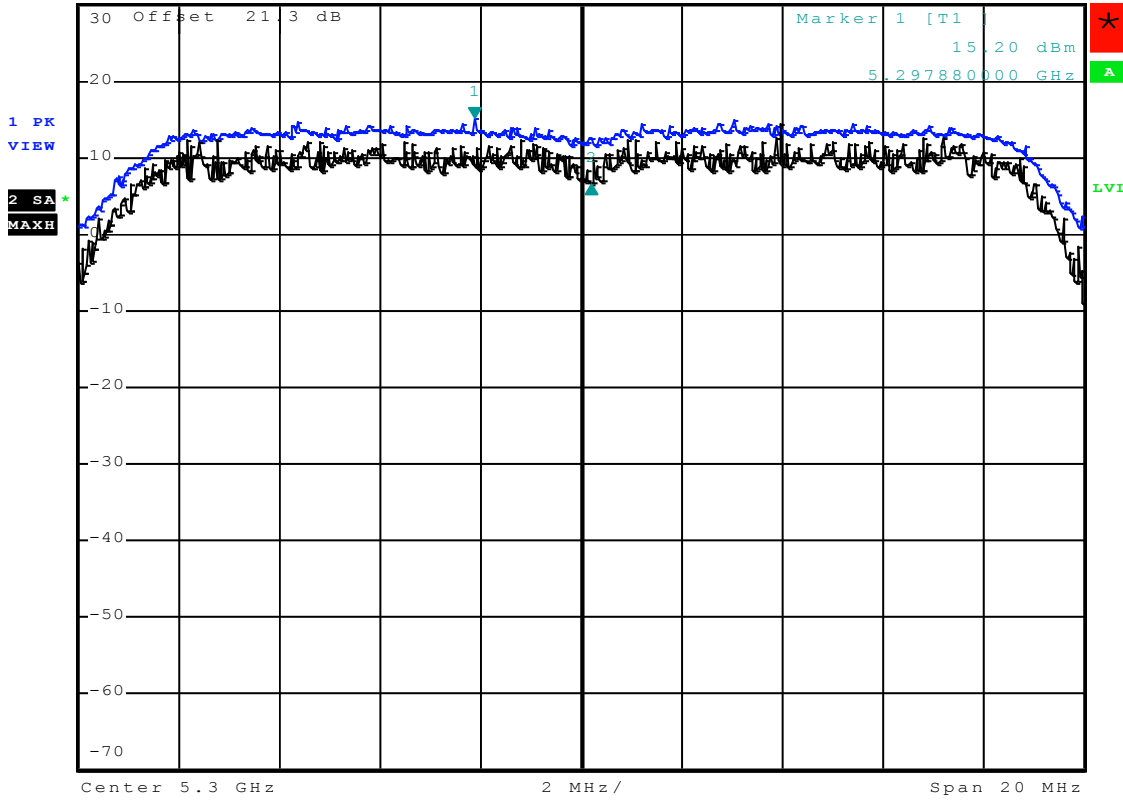

Date: 7.JAN.2008 18:12:22



Mode 12

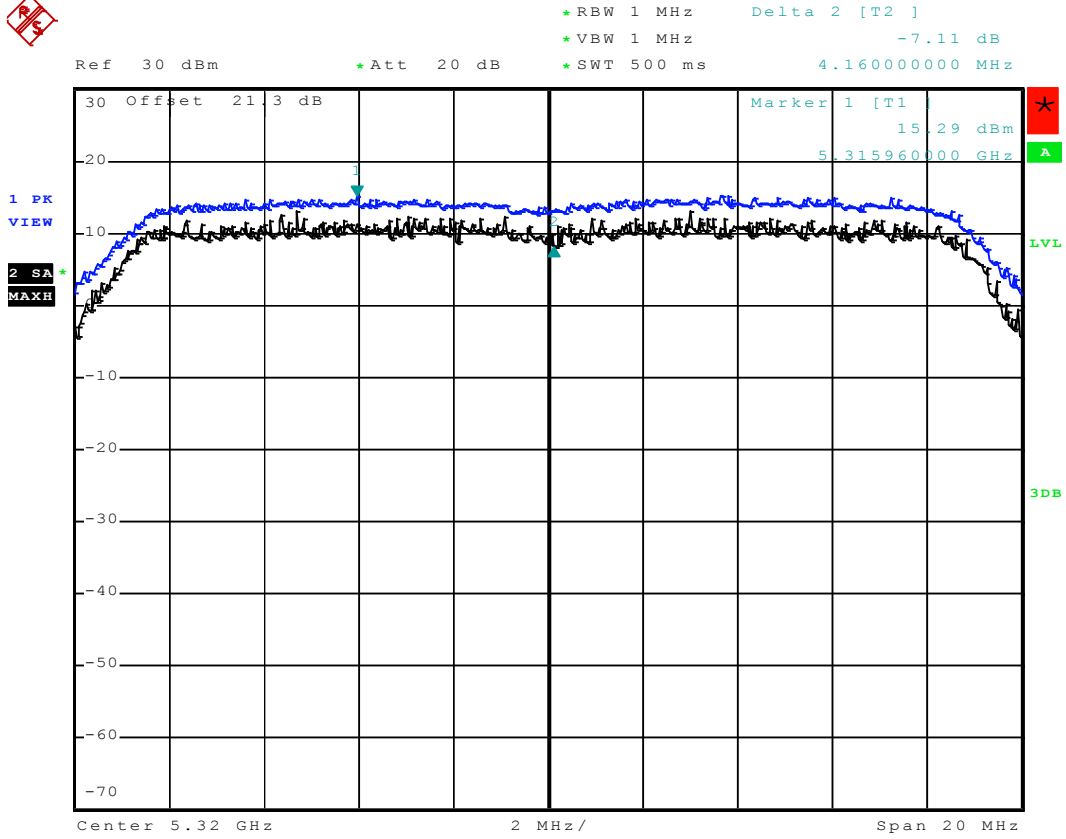

Date: 8.NOV.2007 16:43:14



Mode 13

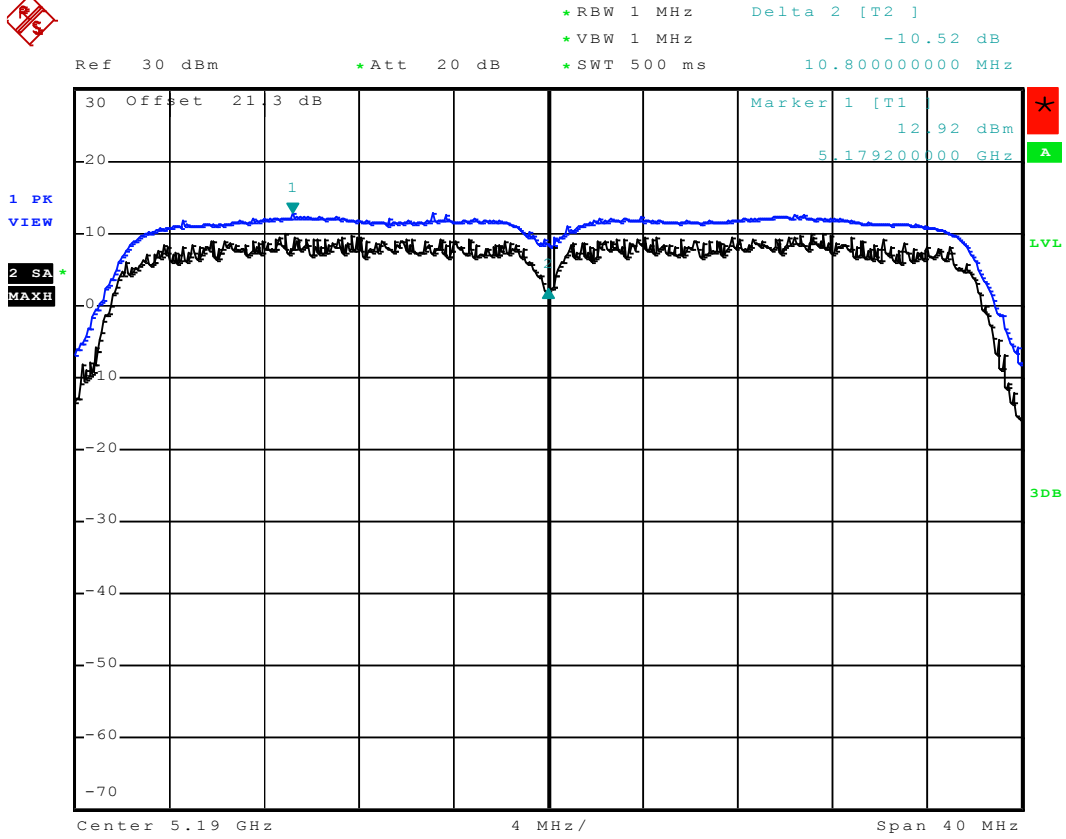

Date: 8.NOV.2007 16:45:40



Mode 14



*RBW 1 MHz Delta 2 [T2]
 *VBW 1 MHz -11.95 dB
 *Att 20 dB *SWT 500 ms -9.920000000 MHz
 Ref 30 dBm Offset 21.3 dB

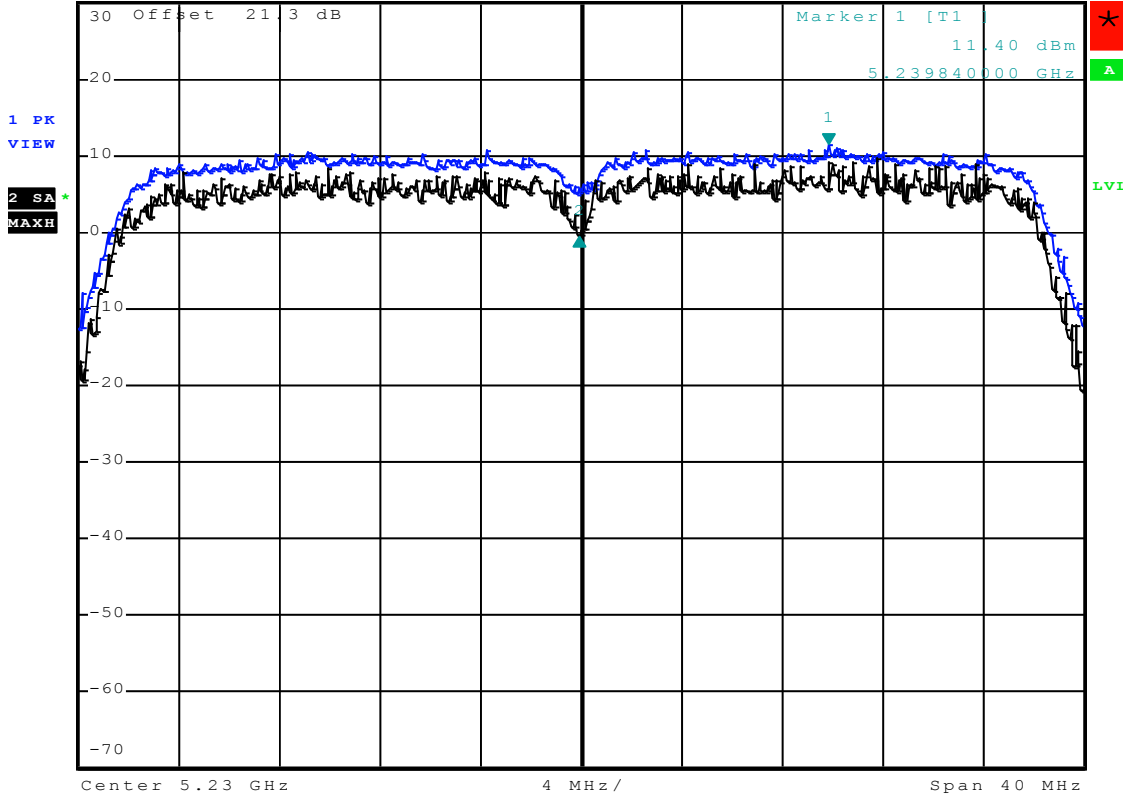

Date: 7.JAN.2008 18:25:58



Mode 15

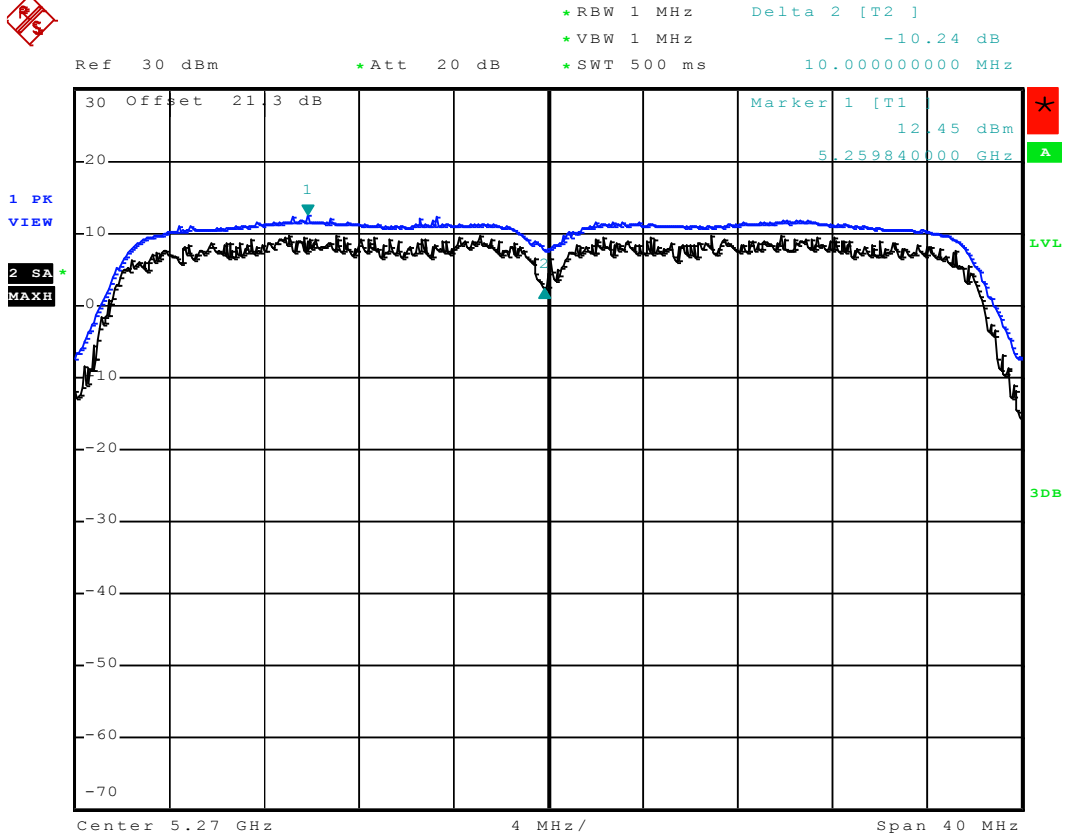

Date: 8.NOV.2007 16:47:49



Mode 16

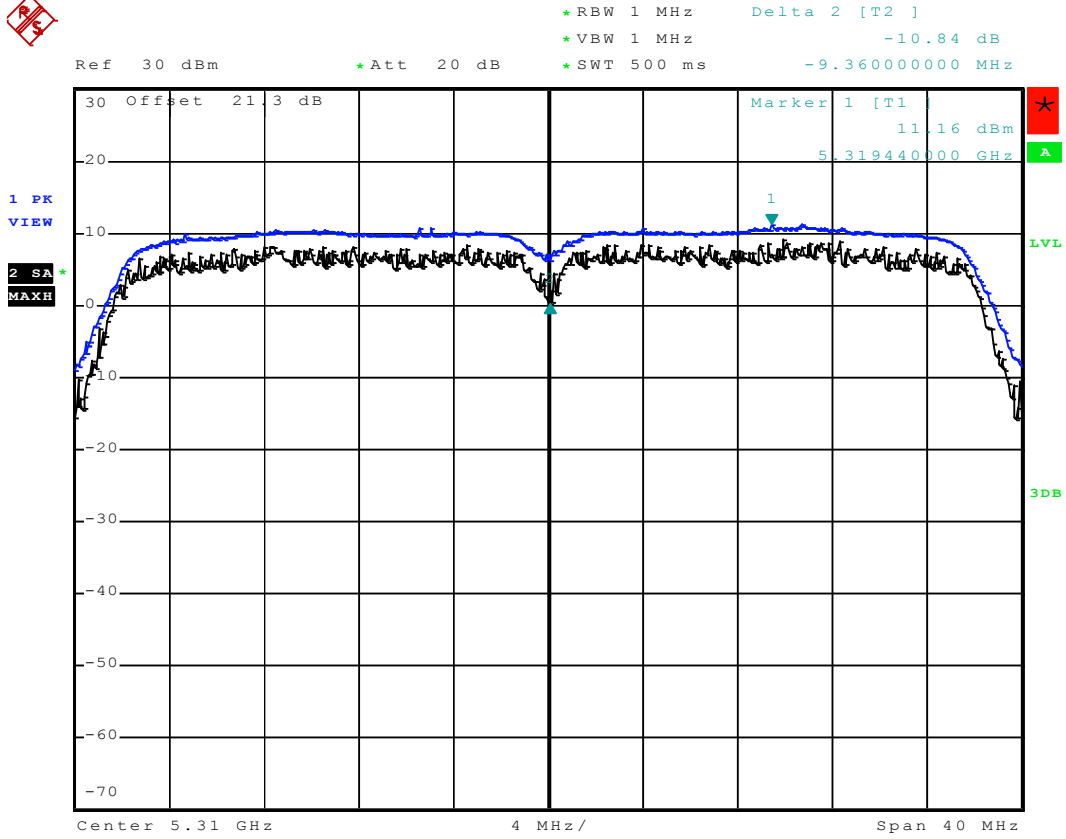

Date: 8.NOV.2007 16:49:52



5.9 Frequency Stability

To ensure emission at the band edge is maintained within the authorized band, those values shall be measured by radiation emissions at upper and lower frequency points, and finally compensated by frequency deviation as procedures below.

The EUT was operated at the maximum output power, and connected to the spectrum analyzer which is set to maximum hold function and peak detector. The peak value of the power envelope was measured and noted. The upper and lower frequency points were respectively measured relatively 10dB lower than the measured peak value. The frequency deviation was calculated by adding the upper frequency point and the lower frequency point divided by two. Those detailed values of frequency deviation are provided in table below.

➤ **802.11a Normal mode**

Frequency (MHz)	Low Frequency (Fl)	High Frequency (Fh)	Center Frequency (Fc)	Frequency Stability (ppm)
5180	5171.68	5188.28	5179.98	-0.02
5220	5211.64	5228.32	5219.98	-0.02
5240	5231.68	5248.32	5240.00	0.00
5260	5251.68	5268.32	5260.00	0.00
5300	5291.68	5308.28	5299.98	-0.02
5320	5311.68	5328.28	5319.98	-0.02

➤ **802.11n(a) BW 20M mode**

Frequency (MHz)	Low Frequency (Fl)	High Frequency (Fh)	Center Frequency (Fc)	Frequency Stability (ppm)
5180	5171.08	5188.92	5180.00	0.00
5220	5211.08	5228.92	5220.00	0.00
5240	5231.08	5248.92	5240.00	0.00
5260	5251.08	5268.92	5260.00	0.00
5300	5291.08	5308.96	5300.02	0.02
5320	5311.08	5328.92	5320.00	0.00



➤ 802.11n(a) BW 40M mode

Frequency (MHz)	Low Frequency (Fl)	High Frequency (Fh)	Center Frequency (Fc)	Frequency Stability (ppm)
5190	5171.76	5208.24	5190.00	0.00
5230	5211.68	5248.24	5229.96	-0.04
5270	5251.68	5288.24	5269.96	-0.04
5310	5291.76	5328.32	5310.04	0.04



5.10 Automatically discontinue transmission

During no any information transmission, the EUT can automatically discontinue transmission and become standby mode for power saving .The EUT can detect the controlling signal of ACK message transmitting from remote device and verify whether it shall resend or discontinue transmission .



5.11 Antenna Requirements

The EUT meets antenna requirement of FCC for the following reasons.

5.11.1 Standard Applicable

According to FCC 47 CFR Section 15.407(a)(1)(2), if transmitting antennas of directional gain greater than 6 dBi are used, both the peak transmit power and the peak power spectral density shall be reduced by the amount in dB that the directional gain of the antenna exceeds 6 dBi.

5.11.2 Antenna Connected Construction

The antenna used in this product is PIFA antenna for WLAN without connector and it is considered to meet antenna requirement of FCC.



5 List of Measuring Equipments

Instrument	Manufacturer	Model No.	Serial No.	Characteristics	Calibration Date	Due Date	Remark
EMC Receiver	R&S	ESCS 30	100359	9kHz – 2.75GHz	Mar. 01, 2007	Feb. 29, 2008	Conduction (CO04-HY)
LISN	MessTec	NNB-2/16Z	99079	9kHz – 30MHz	Mar. 31, 2007	Mar. 30, 2008	Conduction (CO04-HY)
LISN (Support Unit)	EMCO	3810/2NM	9703-1839	9kHz – 30MHz	Mar. 22, 2007	Mar. 21, 2008	Conduction (CO04-HY)
RF Cable-CON	UTIFLEX	3102-26886-4	CB049	9kHz – 30MHz	Apr. 20, 2007	Apr. 19, 2008	Conduction (CO04-HY)
ISN	SCHAFFNER	ISN T400	21653	9kHz –30MHz	Mar. 09, 2007	Mar. 08, 2008	Conduction (CO04-HY)
EMI Filter	LINDGREN	LRE-2030	2651	< 450 Hz	N/A	N/A	Conduction (CO04-HY)
Isolation Transformer	Erika Fiedler OHG	D-65396 Walluf	58	45MHz-2.15GHz	N/A	N/A	Conduction (CO04-HY)
3m Semi Anechoic	TDK	SAC-3M	03CH04-HY	30 MHz - 1 GHz 3m	Oct. 29, 2007	Oct. 28, 2008	Radiation (03CH04-HY)
Amplifier	HP	87405A	3950M00135	10MHz - 3 GHz	Mar. 02, 2007	Mar. 01, 2008	Radiation (03CH04-HY)
Spectrum Analyzer	R&S	FSP40	100305	9 kHz – 40GHz	Sep. 27, 2007	Sep. 26, 2008	Radiation (03CH04-HY)
Bilog Antenna	SCHAFFNER	CBL6112B	2724	30 MHz - 1 GHz	Aug. 13, 2007	Aug. 12 2008	Radiation (03CH04-HY)
Turn Table	HD	Deis HD 2000	420/610	0 - 360 degree	N/A	N/A	Radiation (03CH04-HY)
Antenna Mast	Chaintek	3000	N/A	1 m - 4 m	N/A	N/A	Radiation (03CH04-HY)
RF Cable-R03m	Suhner Switzerland + RFIDEN	RG223/U +RG8/U	CB024	30 MHz - 1 GHz	Sep. 20, 2007	Sep. 19, 2008	Radiation (03CH04-HY)
Isolation Transformer	Erika FiedLer OHG	D-65396 Walluf	N/A	45 MHz – 2.15 GHz 30dB	N/A	N/A	Radiation (03CH04-HY)



6 Uncertainty of Test Site

Uncertainty of Conducted Emission Measurement (150kHz ~ 30MHz)

Contribution	Uncertainty of x_i		$u(x_i)$
	dB	Probability Distribution	
Receiver reading	0.10	Normal(k=2)	0.05
Cable loss	0.10	Normal(k=2)	0.05
AMN insertion loss	2.50	Rectangular	0.63
Receiver Spec	1.50	Rectangular	0.43
Site imperfection	1.39	Rectangular	0.80
Mismatch	+0.34/-0.35	U-shape	0.24
Combined standard uncertainty Uc(y)	1.13		
Measuring uncertainty for a level of Confidence of 95% U=2Uc(y)	2.26		

Uncertainty of Radiated Emission Measurement (30MHz ~ 1000MHz)

Contribution	Uncertainty of x_i		$u(x_i)$
	dB	Probability Distribution	
Receiver reading	0.41	Normal(k=2)	0.21
Antenna factor calibration	0.83	Normal(k=2)	0.42
Cable loss calibration	0.25	Normal(k=2)	0.13
Pre Amplifier Gain calibration	0.27	Normal(k=2)	0.14
RCV/SPA specification	2.50	Rectangular	0.72
Antenna Factor Interpolation for Frequency	1.00	Rectangular	0.29
Site imperfection	1.43	Rectangular	0.83
Mismatch	+0.39/-0.41	U-shaped	0.28
Combined standard uncertainty Uc(y)	1.27		
Measuring uncertainty for a level of Confidence of 95% U=2Uc(y)	2.54		



Uncertainty of Radiated Emission Measurement (1GHz ~ 40GHz)

Contribution	Uncertainty of x_i		$u(x_i)$	C_i	$C_i * u(x_i)$
	dB	Probability Distribution			
Receiver reading	±0.10	Normal(k=1)	0.10	1	0.10
Antenna factor calibration	±1.70	Normal(k=2)	0.85	1	0.85
Cable loss calibration	±0.50	Normal(k=2)	0.25	1	0.25
Receiver Correction	±2.00	Rectangular	1.15	1	1.15
Antenna Factor Directional	±1.50	Rectangular	0.87	1	0.87
Site imperfection	±2.80	Triangular	1.14	1	1.14
Mismatch Receiver VSWR $\Gamma_1 = 0.197$ Antenna VSWR $\Gamma_2 = 0.194$ Uncertainty = $20 \log(1 - \Gamma_1 * \Gamma_2 * \Gamma_3)$	+0.34/-0.35	U-shaped	0.244	1	0.244
Combined standard uncertainty $U_c(y)$	2.36				
Measuring uncertainty for a level of Confidence of 95% $U = 2U_c(y)$	4.72				

The measured result is : y dBuV $\pm U$ dB
 for a level of confidence of approximately 95% , ($k = 2$)



Appendix A. Photographs of EUT

Please refer to Sporton report number EP980406 as below.