



**FCC 47 CFR PART 15 SUBPART C AND ANSI C63.4 : 2003**

**TEST REPORT ( Class II Permissive Change Report )**

**For**

**BLUETOOTH MODULE**

**Model : GUBTCR42M**

**Trade Name : Getac**

**Issued for**

**Getac Technology Corp.**

**No. 1, R&D Road 2, Hsinchu Science Based Industrial Park,  
Hsinchu, Taiwan**

**Issued by**

**Compliance Certification Services Inc.**

**Tainan Laboratory**

No. 8, Jiu Cheng Ling, Jiaokeng Village, Sinhua  
Township, Tainan Hsien 712, Taiwan R.O.C.

**TEL: 886-6-580-2201**

**FAX: 886-6-580-2202**



---

***Note:** This report shall not be reproduced except in full, without the written approval of Compliance Certification Services Inc. This document may be altered or revised by Compliance Certification Services Inc. personnel only, and shall be noted in the revision section of the document. The client should not use it to claim product endorsement by TAF or any government agencies. The test results in the report only apply to the tested sample.*



## Revision History

<b>Rev.</b>	<b>Issue Date</b>	<b>Revisions</b>	<b>Effect Page</b>	<b>Revised By</b>
00	11/18/2009	Initial Issue	All Page 41	Jeter Wu



**TABLE OF CONTENTS**

TITLE	PAGE NO.
<b>1. TEST REPORT CERTIFICATION.....</b>	<b>4</b>
<b>2. EUT DESCRIPTION.....</b>	<b>5</b>
2.1 DESCRIPTION OF EUT & POWER.....	5
2.2 DESCRIPTION OF CLASS II CHANGE.....	5
<b>3. DESCRIPTION OF TEST MODES.....</b>	<b>6</b>
<b>4. TEST METHODOLOGY.....</b>	<b>7</b>
<b>5. FACILITIES AND ACCREDITATIONS.....</b>	<b>7</b>
5.1 FACILITIES.....	7
5.2 EQUIPMENT.....	7
5.3 LABORATORY ACCREDITATIONS LISTINGS.....	7
5.4 TABLE OF ACCREDITATIONS AND LISTINGS.....	8
<b>6. CALIBRATION AND UNCERTAINTY.....</b>	<b>9</b>
6.1 MEASURING INSTRUMENT CALIBRATION.....	9
6.2 MEASUREMENT UNCERTAINTY.....	9
<b>7. SETUP OF EQUIPMENT UNDER TEST.....</b>	<b>10-12</b>
<b>8. APPLICABLE LIMITS AND TEST RESULTS.....</b>	<b>12</b>
8.1 RADIATED EMISSIONS.....	12
8.1.1 TRANSMITTER RADIATED SUPURIOUS EMSSIONS.....	12-15
8.1.2 WORST-CASE RADIATED EMISSION BELOW 1 GHz.....	16-21
8.2 POWERLINE CONDUCTED EMISSIONS.....	22-35
<b>APPENDIX SETUP PHOTOS.....</b>	<b>36-41</b>



# 1. TEST REPORT CERTIFICATION

**Applicant** : Getac Technology Corp.  
**Address** : No. 1, R&D Road 2, Hsinchu Science Based Industrial Park,  
Hsinchu, Taiwan  
**Equipment Under Test** : BLUETOOTH MODULE  
**Model** : GUBTCR42M  
**Trade Name** : Getac  
**Tested Date** : October 20 ~ November 16, 2009

APPLICABLE STANDARD	
STANDARD	TEST RESULT
FCC Part 15 Subpart C AND ANSI C63.4:2003	PASS

Approved by:

Jeter Wu  
Section Manager

Reviewed by:

Eric Yang  
Assistant Section Manager

WE HEREBY CERTIFY THAT: The measurements shown in the attachment were made in accordance with the procedures indicated, and the energy emitted by the equipment was found to be within the limits applicable. We assume full responsibility for the accuracy and completeness of these measurements and vouch for the qualifications of all persons taking them.



## 2. EUT DESCRIPTION

### 2.1 DESCRIPTION OF EUT & POWER

<b>Product Name</b>	BLUETOOTH MODULE
<b>Model Number</b>	GUBTCR42M
<b>Frequency Range</b>	2402MHz to 2480MHz
<b>Number of Channels</b>	79
<b>Carrier Frequency of Each Channel</b>	$f = 2402 + n\text{MHz}$ , $n = 0, \dots, 78$
<b>Channel Spacing</b>	1MHz
<b>Transmit Power</b>	Bluetooth : 0.002W(1Mbps) Bluetooth EDR : 0.001W(2Mbps) 0.001W(3Mbps)
<b>Antenna Type</b>	PIFA Antenna, Antenna Gain 4dBi
<b>Type of Modulation</b>	Bluetooth (1Mbps) : GFSK Bluetooth EDR (2Mbps) : $\pi/4$ -DQPSK Bluetooth EDR (3Mbps) : 8-DPSK

**Remark:**

1. The sample selected for test was engineering sample that approximated to production product and was provided by manufacturer.
2. This submittal(s) (test report) is intended for FCC ID: MAU035 filing to comply with Section 15.207, 15.209 and 15.247 of the FCC Part 15, Subpart C Rules.
3. For more details, please refer to the User's manual of the EUT.

### 2.2 DESCRIPTION OF CLASS II CHANGE

The major change filed under this application are :

1. Add a notebook top enclosure shape. (original notebook LCD panel is for 10.4", new enclosure is for 12.1")
2. Add a non-approved notebook LED backlight module for notebook LCD panel (Toshiba / LTD121EXEV/12.1" notebook LCD panel)



### 3. DESCRIPTION OF TEST MODES

The EUT (GUBTCR42M) has been tested under normal operating condition.

Only Test validation Radiated Emission Test (Below 1 GHz) and Power line Conducted Emissions.

EMC Pretest Configurations

The following test mode(s) were scanned during the preliminary test.

SKU	CATEGORY	EMC/RF	EMC/RF	EMC/RF
ITEMs		EMC-1 for RD	EMC-2 for RD	EMC-3 for RD
<b>CPU</b>	<b>Type</b>	INTEL SU9400 Core2Duo ULV 1.4GHz	INTEL SU9400 Core2Duo ULV 1.4GHz	INTEL SU9400 Core2Duo ULV 1.4GHz
<b>Memory</b>	<b>Module Type</b>	DDRII SO-DIMM 4GB	DDRII SO-DIMM 2GB	DDRII SO-DIMM 4GB
<b>Turbo memory</b>	<b>Turbo Memory</b>	4GB; intel Mini PCI-E	4GB; intel Mini PCI-E	4GB; intel Mini PCI-E
<b>HDD</b>	<b>Capacity</b>	320GB	160GB	320GB
<b>DISPLAY</b>	<b>Size</b>	12.1"	12.1"	10.4"
	<b>Touchscreen</b>	Mildex T/S & Waltop Digitizer Co-existence.	Mildex T/S & Waltop Digitizer Co-existence.	Mildex T/S & Waltop Digitizer Co-existence.
	<b>Digitizer</b>			
	<b>Night vision</b>	yes	yes	yes
	<b>Panel</b>	Toshiba Upto 1000 Nist LED panel (After T/S),(Dual mode)	Toshiba Upto 500 Nist CCFL panel (After T/S),(Dual mode)	CPT Upto 1200 Nist Led panel (After T/S),(Dual mode)
<b>KBD</b>	<b>Layout</b>	US	US	US
	<b>Others</b>	rubber keyboard with BackLight	membrane keyboard	membrane keyboard
<b>PC Card /Express Card/Smart card reader</b>	<b>Configuration</b>	Smart Card Reader x 1 + Express Card x 1 ,co-existent	Smart Card Reader x 1 + Express Card x 1 ,co-existent	Smart Card Reader x 1 + PCMCIA Type II x 1
<b>Docking Port</b>	<b>Docking</b>	1 (100 pins)	1 (100 pins)	1 (100 pins)
<b>Pass Through Function</b>	<b>3G/WLAN pass through ANT conn</b>	Yes	Yes	Yes
<b>Communication</b>	<b>WLAN</b>	Intel® GUBTCR42M 3x3 802.11agn	Intel® GUBTCR42M 3x3 802.11agn	Intel® GUBTCR42M 3x3 802.11agn
	<b>Bluetooth</b>	Yes	Yes	Yes
	<b>3G Gobi2</b>	Gobi2	Gobi2	Gobi2
	<b>GPS</b>	Camera + GPS	Camera	GPS
<b>New Feature</b>	<b>Web Camera</b>			
<b>Battery</b>	<b>Number of Cell</b>	9 Cells	9 Cells	9 Cells
<b>AC Adapter</b>	<b>Type</b>	GTK 60W	GTK 60W	GTK 60W
<b>I/O Port</b>		RS232+RS422	RS232 + VGA	RS232+VGA
<b>HDD Heater</b>		Yes	Yes	Yes
<b>Touch Pad</b>		STD	Glove Touch pad	Glove Touch pad
<b>O.S</b>		WINDOWS XP	WINDOWS XP	WINDOWS XP
<b>Power adapter</b>	<b>ADM-6519M</b>	✓	✓	✓
	<b>ADM-9019M</b>	✓	✓	✓

Note: After evaluated the samples, for modes (worst case) are chosen as a representative.



## **4. TEST METHODOLOGY**

The tests documented in this report were performed in accordance with ANSI C63.4:2003 and FCC CRF 47 15.207, 15.209 and 15.247.

## **5. FACILITIES AND ACCREDITATIONS**

### **5.1 FACILITIES**

All measurement facilities used to collect the measurement data are located at

No. 8, Jiu Cheng Ling, Jiaokeng Village, Sinhua Township, Tainan Hsien 712, Taiwan R.O.C.

The sites are constructed in conformance with the requirements of ANSI C63.4 and CISPR Publication 22.

### **5.2 EQUIPMENT**

Radiated emissions are measured with one or more of the following types of linearly polarized antennas: tuned dipole, biconical, log periodic, bi-log, and/or ridged waveguide, horn. Spectrum analyzers with preselectors and quasi-peak detectors are used to perform radiated measurements.

Conducted emissions are measured with Line Impedance Stabilization Networks and EMI Test Receivers.







Calibrated wideband preamplifiers, coaxial cables, and coaxial attenuators are also used for making measurements.

All receiving equipment conforms to CISPR Publication 16-1, "Radio Interference Measuring Apparatus and Measurement Methods."

### **5.3 LABORATORY ACCREDITATIONS LISTINGS**

The test facilities used to perform radiated and conducted emissions tests are accredited by Taiwan Accreditation Foundation for the specific scope of accreditation under Lab Code: 1109 to perform Electromagnetic Interference tests according to FCC PART 15 AND CISPR 22 requirements. In addition, the test facilities are listed with Industry Canada, Certification and Engineering Bureau, IC 2324H-1 for OATS -6.

### 5.4 TABLE OF ACCREDITATIONS AND LISTINGS

Country	Agency	Scope of Accreditation	Logo
USA	FCC	3/10 meter Open Area Test Sites to perform FCC Part 15/18 measurements	 FCC MRA: TW-1037
Japan	VCCI	3/10 meter Open Area Test Sites to perform conducted/radiated measurements	 C-2882 R-2635
Taiwan	TAF	CISPR 11, FCC METHOD-47 CFR Part 18, EN 55011, EN 60601-1-2, CISPR 22, CNS 13438, EN 55022, EN 55024, AS/NZS CISPR 22 CISPR 14, EN 55014-1, EN 55014-2, CNS 13783-1, CISPR 22, CNS 13439, EN 55013, FCC Method-47 CFR Part 15 Subpart B, IC ICES-003, VCCI V-3 & V-4 FCC Method-47 CFR Part 15 Subpart C and ANSI C63.4, LP 0002 EN / IEC 61000-4-2 / -3 / -4 / -5 / -6 / -8 / -11 EN 61000-3-2, EN 61000-3-3 EN 61000-6-3, EN 61000-6-1, AS/NZS 4251.1, EN 61000-6-4, EN 61000-6-2, AS/NZS 4251.2, EN 61204-3, EN 50130-4, EN 62040-2, EN 50371, EN 50385, AS/NZS 4268, ETSI EN 300 386 ETSI EN 300 328, ETSI EN 301 489-1/-3/-9/-17 ETSI EN 301 893, ETSI EN 300 220-2/-1 ETSI EN 300 440-2/-1 ETSI EN 301 357-2/-1 RSS-310, RSS-210 Issue 7, RSS-Gen Issue 2	 
Taiwan	BSMI	CNS 13438, CNS 13783-1, CNS13439	 SL2-IN-E-0039 SL2-R1/R2-0039 SL2-A1-E-0039
Canada	Industry Canada	RSS210, Issue 7	 IC 2324H-1

\* No part of this report may be used to claim or imply product endorsement by TAF or any agency of the US Government.





## 6. CALIBRATION AND UNCERTAINTY

### 6.1 MEASURING INSTRUMENT CALIBRATION

The measuring equipment utilized to perform the tests documented in this report has been calibrated in accordance with the manufacturer's recommendations, and is traceable to recognized national standards.

### 6.2 MEASUREMENT UNCERTAINTY

The following table is for the measurement uncertainty, which is calculated as per the document CISPR 16-4.

PARAMETER	UNCERTAINTY
Radiated Emission, 30 to 1000 MHz	+/- 3.2 dB
Radiated Emission, 1 to 26.5GHz	+/- 3.2 dB
Power Line Conducted Emission	+/- 2.1 dB

This uncertainty represents an expanded uncertainty expressed at approximately the 95% confidence level using a coverage factor of k=2.



## 7. SETUP OF EQUIPMENT UNDER TEST

### SUPPORT EQUIPMENT

No.	Product	Manufacturer	Model No.	Serial No.	FCC ID
1	Wireless Communications Test Set	AGILENT	8960	MY48361017	---
2	Notebook PC	Lenovo ideaPad	S10e_4068-RZ1	L3CEV2D	HFS-FL
3	Notebook PC	HP	nx6130	CNU543274R	CNTWM3B2200B GA
4	Bluetooth Headset	Motorola	H17	SJYN029A	IHDP6KE1
5	Modem	ZyXEL	Omni 56K	S1Z4107727	1880MNI56K
6	Modem	ZyXEL	Omni 56K	S1Z4107729	1880MNI56K
7	Monitor	DELL	2407WFPb	CN-0FC255-46633 -6CP-06JS	---
8	Headset/Microphone	ERGOTECH	ET-E203	4719405008042	---
9	Flash disk	SanDisk	SDCZ6-1024	BB0706I6B	---
10	Flash disk	Transcend	CompactFlash512MB	1561433338	-----
11	Flash disk	Sayho	PR1014(256M)	104720	---
12	Flash disk	SanDisk	SDSDM-1024	BB07251CTE	-----
13	Usb Flash disk	Transcend	Jet Flash V10(4G)	258909 0093	---
14	Usb Flash disk	Transcend	Jet Flash V10(4G)	258909 0094	---
15	CardReader Expresscard	UPTECH	UTE600	169170022	---
16	PCMCIA Card	Billionton	---	00082900065	---

	Signal Cable	Description
1	RJ-45 cable	Shielded 12m ×1
2	RJ-11 cable	Unshielded 12m ×1



## **SETUP DIAGRAM FOR TESTS**

EUT & peripherals setup diagram is shown in appendix setup photos.

## **EUT OPERATING CONDITION**

An executive program, "EMITEST.exe" under Win XP, which generates a complete line of continuously repeating "H" pattern was used as the test software.

1. Setup all computers like the setup diagram.
2. All of the functions are under run.
3. The EUT reads the test program from the hard disk drive and run it.
4. The EUT sends "H" messages to the monitor, and the monitor displays "H" patterns on the screen.
5. The EUT sends "H" messages to the internal hard disk, and the hard disk reads and writes the message.
6. Repeat the steps from 4 to 5.
7. At the same time, the following programs were executed.
8. Executed "Windows Media Player" to play music via Bluetooth headset.
9. Executed "Winthrax.exe" to read/write data from external USB 2.0 devices.
10. Executed "ping.exe" to link with the remote workstation to receive and transmit data via RJ45 cable.
11. Executed "Hyper Terminal.exe" to link with the remote workstation to receive and transmit data by RJ11 cable.
12. Executed "Bluetooth" to link with the remote workstation to receive and transmit data with Bluetooth Headset.
13. Start test.



## 8. APPLICABLE LIMITS AND TEST RESULTS

### 8.1 RADIATED EMISSIONS

#### 8.1.1 TRANSMITTER RADIATED SUPURIOUS EMSSIONS

##### LIMITS

§ 15.205 (a) Except as shown in paragraph (d) of this section, only spurious emissions are permitted in any of the frequency bands listed below:

MHz	MHz	MHz	GHz
0.090 - 0.110	16.42 - 16.423	399.9 - 410	4.5 - 5.15
<sup>1</sup> 0.495 - 0.505	16.69475 - 16.69525	608 - 614	5.35 - 5.46
2.1735 - 2.1905	16.80425 - 16.80475	960 - 1240	7.25 - 7.75
4.125 - 4.128	25.5 - 25.67	1300 - 1427	8.025 - 8.5
4.17725 - 4.17775	37.5 - 38.25	1435 - 1626.5	9.0 - 9.2
4.20725 - 4.20775	73 - 74.6	1645.5 - 1646.5	9.3 - 9.5
6.215 - 6.218	74.8 - 75.2	1660 - 1710	10.6 - 12.7
6.26775 - 6.26825	108 - 121.94	1718.8 - 1722.2	13.25 - 13.4
6.31175 - 6.31225	123 - 138	2200 - 2300	14.47 - 14.5
8.291 - 8.294	149.9 - 150.05	2310 - 2390	15.35 - 16.2
8.362 - 8.366	156.52475 - 156.52525	2483.5 - 2500	17.7 - 21.4
8.37625 - 8.38675	156.7 - 156.9	2655 - 2900	22.01 - 23.12
8.41425 - 8.41475	162.0125 - 167.17	3260 - 3267	23.6 - 24.0
12.29 - 12.293	167.72 - 173.2	3332 - 3339	31.2 - 31.8
12.51975 - 12.52025	240 - 285	3345.8 - 3338	36.43 - 36.5
12.57675 - 12.57725	322 - 335.4	3600 - 4400	( <sup>2</sup> )
13.36 - 13.41			

<sup>1</sup> Until February 1, 1999, this restricted band shall be 0.490-0.510 MHz.

<sup>2</sup> Above 38.6

§ 15.205 (b) Except as provided in paragraphs (d) and (e), the field strength of emissions appearing within these frequency bands shall not exceed the limits shown in Section 15.209. At frequencies equal to or less than 1000 MHz, compliance with the limits in Section 15.209 shall be demonstrated using measurement instrumentation employing a CISPR quasi-peak detector. Above 1000 MHz, compliance with the emission limits in Section 15.209 shall be demonstrated based on the average value of the measured emissions. The provisions in Section 15.35 apply to these measurements.



§ 15.209 (a) Except as provided elsewhere in this Subpart, the emissions from an intentional radiator shall not exceed the field strength levels specified in the following table :

Frequency (MHz)	Field Strength (microvolts/meter)	Measurement Distance (meters)
30 - 88	100 **	3
88 - 216	150 **	3
216 - 960	200 **	3
Above 960	500	3

\*\* Except as provided in paragraph (g), fundamental emissions from intentional radiators operating under this Section shall not be located in the frequency bands 54-72 MHz, 76-88 MHz, 174-216 MHz or 470-806 MHz, However, operation within these frequency bands is permitted under other sections of this Part, e-g, Sections 15.231 and 15.241 .

§ 15.209 (b) In the emission table above, the tighter limit applies at the band edges.

### **TEST EQUIPMENT**

Name of Equipment	Manufacturer	Model	Serial Number	Calibration Due
SPECTRUM ANALYZER	AGILENT	E4446A	MY43360132	06/09/2010
SPECTRUM ANALYZER	AGILENT	E4446A	MY46180323	05/26/2010
EMI TEST RECEIVER	R & S	ESCI	100221	05/17/2010
BILOG ANTENNA	SCHWARZBECK	VULB	9168_249	09/17/2010
Double-Ridged Waveguide Horn	ETS LINDGREN	3117	00078732	06/30/2010
PRE-AMPLIFIER	Agilent	8449B	3008A01471	08/02/2010
PRE-AMPLIFIER	HP	8447F	2944A03748	09/24/2010
Notch Filters Band Reject	Micro-Tronics	BRM50702-01	009	N.C.R.
Band Reject Filter	Micro-Tronics	BRC50703-01	004	N.C.R.
Band Reject Filter	Micro-Tronics	BRC50704-01	004	N.C.R.
Band Reject Filter	Micro-Tronics	BRC50705-01	007	N.C.R.
RF COAXIAL CABLE	HUBERSUHNER	SUCOFLEX 104PEA	SN31350	07/21/2010

**Remark:** 1. Each piece of equipment is scheduled for calibration once a year.

2. N.C.R = No Calibration Request.

## TEST SETUP

The diagram below shows the test setup that is utilized to make the measurements for emission from below 1GHz.

### 9kHz ~ 30MHz

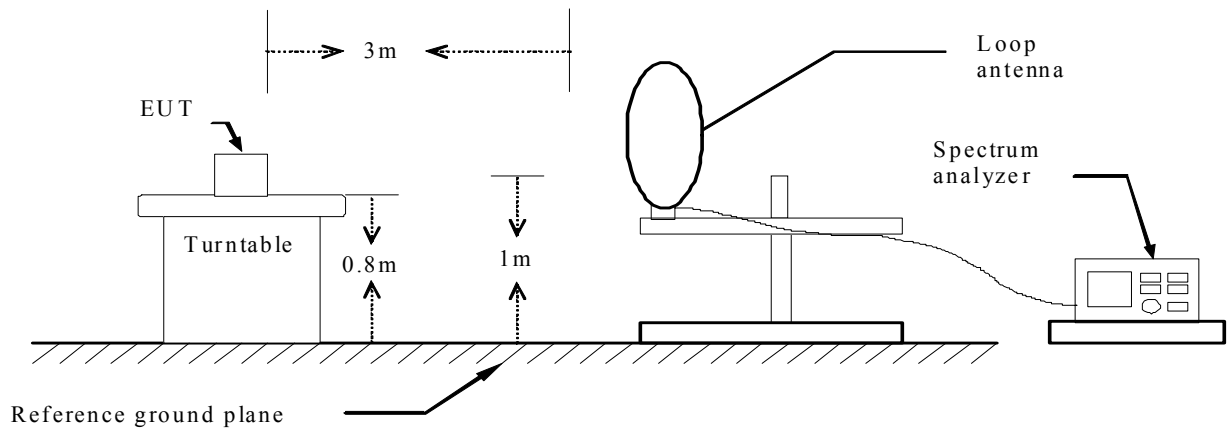

### 30MHz ~ 1GHz

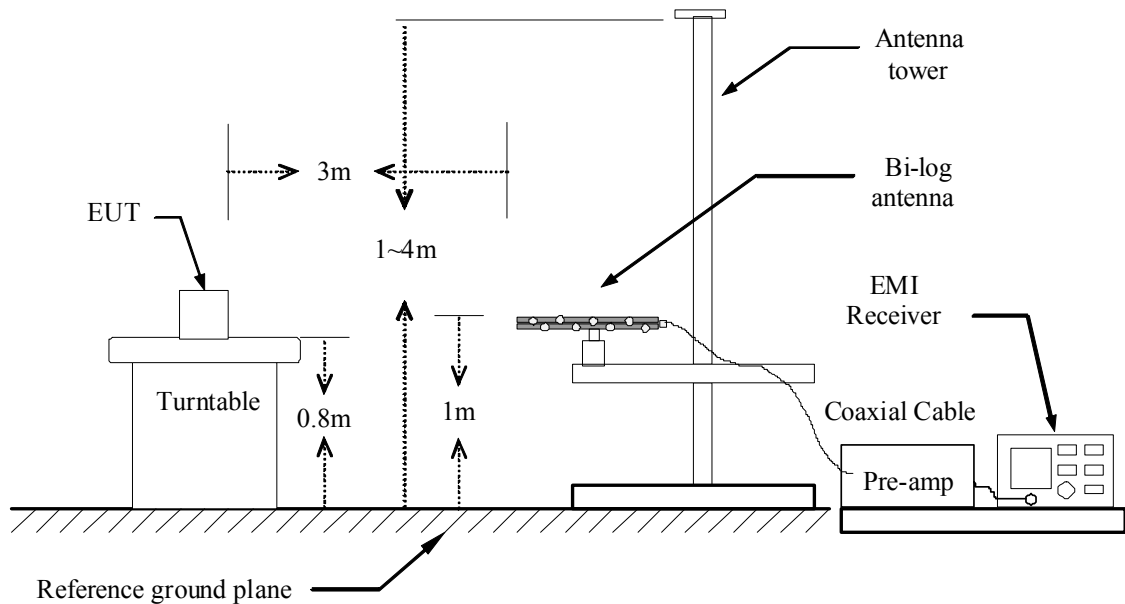

The diagram below shows the test setup that is utilized to make the measurements for emission above 1GHz.

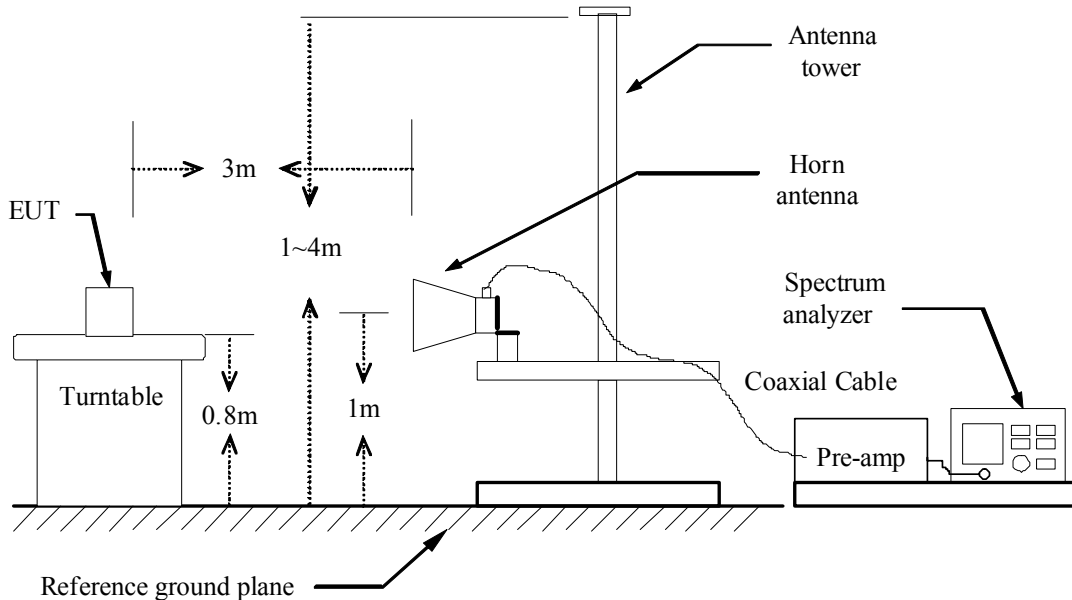

### **TEST PROCEDURE**

- a. The EUT was placed on the top of a rotating table 0.8 meters above the ground at a 10 meter open area test site. The table was rotated 360 degrees to determine the position of the highest radiation.
- b. While measuring the radiated emission below 1GHz, the EUT was set 3 meters away from the interference-receiving antenna, which was mounted on the top of a variable-height antenna tower. While measuring the radiated emission above 1GHz, the EUT was set 3 meters away from the interference-receiving antenna
- c. The antenna is a broadband antenna, and its height is varied from one meter to four meters above the ground to determine the maximum value of the field strength. Both horizontal and vertical polarization of the antenna are set to make the measurement.
- d. For each suspected emission, the EUT was arranged to its worst case and then the antenna was tuned to heights from 1 meter to 4 meters and the table was turned from 0 degrees to 360 degrees to find the maximum reading.
- e. The test-receiver system was set to Peak Detect Function and Specified Bandwidth with Maximum Hold Mode.
- f. If the emission level of the EUT in peak mode was 10 dB lower than the limit specified, then testing could be stopped and the peak values of the EUT would be reported. Otherwise the emissions that did not have 10 dB margin would be re-tested one by one using peak, quasi-peak or average method as specified and then reported in a data sheet.

Note :

1. The resolution bandwidth and video bandwidth of test receiver/spectrum analyzer is 120 KHz for Peak detection (PK) and Quasi-peak detection (QP) at frequency below 1GHz.
2. The resolution bandwidth and video bandwidth of test receiver/spectrum analyzer is 1 MHz for Peak detection and frequency above 1GHz.
3. The resolution bandwidth of test receiver/spectrum analyzer is 1 MHz and the video bandwidth is 10 Hz for Average detection (AV) at frequency above 1GHz.

**8.1.2 WORST-CASE RADIATED EMISSION BELOW 1 GHz****BELOW 1 GHz (9kHz ~ 30MHz)**

No emission found between lowest internal used/generated frequency to 30MHz.

**BELOW 1 GHz (30MHz ~ 1GHz)**

<b>Product Name</b>	BLUETOOTH MODULE	<b>Test Date</b>	2009/10/28
<b>Model</b>	GUBTCR42M	<b>Test By</b>	Rick Lin
<b>Test Mode</b>	Normal operating / EMC-1 Power Adapter (1)	<b>TEMP &amp; Humidity</b>	25.2°C, 58%

<b>966 Chamber at 3Meter / Horizontal</b>						
Frequency (MHz)	Reading (dBμV)	Correction Factor (dB/m)	Result (dBμV/m)	Limit (dBμV/m)	Margin (dB)	Remark
77.53	48.06	-14.46	33.61	40.00	-6.39	Peak
166.77	49.21	-10.32	38.89	43.50	-4.61	Peak
276.38	46.32	-9.61	36.70	46.00	-9.30	Peak
400.54	44.00	-5.87	38.13	46.00	-7.87	QP
480.08	41.87	-4.05	37.82	46.00	-8.18	Peak
749.74	37.32	1.33	38.65	46.00	-7.35	Peak
960.23	45.50	4.75	50.25	54.00	-3.75	Peak
<b>966 Chamber at 3Meter / Vertical</b>						
Frequency (MHz)	Reading (dBμV)	Correction Factor (dB/m)	Result (dBμV/m)	Limit (dBμV/m)	Margin (dB)	Remark
56.19	46.60	-10.45	36.15	40.00	-3.85	QP
65.89	51.20	-11.65	39.55	40.00	-0.45	QP
398.60	43.80	-5.93	37.87	46.00	-8.13	QP
480.08	44.06	-4.05	40.01	46.00	-5.99	Peak
839.95	38.35	2.66	41.01	46.00	-4.99	Peak
900.09	38.66	3.85	42.51	46.00	-3.49	Peak
960.23	39.52	4.75	44.27	54.00	-9.73	Peak

**Remark:**

1. Quasi-peak test would be performed if the peak result were greater than the quasi-peak limit.
2. Data of measurement within this frequency range shown " --- " in the table above means the reading of emissions are attenuated more than 20dB below the permissible limits or the field strength is too small to be measured.
3. Correction Factor (dB/m) = Antenna Factor (dB/m) + Cable Loss (dB) – PreAmp.Gain (dB)
4. Result (dBuV/m) = Reading (dBuV) + Correction Factor (dB/m)
5. Margin (dB) = Remark result (dBuV/m) - Quasi-peak limit (dBuV/m).





<b>Product Name</b>	BLUETOOTH MODULE	<b>Test Date</b>	2009/10/29
<b>Model</b>	GUBTCR42M	<b>Test By</b>	Rick Lin
<b>Test Mode</b>	Normal operating / EMC-1 Power Adapter (2)	<b>TEMP &amp; Humidity</b>	27°C, 57%

966 Chamber at 3Meter / Horizontal						
Frequency (MHz)	Reading (dBμV)	Correction Factor (dB/m)	Result (dBμV/m)	Limit (dBμV/m)	Margin (dB)	Remark
64.92	41.32	-11.53	29.79	40.00	-10.21	Peak
120.21	50.90	-12.78	38.11	43.50	-5.39	Peak
144.46	43.28	-10.47	32.81	43.50	-10.69	Peak
166.77	49.58	-10.32	39.26	43.50	-4.24	Peak
276.38	47.35	-9.61	37.74	46.00	-8.26	Peak
400.54	47.40	-5.87	41.53	46.00	-4.47	QP
960.23	35.55	4.75	40.30	54.00	-13.70	Peak
966 Chamber at 3Meter / Vertical						
Frequency (MHz)	Reading (dBμV)	Correction Factor (dB/m)	Result (dBμV/m)	Limit (dBμV/m)	Margin (dB)	Remark
39.70	46.80	-10.50	36.30	40.00	-3.70	QP
50.37	46.40	-9.76	36.64	40.00	-3.36	Peak
65.89	50.05	-11.65	38.40	40.00	-1.60	QP
77.53	50.75	-14.46	36.30	40.00	-3.70	Peak
166.77	50.20	-10.32	39.88	43.50	-3.62	QP
276.38	47.64	-9.61	38.02	46.00	-7.98	Peak
399.57	44.20	-5.90	38.30	46.00	-7.70	QP

**Remark:**

1. Quasi-peak test would be performed if the peak result were greater than the quasi-peak limit.
2. Data of measurement within this frequency range shown " --- " in the table above means the reading of emissions are attenuated more than 20dB below the permissible limits or the field strength is too small to be measured.
3. Correction Factor (dB/m) = Antenna Factor (dB/m) + Cable Loss (dB) – PreAmp.Gain (dB)
4. Result (dBμV/m) = Reading (dBμV) + Correction Factor (dB/m)
5. Margin (dB) = Remark result (dBμV/m) - Quasi-peak limit (dBμV/m).



<b>Product Name</b>	BLUETOOTH MODULE	<b>Test Date</b>	2009/10/30
<b>Model</b>	GUBTCR42M	<b>Test By</b>	Rick Lin
<b>Test Mode</b>	Normal operating / EMC-2 Power Adapter (1)	<b>TEMP &amp; Humidity</b>	27°C, 57%

966 Chamber at 3Meter / Horizontal						
Frequency (MHz)	Reading (dBμV)	Correction Factor (dB/m)	Result (dBμV/m)	Limit (dBμV/m)	Margin (dB)	Remark
99.84	46.97	-15.27	31.70	43.50	-11.80	Peak
276.38	44.40	-9.61	34.78	46.00	-11.22	Peak
400.54	46.89	-5.87	41.02	46.00	-4.98	Peak
719.67	34.95	0.59	35.54	46.00	-10.46	Peak
798.24	37.21	1.92	39.13	46.00	-6.87	Peak
902.03	34.68	3.88	38.56	46.00	-7.44	Peak
960.23	35.70	4.75	40.44	54.00	-13.56	Peak
966 Chamber at 3Meter / Vertical						
Frequency (MHz)	Reading (dBμV)	Correction Factor (dB/m)	Result (dBμV/m)	Limit (dBμV/m)	Margin (dB)	Remark
30.97	49.09	-12.61	36.48	40.00	-3.52	Peak
42.61	45.00	-10.13	34.87	40.00	-5.13	QP
55.22	45.56	-10.33	35.23	40.00	-4.77	Peak
64.92	49.60	-11.53	38.07	40.00	-1.93	QP
75.59	48.98	-13.87	35.11	40.00	-4.89	Peak
399.57	45.60	-5.90	39.70	46.00	-6.30	QP
799.21	38.08	1.93	40.01	46.00	-5.99	Peak

**Remark:**

1. Quasi-peak test would be performed if the peak result were greater than the quasi-peak limit.
2. Data of measurement within this frequency range shown " --- " in the table above means the reading of emissions are attenuated more than 20dB below the permissible limits or the field strength is too small to be measured.
3. Correction Factor (dB/m) = Antenna Factor (dB/m) + Cable Loss (dB) – PreAmp.Gain (dB)
4. Result (dBμV/m) = Reading (dBμV) + Correction Factor (dB/m)
5. Margin (dB) = Remark result (dBμV/m) - Quasi-peak limit (dBμV/m).



<b>Product Name</b>	BLUETOOTH MODULE	<b>Test Date</b>	2009/10/30
<b>Model</b>	GUBTCR42M	<b>Test By</b>	Rick Lin
<b>Test Mode</b>	Normal operating / EMC-2 Power Adapter (2)	<b>TEMP &amp; Humidity</b>	27°C, 57%

966 Chamber at 3Meter / Horizontal						
Frequency (MHz)	Reading (dBμV)	Correction Factor (dB/m)	Result (dBμV/m)	Limit (dBμV/m)	Margin (dB)	Remark
144.46	40.90	-10.47	30.43	43.50	-13.07	Peak
233.70	44.23	-11.51	32.72	46.00	-13.28	Peak
276.38	43.47	-9.61	33.86	46.00	-12.14	Peak
300.63	43.73	-8.83	34.90	46.00	-11.10	Peak
399.57	48.00	-5.90	42.10	46.00	-3.90	Peak
802.12	36.12	1.97	38.09	46.00	-7.91	Peak
960.23	38.22	4.75	42.97	54.00	-11.03	Peak
966 Chamber at 3Meter / Vertical						
Frequency (MHz)	Reading (dBμV)	Correction Factor (dB/m)	Result (dBμV/m)	Limit (dBμV/m)	Margin (dB)	Remark
42.61	47.07	-10.13	36.94	40.00	-3.06	Peak
56.19	46.90	-10.45	36.45	40.00	-3.55	Peak
64.92	47.20	-11.53	35.67	40.00	-4.33	QP
77.53	51.10	-14.46	36.64	40.00	-3.36	QP
99.84	50.89	-15.27	35.62	43.50	-7.88	Peak
399.57	45.80	-5.90	39.90	46.00	-6.10	QP
802.12	38.35	1.97	40.32	46.00	-5.68	Peak

**Remark:**

1. Quasi-peak test would be performed if the peak result were greater than the quasi-peak limit.
2. Data of measurement within this frequency range shown " --- " in the table above means the reading of emissions are attenuated more than 20dB below the permissible limits or the field strength is too small to be measured.
3. Correction Factor (dB/m) = Antenna Factor (dB/m) + Cable Loss (dB) – PreAmp.Gain (dB)
4. Result (dBμV/m) = Reading (dBμV) + Correction Factor (dB/m)
5. Margin (dB) = Remark result (dBμV/m) - Quasi-peak limit (dBμV/m).



<b>Product Name</b>	BLUETOOTH MODULE	<b>Test Date</b>	2009/10/26
<b>Model</b>	GUBTCR42M	<b>Test By</b>	Rick Lin
<b>Test Mode</b>	Normal operating / EMC-3 Power Adapter (1)	<b>TEMP &amp; Humidity</b>	22.3°C, 56%

966 Chamber at 3Meter / Horizontal						
Frequency (MHz)	Reading (dBμV)	Correction Factor (dB/m)	Result (dBμV/m)	Limit (dBμV/m)	Margin (dB)	Remark
206.54	52.68	-12.62	40.07	43.50	-3.43	Peak
243.40	51.55	-10.82	40.73	46.00	-5.27	Peak
319.06	48.62	-8.30	40.32	46.00	-5.68	Peak
399.57	47.89	-5.90	41.99	46.00	-4.01	Peak
719.67	41.99	0.59	42.58	46.00	-3.42	Peak
900.09	36.47	3.85	40.32	46.00	-5.68	Peak
960.23	42.30	4.75	47.05	54.00	-6.95	QP
966 Chamber at 3Meter / Vertical						
Frequency (MHz)	Reading (dBμV)	Correction Factor (dB/m)	Result (dBμV/m)	Limit (dBμV/m)	Margin (dB)	Remark
30.97	49.84	-12.61	37.23	40.00	-2.77	Peak
56.19	48.00	-10.45	37.55	40.00	-2.45	QP
152.22	46.39	-10.10	36.29	43.50	-7.21	Peak
400.54	47.88	-5.87	42.01	46.00	-3.99	Peak
524.70	41.68	-3.20	38.48	46.00	-7.52	Peak
719.67	38.76	0.59	39.35	46.00	-6.65	Peak
933.07	35.63	4.35	39.98	46.00	-6.02	Peak

**Remark:**

1. Quasi-peak test would be performed if the peak result were greater than the quasi-peak limit.
2. Data of measurement within this frequency range shown " --- " in the table above means the reading of emissions are attenuated more than 20dB below the permissible limits or the field strength is too small to be measured.
3. Correction Factor (dB/m) = Antenna Factor (dB/m) + Cable Loss (dB) – PreAmp.Gain (dB)
4. Result (dBμV/m) = Reading (dBμV) + Correction Factor (dB/m)
5. Margin (dB) = Remark result (dBμV/m) - Quasi-peak limit (dBμV/m).



<b>Product Name</b>	BLUETOOTH MODULE	<b>Test Date</b>	2009/10/30
<b>Model</b>	GUBTCR42M	<b>Test By</b>	Rick Lin
<b>Test Mode</b>	Normal operating / EMC-3 Power Adapter (2)	<b>TEMP &amp; Humidity</b>	27°C, 57%

966 Chamber at 3Meter / Horizontal						
Frequency (MHz)	Reading (dBμV)	Correction Factor (dB/m)	Result (dBμV/m)	Limit (dBμV/m)	Margin (dB)	Remark
56.19	40.64	-10.45	30.19	40.00	-9.81	Peak
120.21	48.10	-12.78	35.31	43.50	-8.19	Peak
206.54	53.30	-12.62	40.68	43.50	-2.82	QP
243.40	51.08	-10.82	40.26	46.00	-5.74	Peak
319.06	49.24	-8.30	40.93	46.00	-5.07	Peak
400.54	47.39	-5.87	41.52	46.00	-4.48	Peak
960.23	37.77	4.75	42.51	54.00	-11.49	Peak
966 Chamber at 3Meter / Vertical						
Frequency (MHz)	Reading (dBμV)	Correction Factor (dB/m)	Result (dBμV/m)	Limit (dBμV/m)	Margin (dB)	Remark
43.58	44.20	-10.01	34.19	40.00	-5.81	QP
56.19	47.31	-10.45	36.87	40.00	-3.13	Peak
64.92	48.40	-11.53	36.87	40.00	-3.13	QP
168.71	46.11	-10.49	35.62	43.50	-7.88	Peak
206.54	48.33	-12.62	35.71	43.50	-7.79	Peak
243.40	48.38	-10.82	37.56	46.00	-8.44	Peak
400.54	46.36	-5.87	40.50	46.00	-5.50	Peak

**Remark:**

1. Quasi-peak test would be performed if the peak result were greater than the quasi-peak limit.
2. Data of measurement within this frequency range shown " --- " in the table above means the reading of emissions are attenuated more than 20dB below the permissible limits or the field strength is too small to be measured.
3. Correction Factor (dB/m) = Antenna Factor (dB/m) + Cable Loss (dB) – PreAmp.Gain (dB)
4. Result (dBμV/m) = Reading (dBμV) + Correction Factor (dB/m)
5. Margin (dB) = Remark result (dBμV/m) - Quasi-peak limit (dBμV/m).



## 8.2 POWERLINE CONDUCTED EMISSIONS

### LIMITS

§ 15.207 (a) Except as shown in paragraph (b) and (c) this section, for an intentional radiator that is designed to be connected to the public utility (AC) power line, the radio frequency voltage that is conducted back onto the AC power line on any frequency or frequencies within the band 150 kHz to 30 MHz shall not exceed the limits in the following table, as measured using a 50  $\mu$ H/50 ohms line impedance stabilization network (LISN). Compliance with the provisions of this paragraph shall be based on the measurement of the radio frequency voltage between each power line and ground at the power terminal.

The lower limit applies at the boundary between the frequency ranges.

Frequency of Emission (MHz)	Conducted limit (dB $\mu$ v)	
	Quasi-peak	Average
0.15 - 0.5	66 to 56	56 to 46
0.5 - 5	56	46
5 - 30	60	50

### TEST EQUIPMENT

Name of Equipment	Manufacturer	Model	Serial Number	Calibration Due
L.I.S.N	SCHWARZBECK	NSLK 8127	8127-465	08/13/2010
TEST RECEIVER	R & S	ESHS 30	838550/003	02/02/2010
TEST RECEIVER	R & S	ESCS 30	826547/004	08/05/2010
PULSE LIMIT	R & S	ESH3-Z2	100117	09/17/2010
N TYPE COAXIAL CABLE	BELDEN	8268 M17/164	003	07/09/2010

*Remark: Each piece of equipment is scheduled for calibration once a year.*

**TEST SETUP**

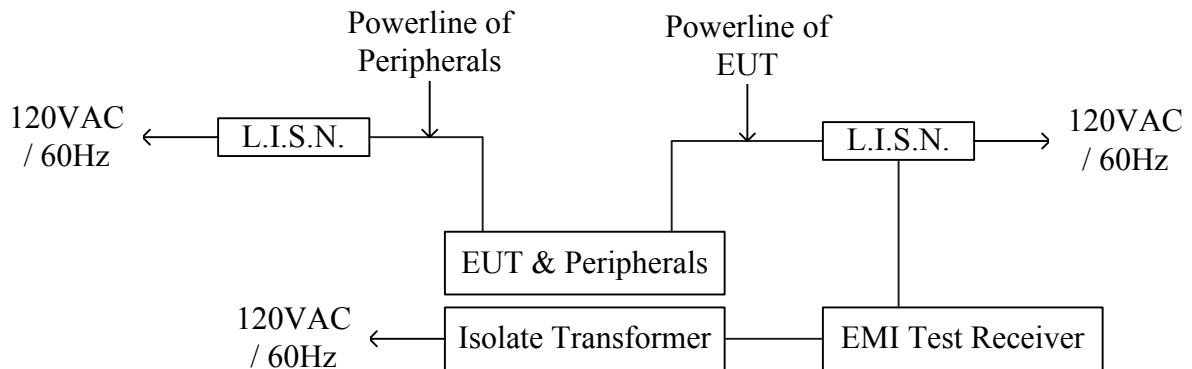
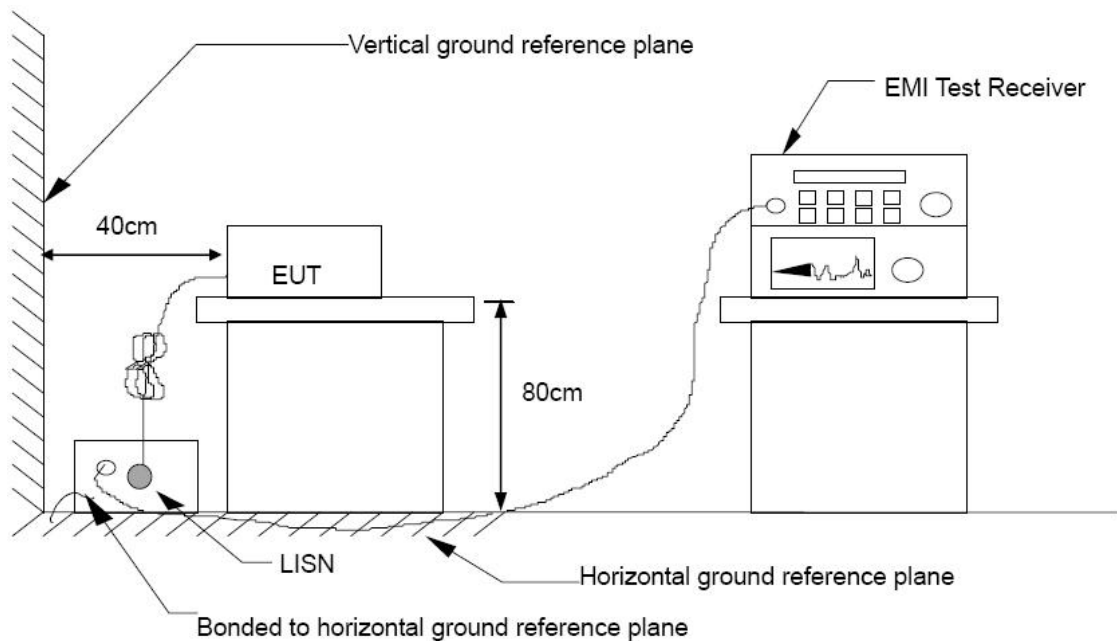

**TEST PROCEDURE**

The test procedure is performed in a 4m × 3m × 2.4m(L×W×H) shielded room.

The EUT along with its peripherals were placed on a 1.0m(W)× 1.5m(L) and 0.8m in height wooden table and the EUT was adjusted to maintain a 0.4 meter space from a vertical reference plane. The EUT was connected to power mains through a line impedance stabilization network (LISN) which provides 50 ohm coupling impedance for measuring instrument and the chassis ground was bounded to the horizontal ground plane of shielded room. All peripherals were connected to the second LISN and the chassis ground also bounded to the horizontal ground plane of shielded room. The excess power cable between the EUT and the LISN was bundled. The power cables of peripherals were unbundled. All connecting cables of EUT and peripherals were moved to find the maximum emission.



**TEST RESULTS**

<b>Product Name</b>	BLUETOOTH MODULE	<b>Test Date</b>	2009/10/29
<b>Model Name</b>	GUBTCR42M	<b>Test By</b>	Rick Lin
<b>Test Mode</b>	Normal operating / EMC-1 Power Adapter (1)	<b>TEMP &amp; Humidity</b>	24.4°C, 71%

LINE

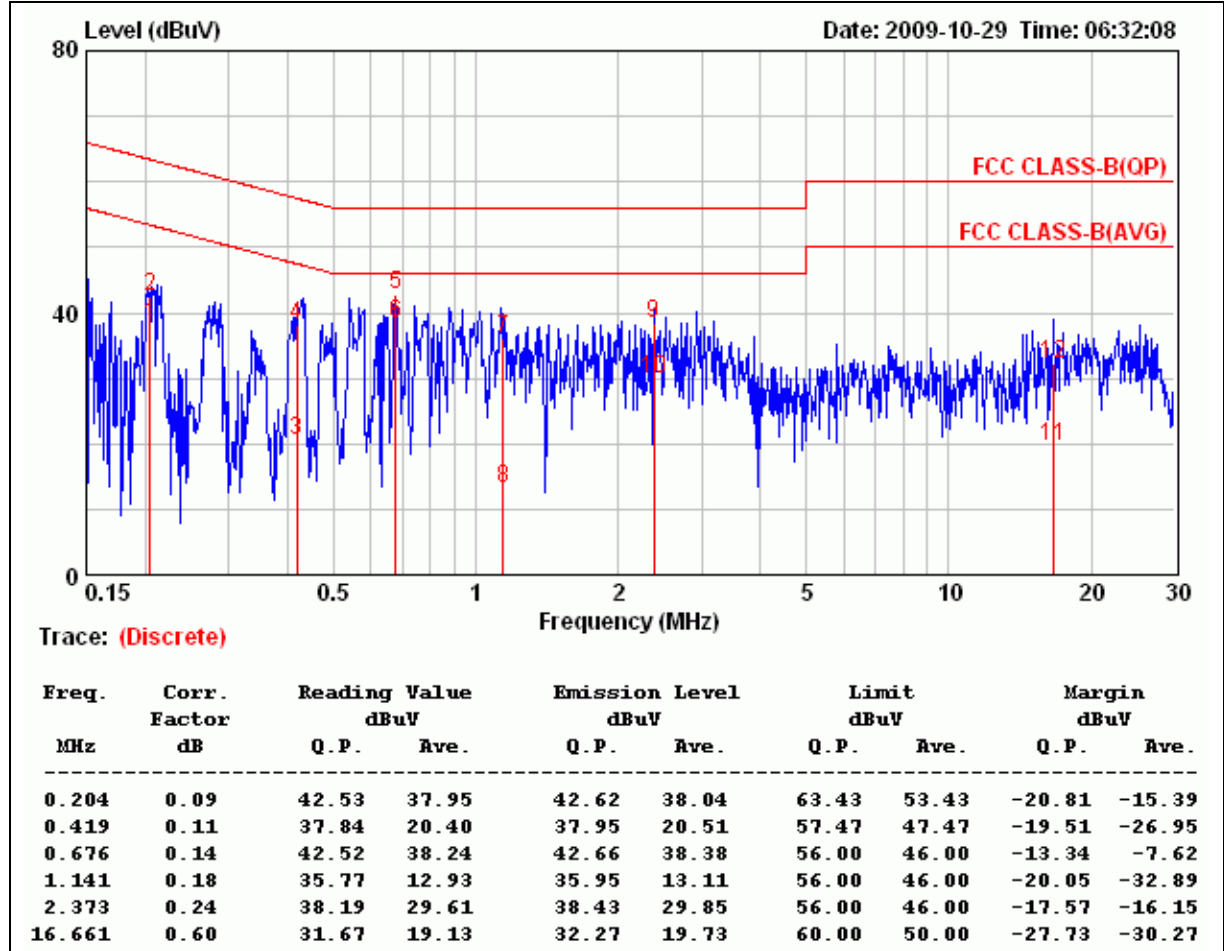

**Remark:**

1. Correction Factor = Insertion loss + cable loss
2. Margin value = Emission level – Limit value





<b>Product Name</b>	BLUETOOTH MODULE	<b>Test Date</b>	2009/10/29
<b>Model Name</b>	GUBTCR42M	<b>Test By</b>	Rick Lin
<b>Test Mode</b>	Normal operating / EMC-1 Power Adapter (1)	<b>TEMP &amp; Humidity</b>	24.4°C, 71%

NEUTRAL

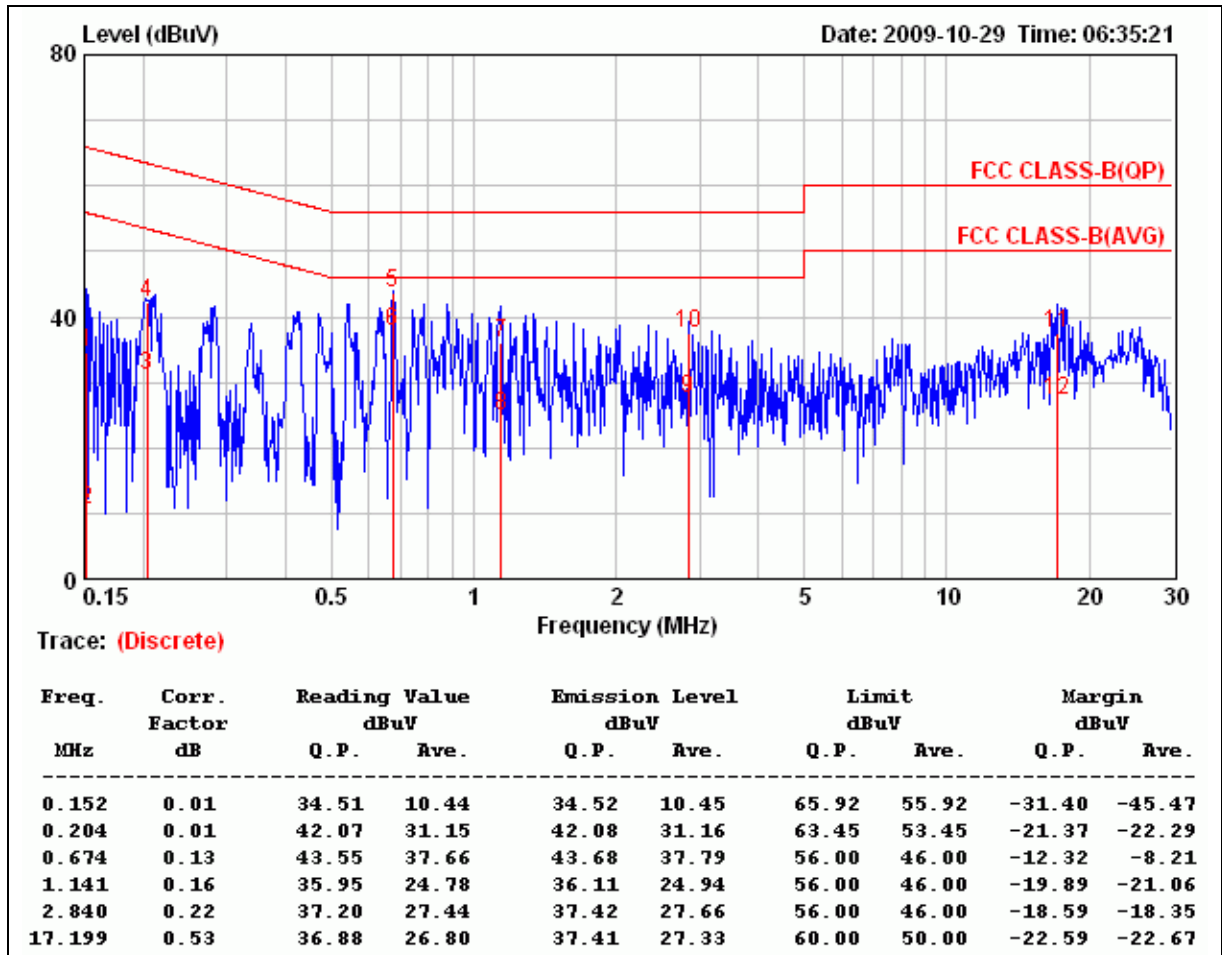

Remark:

1. Correction Factor = Insertion loss + cable loss
2. Margin value = Emission level – Limit value



<b>Product Name</b>	BLUETOOTH MODULE	<b>Test Date</b>	2009/10/30
<b>Model Name</b>	GUBTCR42M	<b>Test By</b>	Joe Peng
<b>Test Mode</b>	Normal operating / EMC-1 Power Adapter (2)	<b>TEMP &amp; Humidity</b>	24.4°C, 71%

LINE

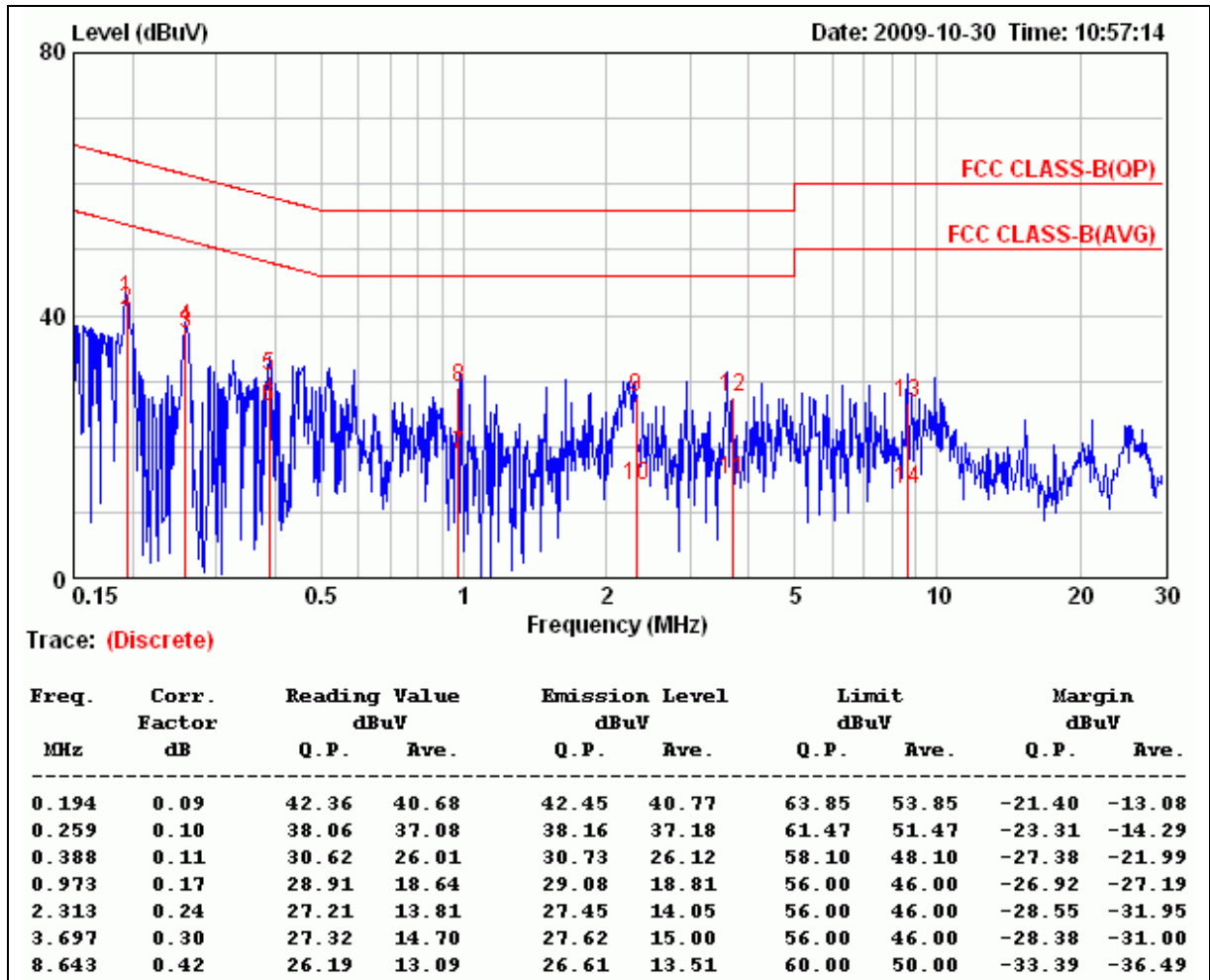

Remark:

1. Correction Factor = Insertion loss + cable loss
2. Margin value = Emission level – Limit value



<b>Product Name</b>	BLUETOOTH MODULE	<b>Test Date</b>	2009/10/30
<b>Model Name</b>	GUBTCR42M	<b>Test By</b>	Joe Peng
<b>Test Mode</b>	Normal operating / EMC-1 Power Adapter (2)	<b>TEMP &amp; Humidity</b>	24.4°C, 71%

NEUTRAL

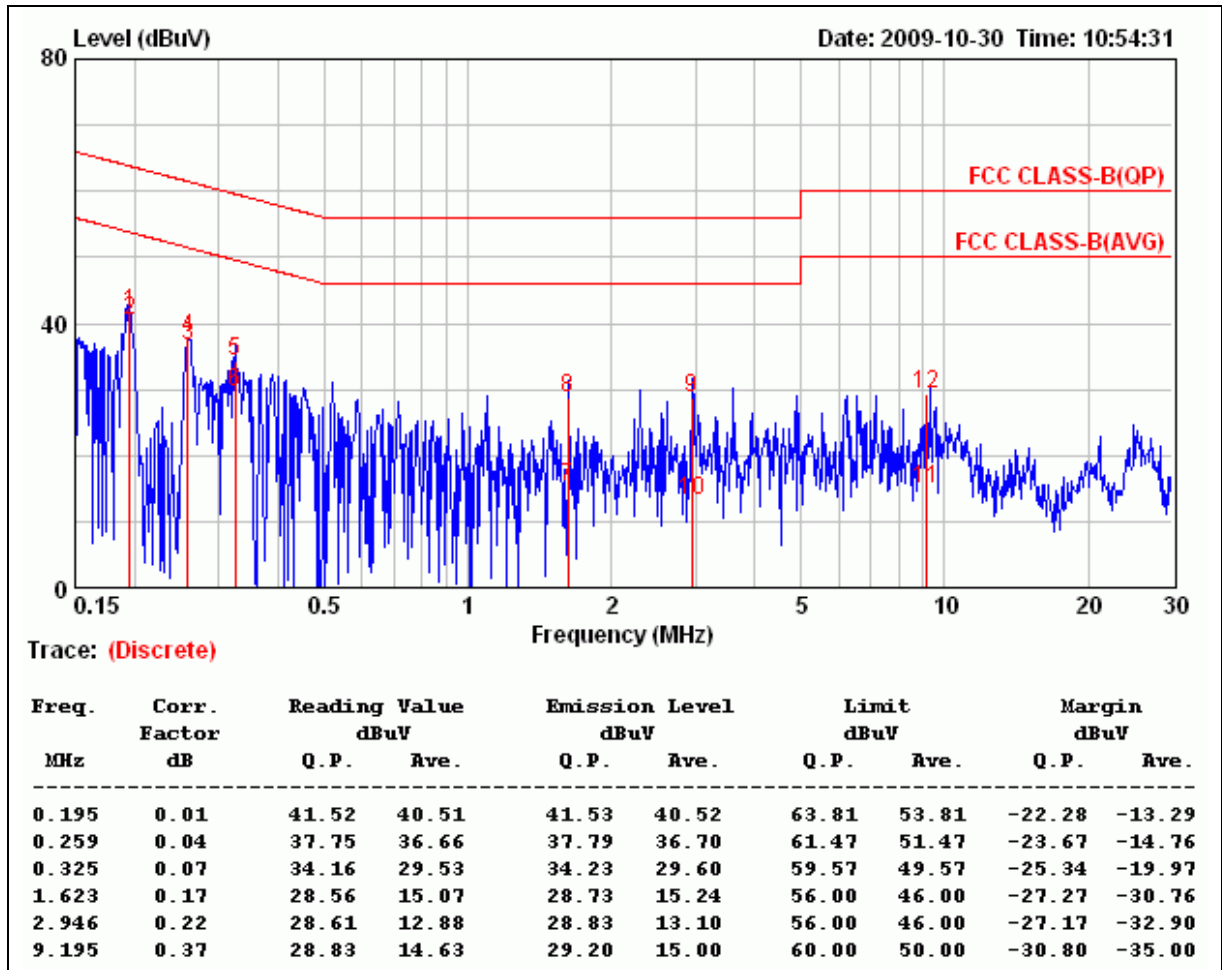

**Remark:**

1. Correction Factor = Insertion loss + cable loss
2. Margin value = Emission level – Limit value



<b>Product Name</b>	BLUETOOTH MODULE	<b>Test Date</b>	2009/11/02
<b>Model Name</b>	GUBTCR42M	<b>Test By</b>	Rick Lin
<b>Test Mode</b>	Normal operating / EMC-2 Power Adapter (1)	<b>TEMP &amp; Humidity</b>	25.1°C, 55%

LINE

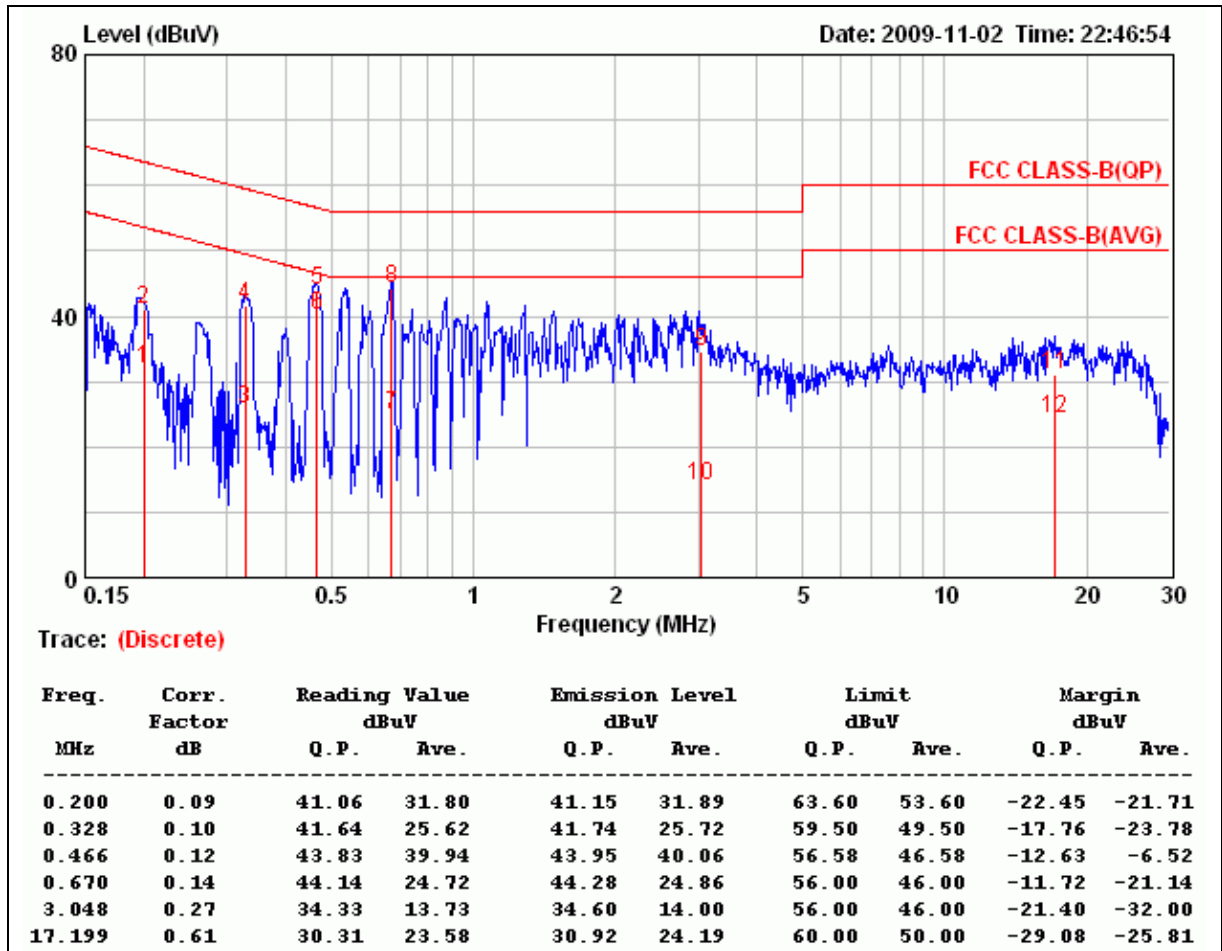

Remark:

1. Correction Factor = Insertion loss + cable loss
2. Margin value = Emission level – Limit value



<b>Product Name</b>	BLUETOOTH MODULE	<b>Test Date</b>	2009/11/02
<b>Model Name</b>	GUBTCR42M	<b>Test By</b>	Rick Lin
<b>Test Mode</b>	Normal operating / EMC-2 Power Adapter (1)	<b>TEMP &amp; Humidity</b>	25.1°C, 55%

NEUTRAL

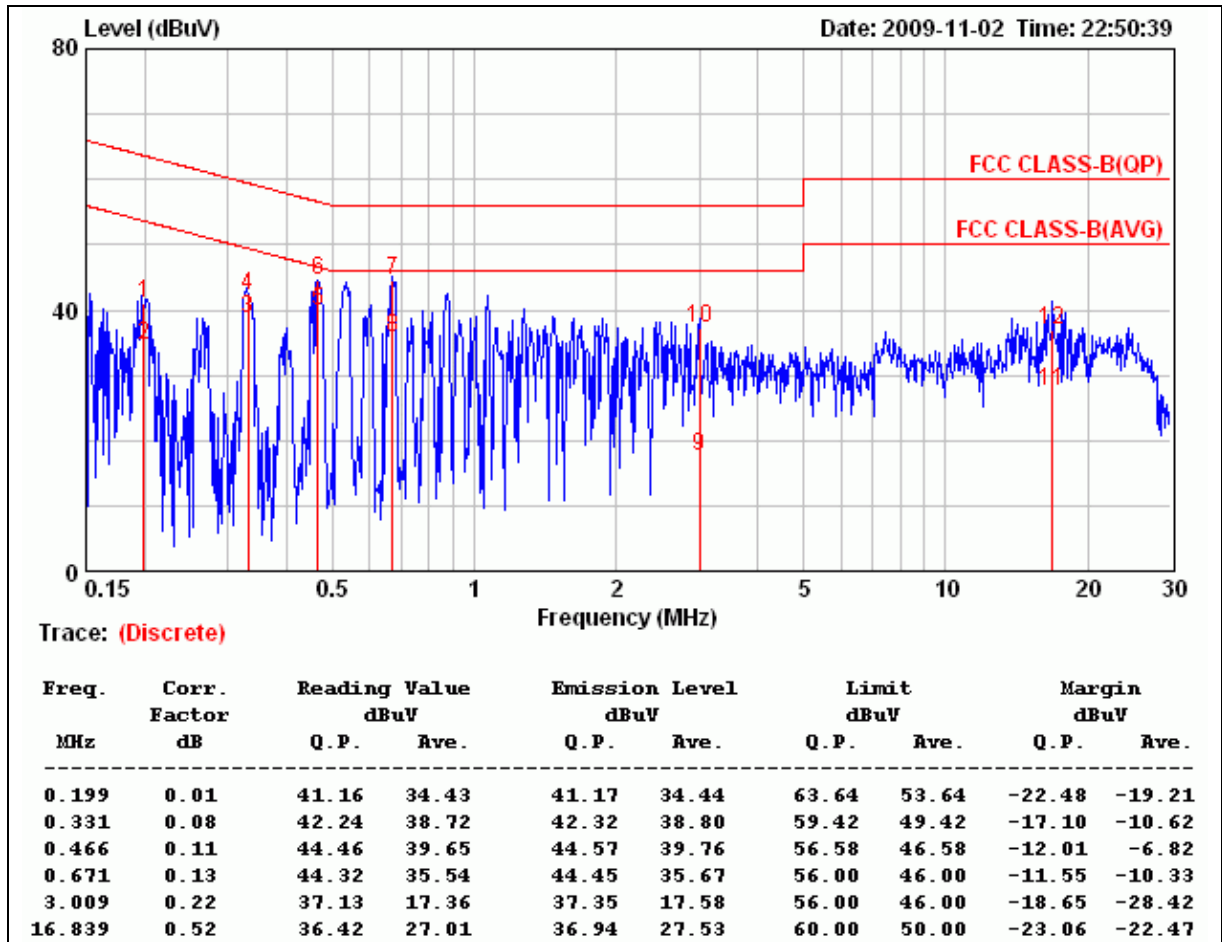

**Remark:**

1. Correction Factor = Insertion loss + cable loss
2. Margin value = Emission level – Limit value



<b>Product Name</b>	BLUETOOTH MODULE	<b>Test Date</b>	2009/10/30
<b>Model Name</b>	GUBTCR42M	<b>Test By</b>	Joe Peng
<b>Test Mode</b>	Normal operating / EMC-2 Power Adapter (2)	<b>TEMP &amp; Humidity</b>	24.4°C, 71%

LINE

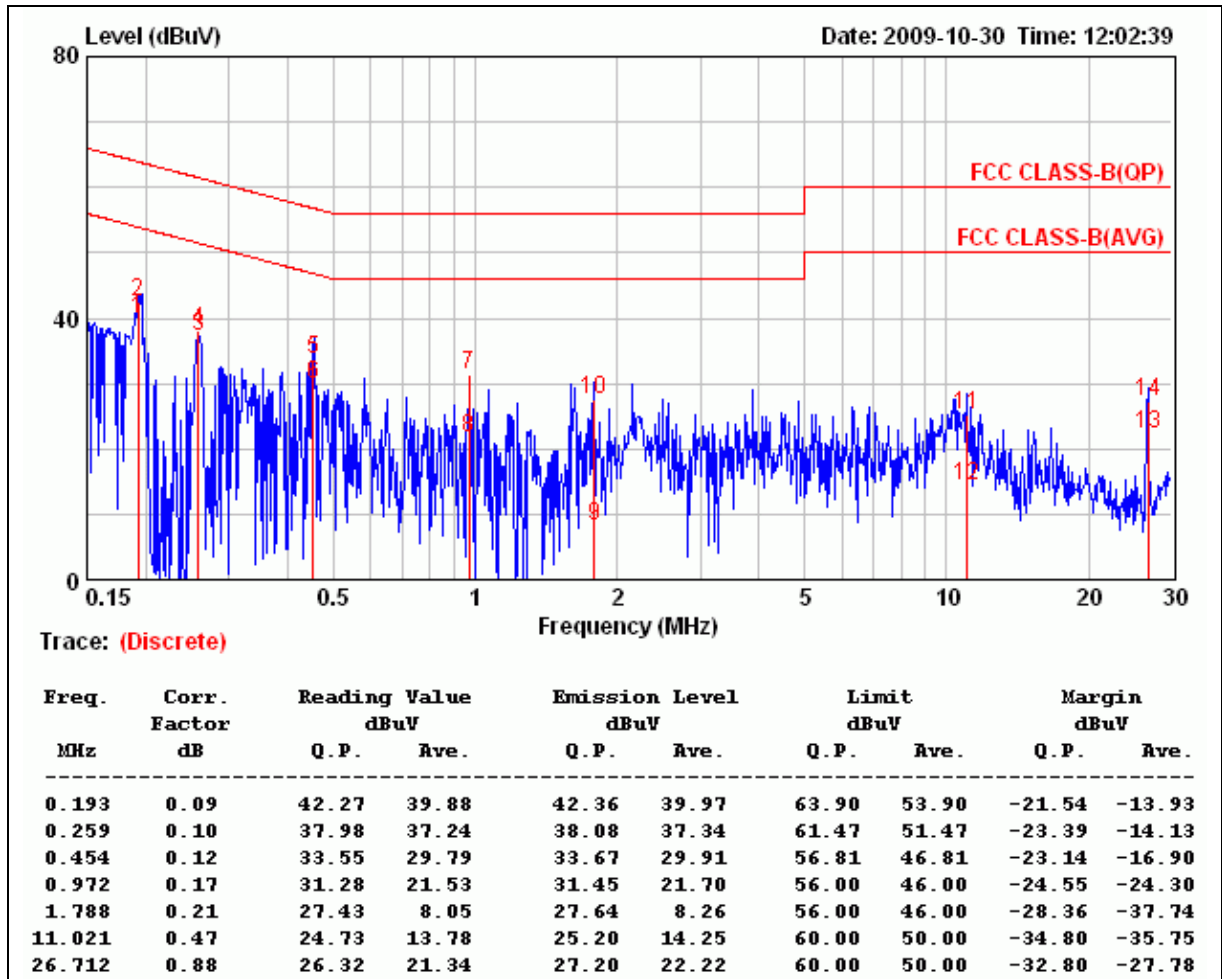

Remark:

1. Correction Factor = Insertion loss + cable loss
2. Margin value = Emission level – Limit value



<b>Product Name</b>	BLUETOOTH MODULE	<b>Test Date</b>	2009/10/30
<b>Model Name</b>	GUBTCR42M	<b>Test By</b>	Joe Peng
<b>Test Mode</b>	Normal operating / EMC-2 Power Adapter (2)	<b>TEMP &amp; Humidity</b>	24.4°C, 71%

NEUTRAL

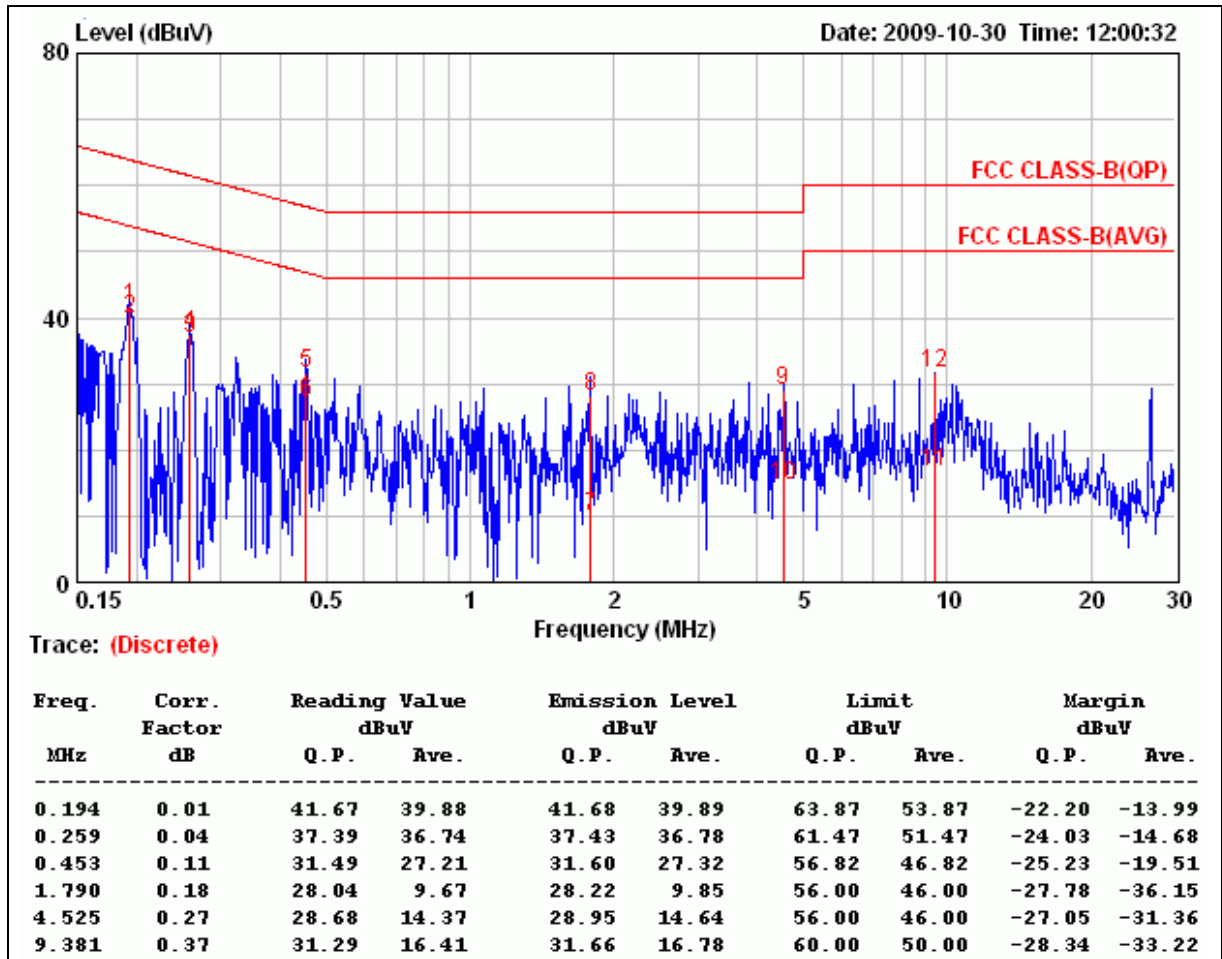

Remark:

1. Correction Factor = Insertion loss + cable loss
2. Margin value = Emission level – Limit value



<b>Product Name</b>	BLUETOOTH MODULE	<b>Test Date</b>	2009/10/29
<b>Model Name</b>	GUBTCR42M	<b>Test By</b>	Rick Lin
<b>Test Mode</b>	Normal operating / EMC-3 Power Adapter (1)	<b>TEMP &amp; Humidity</b>	24.4°C, 71%

LINE

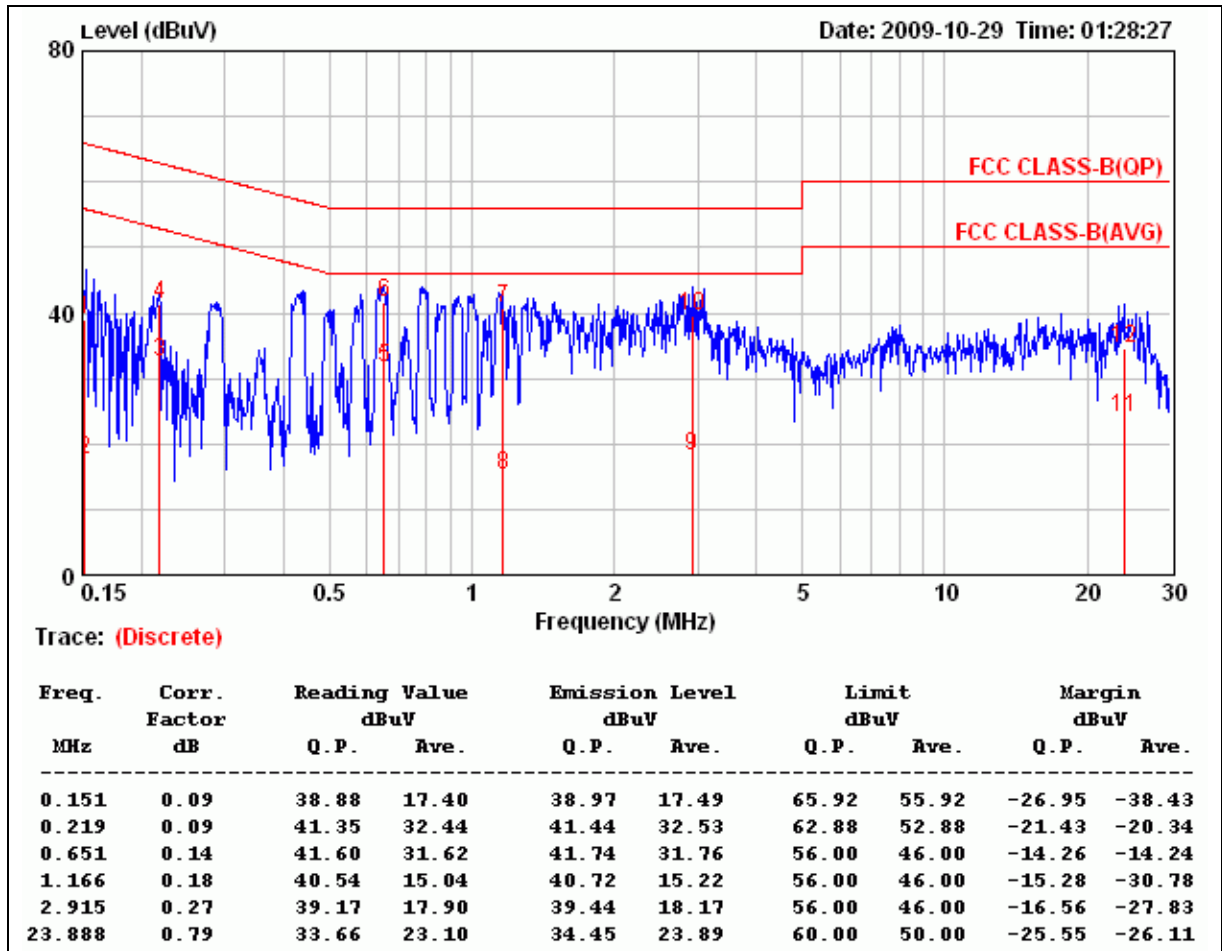

Remark:

1. Correction Factor = Insertion loss + cable loss
2. Margin value = Emission level – Limit value





<b>Product Name</b>	BLUETOOTH MODULE	<b>Test Date</b>	2009/10/29
<b>Model Name</b>	GUBTCR42M	<b>Test By</b>	Rick Lin
<b>Test Mode</b>	Normal operating / EMC-3 Power Adapter (1)	<b>TEMP &amp; Humidity</b>	24.4°C, 71%

NEUTRAL

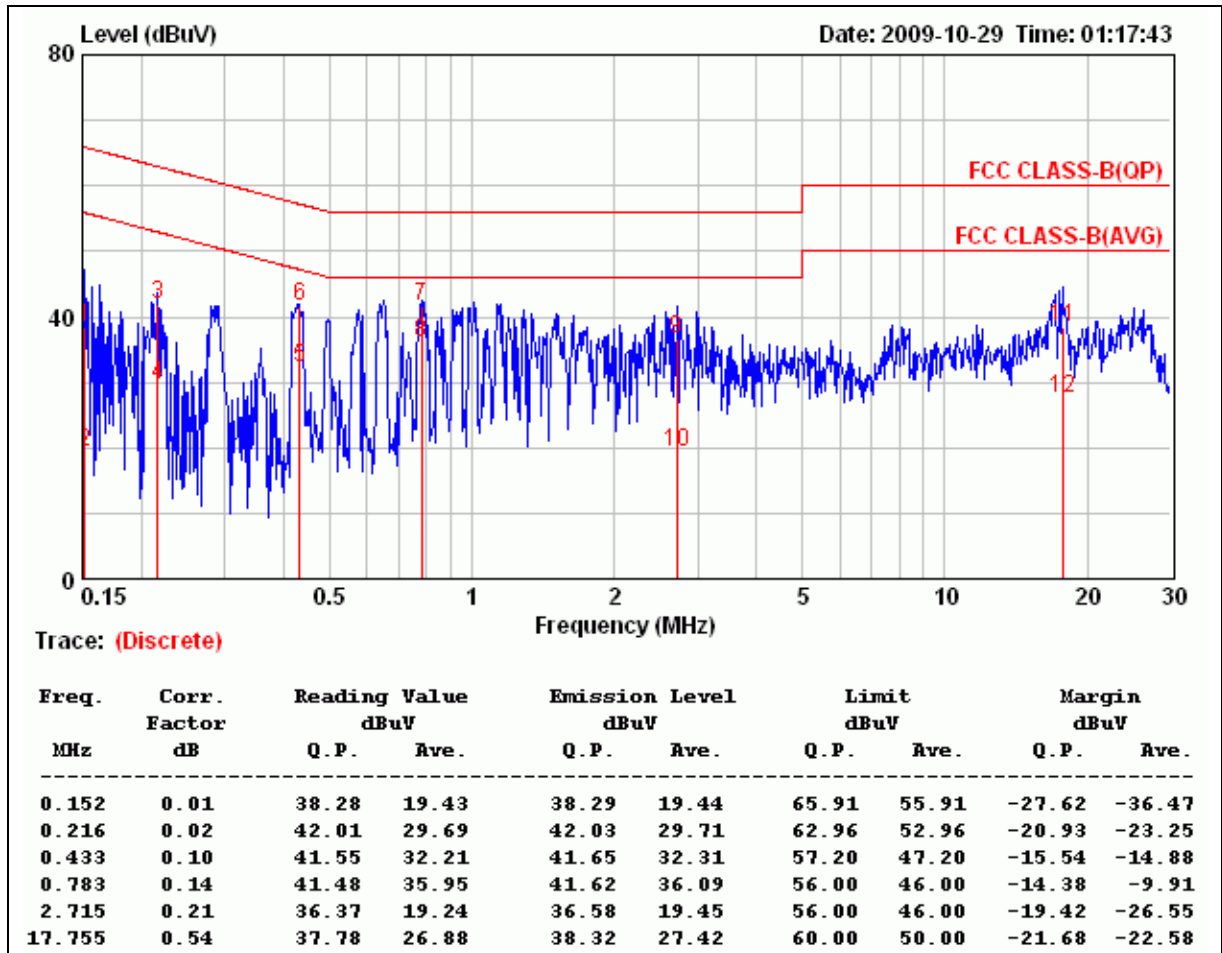

**Remark:**

1. Correction Factor = Insertion loss + cable loss
2. Margin value = Emission level – Limit value



<b>Product Name</b>	BLUETOOTH MODULE	<b>Test Date</b>	2009/10/30
<b>Model Name</b>	GUBTCR42M	<b>Test By</b>	Joe Peng
<b>Test Mode</b>	Normal operating / EMC-3 Power Adapter (2)	<b>TEMP &amp; Humidity</b>	24.4°C, 71%

LINE

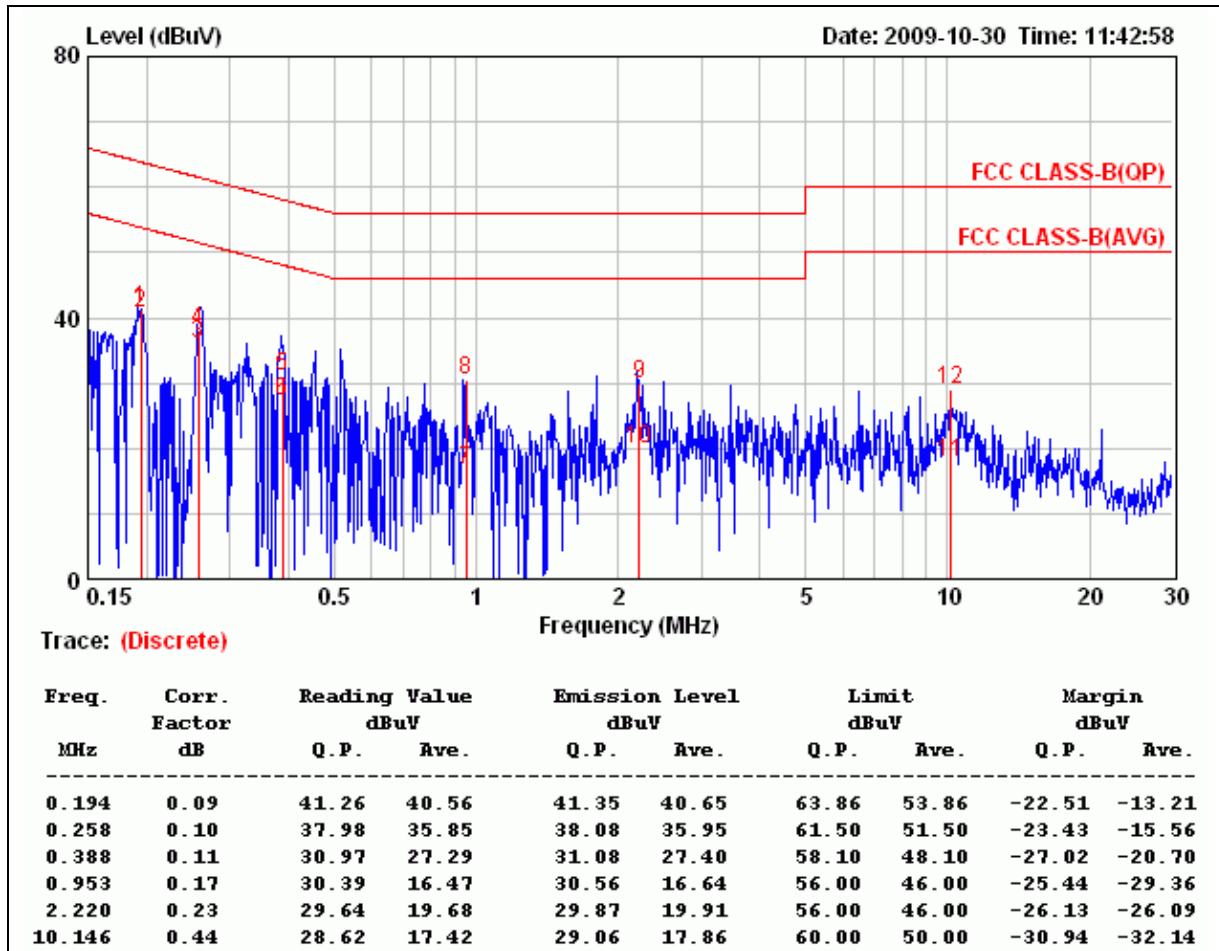

Remark:

1. Correction Factor = Insertion loss + cable loss
2. Margin value = Emission level – Limit value



<b>Product Name</b>	BLUETOOTH MODULE	<b>Test Date</b>	2009/10/30
<b>Model Name</b>	GUBTCR42M	<b>Test By</b>	Joe Peng
<b>Test Mode</b>	Normal operating / EMC-3 Power Adapter (2)	<b>TEMP &amp; Humidity</b>	24.4°C, 71%

NEUTRAL

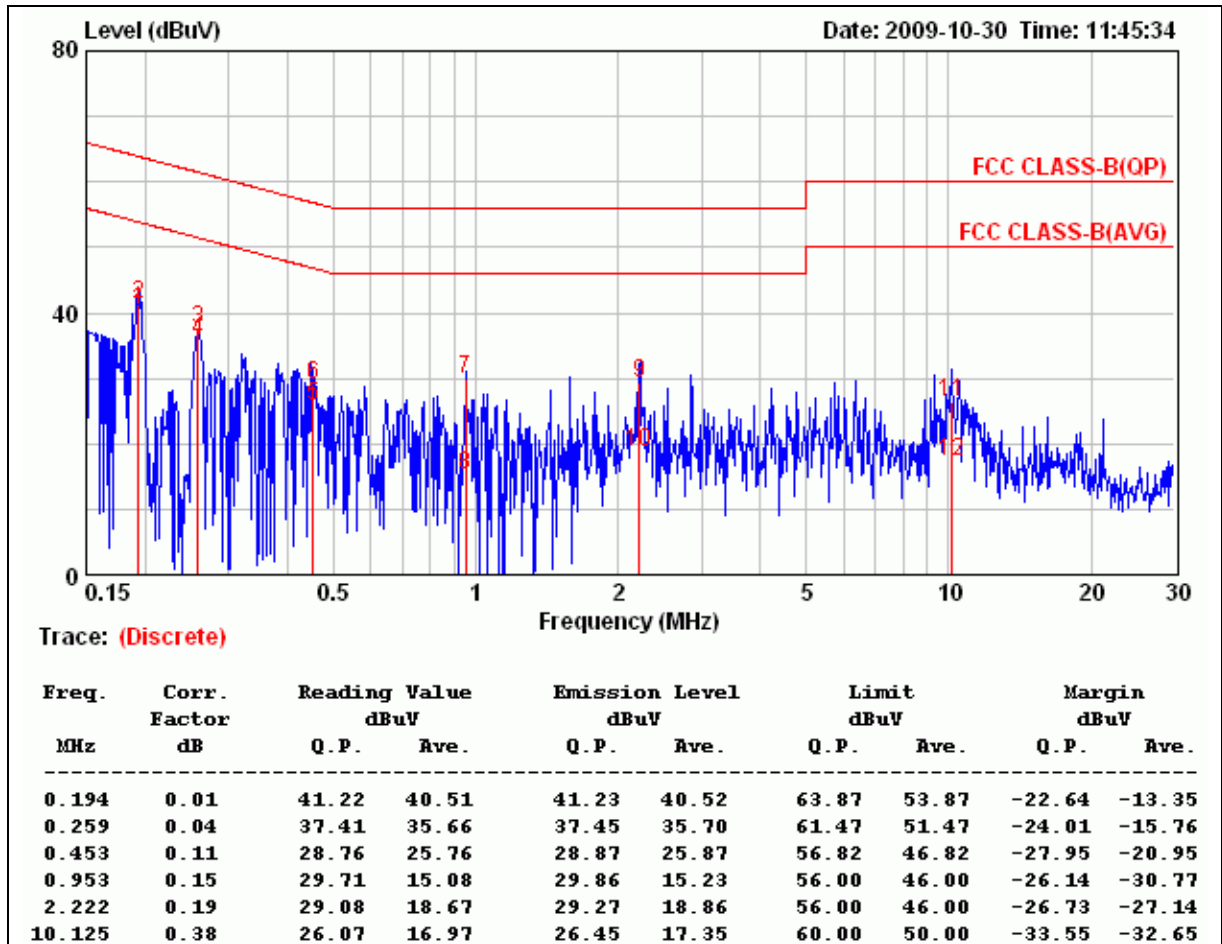

**Remark:**

1. Correction Factor = Insertion loss + cable loss
2. Margin value = Emission level – Limit value



## APPENDIX SETUP PHOTOS

### RADIATED EMISSION MEASUREMENT SETUP

#### EMC-1

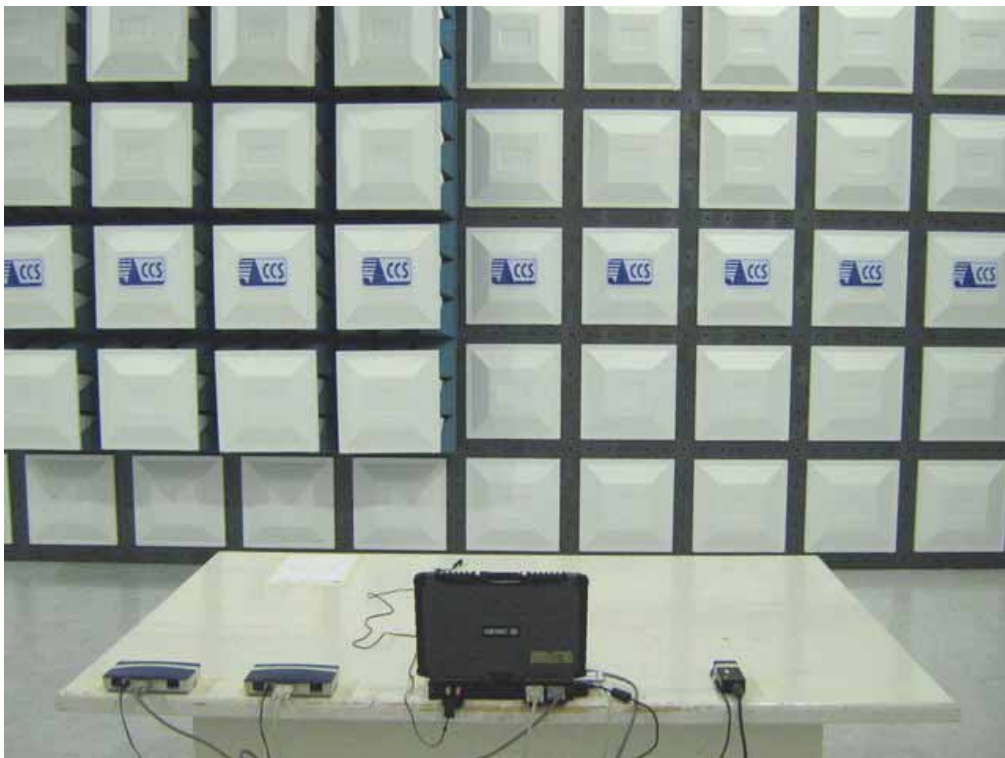

**EMC-2**



**EMC-3**





**POWERLINE CONDUCTED EMISSIONS MEASUREMENT SETUP**

**EMC-1**



**EMC-2**





**EMC-3**

