



FCC Test Report

According to

47 CFR Part 22H, 24E

Equipment : Notebook Personal Computer
Trade Name : GETAC
Model No. : V100
FCC ID : MAU029
Tx Frequency Range : WCDMA Band V : 826.4 ~ 846.6 MHz
WCDMA Band II : 1852.4 ~1907.6 MHz
Max. ERP/EIRP Power : WCDMA Band V : 0.08 W
WCDMA Band V(HSDPA) : 0.09 W
WCDMA Band II : 0.26 W
WCDMA Band II(HSDPA) : 0.27 W
Emission Designator : WCDMA : 4M22F9W
Applicant : MITAC Technology Corporation
4F, No.1, R&D Road 2, Hsinchu Science-Based
industrial Park, Hsinchu 300, Taiwan, R.O.C.

- The test result refers exclusively to the test presented test model / sample.
- Without written approval of SPORTON International Inc., the test report shall not be reproduced except in full.
- **Certificate or Test Report must not be used by the applicant to claim the product in this test report endorsement by NVLAP or any agency of U.S. government.**
- The data shown in this test report were carried out on Mar. 25, 2008 at **Sporton International Inc. LAB.**
- Report No.: FG812310-01, Report Version: Rev. 02.

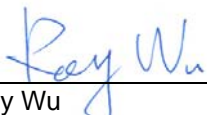

Roy Wu
Manager

SPORTON International Inc.

No. 52, Hwa Ya 1st Rd., Hwa Ya Technology Park, Kwei-Shan Hsiang, Tao Yuan Hsien, Taiwan, R.O.C.



Table of Contents

History of This Test Report ii

1. General Information 1

1.1 Applicant..... 1

1.2 Manufacturer 1

1.3 Basic Description of Equipment under Test..... 1

1.4 Feature of Equipment under Test..... 2

1.5 Report Date 4

2. Test Configuration of Equipment under Test 5

2.1 Test Manner 5

2.2 Test Mode 5

2.3 Connection Diagram of Test System 5

2.4 Ancillary Equipment List 5

3. General Information of Test Site..... 6

3.1 Test Voltage 6

3.2 Test Compliance..... 6

3.3 Frequency Range 6

3.4 Test Distance..... 6

4. Test Data and Test Result 7

4.1 List of Measurements and Examinations 7

4.2 RF Output Power 8

4.3 ERP / EIRP Measurement 11

4.4 Occupied Bandwidth and Band Edge Measurement 17

4.5 Conducted Emission..... 50

4.6 Field Strength of Spurious Radiation 69

4.7 Frequency Stability (Temperature Variation) 86

4.8 Frequency Stability (Voltage Variation) 89

5. List of Measurement Equipments 91

6. Uncertainty Evaluation 92

Appendix A - External Photographs of EUT

Appendix B - Internal Photographs of EUT

Appendix C - Setup Photographs

1. General Information

1.1 Applicant

MITAC Technology Corporation

4F, No.1, R&D Road 2, Hsinchu Science-Based industrial Park, Hsinchu 300, Taiwan, R.O.C.

1.2 Manufacturer

1 MITAC Technology Corporation

No. 1, R&D Road 2., Hsinchu Science-Based industrial Park Hsinchu 300, Taiwan, R.O.C.

2 Getac Technology (Kunshan) Co., Ltd

No. 269, 2nd Road, Export Processing Zone, Changjiang South Road, Kunshan, Jiangsu, P.R.C Zip code:215300

1.3 Basic Description of Equipment under Test

Equipment		Notebook Personal Computer
Trade Name		GETAC
Model Name		V100
FCC ID		MAU029
AC Adapter	Brand Name	EPS
	Model Name	F1090-A
	Power Rating	I/P: 100-240Vac, 50-60Hz, 1.2A; O/P: 19Vdc, 4.75A
	AC Power Cord Type	1.8 meter shielded cable without ferrite core
Battery	Brand Name	MITAC
	Model Name	BP-LC2600/33-0151
	Power Rating	11.1Vdc, 7800mAh
	Type	Li-ion
LCD Panel 1	Brand Name	Toshiba
	Model Name	LTD104KA1S
LCD Panel 2	Brand Name	Toshiba
	Model Name	LTD121EXEV

Remark: Above EUT's information was declared by manufacturer. Please refer to the specifications of manufacturer or User's Manual for more detailed features description.



1.4 Feature of Equipment under Test

Product Feature & Specification	
DUT Type :	Notebook Personal Computer
Trade Name :	GETAC
Model Name :	V100
FCC ID :	MAU029
Tx Frequency :	WCDMA Band V : 824 MHz ~ 849 MHz WCDMA Band II : 1850 MHz ~ 1910 MHz
Rx Frequency :	WCDMA Band V : 869 MHz ~ 894 MHz WCDMA Band II : 1930 MHz ~ 1990 MHz
Maximum Output Power to Antenna :	WCDMA Band V : 23.01 dBm(12.2kbps) / 22.68 dBm(64kbps) / 22.94 dBm(144kbps) / 22.84 dBm(384kbps) / 22.97 dBm (12.2kbps+HSDPA) WCDMA Band II : 23.12 dBm(12.2kbps) / 22.80 dBm(64kbps) / 22.70 dBm(144kbps) / 22.90 dBm(384kbps) / 22.78 dBm (12.2kbps+HSDPA)
Maximum ERP/EIRP :	WCDMA Band V : 0.08 W (18.93 dBm) WCDMA Band V(HSDPA) : 0.09 W (19.36 dBm) WCDMA Band II : 0.26 W (24.22 dBm) WCDMA Band II(HSDPA) : 0.27 W (24.31 dBm)
HW Version	2.1.4.0
SW Version	R2.0.1.1 Build1444
Type of Modulation :	WCDMA / HSDPA : QPSK
Type of Emission :	WCDMA : 4M22F9W
DUT Stage :	Production Unit



Notebook System Specification			
Item	Manufacturer	Model Name	Description
a.	CPU		Genuine intel U2500 1.2GHz
b.	Adapter Type	EPS	F10903-A INPUT:100-240V~1.2A 50/60Hz DC OUTPUT:19V---4.75A
c.	Hard Disk Driver	Toshiba	MK8032GAS 80GB
		Toshiba	MK1234GAS 120GB
d.	Modem Card	Conexant	RD-02-D330 N/A
e.	Wireless LAN Card	Intel	WM3945ABG N/A
f.	HSDPA Card	SIERRA WIRELESS	MC8775V N/A
g.	GPS Module	Globalsat	ET-301 N/A
h.	Bluetooth Module	Billionton	GUBTCR42M N/A
i.	USB Connector		two 4 pin
j.	RJ11 Connector		one 2 pin
k.	Serial Port		Two 9 pin
l.	RJ45 Connector		one 8 pin
m.	Line out Port		one
n.	Line-in Port		one
o.	SD Card Port		one
p.	PCMCIA Slot		two
q.	DC IN Port		one
r.	Battery	MITAC	BP-LC2600/33-0151 11.1Vdc, 7800mAh
s.	LCD	Toshiba	LTD104KA1S N/A
		Toshiba	LTD121EXEV N/A
t.	DDR	Infineon	HYS64T64020HDL-3.7-A 512M
		Hnnix	HYMP512S64CP8-Y5 AB 1G / Non-shielded, Data Cable
u.	WLAN Right antenna	JOINSOON ELECTRONICS MFG. CO., LTD.	N/A PIFA Antenna(P/N: IA-060076) White
v.	WLAN Left antenna	JOINSOON ELECTRONICS MFG. CO., LTD.	N/A PIFA Antenna(P/N: IA-060239) Black
w.	Bluetooth antenna	JOINSOON ELECTRONICS MFG. CO., LTD.	N/A PIFA Antenna(P/N: IA060093)
x.	WCDMA Right antenna	JOINSOON ELECTRONICS MFG. CO., LTD.	N/A PIFA Antenna(P/N: IA-060094) Blue
y.	WCDMA Left antenna	JOINSOON ELECTRONICS MFG. CO., LTD.	N/A PIFA Antenna(P/N: IA-060240) Red
z.	WLAN Right antenna		1.61dBi (11b,11g), 2.45dBi (11a)
aa.	WLAN Left antenna		-0.55dBi (11b,11g), 3.97dBi (11a)
bb.	Bluetooth antenna		-0.8dBi
cc.	WWAN Right antenna		0.53dBi (850MHz), 2.06dBi (1900MHz) ,-0.18dBi (2100MHz)
dd.	WWAN Left antenna		-1.88dBi (850MHz), 2.08dBi (1900MHz), 1.78dBi (2100MHz)



1.5 Report Date

EUT Received : Mar. 07, 2008

Report Date : May 08, 2008

2. Test Configuration of Equipment under Test

2.1 Test Manner

1. The spurious emission measurements were carried out in semi-anechoic chamber with 3-meter test range.
2. During all testings, EUT is in link mode with base station emulator at maximum power level.
3. Frequency range investigated: radiated emission 30 MHz to 9000 MHz for WCDMA Band V; 30MHz to 19000 MHz for WCDMA Band II.
4. All the test cases were tested on LCD panel 1, and ERP/EIRP was tested on LCD panel 2.

2.2 Test Mode

Application	WCDMA Band V	WCDMA Band II
Radiated Emission	Mode 1: WCDMA Link	Mode 3: WCDMA Link
	Mode 2: HSDPA Link	Mode 4: HSDPA Link
Conducted Measurement	Mode 1: WCDMA Link	Mode 3: WCDMA Link
	Mode 2: HSDPA Link	Mode 4: HSDPA Link

2.3 Connection Diagram of Test System

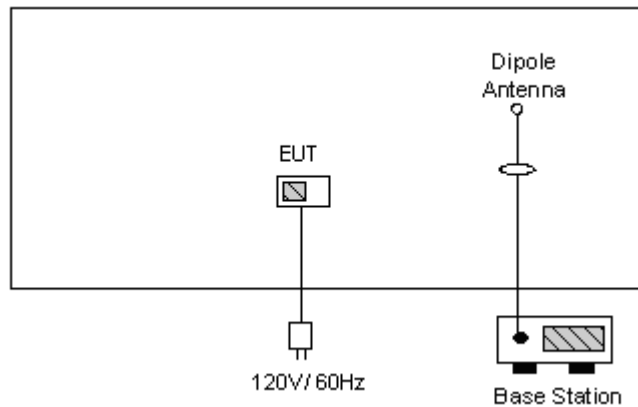

2.4 Ancillary Equipment List

Item	Equipment	Trade Name	Model No.	FCC ID	Data Cable / Power Code
1.	Base Station	R&S	CMU200	N/A	Unshielded, 1.8m



3. General Information of Test Site

Test Site Location : No. 52, Hwa Ya 1st Rd., Hwa Ya Technology Park,
Kwei-Shan Hsiang, Tao Yuan Hsien, Taiwan, R.O.C.
TEL : 886-3-327-3456
FAX : 886-3-328-4978
Test Site No : 03CH07-HY, TH02-HY
FCC Designation No : TW1022

The chamber meets the characteristics of ANSI C63.4-2003. This site is on file with the FCC.

3.1 Test Voltage

AC 120V / 60Hz

3.2 Test Compliance

47 CFR Part 22H, 24E, Part 2

Preliminary Guidance for Receiving Applications for Certification of 3G Device. May 9, 2006.

3.3 Frequency Range

- a. Radiation: from 30MHz to 9000MHz for WCDMA Band V.
- b. Radiation: from 30 MHz to 19000 MHz for WCDMA Band II.

3.4 Test Distance

The test distance of radiated emission from antenna to EUT is 3 m.



4. Test Data and Test Result

4.1 List of Measurements and Examinations

FCC Rule	Description of Test	Result	Section
§2.1046	RF Output Power	Passed	4.2
§ 22.913 §24.232	ERP / EIRP	Passed	4.3
§2.1049, § 22.917, § 24.238(b)	Occupied Bandwidth & Band Edge Measurement	Passed	4.4
§2.1051	Conducted Emission	Passed	4.5
§2.1053	Field Strength of Spurious Radiation	Passed	4.6
§2.1055, § 22.355, §24.235	Frequency Stability vs. Temperature	Passed	4.7
§2.1055, §22.355, §24.235	Frequency Stability vs. Voltage	Passed	4.8

4.2 RF Output Power

4.2.1 Measurement Instruments

As described in chapter 5 of this test report.

4.2.2 Test Procedure

- a. The transmitter output was connected to power meter and base station through power divider.
- b. Set EUT at maximum power through base station.
- c. Select lowest, middle, and highest channels for each band.

4.2.3 Test Setup Layout

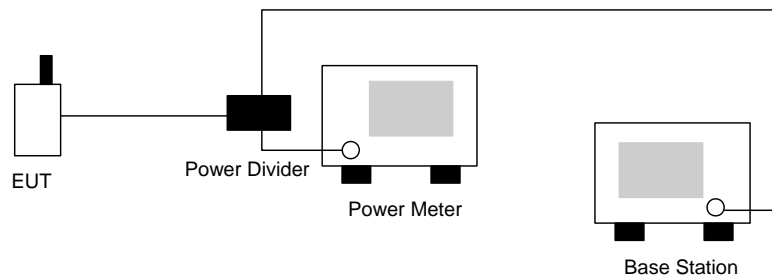



4.2.4 Test Result

Bands	Channel	Frequency (MHz)	Conducted Power (dBm)	Conducted Power (Watts)
WCDMA Band V (12.2k bps)	4132	826.4 (Low)	22.93	0.20
	4182	836.4 (Mid)	23.01	0.20
	4233	846.6 (High)	22.78	0.19
WCDMA Band V (64k bps)	4132	826.4 (Low)	22.63	0.19
	4182	836.4 (Mid)	22.68	0.20
	4233	846.6 (High)	22.34	0.19
WCDMA Band V (144k bps)	4132	826.4 (Low)	22.86	0.19
	4182	836.4 (Mid)	22.94	0.20
	4233	846.6 (High)	22.83	0.19
WCDMA Band V (384k bps)	4132	826.4 (Low)	22.84	0.19
	4182	836.4 (Mid)	22.79	0.19
	4233	846.6 (High)	22.52	0.18
WCDMA Band V (AMR)	4132	826.4 (Low)	22.51	0.18
	4182	836.4 (Mid)	22.60	0.18
	4233	846.6 (High)	22.38	0.17
WCDMA Band V (HSDPA)	4132	826.4 (Low)	22.89	0.19
	4182	836.4 (Mid)	22.97	0.20
	4233	846.6 (High)	22.78	0.19



Bands	Channel	Frequency (MHz)	Conducted Power (dBm)	Conducted Power (Watts)
WCDMA Band II (12.2k bps)	9262	1852.4 (Low)	22.66	0.18
	9400	1880.0 (Mid)	23.12	0.21
	9538	1907.6 (High)	22.32	0.17
WCDMA Band II (64k bps)	9262	1852.4 (Low)	22.69	0.19
	9400	1880.0 (Mid)	22.80	0.19
	9538	1907.6 (High)	22.17	0.16
WCDMA Band II (144k bps)	9262	1852.4 (Low)	22.68	0.19
	9400	1880.0 (Mid)	22.70	0.19
	9538	1907.6 (High)	22.16	0.16
WCDMA Band II (384k bps)	9262	1852.4 (Low)	22.75	0.19
	9400	1880.0 (Mid)	22.90	0.19
	9538	1907.6 (High)	22.33	0.17
WCDMA Band II (AMR)	9262	1852.4 (Low)	22.75	0.19
	9400	1880.0 (Mid)	22.88	0.19
	9538	1907.6 (High)	22.26	0.17
WCDMA Band II (HSDPA)	9262	1852.4 (Low)	22.71	0.19
	9400	1880.0 (Mid)	22.78	0.19
	9538	1907.6 (High)	22.16	0.16



4.3 ERP / EIRP Measurement

Equivalent isotropic radiated power measurements by substitution method according to ANSI/TIA/EIA-603-C.

4.3.1 Measurement Instruments

As described in chapter 5 of this test report.

4.3.2 Test Procedure

- a. The EUT was placed on a tutable with 1.0 meter height in an fully anechoic chamber.
- b. The EUT was set 1.2 meters from the receiving antenna which was mounted on the antenna tower.
- c. The table was rotated 360 degrees to determine the position of the highest radiated power.
- d. The height of the receiving antenna is also kept at 1.0M height.
- e. Taking the record of maximum ERP/EIRP.
- f. A dipole antenna was substituted in place of the EUT and was driven by a signal generator.
- g. The conducted power at the terminal of the dipole antenna is measured.
- h. Repeat step 3 to step 5 to get the maximum ERP/EIRP of the substitution antenna.
- i. $ERP/EIRP = P_s + E_t - E_s + G_s = P_s + R_t - R_s + G_s$

P_s (dBm) : Input power to substitution antenna.

G_s (dBi or dBd) : Substitution antenna Gain.

$E_t = R_t + AF$

$E_s = R_s + AF$

AF (dB/m) : Receive antenna factor

R_t : The highest received signal in Spectrum Analyzer for EUT.

R_s : The highest received signal in spectrum analyzer for substitution antenna.

4.3.3 Test Setup Layout of ERP/EIRP

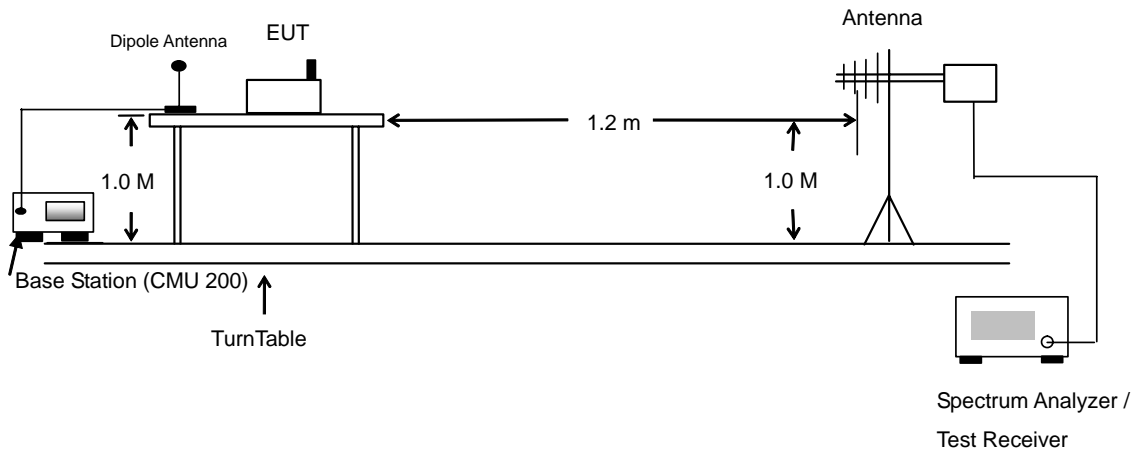



4.3.4 Test Result

<LCD Panel 1>

WCDMA Band V Radiated Power ERP						
Horizontal Polarization						
Frequency (MHz)	Rt (dBm)	Rs (dBm)	Ps (dBm)	Gs (dBd)	ERP (dBm)	ERP (W)
826.40	-28.99	-48.12	0.00	-1.08	18.05	0.06
836.40	-29.65	-48.28	0.00	-0.93	17.70	0.06
846.60	-30.33	-48.35	0.00	-0.76	17.26	0.05
Vertical Polarization						
Frequency (MHz)	Rt (dBm)	Rs (dBm)	Ps (dBm)	Gs (dBd)	ERP (dBm)	ERP (W)
826.40	-27.96	-47.97	0.00	-1.08	18.93	0.08
836.40	-28.18	-48.01	0.00	-0.93	18.90	0.08
846.60	-28.57	-48.05	0.00	-0.76	18.72	0.07

WCDMA Band V (HSDPA) Radiated Power ERP						
Horizontal Polarization						
Frequency (MHz)	Rt (dBm)	Rs (dBm)	Ps (dBm)	Gs (dBd)	ERP (dBm)	ERP (W)
826.40	-29.46	-48.12	0.00	-1.08	17.58	0.06
836.40	-29.44	-48.28	0.00	-0.93	17.91	0.06
846.60	-30.05	-48.35	0.00	-0.76	17.54	0.06
Vertical Polarization						
Frequency (MHz)	Rt (dBm)	Rs (dBm)	Ps (dBm)	Gs (dBd)	ERP (dBm)	ERP (W)
826.40	-28.20	-47.97	0.00	-1.08	18.69	0.07
836.40	-28.15	-48.01	0.00	-0.93	18.93	0.08
846.60	-27.93	-48.05	0.00	-0.76	19.36	0.09



WCDMA Band II Radiated Power EIRP						
Horizontal Polarization						
Frequency (MHz)	Rt (dBm)	Rs (dBm)	Ps (dBm)	Gs (dBi)	EIRP (dBm)	EIRP (W)
1852.40	-32.00	-51.88	0.00	1.96	21.84	0.15
1880.00	-33.17	-52.99	0.00	2.00	21.82	0.15
1907.60	-34.27	-54.28	0.00	1.98	21.99	0.16
Vertical Polarization						
Frequency (MHz)	Rt (dBm)	Rs (dBm)	Ps (dBm)	Gs (dBi)	EIRP (dBm)	EIRP (W)
1852.40	-30.31	-52.13	0.00	1.96	23.78	0.24
1880.00	-30.95	-53.17	0.00	2.00	24.22	0.26
1907.60	-32.36	-54.13	0.00	1.98	23.75	0.24

WCDMA Band II (HSDPA) Radiated Power EIRP						
Horizontal Polarization						
Frequency (MHz)	Rt (dBm)	Rs (dBm)	Ps (dBm)	Gs (dBi)	EIRP (dBm)	EIRP (W)
1852.40	-32.69	-51.88	0.00	1.96	21.15	0.13
1880.00	-33.34	-52.99	0.00	2.00	21.65	0.15
1907.60	-34.51	-54.28	0.00	1.98	21.75	0.15
Vertical Polarization						
Frequency (MHz)	Rt (dBm)	Rs (dBm)	Ps (dBm)	Gs (dBi)	EIRP (dBm)	EIRP (W)
1852.40	-29.78	-52.13	0.00	1.96	24.31	0.27
1880.00	-30.98	-53.17	0.00	2.00	24.19	0.26
1907.60	-32.22	-54.13	0.00	1.98	23.89	0.24



<LCD Panel 2>

WCDMA Band V Radiated Power ERP						
Horizontal Polarization						
Frequency (MHz)	Rt (dBm)	Rs (dBm)	Ps (dBm)	Gs (dBd)	ERP (dBm)	ERP (W)
826.40	-30.59	-48.12	0.00	-1.08	16.45	0.04
836.40	-30.52	-48.28	0.00	-0.93	16.83	0.05
846.60	-30.73	-48.35	0.00	-0.76	16.86	0.05
Vertical Polarization						
Frequency (MHz)	Rt (dBm)	Rs (dBm)	Ps (dBm)	Gs (dBd)	ERP (dBm)	ERP (W)
826.40	-30.29	-47.97	0.00	-1.08	16.60	0.05
836.40	-29.80	-48.01	0.00	-0.93	17.28	0.05
846.60	-29.80	-48.05	0.00	-0.76	17.49	0.06

WCDMA Band V (HSDPA) Radiated Power ERP						
Horizontal Polarization						
Frequency (MHz)	Rt (dBm)	Rs (dBm)	Ps (dBm)	Gs (dBd)	ERP (dBm)	ERP (W)
826.40	-29.29	-48.12	0.00	-1.08	17.75	0.06
836.40	-29.78	-48.28	0.00	-0.93	17.57	0.06
846.60	-30.16	-48.35	0.00	-0.76	17.43	0.06
Vertical Polarization						
Frequency (MHz)	Rt (dBm)	Rs (dBm)	Ps (dBm)	Gs (dBd)	ERP (dBm)	ERP (W)
826.40	-29.69	-47.97	0.00	-1.08	17.20	0.05
836.40	-29.71	-48.01	0.00	-0.93	17.37	0.05
846.60	-29.55	-48.05	0.00	-0.76	17.74	0.06



WCDMA Band II Radiated Power EIRP						
Horizontal Polarization						
Frequency (MHz)	Rt (dBm)	Rs (dBm)	Ps (dBm)	Gs (dBi)	EIRP (dBm)	EIRP (W)
1852.40	-34.94	-51.88	0.00	1.96	18.90	0.08
1880.00	-35.38	-52.99	0.00	2.00	19.61	0.09
1907.60	-36.83	-54.28	0.00	1.98	19.43	0.09
Vertical Polarization						
Frequency (MHz)	Rt (dBm)	Rs (dBm)	Ps (dBm)	Gs (dBi)	EIRP (dBm)	EIRP (W)
1852.40	-32.18	-52.13	0.00	1.96	21.91	0.16
1880.00	-32.98	-53.17	0.00	2.00	22.19	0.17
1907.60	-33.82	-54.13	0.00	1.98	22.29	0.17

WCDMA Band II (HSDPA) Radiated Power EIRP						
Horizontal Polarization						
Frequency (MHz)	Rt (dBm)	Rs (dBm)	Ps (dBm)	Gs (dBi)	EIRP (dBm)	EIRP (W)
1852.40	-34.32	-51.88	0.00	1.96	19.52	0.09
1880.00	-34.96	-52.99	0.00	2.00	20.03	0.10
1907.60	-36.32	-54.28	0.00	1.98	19.94	0.10
Vertical Polarization						
Frequency (MHz)	Rt (dBm)	Rs (dBm)	Ps (dBm)	Gs (dBi)	EIRP (dBm)	EIRP (W)
1852.40	-32.04	-52.13	0.00	1.96	22.05	0.16
1880.00	-33.01	-53.17	0.00	2.00	22.16	0.16
1907.60	-33.58	-54.13	0.00	1.98	22.53	0.18

4.4 Occupied Bandwidth and Band Edge Measurement

4.4.1 Measurement Instruments

As described in chapter 5 of this test report.

4.4.2 Test Procedure

- a. The EUT was connected to Spectrum Analyzer and Base Station via power divider.
- b. The 99% occupied bandwidth of middle channel for the highest and lowest RF powers were measured.
- c. The bandedge of low and high channels for the highest RF powers within the transmitting frequency band were measured. Setting RBW as roughly $BW/100$.

4.4.3 Test Setup Layout

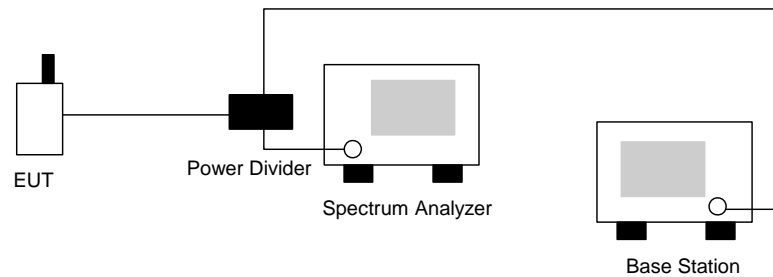



4.4.4 Test Result

- Mode 1
- Test Mode : WCDMA Band V CH4132 Lower Band Edge
- Power State : High

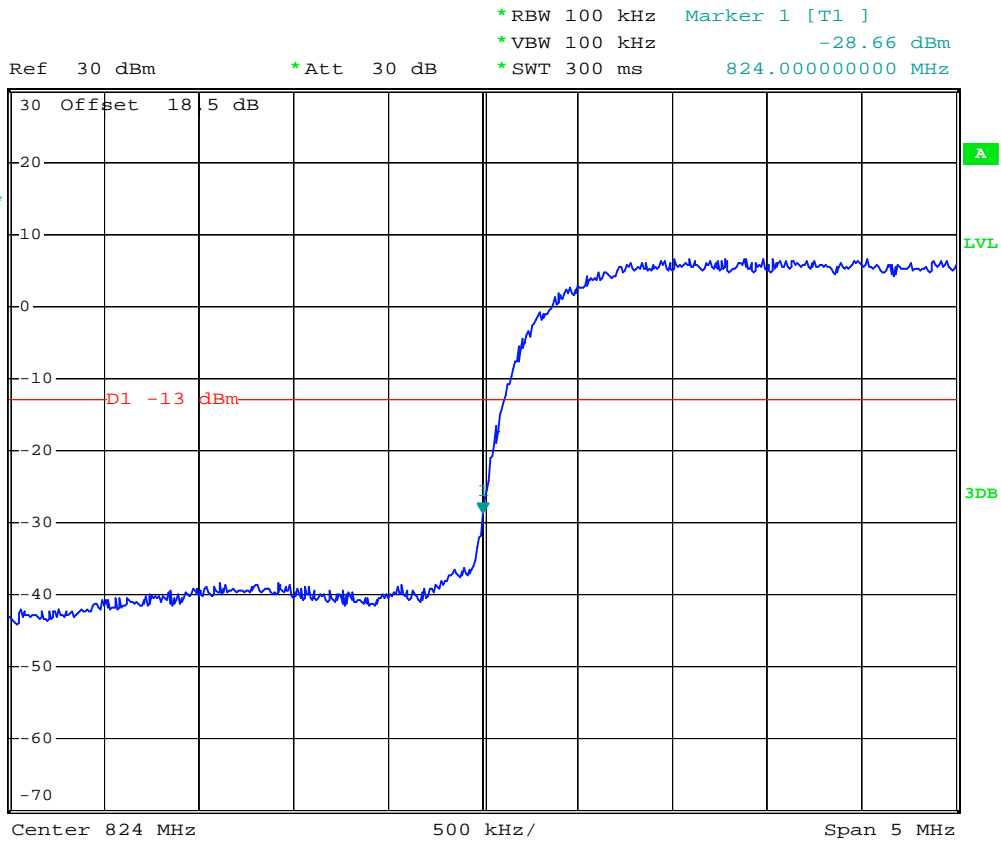

Date: 21.FEB.2008 10:51:41



- Test Mode : WCDMA Band V CH4132 99% Occupied Bandwidth
- Power State : High

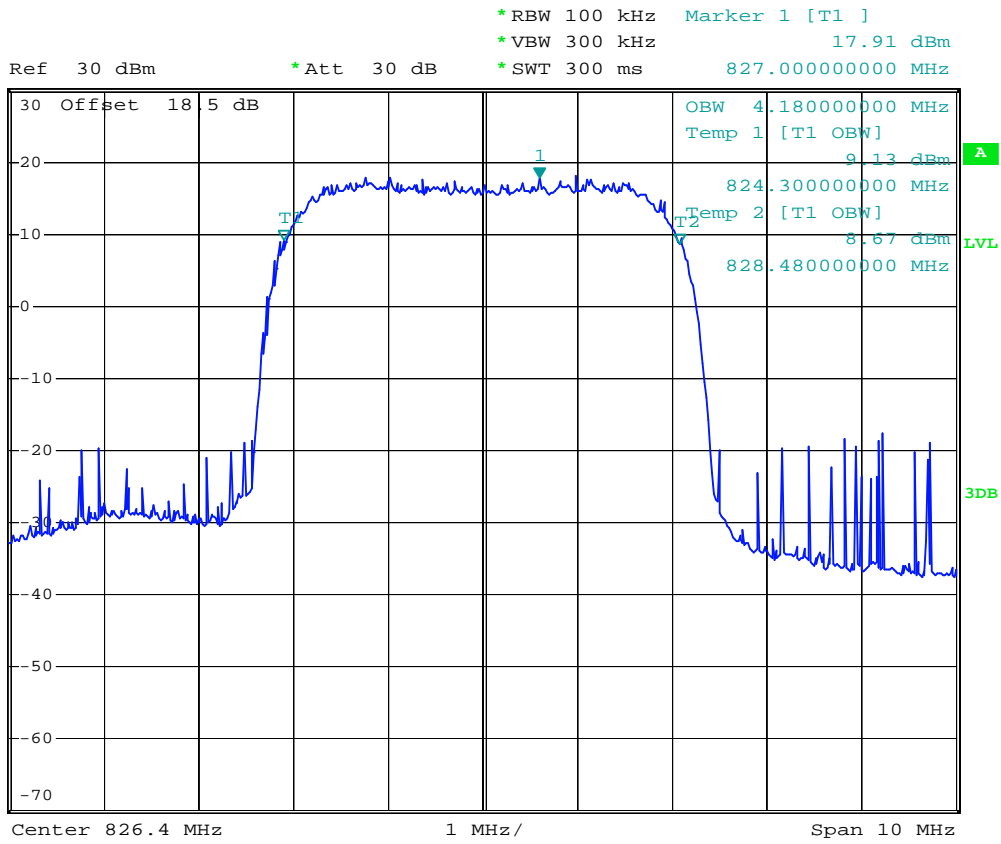

Date: 21.FEB.2008 10:32:50



- Test Mode : WCDMA Band V CH4182 99% Occupid Bandwidth
- Power State : High

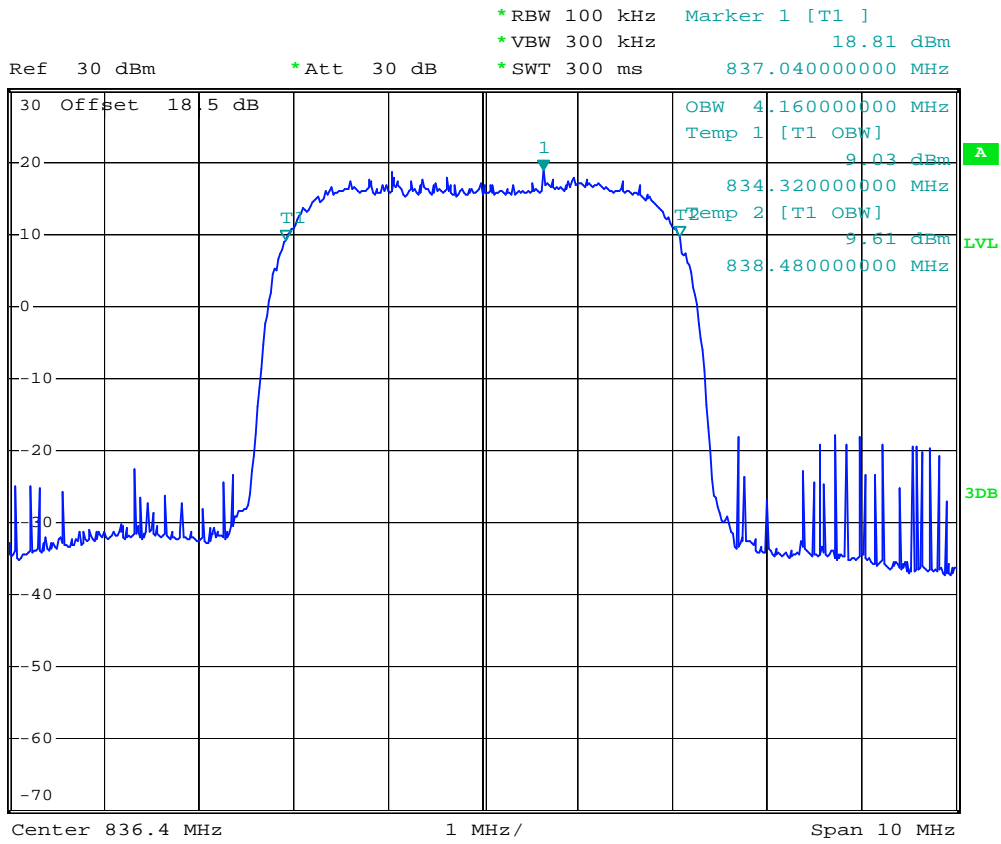

Date: 21.FEB.2008 10:33:26



- Test Mode : WCDMA Band V CH4233 99% Occupied Bandwidth
- Power State : High

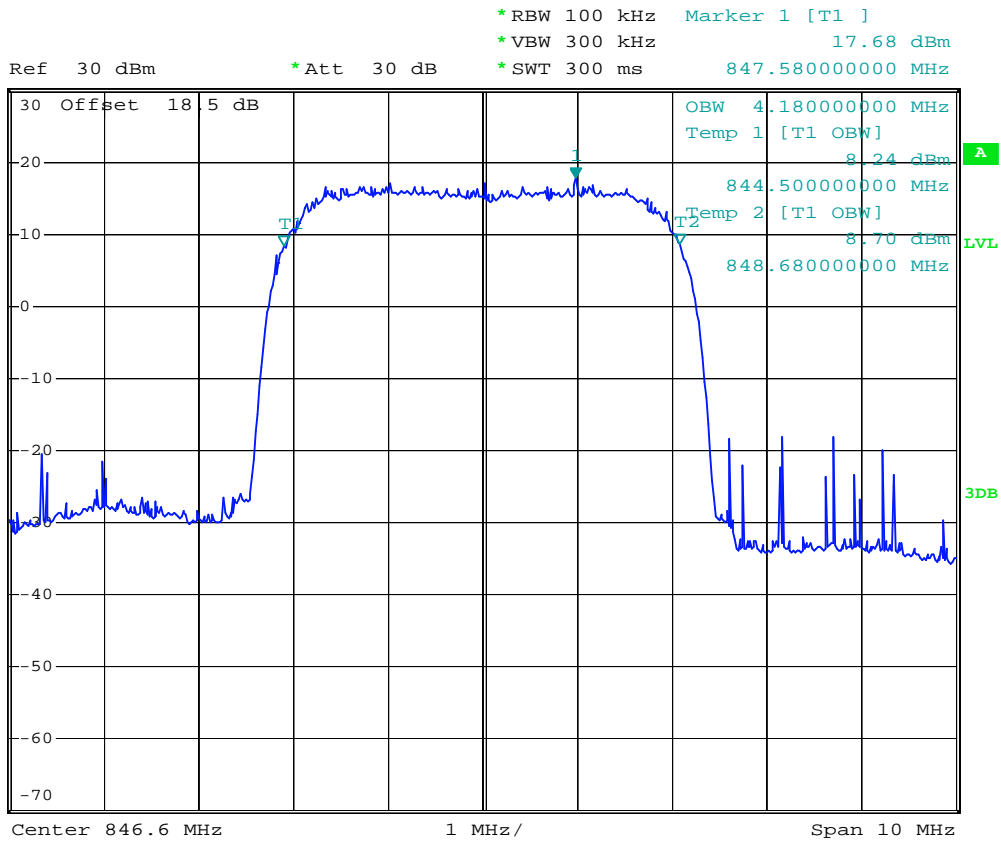

Date: 21.FEB.2008 10:34:01



- Test Mode : WCDMA Band V CH4132 26dB Bandwidth
- Power State : High



*RBW 100 kHz Delta 2 [T1]
 *VBW 300 kHz -0.45 dB
 *SWT 300 ms 4.640000000 MHz

Ref 30 dBm

*Att 30 dB

1 PK
VIEW

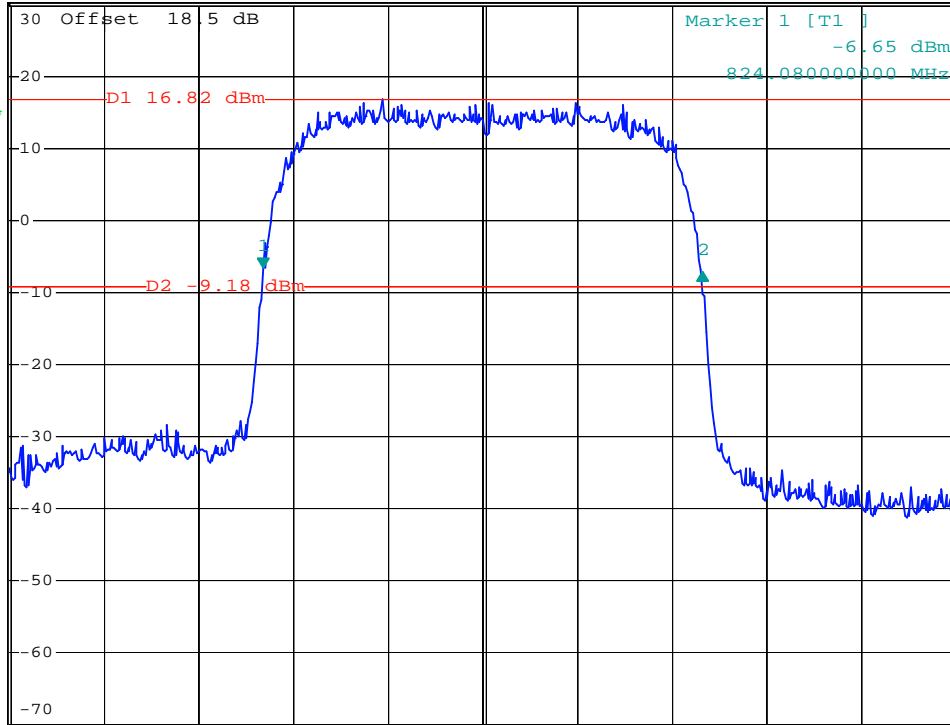

Center 826.4 MHz

1 MHz/

Span 10 MHz

Date: 21.FEB.2008 10:25:45



- Test Mode : WCDMA Band V CH4182 26dB Bandwidth
- Power State : High



*RBW 100 kHz Delta 2 [T1]
 *VBW 300 kHz 0.96 dB
 *SWT 300 ms 4.680000000 MHz

Ref 30 dBm

*Att 30 dB

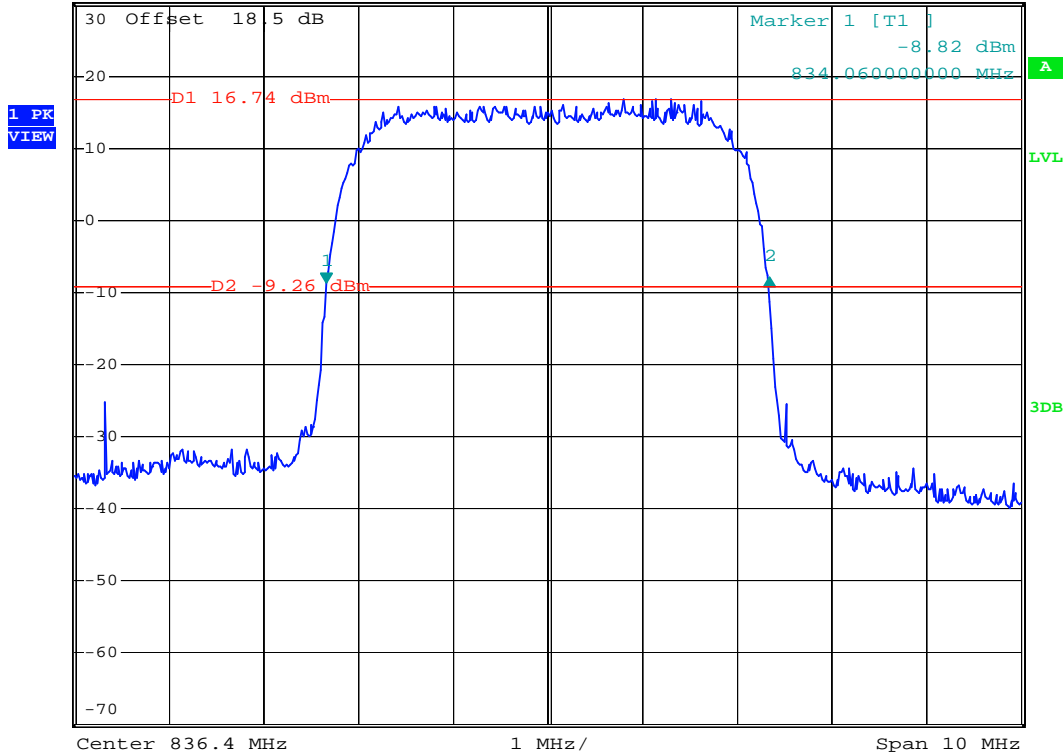

Date: 21.FEB.2008 10:27:33



- Test Mode : WCDMA Band V CH4233 26dB Bandwidth
- Power State : High

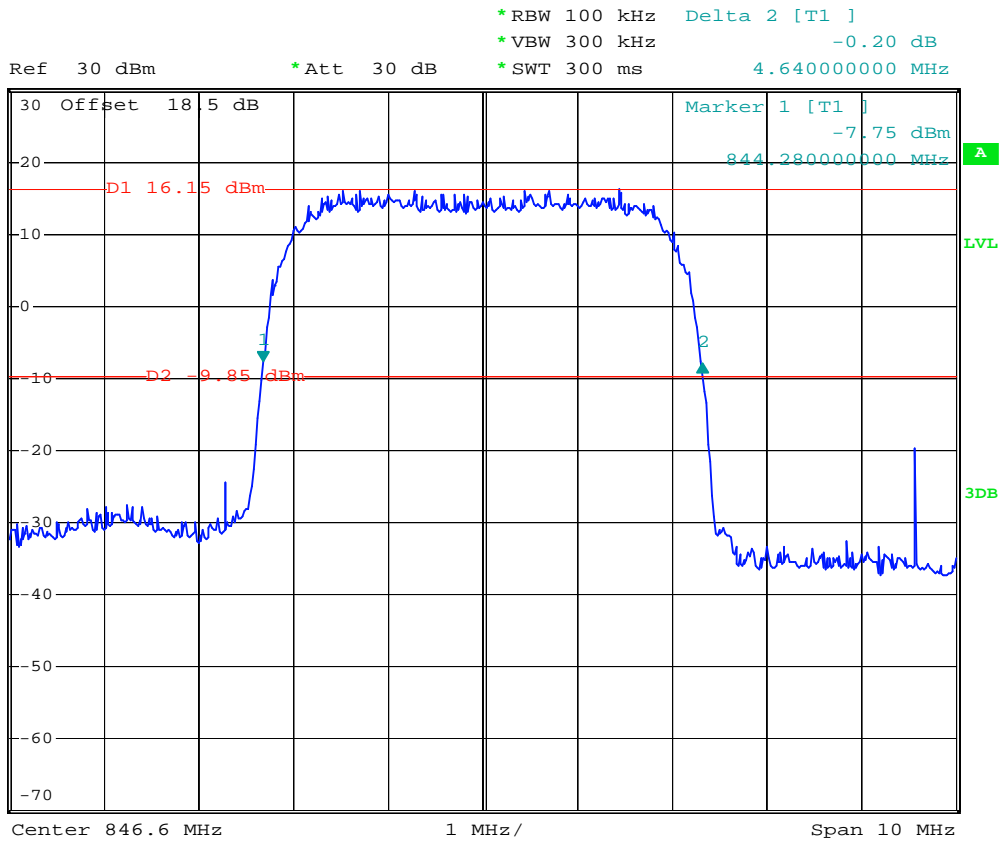

Date: 21.FEB.2008 10:29:00



- Test Mode : WCDMA Band V CH4233 Higher Band Edge
- Power State : High



Ref 30 dBm *Att 30 dB *RBW 100 kHz Marker 1 [T1]
*VBW 100 kHz -28.77 dBm
*SWT 300 ms 849.000000000 MHz

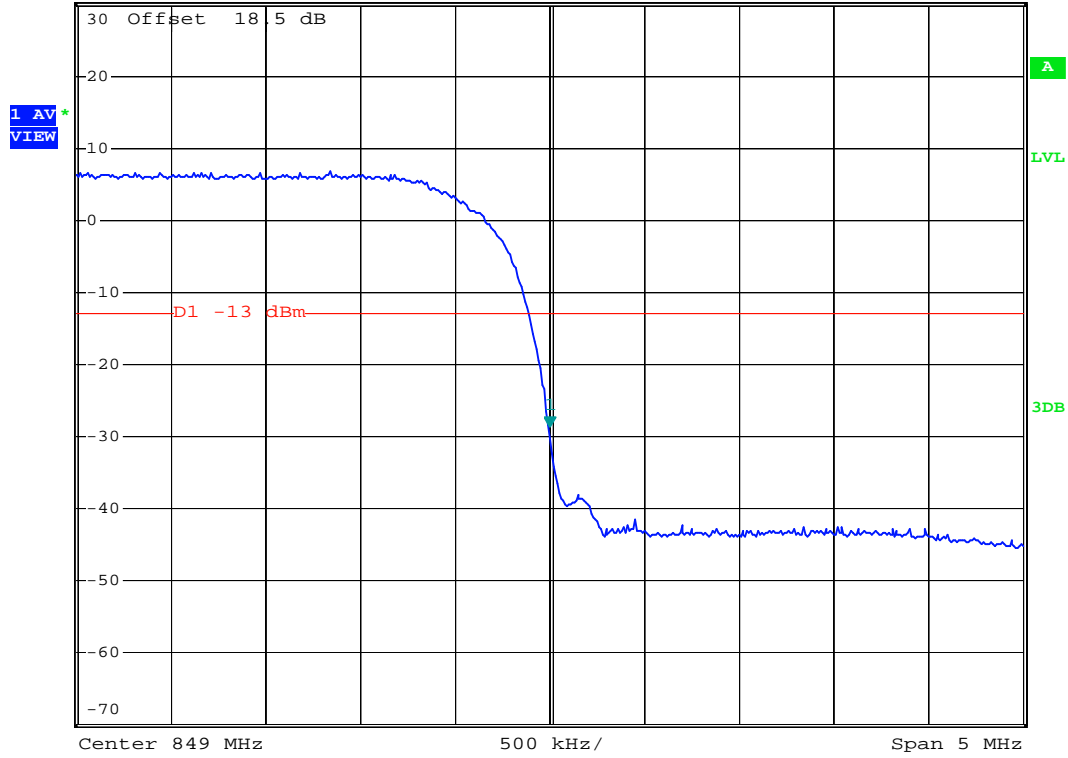

Date: 21.FEB.2008 10:51:01



- Mode 2
- Test Mode : WCDMA Band V (HSDPA) CH4132 Lower Band Edge
- Power State : High

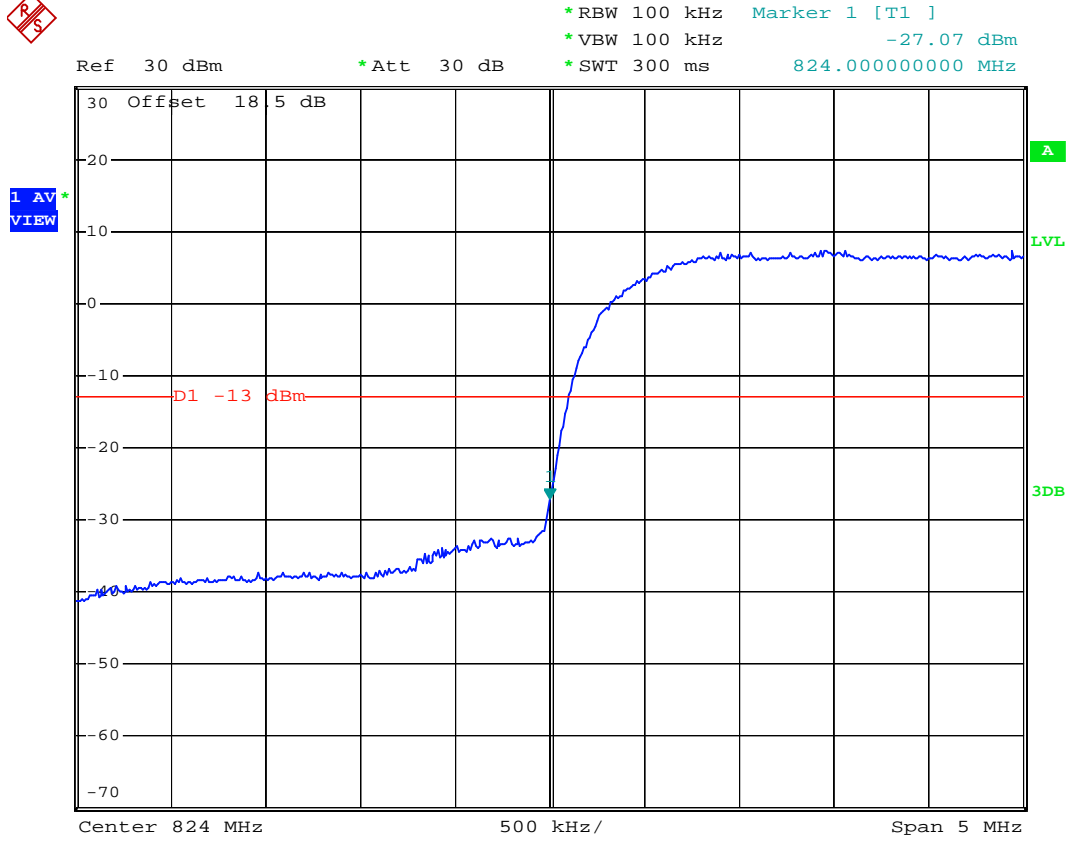

Date: 21.FEB.2008 19:12:49



- Test Mode : WCDMA Band V (HSDPA) CH4182 99% Occupied Bandwidth
- Power State : High

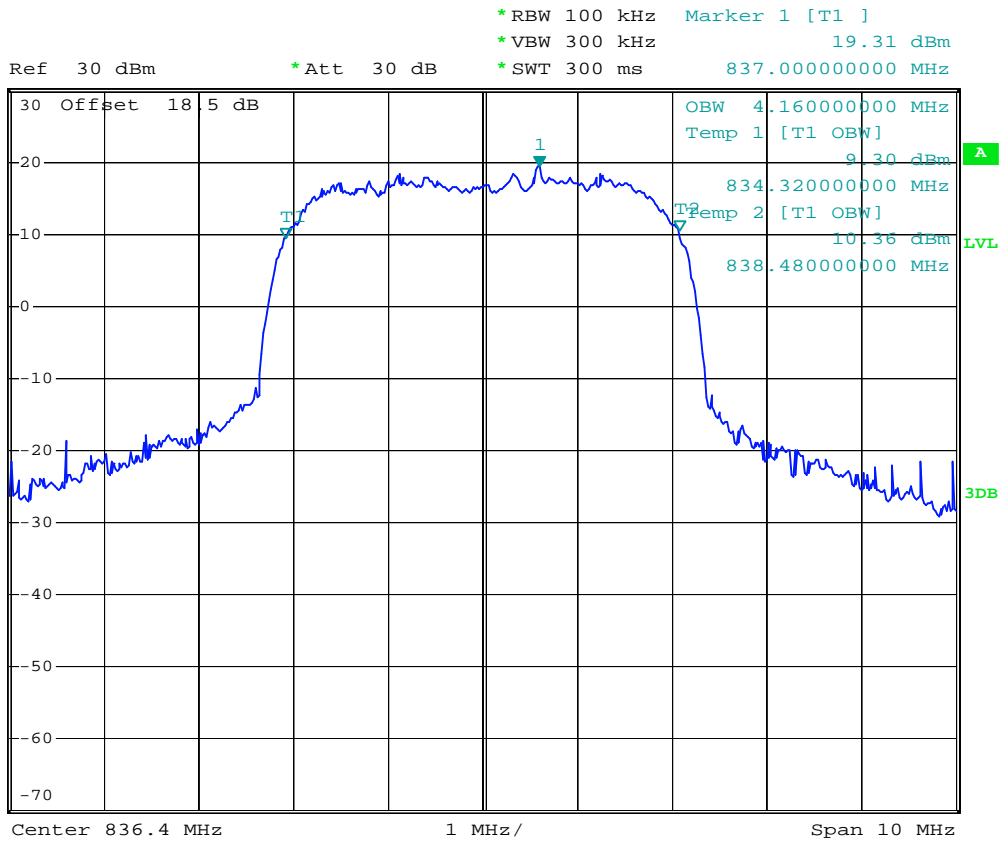

Date: 21.FEB.2008 19:09:17



- Test Mode : WCDMA Band V (HSDPA) CH4233 99% Occupied Bandwidth
- Power State : High

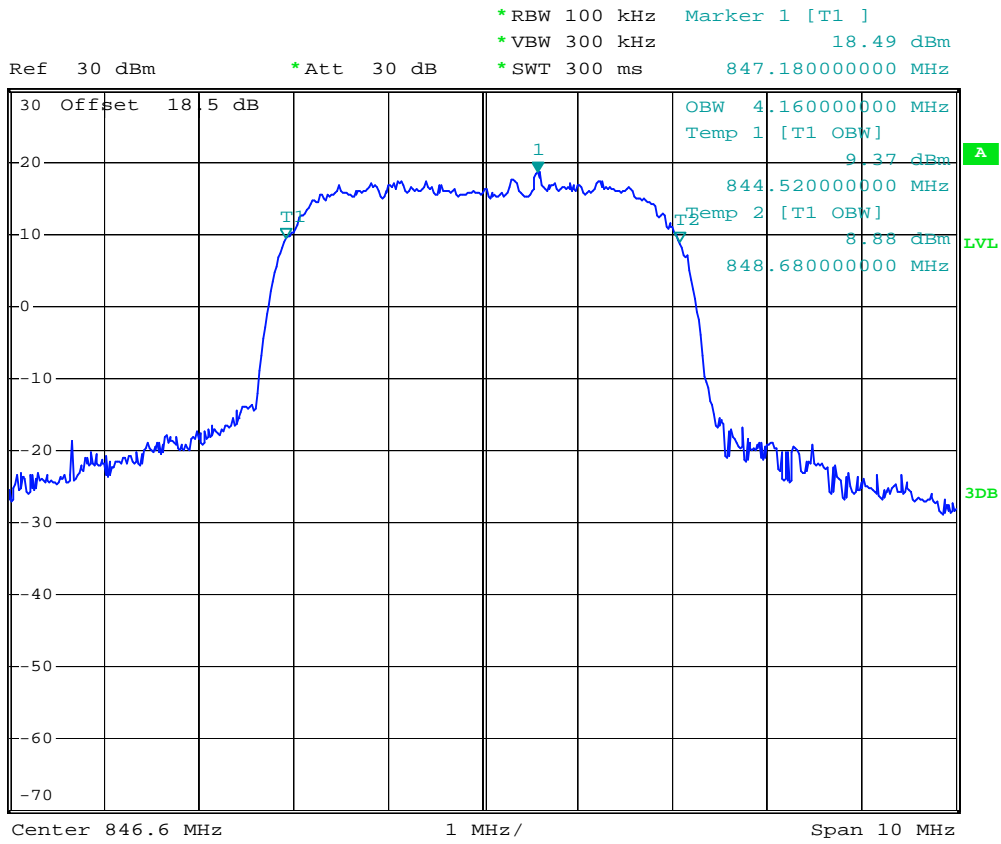

Date: 21.FEB.2008 19:07:55



- Test Mode : WCDMA Band V (HSDPA) CH4132 26dB Bandwidth
- Power State : High

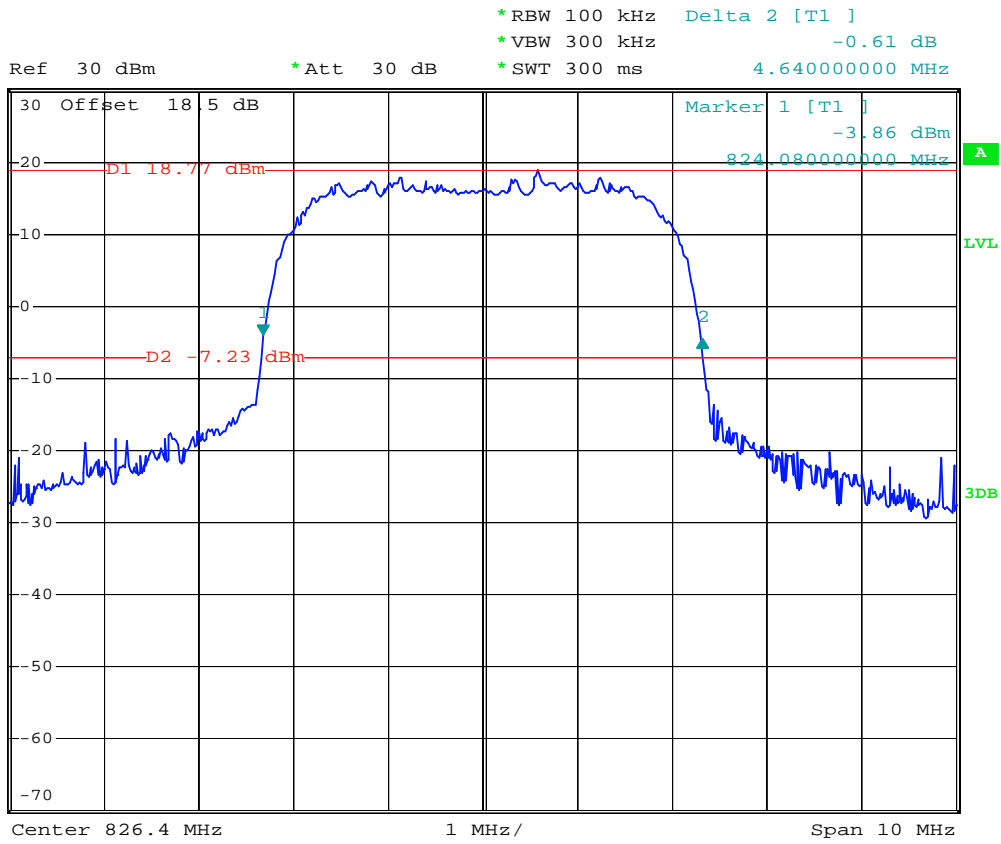

Date: 21.FEB.2008 19:03:01



- Test Mode : WCDMA Band V (HSDPA) CH4182 26dB Bandwidth
- Power State : High

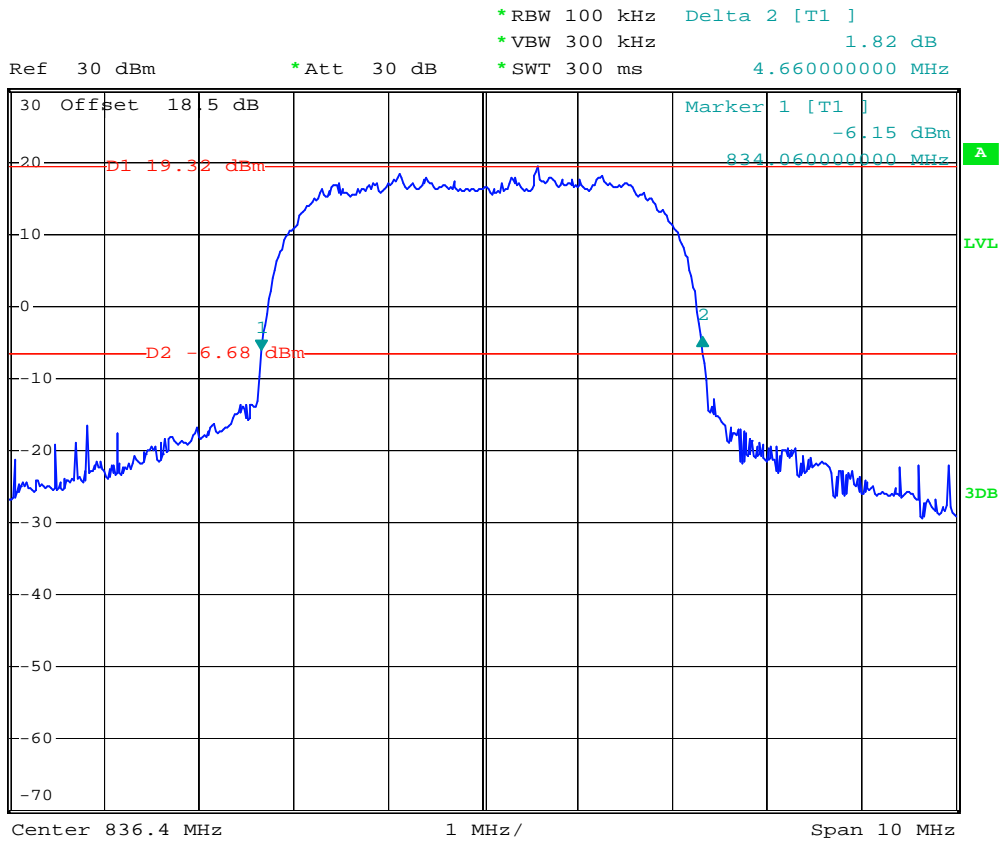

Date: 21.FEB.2008 19:04:44



- Test Mode : WCDMA Band V (HSDPA) CH4233 Higher Band Edge
- Power State : High

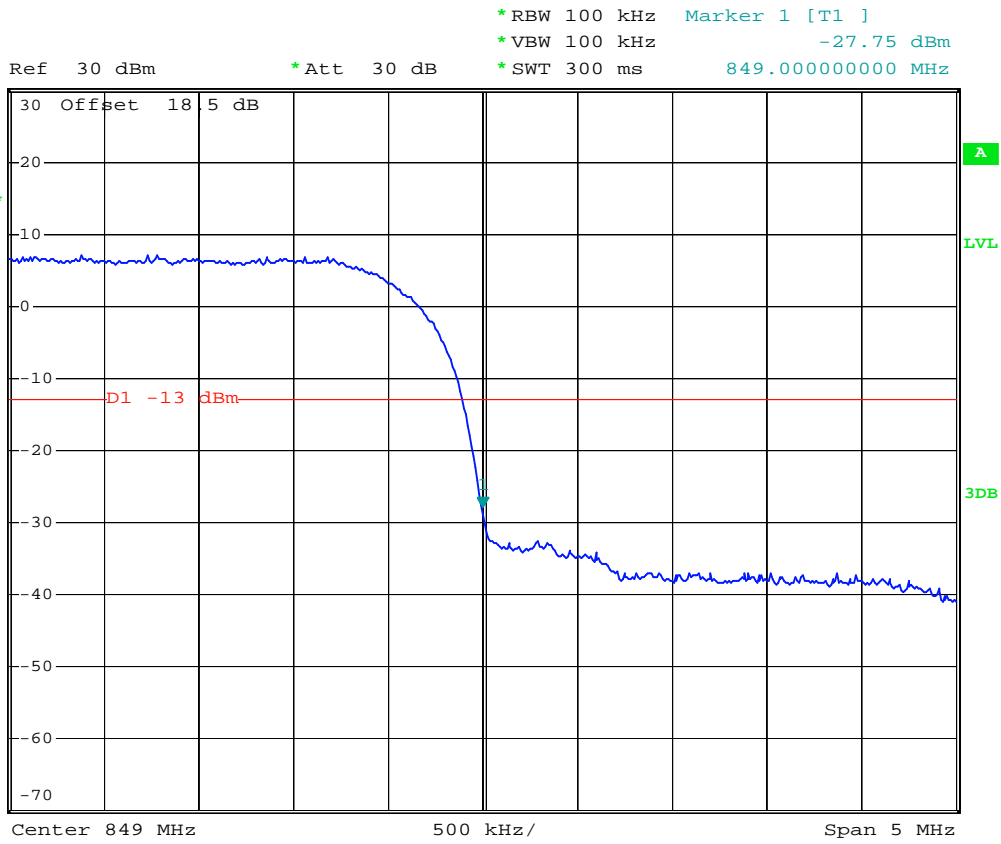

Date: 21.FEB.2008 19:17:58



- Test Mode : WCDMA Band II CH9262 99% Occupied Bandwidth
- Power State : High

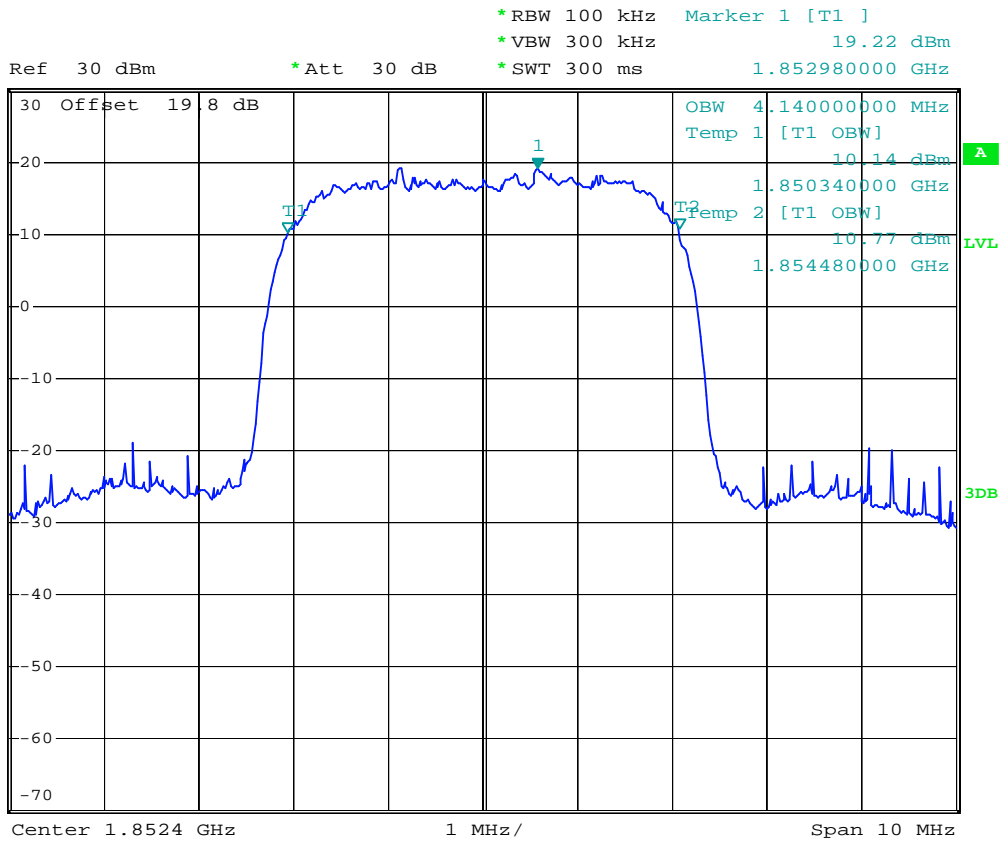

Date: 21.FEB.2008 22:08:29



- Test Mode : WCDMA Band II CH9262 26dB Bandwidth
- Power State : High

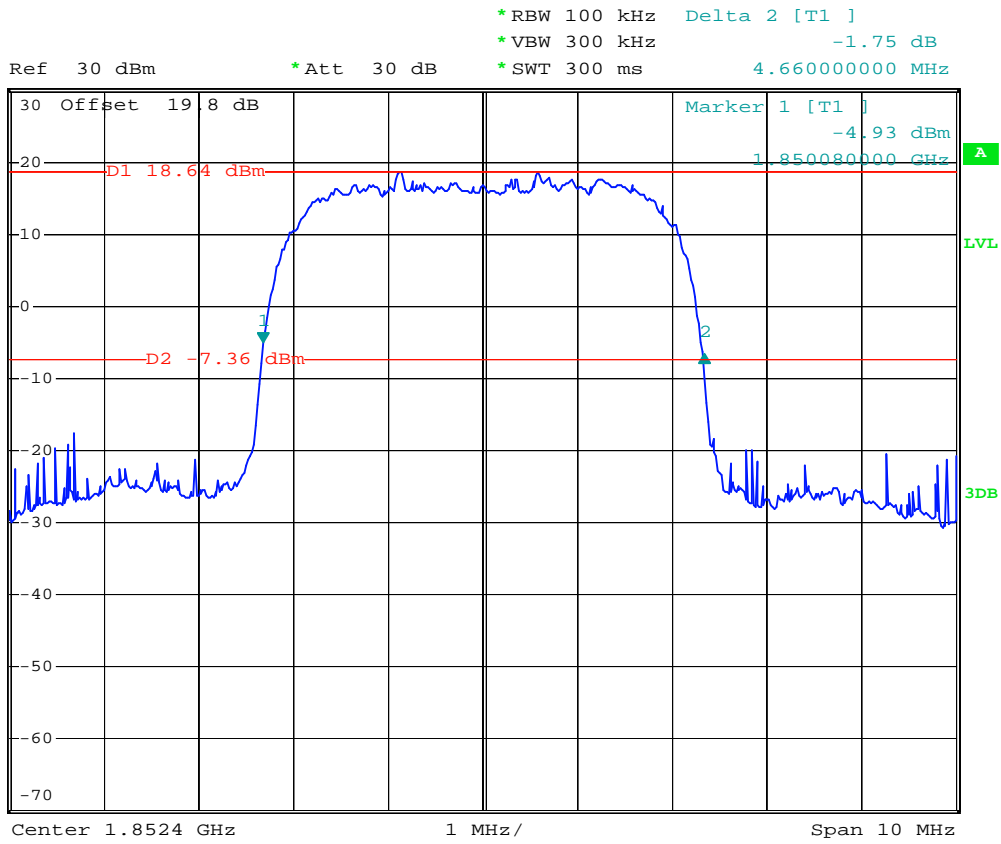

Date: 21.FEB.2008 22:04:01



- Test Mode : WCDMA Band II CH9400 26dB Bandwidth
- Power State : High

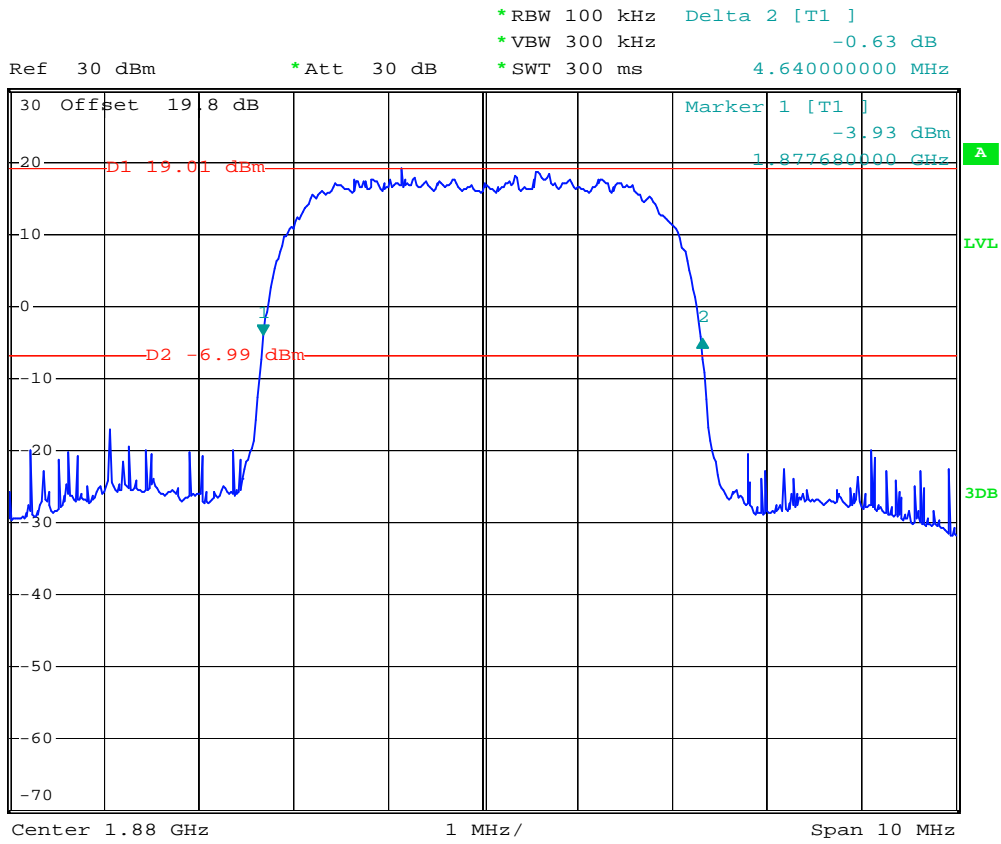

Date: 21.FEB.2008 22:05:07



- Test Mode : WCDMA Band II CH9538 26dB Bandwidth
- Power State : High

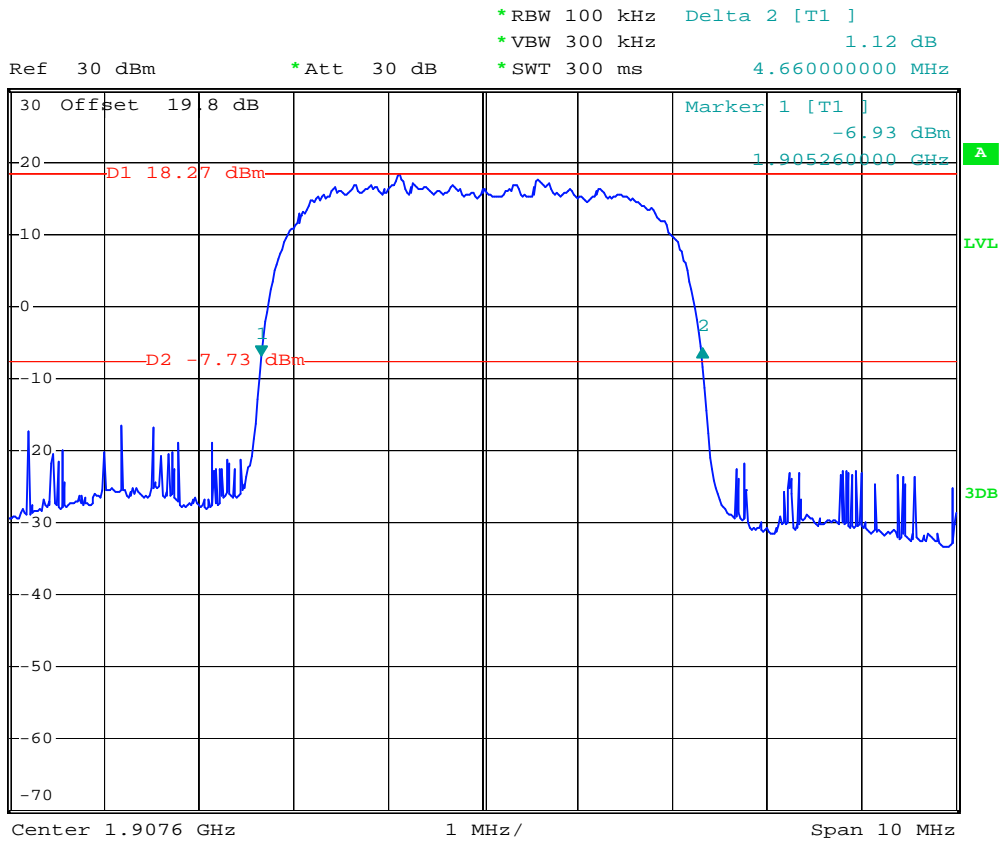

Date: 21.FEB.2008 22:06:40



- Test Mode : WCDMA Band II CH9538 Higher Band Edge
- Power State : High



Ref 30 dBm *Att 30 dB *RBW 100 kHz Marker 1 [T1]
*VBW 100 kHz -30.08 dBm
*SWT 300 ms 1.910000000 GHz

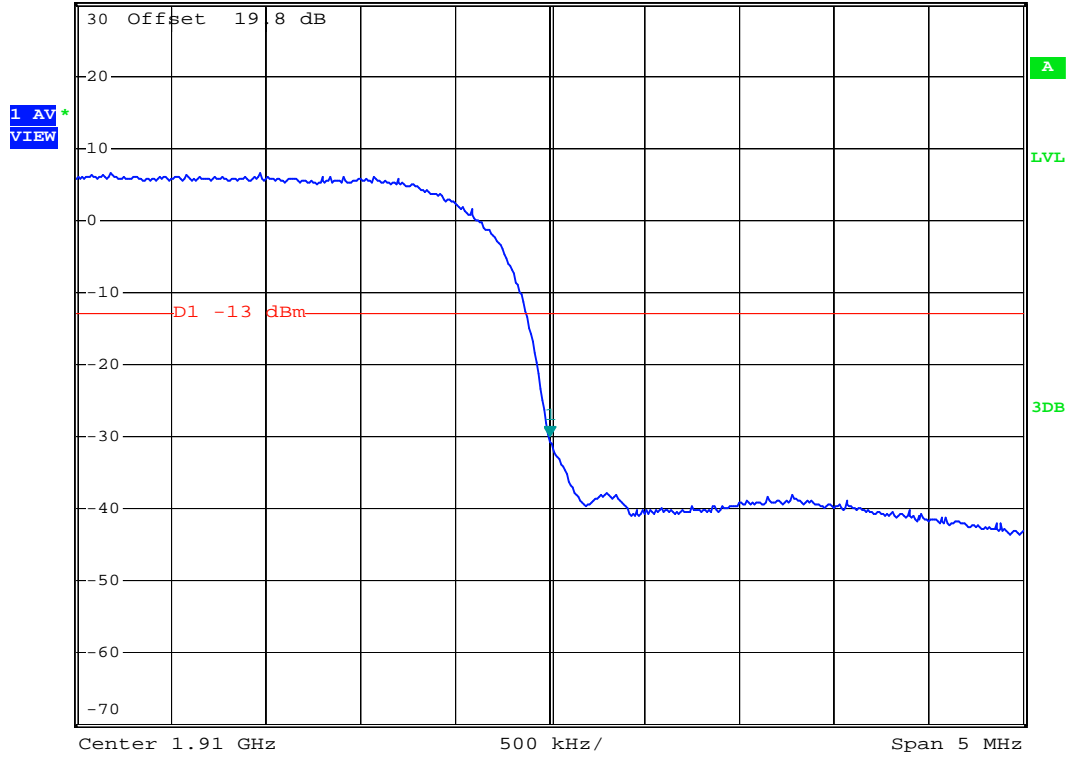

Date: 21.FEB.2008 22:42:48



- Mode 4
- Test Mode : WCDMA Band II (HSDPA) CH9262 Lower Band Edge
- Power State : High

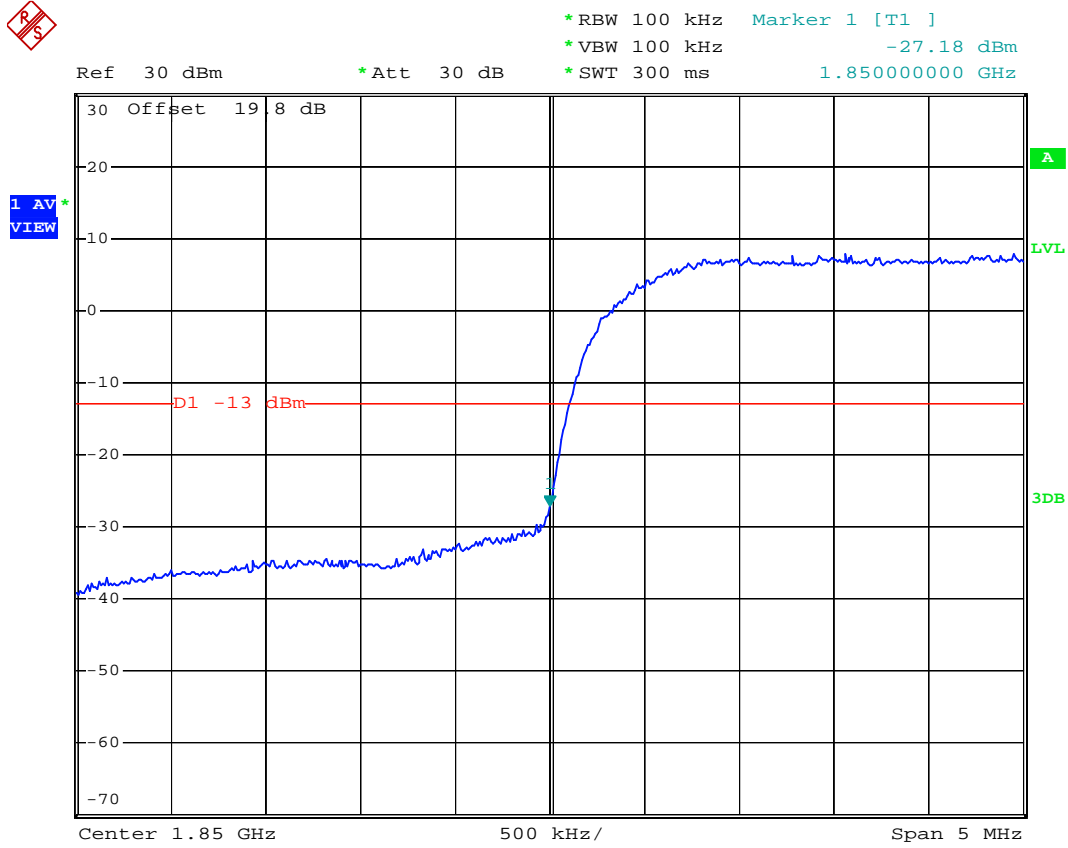

Date: 21.FEB.2008 19:48:32



- Test Mode : WCDMA Band II (HSDPA) CH9538 99% Occupied Bandwidth
- Power State : High

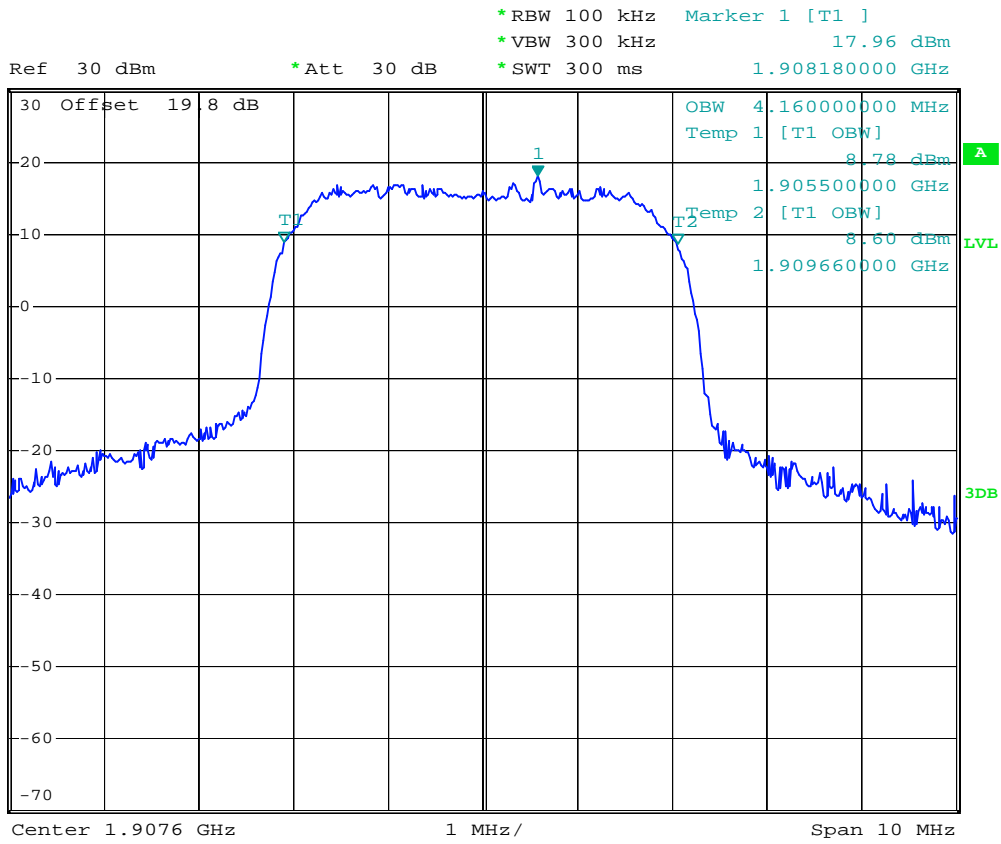

Date: 21.FEB.2008 19:37:57



- Test Mode : WCDMA Band II (HSDPA) CH9262 26dB Bandwidth
- Power State : High

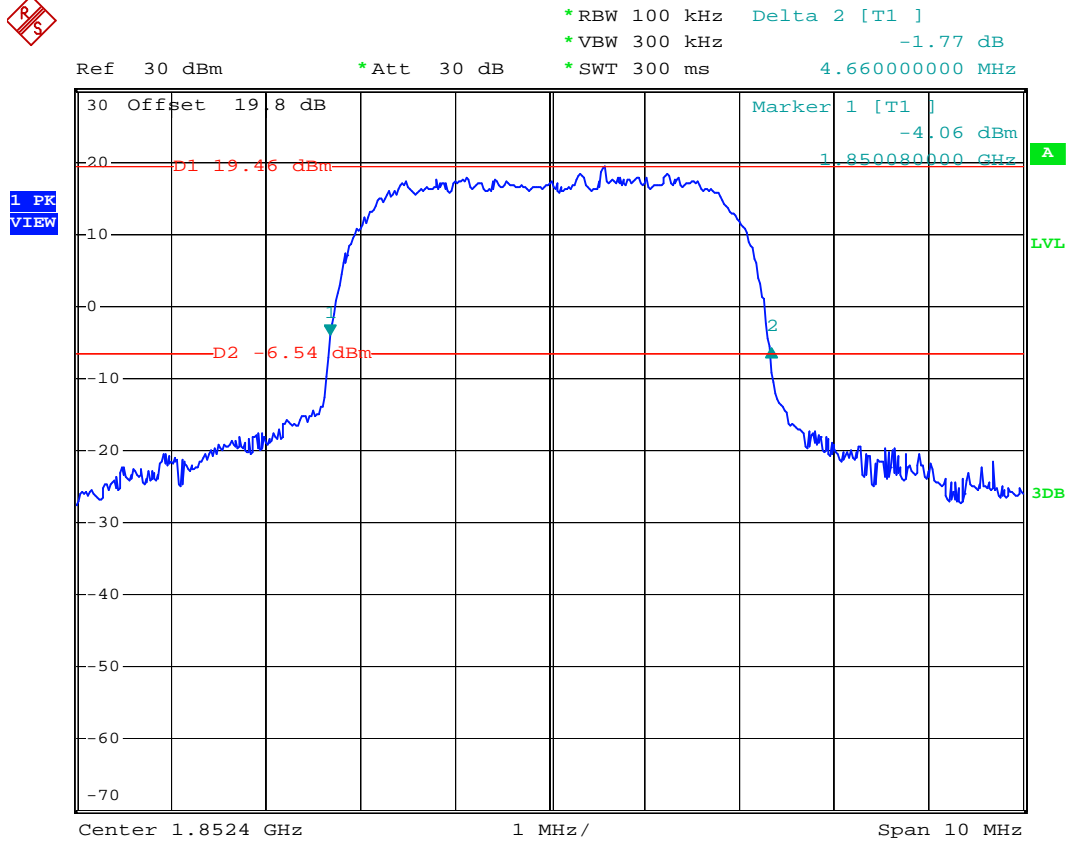

Date: 21.FEB.2008 19:35:23



- Test Mode : WCDMA Band II (HSDPA) CH9400 26dB Bandwidth
- Power State : High

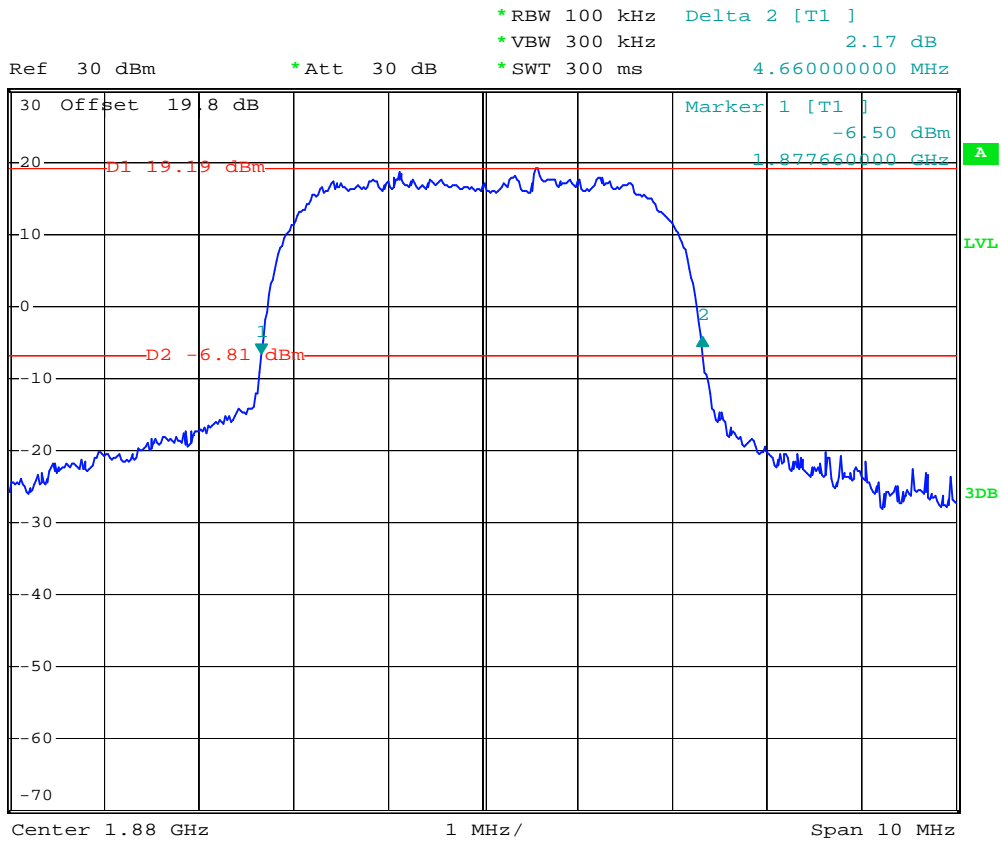

Date: 21.FEB.2008 19:34:11



- Test Mode : WCDMA Band II (HSDPA) CH9538 26dB Bandwidth
- Power State : High



*RBW 100 kHz Delta 2 [T1]
 *VBW 300 kHz 0.70 dB
 *SWT 300 ms 4.660000000 MHz

Ref 30 dBm

*Att 30 dB

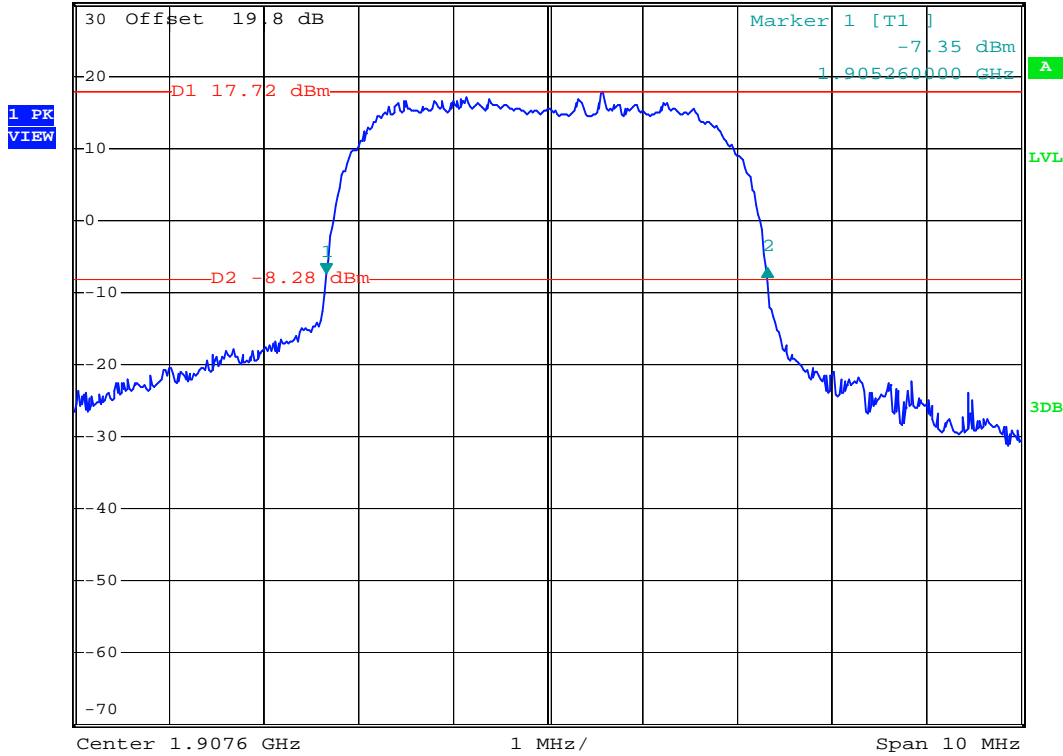

Date: 21.FEB.2008 19:33:05



- Test Mode : WCDMA Band II (HSDPA) CH9538 Higher Band Edge
- Power State : High

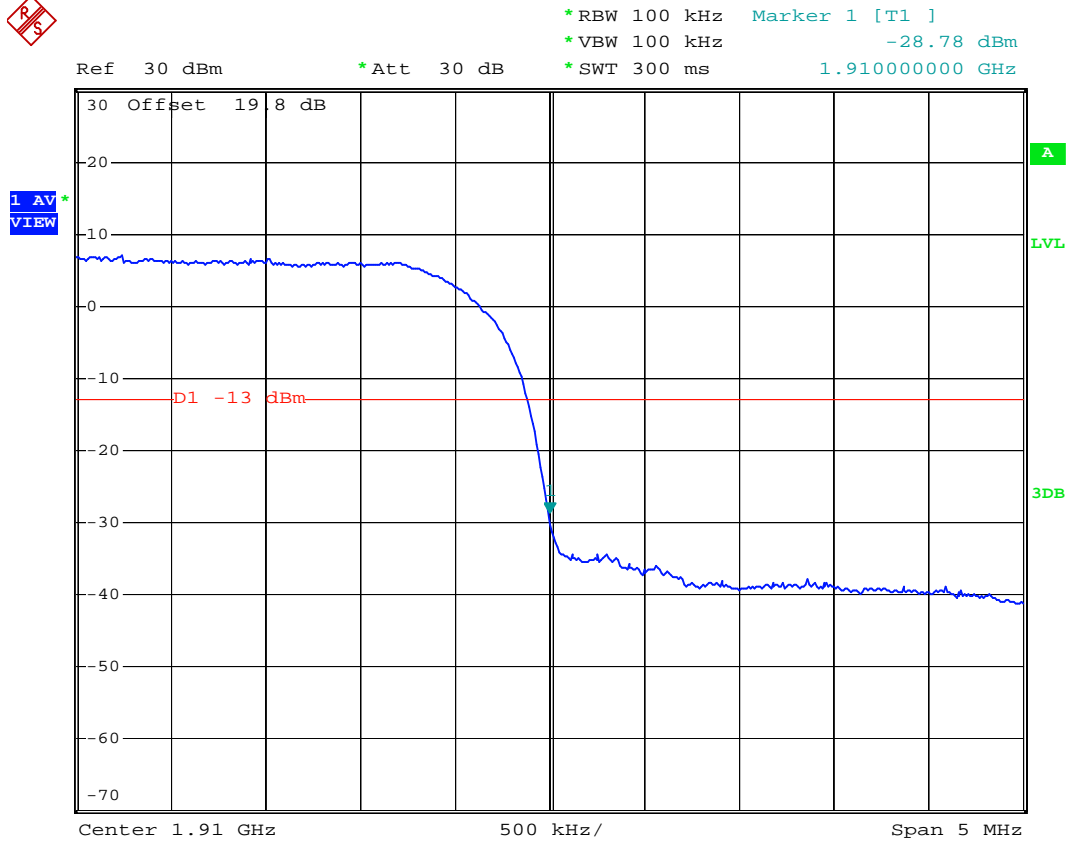

Date: 21.FEB.2008 19:51:42

4.5 Conducted Emission

4.5.1 Measurement Instruments

As described in chapter 5 of this test report.

4.5.2 Test Procedure

- a. The EUT was connected to Spectrum Analyzer and Base Station via power divider.
- b. The middle channel for the highest RF power within the transmitting frequency was measured.
- c. The conducted spurious emission for the whole frequency range was taken.

4.5.3 Test Setup Layout

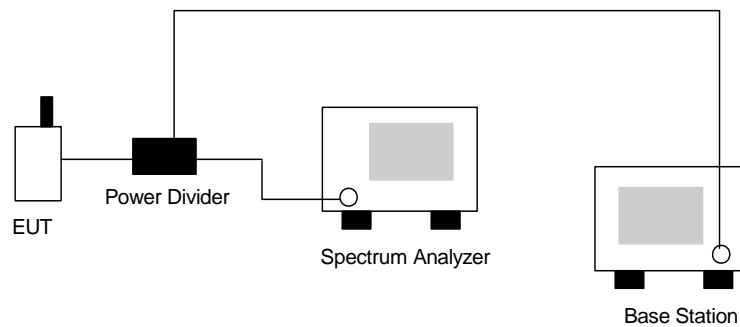



4.5.4 Test Result

- Mode 1
- Test Mode : WCDMA Band V CH4182
- Frequency Range : 30M-1G

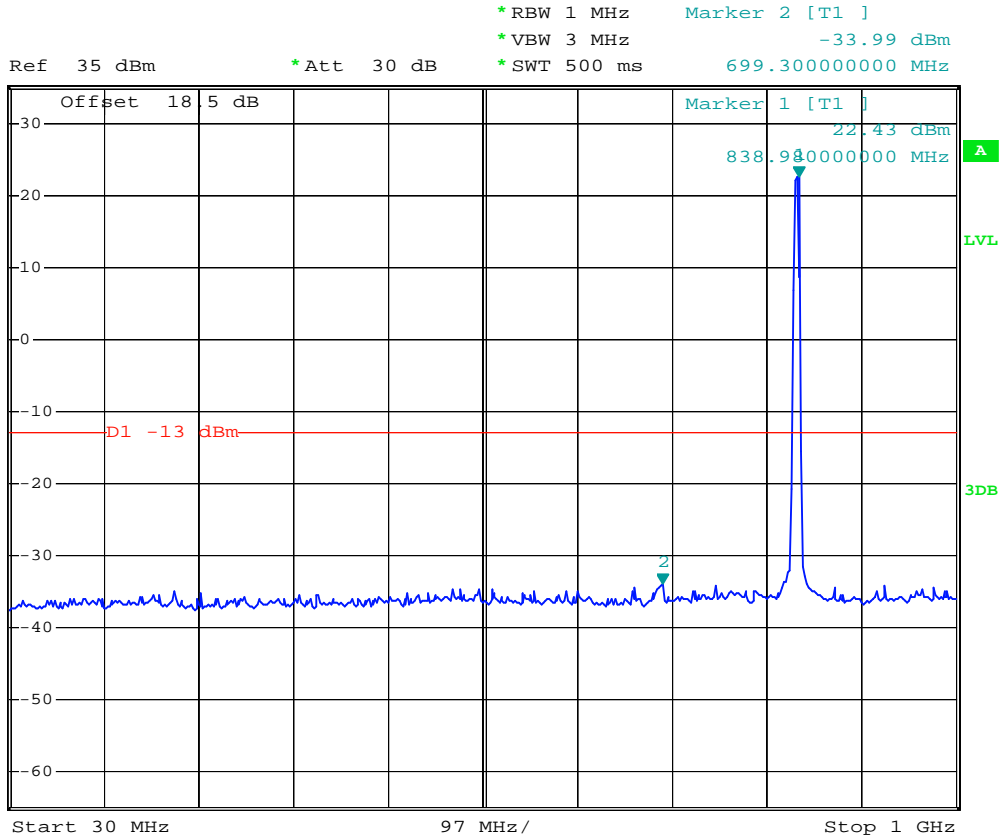

Date: 22.FEB.2008 00:26:01



- Test Mode : WCDMA Band V CH4182
- Frequency Range : 1G-3G



Ref 0 dBm *Att 0 dB *RBW 1 MHz Marker 2 [T1]
 *VBW 3 MHz -58.49 dBm
 *SWT 500 ms 1.672000000 GHz

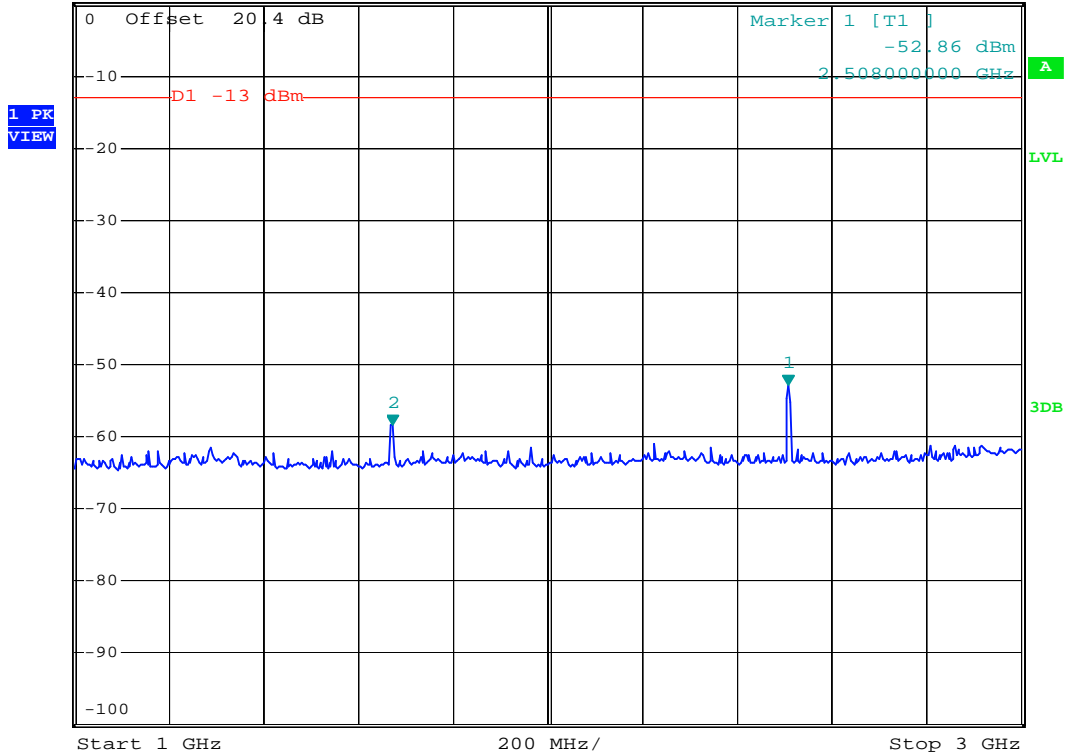

Date: 22.FEB.2008 00:21:21



- Test Mode : WCDMA Band V CH4182
- Frequency Range : 3G-7G



*RBW 1 MHz Marker 1 [T1]
*VBW 3 MHz -50.71 dBm
*SWT 500 ms 3.344000000 GHz

Ref 0 dBm

*Att 0 dB

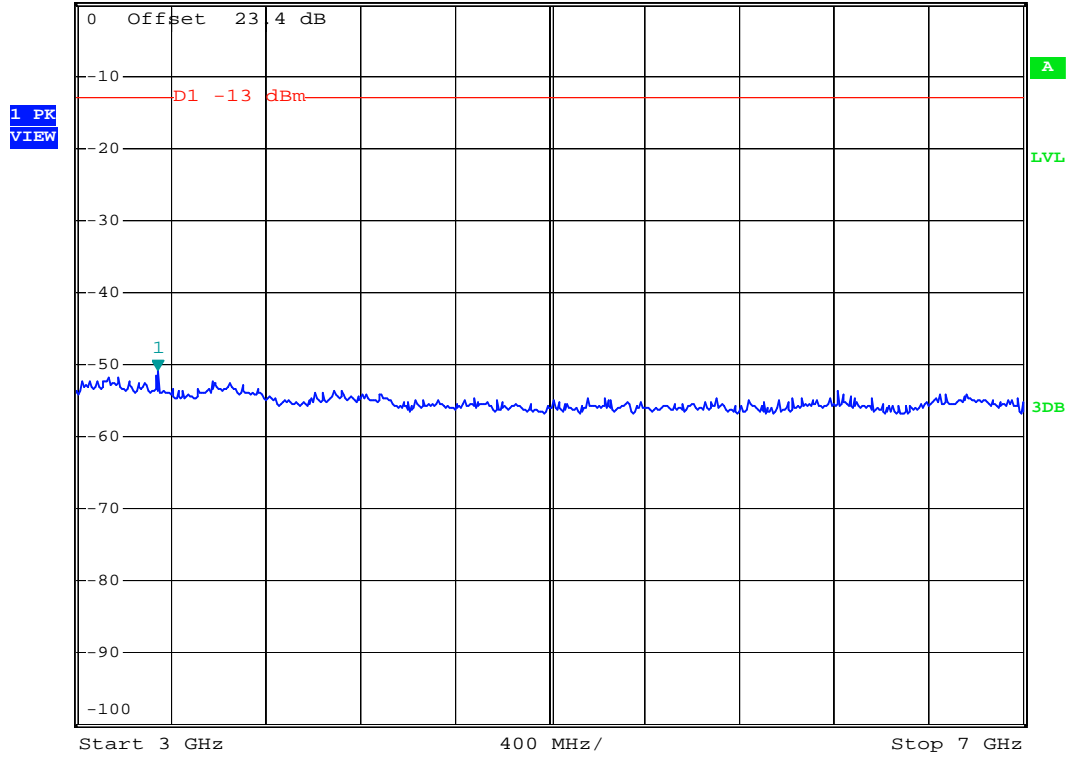

Date: 22.FEB.2008 00:07:41



- Mode 2
- Test Mode : WCDMA Band V (HSDPA) CH4182
- Frequency Range : 30M-1G



Ref 35 dBm *Att 30 dB *RBW 1 MHz Marker 2 [T1]
 *VBW 3 MHz -33.38 dBm
 *SWT 500 ms 697.360000000 MHz

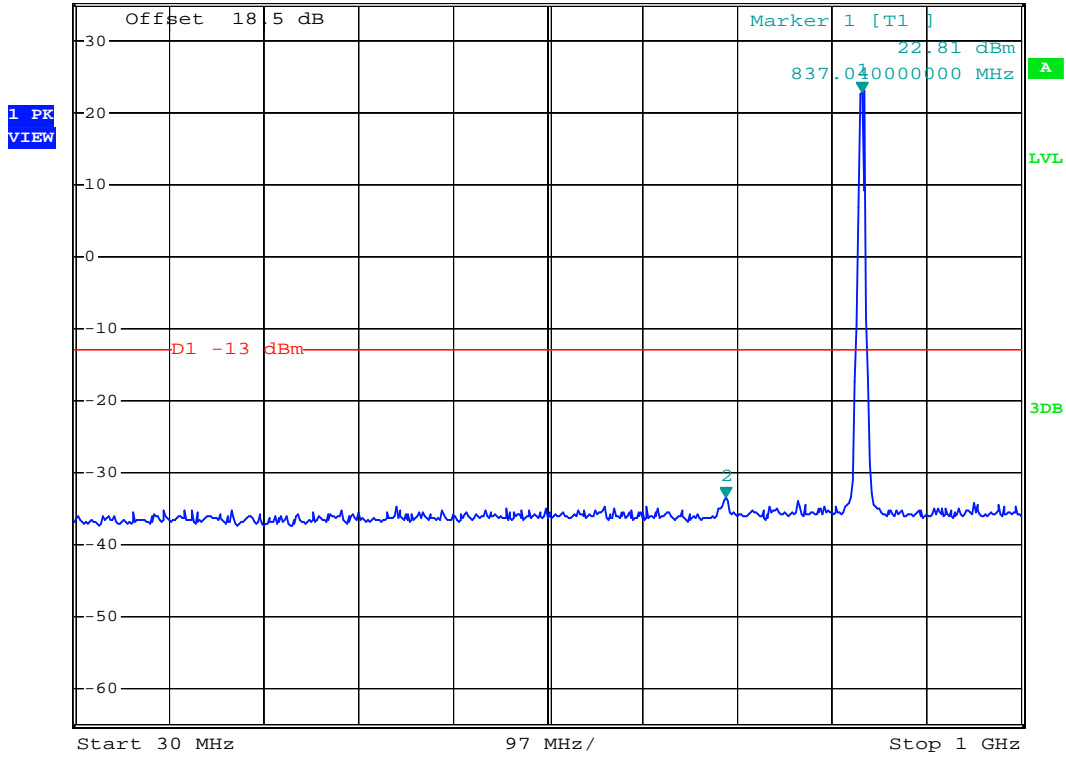

Date: 22.FEB.2008 00:27:09



- Test Mode : WCDMA Band V (HSDPA) CH4182
- Frequency Range : 1G-3G

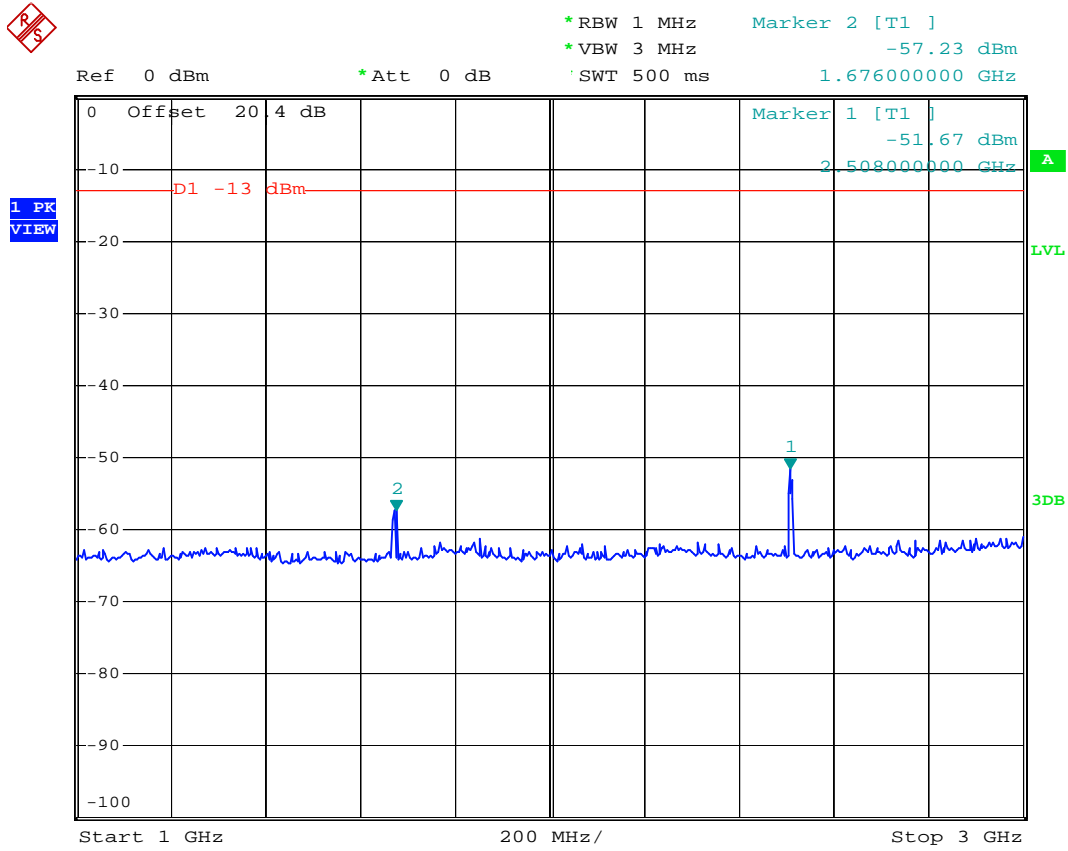

Date: 22.FEB.2008 00:20:07



- Test Mode : WCDMA Band V (HSDPA) CH4182
- Frequency Range : 3G-7G

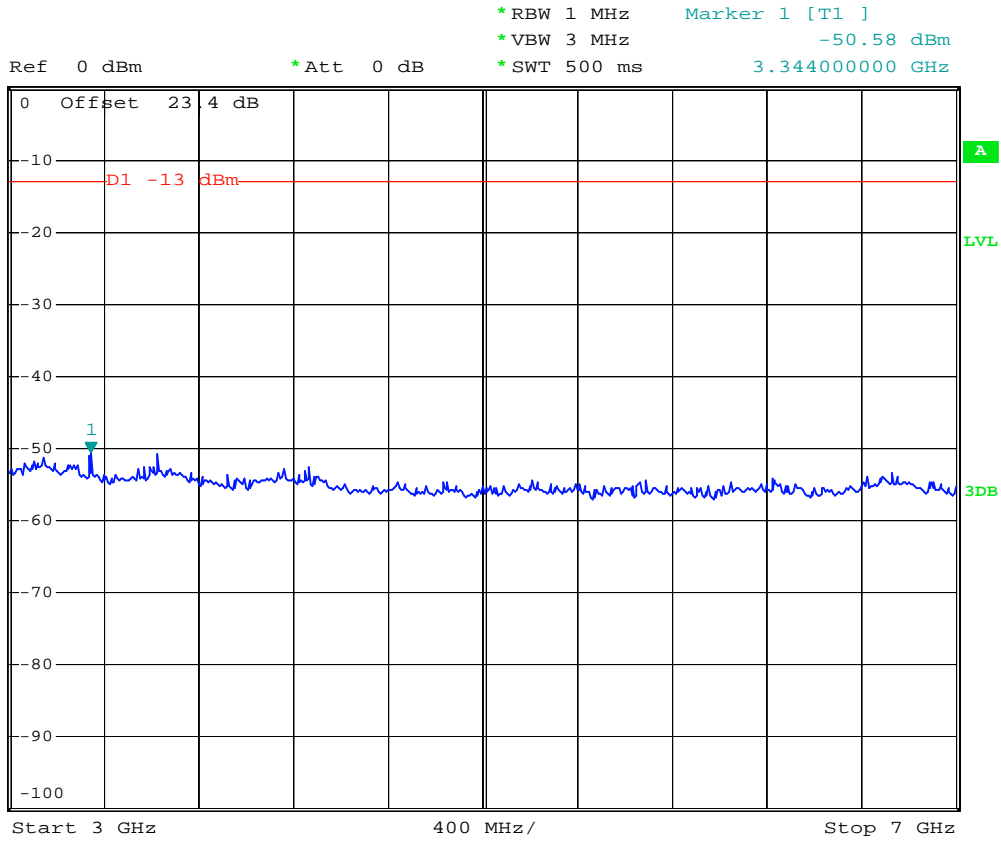

Date: 22.FEB.2008 00:06:38



- Test Mode : WCDMA Band V (HSDPA) CH4182
- Frequency Range : 7G-9G

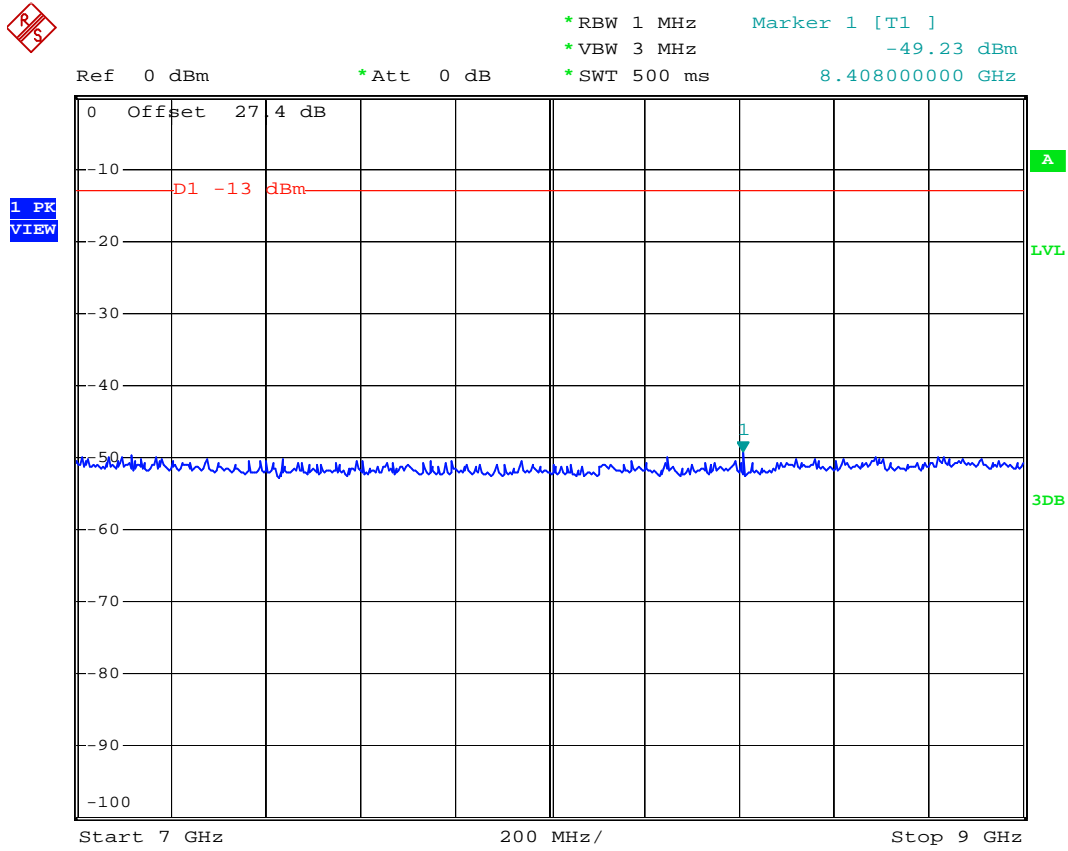

Date: 22.FEB.2008 00:05:39



- Mode 3
- Test Mode : WCDMA Band II CH9400
- Frequency Range : 30M-1G



Ref 35 dBm *Att 30 dB *RBW 1 MHz Marker 1 [T1]
 *VBW 3 MHz -33.82 dBm
 *SWT 500 ms 697.36000000 MHz

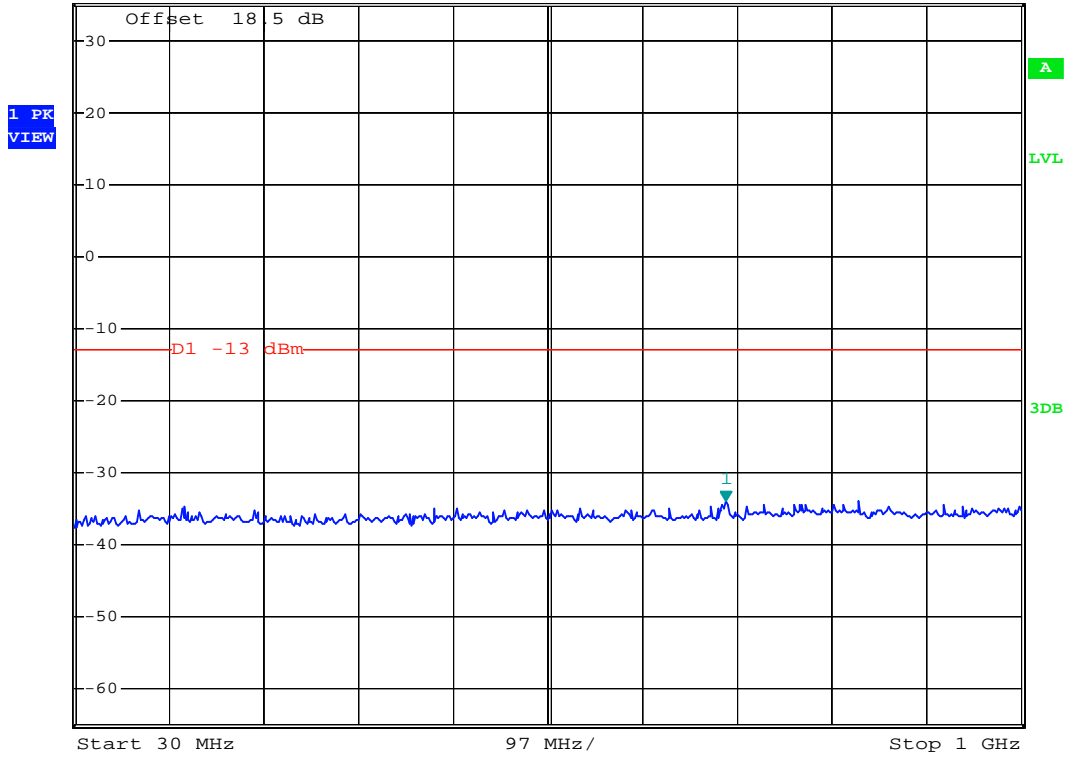

Date: 22.FEB.2008 00:28:36



- Test Mode : WCDMA Band II CH9400
- Frequency Range : 1G-3G



Ref 35 dBm *Att 30 dB *RBW 1 MHz Marker 2 [T1]
 *VBW 3 MHz -30.74 dBm
 *SWT 500 ms 2.972000000 GHz

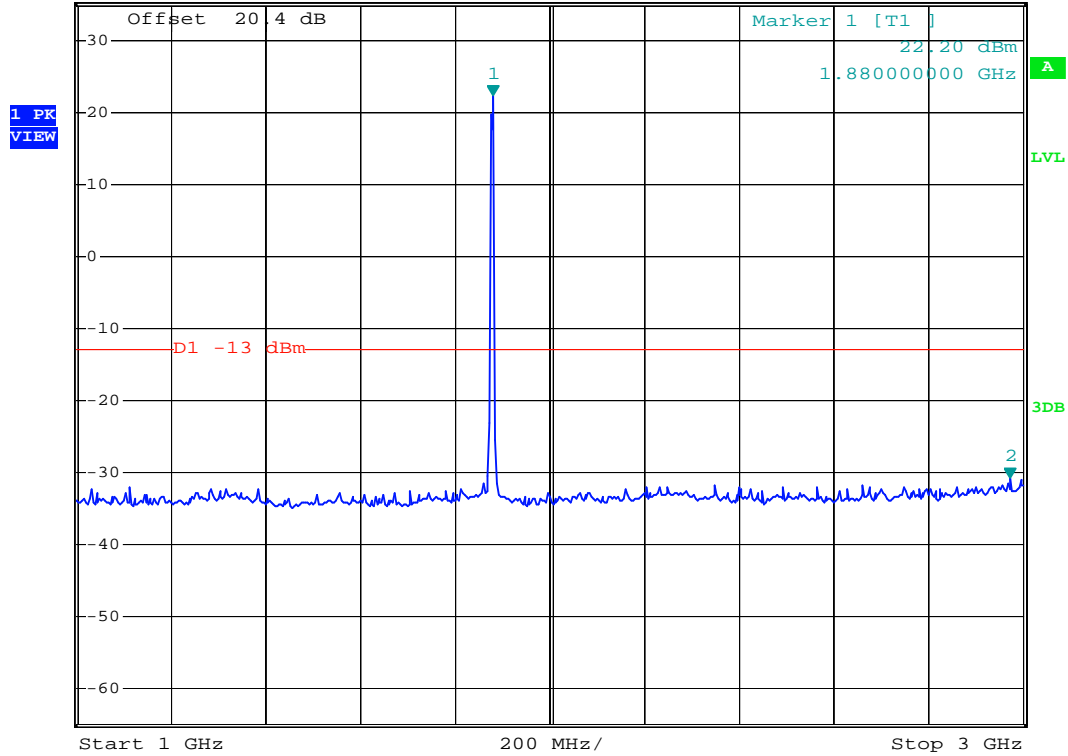

Date: 22.FEB.2008 00:15:28



- Test Mode : WCDMA Band II CH9400
- Frequency Range : 3G-7G

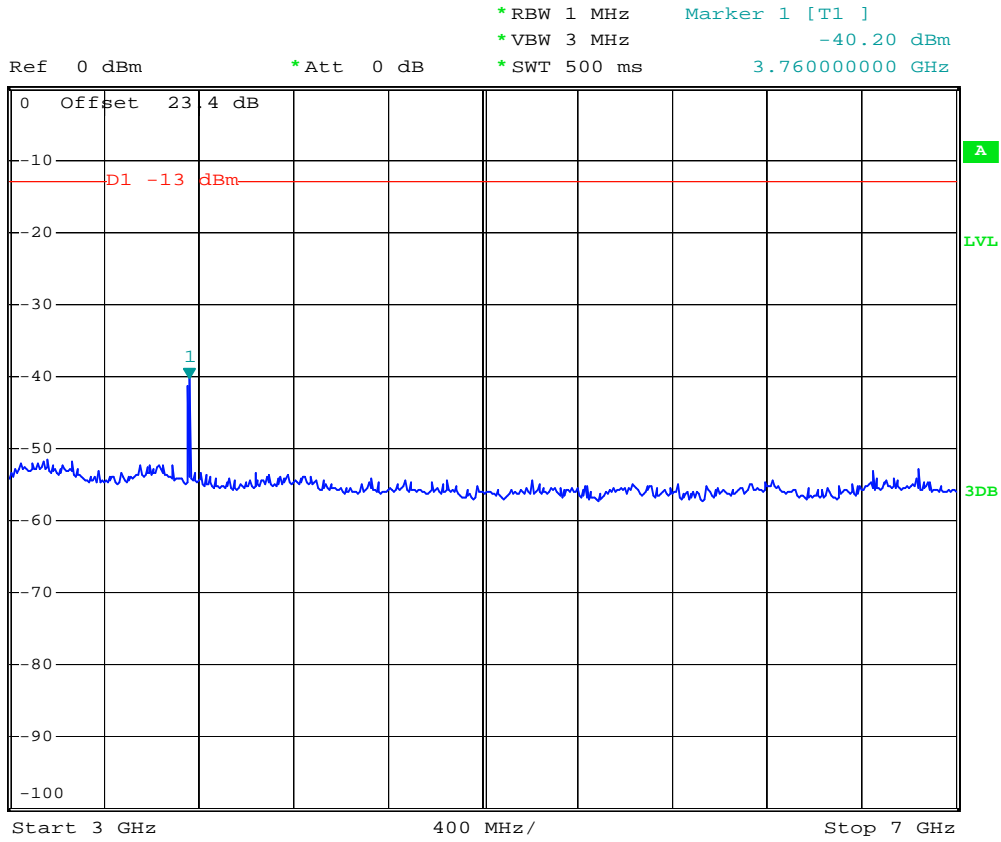

Date: 22.FEB.2008 00:10:08



- Test Mode : WCDMA Band II CH9400
- Frequency Range : 7G-13.6G



Ref 0 dBm *Att 0 dB *RBW 1 MHz Marker 1 [T1]
*VBW 3 MHz -47.45 dBm
*SWT 500 ms 13.468000000 GHz

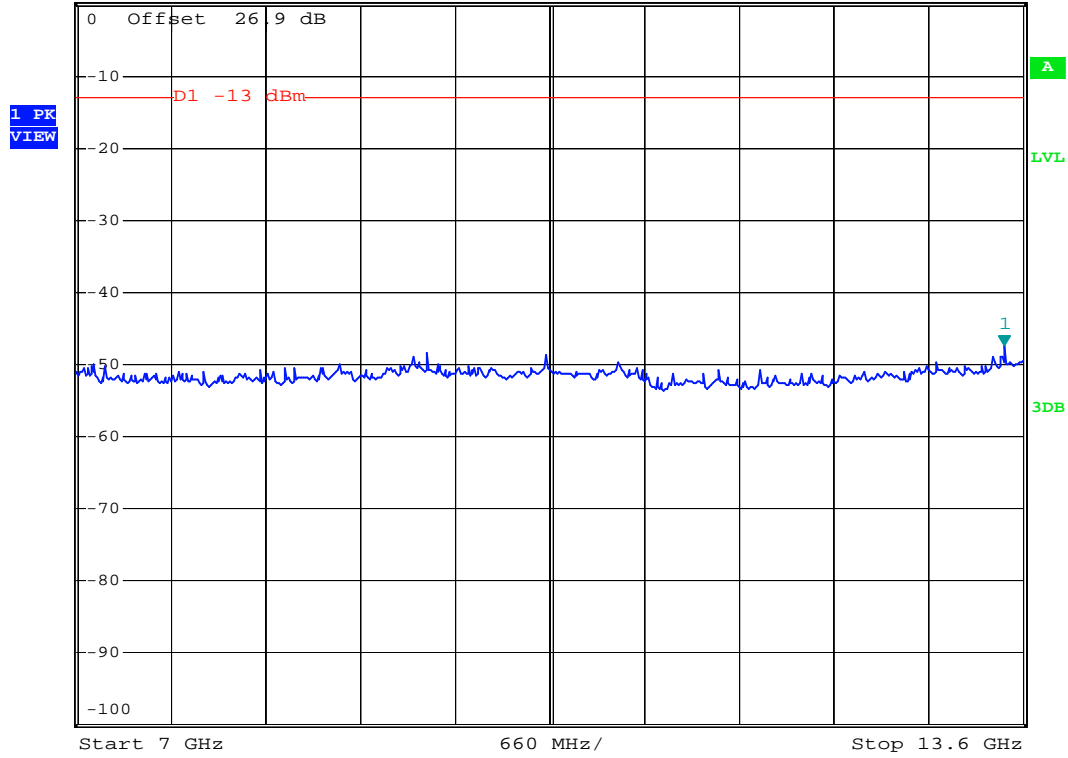

Date: 21.FEB.2008 23:58:41



- Mode 4
- Test Mode : WCDMA Band II (HSDPA) CH9400
- Frequency Range : 30M-1G



Ref 35 dBm *Att 30 dB *RBW 1 MHz Marker 1 [T1]
 *VBW 3 MHz -32.83 dBm
 *SWT 500 ms 831.22000000 MHz

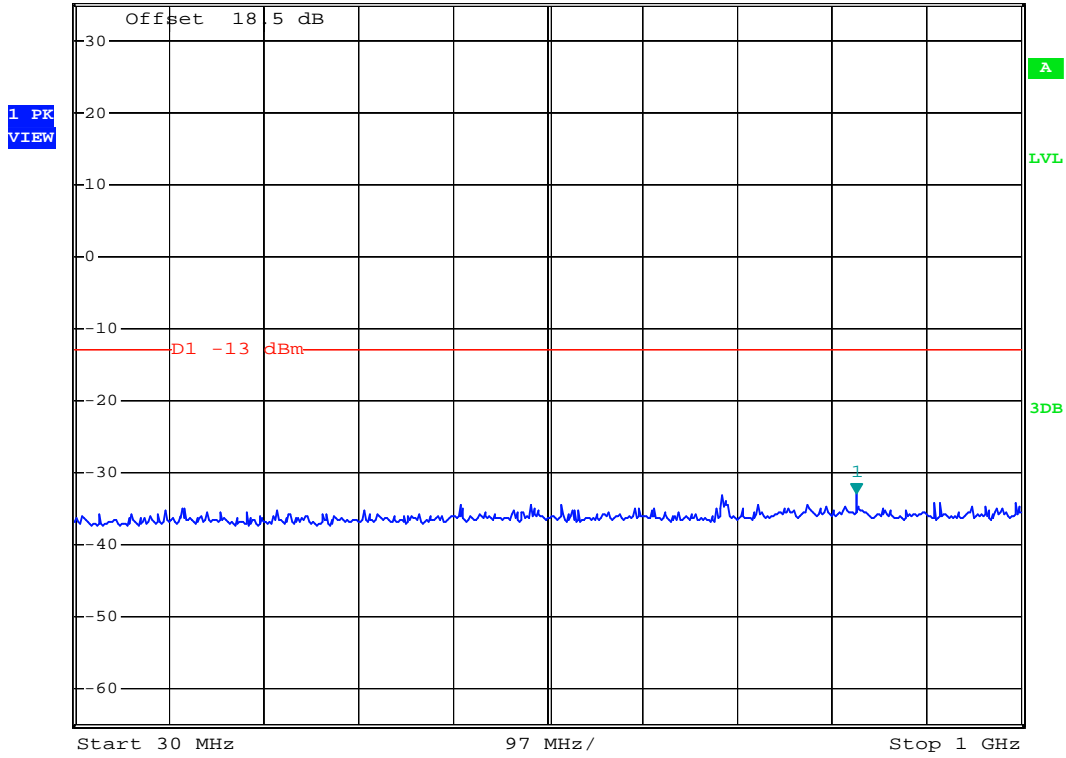

Date: 22.FEB.2008 00:28:03



- Test Mode : WCDMA Band II (HSDPA) CH9400
- Frequency Range : 1G-3G



Ref 35 dBm *Att 30 dB *RBW 1 MHz Marker 2 [T1]
 *VBW 3 MHz -31.34 dBm
 *SWT 500 ms 2.972000000 GHz

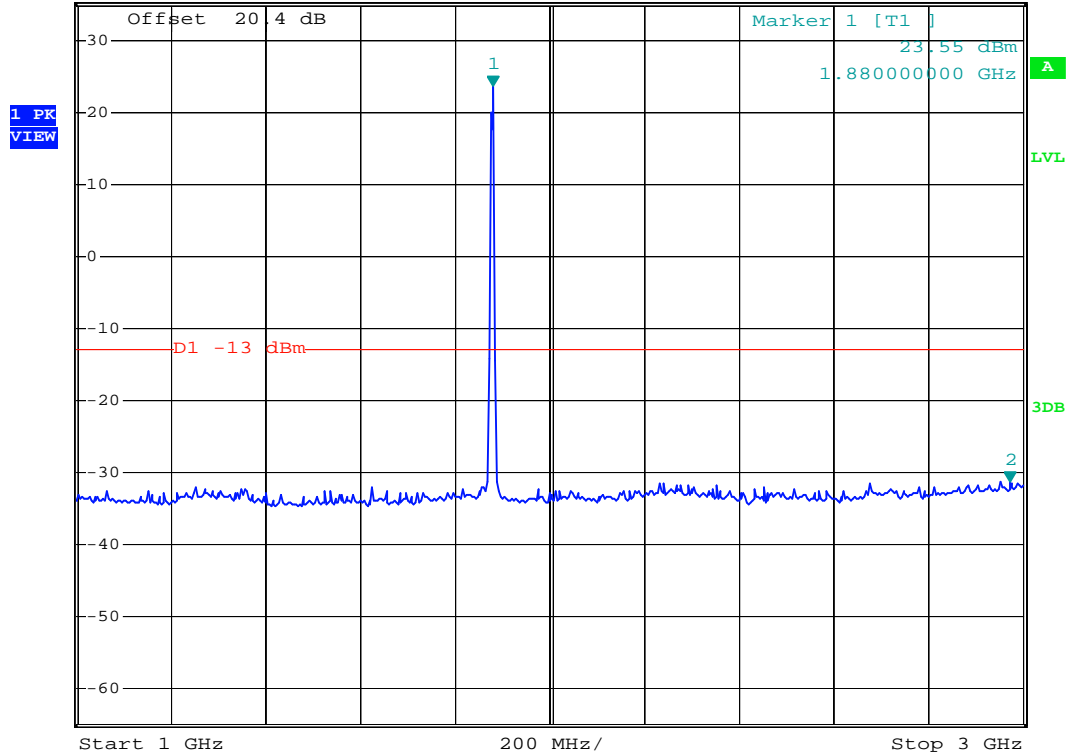

Date: 22.FEB.2008 00:13:44



- Test Mode : WCDMA Band II (HSDPA) CH9400
- Frequency Range : 3G-7G

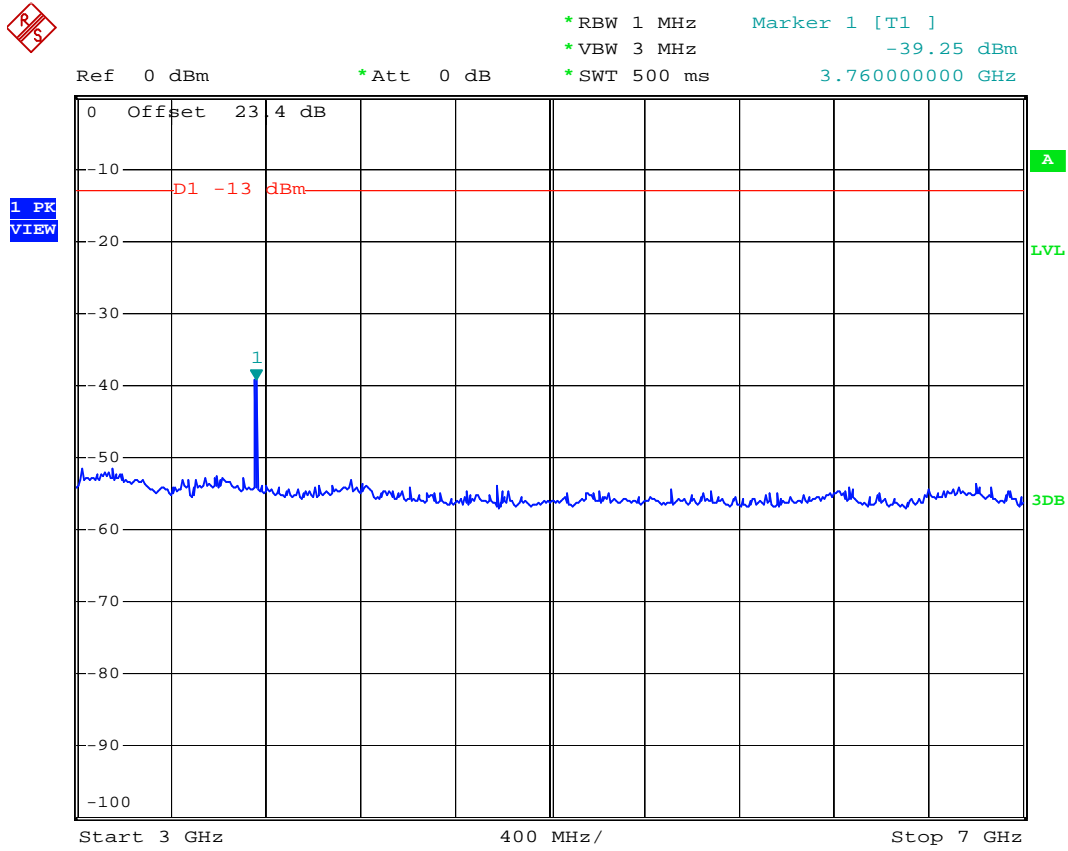

Date: 22.FEB.2008 00:10:43



- Test Mode : WCDMA Band II (HSDPA) CH9400
- Frequency Range : 7G-13.6G

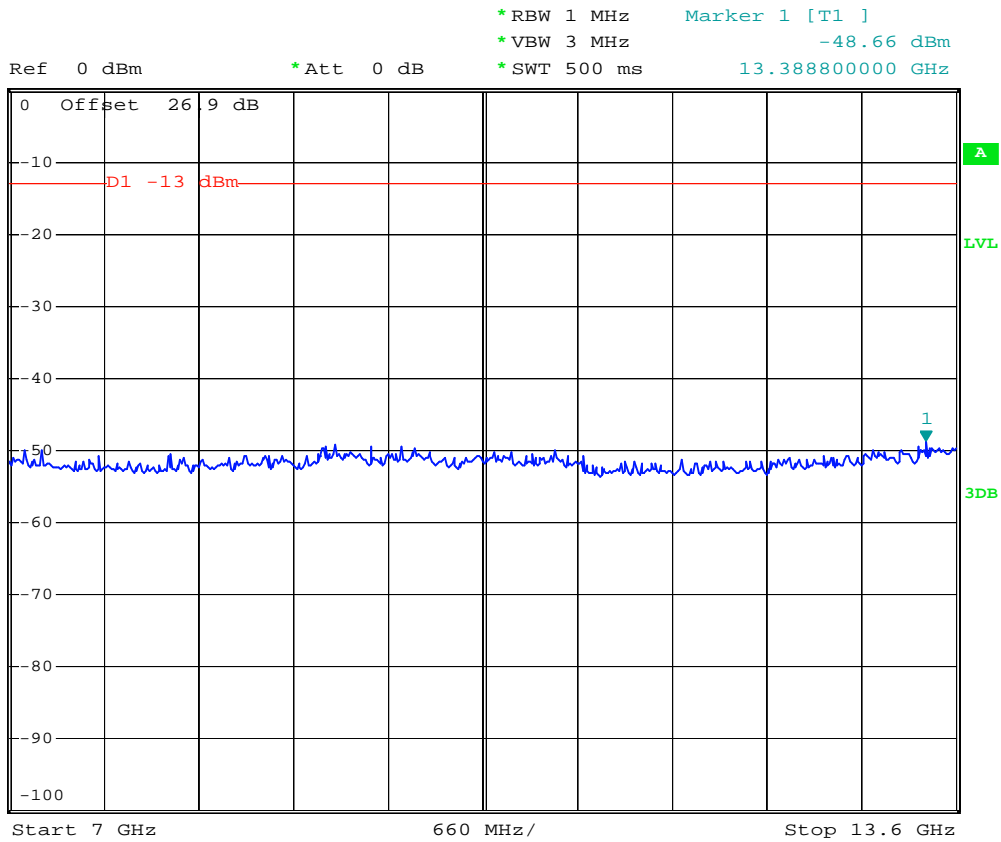

Date: 21.FEB.2008 23:51:15



- Test Mode : WCDMA Band II (HSDPA) CH9400
- Frequency Range : 13.6G-19.1G

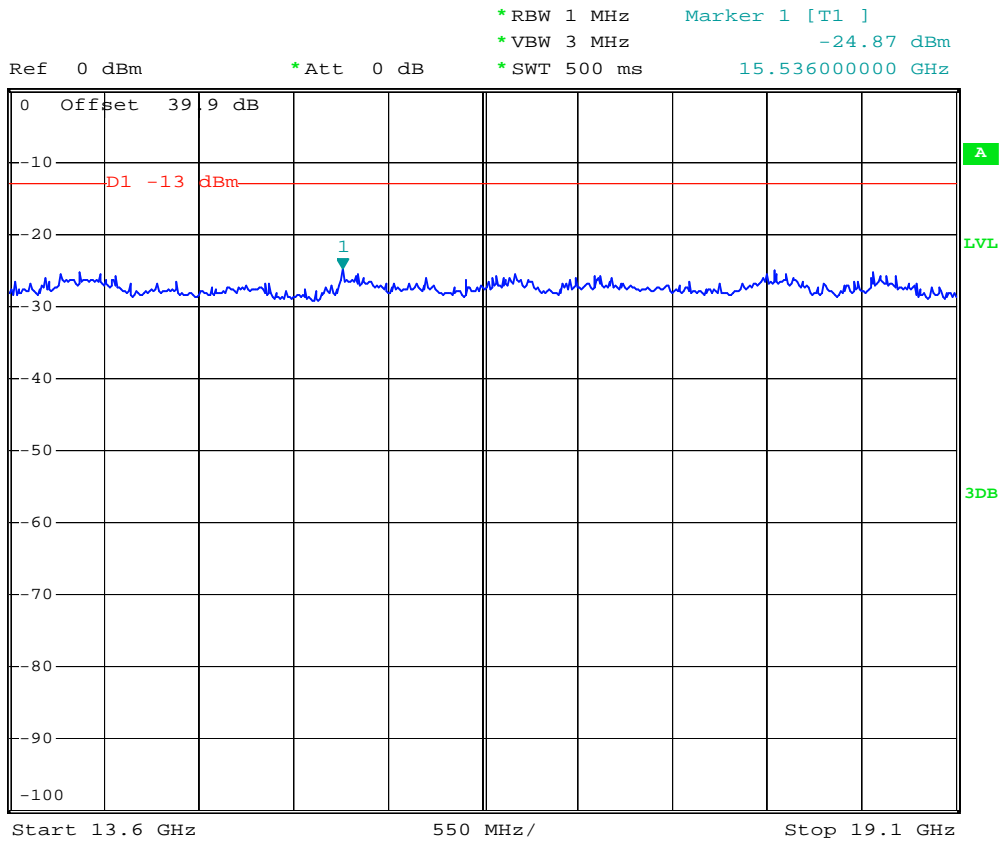

Date: 22.FEB.2008 00:01:19

4.6 Field Strength of Spurious Radiation

Equivalent isotropic radiated Power Measurements by substitution method according to ANSI/TIA/EIA-603-C.

4.6.1 Measurement Instruments

As described in chapter 5 of this test report.

4.6.2 Test Procedure

- a. The EUT was placed on a rotatable wooden table with 0.8 meter about ground.
- b. The EUT was set 3 meters from the receiving antenna which was mounted on the antenna tower.
- c. The table was rotated 360 degrees to determine the position of the highest spurious emission.
- d. The height of the receiving antenna is varied between one meter and four meters to reach the maximum spurious emission for both horizontal and vertical polarizations.
- e. Taking the record of maximum spurious emission.
- f. A Horn antenna was substituted in place of the EUT and was driven by a signal generator.
- g. Tune the output power of signal generator to the same emission level with EUT maximum spurious emission.
- h. Taking the record of output power at antenna port.
- i. Repeat step 7 to step 8 for another polarization.
- j. Emission level (dBm) = output power + substitution Gain.

4.6.3 Test Setup Layout

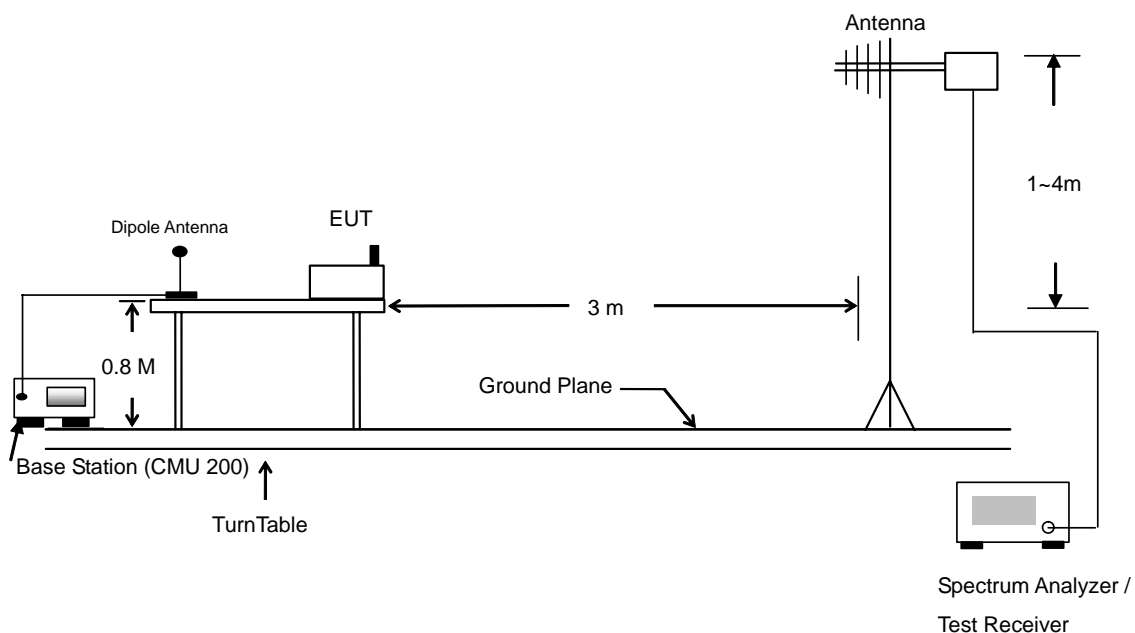



4.6.4 Test Data

4.6.4.1 Mode 1

Horizontal Polarization

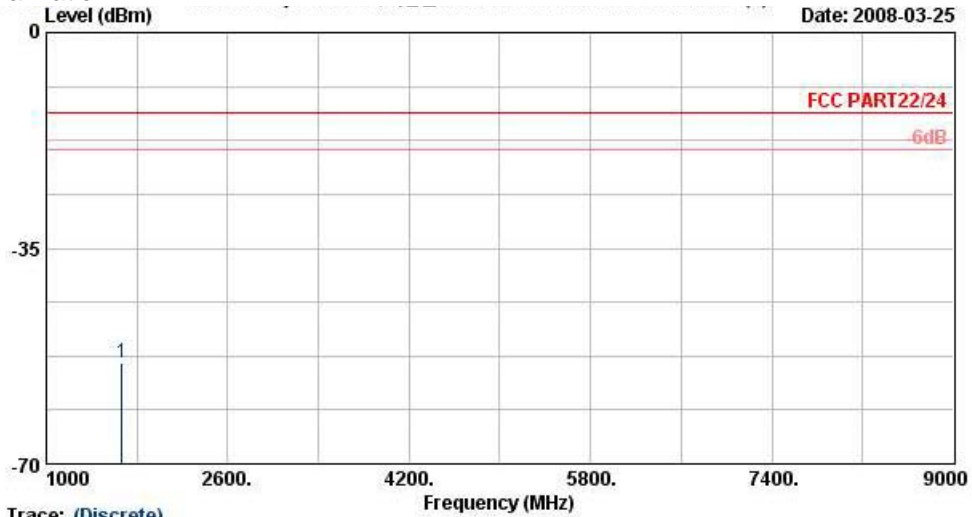

Trace: (Discrete)
 Site : 03CH07-HY
 Condition : FCC PART22/24 HF-EIRP(080306) HORIZONTAL
 EUT : Tablet PC
 Power : 120Wac/60Hz
 Model : FG 812310-01
 Mode : WCDMA Band V Link ; Ch4182 + Adaptor
 Plane : 180 degree

Frequency (MHz)	ERP (dBm)	Limit (dBm)	SPA Reading (dBm)	S.G. Power (dBm)	TX Cable loss (dB)	TX Antenna Gain (dBi)	Polarization (H/V)	Result
1669	-53.7	-13	-61.75	-52.8	3.39	4.55	H	Pass

Remark : Spurious emissions within 30-1000MHz were found more than 20dB below limit line.



Vertical Polarization

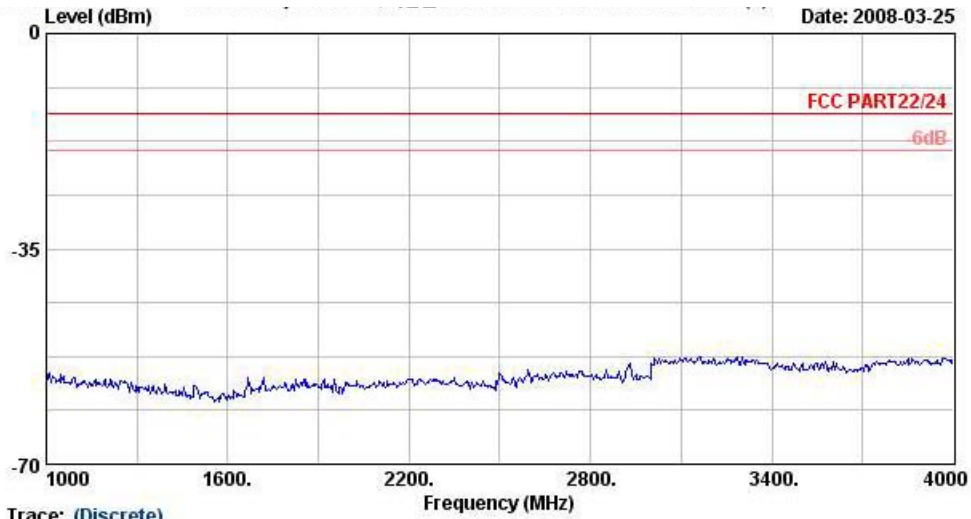

Trace: (Discrete)

Site : 03CH07-HY
Condition : FCC PART22/24 HF-EIRP(080306) VERTICAL
EUT : Tablet PC
Power : 120Vac/60Hz
Model : FG 812310-01
Mode : WCDMA Band V Link ; Ch4182 + Adaptor
Plane : 180 degree

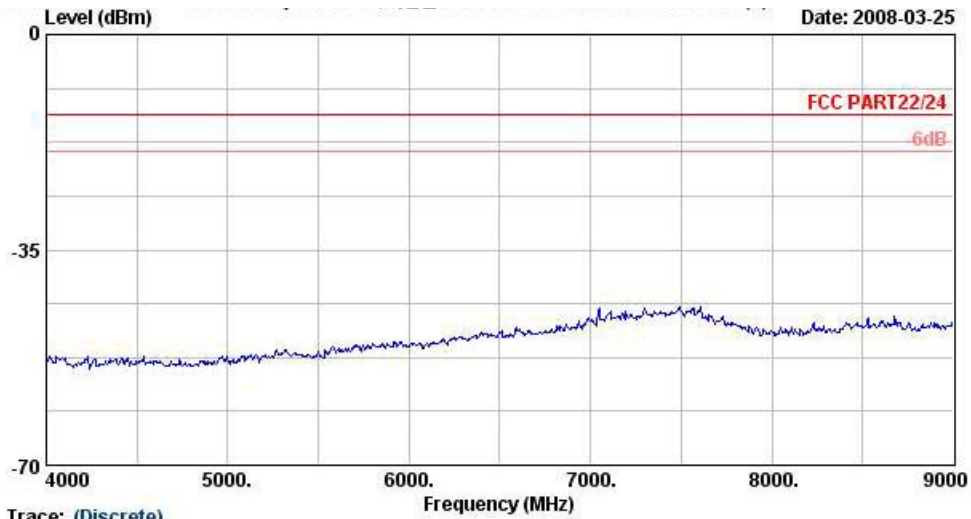

Trace: (Discrete)

Site : 03CH07-HY
Condition : FCC PART22/24 HF-EIRP(080306) VERTICAL
EUT : Tablet PC
Power : 120Vac/60Hz
Model : FG 812310-01
Mode : WCDMA Band V Link ; Ch4182 + Adaptor
Plane : 180 degree

Remark : Spurious emissions within 30-9000MHz were found more than 20dB below limit line. Because the spurious signal from the EUT was too low, the results above only showed the background noise to demonstrate compliant with the standard.



4.6.4.2 Mode 2

Horizontal Polarization

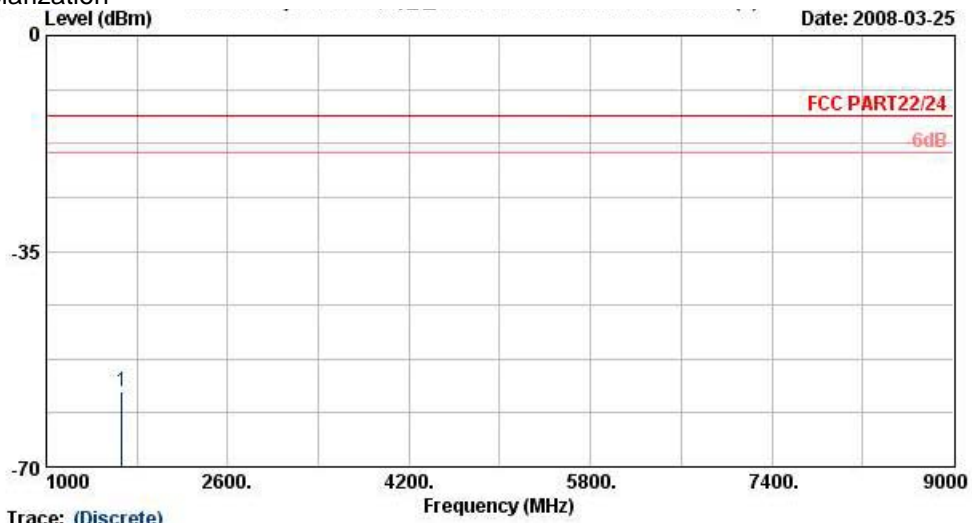

Trace: (Discrete)
 Site : 03CH07-HY
 Condition : FCC PART22/24 HF-EIRP(080306) HORIZONTAL
 EUT : Tablet PC
 Power : 120Vac/60Hz
 Model : FG 812310-01
 Mode : HSDPA Band V Link ; Ch4182 + Adaptor
 Plane : 180 degree

Frequency (MHz)	ERP (dBm)	Limit (dBm)	SPA Reading (dBm)	S.G. Power (dBm)	TX Cable loss (dB)	TX Antenna Gain (dBi)	Polarization (H/V)	Result
1669	-57.87	-13	-63.9	-56.8	3.39	4.55	H	Pass

Remark : Spurious emissions within 30-1000MHz were found more than 20dB below limit line.



Vertical Polarization

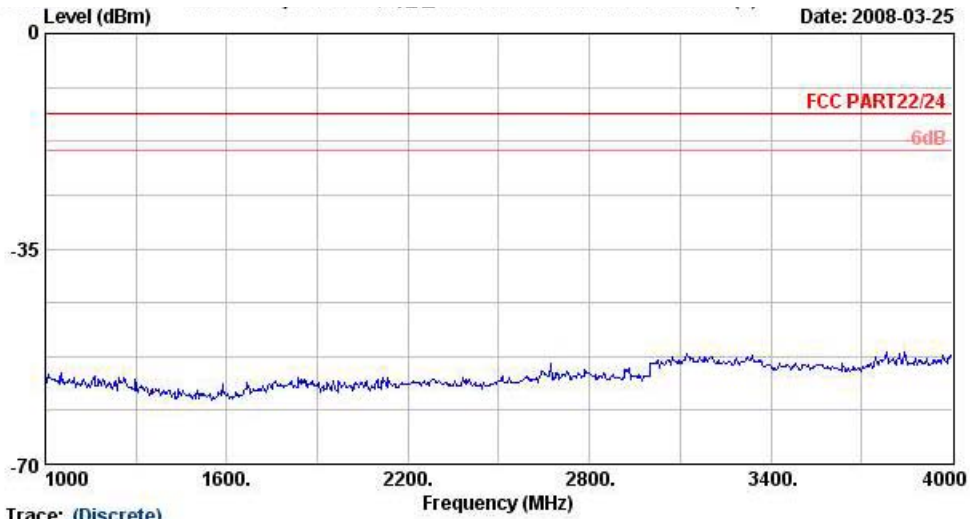

Trace: (Discrete)

Site : 03CH07-HY
Condition : FCC PART22/24 HF-EIRP(080306) VERTICAL
EUT : Tablet PC
Power : 120Vac/60Hz
Model : FG 812310-01
Mode : HSDPA Band V Link ; Ch4182 + Adaptor
Plane : 180 degree

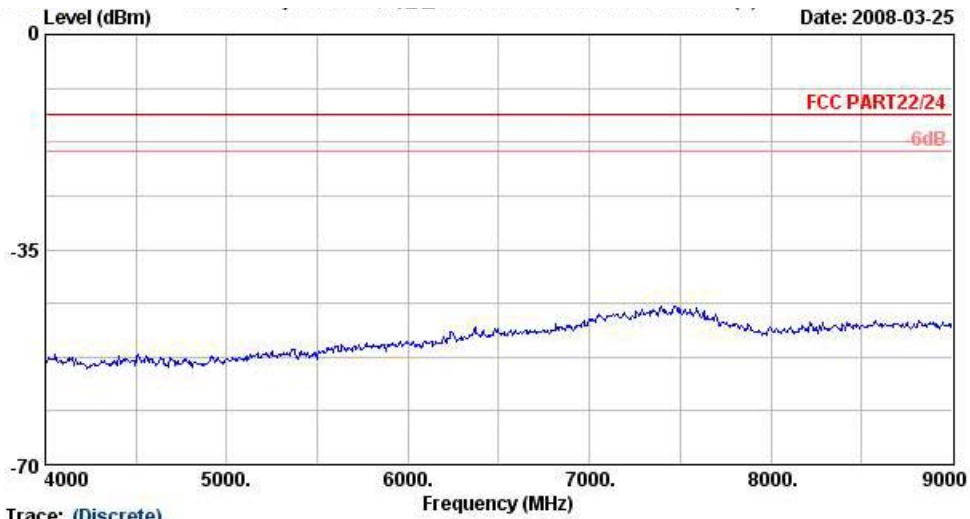

Trace: (Discrete)

Site : 03CH07-HY
Condition : FCC PART22/24 HF-EIRP(080306) VERTICAL
EUT : Tablet PC
Power : 120Vac/60Hz
Model : FG 812310-01
Mode : HSDPA Band V Link ; Ch4182 + Adaptor
Plane : 180 degree

Remark : Spurious emissions within 30-9000MHz were found more than 20dB below limit line. Because the spurious signal from the EUT was too low, the results above only showed the background noise to demonstrate compliant with the standard.



4.6.4.3 Mode 3

Horizontal Polarization

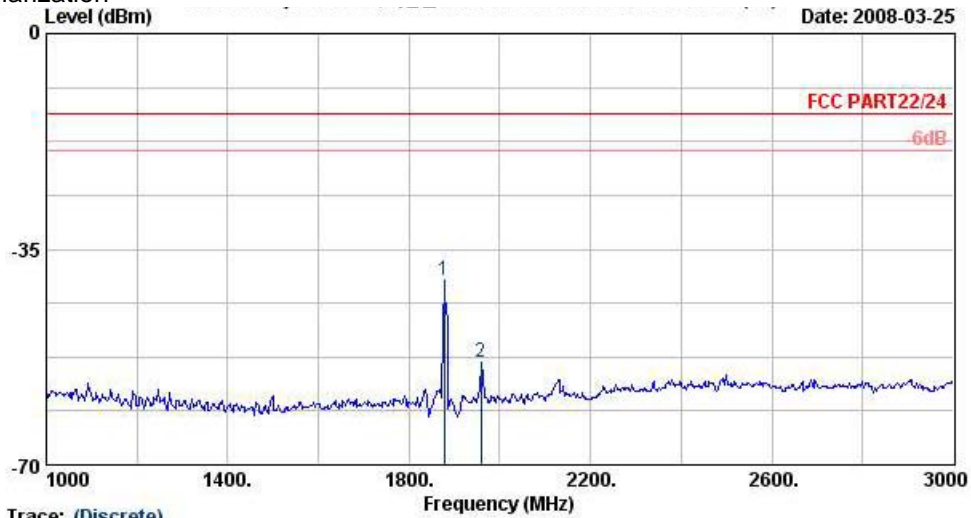

Trace: (Discrete)
 Site : 03CH07-HY
 Condition : FCC PART22/24 HF-EIRP(080306) HORIZONTAL
 EUT : Tablet PC
 Power : 120Vac/60Hz
 Model : FG 812310-01
 Mode : WCDMA Band II Link ; Ch9400 + Adaptor
 Plane : 180 degree

Remark : 1. #1 MS Signal.

2. #2 BS Signal.

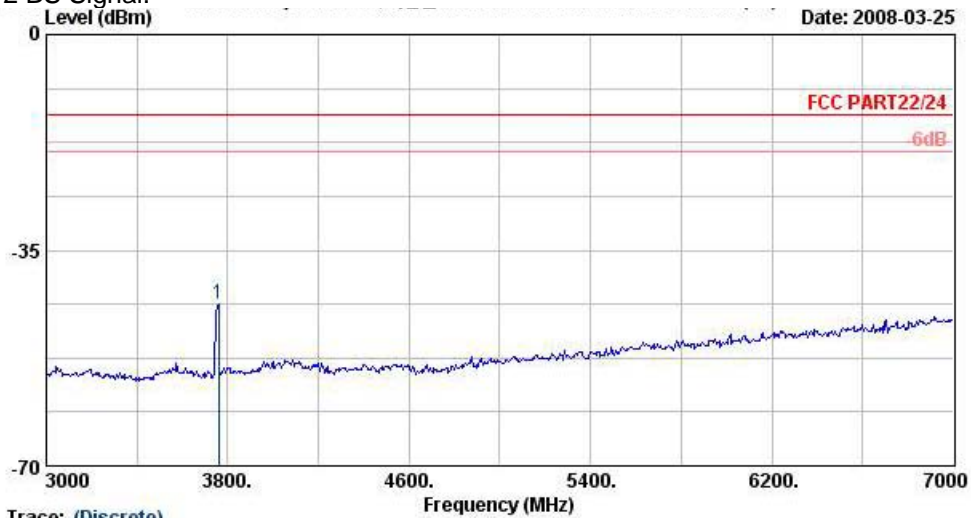

Trace: (Discrete)
 Site : 03CH07-HY
 Condition : FCC PART22/24 HF-EIRP(080306) HORIZONTAL
 EUT : Tablet PC
 Power : 120Vac/60Hz
 Model : FG 812310-01
 Mode : WCDMA Band II Link ; Ch9400 + Adaptor
 Plane : 180 degree

Frequency (MHz)	ERP (dBm)	Limit (dBm)	SPA Reading (dBm)	S.G. Power (dBm)	TX Cable loss (dB)	TX Antenna Gain (dBi)	Polarization (H/V)	Result
3760	-51.22	-13	-65.2	-55.1	4.03	7.91	V	Pass

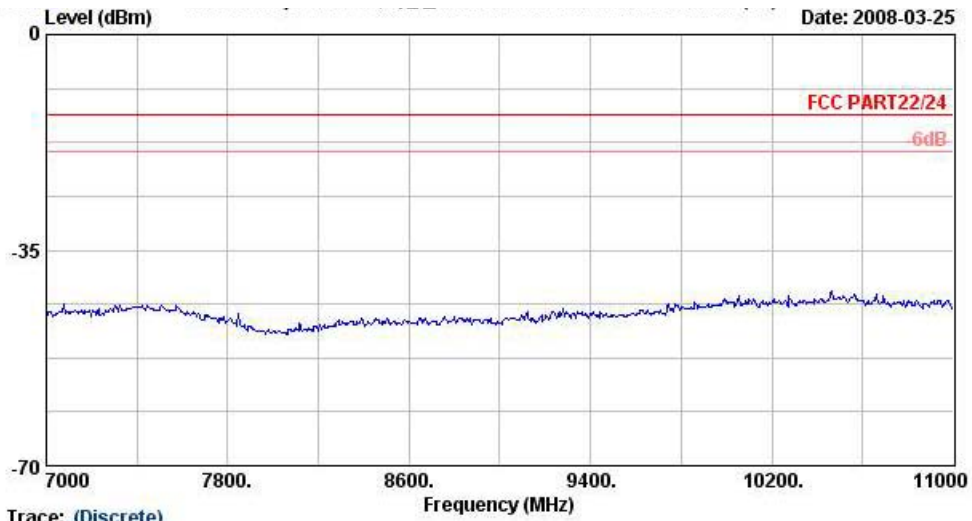

Trace: (Discrete)
Site : 03CH07-HY
Condition : FCC PART22/24 HF-EIRP(080306) HORIZONTAL
EUT : Tablet PC
Power : 120Vac/60Hz
Model : FG 812310-01
Mode : WCDMA Band II Link ; Ch9400 + Adaptor
Plane : 180 degree

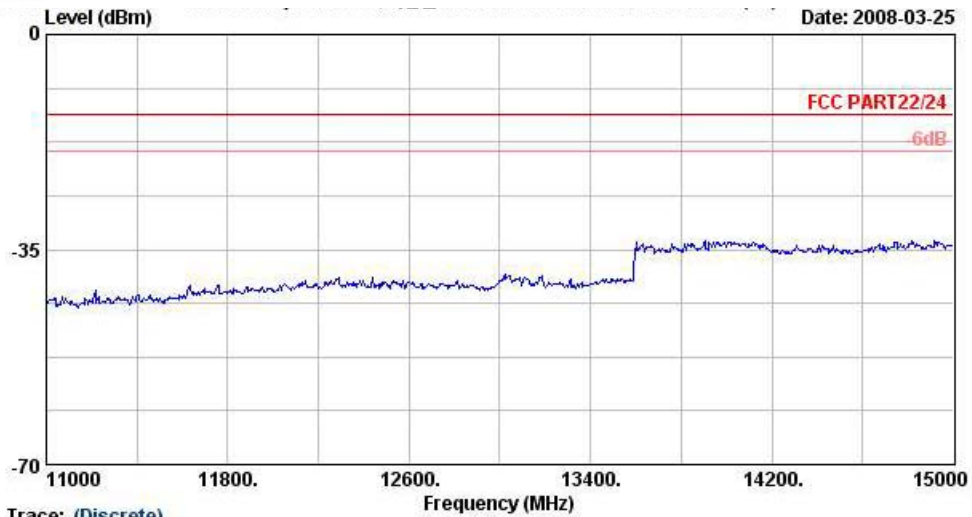

Trace: (Discrete)
Site : 03CH07-HY
Condition : FCC PART22/24 HF-EIRP(080306) HORIZONTAL
EUT : Tablet PC
Power : 120Vac/60Hz
Model : FG 812310-01
Mode : WCDMA Band II Link ; Ch9400 + Adaptor
Plane : 180 degree

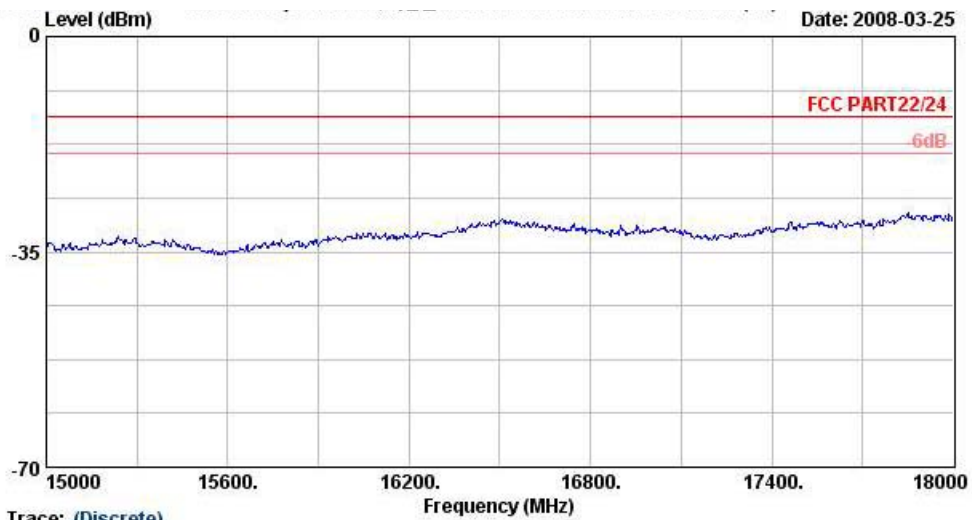

Trace: (Discrete)
Site : 03CH07-HY
Condition : FCC PART22/24 HF-EIRP(080306) HORIZONTAL
EUT : Tablet PC
Power : 120Vac/60Hz
Model : FG 812310-01
Mode : WCDMA Band II Link ; Ch9400 + Adaptor
Plane : 180 degree

Remark : Spurious emissions within 7000-18000MHz were found more than 20dB below limit line. Because the spurious signal from the EUT was too low, the results above only showed the background noise to demonstrate compliant with the standard.



Vertical Polarization

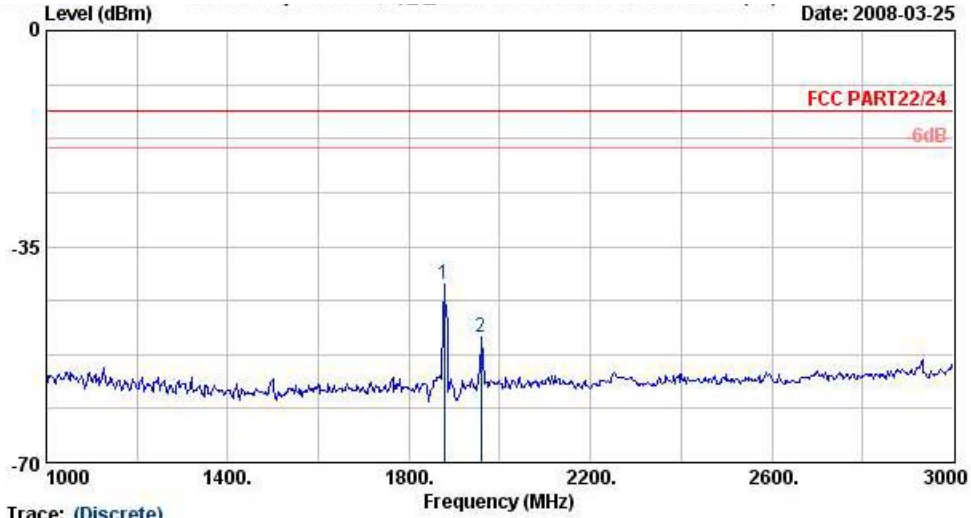

Trace: (Discrete)
 Site : 03CH07-HY
 Condition : FCC PART22/24 HF-EIRP(080306) VERTICAL
 EUT : Tablet PC
 Power : 120Vac/60Hz
 Model : FG 812310-01
 Mode : WCDMA Band II Link ; Ch9400 + Adaptor
 Plane : 180 degree

Remark : 1. #1 MS Signal.
 2. #2 BS Signal.

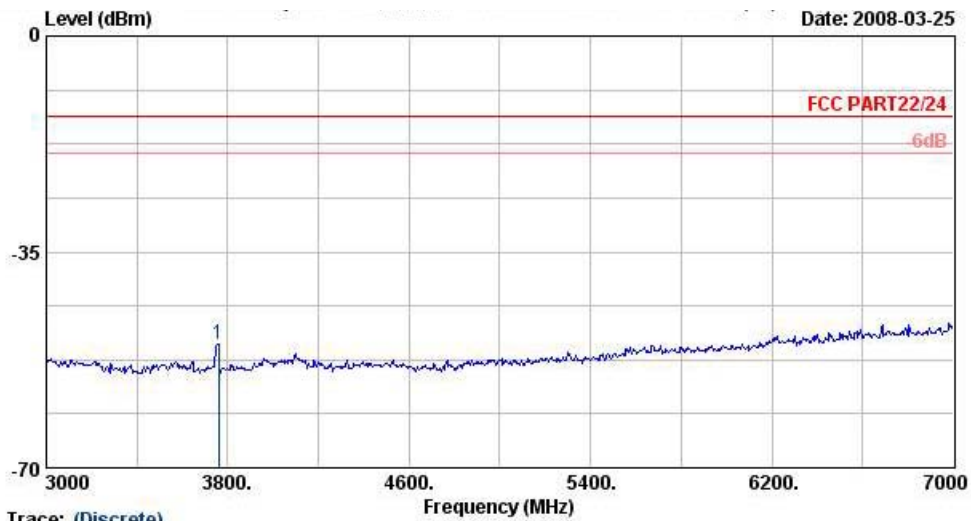

Trace: (Discrete)
 Site : 03CH07-HY
 Condition : FCC PART22/24 HF-EIRP(080306) VERTICAL
 EUT : Tablet PC
 Power : 120Vac/60Hz
 Model : FG 812310-01
 Mode : WCDMA Band II Link ; Ch9400 + Adaptor
 Plane : 180 degree

Frequency (MHz)	ERP (dBm)	Limit (dBm)	SPA Reading (dBm)	S.G. Power (dBm)	TX Cable loss (dB)	TX Antenna Gain (dBi)	Polarization (H/V)	Result
3760	-51.22	-13	-65.2	-55.1	4.03	7.91	V	Pass

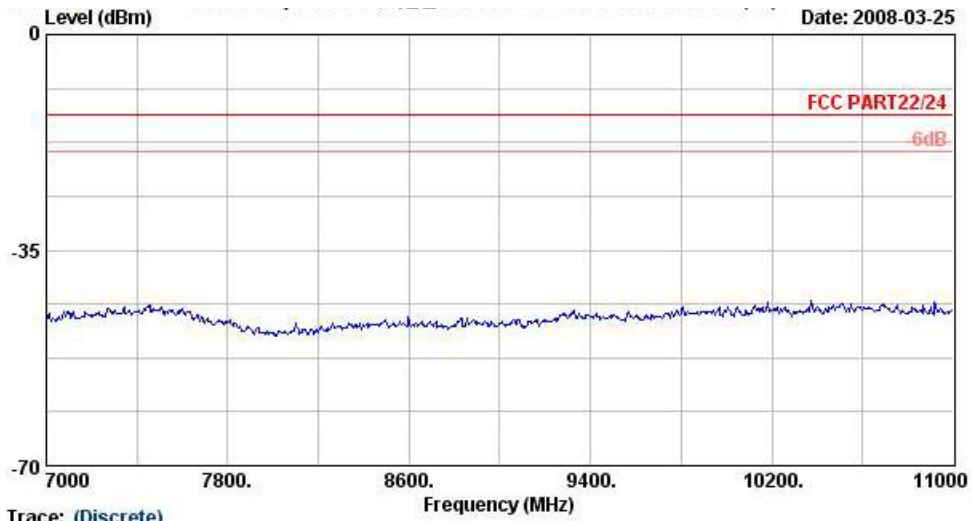

Trace: (Discrete)
Site : 03CH07-HY
Condition : FCC PART22/24 HF-EIRP(080306) VERTICAL
EUT : Tablet PC
Power : 120Vac/60Hz
Model : FG 812310-01
Mode : WCDMA Band II Link ; Ch9400 + Adaptor
Plane : 180 degree

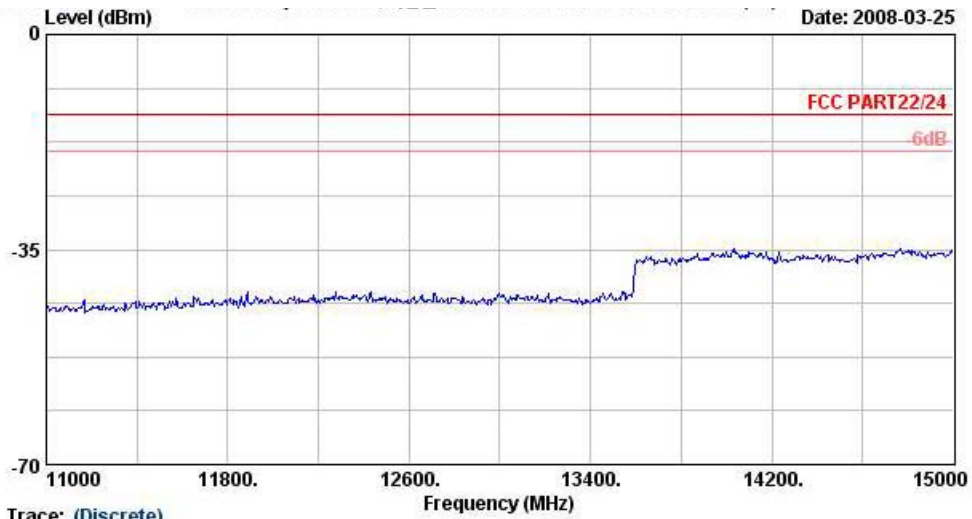

Trace: (Discrete)
Site : 03CH07-HY
Condition : FCC PART22/24 HF-EIRP(080306) VERTICAL
EUT : Tablet PC
Power : 120Vac/60Hz
Model : FG 812310-01
Mode : WCDMA Band II Link ; Ch9400 + Adaptor
Plane : 180 degree

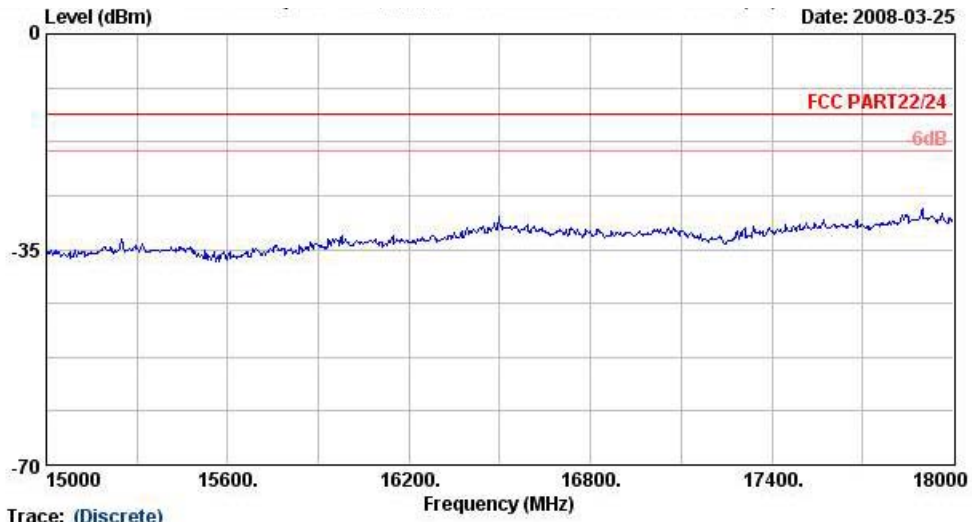

Site : 03CH07-HY
Condition : FCC PART22/24 HF-EIRP(080306) VERTICAL
EUT : Tablet PC
Power : 120Vac/60Hz
Model : FG 812310-01
Mode : WCDMA Band II Link ; Ch9400 + Adaptor
Plane : 180 degree

Remark : Spurious emissions within 7000-18000MHz were found more than 20dB below limit line. Because the spurious signal from the EUT was too low, the results above only showed the background noise to demonstrate compliant with the standard.



4.6.4.4 Mode 4

Horizontal Polarization

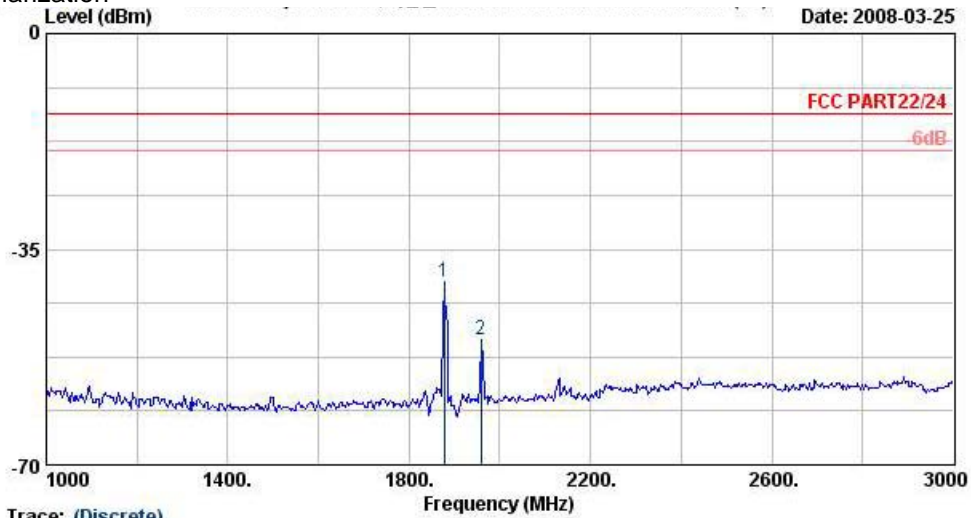

Trace: (Discrete)

Site : 03CH07-HY
 Condition : FCC PART22/24 HF-EIRP(080306) HORIZONTAL
 EUT : Tablet PC
 Power : 120Vac/60Hz
 Model : FG 812310-01
 Mode : HSDPA Band II Link ; Ch9400 + Adaptor
 Plane : 180 degree

Remark : 1. #1 MS Signal.

2. #2 BS Signal.

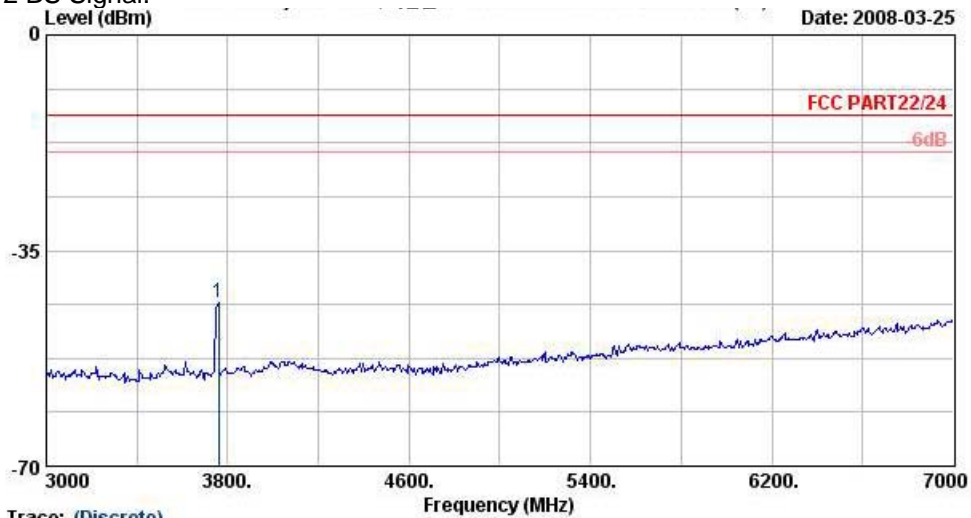

Trace: (Discrete)

Site : 03CH07-HY
 Condition : FCC PART22/24 HF-EIRP(080306) HORIZONTAL
 EUT : Tablet PC
 Power : 120Vac/60Hz
 Model : FG 812310-01
 Mode : HSDPA Band II Link ; Ch9400 + Adaptor
 Plane : 180 degree

Frequency (MHz)	ERP (dBm)	Limit (dBm)	SPA Reading (dBm)	S.G. Power (dBm)	TX Cable loss (dB)	TX Antenna Gain (dBi)	Polarization (H/V)	Result
3760	-43.92	-13	-57.75	-47.3	4.03	7.40	H	Pass

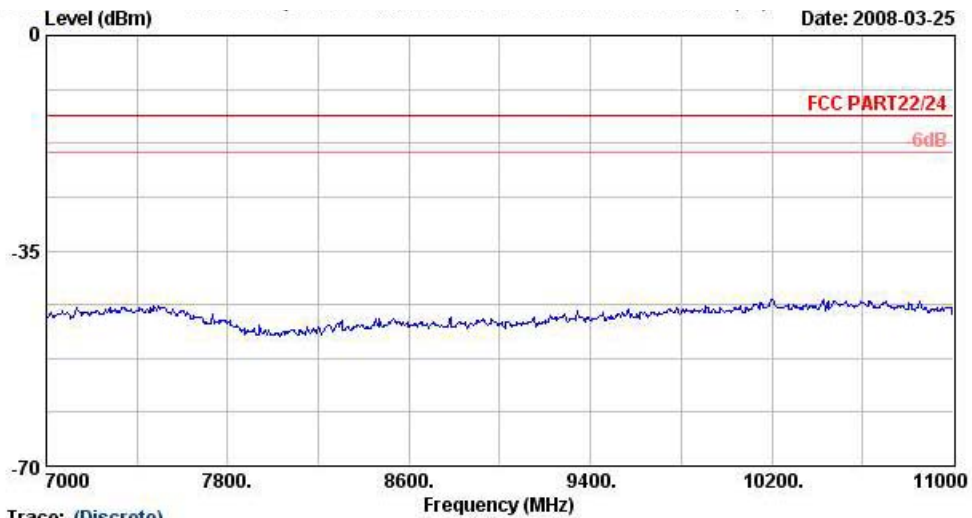

Date: 2008-03-25

Trace: (Discrete)

Site : 03CH07-HY
Condition : FCC PART22/24 HF-EIRP(080306) HORIZONTAL
EUT : Tablet PC
Power : 120Vac/60Hz
Model : FG 812310-01
Mode : HSDPA Band II Link ; Ch9400 + Adaptor
Plane : 180 degree

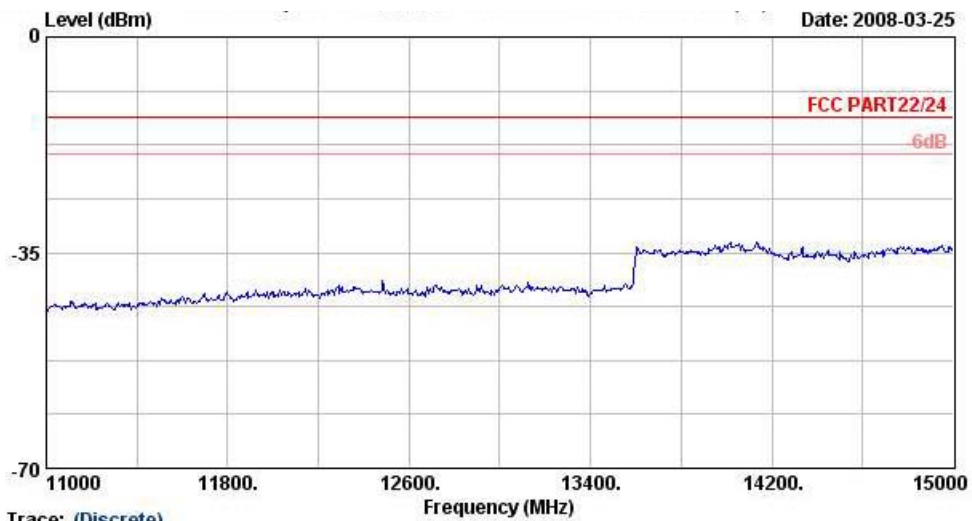

Date: 2008-03-25

Trace: (Discrete)

Site : 03CH07-HY
Condition : FCC PART22/24 HF-EIRP(080306) HORIZONTAL
EUT : Tablet PC
Power : 120Vac/60Hz
Model : FG 812310-01
Mode : HSDPA Band II Link ; Ch9400 + Adaptor
Plane : 180 degree

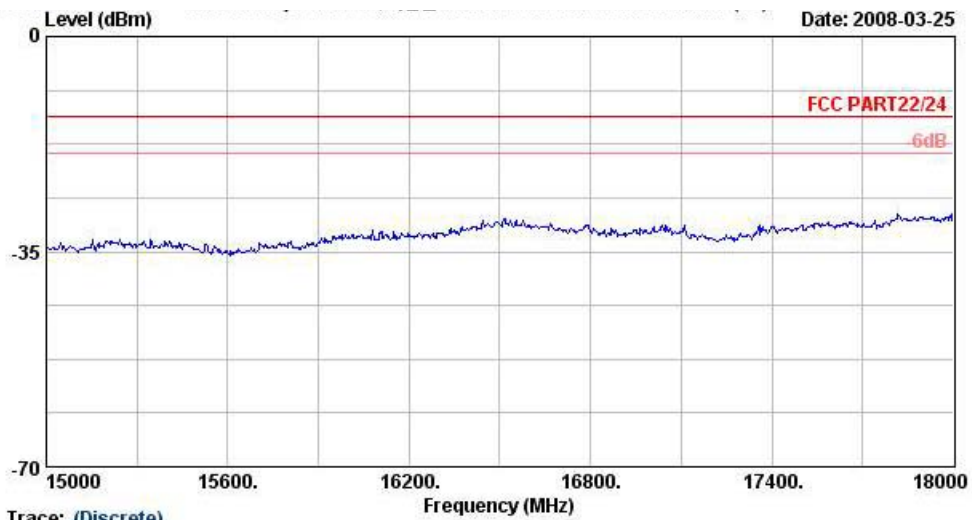

Trace: (Discrete)
Site : 03CH07-HY
Condition : FCC PART22/24 HF-EIRP(080306) HORIZONTAL
EUT : Tablet PC
Power : 120Wac/60Hz
Model : FG 812310-01
Mode : HSDPA Band II Link ; Ch9400 + Adaptor
Plane : 180 degree

Remark : Spurious emissions within 7000-18000MHz were found more than 20dB below limit line.
Because the spurious signal from the EUT was too low, the results above only showed the background noise to demonstrate compliant with the standard.



Vertical Polarization

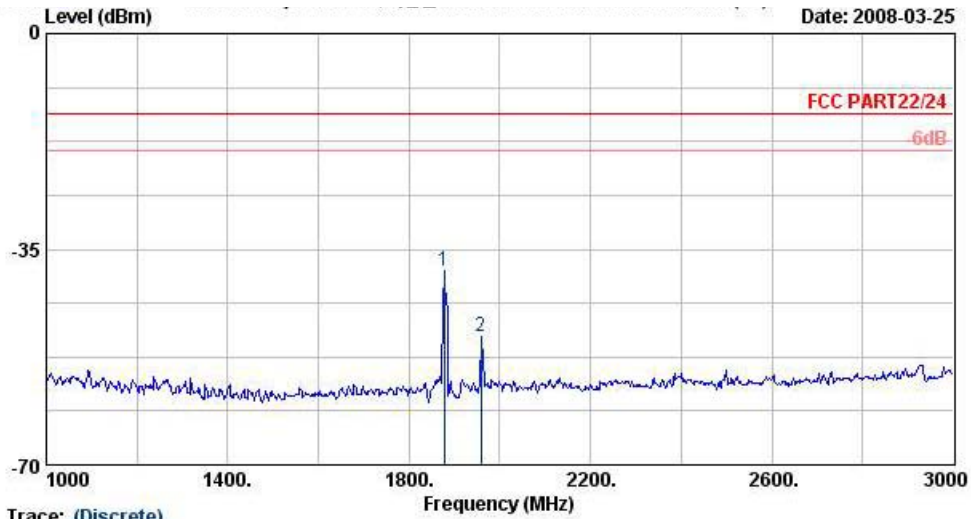

Trace: (Discrete)
 Site : 03CH07-HY
 Condition : FCC PART22/24 HF-EIRP(080306) VERTICAL
 EUT : Tablet PC
 Power : 120Vac/60Hz
 Model : FG 812310-01
 Mode : HSDPA Band II Link ; Ch9400 + Adaptor
 Plane : 180 degree

Remark : 1. #1 MS Signal.
 2. #2 BS Signal.

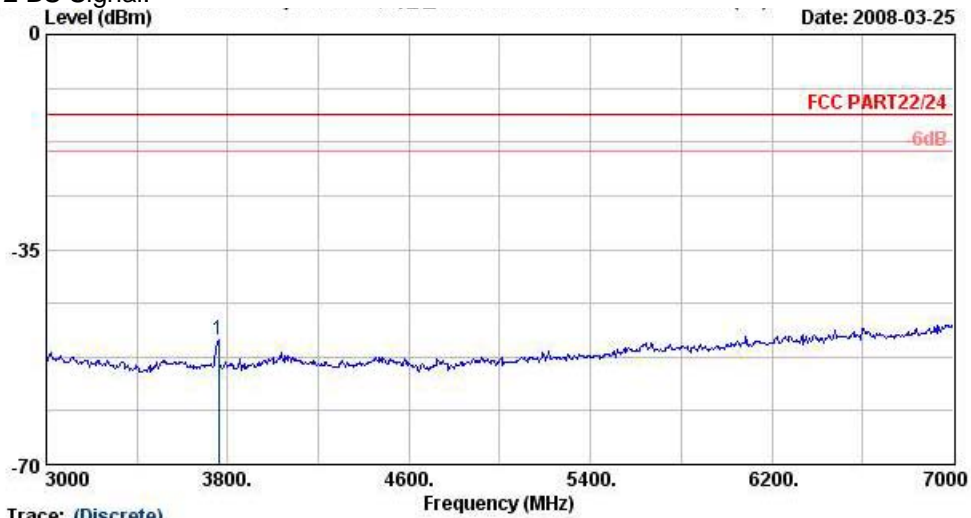

Trace: (Discrete)
 Site : 03CH07-HY
 Condition : FCC PART22/24 HF-EIRP(080306) VERTICAL
 EUT : Tablet PC
 Power : 120Vac/60Hz
 Model : FG 812310-01
 Mode : HSDPA Band II Link ; Ch9400 + Adaptor
 Plane : 180 degree

Frequency (MHz)	ERP (dBm)	Limit (dBm)	SPA Reading (dBm)	S.G. Power (dBm)	TX Cable loss (dB)	TX Antenna Gain (dBi)	Polarization (H/V)	Result
3760	-50.72	-13	-64.93	-54.6	4.03	7.91	V	Pass

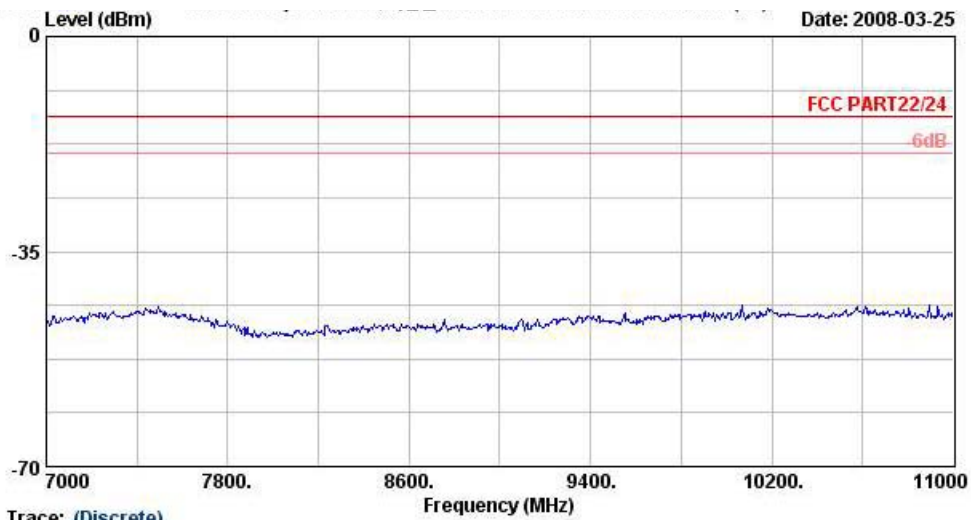

Trace: (Discrete)

Site : 03CH07-HY
Condition : FCC PART22/24 HF-EIRP(080306) VERTICAL
EUT : Tablet PC
Power : 120Vac/60Hz
Model : FG 812310-01
Mode : HSDPA Band II Link , Ch9400 + Adaptor
Plane : 180 degree

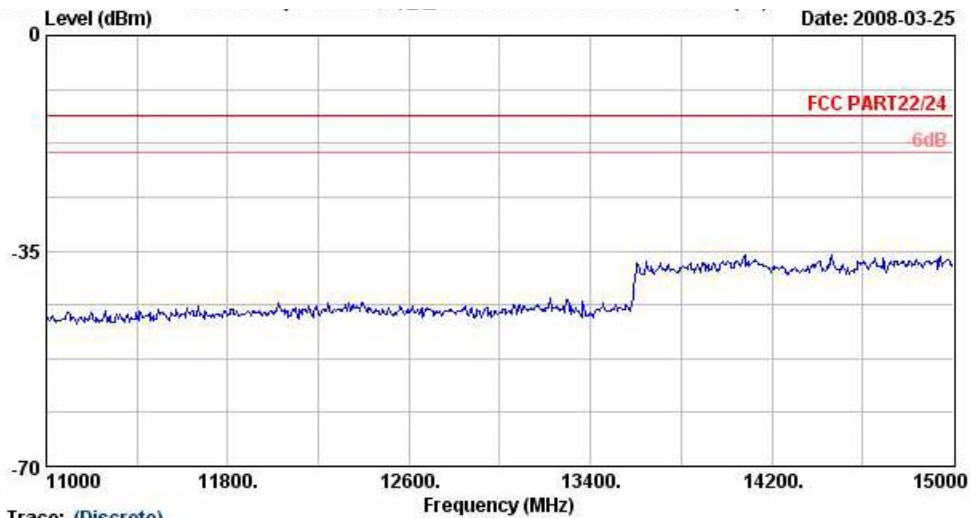

Trace: (Discrete)

Site : 03CH07-HY
Condition : FCC PART22/24 HF-EIRP(080306) VERTICAL
EUT : Tablet PC
Power : 120Vac/60Hz
Model : FG 812310-01
Mode : HSDPA Band II Link ; Ch9400 + Adaptor
Plane : 180 degree

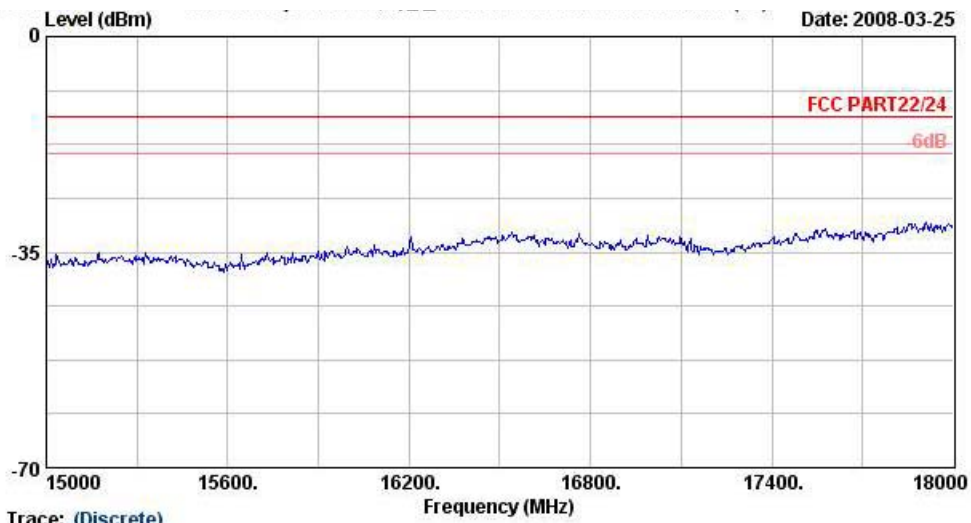

Trace: (Discrete)
Site : 03CH07-HY
Condition : FCC PART22/24 HF-EIRP(080306) VERTICAL
EUT : Tablet PC
Power : 120Vac/60Hz
Model : FG 812310-01
Mode : HSDPA Band II Link ; Ch9400 + Adaptor
Plane : 180 degree

Remark : Spurious emissions within 7000-18000MHz were found more than 20dB below limit line.
Because the spurious signal from the EUT was too low, the results above only showed the background noise to demonstrate compliant with the standard.

4.7 Frequency Stability (Temperature Variation)

4.7.1 Measurement Instrument

As described in chapter 5 of this test report.

4.7.2 Test Procedure

- a. The EUT and test equipment were set up as shown on the following section.
- b. With all power removed, the temperature was decreased to -30°C and permitted to stabilize for three hours. Power was applied and the maximum change in frequency was noted within one minute.
- c. With power OFF, the temperature was raised in 10°C steps. The sample was permitted to stabilize at each step for at least one-half hour. Power was applied and the maximum frequency change was noted within one minute.
- d. The temperature tests were performed for the worst case.
- e. Test data was recorded.

4.7.3 Test Setup Layout

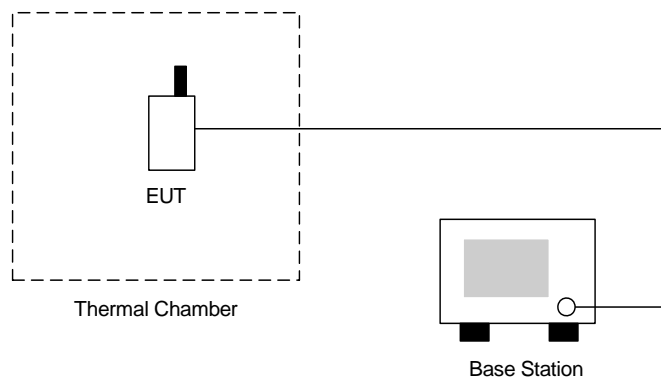



4.7.4 Test Result

• Test Mode : WCDMA Band V CH4182

Temperature(°C)	Change (Hz)	Change (ppm)	Limit (ppm)	Result
-30	-14	-0.02	2.5	Passed
-20	28	0.03		
-10	-25	-0.03		
0	-17	-0.02		
10	28	0.03		
20	39	0.05		
30	-56	-0.07		
40	-40	-0.05		
50	18	0.02		

• Test Mode : WCDMA Band V (HSDPA) CH4182

Temperature(°C)	Change (Hz)	Change (ppm)	Limit (ppm)	Result
-30	10	0.01	2.5	Passed
-20	24	0.03		
-10	-33	-0.04		
0	-18	-0.02		
10	24	0.03		
20	-30	-0.04		
30	22	0.03		
40	46	0.05		
50	-27	-0.03		



• Test Mode : WCDMA Band II CH9400

Temperature(°C)	Change (Hz)	Change (ppm)	Limit (ppm)	Result
-30	-28	-0.01	2.5	Passed
-20	36	0.02		
-10	31	0.02		
0	38	0.02		
10	26	0.01		
20	-34	-0.02		
30	-38	-0.02		
40	29	0.02		
50	-25	-0.01		

• Test Mode : WCDMA Band II (HSDPA) CH9400

Temperature(°C)	Change (Hz)	Change (ppm)	Limit (ppm)	Result
-30	-22	-0.01	2.5	Passed
-20	-24	-0.01		
-10	36	0.02		
0	-30	-0.02		
10	-38	-0.02		
20	-34	-0.02		
30	45	0.02		
40	40	0.02		
50	-34	-0.02		

4.8 Frequency Stability (Voltage Variation)

4.8.1 Measurement Instrument

As described in chapter 5 of this test report.

4.8.2 Test Procedure

- a. The EUT was placed in a temperature chamber at $25\pm 5^{\circ}\text{C}$ and connected as the following section.
- b. The power supply voltage to the EUT was varied from BEP to 115% of the nominal value measured at the input to the EUT.
- c. The variation in frequency was measured for the worst case.

4.8.3 Test Setup Layout

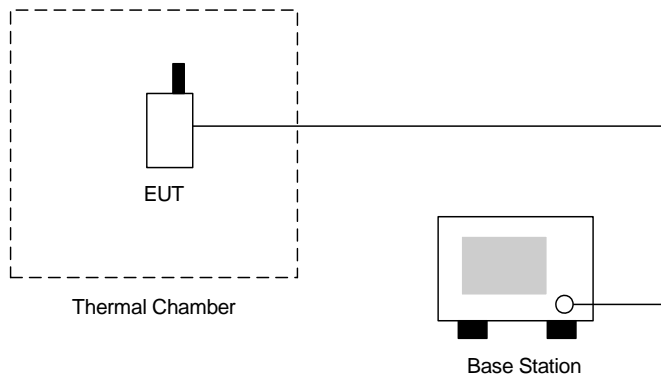

4.8.4 Test Result

- Test Mode : WCDMA Band V CH4182

Voltage(Volt)	Change (Hz)	Change (ppm)	Limit (ppm)	Result
230	-19	-0.02	2.5	Passed
BEP	-27	-0.03		
253	-11	-0.01		

- Test Mode : WCDMA Band V (HSDPA) CH4182

Voltage(Volt)	Change (Hz)	Change (ppm)	Limit (ppm)	Result
230	-26	-0.03	2.5	Passed
BEP	20	0.02		
253	13	0.02		



- Test Mode : WCDMA Band II CH9400

Voltage(Volt)	Change (Hz)	Change (ppm)	Limit (ppm)	Result
230	30	0.02	2.5	Passed
BEP	-25	-0.01		
253	-36	-0.02		

- Test Mode : WCDMA Band II (HSDPA) CH9400

Voltage(Volt)	Change (Hz)	Change (ppm)	Limit (ppm)	Result
230	-34	-0.02	2.5	Passed
BEP	-27	-0.01		
253	10	0.05		

Remark:

1. Normal Voltage= 230V.
2. Battery End Point (BEP)= 207 V.



5. List of Measurement Equipments

Instrument	Manufacturer	Model No.	Serial No.	Characteristics	Calibration Date	Due Date	Remark
Spectrum Analyzer	Agilent	E4408B	MY44211028	9KHz-26.5GHz	Oct. 17, 2007	Oct. 16, 2008	Radiation (03CH07-HY)
EMI Test Receiver	R&S	ESCS30	100356	9KHz-2.75GHz	Jul. 26, 2007	Jul. 25, 2008	Radiation (03CH07-HY)
Bilog Antenna	SCHAFFNER	CBL6112B	2885	30MHz -2GHz	Dec. 01, 2007	Nov. 30, 2008	Radiation (03CH07-HY)
Double Ridge Horn Antenna	Com-Power	AH118	071025	1G~18G	Jun. 04, 2007	Jun. 03, 2008	Radiation (03CH07-HY)
SHF-EHF Horn	SCHWARZBECK	BBHA 9170	9170-251	14G - 40G	Oct. 17, 2007	Oct. 16, 2008	Radiation (03CH07-HY)
Pre Amplifier	Agilent	8449B	3008A01917	1G - 26.5G	Nov. 22, 2007	Nov. 21, 2008	Radiation (03CH07-HY)
Pre Amplifier	EMEC	PA303	PA303-SMA-059	100K~3GHz	Nov. 26, 2007	Nov. 25, 2008	Radiation (03CH07-HY)
Base Station Simulator	R & S	CMU200	103937	Third-Band	Oct. 19, 2007	Oct. 18, 2008	Radiation (03CH07-HY)
Thermal Chamber	Tenyi technology	TTH-D35P	TBN-930701	N/A	Aug. 02, 2007	Aug. 01, 2008	Conduction (TH02-HY)
Spectrum	R&S	FSP40	100055	9KHz~40GHz	Jun. 25, 2007	Jun. 24, 2008	Conduction (TH02-HY)
Bluetooth Test	ANRITSU	MT8852A	6K00003939	N/A	N/A	N/A	Conduction (TH02-HY)
Power Divider	ARRA	5200-1	3871	N/A	Oct. 01, 2007	Sep. 30, 2008	Conduction (TH02-HY)
DC Power Supply	TOPWARD	3303D	740889	N/A	May 25, 2007	May 24, 2009	Conduction (TH02-HY)
Power Meter	Agilent	E4416A	GB41292344	N/A	Feb. 21, 2008	Feb. 20, 2009	Conduction (TH02-HY)
Power Sensor	Agilent	E9327A	US40441548	N/A	Feb. 21, 2008	Feb. 20, 2009	Conduction (TH02-HY)

6. Uncertainty Evaluation

Uncertainty of Radiated Emission Measurement (30MHz ~ 1000MHz)

Contribution	Uncertainty of x_i		$u(x_i)$
	dB	Probability Distribution	
Receiver reading	0.41	Normal(k=2)	0.21
Antenna factor calibration	0.83	Normal(k=2)	0.42
Cable loss calibration	0.25	Normal(k=2)	0.13
Pre Amplifier Gain calibration	0.27	Normal(k=2)	0.14
RCV/SPA specification	2.50	Rectangular	0.72
Antenna Factor Interpolation for Frequency	1.00	Rectangular	0.29
Site imperfection	1.43	Rectangular	0.83
Mismatch	+0.39/-0.41	U-shaped	0.28
Combined standard uncertainty Uc(y)	1.27		
Measuring uncertainty for a level of Confidence of 95% U=2Uc(y)	2.54		

Uncertainty of Radiated Emission Measurement (1GHz ~ 40GHz)

Contribution	Uncertainty of x_i		$u(x_i)$	C_i	$C_i * u(x_i)$
	dB	Probability Distribution			
Receiver reading	±0.10	Normal(k=1)	0.10	1	0.10
Antenna factor calibration	±1.70	Normal(k=2)	0.85	1	0.85
Cable loss calibration	±0.50	Normal(k=2)	0.25	1	0.25
Receiver Correction	±2.00	Rectangular	1.15	1	1.15
Antenna Factor Directional	±1.50	Rectangular	0.87	1	0.87
Site imperfection	±2.80	Triangular	1.14	1	1.14
Mismatch Receiver VSWR $\Gamma_1 = 0.197$ Antenna VSWR $\Gamma_2 = 0.194$ Uncertainty = $20 \log(1 - \Gamma_1 * \Gamma_2 * \Gamma_3)$	+0.34/-0.35	U-shaped	0.244	1	0.244
Combined standard uncertainty Uc(y)	2.36				
Measuring uncertainty for a level of Confidence of 95% U=2Uc(y)	4.72				

END OF TEST REPORT