

TEST REPORT

of

FCC Part 15 Subpart B & C

<Tested with Bluetooth>

Product : **Notebook Personal Computer**

Model(s): **V100**

(with SIERRA EVDO Module, Model:MC5725V)

(with WLAN a/b/g Module, INTEL, Model:WM3945ABG)

(with Bluetooth Module, BILLIONTON, Model:GUBTCR42M)

Brand: GETAC

Applicant: **MITAC Technology Corporation**

Address: **4F, No.1, R&D Road 2,
Hsinchu Science-Based industrial Park,
Hsinchu 300
Taiwan**

Test Performed by:

International Standards Laboratory

<Lung-Tan LAB>

*Site Registration No.

BSMI: SL2-IN-E-0013; TAF: 0997

IC: IC4164-1; VCCI: R-1435, C-1440, T-299; NEMKO: ELA 113B

*Address:

No. 120, Lane 180, San Ho Tsuen, Hsin Ho Rd.

Lung-Tan Hsiang, Tao Yuan County 325, Taiwan

*Tel : 886-3-407-1718; Fax: 886-3-407-1738

Report No.: **ISL-07LR033FCBT**

Issue Date : **2008/01/30**

Contents of Report

1.	General	1
1.1	Certification of Accuracy of Test Data	1
1.2	Applicant & Manufacturer Information	2
1.3	Test Results Summary	3
2.	Description of Equipment Under Test (EUT)	4
3.	Description of Support Equipment.....	8
3.1	Description of Support Equipment	8
3.1.1	Software for Controlling Support Unit	8
3.1.2	I/O Cable Condition of EUT and Support Units.....	9
4.	TEST RESULTS (Bluetooth).....	10
4.1	Powerline Conducted Emissions	10
4.1.1	EUT Configuration	10
4.1.2	Test Procedure	10
4.1.3	EMI Receiver/Spectrum Analyzer Configuration (for the frequencies tested).....	10
4.1.4	Test Data:.....	11
4.2	FHSS Maximum Peak Output Power	13
4.2.1	Test Procedure	13
4.2.2	Test Setup	13
4.2.3	Test Data	14
4.3	Radiated Emission Measurement	20
4.3.1	EUT Configuration	20
4.3.2	Test Procedure	20
4.3.3	EMI Receiver/Spectrum Analyzer Configuration (for the frequencies tested).....	20
4.3.4	Test Data (30MHz – 1GHz): With Data Rate= 1MBps, DH5	21
4.3.5	Test Data (1GHz – 25 GHz): With Data Rate= 1MBps, DH5.....	22
4.4	Band Edge Measurement.....	25
4.4.1	Test Procedure	25
4.4.2	Test Setup	25
4.4.3	Test Data:.....	26
4.5.1	Test Procedure (Radiated)	35
4.5.2	Test Setup (Radiated)	35
4.5.3	Test Data.....	36
4.6	Bandwidth & Hopping Channel Separation.....	45
4.6.1	Standard Applicable.....	45
4.6.2	Test Procedure	45
4.6.3	Test Setup	45
4.6.4	Test Data.....	46
4.7	Number of Hopping Frequency Used.....	54
4.7.1	Test Procedure	54
4.7.2	Test Setup	54
4.7.3	Test Data.....	54
4.8	Dwell Time	56
4.8.1	Test Procedure	56
4.8.2	Test Setup	56
4.8.3	Test Data.....	57

5.	Appendix	75
5.1	Appendix A: Measurement Procedure for Power line Conducted Emissions.....	75
5.2	Appendix B: Test Procedure for Radiated Emissions	76
5.3	Appendix C: Test Equipment	77
5.3.1	Test Equipment List.....	77
5.3.2	Software for Controlling Spectrum/Receiver and Calculating Test Data.....	77
5.4	Appendix D: Layout of EUT and Support Equipment.....	78
5.4.1	General Conducted Test Configuration	78
5.4.2	General Radiation Test Configuration.....	79
5.5	Appendix E: Accuracy of Measurement	80
5.6	Appendix F: Photographs of EUT Configuration Test Set Up.....	81
5.7	Appendix G: Antenna Specification.....	84

1. General

1.1 Certification of Accuracy of Test Data

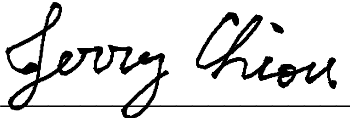
Standards:	CFR 47 Part 15 Subpart B Class B CFR 47 Part 15 Subpart C (Section 15.247)
Test Procedure:	ANSI C63.4:2003
Equipment Tested:	Notebook Personal Computer
Model:	V100
Applied by:	MITAC Technology Corporation
Sample received Date:	2007/10/26
Final Test Date :	2008/01/30
Test Result	PASS
Test Site:	Chamber 12, Conduction 02
Temperature	Refer to each site test data
Humidity:	Refer to each site test data
Test Engineer:	 Jerry Chiou

All the tests in this report have been performed and recorded in accordance with the standards described above and performed by an independent electromagnetic compatibility consultant, International Standards Laboratory.

The test results contained in this report accurately represent the measurements of the characteristics and the energy generated by sample equipment under test at the time of the test. The sample equipment tested as described in this report is in compliance with the limits of above standards.

Approve & Signature

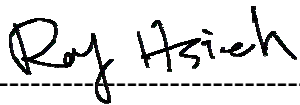

Roy Hsieh / Manager

Test results given in this report apply only to the specific sample(s) tested under stated test conditions. This report shall not be reproduced other than in full without the explicit written consent of ISL. This report totally contains 87 pages, including 1 cover page, 2 contents page, and 84 pages for the test description.

This test data shown below is traceable to NIST or national or international standard. International Standards Laboratory certifies that no party to this application has been denied the FCC benefits pursuant to Section 5301 of the Anti-Drug Abuse Act of 1988, 21 U.S.C. 853(a).

1.2 Applicant & Manufacturer Information

Applicant: Mitac Technology Corp
No. 1, R&D 2nd RD., Hsin-Chu Science Based Industrial Park
Hsin-Chu Hsien,
Taiwan

Manufacturer 1: Mitac Technology Corp
No. 1, R&D 2nd RD., Hsin-Chu Science Based Industrial Park
Hsin-Chu Hsien,
Taiwan

Manufacturer 2: Getac Technology (Kunshan) Co., Ltd
No. 269, 2nd Road, Export Processing Zone,
Changjiang South, Road,
Kunshan, Jiangsu, P.R.C Zip code: 215300

1.3 Test Results Summary

The Bluetooth functions of EUT has been tested according to the FCC regulations listed below:

Tested Standards: 47 CFR Part 15 Subpart C			
Standard Section	Test Type	Result	Remarks
15.207(a)	AC Power Line Emissions	Pass	
15.247(b) (1)	Max. Peak Output Power	Pass	
15.209(a)	Radiated Emissions 30MHz – 25 GHz	Pass	
15.247 (c)	Band Edge Measurement	Pass	
15.247(a)(1)(iii)	Number of Hopping Frequency Used	Pass	
15.247(a) (1)(ii)	Spectrum Bandwidth Of FHSS device	Pass	
15.247(a)(1)	Hopping Channel Separation	Pass	
15.247(a)(1)(iii)	Dwell Time	Pass	

2. Description of Equipment Under Test (EUT)

Description:	Notebook Personal Computer
Condition:	Pre-Production
Model:	V100
Brand:	GETAC
Wireless LAN Module:	Intel, Model: WM3945ABG
Bluetooth Module:	BILLIONTON (Model:GUBTCR42M)
Frequency Range of 802.11a:	5150 - 5250 MHz 5250 - 5350 MHz 5725 - 5850 MHz
Frequency Range of 802.11b/g:	2400 - 2483.5 MHz
Frequency Range of Bluetooth:	2400 - 2483.5 MHz
Support channel:	
802.11a Normal mode	13 Channels
802.11b/g	11 Channels
Bluetooth	79 Channels
Modulation Skill:	
802.11a	OFDM (6 Mbps – 54 Mbps)
802.11b	DBPSK(1Mbps), DQPSK(2Mbps), CCK(5.5/11Mbps)
802.11g	OFDM (6M - 54Mbps)
Bluetooth	GFSK (1Mbps) DQPSK(2Mbps), 8DPSK(3Mbps)
Antennas Type:	
WLAN Right antenna:	PIFA (P/N: IA-060076) White made by JOINSOON ELECTRONICS MFG. CO., LTD
WLAN Left antenna:	PIFA (P/N: IA-060239) Black made by JOINSOON ELECTRONICS MFG. CO., LTD
Bluetooth antenna:	PIFA Antenna(P/N: IA060093), made by JOINSOON ELECTRONICS MFG. CO.,LTD.
Antenna Connected:	Connected to RF connector on the PCB of the Bluetooth or WLAN module .The user is not possible to change the antenna without disassembling the notebook computer.
Antenna peak Gain:	
WLAN Right antenna	1.61dBi(11b,11g), 2.45dBi(11a)
WLAN Left antenna	-0.55 dBi (11b,11g), 3.97 dBi (11a)
Bluetooth antenna	-0.8 dBi
Power Type of wireless module:	3.3V DC from Notebook PC
Power Type of Bluetooth module:	3.3V DC from Notebook PC

The channel and the operation frequency of 802.11a listed below:

Channel	Frequency(MHz)	Channel	Frequency(MHz)
01	5180	02	5200
03	5220	04	5240
05	5260	06	5280
07	5300	08	5320
09	5745	10	5765
11	5785	12	5805
13	5825		

The channel and the operation frequency of 802.11b and 802.11g listed below:

Channel	Frequency(MHz)	Channel	Frequency(MHz)
01	2412	07	2442
02	2417	08	2447
03	2422	09	2452
04	2427	10	2457
05	2432	11	2462
06	2437		

The channels and the operation frequency of Bluetooth listed below:

Channel	Frequency(MHz)	Channel	Frequency(MHz)
00	2402	01	2403
02	2404	03	2405
04	2406	05	2407
.....			
75	2477	76	2478
77	2479	78	2480

WWAN HW version	SIERRA,Model:MC5725V, REV2.0
WWAN TX Frequency	CDMA2000 Cellular : 824MHz~849MHz CDMA2000 PCS : 1850MHz ~ 1910MHz
WWAN Rx Frequency	CDMA2000 Cellular : 869MHz~894MHz CDMA2000 PCS : 1930MHz ~ 1990MHz
WWAN Antenna Type	PIFA Antenna
WWAN Antenna Gain	0.52dBi (850MHz), 2.06dBi(1900MHz)
WWAN Type of Antenna Connector	I-PEX

CPU:	Genuine intel U2500 1.2GHz
Adapter Type:	Auto Switching AC Adapter 100-240V,1.2A 50-60Hz EPS (Model: F10903-A)
Hard Disk Driver:	Toshiba (Model:MK8032GSX) 80G or Toshiba (Model:MK1234GSX) 120G
Modem Card:	Conexant (Model: RD-02-D330)
Wireless LAN Card:	Intel(Model:WM3945ABG)
Bluetooth module:	BILLIONTON(Model:GUBTCR42M)
USB Connector:	two 4 pin
RJ11 Connector:	one 2 pin
Serial Port:	two 9 pin
RJ45 Connector:	one 8 pin
Line out Port:	one
Line-in Port:	one
SD Card Port:	one
PCMCIA Slot:	two
DC IN Port:	one
Battery:	MITAC(Model: BP-LC2600/33-0151), 11.1Vdc, 7800mAh
LCD:	Toshiba(Model: LTD104KA1S) or Toshiba(Model: LTD121EXEV)
DDR:	Infineon(Model:PC2-4200S-444-11-A0) 512M Hnnix(Model:PC2-5300S555-12) 1G
Power Cord:	Non-shielded, Detachable

Test configuration:

configuration	LCD	CPU	Adapter Type	Hard Disk	Modem Card	Wireless LAN Card	Battery	DDR
1	Toshiba(Model: LTD104 KA1S)	Genuine intel U2500 1.2GHz	EPS (Model: F10903-A)	Toshiba (Model:MK1234GSX) 120G	Conexant (Model: RD-02-D330)	Intel(Model :WM3945 ABG)	MITAC(M odel:BP-L C2600/33-0 151)	Hnnix(M odel:PC2 -5300S5 55-12)
2	Toshiba(Model: LTD121E XEV)	Genuine intel U2500 1.2GHz	EPS (Model: F10903-A)	Toshiba (Model:MK1234GSX) 120G	Conexant (Model: RD-02-D330)	Intel(Model :WM3945 ABG)	MITAC(M odel:BP-L C2600/33-0 151)	Hnnix(M odel:PC2 -5300S5 55-12)

All types of LCD 、 CPU 、 Adapter Type 、 Hard Disk 、 Modem Card 、 Wireless LAN Card 、 Battery 、 DDR with related components have been tested, only shown the worst data using the following configuration in this report.

configuration	LCD	CPU	Adapter Type	Hard Disk	Modem Card	Wireless LAN Card	Battery	DDR
2	Toshiba(Model: LTD121E XEV)	Genuine intel U2500 1.2GHz	EPS (Model: F10903-A)	Toshiba (Model:MK1234GSX) 120G	Conexant (Model: RD-02-D330)	Intel(Model :WM3945 ABG)	MITAC(M odel:BP-L C2600/33-0 151)	Hnnix(M odel:PC2 -5300S5 55-12)

EMI Noise Source:

- GPS board Crystal: 12MHz(X1)
- Touch Panel board Crystal:7.372MHz(X1)
- SD card board Crystal:12MHz(X2)
- Main board Crystal:25MHz(X3),10MHz(X2),14.318MHz(X501)
- Clock Generator: U514

EMI Solution:

1. Adding shielded tape on LCD Signal cable
2. Adding Gasket on LCD Signal cable
3. Adding Gasket on LCD Panel around
4. Adding Gasket on Bluetooth Module
5. Adding aluminum foil on 3GCDMA antenna
6. Adding Copper on Main board
7. Adding Copper on Modem Card
8. Adding Gasket on Main board
9. Adding Gasket on Modem Card
10. Adding Core(A5 FS 16*5*12) on LAN Signal cable
11. Adding Core(A3 FS 15*3*11) on Modem Card Signal cable
12. Adding Core(K5B RH 6.35*15.8*3.3) on DC IN Jack
13. Adding aluminum foil on Case
14. Adding Core(FPC 40*2.7*12-K) on Keyboard Signal cable
15. Adding Core(RC 16*28*9 -M2) on Adapter Type Signal cable

3. Description of Support Equipment

3.1 Description of Support Equipment

Unit	Model Serial No.	Brand	Power Cord	FCC ID
Aceex Modem	DM1414 S/N: 0301000557	Aceex	Nonshielded Detachable	FCC DOC
Aceex Modem	DM1414 S/N: 0301000557	Aceex	Nonshielded Detachable	FCC DOC
Bluetooth test set	Mt8852B S/N: 6K00004613	Anritsu	Shielded Detachable	NA
External Hard Disk Case	F12-UF S/N: NA	TeraSys	Nonshielded Detachable	FCC DOC
External Hard Disk Case	F12-UF S/N: NA	TeraSys	Nonshielded Detachable	FCC DOC
ATA Microphone and HeadSet	1221K S/N: NA	ATA	NA	FCC DOC

3.1.1 Software for Controlling Support Unit

Test programs exercising various part of EUT were used. The programs were executed as follows:

- A. Read and write to the disk drives.
- B. The RF software makes the transmitter continuously sending RF signals
- C. Link with the Bluetooth test set makes the transmitter continuously sending RF signals.(EDR mode)
- D. Repeat the above steps.

	Filename	Issued Date
CSR Bluesuite V1.20.0.0	Bluetest.exe	2004/04/08

3.1.2 I/O Cable Condition of EUT and Support Units

Description	Path	Cable Length	Cable Type	Connector Type
AC Power Cord	110V (~240V) to EUT SPS	1.8M	Nonshielded, Detachable	Plastic Head
AC Power Cord	110V (~240V) to BT test set SPS	1.8M	Shielded, Detachable	Plastic Head
Modem Data Cable*2	Modem to PC COM 1 port	1.5M	Shielded, Detachable	Metal Head
USB Data Cable*2	USB external hard disk to EUT USB Port	1.8M	Shielded, Un-detachable	Metal Head
Audio Data Cable	Microphone and HeadSet to EUT Line In Port and Line Out Port	1.8M	Non-shielded, Un-Detachable	Plastic Head

4. TEST RESULTS (Bluetooth)

4.1 Powerline Conducted Emissions

4.1.1 EUT Configuration

The EUT was set up on the non-conductive table that is 1.0 by 1.5 meter, 80cm above ground. The wall of the shielded room was located 40cm to the rear of the EUT.

Power to the EUT was provided through the LISN. The impedance vs. frequency characteristic of the LISN is complied with the limit used.

Both lines (neutral and hot) were connected to the LISN in series at testing. A coaxial-type connector which provides one 50 ohms terminating impedance was provided for connecting the test instrument. The excess length of the power cord was folded back and forth at the center of the lead so as to form a bundle not exceeding 40cm in length.

Any changes made to the configuration, or modifications made to the EUT, during testing are noted in the following test record.

If the EUT is a Personal Computer or a peripheral of personal computer, and the personal computer has an auxiliary AC outlet which can be used for providing power to an external monitor, then all measurements will be made with the monitor power from first the computer-mounted AC outlet and then a floor-mounted AC outlet.

4.1.2 Test Procedure

The system was set up as described above, with the EMI diagnostic software running. The main power line conducted EMI tests were run on the hot and neutral conductors of the power cord and the results were recorded. The effect of varying the position of the interface cables has been investigated to find the configuration that produces maximum emission.

At the frequencies where the peak values of the emissions were higher than 6dB below the applicable limits, the emissions were also measured with the quasi-peak detectors. At the frequencies where the quasi-peak values of the emissions were higher than 6dB below the applicable average limits, the emissions were also measured with the average detectors.

The highest emissions were analyzed in details by operating the spectrum analyzer in fixed tuned mode to determine the nature of the emissions and to provide information which could be useful in reducing their amplitude.

4.1.3 EMI Receiver/Spectrum Analyzer Configuration (for the frequencies tested)

Frequency Range	150 KHz--30MHz
Detector Function	Quasi-Peak/Average
Bandwidth (RBW)	9KHz

4.1.4 Test Data:

Power Line Conducted Emissions (Hot) Channel 00, 39, 78



Address: No.120, Lane 180, San Ho Tsuen, Hsin Ho Road, Lung-Tan Hsiang,
Tao Yuan Conty, Taiwan R.O.C.
Tel: 03-4071718

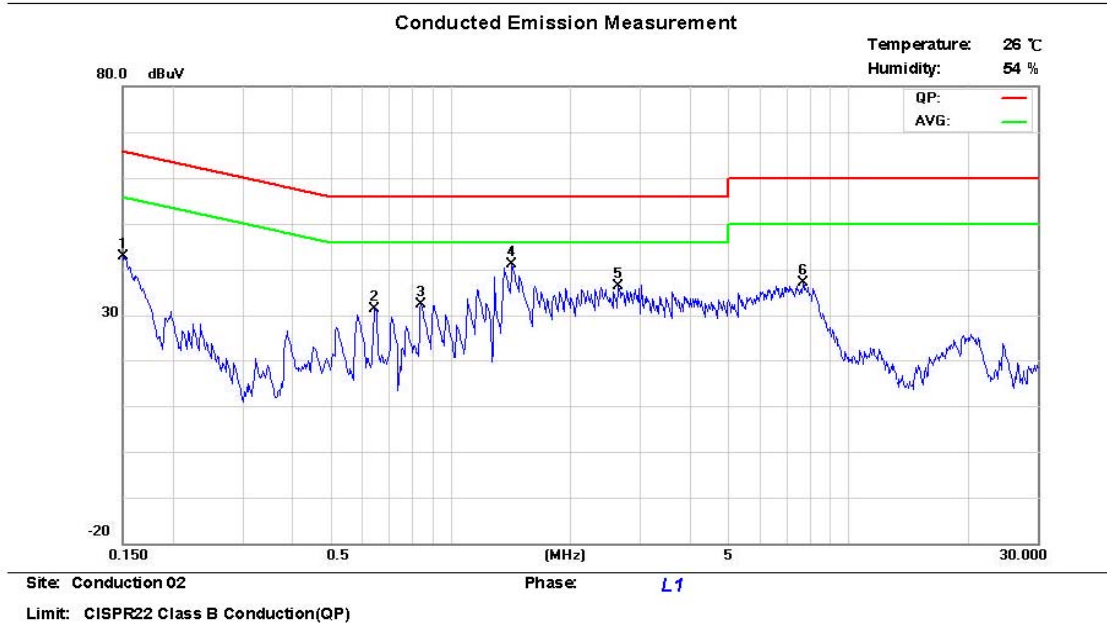

Frequency MHz	LISN Loss dB	Cable Loss dB	QP Correct dBuV	QP Limit dBuV	QP Margin dB	AVG Correct. dBuV	AVG Limit dBuV	AVG Margin dB	Note
0.1500	0.1	0.02	43.30	65.9	-22.6	39.90	55.9	-16.0	
0.6440	0.2	0.07	32.90	56.0	-23.1	30.60	46.0	-15.4	
0.8438	0.2	0.07	33.40	56.0	-22.6	31.40	46.0	-14.6	
* 1.4256	0.2	0.08	41.40	56.0	-14.6	36.10	46.0	-9.90	
2.6500	0.26	0.11	36.20	56.0	-19.8	34.60	46.0	-11.4	
7.6870	0.46	0.18	40.00	60.0	-20.0	35.80	50.0	-14.2	

*:Maximum data x:Over limit

Power Line Conducted Emissions (Neutral) Channel 00, 39, 78



Address: No.120, Lane 180, San Ho Tsuen, Hsin Ho Road, Lung-Tan Hsiang,
Tao Yuan Conty, Taiwan R.O.C.
Tel: 03-4071718

Conducted Emission Measurement

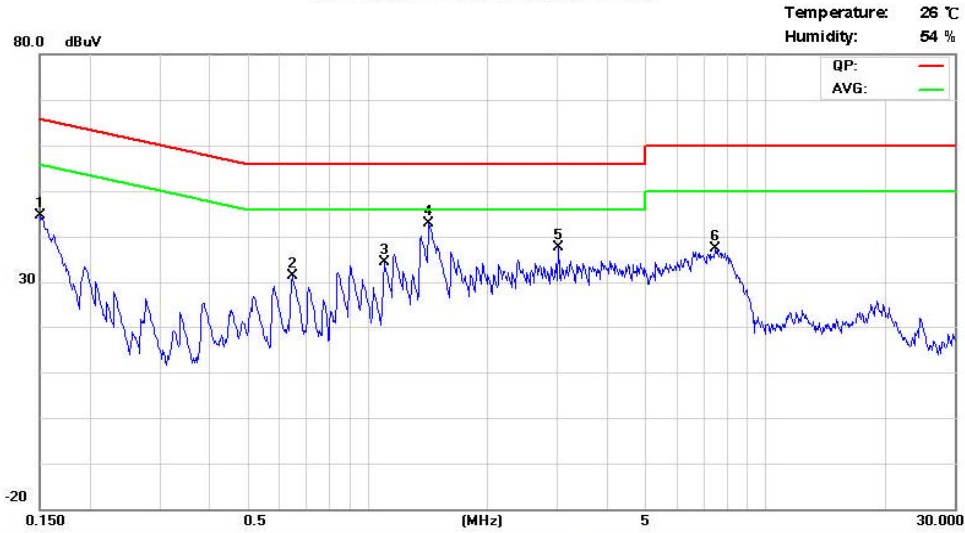

Site: Conduction 02

Phase: N

Limit: CISPR22 Class B Conduction(QP)

Frequency MHz	LISN Loss dB	Cable Loss dB	QP Correct dBuV	QP Limit dBuV	QP Margin dB	AVG Correct. dBuV	AVG Limit dBuV	AVG Margin dB	Note
0.1500	0.1	0.02	42.30	65.9	-23.6	39.40	55.9	-16.5	
0.6474	0.2	0.07	33.60	56.0	-22.4	31.00	46.0	-15.0	
1.0997	0.2	0.07	36.70	56.0	-19.3	33.40	46.0	-12.6	
* 1.4226	0.2	0.08	41.90	56.0	-14.1	40.70	46.0	-5.30	
3.0253	0.2	0.12	26.70	56.0	-29.3	22.30	46.0	-23.7	
7.4860	0.32	0.18	36.20	60.0	-23.8	30.20	50.0	-19.8	

*:Maximum data x:Over limit

* NOTE: During the test, the EMI receiver was set to Max. Hold then switch the EUT Channel between 00, 39, 78 to get the maximum reading of all these channels.
Margin = Amplitude + Insertion Loss- Limit
A margin of -8dB means that the emission is 8dB below the limit

4.2 FHSS Maximum Peak Output Power

4.2.1 Test Procedure

The Transmitter output of EUT was connected to the Spectrum analyzer.
The test performed in accordance with FCC document “Filing and Measurement Guidelines for Frequency Hopping Spread Spectrum Systems”, March 30, 2000.

Equipment mode	Spectrum analyzer
Detector function	Peak
RBW	> the 20 dB bandwidth of the emission being measured
VBW	≥ RBW
SPAN	approximately 5 times the 20 dB bandwidth
Center frequency	fundamental frequency tested
Sweep time	auto

4.2.2 Test Setup

Condition 1:



Condition 2:

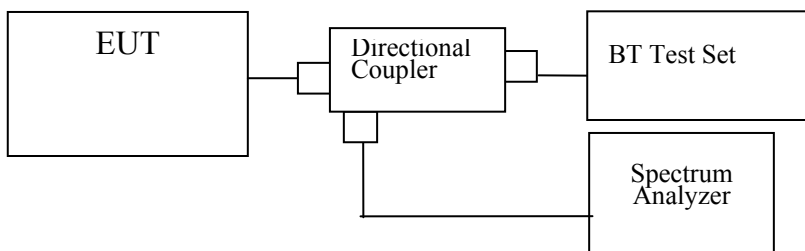

4.2.3 Test Data

Maximum Peak Output Power

Data Rate: 1Mbps

Temperature (°C):25

Test Engineer:Jerry Chiou

Humidity (%):55

Channel	Frequency (Mhz)	Analyzer Reading (dBm)	Cable Loss (dB)	Peak Power Output (mW)	Peak Power Output (dBm)	Limit (dBm)	Pass/Fail
00	2402	2.17	1.10	2.12	3.27	30	Pass
39	2441	3.11	1.10	2.64	4.21	30	Pass
78	2480	3.34	1.10	2.78	4.44	30	Pass

Data Rate: 2Mbps

EDR mode

Temperature (°C):25

Test Engineer:Jerry Chiou

Humidity (%):55

Channel	Frequency (Mhz)	Analyzer Reading (dBm)	Cable Loss (dB)	Peak Power Output (mW)	Peak Power Output (dBm)	Limit (dBm)	Pass/Fail
00	2402	-0.13	1.10	1.25	0.97	30	Pass
39	2441	0.20	1.10	1.35	1.30	30	Pass
78	2480	-0.32	1.10	1.20	0.78	30	Pass

Data Rate: 3Mbps

EDR mode

Temperature (°C):25

Test Engineer:Jerry Chiou

Humidity (%):55

Channel	Frequency (Mhz)	Analyzer Reading (dBm)	Cable Loss (dB)	Peak Power Output (mW)	Peak Power Output (dBm)	Limit (dBm)	Pass/Fail
00	2402	0.13	1.10	1.33	1.23	30	Pass
39	2441	0.47	1.10	1.44	1.57	30	Pass
78	2480	-0.09	1.10	1.26	1.01	30	Pass

Data Rate=1Mbps,Channel 00

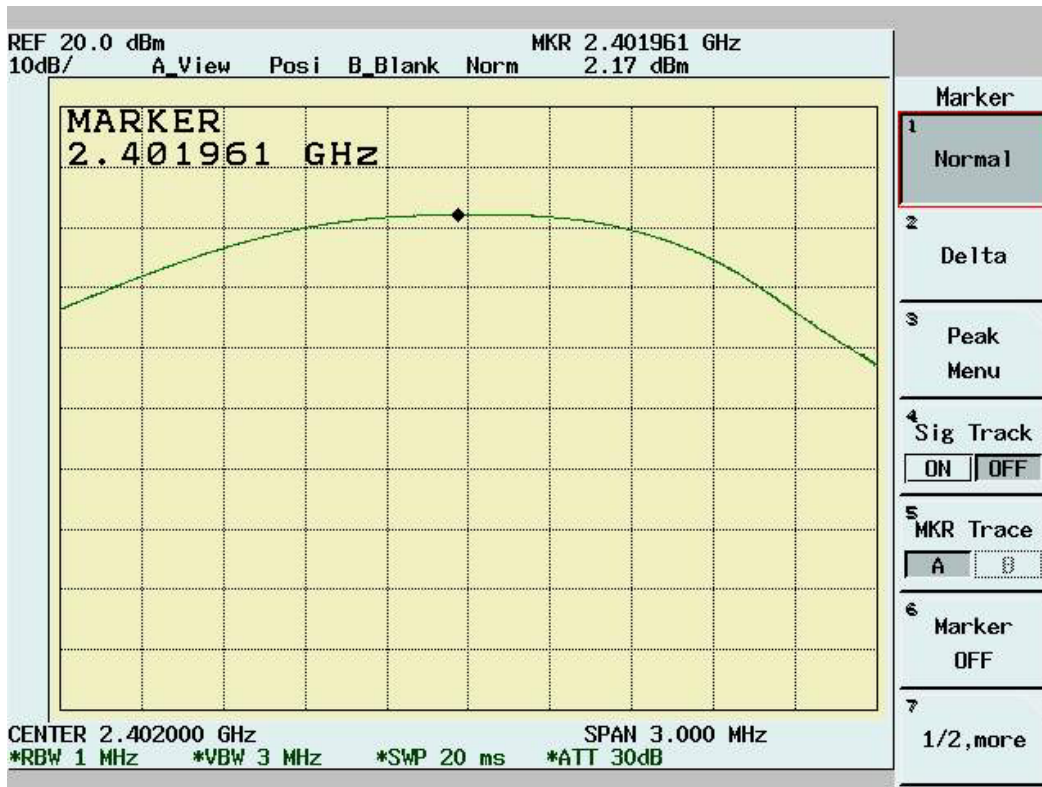

Data Rate=1Mbps,Channel 39

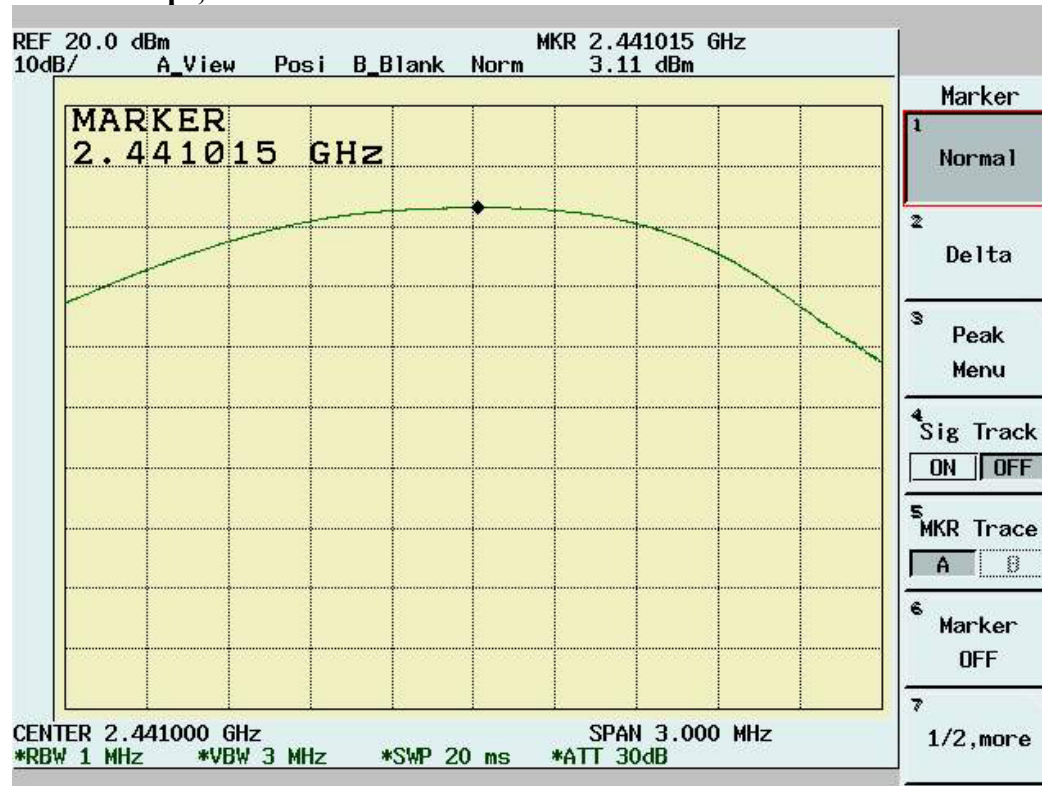

Data Rate=1Mbps,Channel 78

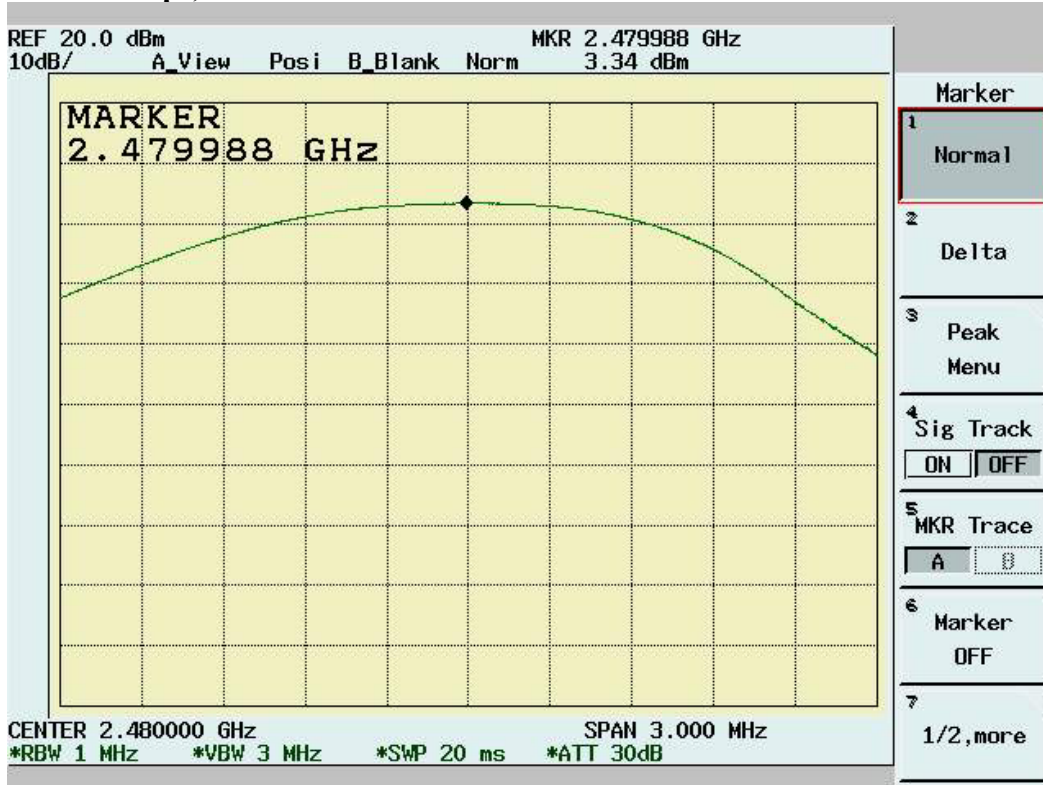

Data Rate=2Mbps,Channel 00

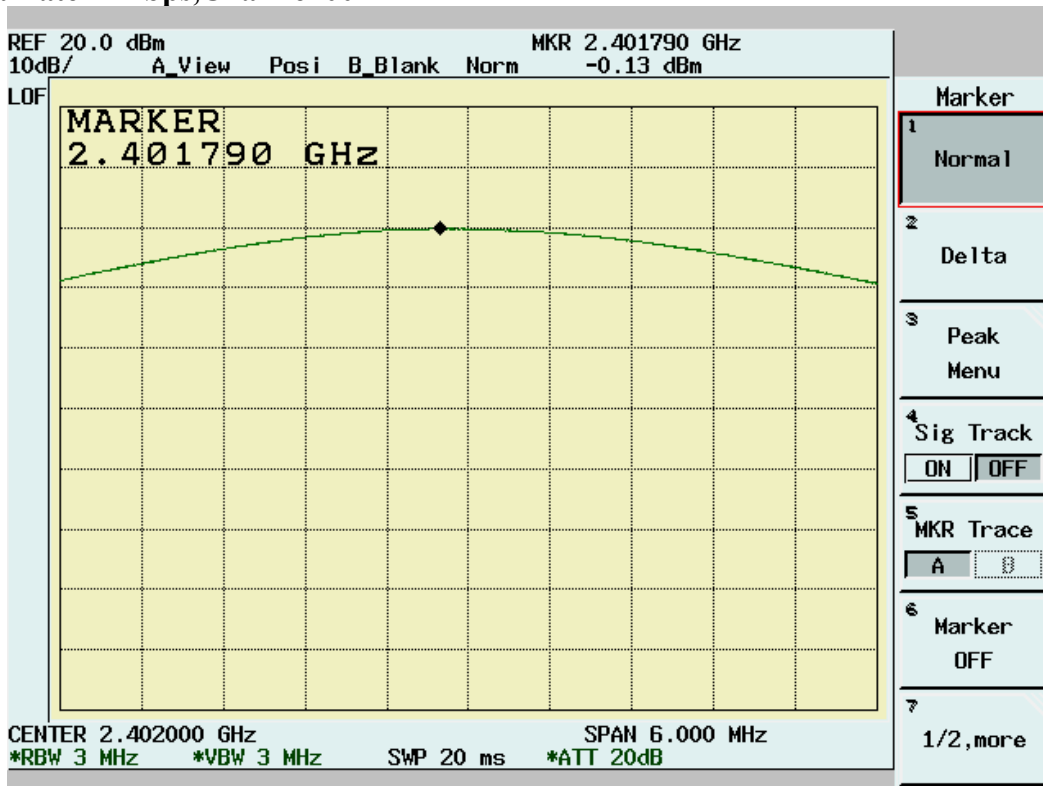

Data Rate=2Mbps,Channel 39

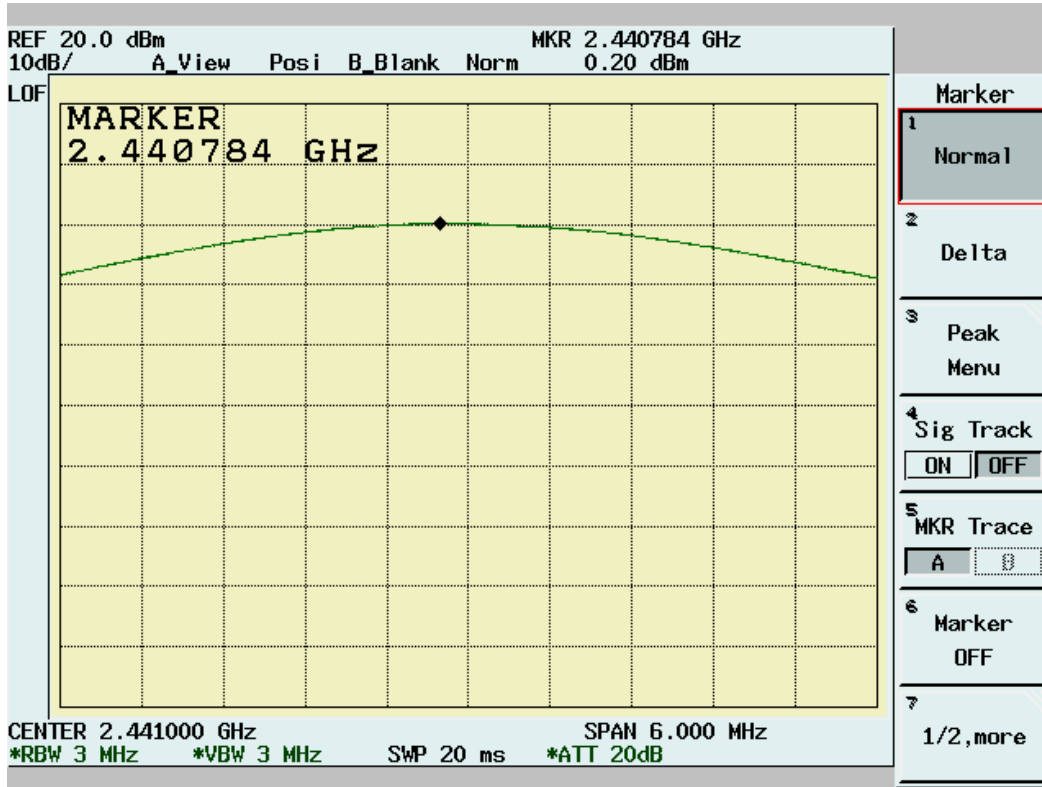

Data Rate=2Mbps,Channel 78

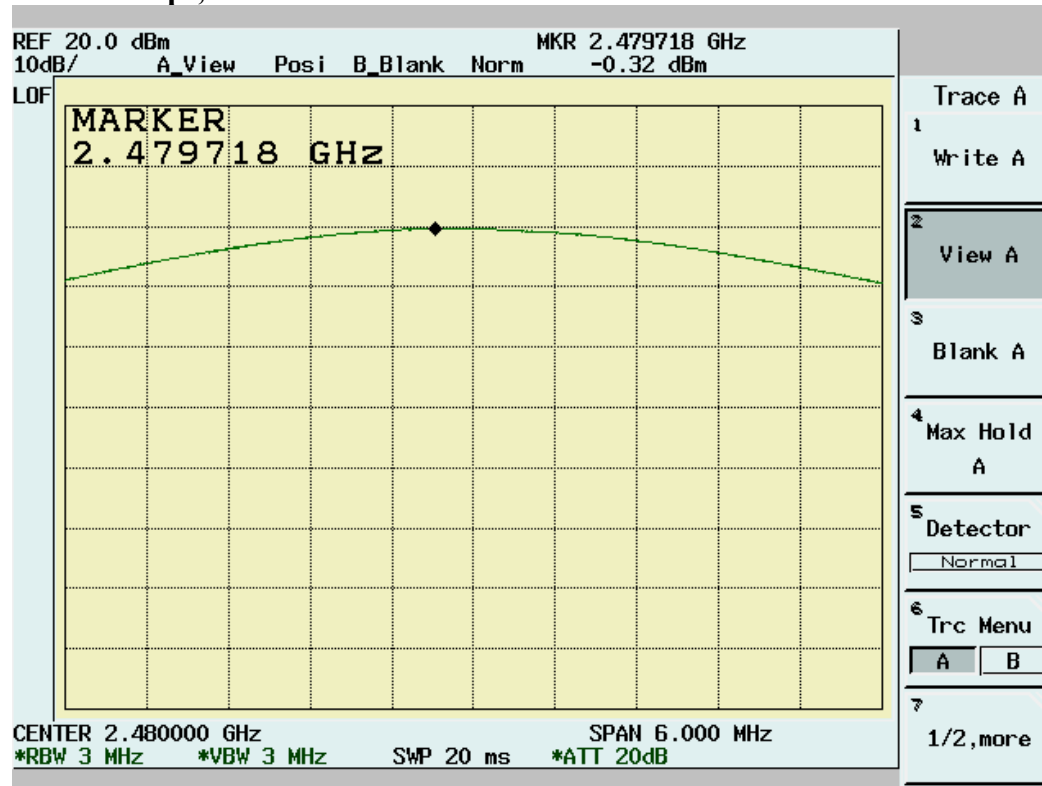

Data Rate=3Mbps,Channel 00

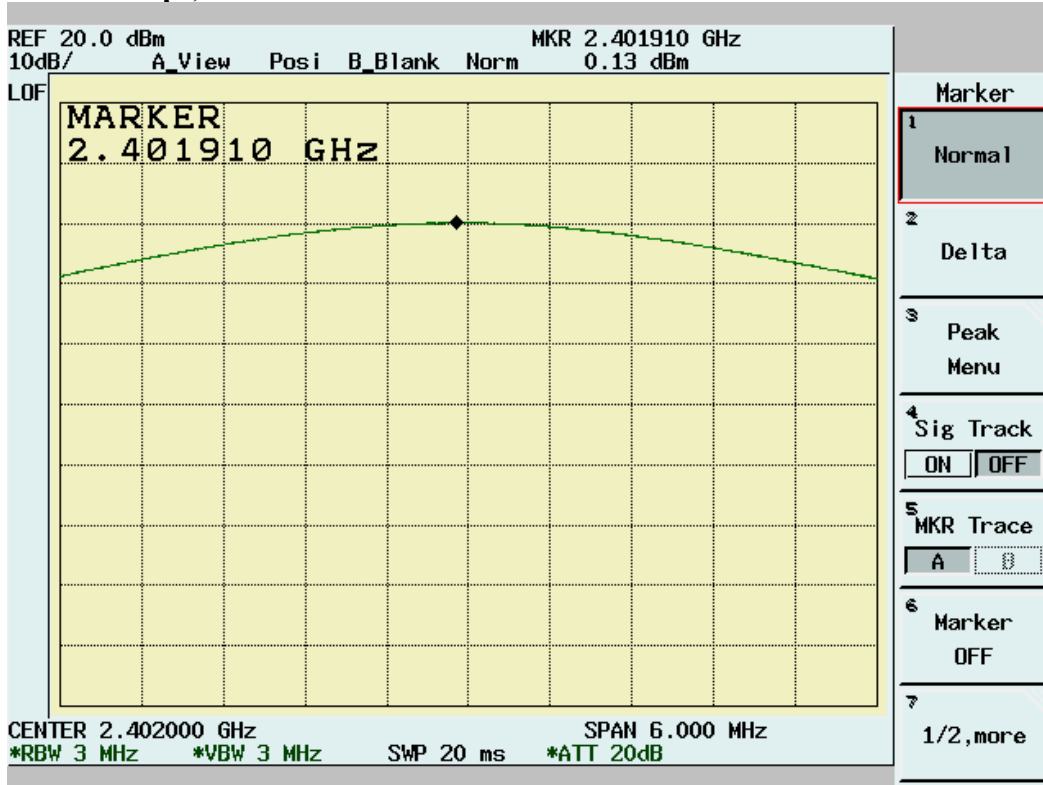

Data Rate=3Mbps,Channel 39

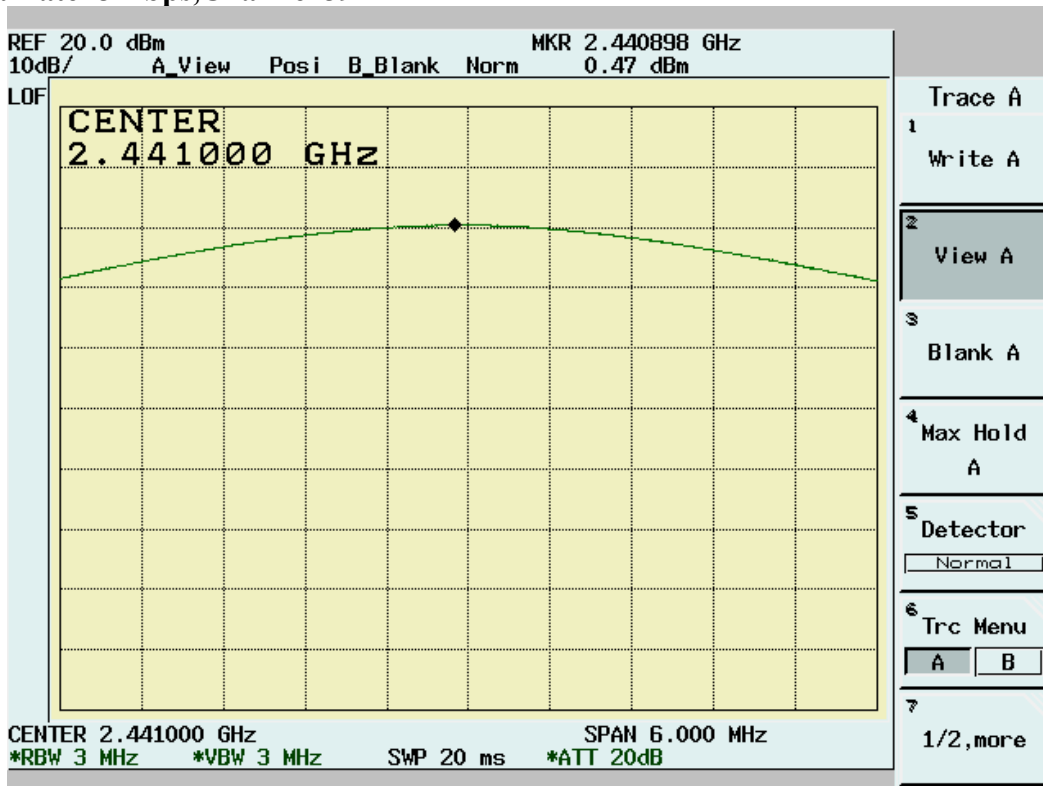

Data Rate=3Mbps,Channel 78

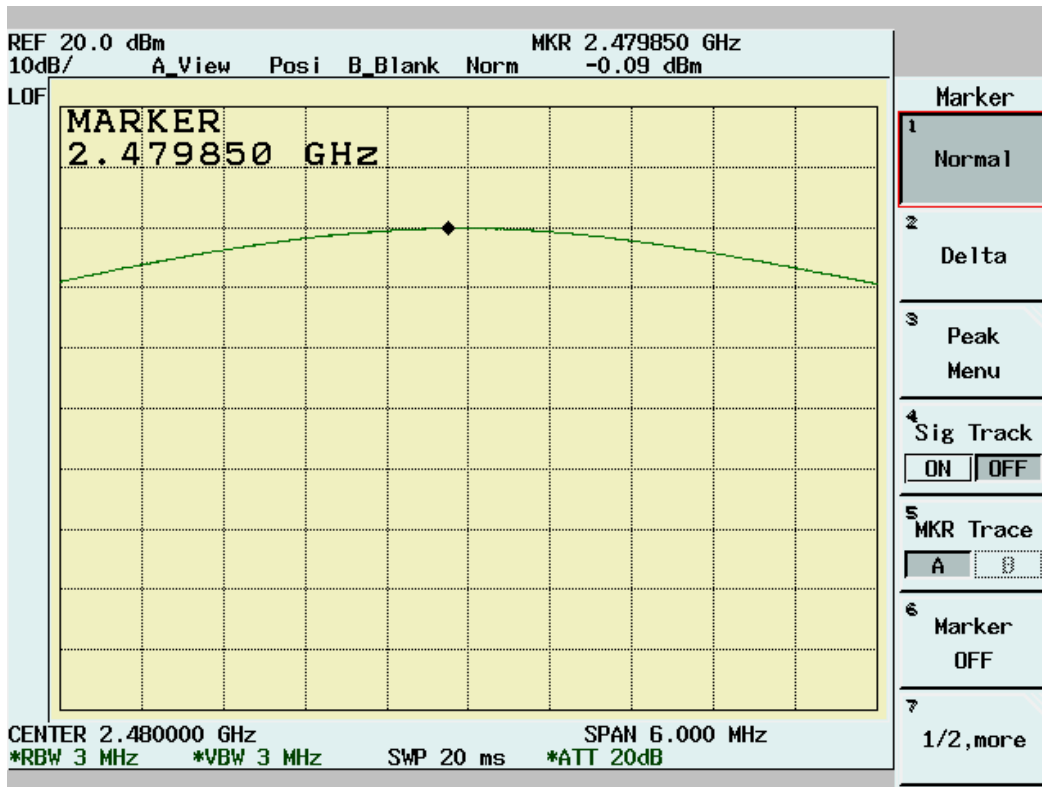

4.3 Radiated Emission Measurement

4.3.1 EUT Configuration

The equipment under test was set up on the 10 meter chamber with measurement distance of 3 meters. The EUT was placed on a non-conductive table 80cm above ground.

Any changes made to the configuration, or modifications made to the EUT, during testing are noted in the following test record.

4.3.2 Test Procedure

The system was set up as described above, with the EMI diagnostic software running. We found the maximum readings by varying the height of antenna and then rotating the turntable. Both polarization of antenna, horizontal and vertical, are measured.

30M to 1GHz: The highest emissions between 30 MHz to 1000 MHz were also analyzed in details by operating the spectrum analyzer and/or EMI receiver in quasi-peak mode to determine the precise amplitude of the emissions. While doing so, the interconnecting cables and major parts of the system were moved around, the antenna height was varied between one and four meters, its polarization was varied between vertical and horizontal, and the turntable was slowly rotated, to maximize the emission.

1GHz – 25GHz: The highest emissions were also analyzed in details by operating the spectrum analyzer and/or EMI receiver in peak mode to determine the precise amplitude of the emission. While doing so, the interconnecting cables and major parts of the system were moved around, the antenna height was varied between one and four meters, its polarization was varied between vertical and horizontal, and the turntable was slowly rotated, to maximize the emission. During test the EMI receiver and spectrum was setup according to EMI Receiver/Spectrum Analyzer Configuration.

For the test of 2nd to 10th harmonics frequencies, the equipment setup was also referred to EMI Receiver/Spectrum Analyzer Configuration. The frequencies were tested using Peak mode first, if the test data is higher than the emissions limit, an additional measurement using Average mode will be performed and the average reading will be compared to the limit and record in test report.

4.3.3 EMI Receiver/Spectrum Analyzer Configuration (for the frequencies tested)

Frequency Range Tested:	30MHz~1000MHz
Detector Function:	Quasi-Peak Mode
Resolution Bandwidth (RBW):	120KHz
Video Bandwidth (VBW)	1MHz

Frequency Range Tested:	1GHz – 25 GHz
Detector Function:	Peak Mode
Resolution Bandwidth (RBW):	1MHz
Video Bandwidth (VBW)	3MHz

Frequency Range Tested:	1GHz – 25 GHz
Detector Function:	Average Mode
Resolution Bandwidth (RBW):	1MHz
Video Bandwidth (VBW)	1KHz

4.3.4 Test Data (30MHz – 1GHz): With Data Rate= 1Mbps, DH5

30M – 1GHz Open Field Radiated Emissions (Horizontal) Channel 00, 39, 78

Operator: JerryChiou
Temperature(C):25
Humidity(%):63

Frequency MHz	RxAmp. (dBuV)	AntFac t (dB/m)	CableLos s (dB)	PreAmpGain (dB)	Corrct.Emi (dBuV/m)	Limit (dBuV/m)	Margin (dB)	Ant.Pos (cm)	TablePos (deg)
59.1	19.51	6.72	1.33	0	27.56	40	-12.44	96	33
68.8	20.84	6.16	1.51	0	28.52	40	-11.48	96	243
84.32	20.21	7.76	1.67	0	29.65	40	-10.35	96	191
88.2	20.36	8.54	1.67	0	30.57	43.5	-12.93	96	217
102.75	14.5	11.1	1.93	0	27.52	43.5	-15.98	96	33
105.66	14.23	11.62	1.93	0	27.78	43.5	-15.72	96	33
108.57	15.76	12.14	1.94	0	29.84	43.5	-13.66	96	33
111.48	17.76	12.43	1.9	0	32.09	43.5	-11.41	96	59
162.89	17.47	9.93	2.39	0	29.78	43.5	-13.72	96	217
919.49	5.15	20.66	5.32	0	31.12	46	-14.88	96	349

30M – 1GHz Open Field Radiated Emissions (Vertical) Channel 00, 39, 78

Operator: JerryChiou
Temperature(C):25
Humidity(%):63

Frequency MHz	RxAmp. (dBuV)	AntFac t (dB/m)	CableLos s (dB)	PreAmpGain (dB)	Corrct.Emi (dBuV/m)	Limit (dBuV/m)	Margin (dB)	Ant.Pos (cm)	TablePos (deg)
58.13	19.06	6.84	1.33	0	27.23	40	-12.77	96	217
68.8	21.68	6.16	1.51	0	29.35	40	-10.65	96	243
88.2	21.01	8.54	1.67	0	31.21	43.5	-12.29	96	217
102.75	15.16	11.1	1.93	0	28.18	43.5	-15.32	96	33
105.66	14.78	11.62	1.93	0	28.33	43.5	-15.17	96	33
108.57	14.5	12.14	1.94	0	28.58	43.5	-14.92	96	33
111.48	15.84	12.43	1.9	0	30.18	43.5	-13.32	96	59
155.13	16.47	10.15	2.31	0	28.93	43.5	-14.57	96	217
164.83	18.48	9.81	2.39	0	30.68	43.5	-12.82	96	217
197.81	16.39	9.16	2.6	0	28.14	43.5	-15.36	96	243

NOTE:

- During the Pre-test, the EUT has been tested for Channel 00, 39, 78 transmit from Main and Aux antenna respectively to get all the critical emission frequencies. In the final test all the critical emission frequencies has been tested and the test data are listed above.
- Margin = Corrected Amplitude – Limit
Corrected Amplitude = Radiated Amplitude + Antenna Correction Factor + Cable Loss - Pre-Amplifier Gain
A margin of -8dB means that the emission is 8dB below the limit

All frequencies from 30MHz to 1GHz have been tested

4.3.5 Test Data (1GHz – 25 GHz): With Data Rate= 1MBps, DH5

1GHz~ 25 GHz (Horizontal), Channel 00: 2402 MHz

Operator: JerryChiou
Temperature(C):25
Humidity(%):63

Frequency	RxAmp.	AntFac	CableLos	PreAmpGain	Corrct.Emi	Limit	Margin	Ant.Pos	TablePos
MHz	(dBuV)	(dB/m)	(dB)	(dB)	(dBuV/m)	(dBuV/m)	(dB)	(cm)	(deg)
1497	40.97pk	26.79	2.23	23.75	46.23pk	54.00av	-7.77	101	78
5064.44	30.23pk	34.88	5.07	27.28	42.90pk	54.00av	-11.1	100	18
9482.52	30.21pk	39.16	3.83	24.97	48.23pk	54.00av	-5.77	102	10

1GHz~ 25 GHz (Vertical), Channel 00: 2402 MHz

Operator: JerryChiou
Temperature(C):25
Humidity(%):63

Frequency	RxAmp.	AntFac	CableLos	PreAmpGain	Corrct.Emi	Limit	Margin	Ant.Pos	TablePos
MHz	(dBuV)	(dB/m)	(dB)	(dB)	(dBuV/m)	(dBuV/m)	(dB)	(cm)	(deg)
1596.9	40.42pk	27.61	2.3	23.75	46.59pk	54.00av	-7.41	101	71
1861.64	39.05pk	29.84	2.5	23.75	47.63pk	54.00av	-6.37	100	53
6817.18	31.57pk	37.82	3.89	26.89	46.39pk	54.00av	-7.61	101	142
9554.95	29.83pk	39	3.88	24.9	47.81pk	54.00av	-6.19	102	9

Note:

- According to the standards used, Where limits are specified by agencies for both average and peak (or quasi-peak) detection, if the peak (or quasi-peak) measured value complies with the average limit , it is unnecessary to perform an average measurement.
- The Spectrum noise level+Correction Factor < Limit - 6 dB
- Margin=Corrected Amplitude – Limit
- Corrected Amplitude=Radiated Amplitude+Antenna Correction Factor+Cable Loss-Pre-Amplifier Gain
- A margin of -8dB means that the emission is 8dB below the limit.

All frequencies from 1GHz to 25 GHz have been tested.

1GHz~ 25 GHz (Horizontal), Channel 39: 2441 MHz

Operator:JerryChiou
Temperature(C):25
Humidity(%):63

Frequency	RxAmp.	AntFact	CableLoss	PreAmpGain	Corrct.Emi	Limit	Margin	Ant.Pos	TablePos
MHz	(dBuV)	(dB/m)	(dB)	(dB)	(dBuV/m)	(dBuV/m)	(dB)	(cm)	(deg)
1497	41.54pk	26.79	2.23	23.75	46.80pk	54.00av	-7.2	101	78
4629.87	30.47pk	33.39	5.16	27.75	41.27pk	54.00av	-12.73	101	37
8526.47	29.77pk	41.08	3.8	26.37	48.29pk	54.00av	-5.71	102	131
9714.29	29.59pk	38.71	3.99	24.79	47.50pk	54.00av	-6.5	102	6

1GHz~ 25 GHz (Vertical) Channel 39: 2441 MHz

Operator:JerryChiou
Temperature(C):25
Humidity(%):63

Frequency	RxAmp.	AntFact	CableLoss	PreAmpGain	Corrct.Emi	Limit	Margin	Ant.Pos	TablePos
MHz	(dBuV)	(dB/m)	(dB)	(dB)	(dBuV/m)	(dBuV/m)	(dB)	(cm)	(deg)
1996.5	35.27pk	30.97	2.6	23.75	45.08pk	54.00av	-8.92	100	43
5035.46	30.28pk	34.84	5.09	27.26	42.96pk	54.00av	-11.04	100	10
7280.72	30.96pk	38.32	3.88	26.57	46.59pk	54.00av	-7.41	101	150
9757.74	30.16pk	38.64	4.02	24.76	48.05pk	54.00av	-5.95	101	5

Note:

- According to the standards used:Where limits are specified by agencies for both average and peak (or quasi-peak) detection , if the peak (or quasi-peak) measured value complies with the average limit , it is unnecessary to perform an average measurement.
- The Spectrum noise level+Correction Factor < Limit - 6 dB
- Margin=Corrected Amplitude – Limit
- Corrected Amplitude=Radiated Amplitude+Antenna Correction Factor+Cable Loss-Pre-Amplifier Gain
- A margin of -8dB means that the emission is 8dB below the limit.

All frequencies from 1GHz to 25 GHz have been tested.

1GHz~ 25 GHz (Horizontal), Channel 78: 2480 MHz

Operator: Jerry Chiou
Temperature(C): 25
Humidity(%): 63

Frequency	RxAmp.	AntFac	CableLos	PreAmpGain	Corrct.Emi	Limit	Margin	Ant.Pos	TablePos
MHz	(dBuV)	(dB/m)	(dB)	(dB)	(dBuV/m)	(dBuV/m)	(dB)	(cm)	(deg)
1497	42.03pk	26.79	2.23	23.75	47.29pk	54.00av	-6.71	101	78
4687.81	30.60pk	33.61	5.15	27.67	41.70pk	54.00av	-12.3	101	31
8511.99	29.65pk	41.09	3.8	26.38	48.16pk	54.00av	-5.84	102	135
10308.2	32.11pk	38.45	4.23	25.29	49.49pk	54.00av	-4.51	101	72

1GHz~ 25 GHz (Vertical), Channel 78 : 2480 MHz

Operator: Jerry Chiou
Temperature(C): 25
Humidity(%): 63

Frequency	RxAmp.	AntFac	CableLos	PreAmpGain	Corrct.Emi	Limit	Margin	Ant.Pos	TablePos
MHz	(dBuV)	(dB/m)	(dB)	(dB)	(dBuV/m)	(dBuV/m)	(dB)	(cm)	(deg)
1856.64	39.77pk	29.8	2.49	23.75	48.31pk	54.00av	-5.69	100	53
2006.49	35.38pk	31	2.58	23.76	45.19pk	54.00av	-8.81	100	45
6541.96	30.84pk	38.76	4.12	27.21	46.51pk	54.00av	-7.49	101	191
9250.75	29.40pk	39.9	3.72	25.35	47.67pk	54.00av	-6.33	102	15

Note:

- According to the standards used, Where limits are specified by agencies for both average and peak (or quasi-peak) detection, if the peak (or quasi-peak) measured value complies with the average limit, it is unnecessary to perform an average measurement.
- The Spectrum noise level + Correction Factor < Limit - 6 dB
- Margin = Corrected Amplitude - Limit
- Corrected Amplitude = Radiated Amplitude + Antenna Correction Factor + Cable Loss - Pre-Amplifier Gain
- A margin of -8dB means that the emission is 8dB below the limit.

All frequencies from 1GHz to 25 GHz have been tested.

4.4 Band Edge Measurement

4.4.1 Test Procedure

Conducted

1. The transmitter output of EUT was connected to the spectrum analyzer.
Equipment mode: Spectrum analyzer
Detector function: Peak mode
SPAN: 100MHz
RBW: 100KHz
VBW: 100KHz
Center frequency: 2.375GHz, 2.5GHz.
2. Using Peak Search to read the peak power of Carrier frequencies after Maximum Hold function is completed
3. Find the next peak frequency outside the operation frequency band

Radiated

1. Antenna and Turntable test procedure same as Radiated Emission Measurement.
Equipment mode: Spectrum analyzer
Detector function: Peak mode
SPAN: 100MHz
RBW: 100KHz
VBW: 100KHz
Center frequency: 2.375GHz, 2.5GHz.
2. Using Peak Search to read the peak power of Carrier frequencies after Maximum Hold function is completed
3. Find the next peak frequency outside the operation frequency band

4.4.2 Test Setup

Conducted

Condition 1:



Condition 2:

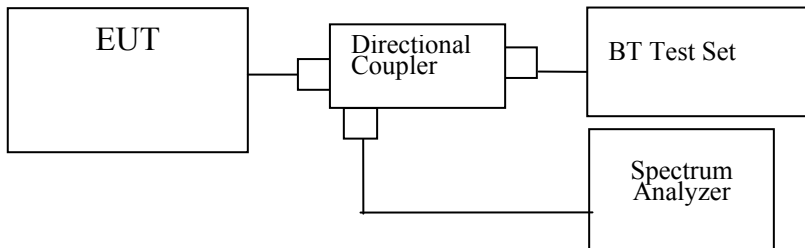

Radiated

Same as *Radiated Emission Measurement*

4.4.3 Test Data:

Test condition: Data Rate= 1Mbps, DH5

Table: Band Edge measurement

Conducted Test

Temperature (°C):25

Test Engineer:Jerry Chiou

Humidity (%):55

Channel	Frequency	Spectrum Reading	Carrier - Outsideband Limit: >20dB	Pass/Fail
	(MHz)	(dBuV)	(dB)	
00	2401.8	108.82	---	---
Outside band	2400	66.3	42.52	Pass
78	2479.8	109.97	---	---
Outside band	2484	64.8	45.17	Pass

Radiated Test

Temperature (°C):25

Test Engineer:Jerry Chiou

Humidity (%):60

Channel	Frequency	Spectrum Reading	Carrier - Outsideband Limit: >20dB	Pass/Fail
	(MHz)	(dBuV)	(dB)	
00	2402	48.34	---	---
Outside band	2400	10.22	38.12	Pass
78	2480	46.28	---	---
Outside band	2484	6.3	39.98	Pass

Band Edge Conducted Measurement

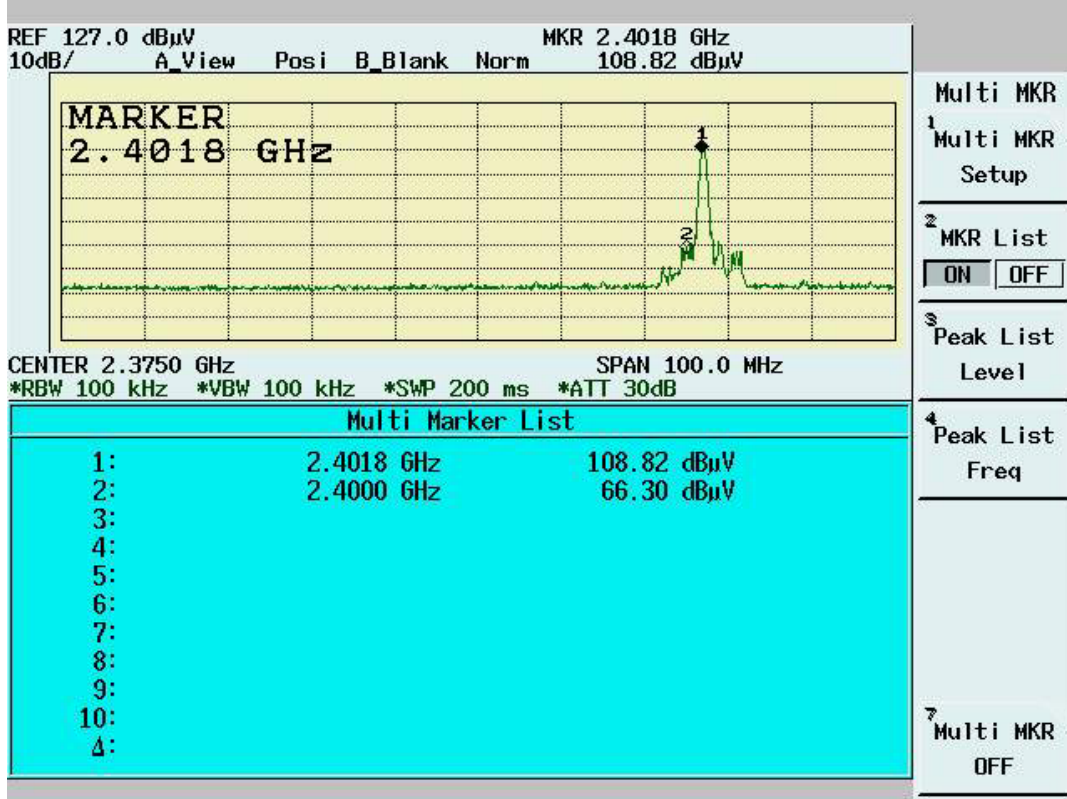

Band Edge Conducted Measurement

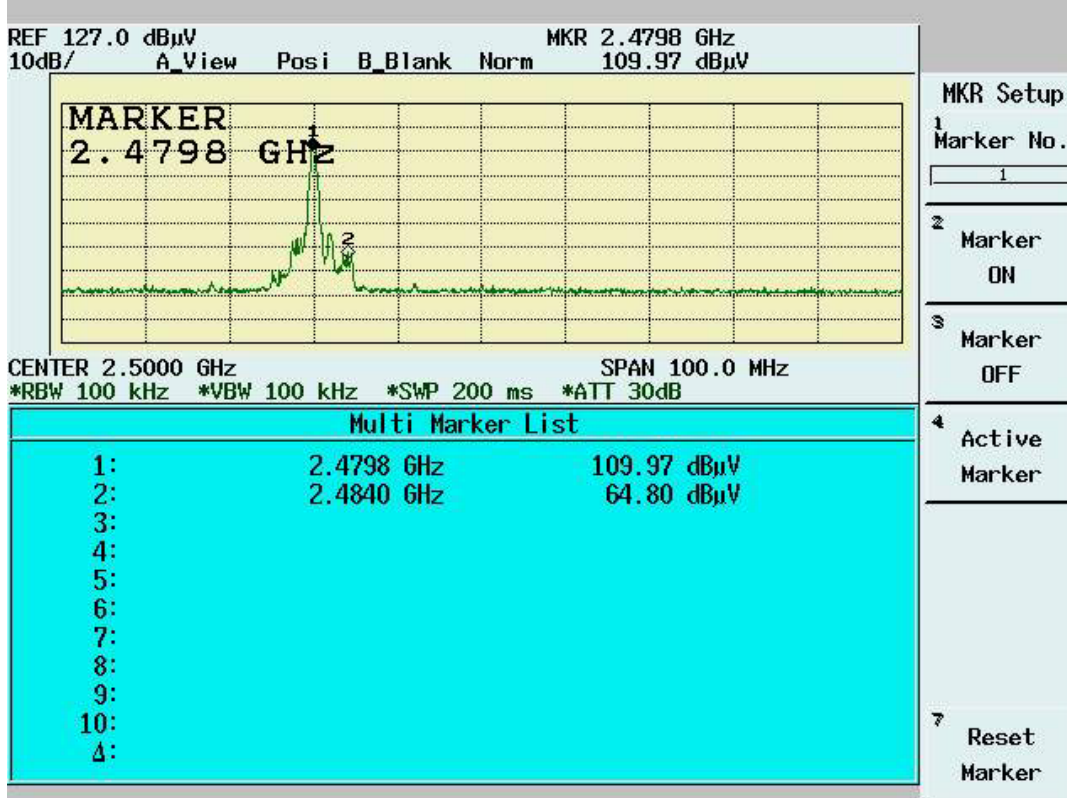

Band Edge Radiated Measurement

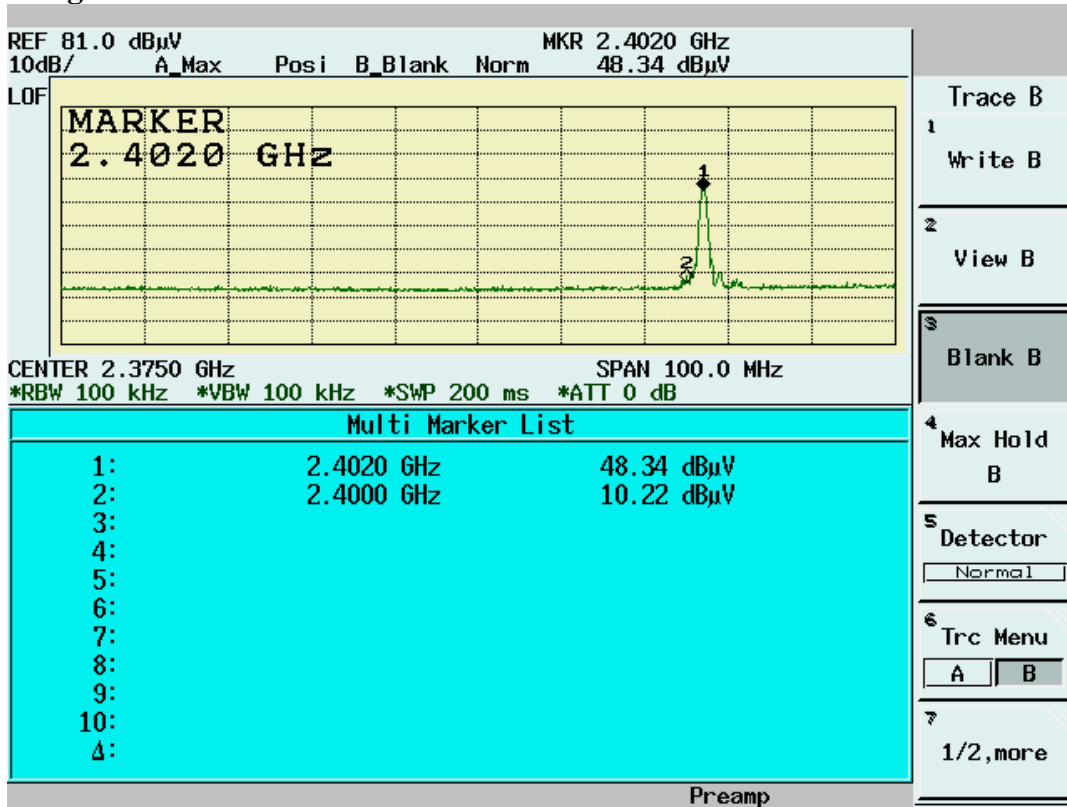

Band Edge Radiated Measurement

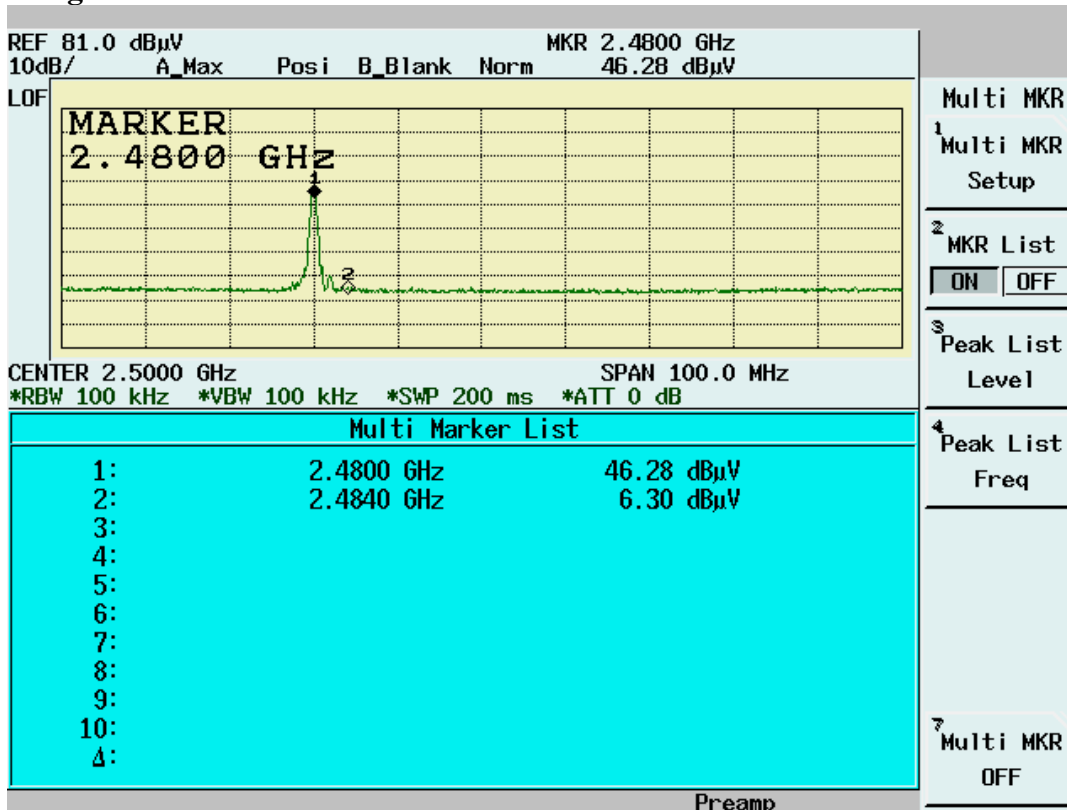

Test condition: Data Rate= 2Mbps, DH5

Table: Band Edge measurement

Conducted Test

Temperature (°C):25

Test Engineer:Jerry Chiou

Humidity (%):55

Channel	Frequency (MHz)	Spectrum Reading (dBuV)	Carrier - Outsideband Limit: >20dB (dB)	Pass/Fail
00	2401.9	106.41	---	---
Outside band	2400	56.63	49.78	Pass
78	2480	106.48	---	---
Outside band	2483.5	62.4	44.08	Pass

Radiated Test

Temperature (°C):25

Test Engineer:Jerry Chiou

Humidity (%):60

Channel	Frequency (MHz)	Spectrum Reading (dBuV)	Carrier - Outsideband Limit: >20dB (dB)	Pass/Fail
00	2402	55.34	---	---
Outside band	2400	8.84	46.5	Pass
78	2479.8	46.81	---	---
Outside band	2483.5	5.85	40.96	Pass

Band Edge Conducted Measurement

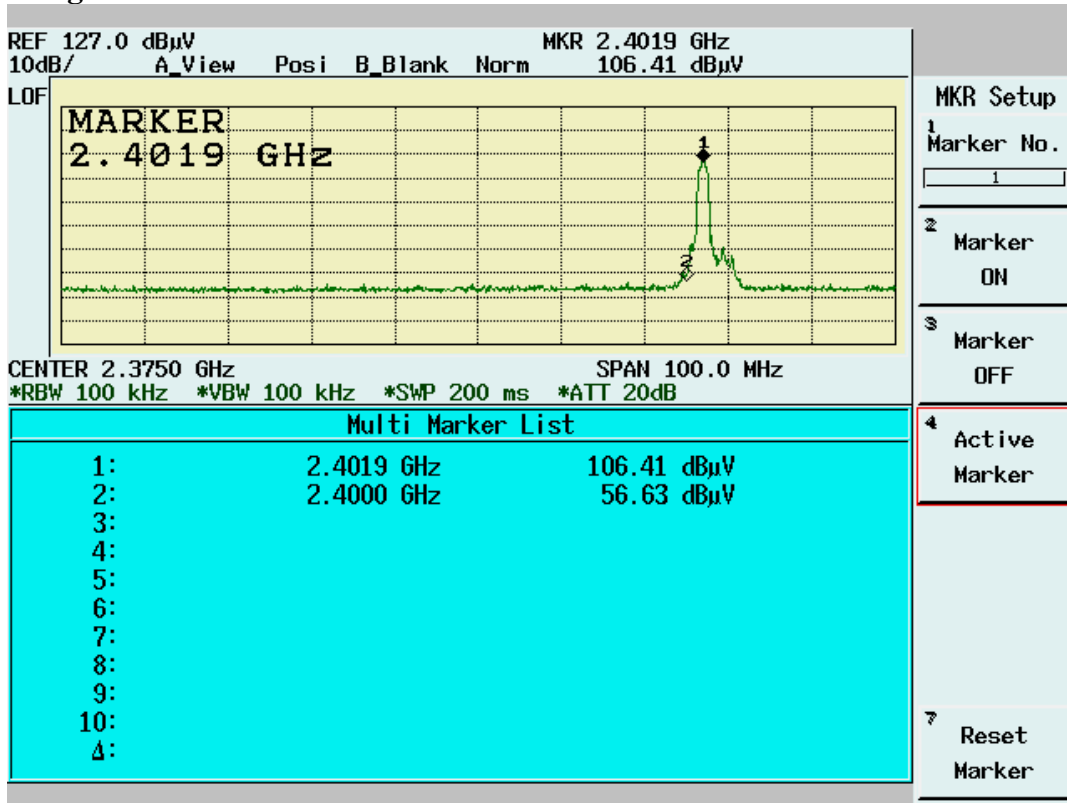

Band Edge Conducted Measurement

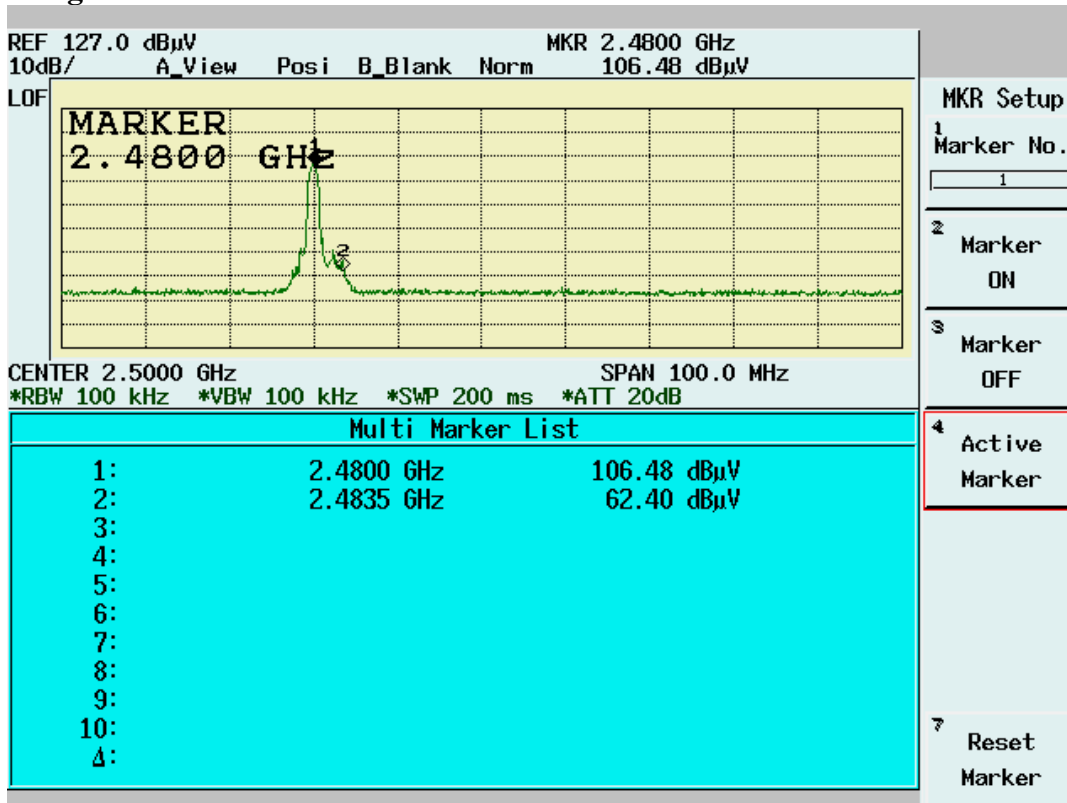

Band Edge Radiated Measurement

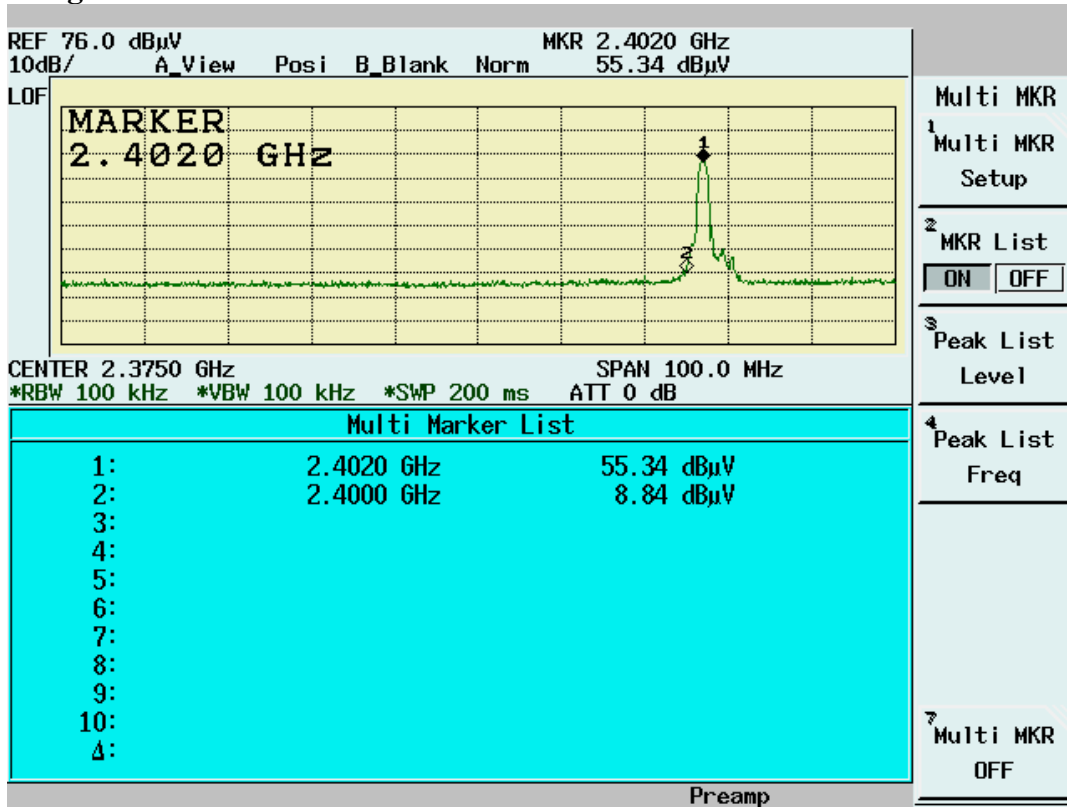

Band Edge Radiated Measurement

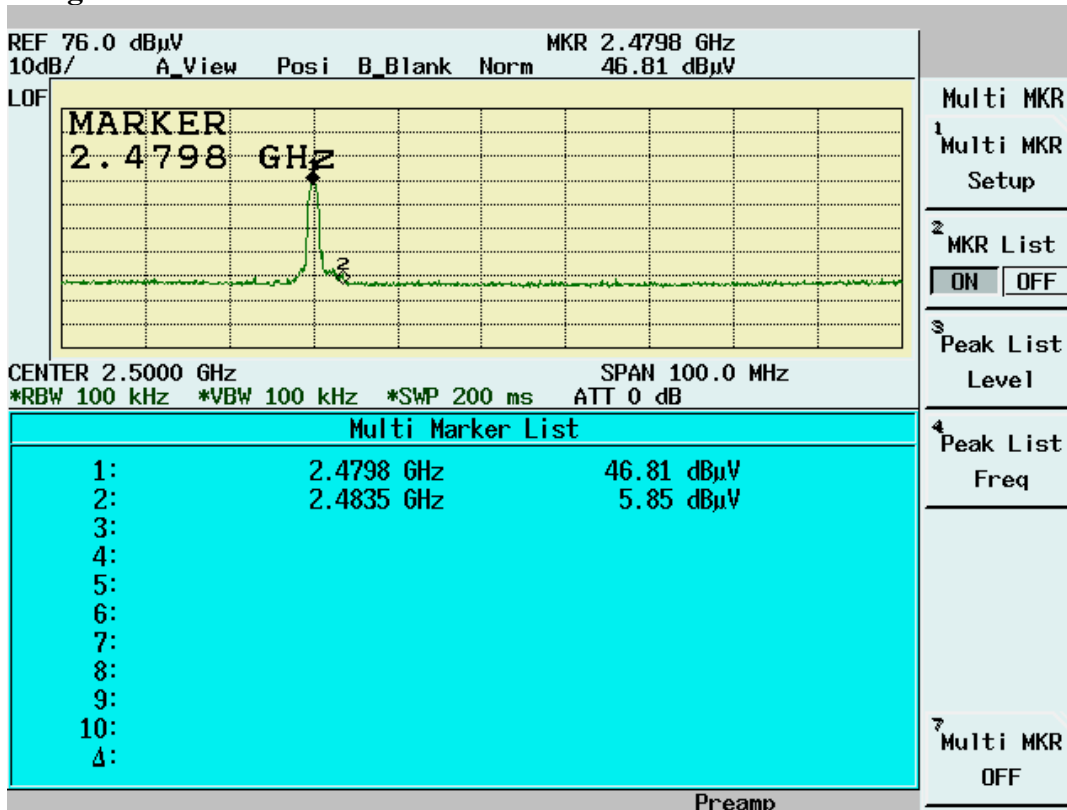

Test condition: Data Rate= 3Mbps, DH5

Table: Band Edge measurement

Conducted Test

Temperature (°C):25

Test Engineer:Jerry Chiou

Humidity (%):55

Channel	Frequency (MHz)	Spectrum Reading (dBuV)	Carrier - Outsideband Limit: >20dB (dB)	Pass/Fail
00	2401.9	106.21	---	---
Outside band	2400	56.93	49.28	Pass
78	2479.9	106.3	---	---
Outside band	2483.5	61.36	44.94	Pass

Radiated Test

Temperature (°C):25

Test Engineer:Jerry Chiou

Humidity (%):60

Channel	Frequency (MHz)	Spectrum Reading (dBuV)	Carrier - Outsideband Limit: >20dB (dB)	Pass/Fail
00	2402	55.02	---	---
Outside band	2400	9.24	45.78	Pass
78	2479.9	45.7	---	---
Outside band	2483.5	4.82	40.88	Pass

Band Edge Conducted Measurement

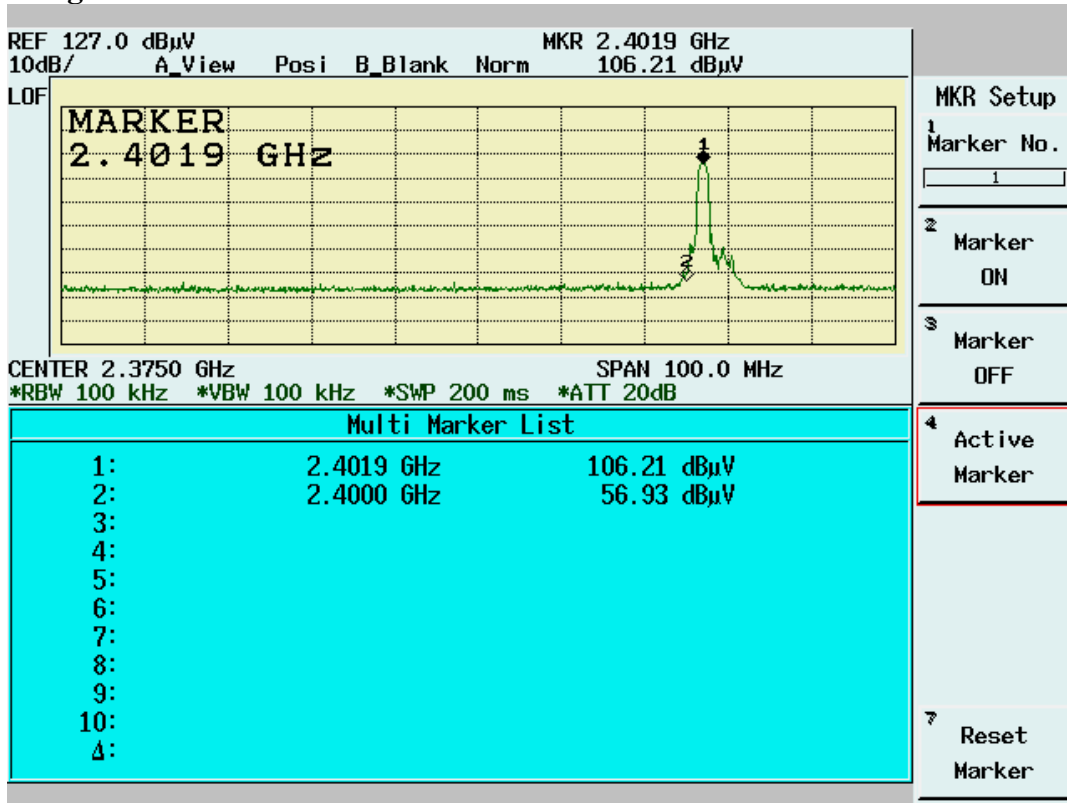

Band Edge Conducted Measurement

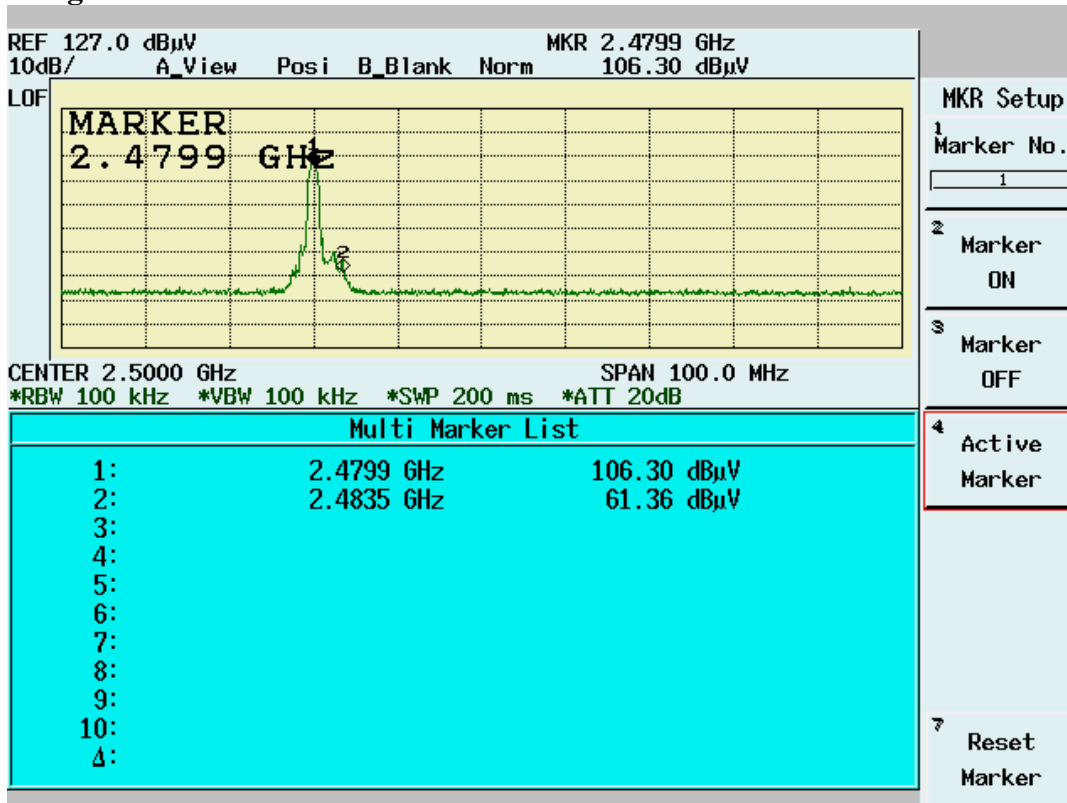

Band Edge Radiated Measurement

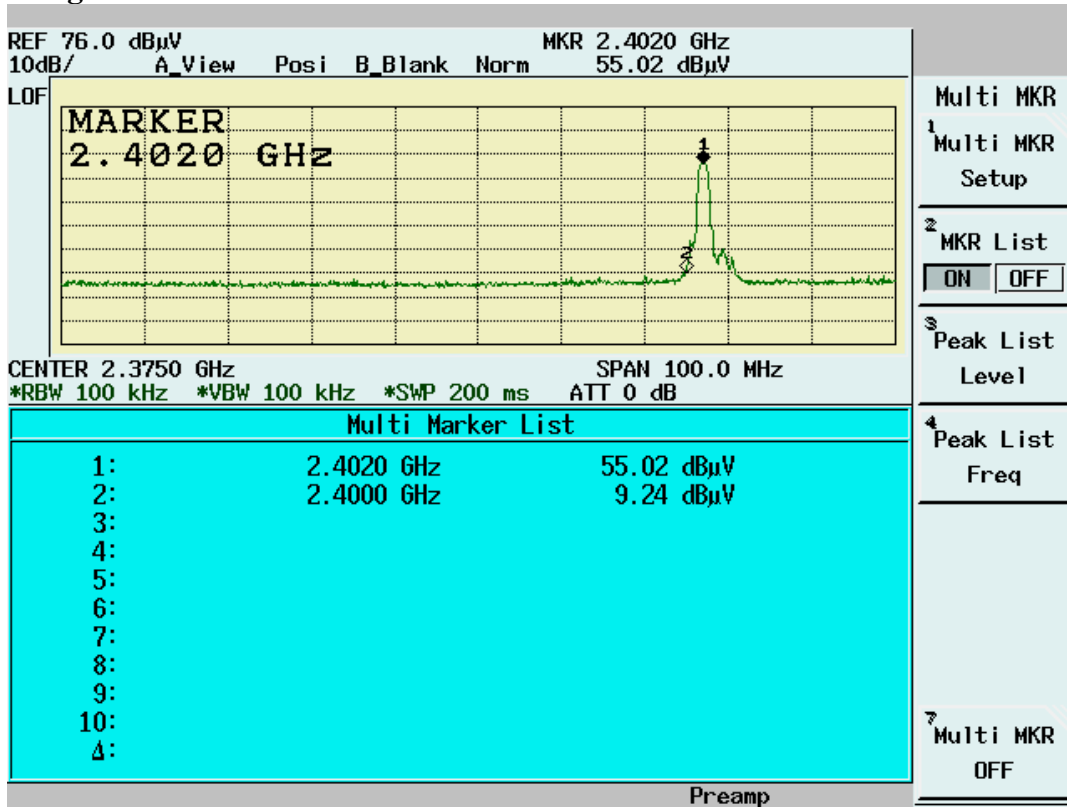

Band Edge Radiated Measurement

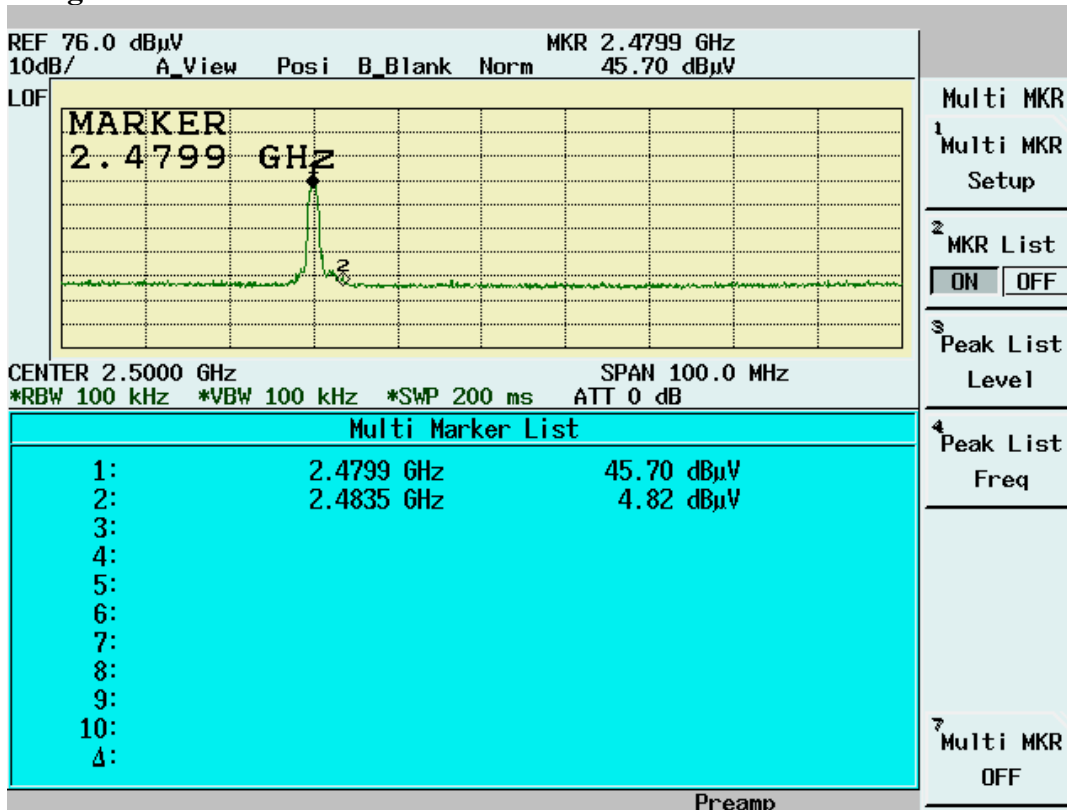

4.5 Restricted Bands Measurement

4.5.1 Test Procedure (Radiated)

1. Antenna and Turntable test procedure same as Radiated Emission Measurement.
Equipment mode: Spectrum analyzer
Detector function: Peak mode
SPAN: 100MHz
RBW: 1MHz
VBW: 3MHz
Center frequency: 2.375GHz, 2.5GHz.
2. Using Peak Search to read the peak power of Carrier frequencies after Maximum Hold function is completed.
3. Find the next peak frequency outside the operation frequency band
4. For peak frequency emission level measurement in Restricted Band,
Change RBW: 1MHz
VBW: 1KHz
Span: 100MHz.
5. Get the spectrum reading after Maximum Hold function is completed.

4.5.2 Test Setup (Radiated)

Same as *Radiated Emission Measurement*

4.5.3 Test Data

Test condition: Data Rate= 1Mbps, DH5

Table Restricted Bands measurement (Radiated)

Temp. (° C): 25

Test Engr: Jerry

Humidity (%): 55

Description	Frequency (MHz)	Spectrum Reading (dBuV)	Correction Factor (dB/m)	Emission Level (dBuV/m)	Limit (dBuV/m)	Equip. Setup VBW	Pass or Fail
Channel_00 (peak mode)	2402	48.77	35.48	84.25	---	3MHz	---
Channel_00 (average mode)	2402.1	48.05	35.48	83.53	---	1KHz	---
Channel_78 (peak mode)	2480.1	47.6	35.5	83.1	---	3MHz	---
Channel_78 (average mode)	2480.1	46.89	35.5	82.39	---	1KHz	---
Channel_00 Restricted band (peak mode)	2390	15.14	35.47	50.61	74	3MHz	Pass
Restricted band (average mode)	2390	5.3	35.47	40.77	54	1KHz	Pass
Channel_78 Restricted band (peak mode)	2483.5	16.41	35.51	51.92	74	3MHz	Pass
Restricted band (average mode)	2483.5	6.21	35.51	41.72	54	1KHz	Pass

Note:

- The Spectrum plot of emission level measurement in Restricted band is attached.
- Emission Level=Spectrum Reading+Correction Factor
- Correction Factor=Antenna Factor+cable loss–amplifier gain
- Both Horizontal and Vertical polarizaion have been tested and the worst data is listed above.

Restricted Band (Radiated)-Peak Mode (Channel 00)

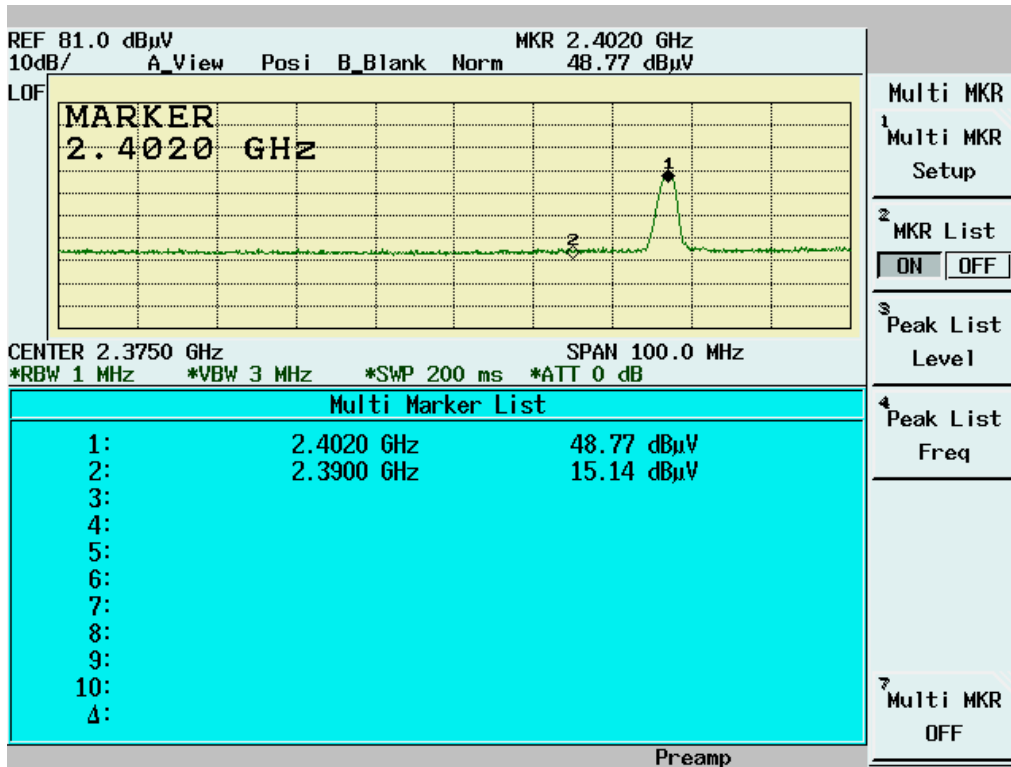

Restricted Band (Radiated)-Average Mode (Channel 00)

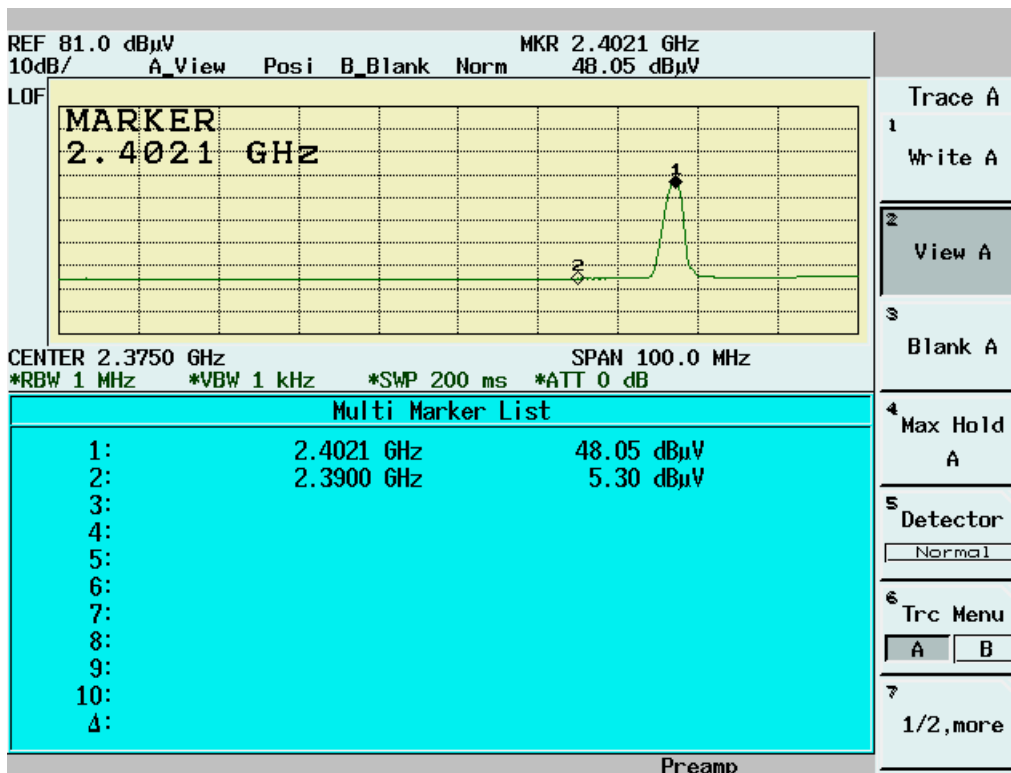

Restricted Band (Radiated)-Peak Mode (Channel 78)

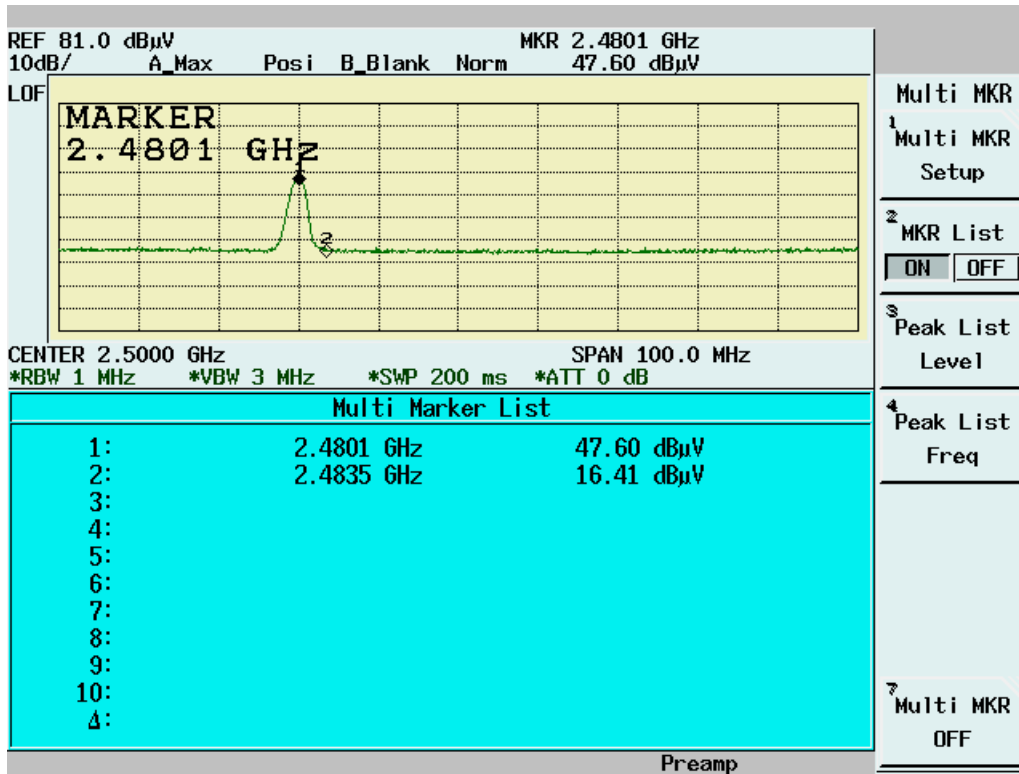

Restricted Band (Radiated)-Average Mode (Channel 78)

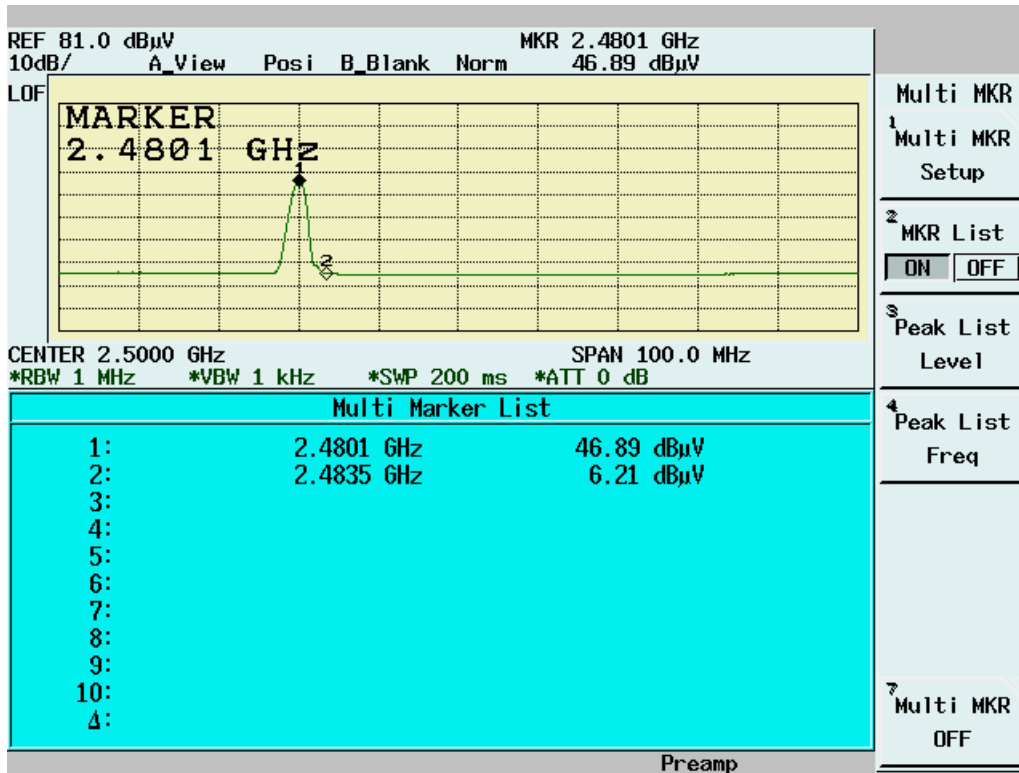

Test condition: Data Rate= 2Mbps, DH5

Table Restricted Bands measurement (Radiated)

Temp. (° C): 25

Test Engr: Jerry

Humidity (%): 55

Description	Frequency (MHz)	Spectrum Reading (dBuV)	Correction Factor (dB/m)	Emission Level (dBuV/m)	Limit (dBuV/m)	Equip. Setup VBW	Pass or Fail
Channel_00 (peak mode)	2401.8	55.27	35.48	90.75	---	3MHz	---
Channel_00 (average mode)	2402	51.37	35.48	86.85	---	1KHz	---
Channel_78 (peak mode)	2480	46.36	35.5	81.86	---	3MHz	---
Channel_78 (average mode)	2480	41.9	35.5	77.4	---	1KHz	---
Channel_00 Restricted band (peak mode)	2390	13.23	35.47	48.7	74	3MHz	Pass
Restricted band (average mode)	2390	2.53	35.47	38	54	1KHz	Pass
Channel_78 Restricted band (peak mode)	2483.5	15.86	35.51	51.37	74	3MHz	Pass
Restricted band (average mode)	2483.5	4.07	35.51	39.58	54	1KHz	Pass

Note:

- The Spectrum plot of emission level measurement in Restricted band is attached.
- Emission Level=Spectrum Reading+Correction Factor
- Correction Factor=Antenna Factor+cable loss–amplifier gain
- Both Horizontal and Vertical polarizaion have been tested and the worst data is listed above.

Restricted Band (Radiated)-Peak Mode (Channel 00)

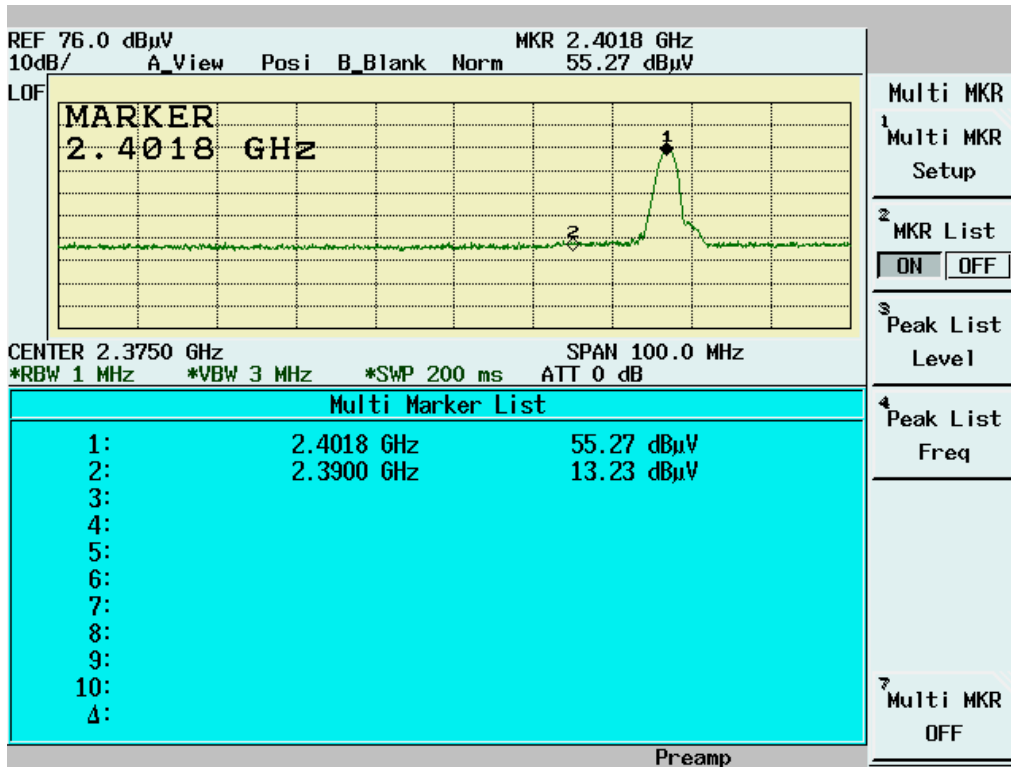

Restricted Band (Radiated)-Average Mode (Channel 00)

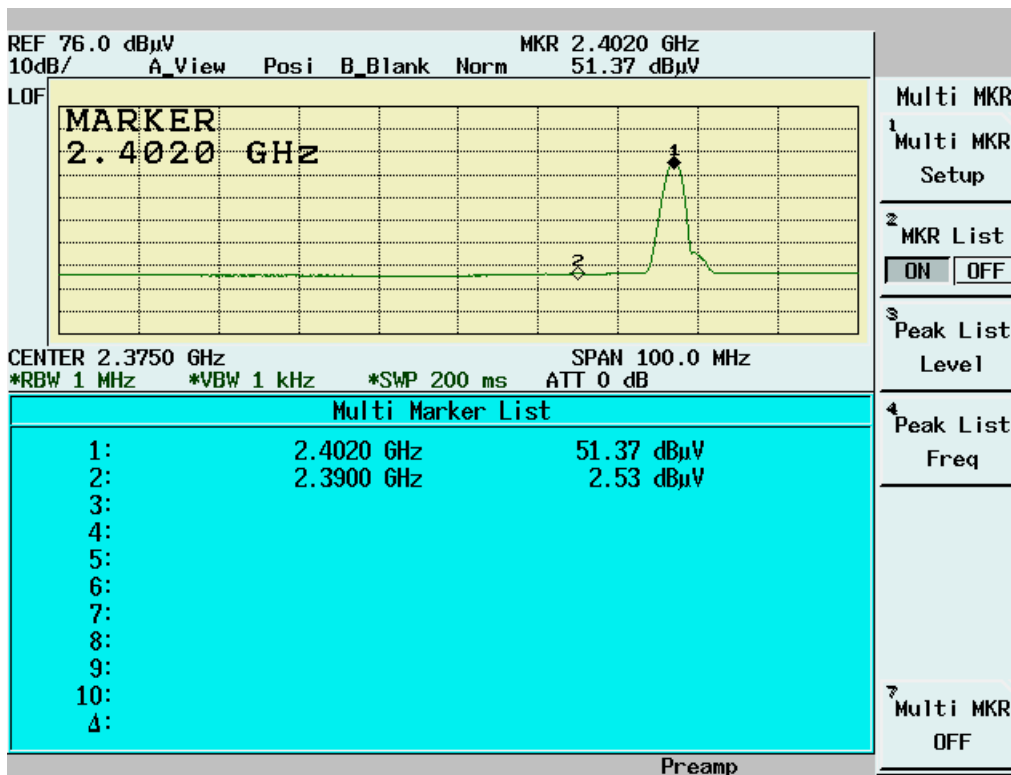

Restricted Band (Radiated)-Peak Mode (Channel 78)

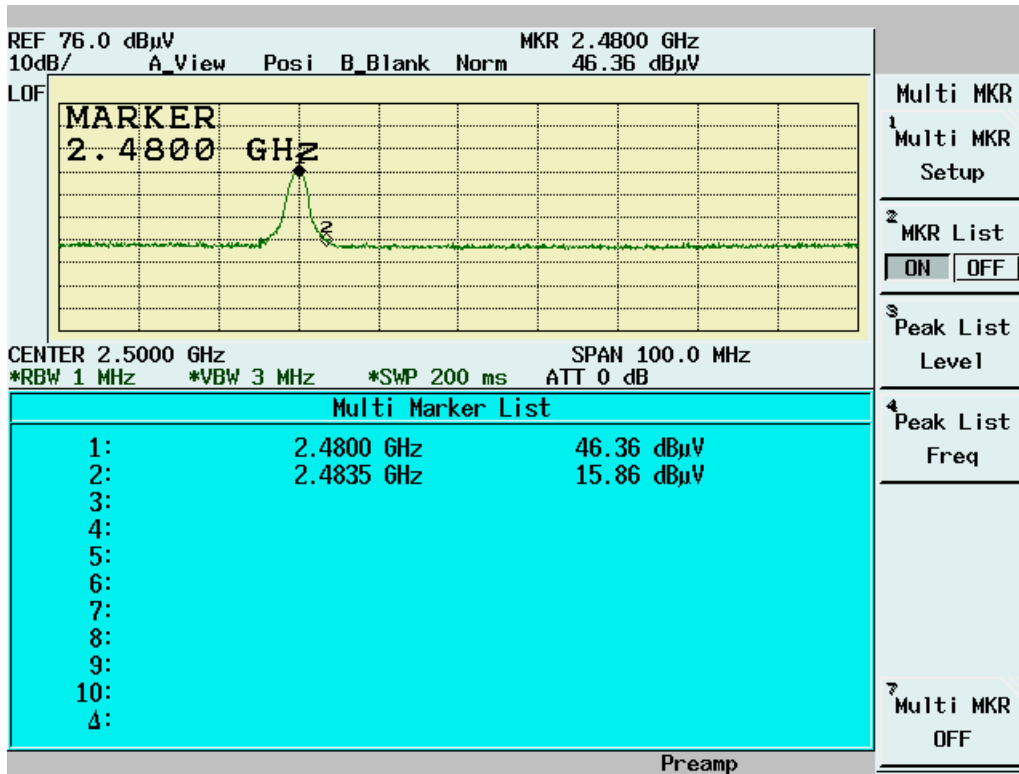

Restricted Band (Radiated)-Average Mode (Channel 78)

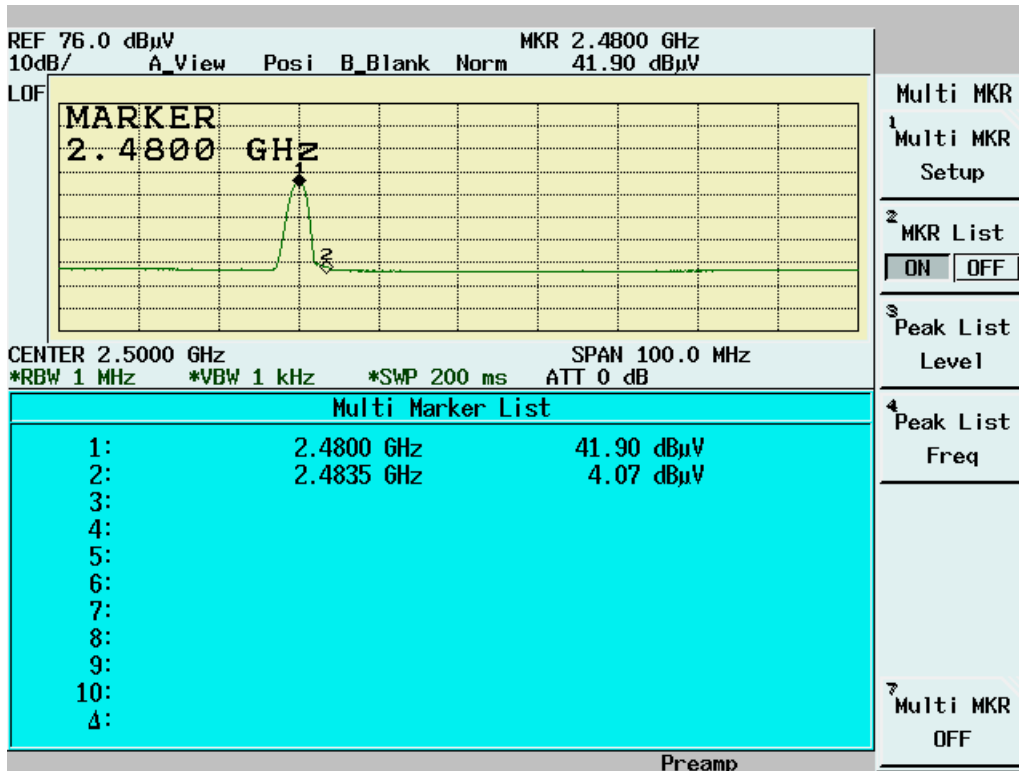

Test condition: Data Rate= 3MBps, DH5

Table Restricted Bands measurement (Radiated)

Temp. (° C): 25

Test Engr: Jerry

Humidity (%): 55

Description	Frequency (MHz)	Spectrum Reading (dBuV)	Correction Factor (dB/m)	Emission Level (dBuV/m)	Limit (dBuV/m)	Equip. Setup VBW	Pass or Fail
Channel_00 (peak mode)	2402	55.4	35.48	90.88	---	3MHz	---
Channel_00 (average mode)	2401.9	51.25	35.48	86.73	---	1KHz	---
Channel_78 (peak mode)	2480	46.45	35.5	81.95	---	3MHz	---
Channel_78 (average mode)	2480	41.81	35.5	77.31	---	1KHz	---
Channel_00 Restricted band (peak mode)	2390	13.2	35.47	48.67	74	3MHz	Pass
Restricted band (average mode)	2390	2.64	35.47	38.11	54	1KHz	Pass
Channel_78 Restricted band (peak mode)	2483.5	16.32	35.51	51.83	74	3MHz	Pass
Restricted band (average mode)	2483.5	3.92	35.51	39.43	54	1KHz	Pass

Note:

- The Spectrum plot of emission level measurement in Restricted band is attached.
- Emission Level=Spectrum Reading+Correction Factor
- Correction Factor=Antenna Factor+cable loss–amplifier gain
- Both Horizontal and Vertical polarizaion have been tested and the worst data is listed above.

Restricted Band (Radiated)-Peak Mode (Channel 00)

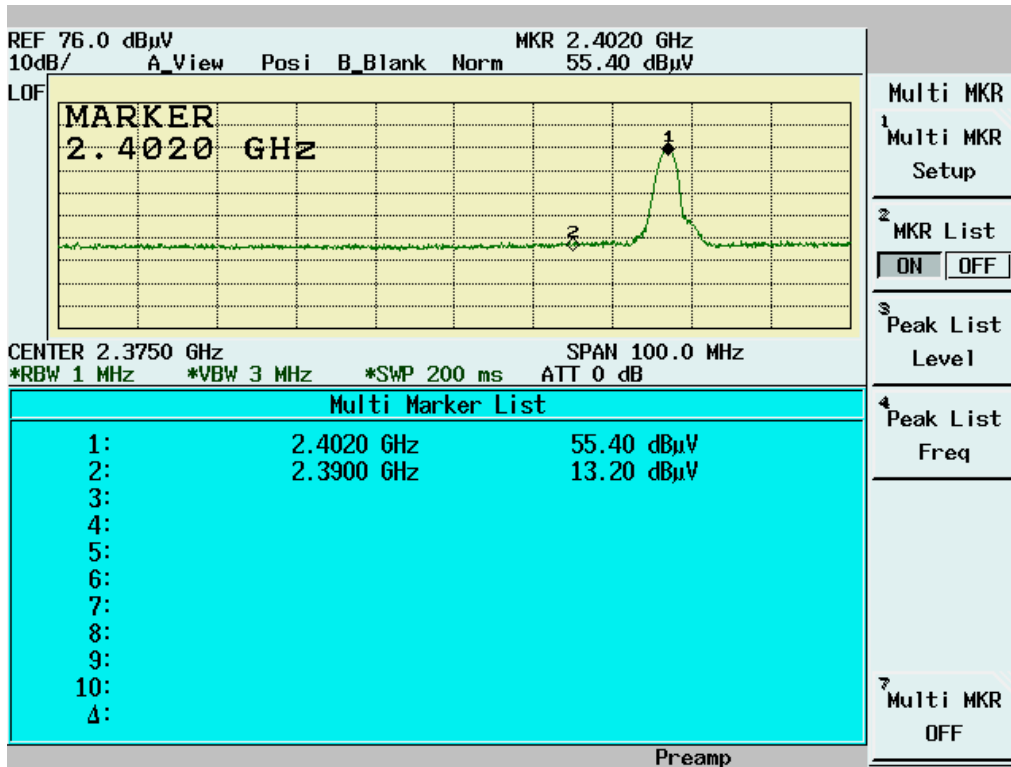

Restricted Band (Radiated)-Average Mode (Channel 00)

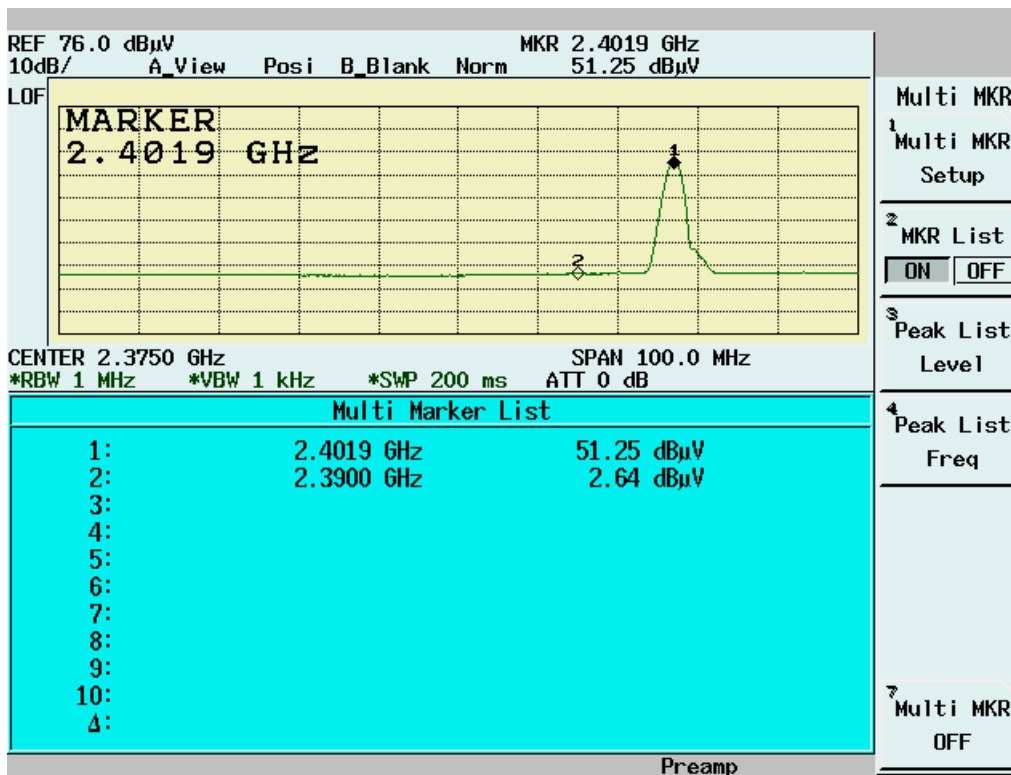

Restricted Band (Radiated)-Peak Mode (Channel 78)

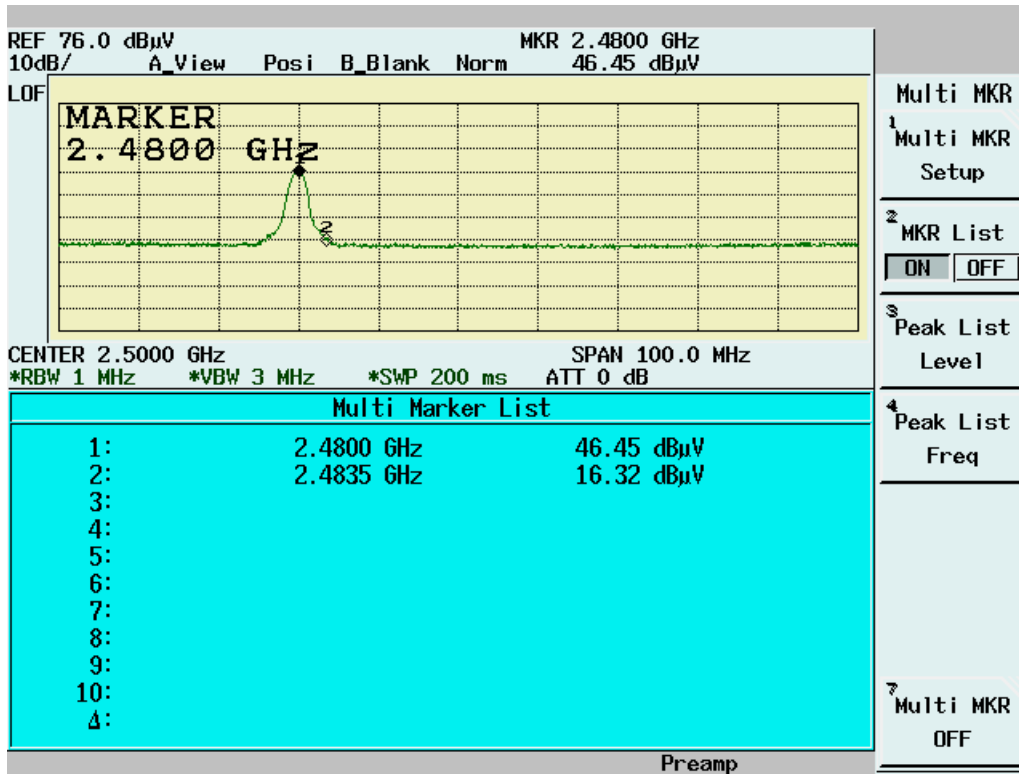

Restricted Band (Radiated)-Average Mode (Channel 78)

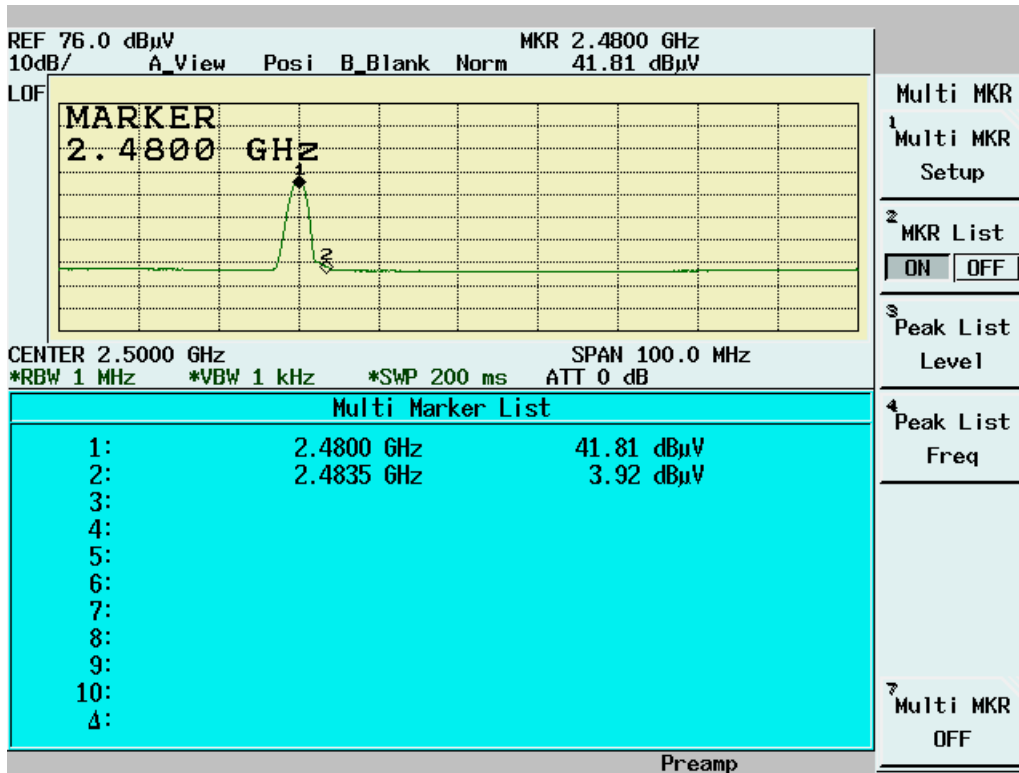

4.6 Bandwidth & Hopping Channel Separation

4.6.1 Standard Applicable

According to §15.247(a)(1), frequency hopping system shall have, hopping channel carrier frequencies separated by a minimum of 25 kHz or the 20 dB bandwidth of the hopping channel, whichever is greater. The system shall hop to channel frequencies that are selected at the system hopping rate from a pseudo randomly ordered list of hopping frequencies.

4.6.2 Test Procedure

■ Bandwidth Test Procedure

The Transmitter output of EUT was connected to the spectrum analyzer. The 20 dB bandwidth of the fundamental frequency was measured. The setting of spectrum analyzer is as follows

Equipment mode	Spectrum analyzer
Detector function	Peak mode
RBW	30KHz ($\geq 1\%$ of the 20 dB bandwidth)
VBW	100KHz

■ Hopping Channel Separation Test Procedure

1. Connect EUT antenna terminal to the spectrum analyzer with a low loss cable.
Equipment mode: Spectrum analyzer
RBW: 100KHz
VBW: 300KHz
SPAN:3MHz
2. By using the Max-Hold function record the separation of two adjacent channels.
3. Measure the frequency difference of these two adjacent channels by spectrum analyzer Marker function.
4. Repeat above procedures until all frequencies measured were complete.

4.6.3 Test Setup

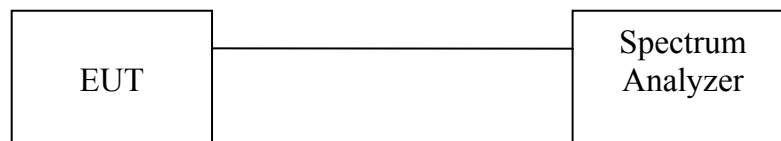

4.6.4 Test Data

Test condition: Data Rate= 1MBps, DH5

20dB Bandwidth

Tem. (°C):25

Test Engineer: Jerry Chiou

Hum. (%):55

Channel	Frequency (MHz)	20dB Bandwidth (KHz)
00	2402	884
39	2441	876
78	2480	884

Hopping Channel Separation

Temperature (°C):25

Test Engineer: Jerry Chiou

Humidity (%):55

Channel	Frequency (MHz)	Separation (KHz)	Limit (KHz)	Pass/Fail
00	2402	1002	≥ 884	Pass
39	2441	1008	≥ 876	Pass
78	2480	1008	≥ 884	Pass

20dB Bandwidth Channel 00:



20dB Bandwidth Channel 39:

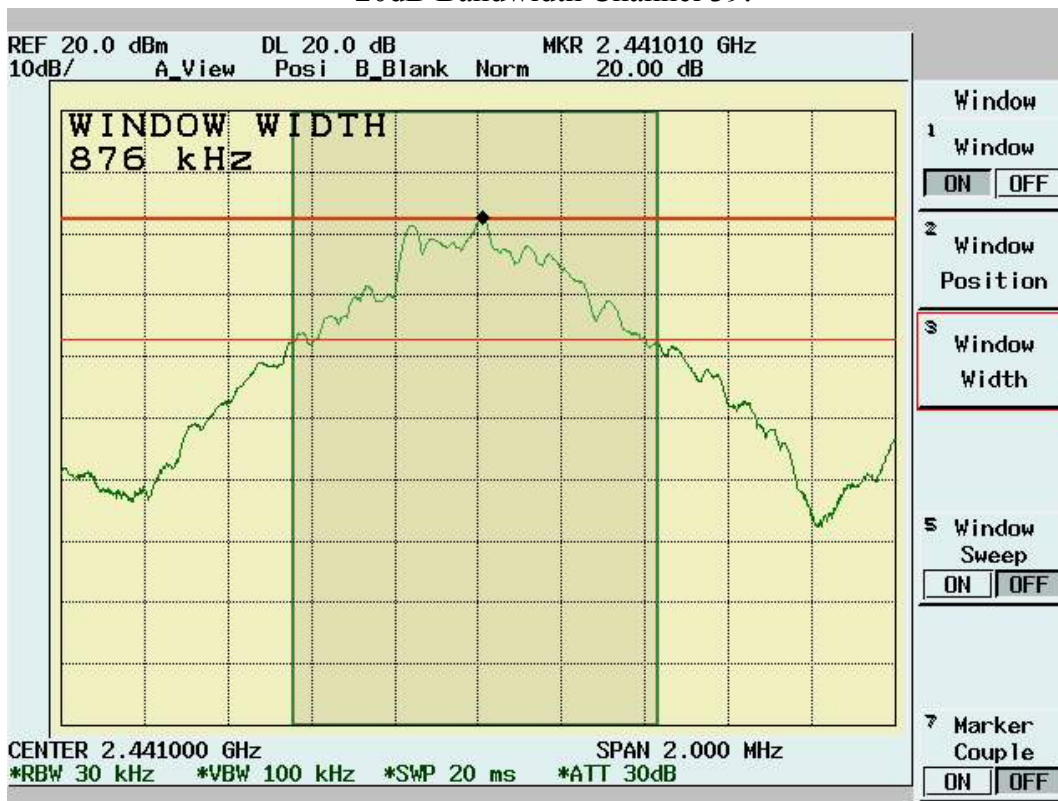

20dB Bandwidth Channel 78:

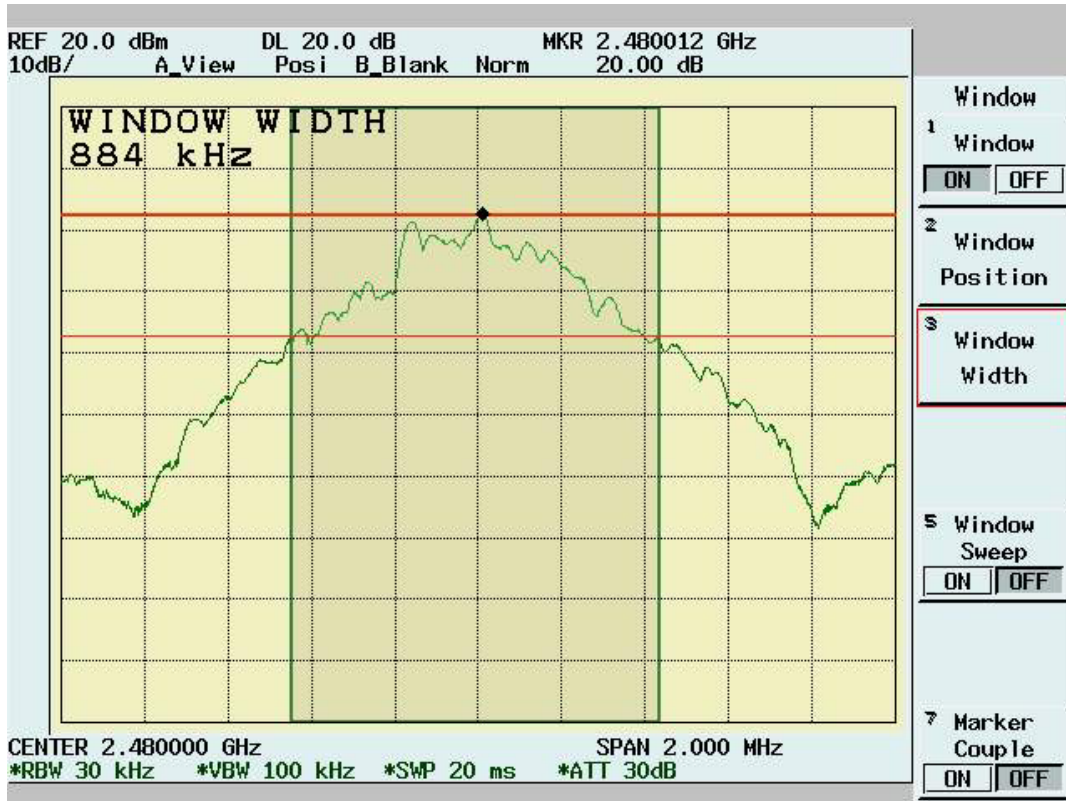

Hopping Channel Separation Channel 00



Hopping Channel Separation Channel 39



Hopping Channel Separation Channel 78



Test condition: Data Rate= 2Mbps, DH5

20dB Bandwidth

Tem. (°C):25

Test Engineer: Jerry Chiou

Hum. (%):55

Channel	Frequency (MHz)	20dB Bandwidth (KHz)
00	2402	1212
39	2441	1216
78	2480	1216

20dB Bandwidth Channel 00:

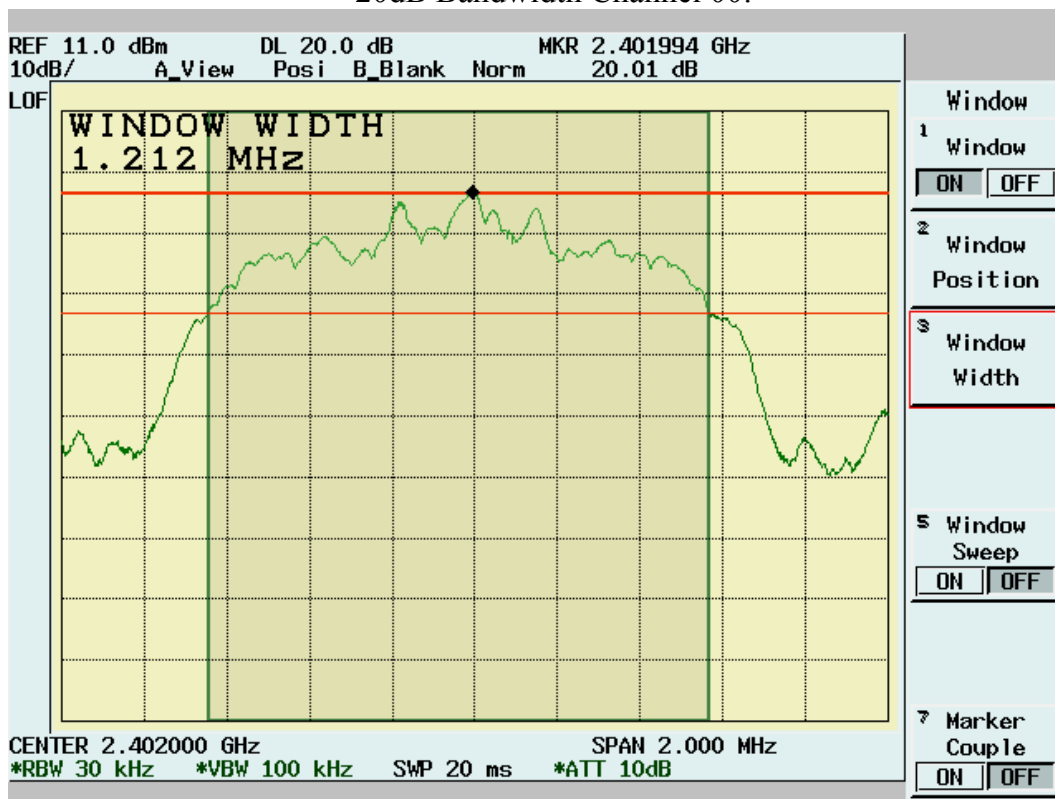

20dB Bandwidth Channel 39:

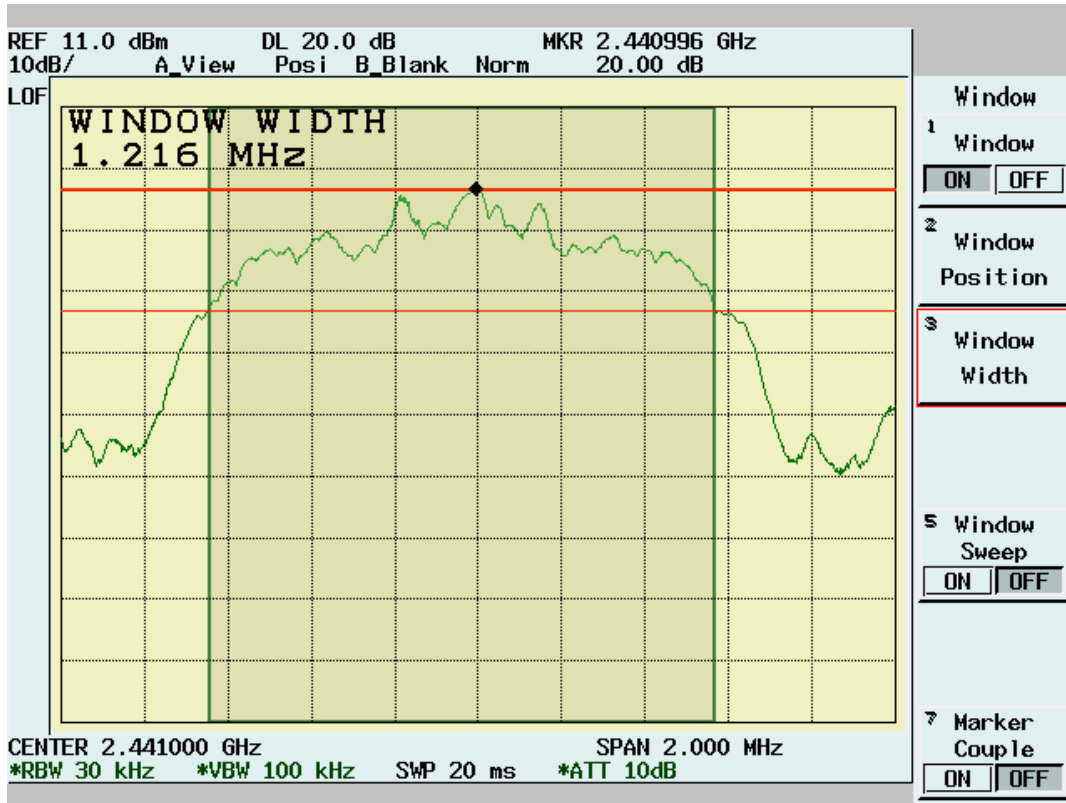

20dB Bandwidth Channel 78:

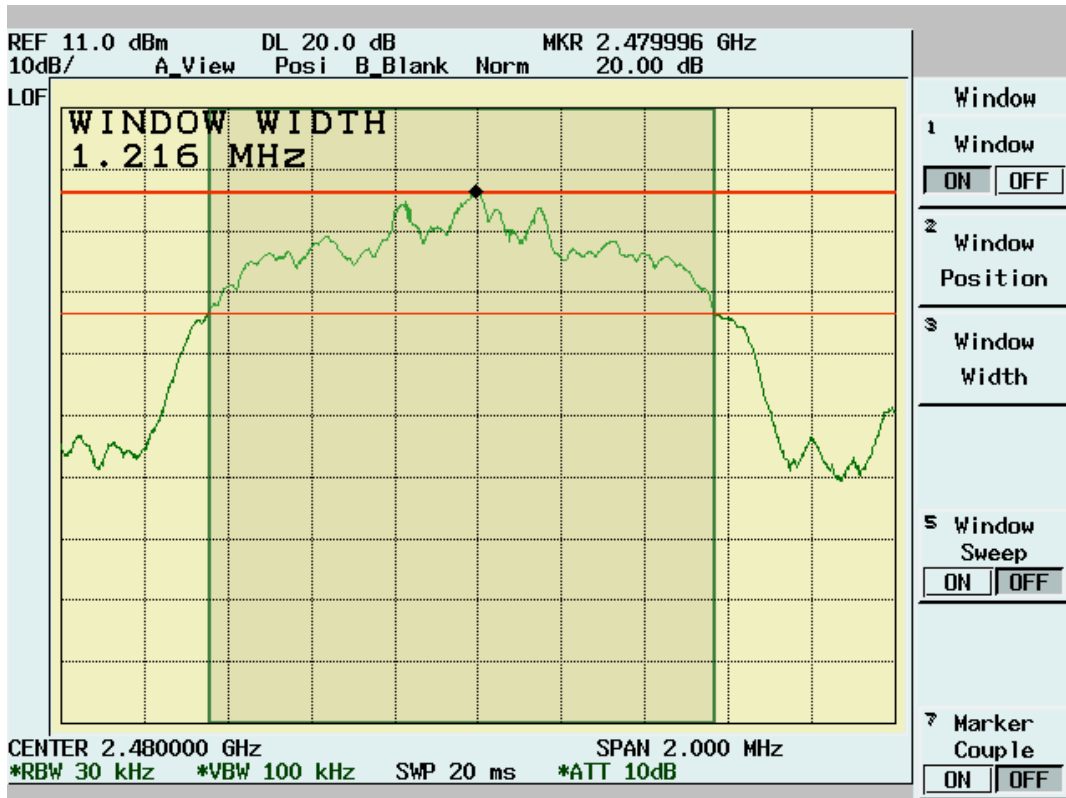

Test condition: Data Rate= 3Mbps, DH5

20dB Bandwidth

Tem. (°C):25

Test Engineer: Jerry Chiou

Hum. (%):55

Channel	Frequency (MHz)	20dB Bandwidth (KHz)
00	2402	1268
39	2441	1268
78	2480	1264

20dB Bandwidth Channel 00:

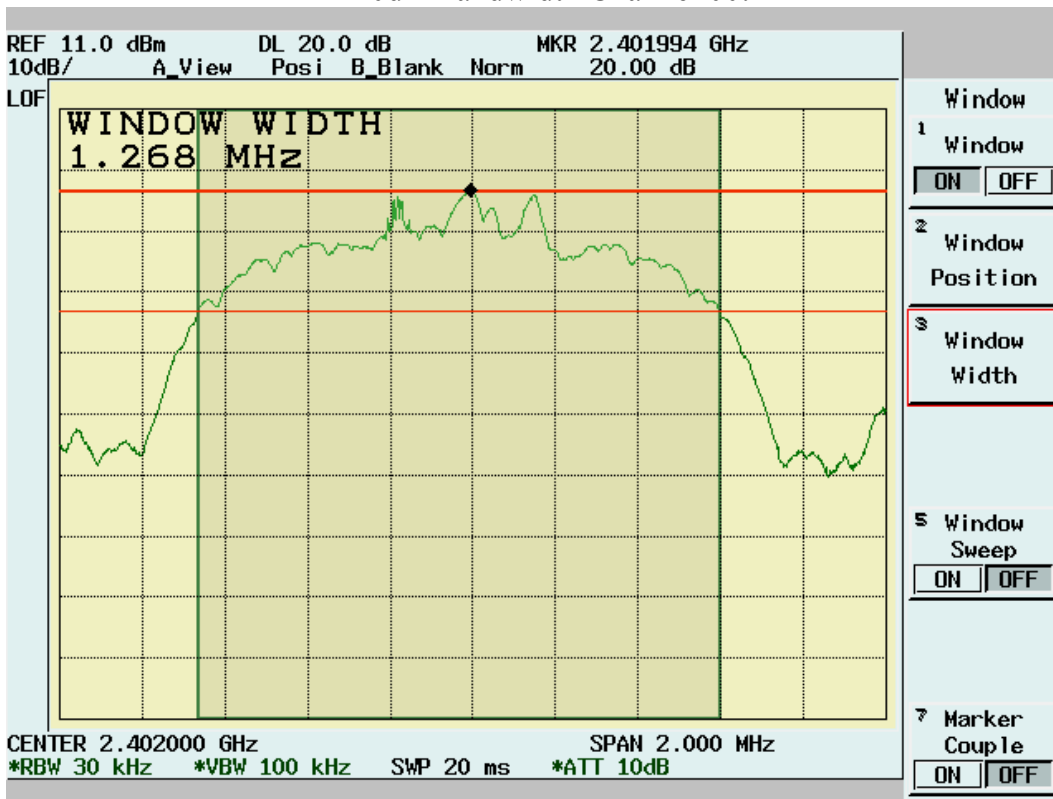

20dB Bandwidth Channel 39:

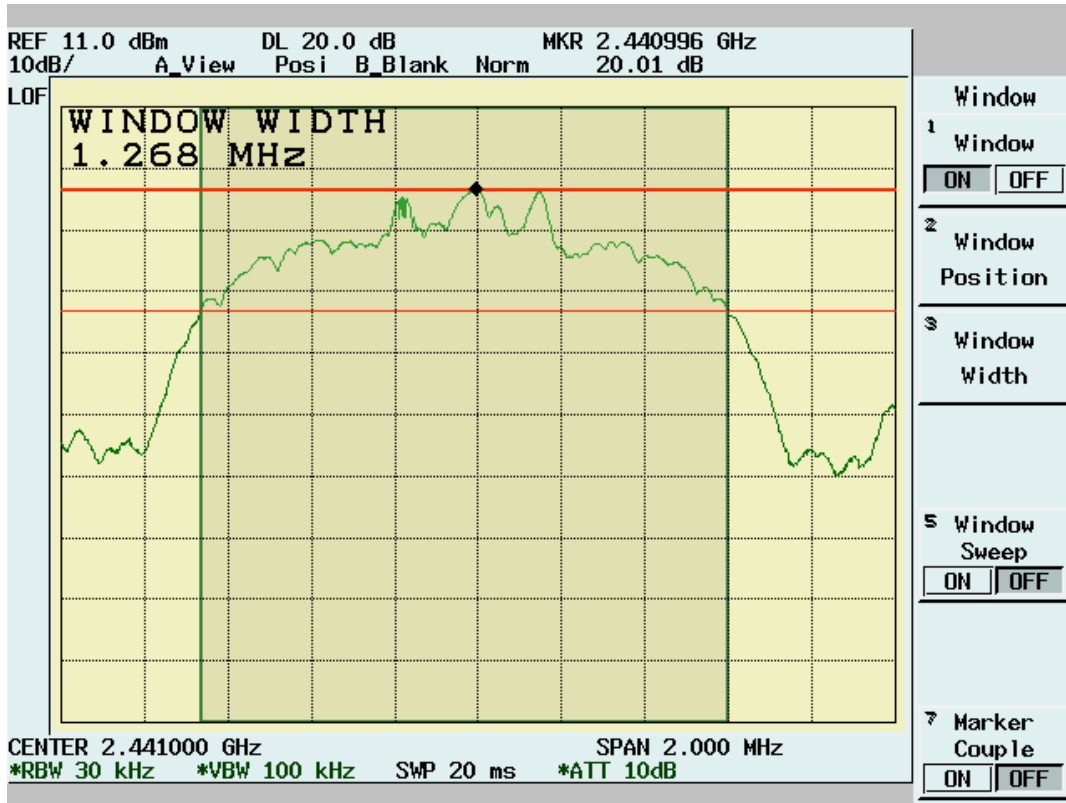

20dB Bandwidth Channel 78:

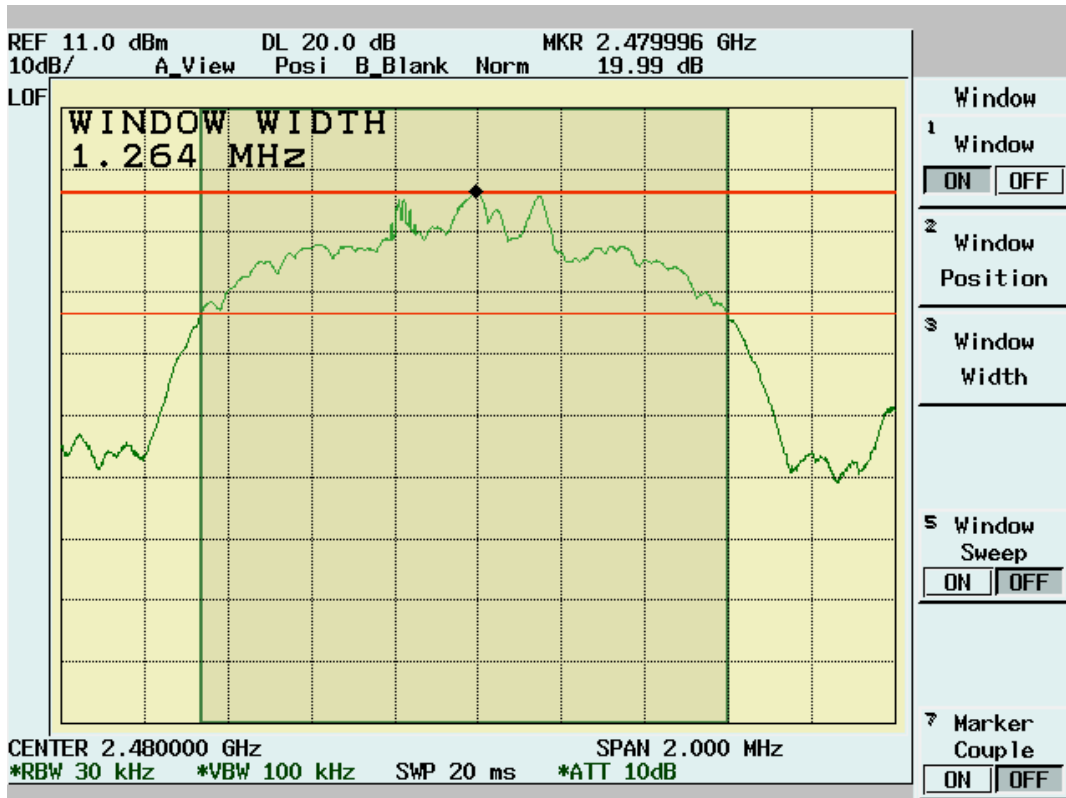

4.7 Number of Hopping Frequency Used

4.7.1 Test Procedure

1. Connect EUT antenna terminal to the spectrum analyzer with a low loss cable.
Equipment mode: Spectrum analyzer
RBW: 300KHz
VBW: 1MHz
2. Set the spectrum analyzer on Max-Hold Mode, and then keep the EUT in hopping mode. Record all the signals from each channel until each one has been recorded.
3. Repeat above procedures until all frequencies measured were complete.

4.7.2 Test Setup

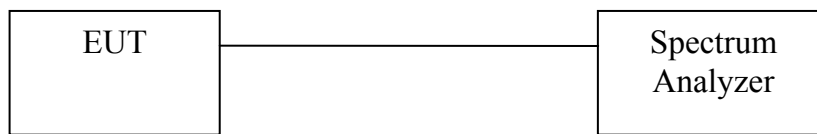

4.7.3 Test Data

Number of Hopping Frequency Used

Temperature (°C):25

Humidity (%):55

Test Engineer:Jerry Chiou

Test result	Limit (Channels)	Pass/Fail
79	>75	Pass

2400~2405MHz

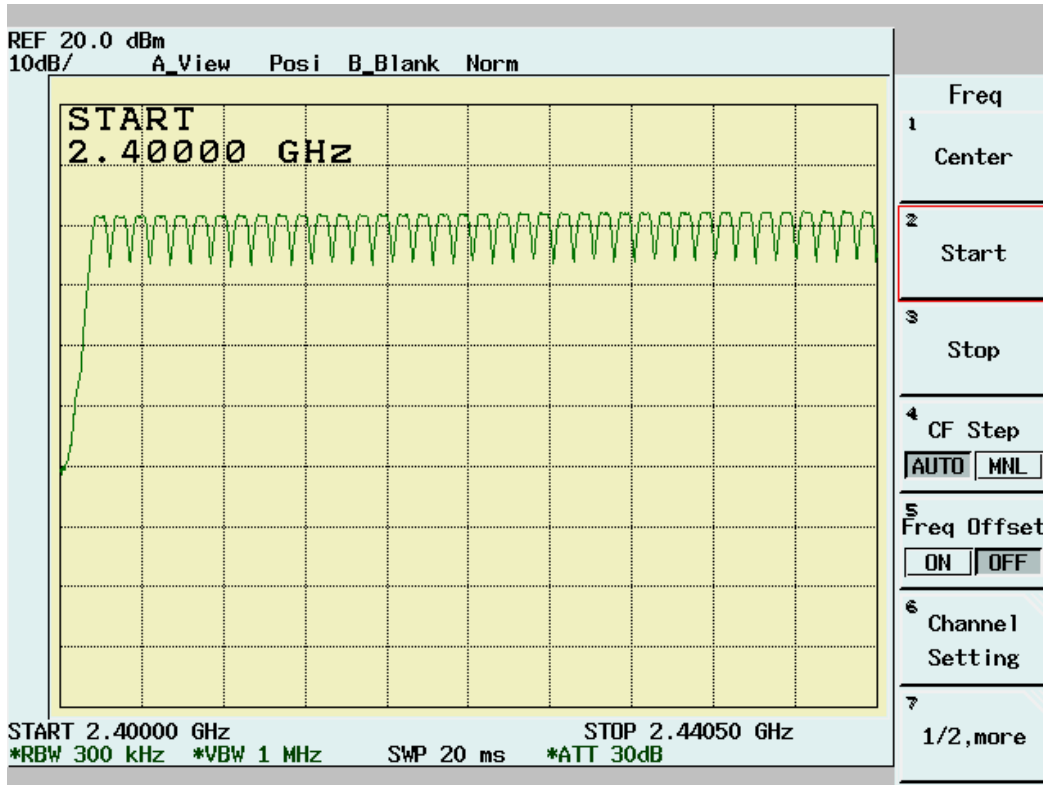

2405~2482MHz

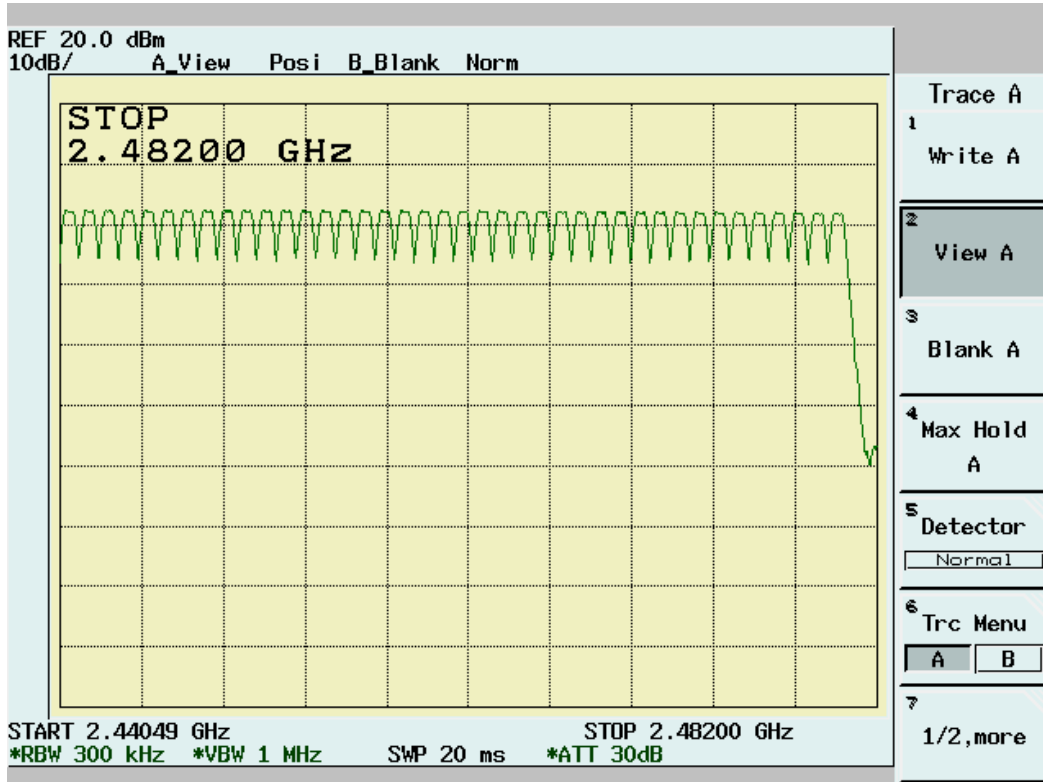

4.8 Dwell Time

4.8.1 Test Procedure

1. Connect EUT antenna terminal to the spectrum analyzer with a low loss cable.
Equipment mode: Spectrum analyzer
RBW: 1MHz
VBW: 1MHz
SPAN: Zero Span
2. Adjust the center frequency of spectrum analyzer on any frequency be measured.
3. Measure the Dwell Time by spectrum analyzer Marker function.
4. Repeat above procedures until all frequencies measured were complete.

4.8.2 Test Setup

Condition 1:



Condition 2:

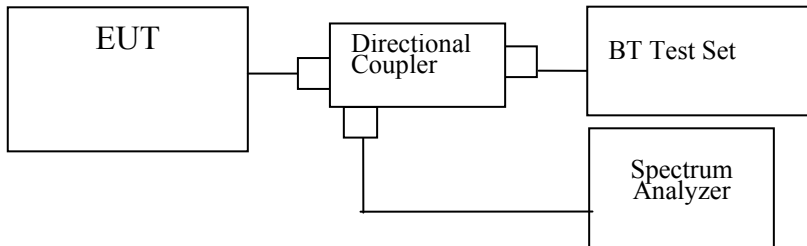

4.8.3 Test Data

Test condition: Data Rate= 1MBps

Dwell Time

Temperature (°C):25

Humidity (%):55

Test Engineer:Jerry Chiou

Mode	Frequency (MHz)	Spectrum	Test	Limit (ms)		Pass/Fail
		Reading (µs)	Result (ms)			
DH1	2402	414	264.96	<	400	Pass
DH3	2402	1660	354.13	<	400	Pass
DH5	2402	2904	371.71	<	400	Pass

Mode	Frequency (MHz)	Spectrum	Test	Limit (ms)		Pass/Fail
		Reading (µs)	Result (ms)			
DH1	2441	416	266.24	<	400	Pass
DH3	2441	1668	355.84	<	400	Pass
DH5	2441	2912	372.74	<	400	Pass

Mode	Frequency (MHz)	Spectrum	Test	Limit (ms)		Pass/Fail
		Reading (µs)	Result (ms)			
DH1	2480	414	264.96	<	400	Pass
DH3	2480	1664	354.99	<	400	Pass
DH5	2480	2920	373.76	<	400	Pass

Note:

A period time=79x0.4(s)=31.6(s)

CH00	DH1 time slot=	$414 \frac{(\mu s) * (1600 / (1 * 79)) * 31.6}{=}$	264.96 (ms)
	DH3 time slot=	$1660 \frac{(\mu s) * (1600 / (3 * 79)) * 31.6}{=}$	354.13 (ms)
	DH5 time slot=	$2904 \frac{(\mu s) * (1600 / (5 * 79)) * 31.6}{=}$	371.71 (ms)
CH39	DH1 time slot=	$416 \frac{(\mu s) * (1600 / (1 * 79)) * 31.6}{=}$	266.24 (ms)
	DH3 time slot=	$1668 \frac{(\mu s) * (1600 / (3 * 79)) * 31.6}{=}$	355.84 (ms)
	DH5 time slot=	$2912 \frac{(\mu s) * (1600 / (5 * 79)) * 31.6}{=}$	372.74 (ms)
CH78	DH1 time slot=	$414 \frac{(\mu s) * (1600 / (1 * 79)) * 31.6}{=}$	264.96 (ms)
	DH3 time slot=	$1664 \frac{(\mu s) * (1600 / (3 * 79)) * 31.6}{=}$	354.99 (ms)
	DH5 time slot=	$2920 \frac{(\mu s) * (1600 / (5 * 79)) * 31.6}{=}$	373.76 (ms)

Channel 00 DH1:

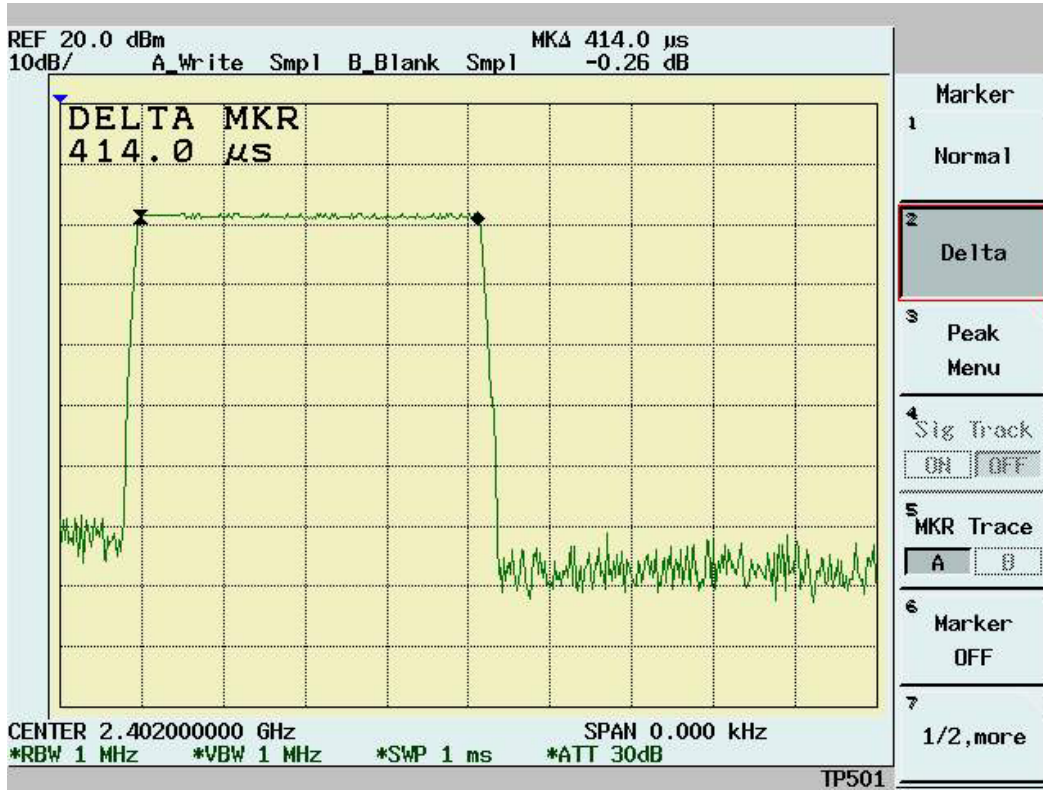

Channel 00 DH3:

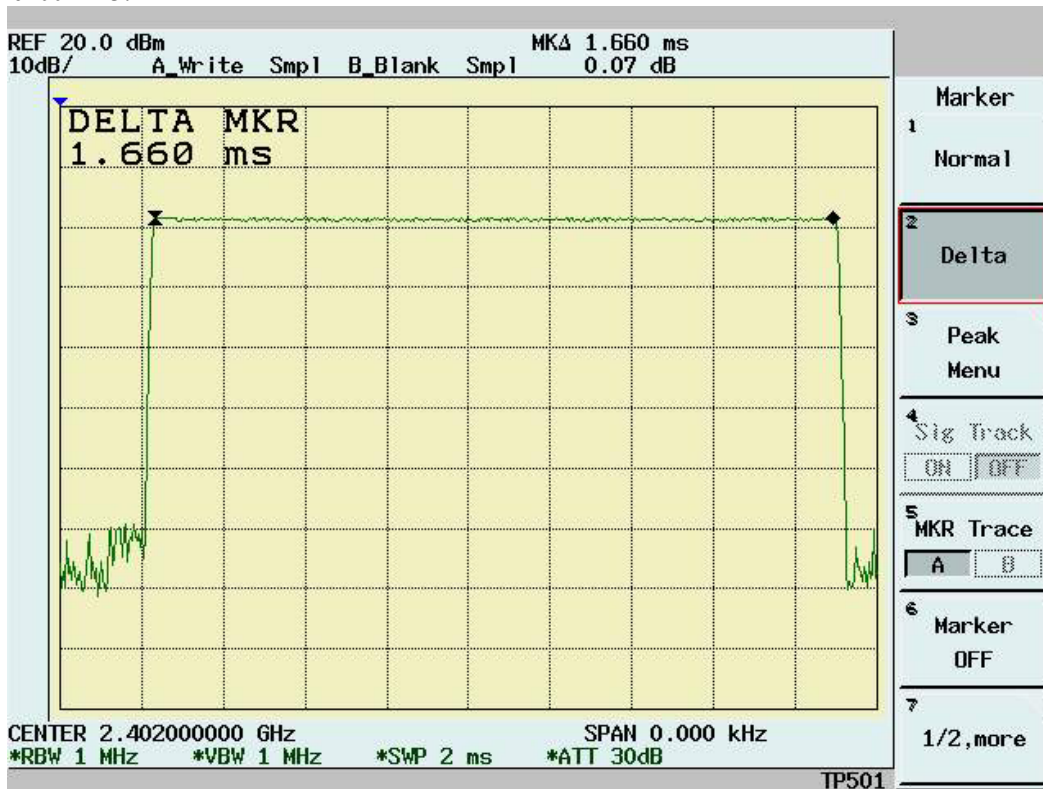

Channel 00 DH5:

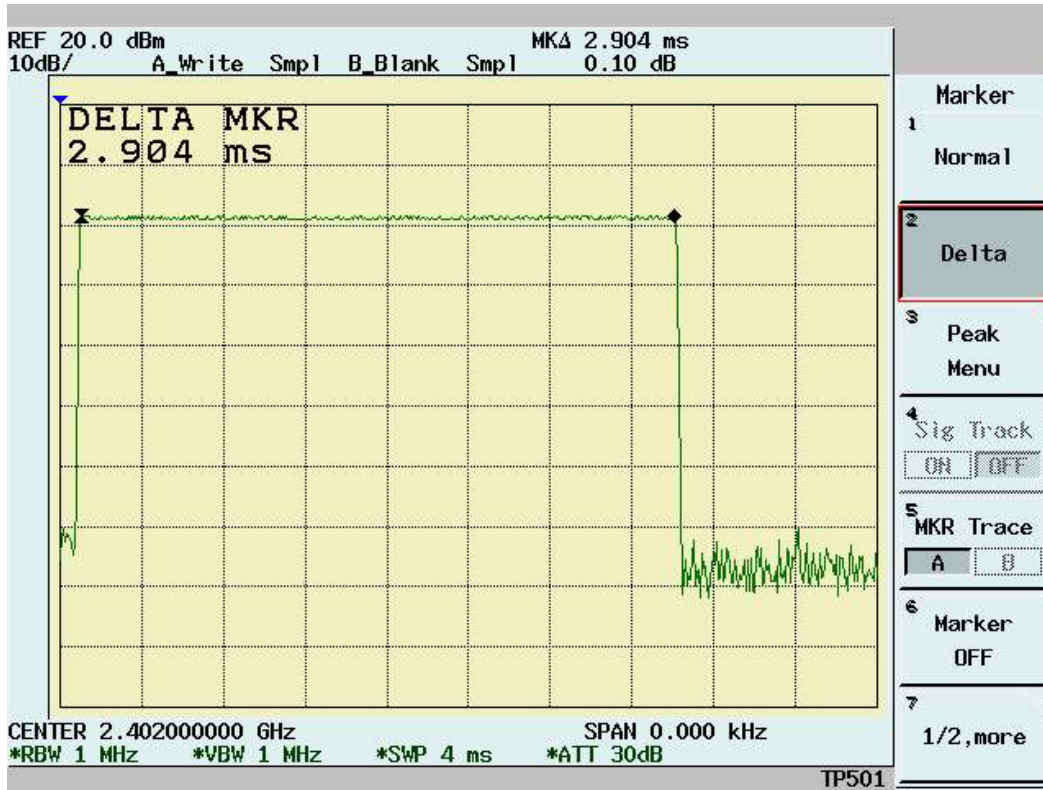

Channel 39 DH1:

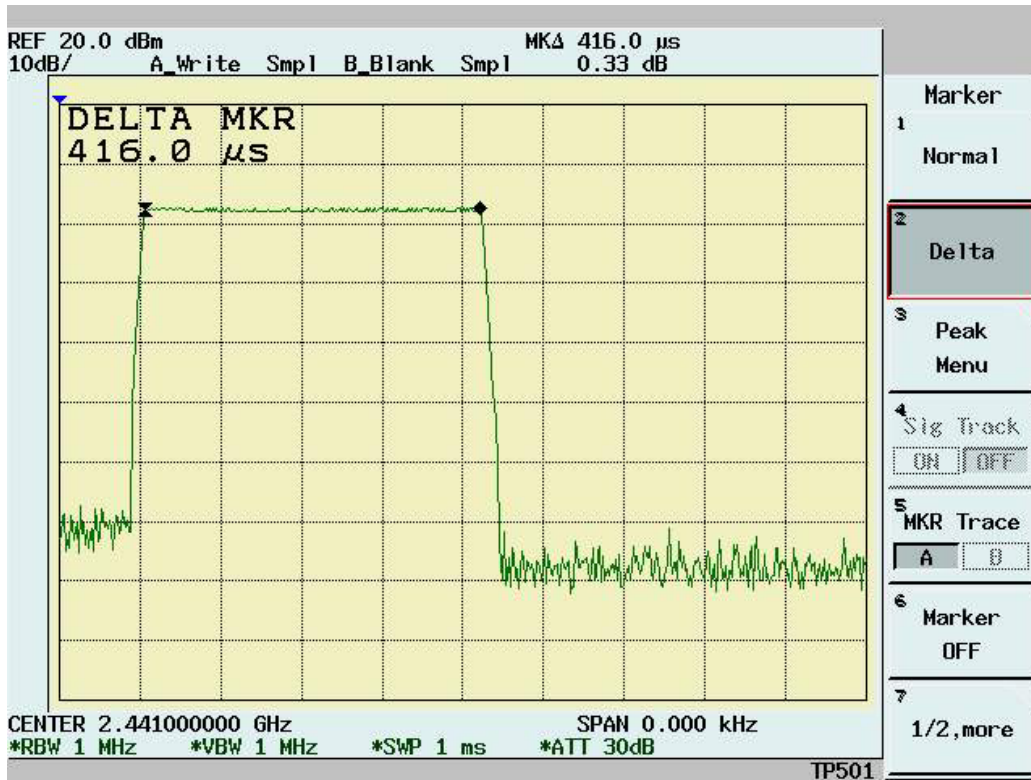

Channel 39 DH3:



Channel 39 DH5:

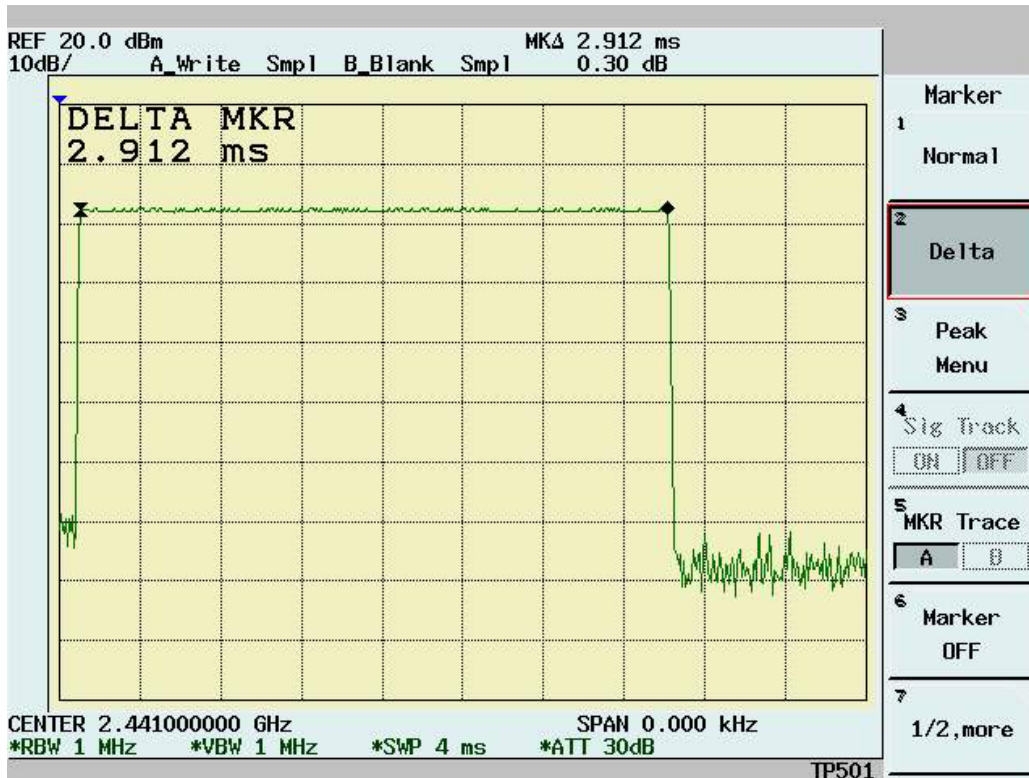

Channel 78 DH1:

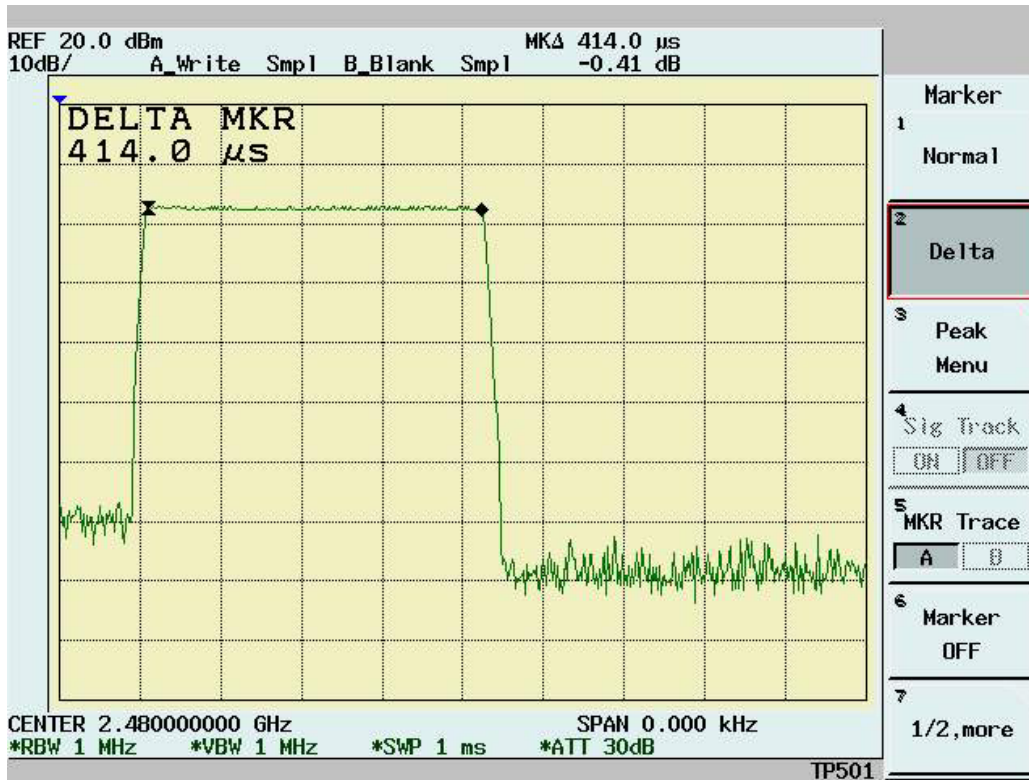

Channel 78 DH3:



Channel 78 DH5:

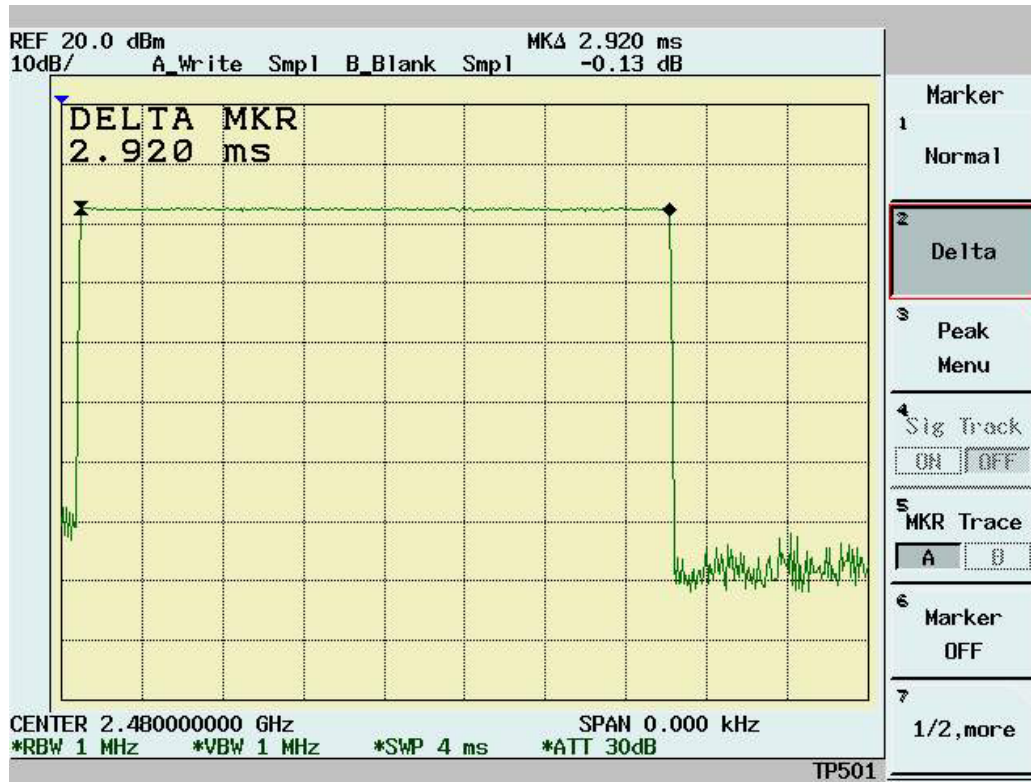

Test condition: Data Rate= 2MBps

Dwell Time

Temperature (°C):25

Test Engineer:Jerry Chiou

Humidity (%):55

Mode	Frequency (MHz)	Spectrum	Test	Limit (ms)	Pass/Fail
		Reading (µs)	Result (ms)		
DH1	2402	406	259.84	< 400	Pass
DH3	2402	1660	354.13	< 400	Pass
DH5	2402	2904	371.71	< 400	Pass

Mode	Frequency (MHz)	Spectrum	Test	Limit (ms)	Pass/Fail
		Reading (µs)	Result (ms)		
DH1	2441	408	261.12	< 400	Pass
DH3	2441	1656	353.28	< 400	Pass
DH5	2441	2888	369.66	< 400	Pass

Mode	Frequency (MHz)	Spectrum	Test	Limit (ms)	Pass/Fail
		Reading (µs)	Result (ms)		
DH1	2480	406	259.84	< 400	Pass
DH3	2480	1660	354.13	< 400	Pass
DH5	2480	2904	371.71	< 400	Pass

Note:

A period time=79x0.4(s)=31.6(s)

CH00	DH1 time slot=	$406 \frac{(\mu s) * (1600 / (1 * 79)) * 31.6}{=}$	259.84 (ms)
	DH3 time slot=	$1660 \frac{(\mu s) * (1600 / (3 * 79)) * 31.6}{=}$	354.13 (ms)
	DH5 time slot=	$2904 \frac{(\mu s) * (1600 / (5 * 79)) * 31.6}{=}$	371.71 (ms)
CH39	DH1 time slot=	$408 \frac{(\mu s) * (1600 / (1 * 79)) * 31.6}{=}$	261.12 (ms)
	DH3 time slot=	$1656 \frac{(\mu s) * (1600 / (3 * 79)) * 31.6}{=}$	353.28 (ms)
	DH5 time slot=	$2888 \frac{(\mu s) * (1600 / (5 * 79)) * 31.6}{=}$	369.66 (ms)
CH78	DH1 time slot=	$406 \frac{(\mu s) * (1600 / (1 * 79)) * 31.6}{=}$	259.84 (ms)
	DH3 time slot=	$1660 \frac{(\mu s) * (1600 / (3 * 79)) * 31.6}{=}$	354.13 (ms)
	DH5 time slot=	$2904 \frac{(\mu s) * (1600 / (5 * 79)) * 31.6}{=}$	371.71 (ms)

Channel 00 DH1:

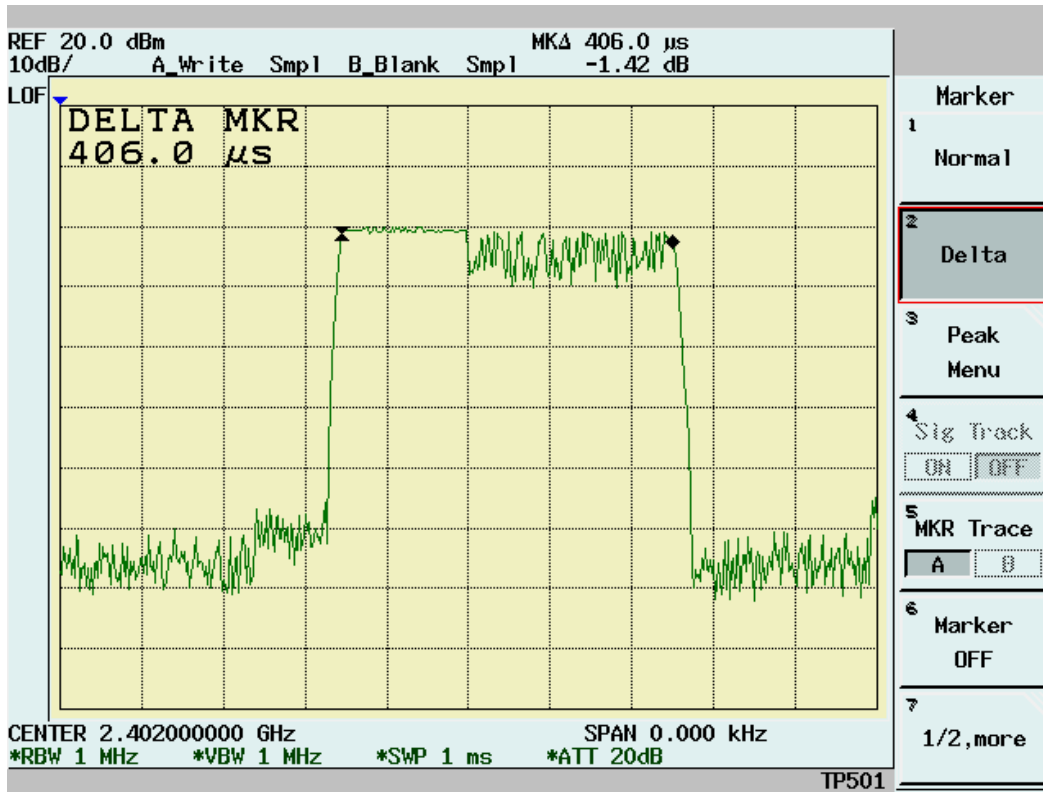

Channel 00 DH3:

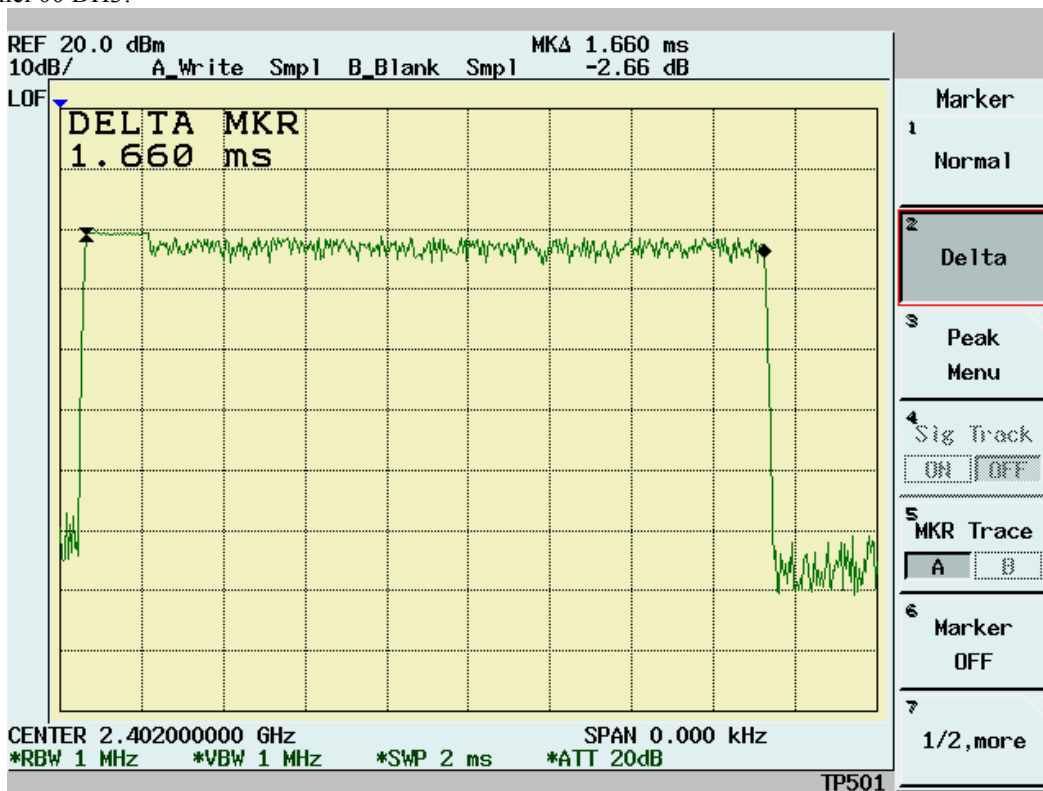

Channel 00 DH5:

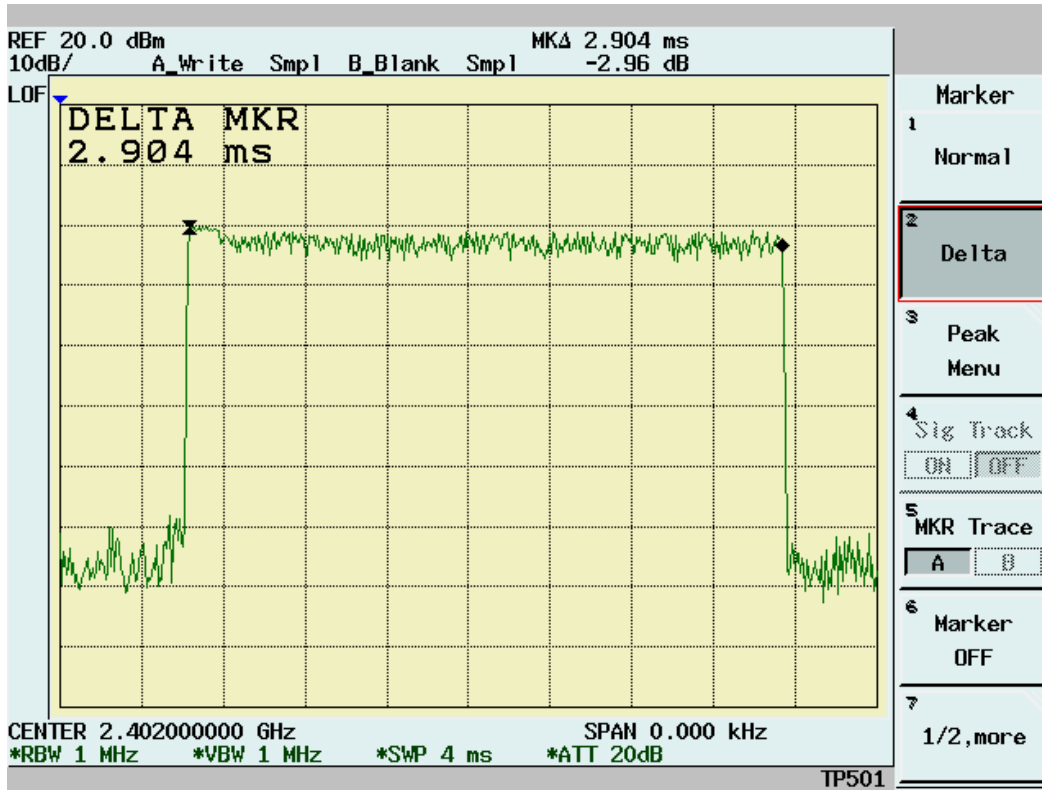

Channel 39 DH1:

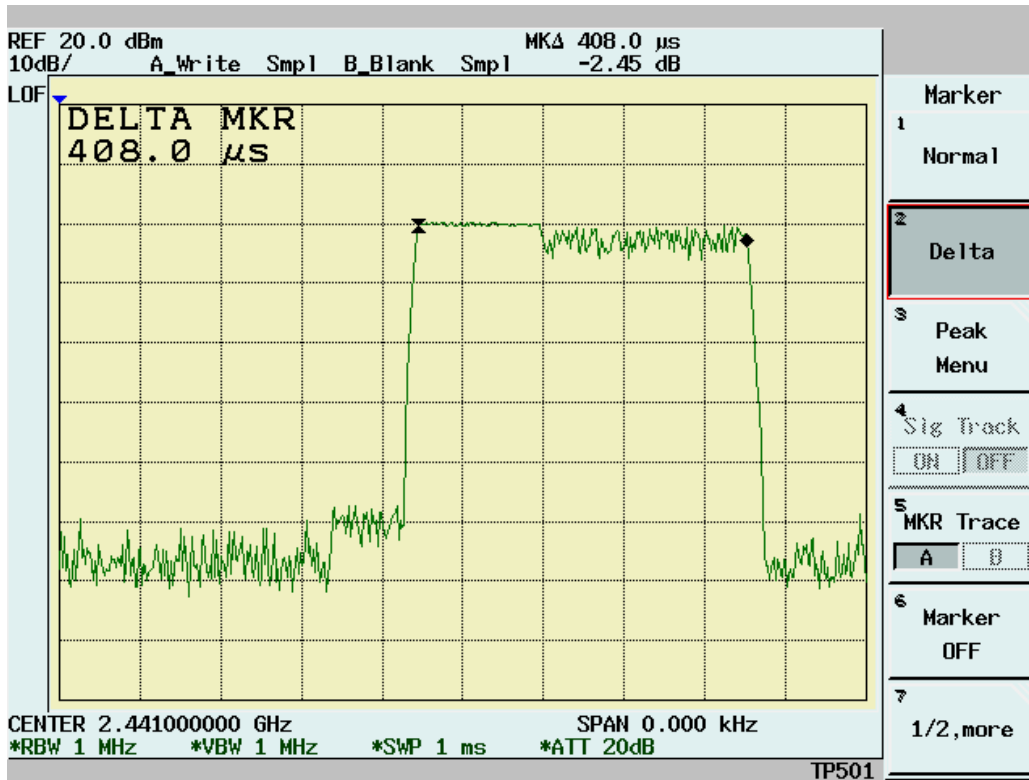

Channel 39 DH3:

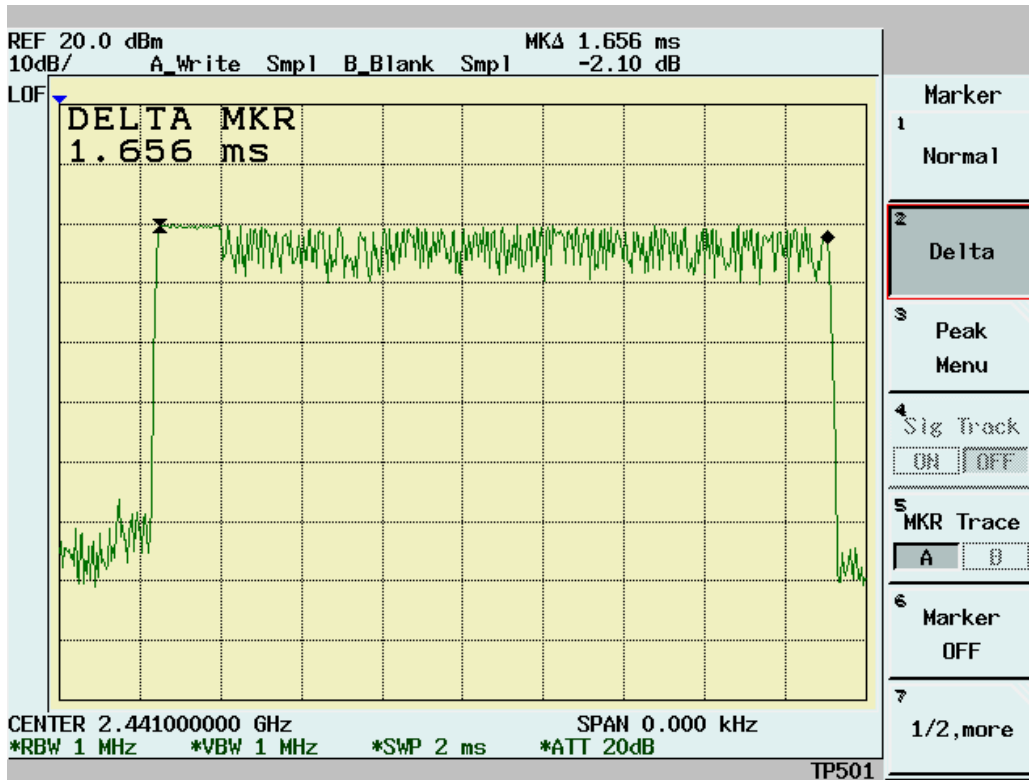

Channel 39 DH5:

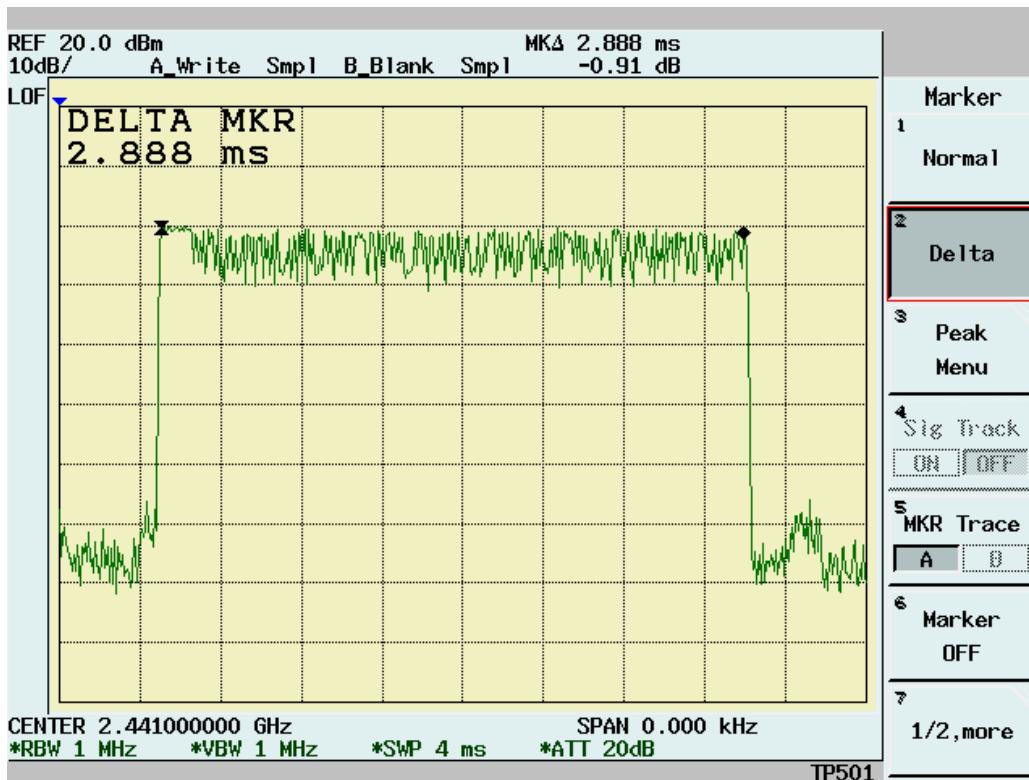

Channel 78 DH1:

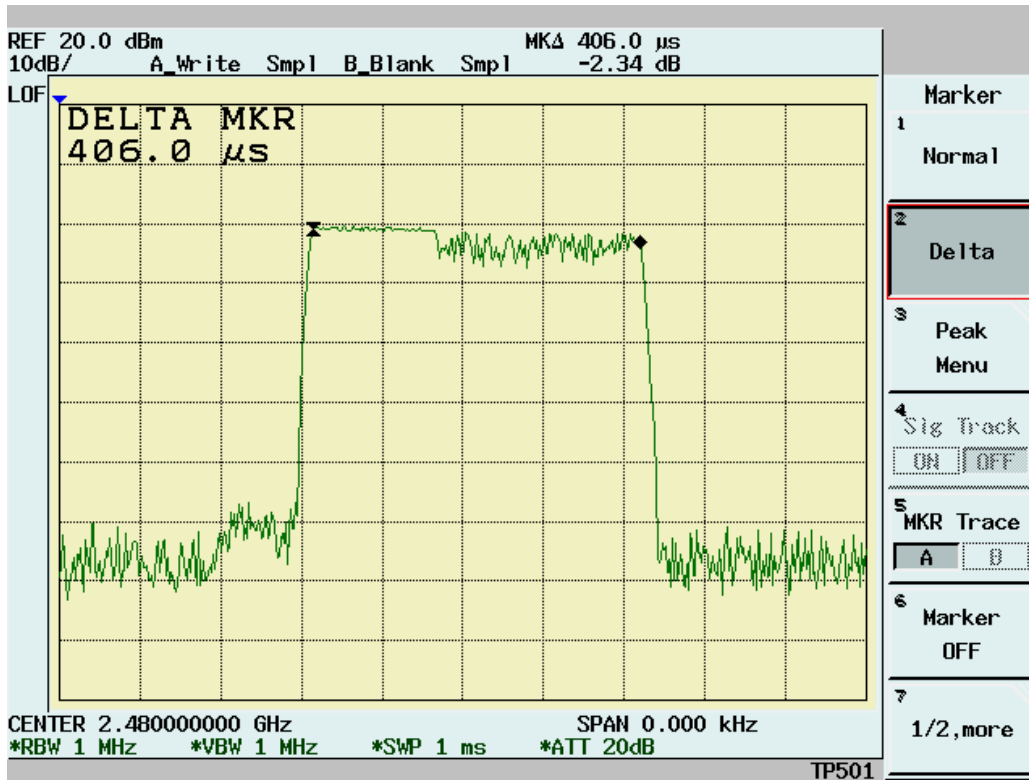

Channel 78 DH3:

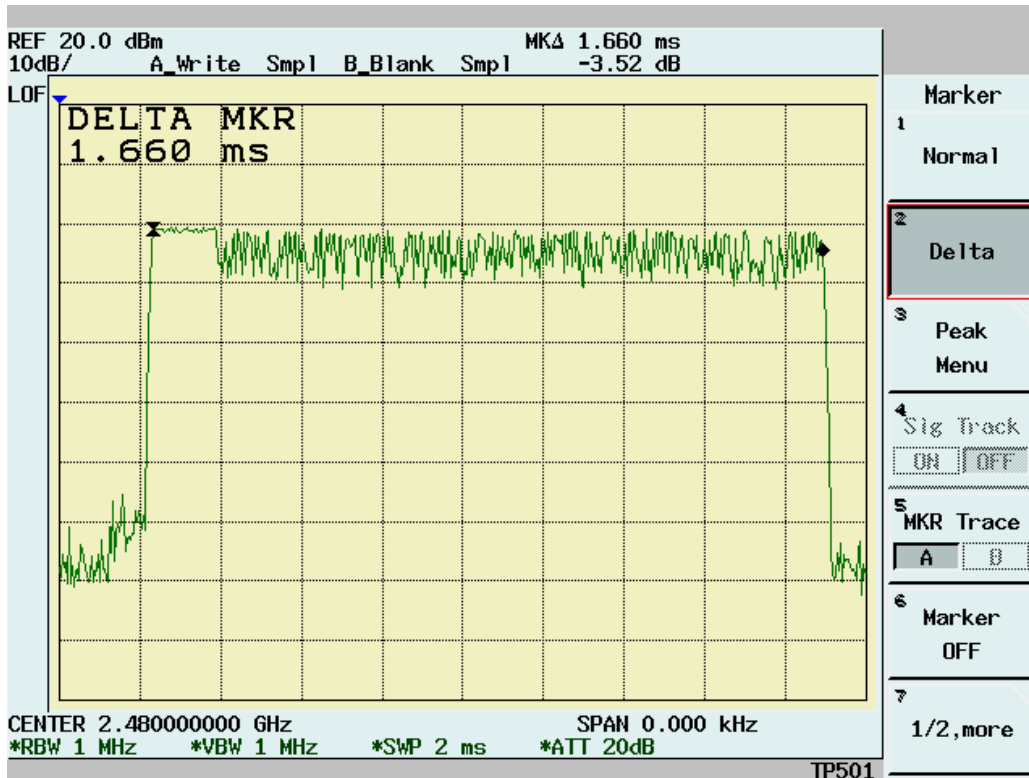

Channel 78 DH5:

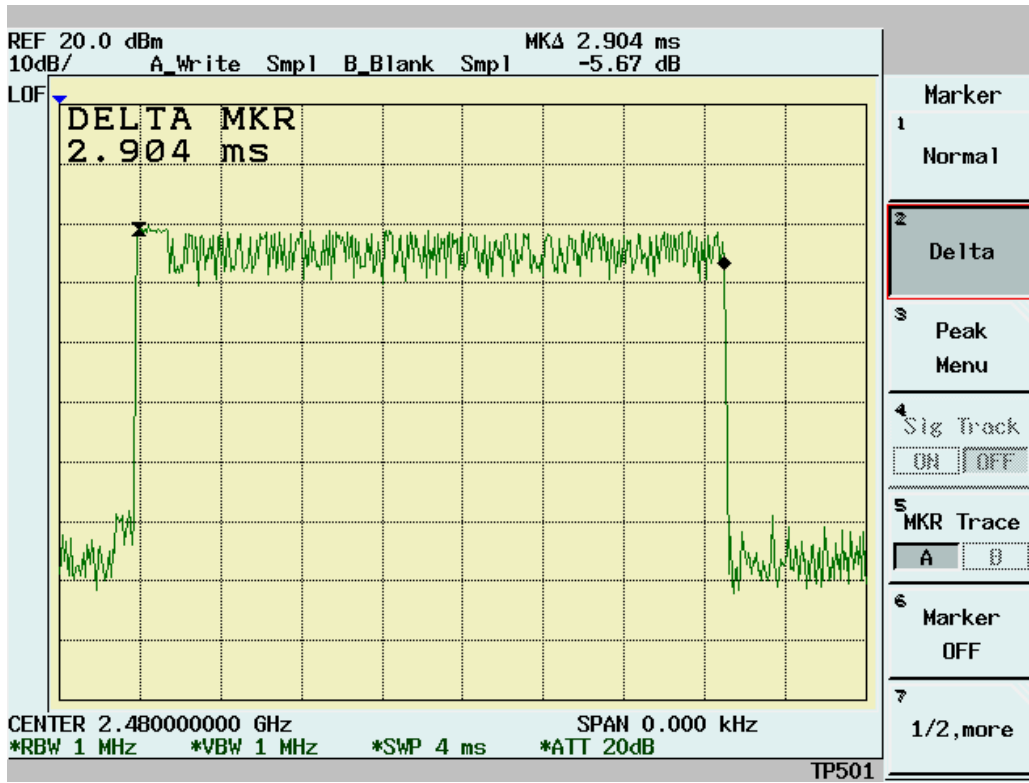

Test condition: Data Rate= 3MBps

Dwell Time

Temperature (°C):25

Test Engineer:Jerry Chiou

Humidity (%):55

Mode	Frequency (MHz)	Spectrum	Test	Limit (ms)	Pass/Fail
		Reading (µs)	Result (ms)		
DH1	2402	406	259.84	< 400	Pass
DH3	2402	1656	353.28	< 400	Pass
DH5	2402	2904	371.71	< 400	Pass

Mode	Frequency (MHz)	Spectrum	Test	Limit (ms)	Pass/Fail
		Reading (µs)	Result (ms)		
DH1	2441	406	259.84	< 400	Pass
DH3	2441	1656	353.28	< 400	Pass
DH5	2441	2904	371.71	< 400	Pass

Mode	Frequency (MHz)	Spectrum	Test	Limit (ms)	Pass/Fail
		Reading (µs)	Result (ms)		
DH1	2480	406	259.84	< 400	Pass
DH3	2480	1656	353.28	< 400	Pass
DH5	2480	2912	372.74	< 400	Pass

Note:

A period time=79x0.4(s)=31.6(s)

CH00	DH1 time slot=	$406 \frac{(\mu s) * (1600 / (1 * 79)) * 31.6}{=}$	259.84 (ms)
	DH3 time slot=	$1656 \frac{(\mu s) * (1600 / (3 * 79)) * 31.6}{=}$	353.28 (ms)
	DH5 time slot=	$2904 \frac{(\mu s) * (1600 / (5 * 79)) * 31.6}{=}$	371.71 (ms)
CH39	DH1 time slot=	$406 \frac{(\mu s) * (1600 / (1 * 79)) * 31.6}{=}$	259.84 (ms)
	DH3 time slot=	$1656 \frac{(\mu s) * (1600 / (3 * 79)) * 31.6}{=}$	353.28 (ms)
	DH5 time slot=	$2904 \frac{(\mu s) * (1600 / (5 * 79)) * 31.6}{=}$	371.71 (ms)
CH78	DH1 time slot=	$406 \frac{(\mu s) * (1600 / (1 * 79)) * 31.6}{=}$	259.84 (ms)
	DH3 time slot=	$1656 \frac{(\mu s) * (1600 / (3 * 79)) * 31.6}{=}$	353.28 (ms)
	DH5 time slot=	$2912 \frac{(\mu s) * (1600 / (5 * 79)) * 31.6}{=}$	372.74 (ms)

Channel 00 DH1:

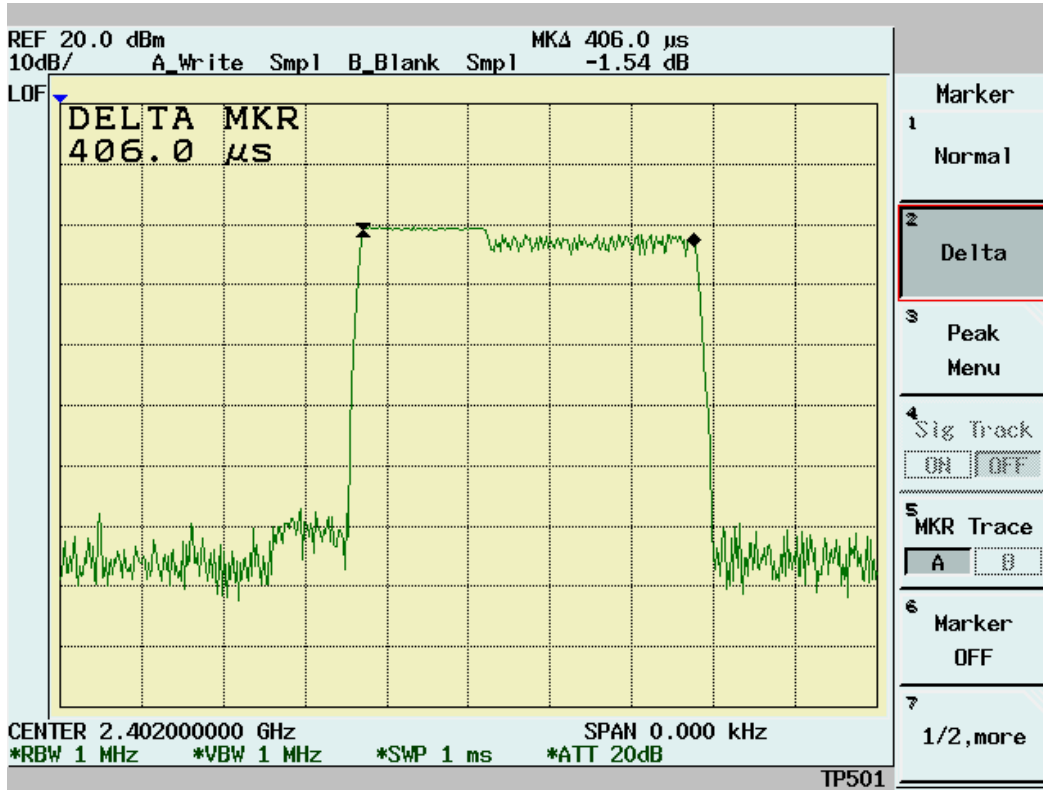

Channel 00 DH3:

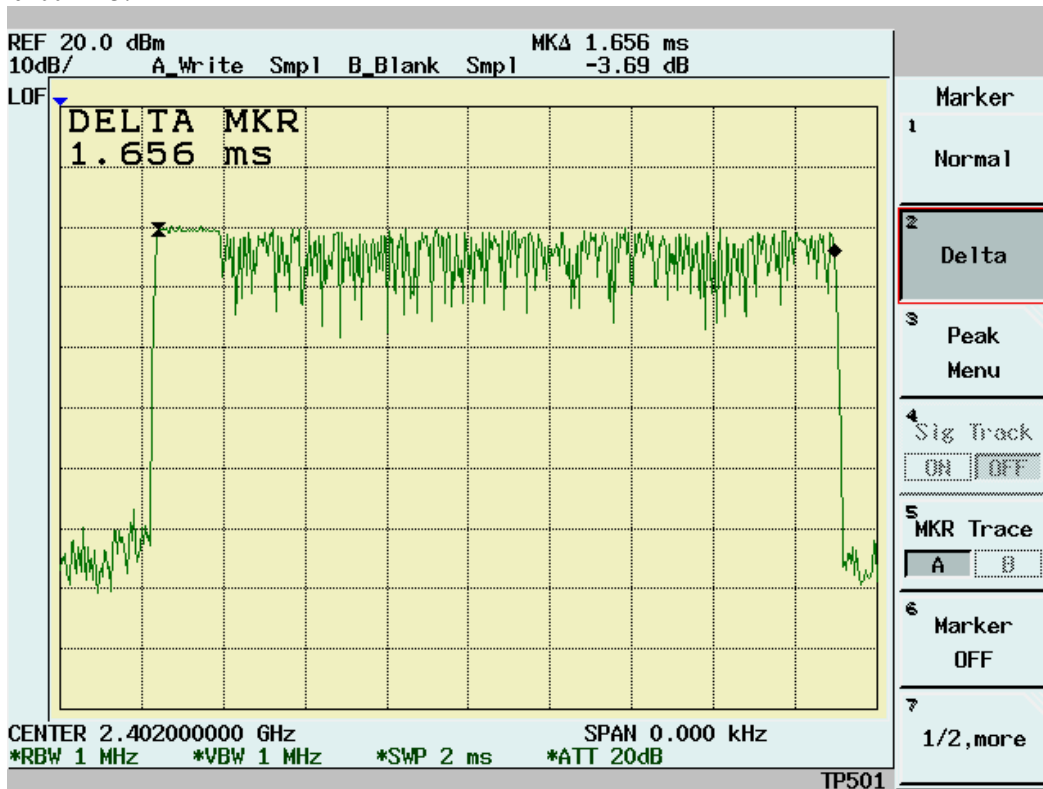

Channel 00 DH5:

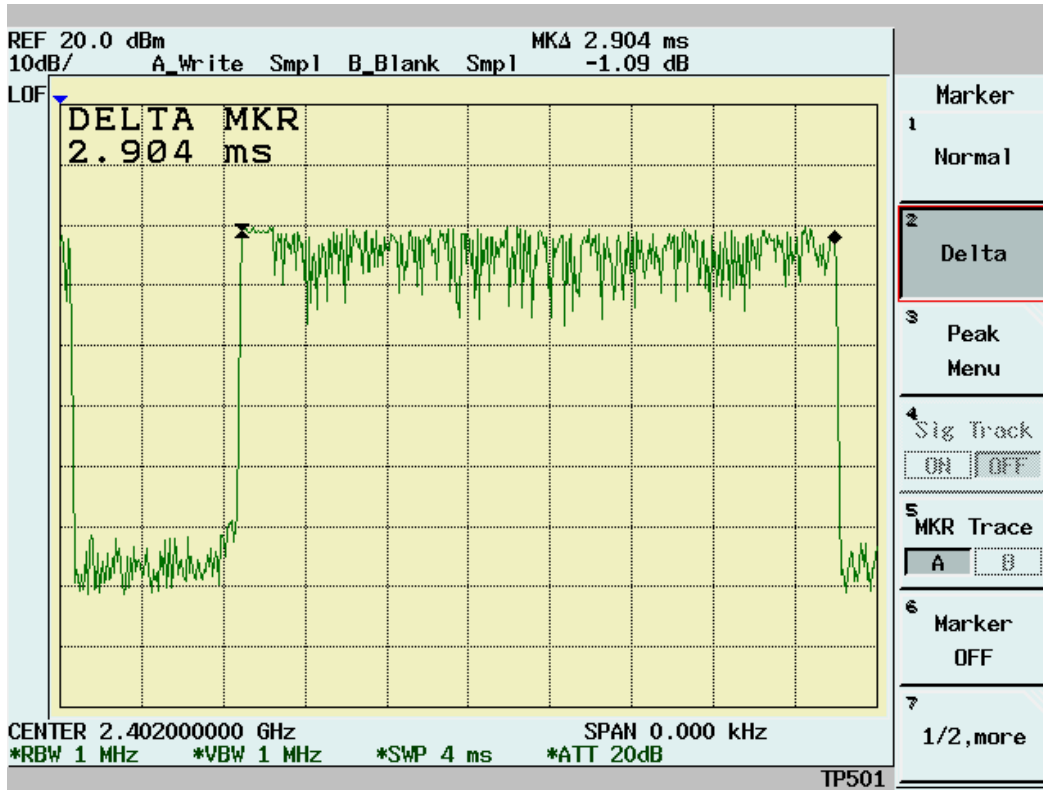

Channel 39 DH1:

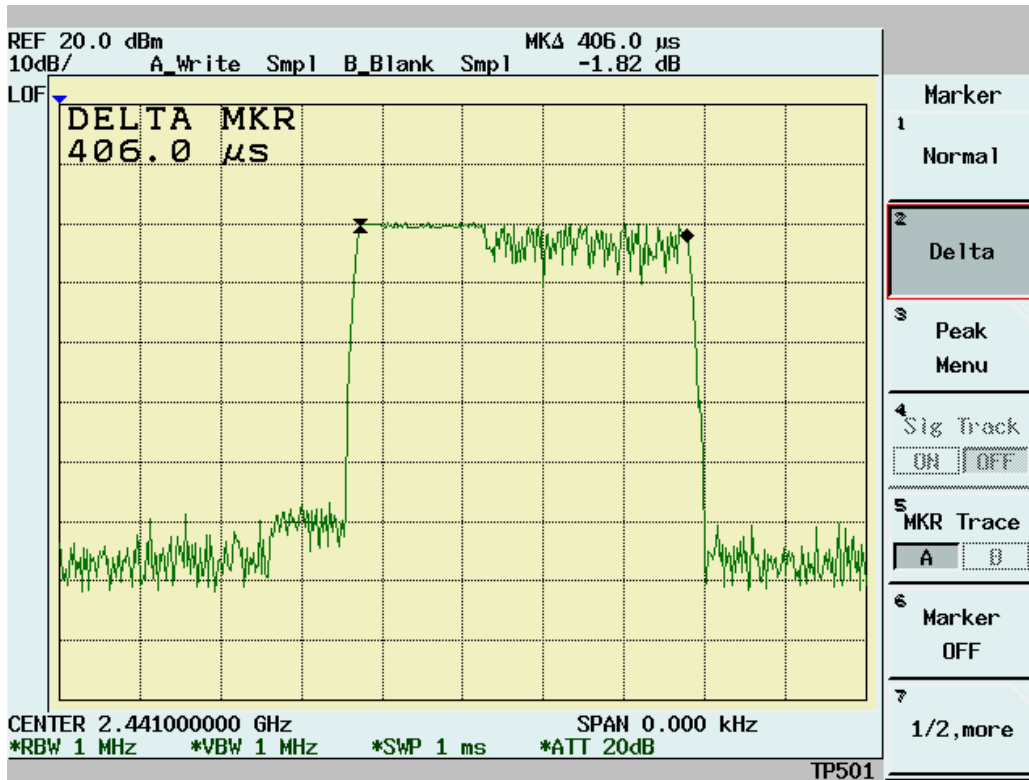

Channel 39 DH3:

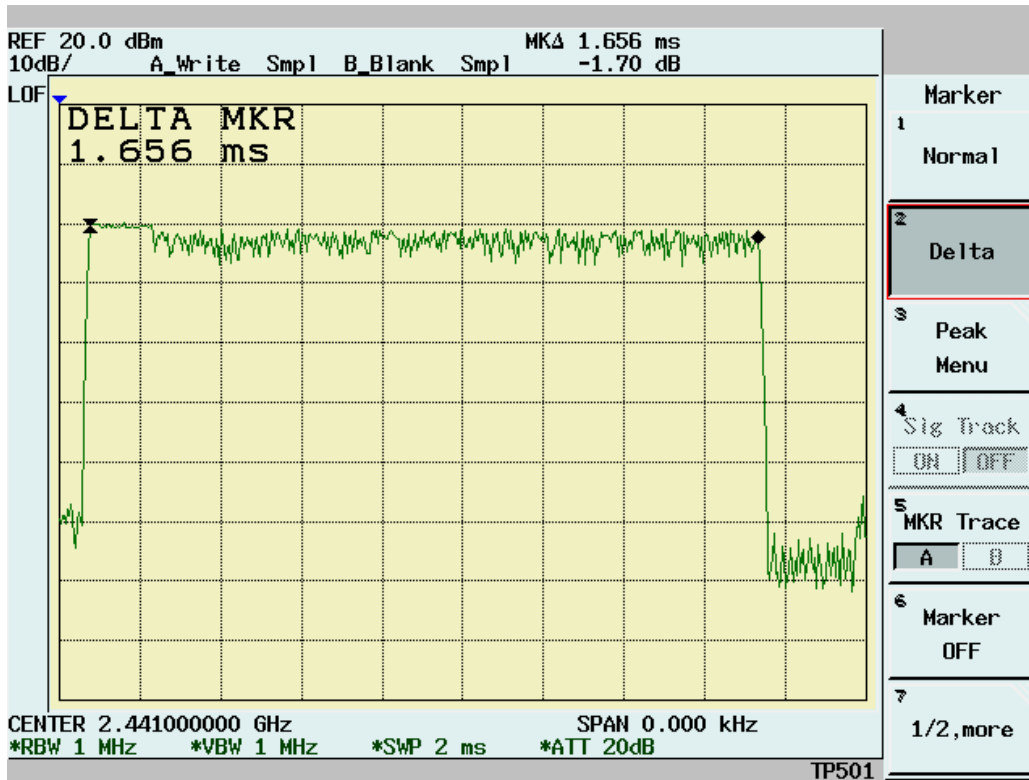

Channel 39 DH5:

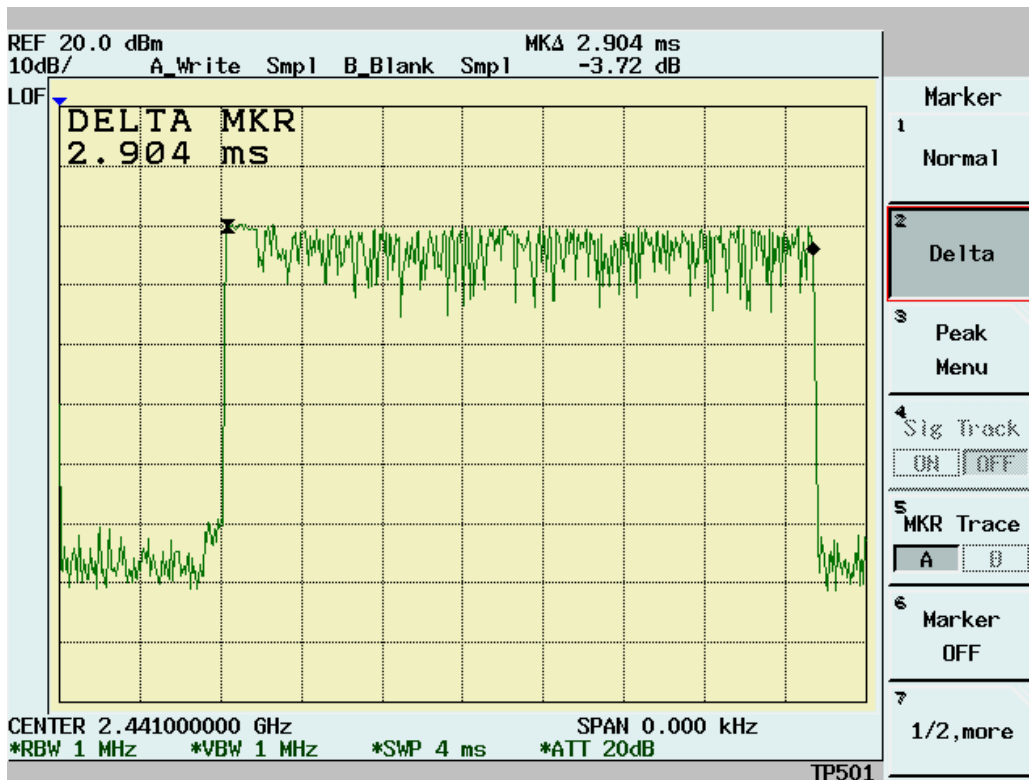

Channel 78 DH1:

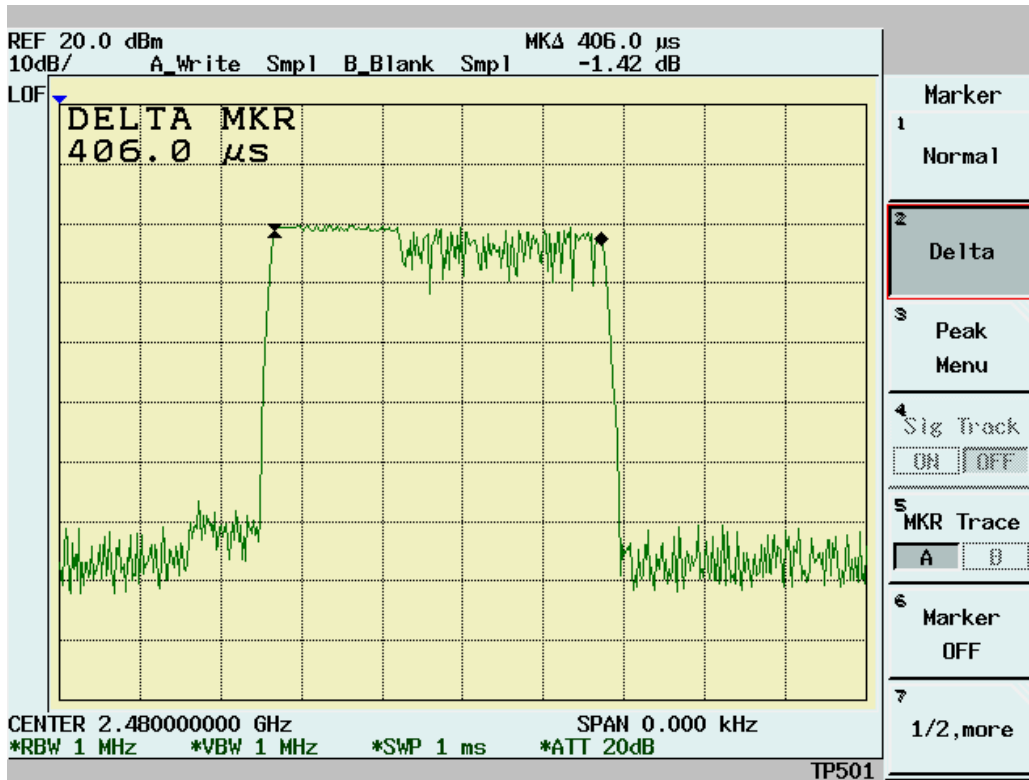

Channel 78 DH3:

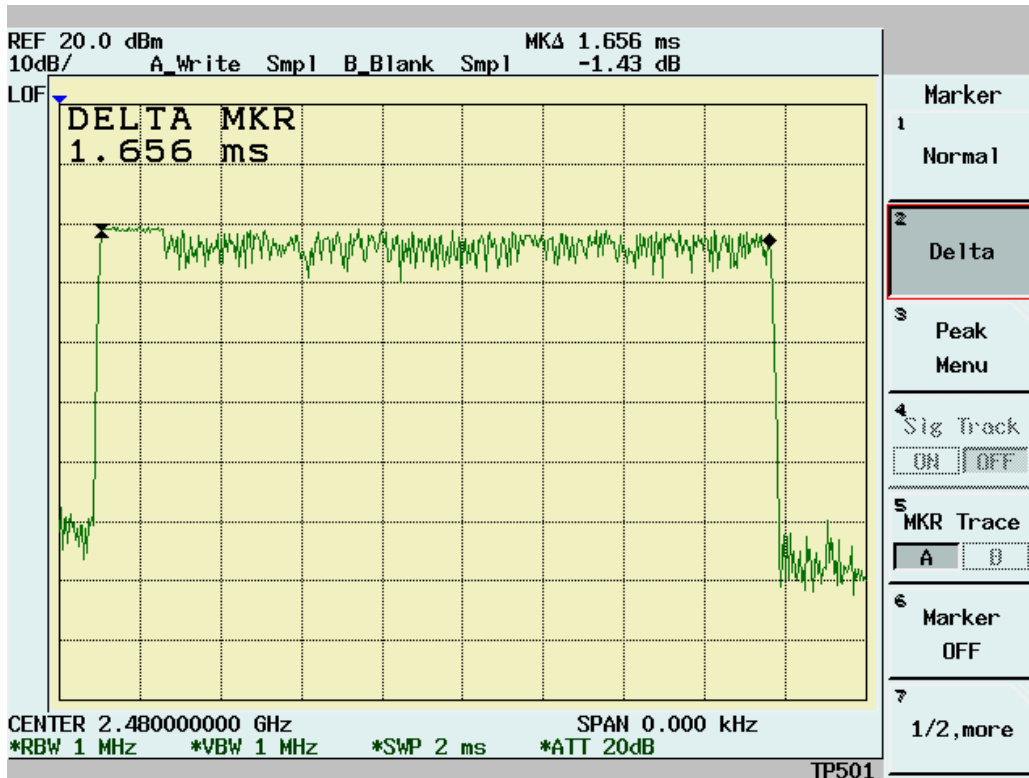

Channel 78 DH5:

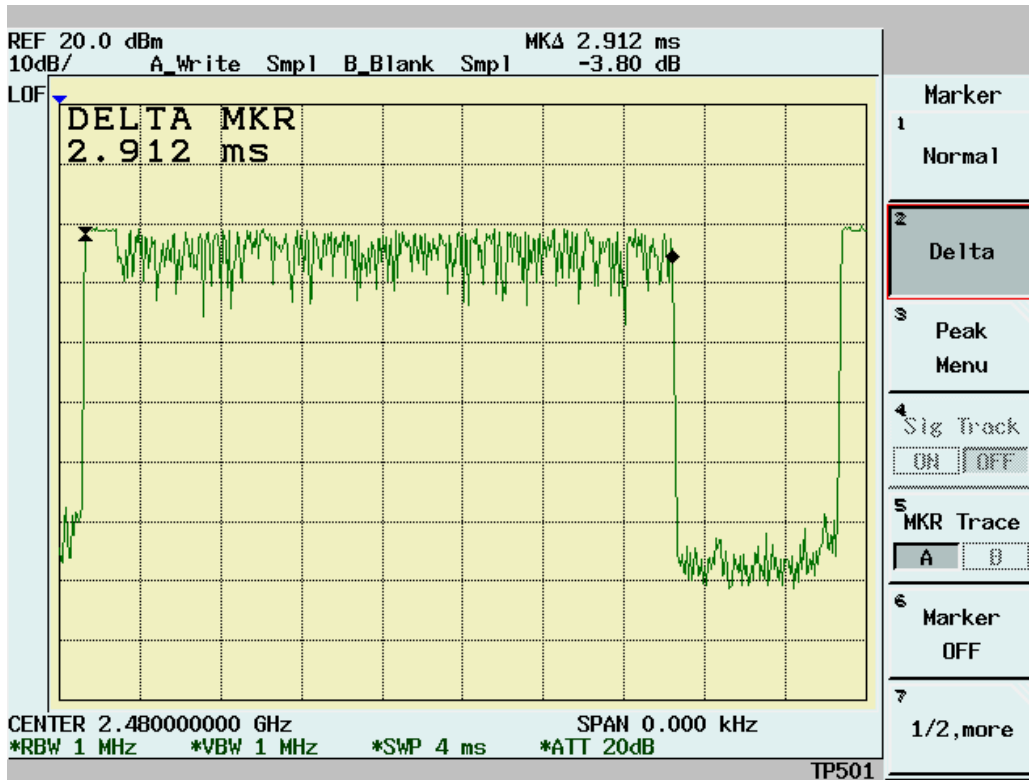

5. Appendix

5.1 Appendix A: Measurement Procedure for Power line Conducted Emissions

The measurements are performed in a 3.5m x 3.4m x 2.5m shielded room, which referred as Conduction 01 test site, or a 3m x 3m x 2.3m test site, which referred as Conduction 02 test site. The EUT was placed on non-conduction 1.0m x 1.5m table, which is 0.8 meters above an earth-grounded.

Power to the EUT was provided through the LISN which has the Impedance (50ohm/50uH) vs. Frequency Characteristic in accordance with the required standard. Power to the LISNs were filtered to eliminate ambient signal interference and these filters were bonded to the ground plane. Peripheral equipment required to provide a functional system (support equipment) for EUT testing was powered from the second LISN through a ganged, metal power outlet box which is bonded to the ground plane at the LISN.

If the EUT is supplied with a flexible power cord, the power cord length in excess of the distance separating the EUT from the LISN shall be folded back and forth at the center of the lead so as to form a bundle not exceeding 40cm in length. If the EUT is provided with a permanently coiled power cord, bundling of the cord is not required. If the EUT is supplied without a power cord, the EUT shall be connected to the LISN by a power cord of the type specified by the manufacturer which shall not be longer than 1 meter. The excess power cord shall be bundled as described above. If a non-flexible power cord is provided with the EUT, it shall be cut to the length necessary to attach the EUT to the LISN and shall not be bundled.

The interconnecting cables were arranged and moved to get the maximum emission. Both the line of power cord, hot and neutral, were measured.

The highest emissions were analyzed in details by operating the spectrum analyzer in fixed tuned mode to determine the nature of the emissions and to provide information which could be useful in reducing their amplitude.

5.2 Appendix B: Test Procedure for Radiated Emissions

Preliminary Measurements in the Anechoic Chamber

The radiated emissions are initially measured in the anechoic chamber at a measurement distance of 3 meters. Desktop EUT are placed on a wooden stand 0.8 meter in height. The measurement antenna is 3 meters from the EUT. The test setup in anechoic chamber is the same as open site. The turntable rotated 360°. The antenna height is varied from 1-2.5m. The primary objective of the radiated measurements in the anechoic chamber is to identify the frequency spectrum in the absence of the electromagnetic environment existing on the open test site. The frequencies can then be pre-selected on the open test site to obtain the corresponding amplitude. The initial scan is made with the spectrum analyzer in automatic sweep mode. The spectrum peaks are then measured manually to determine the exact frequencies.

Measurements on the Open Site or 10m EMC Chamber

The radiated emissions test will then be repeated on the open site or 10m EMC chamber to measure the amplitudes accurately and without the multiple reflections existing in the shielded room. The EUT and support equipment are set up on the turntable of one of the 3 or 10 meter open field sites. Desktop EUT are set up on a wooden stand 0.8 meter above the ground.

For the initial measurements, the receiving antenna is varied from 1-4 meter height and is changed in the vertical plane from vertical to horizontal polarization at each frequency. Both readings are recorded with the quasi-peak detector with 120KHz bandwidth. For frequency between 30 MHz and 1000MHz, the reading is recorded with peak detector or quasi-peak detector. For frequency above 1 GHz, the reading is recorded with peak detector or average detector with 1 MHz bandwidth.

At the highest amplitudes observed, the EUT is rotated in the horizontal plane while changing the antenna polarization in the vertical plane to maximize the reading. The interconnecting cables were arranged and moved to get the maximum emission. Once the maximum reading is obtained, the antenna elevation and polarization will be varied between specified limits to maximize the readings.

5.3 Appendix C: Test Equipment

5.3.1 Test Equipment List

Location	Equipment Name	Brand	Model	S/N	Last Cal. Date	Next Cal. Date
Conduction	Coaxial Cable 1F-C2	Harbourindustries	RG400	1F-C2	02/13/2007	02/13/2008
Conduction	Digital Hygro-Thermometer Conduct	MicroLife	HT-2126G	ISL-Conduction02	12/26/2007	12/26/2008
Conduction	EMI Receiver 07	Schwarzbeck Mess-Elektronik	FCKL 1528	1528-201	08/31/2007	08/30/2008
Conduction	LISN 01	R&S	ESH2-Z5	890485/013	01/03/2008	01/03/2009
Conduction	LISN 06	R&S	ESH3-Z5	828874/009	12/14/2007	12/14/2008
Radiation	BILOG Antenna 08	Schaffner	CBL6112B	2756	06/13/2007	06/12/2008
Radiation	Coaxial Cable Chmb 02-10M	Belden	RG-8/U	Chmb 02-10M	02/13/2007	02/12/2008
Radiation	Digital Hygro-Thermometer Chmb 02	MicroLife	HT-2126G	Chmb 02	12/26/2007	12/26/2008
Radiation	EMI Receiver 02	HP	85460A	3448A00183	12/29/2007	12/28/2008
Radiation	Spectrum Analyzer 13	Advantest	R3132	121200411	03/16/2007	03/15/2008
Radiation	Horn Antenna 02	Com-Power	AH-118	10088	01/14/2008	01/14/2009
Radiation	Horn Antenna 04	Com-Power	AH-826	081-001	03/13/2007	03/13/2008
Radiation	Horn Antenna 05	Com-Power	AH-640	100A	11/16/2007	11/15/2008
Radiation	Microwave Cable RF SK-01	HUBER+SUHNERAG.	Sucoflex 102	22139 /2	06/01/2007	06/01/2008
Radiation	Preamplifier 09	MITEQ	AFS44-00102 650-40-10P-44	858687	04/02/2007	04/02/2008
Radiation	Preamplifier 10	MITEQ	JS-26004000-2 7-5A	818471	12/28/2007	12/28/2008
Radiation	High Pass Filter 01	HEWLETT-PACKARD	84300-80038	001	N/A	N/A
Radiation	High Pass Filter 02	HEWLETT-PACKARD	84300-80039	005	N/A	N/A
Radiation	Spectrum Analyzer 14	Advantest	R3182	140600028	12/06/2007	12/06/2008

Note: Calibration is traceable to NIST or national or international standards.

5.3.2 Software for Controlling Spectrum/Receiver and Calculating Test Data

Radiation/Conduction	Filename	Version	Issued Date
Conduction	Tile.exe	1.12E	7/7/2000
Radiation	Tile.exe	1.12C	6/16/2000

5.4 Appendix D: Layout of EUT and Support Equipment

5.4.1 General Conducted Test Configuration

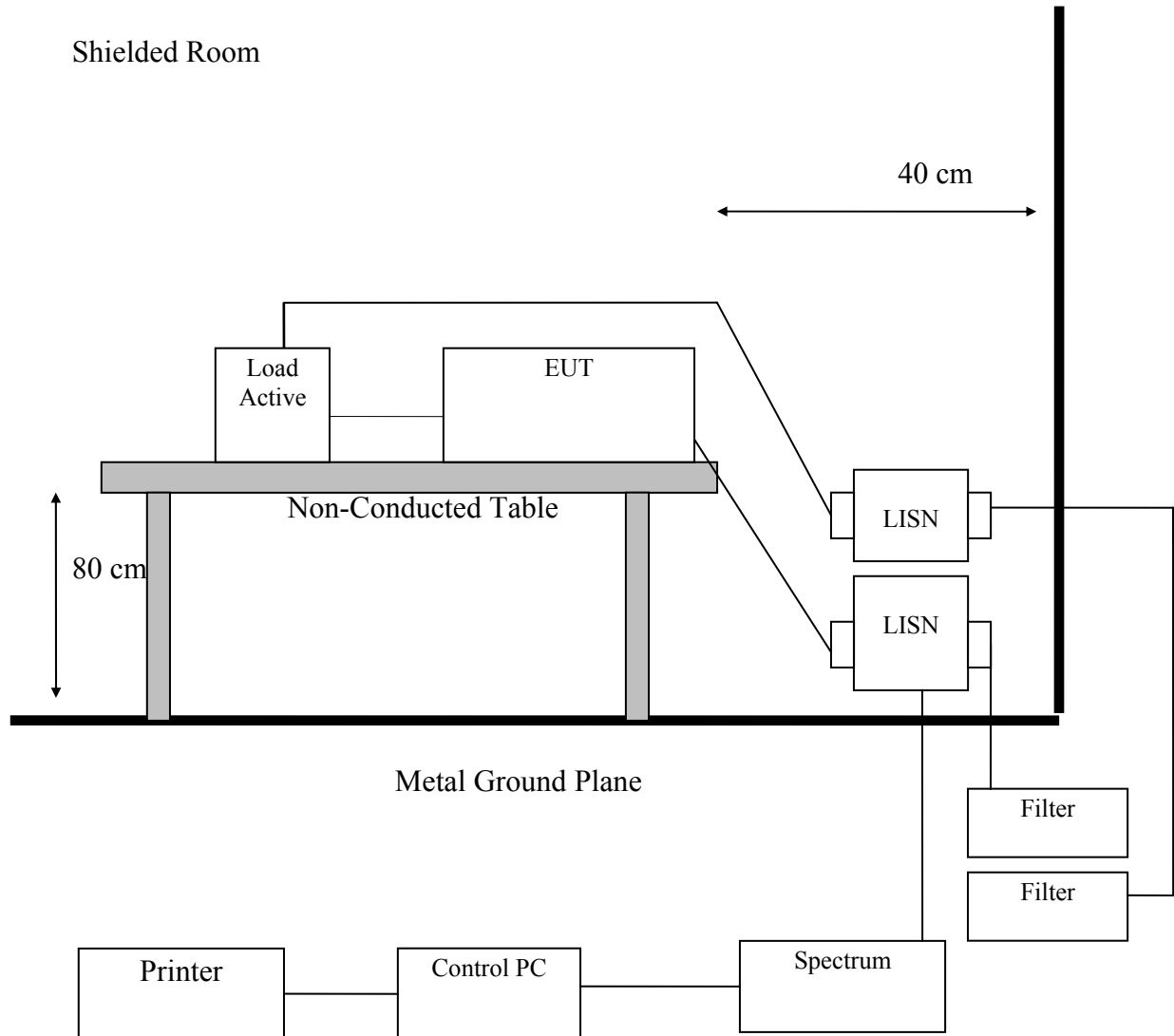

5.4.2 General Radiation Test Configuration

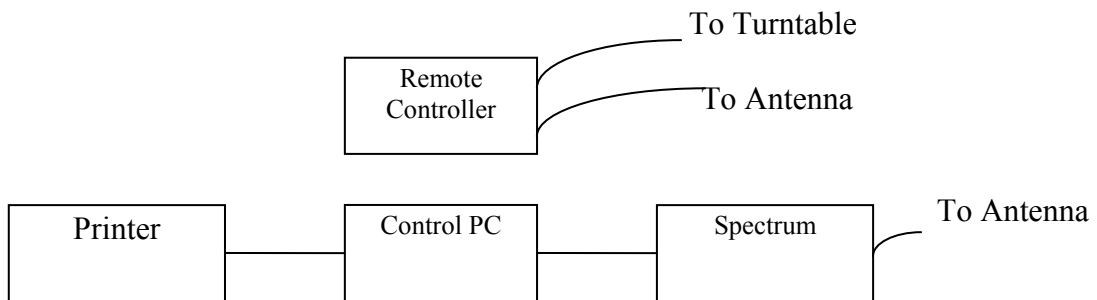
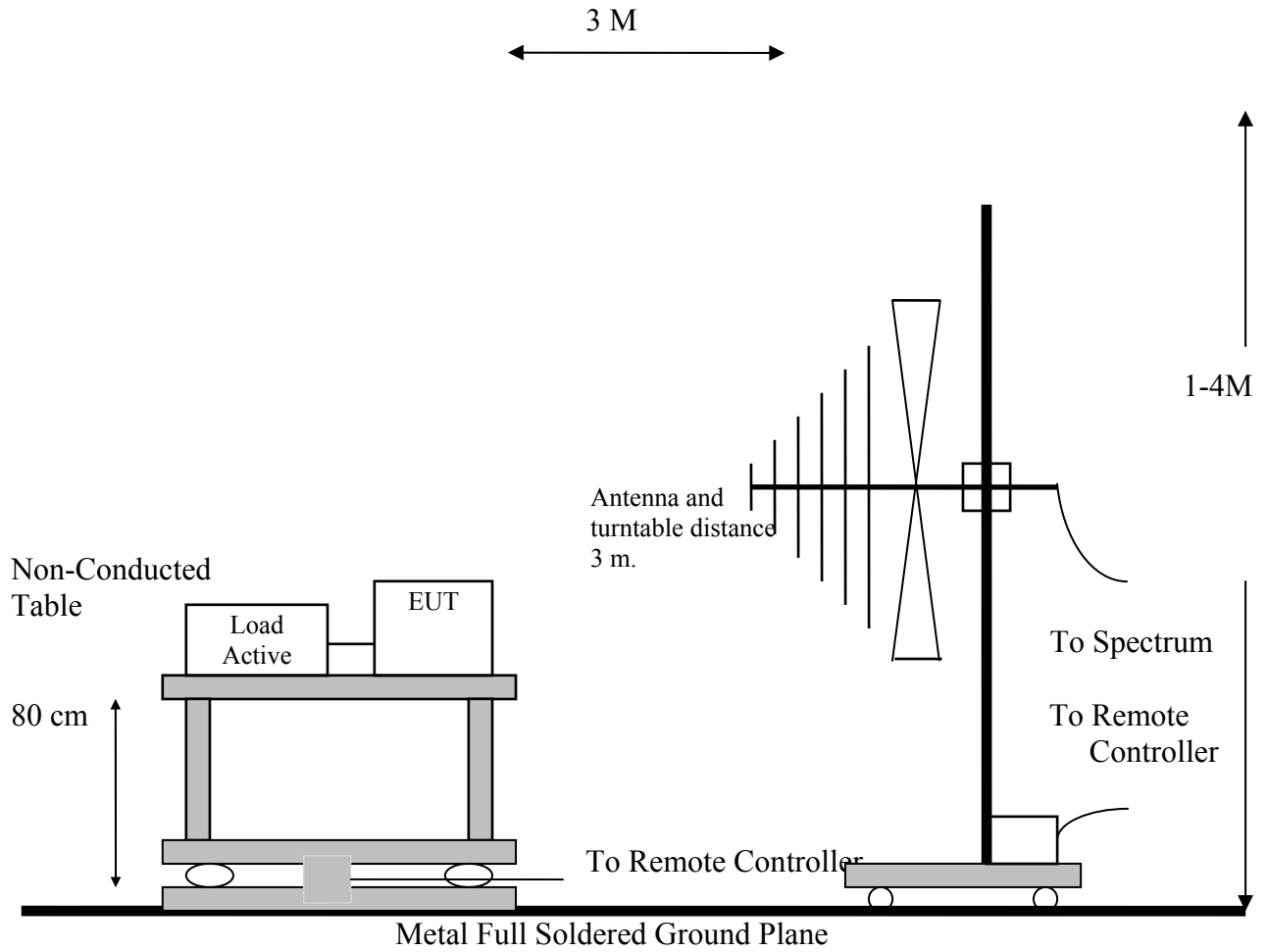

5.5 Appendix E: Accuracy of Measurement

The measurement uncertainty refers to CISPR 16-4-2:2003. The coverage factor $k = 2$ yields approximately a 95 % level of confidence.

<Conduction 02>: ± 1.77 dB

<Chamber 12 (3M)>

30MHz~1GHz: ± 3.306 dB

1GHz~18GHz: ± 2.62 dB

18GHz~26GHz: ± 3.609 dB

26GHz~40GHz: ± 2.702 dB

5.6 Appendix F: Photographs of EUT Configuration Test Set Up

The Front View of Highest Conducted Set-up For EUT



The Back View of Highest Conducted Set-up For EUT



The Front View of Highest Radiated Set-up For EUT

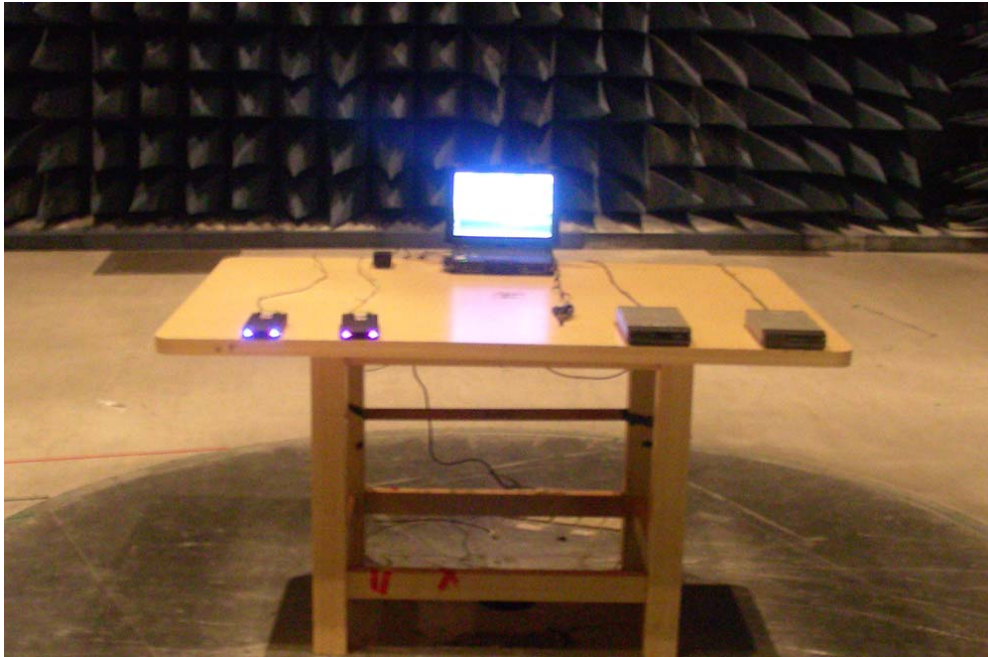

The Back View of Highest Radiated Set-up For EUT

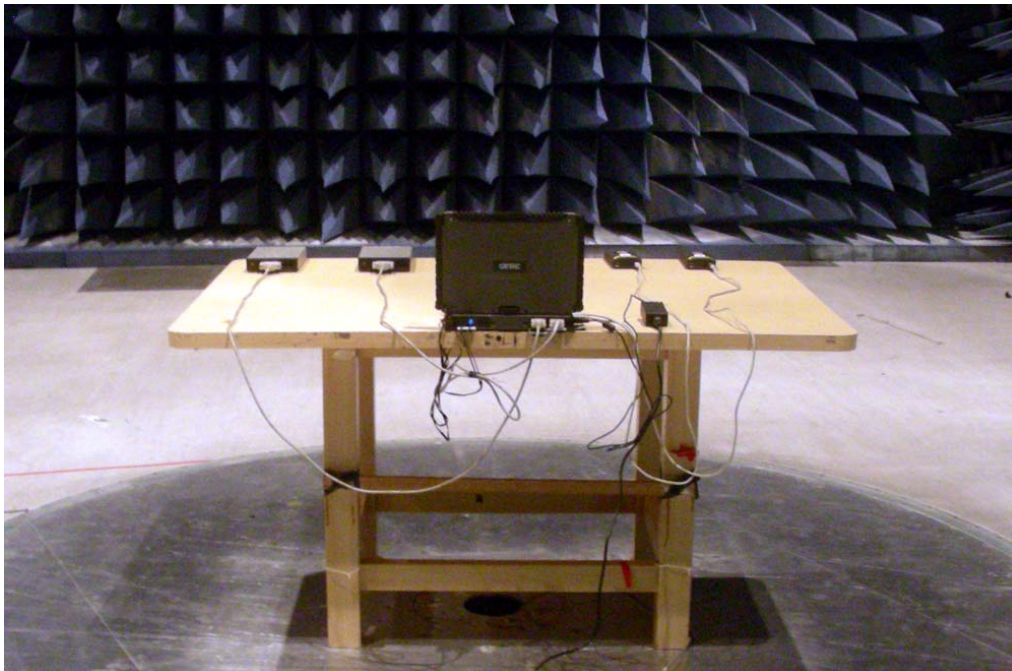

5.7 Appendix G: Antenna Specification

Please refer to the attached file.