

TEST REPORT

of

FCC Part 2,22&24

Product : **Notebook Personal Computer**

Model(s): **V100**

(with SIERRA HSDPA Module, Model:MC8775V)

Brand: GETAC

Applicant: **MITAC Technology Corporation**

Address: **4F, No.1, R&D Road 2,
Hsinchu Science-Based industrial Park,
Hsinchu 300, Taiwan**

Test Performed by:

International Standards Laboratory

<Lung-Tan LAB>

*Site Registration No.

BSMI: SL2-IN-E-0013; TAF: 0997;

IC: IC4164-1; VCCI: R-1435, C-1440, T-299; NEMKO: ELA 113B

*Address:

No. 120, Lane 180, San Ho Tsuen, Hsin Ho Rd.

Lung-Tan Hsiang, Tao Yuan County 325, Taiwan

*Tel : 886-3-407-1718; Fax: 886-3-407-1738

Report No.: **ISL-07LR030FCP22**

Issue Date : **2008/05/14**

Contents of Report

1.	General	1
1.1	Certification of Accuracy of Test Data	1
2.	Test Results Summary	2
3.	Description of Equipment Under Test (EUT)	3
4.	TEST RESULTS (Cellular850/PCS1900)	5
4.1	Peak Power Output [Section 2.1046, 22.913(a), 24.232(b)]	5
4.1.1	Test Procedure(Conducted)	5
4.1.2	Test Procedure(Radiated)	5
4.1.3	Test Setup	6
4.1.4	Conducted Test Data:	7
4.1.5	Radiated Test Data:.....	8
4.2	Occupied Bandwidth [Section 2.1049, 22.917(b),24.238(b)]	10
4.2.1	Test Procedure	10
4.2.2	Test Setup	10
4.2.3	Test Data.....	11
4.3	Spurious Emission At Antenna Terminals (+/-1MHz).....	17
4.3.1	Test Procedure	17
4.3.2	Test Setup	17
4.3.3	Test Data.....	18
4.4	Spurious Emission Measurement [Section 2.1051,2.1053, 22.917(a), 24.238(b)]	22
4.4.1	Test Procedure(Conducted)	22
4.4.2	Test Procedure(Radiated)	22
4.4.3	Test Setup	23
4.4.4	Conducted Test Data:	25
4.4.5	Radiated Test Data:	26
4.5	Frequency Stability Under Temperature Variations & Voltage Variations	28
4.5.1	Test Procedure	28
4.5.2	Test Setup	28
4.5.3	Test Data:.....	29
5.	Test Equipment.....	31
6.	Appendix	32
6.1	Appendix A: Photographs of EUT Configuration Test Set Up	32
6.2	Appendix B: Photographs of EUT.....	32

1. General

1.1 Certification of Accuracy of Test Data

Standards: CFR 47 Part 2
CFR 47 Part 22H
CFR 47 Part 24E

Test Procedure: EIA/TIA-603A

Equipment Tested: Notebook Personal Computer

Model: V100

Applied by: MITAC Technology Corporation

Sample received Date: 2007/10/26

Final test Date : refer to the date of test data

Test Result **PASS**

Test Site: Chamber 05, Conduction 02, Humidity Chamber

Reporter: Jiin Lee

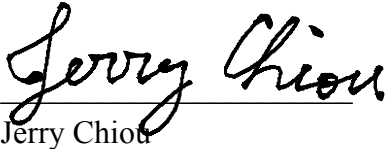
Test Engineer: 
Jerry Chion

All the tests in this report have been performed and recorded in accordance with the standards described above and performed by an independent electromagnetic compatibility consultant, International Standards Laboratory.

The test results contained in this report accurately represent the measurements of the characteristics and the energy generated by sample equipment under test at the time of the test. The sample equipment tested as described in this report is in compliance with the limits of above standards.

Approve & Signature

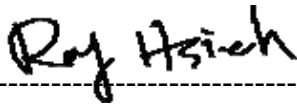

Roy Hsieh / Manager

Test results given in this report apply only to the specific sample(s) tested under stated test conditions. This report shall not be reproduced other than in full without the explicit written consent of ISL. This report totally contains 34 pages, including 1 cover page, 1 contents page, and 32 pages for the test description.

This test data shown below is traceable to NIST or national or international standard. International Standards Laboratory certifies that no party to this application has been denied the FCC benefits pursuant to Section 5301 of the Anti-Drug Abuse Act of 1988, 21 U.S.C. 853(a).

2. Test Results Summary

The functions of EUT has been tested according to the FCC regulations listed below:

Tested Standards: 47 CFR Part 2,22&24			
Standard Section	Test Type	Result	Remarks
§2.1046 §22.913 §24.232	Peak Power Output	Pass	
§2.1049 §22.917 §24.238	Occupied Bandwidth	Pass	
§2.1049 §22.917 §24.238	Spurious Emission At Antenna Terminals (+/-1MHz)	Pass	
§2.1051 §2.1053 §22.917 §24.238	Spurious emissions	Pass	
§2.1055 §22.355 §24.235	Frequency Stability Under Temperature Variations & Voltage Variations	Pass	

3. Description of Equipment Under Test (EUT)

Product Name	Notebook Personal Computer
Model No.	V100
FCC ID	MAU027
TX Frequency	824MHz~849MHz 1850MHz ~ 1910MHz
Rx Frequency	869MHz~894MHz 1930MHz ~ 1990MHz
Antenna Type	Internal
Maximum Power(conducted)	GPRS(GMSK) 850 MHz : 31.8dBm 1900 MHz : 29.6dBm EDGE(8PSK) 850 MHz : 27.37dBm 1900 MHz : 26.46dBm
Maximum Power(radiated)	GPRS(GMSK) 850 MHz : 29.12dBm 1900 MHz : 27.14dBm EDGE(8PSK) 850 MHz : 21.28dBm 1900 MHz : 19.88dBm
Power Rating	By Notebook PC
Antenna Type	PIFA Antenna
Antenna Gain	0.52dBi(850MHz), 2.06dBi(1900MHz)
Type of Antenna Connector	I-PEX
HW version	2.1.4.0
SW version	R2.0.1.1 Build 1444
Emission designators	GPRS:200KGXW EDGE:200KG7W
Voltage and Current in final PA	Cellular850: EUT idle: DC19V,0.90A GPRS transmitting Max. power: DC19V, 0.99A PCS1900: EUT idle: DC19V,0.90A GPRS transmitting Max. power: DC19V, 0.95A
LCD Panel	Panel 1:LTD 104KA1S Panel 2:LTD 121EXEV

Test configuration:

configuration	LCD	CPU	Adapter Type	Hard Disk	Modem Card	Wireless LAN Card	Battery	DDR
1	Toshiba(Model: LTD104 KA1S)	Genuine intel U2500 1.2GHz	EPS (Model: F10903-A)	Toshiba (Model:M K1234GSX) 120G	Conexant (Model: RD-02-D330)	Intel(Model :WM3945 ABG)	MITAC(M odel:BP-L C2600/33-0 151)	Hnnix(M odel:PC2 -5300S5 55-12)
2	Toshiba(Model: LTD121E XEV)	Genuine intel U2500 1.2GHz	EPS (Model: F10903-A)	Toshiba (Model:M K1234GSX) 120G	Conexant (Model: RD-02-D330)	Intel(Model :WM3945 ABG)	MITAC(M odel:BP-L C2600/33-0 151)	Hnnix(M odel:PC2 -5300S5 55-12)

All types of LCD 、 CPU 、 Adapter Type 、 Hard Disk 、 Modem Card 、 Wireless LAN Card 、 Battery 、 DDR with related components have been tested, only shown the worst data using the following configuration in this report.

configuration	LCD	CPU	Adapter Type	Hard Disk	Modem Card	Wireless LAN Card	Battery	DDR
2	Toshiba(Model: LTD121E XEV)	Genuine intel U2500 1.2GHz	EPS (Model: F10903-A)	Toshiba (Model:M K1234GSX) 120G	Conexant (Model: RD-02-D330)	Intel(Model :WM3945 ABG)	MITAC(M odel:BP-L C2600/33-0 151)	Hnnix(M odel:PC2 -5300S5 55-12)

4. TEST RESULTS (Cellular850/PCS1900)

4.1 Peak Power Output [Section 2.1046, 22.913(a), 24.232(b)]

4.1.1 Test Procedure(Conducted)

1. The Transmitter output of EUT was connected to the Base Simulator
2. Base Simulator setting is listed below:.

Channels Tested:	Cellular850: Low Channel Mid. Channel High Channel PCS1900: Low Channel Mid. Channel High Channel
Detector Function:	Peak Power Mode

4.1.2 Test Procedure(Radiated)

1. The equipment under test was set up on the 10 meter chamber with measurement distance of 3 meters. The EUT was placed on a non-conductive table 150cm above ground.
2. Any changes made to the configuration, or modifications made to the EUT, during testing are noted in the following test record.
3. The maximum readings by varying the height of antenna from 1~4meters and then rotating the turntable were recorded. Both polarization of antenna, horizontal and vertical with EUT's X, Y Z axis, were measured.
4. Base Simulator setting is listed below:.

Channels Tested:	Cellular850: Low Channel Mid. Channel High Channel PCS1900: Low Channel Mid. Channel High Channel
Detector Function:	Peak Power Mode
Span:	100MHz
Resolution Bandwidth (RBW):	1MHz(GPRS/EDGE)
Video Bandwidth (VBW)	3MHz(GPRS/EDGE)
Sweep Time	500ms

4.1.3 Test Setup

■ General Conducted Test Configuration

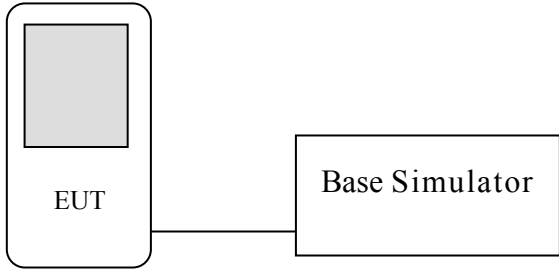

■ General Radiation Test Configuration

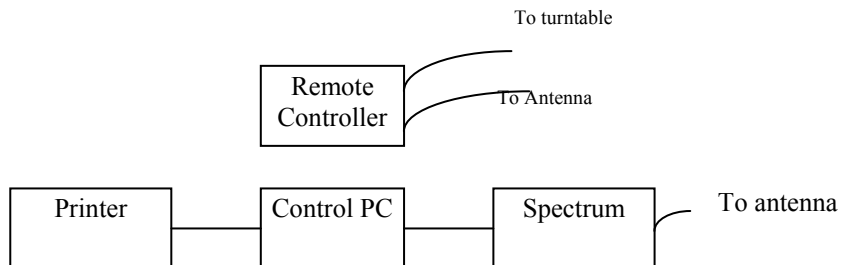
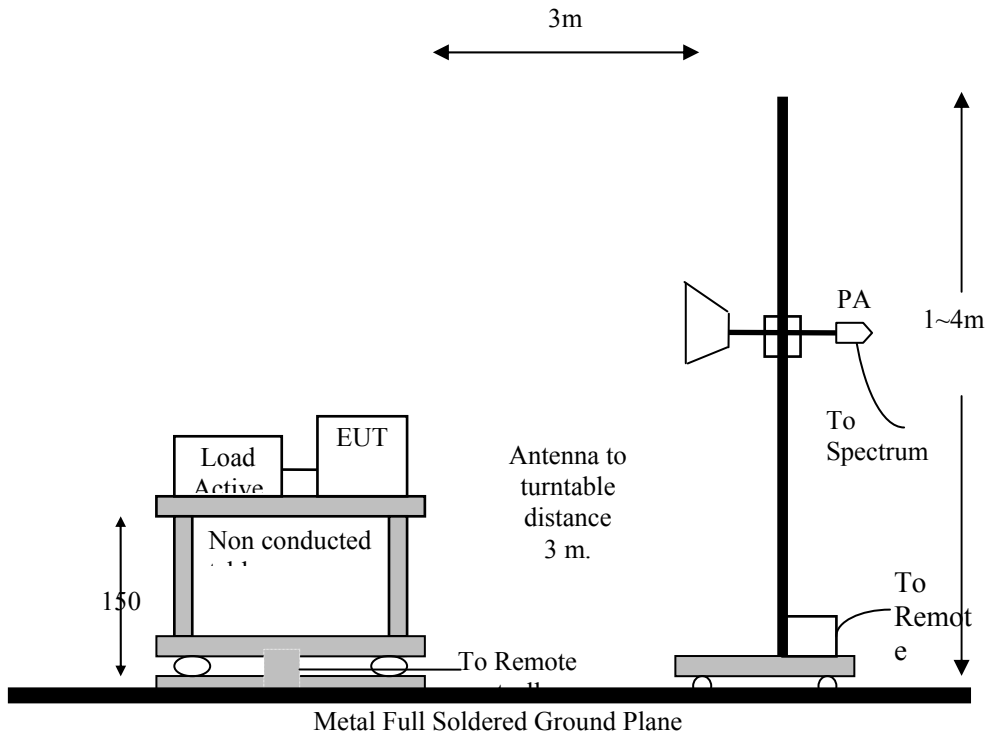

4.1.4 Conducted Test Data:

■ GPRS Maximum Peak Output Power(Conducted)

Cellular850

Channel	Frequency	Reading	Path loss	Results		Limit	Pass/Fail
	(MHz)	(dBm)		(dBm)	(W)	(W)	
128	824.2	30.7	1.0	31.7	1.174	7	Pass
190	836.6	30.8	1.0	31.8	1.202	7	Pass
251	848.8	30.7	1.0	31.7	1.174	7	Pass

PCS1900

Channel	Frequency	Reading	Path loss	Results		Limit	Pass/Fail
	(MHz)	(dBm)		(dBm)	(W)	(W)	
512	1850.2	27.7	1.5	29.2	0.588	2	Pass
661	1880.0	28	1.5	29.5	0.63	2	Pass
810	1909.8	28.1	1.5	29.6	0.645	2	Pass

■ EDGE Maximum Peak Output Power(Conducted)

Cellular850

Channel	Frequency	Reading	Path loss	Results		Limit	Pass/Fail
	(MHz)	(dBm)		(dBm)	(W)	(W)	
128	824.2	26.08	1.0	27.08	0.511	7	Pass
190	836.6	26.23	1.0	27.23	0.528	7	Pass
251	848.8	26.37	1.0	27.37	0.490	7	Pass

PCS1900

Channel	Frequency	Reading	Path loss	Results		Limit	Pass/Fail
	(MHz)	(dBm)		(dBm)	(W)	(W)	
512	1850.2	24.56	1.5	26.06	0.404	2	Pass
661	1880.0	24.75	1.5	26.25	0.422	2	Pass
810	1909.8	24.96	1.5	26.46	0.443	2	Pass

4.1.5 Radiated Test Data:

■ **GPRS Maximum Peak Output Power(Radiated) with config. 2**

Cellular850

Channel	Frequency	Raw Results (dBm)	Correction factor (dB)	Results (ERP)		Limit (W)	Pass/Fail
	(MHz)			(dBm)	(W)		
128	824.2	-10.07	37.35	27.28	0.535	7	Pass
190	836.6	-8.63	37.35	28.72	0.745	7	Pass
251	848.8	-8.23	37.35	29.12	0.817	7	Pass

PCS1900

Channel	Frequency	Raw Results (dBm)	Correction factor (dB)	Results (EIRP)		Limit (W)	Pass/Fail
	(MHz)			(dBm)	(W)		
512	1850.2	-12.57	39.71	27.14	0.518	2	Pass
661	1880.0	-13.90	39.71	25.81	0.381	2	Pass
810	1909.8	-13.91	39.71	25.80	0.380	2	Pass

■ **EDGE Maximum Peak Output Power(Radiated) with config. 2**

Cellular850

Channel	Frequency	Raw Results (dBm)	Correction factor (dB)	Results (ERP)		Limit (W)	Pass/Fail
	(MHz)			(dBm)	(W)		
128	824.2	-17.25	37.35	20.10	0.102	7	Pass
190	836.6	-16.32	37.35	21.03	0.127	7	Pass
251	848.8	-16.07	37.35	21.28	0.134	7	Pass

PCS1900

Channel	Frequency	Raw Results (dBm)	Correction factor (dB)	Results (EIRP)		Limit (W)	Pass/Fail
	(MHz)			(dBm)	(W)		
512	1850.2	-19.83	39.71	19.88	0.097	2	Pass
661	1880.0	-20.55	39.71	19.16	0.082	2	Pass
810	1909.8	-20.72	39.71	18.99	0.079	2	Pass

Note:

1. Receiver setting (Peak Detector) : RBW:1MHz; VBW:3MHz ◦
2. Correction factor = Substitution SG Level + Antenna Gain - Cable Loss – Rx. level ◦
3. ERP/EIRP Value = Raw Results + Correction factor ◦

■ **GPRS Maximum Peak Output Power(Radiated) with config. 1**

Cellular850

Channel	Frequency	Raw Results (dBm)	Correction factor (dB)	Results (ERP)		Limit (W)	Pass/Fail
	(MHz)			(dBm)	(W)		
128	824.2	-9.87	37.35	27.48	0.560	7	Pass
190	836.6	-8.55	37.35	28.80	0.759	7	Pass
251	848.8	-8.89	37.35	28.46	0.701	7	Pass

PCS1900

Channel	Frequency	Raw Results (dBm)	Correction factor (dB)	Results (EIRP)		Limit (W)	Pass/Fail
	(MHz)			(dBm)	(W)		
512	1850.2	-13.69	39.71	26.02	0.400	2	Pass
661	1880.0	-14.53	39.71	25.18	0.330	2	Pass
810	1909.8	-13.95	39.71	25.22	0.333	2	Pass

Note:

1. Receiver setting (Peak Detector) : RBW:1MHz; VBW:3MHz ◦
2. Correction factor = Substitution SG Level + Antenna Gain - Cable Loss – Rx. level ◦
3. ERP/EIRP Value = Raw Results + Correction factor ◦

4.2 Occupied Bandwidth [Section 2.1049, 22.917(b),24.238(b)]

4.2.1 Test Procedure

1. The Transmitter output of EUT was connected to the Spectrum analyzer through the directional coupler.
2. Spectrum analyzer setting is listed below:

Channels Tested:	Cellular850: Low Channel Mid. Channel High Channel PCS1900: Low Channel Mid. Channel High Channel
Detector Function:	Peak Mode
Span:	1MHz
Resolution Bandwidth (RBW):	10kHz(GPRS/EDGE)
Video Bandwidth (VBW)	30kHz(GPRS/EDGE)
Sweep Time	500ms

4.2.2 Test Setup

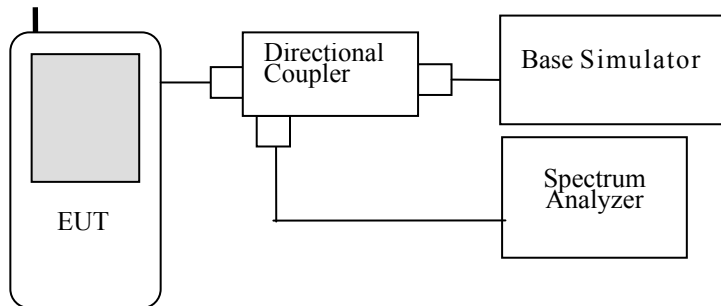

4.2.3 Test Data

GPRS 850 Low Channel

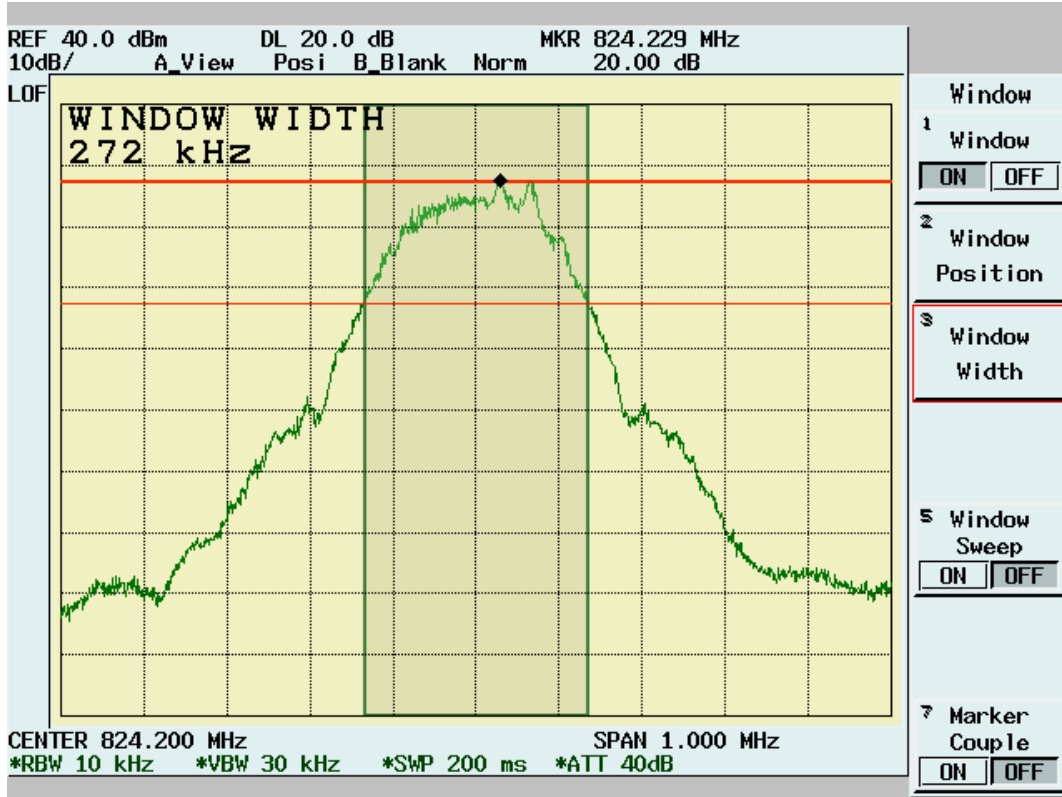

GPRS 850 Mid. Channel

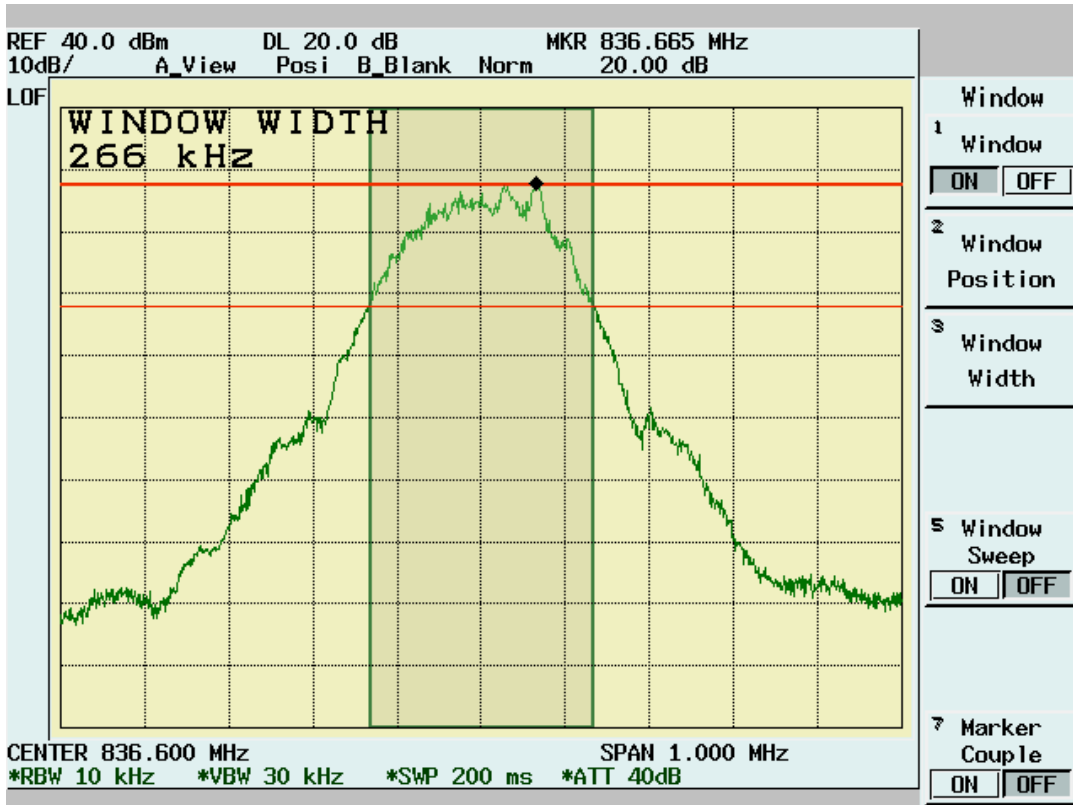

GPRS 850 High Channel

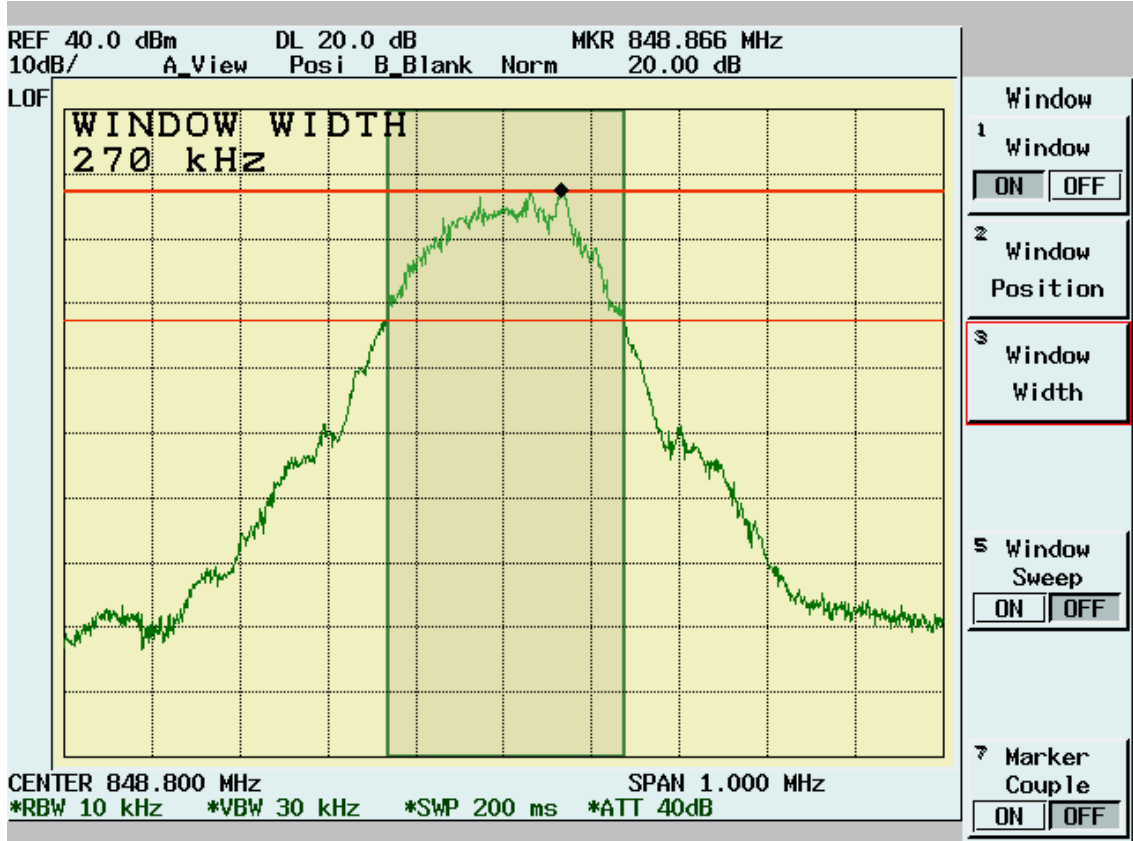

GPRS 1900 Low Channel

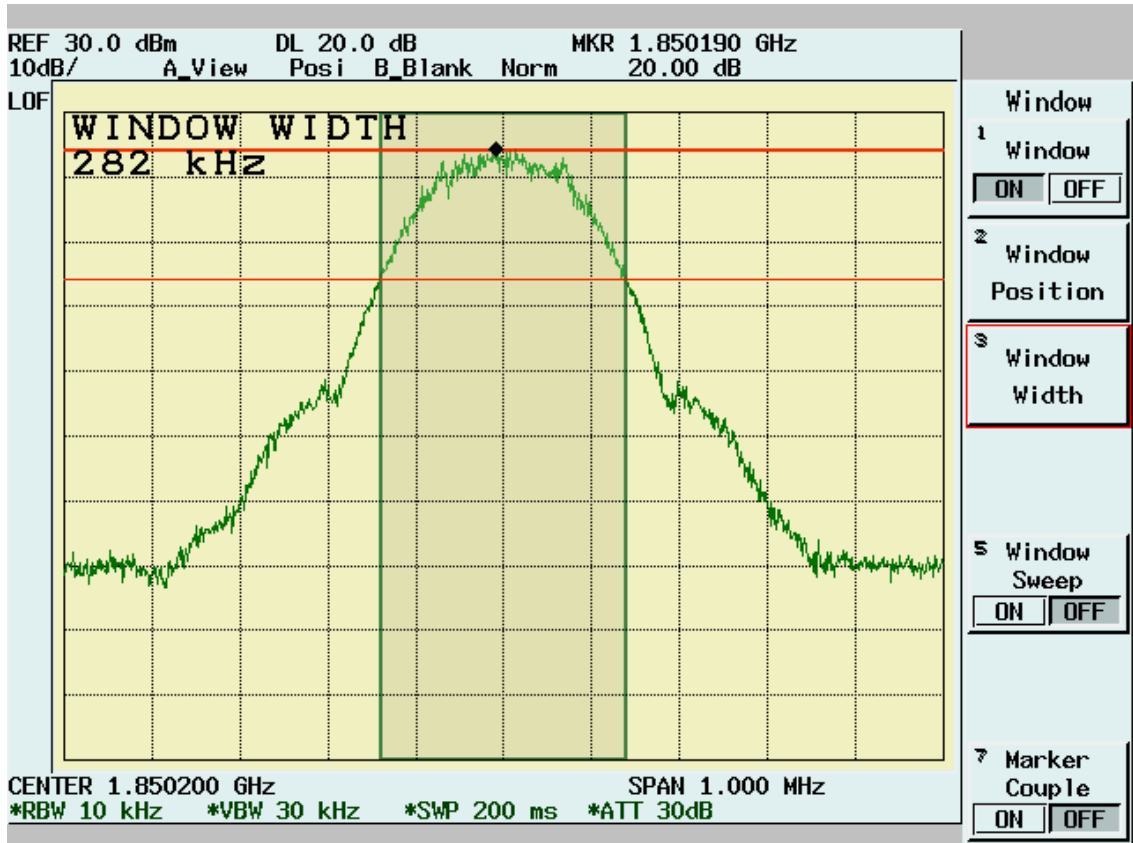

GPRS 1900 Mid. Channel

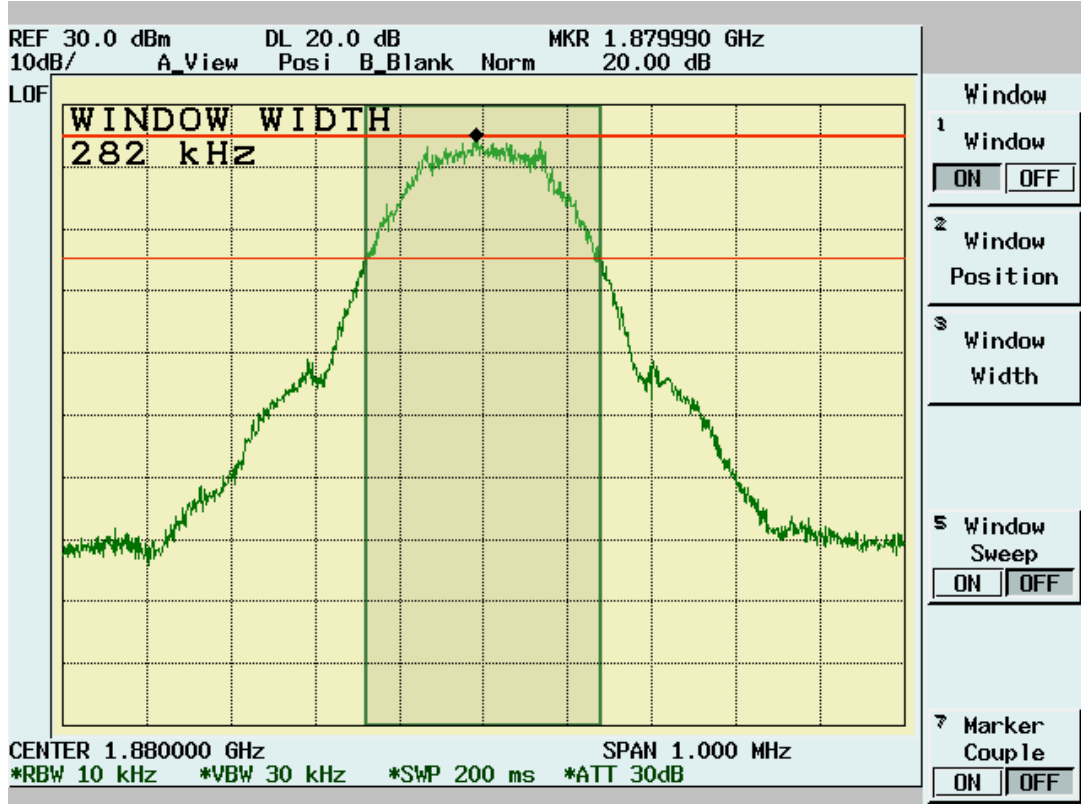

GPRS 1900 High Channel

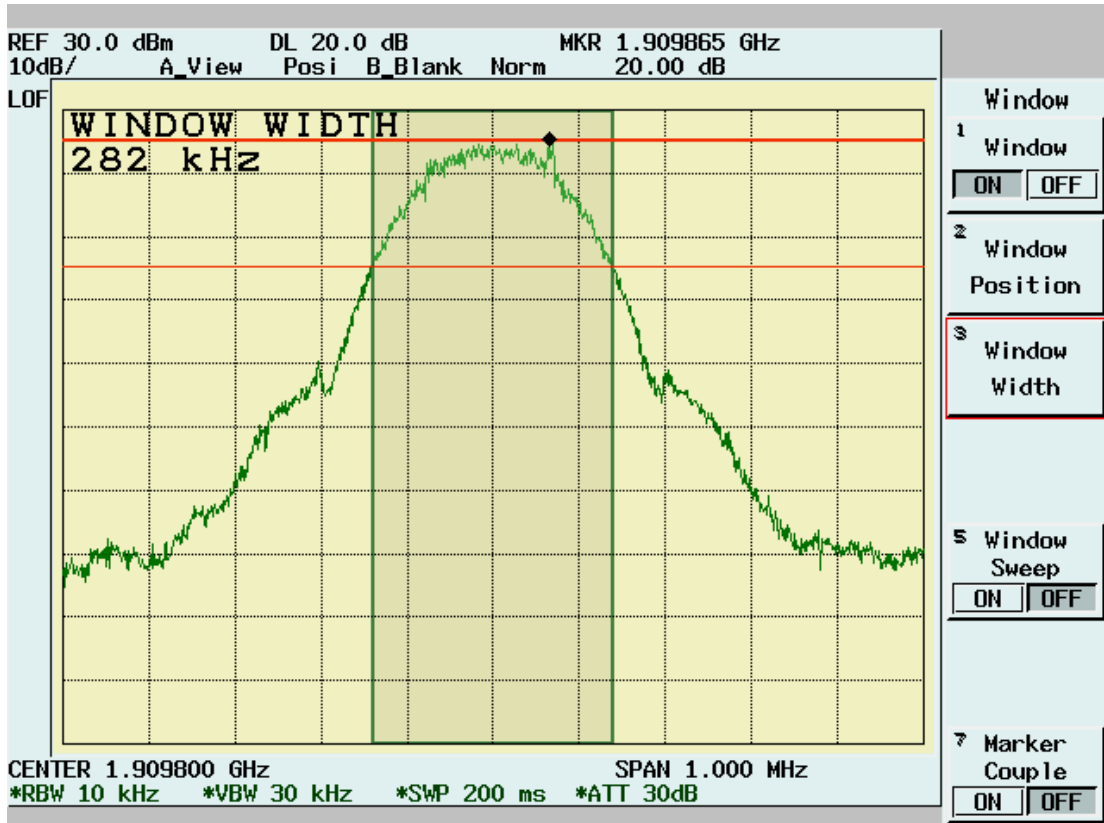

EDGE 850 Low Channel

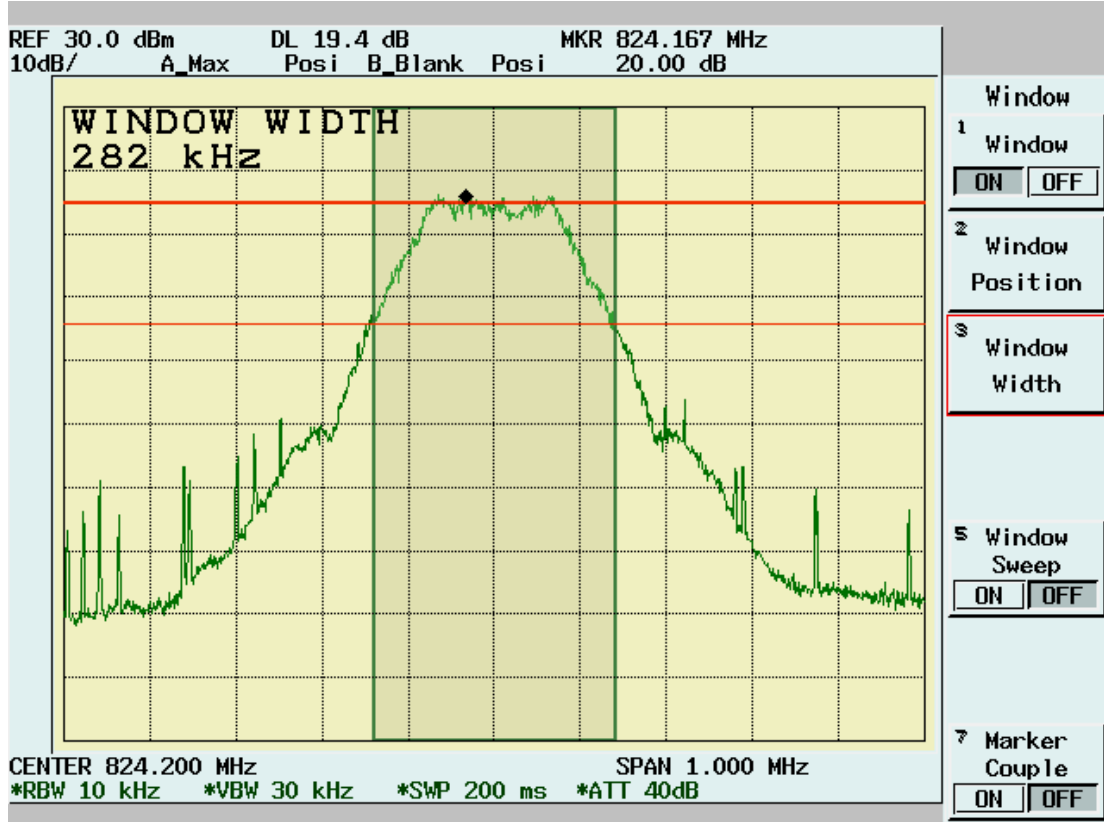

EDGE 850 Mid. Channel

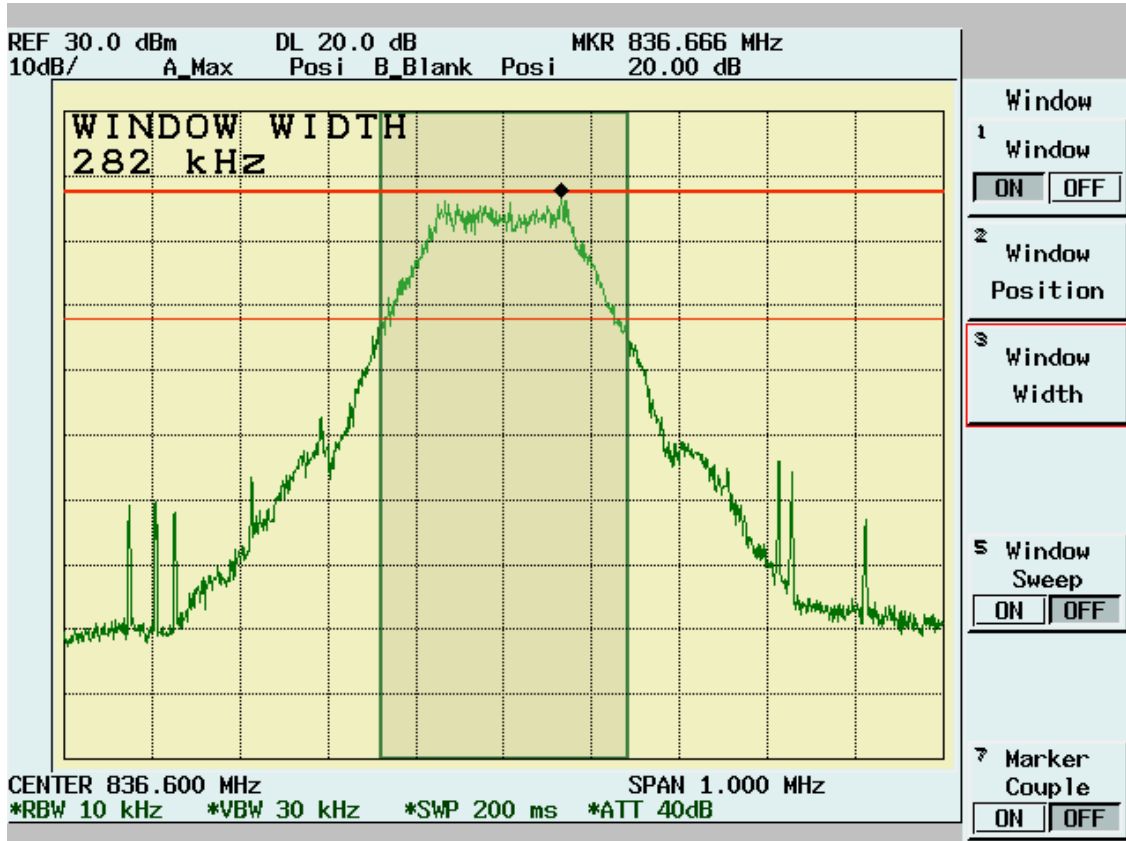

EDGE 850 High Channel

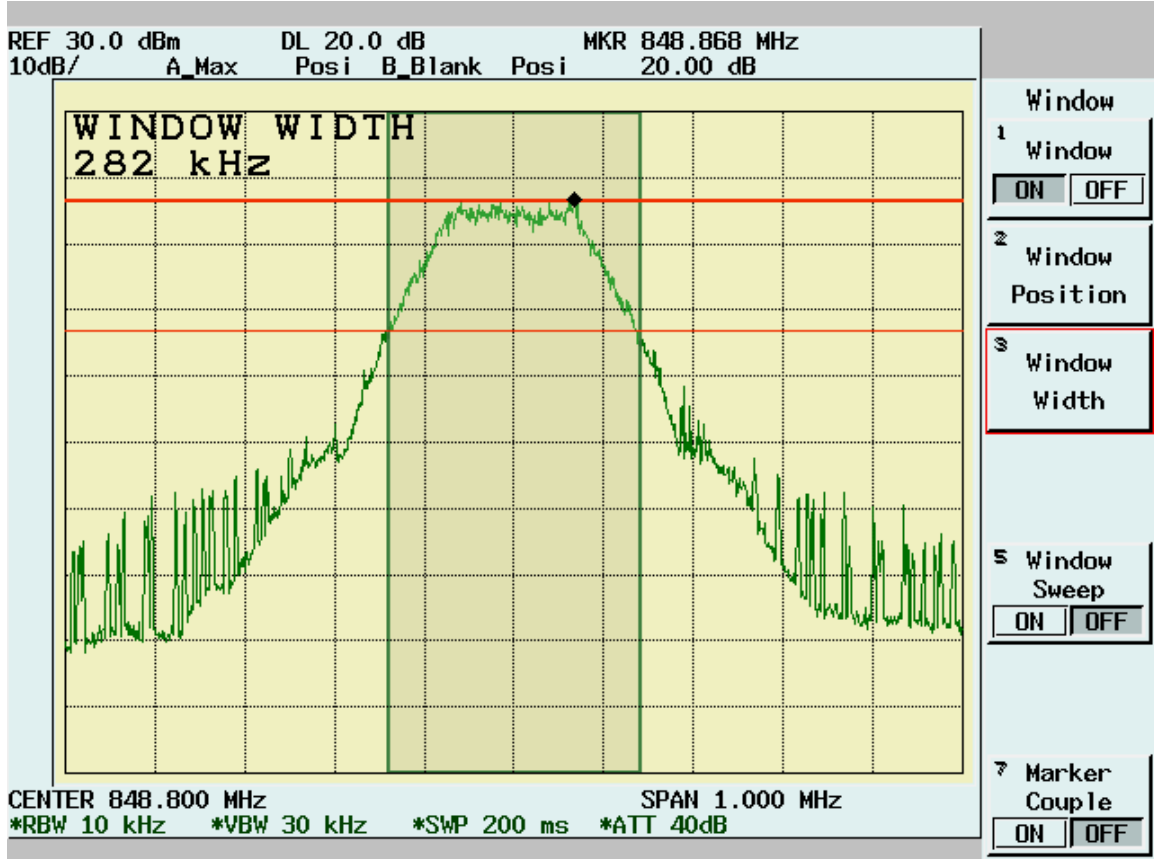

EDGE 1900 Low Channel

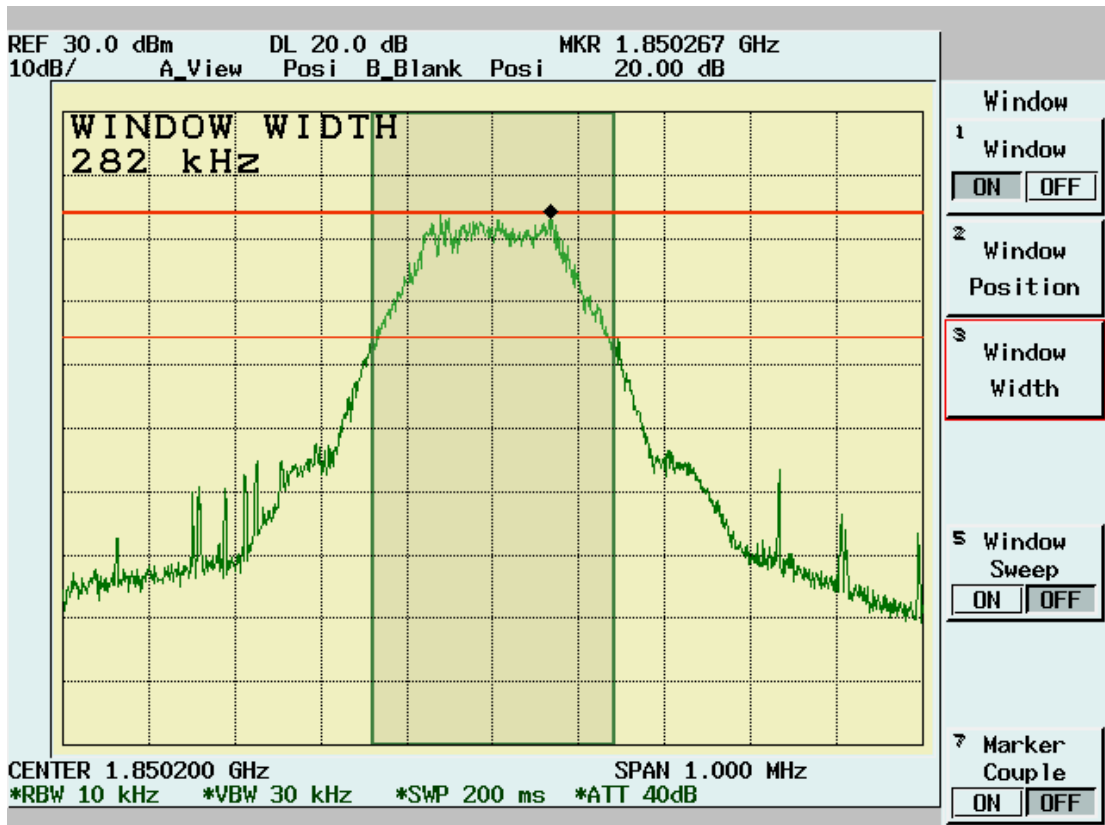

EDGE 1900 Mid. Channel

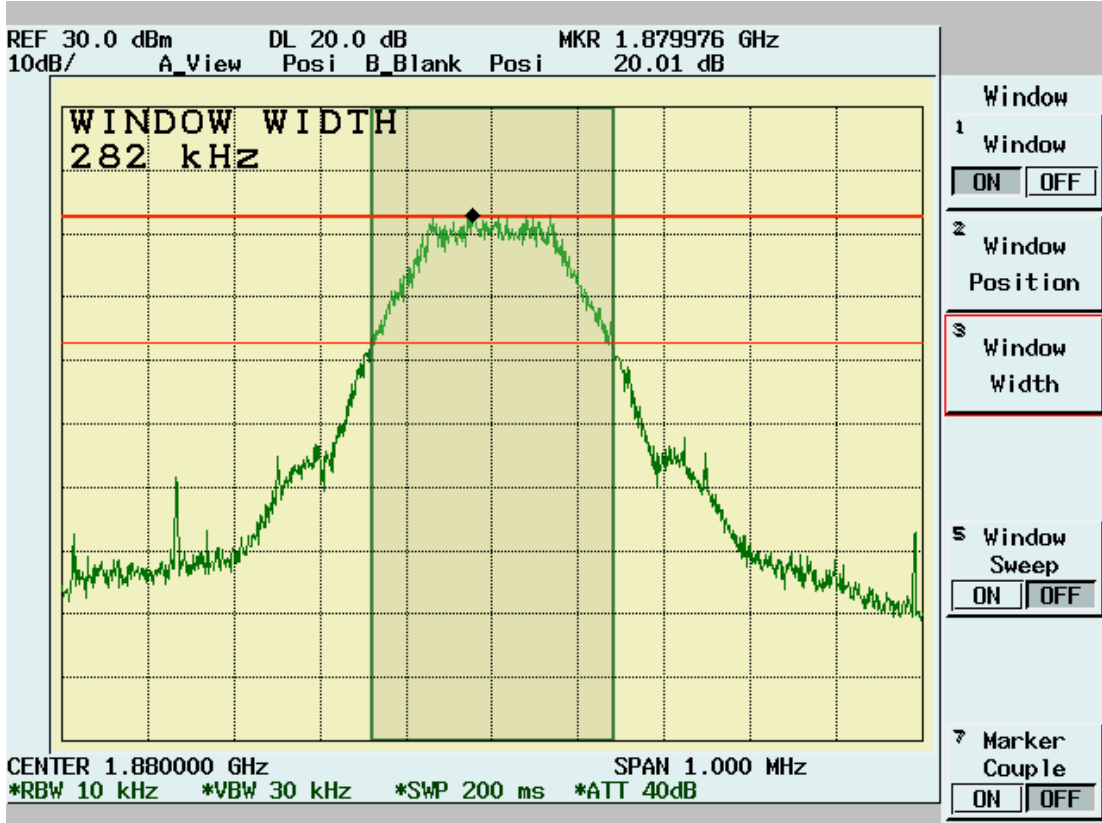

EDGE 1900 High Channel

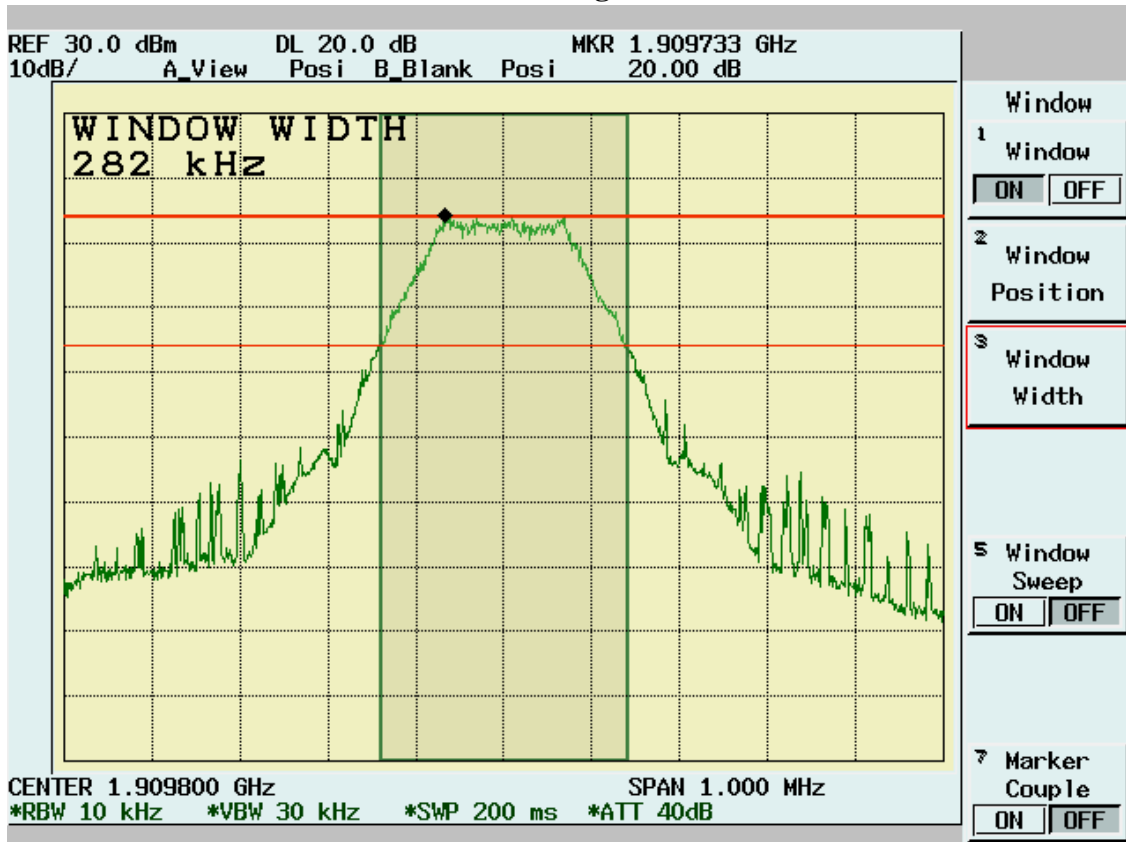

4.3 Spurious Emission At Antenna Terminals (+/-1MHz)

[Section 2.1049, 22.917, 24.238]

4.3.1 Test Procedure

1. The Transmitter output of EUT was connected to the Spectrum analyzer through the directional coupler.
2. Spectrum analyzer setting is listed below:

Channels Tested:	Cellular850: Low Channel High Channel PCS1900: Low Channel High Channel
Detector Function:	Peak Mode
Span:	5MHz
Resolution Bandwidth (RBW):	3kHz(GPRS/EDGE)
Video Bandwidth (VBW)	10kHz(GPRS/EDGE)
Sweep Time	500ms

4.3.2 Test Setup

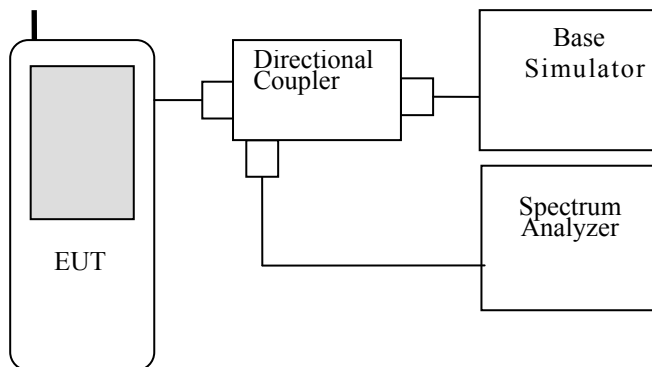

4.3.3 Test Data

GPRS 850 Low Channel

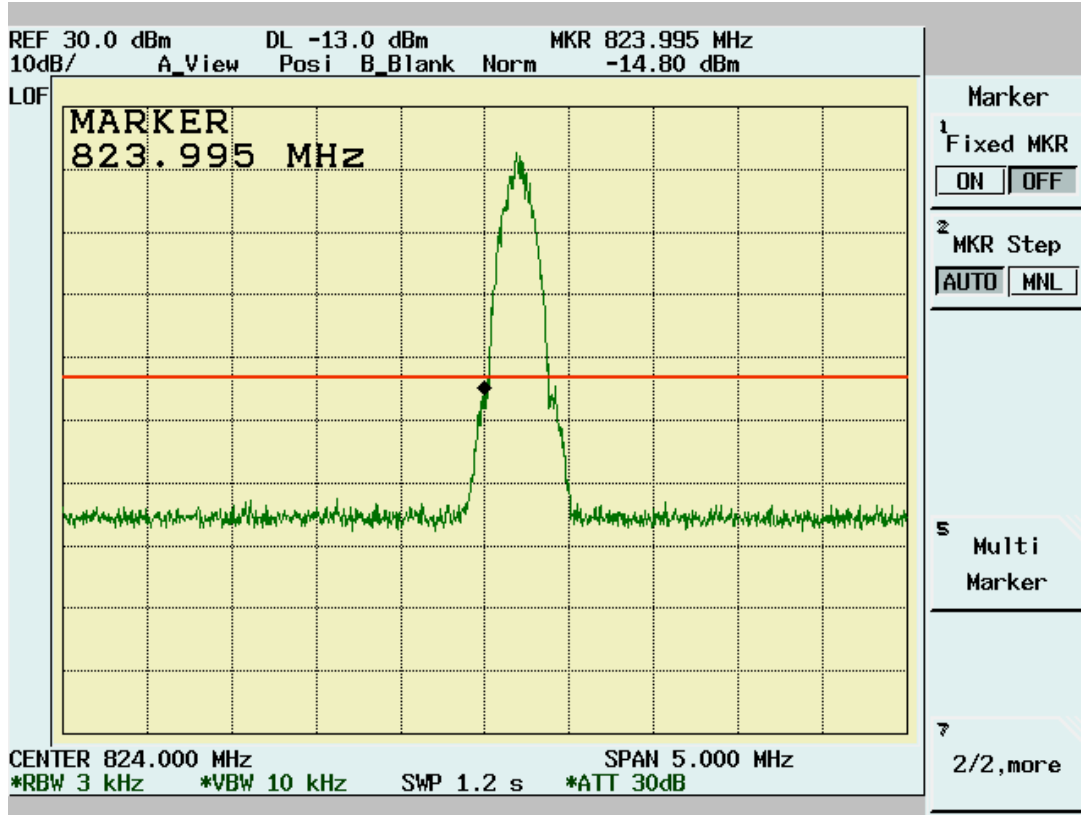

GPRS 850 High Channel

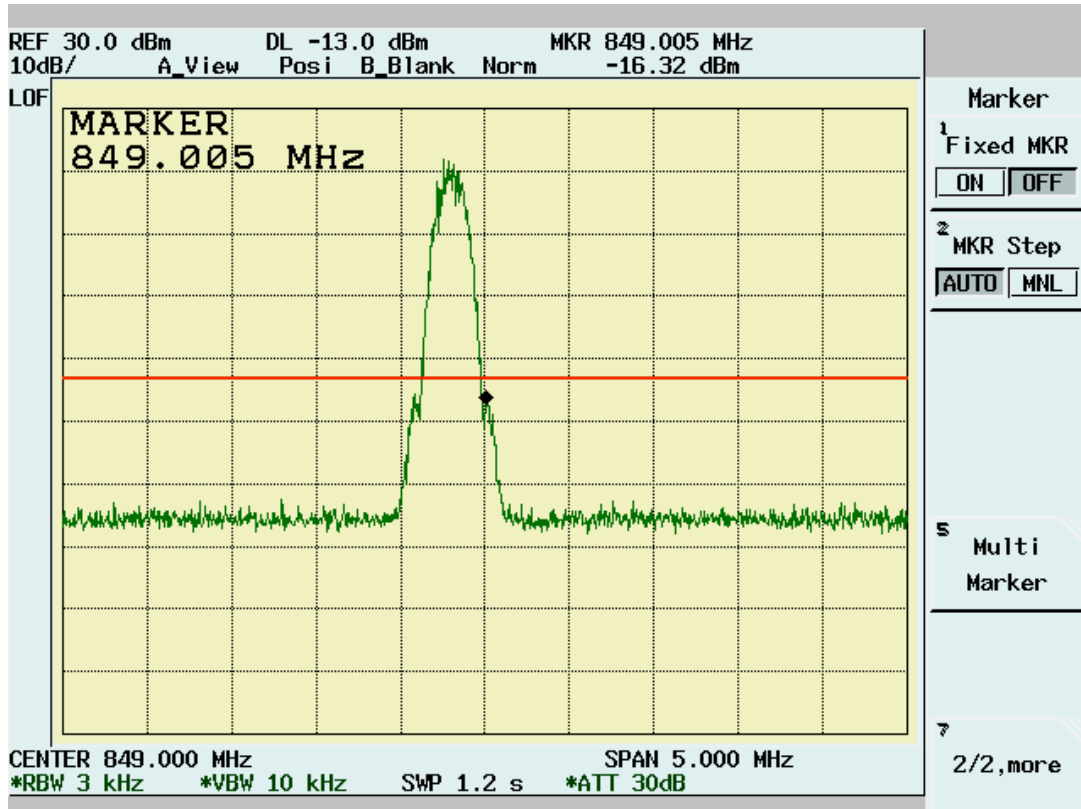

GPRS 1900 Low Channel

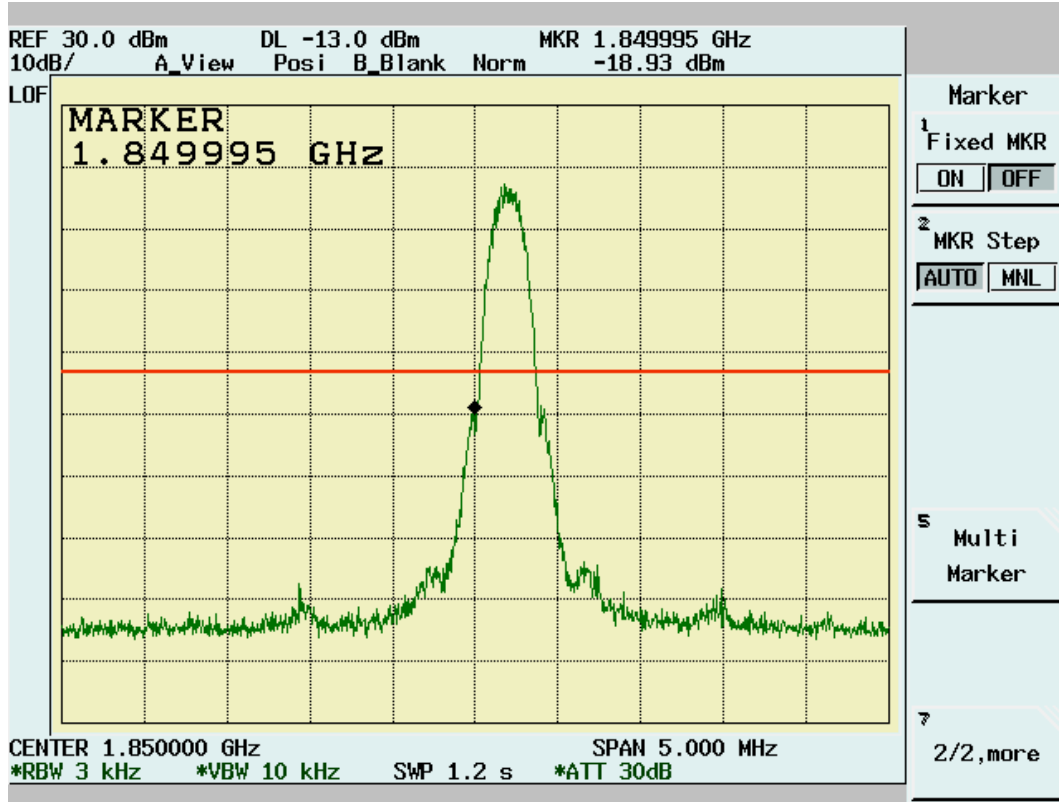

GPRS 1900 High Channel

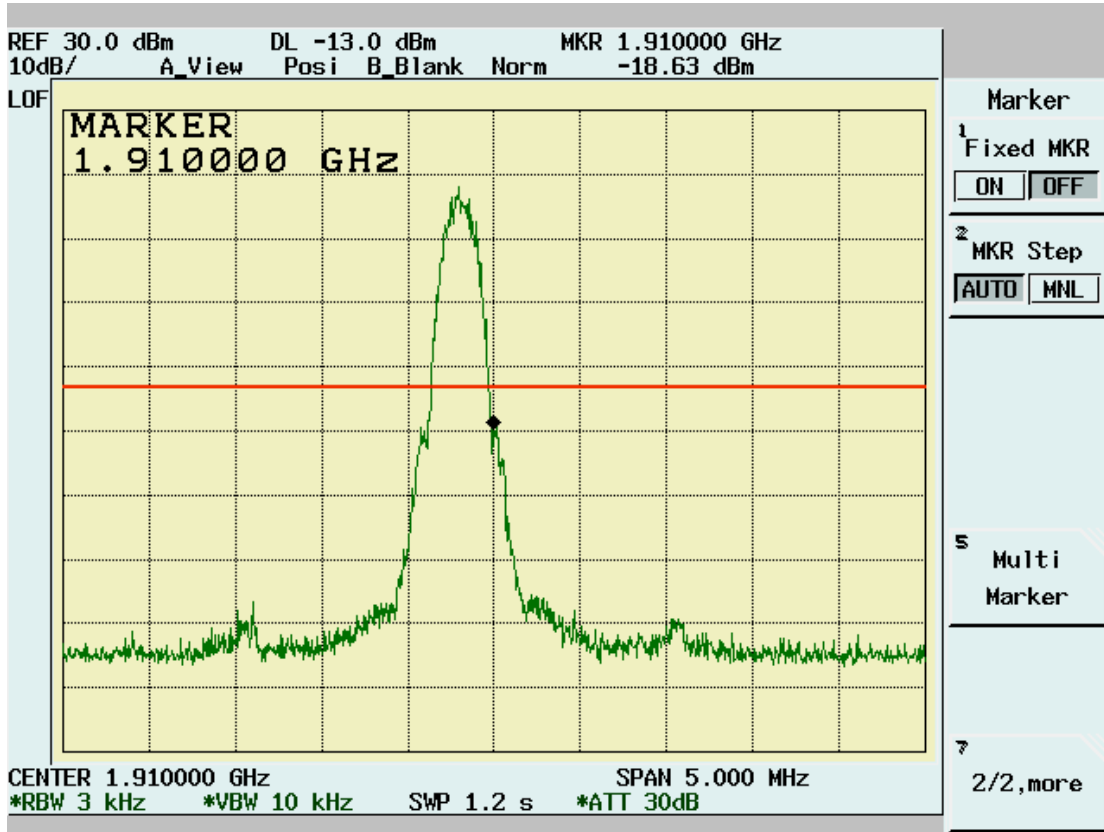

EDGE 850 Low Channel

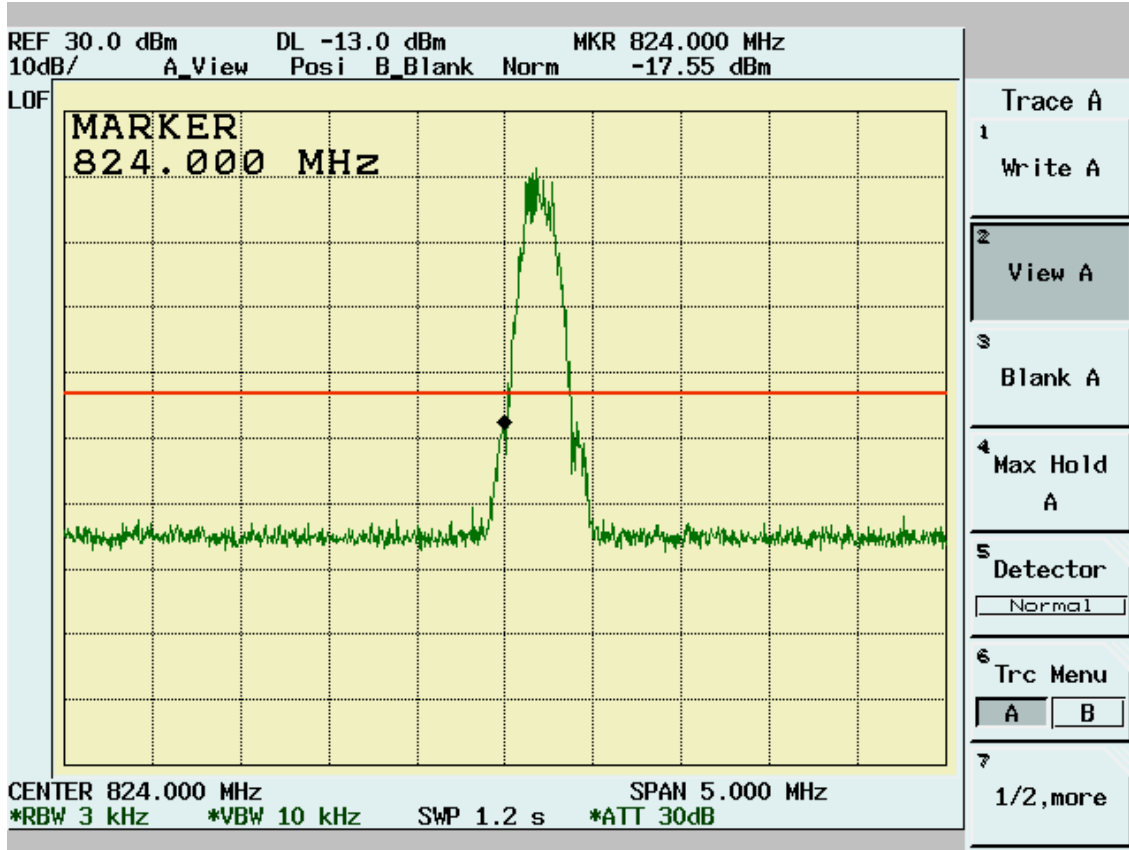

EDGE 850 High Channel

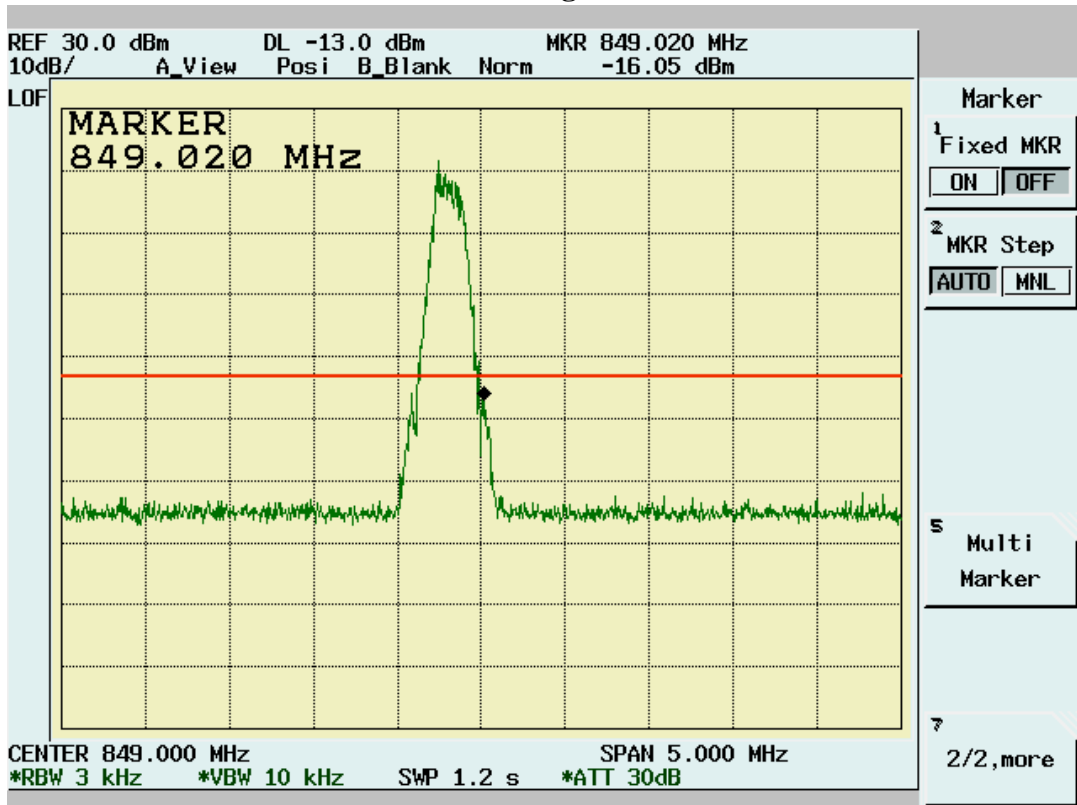

EDGE 1900 Low Channel

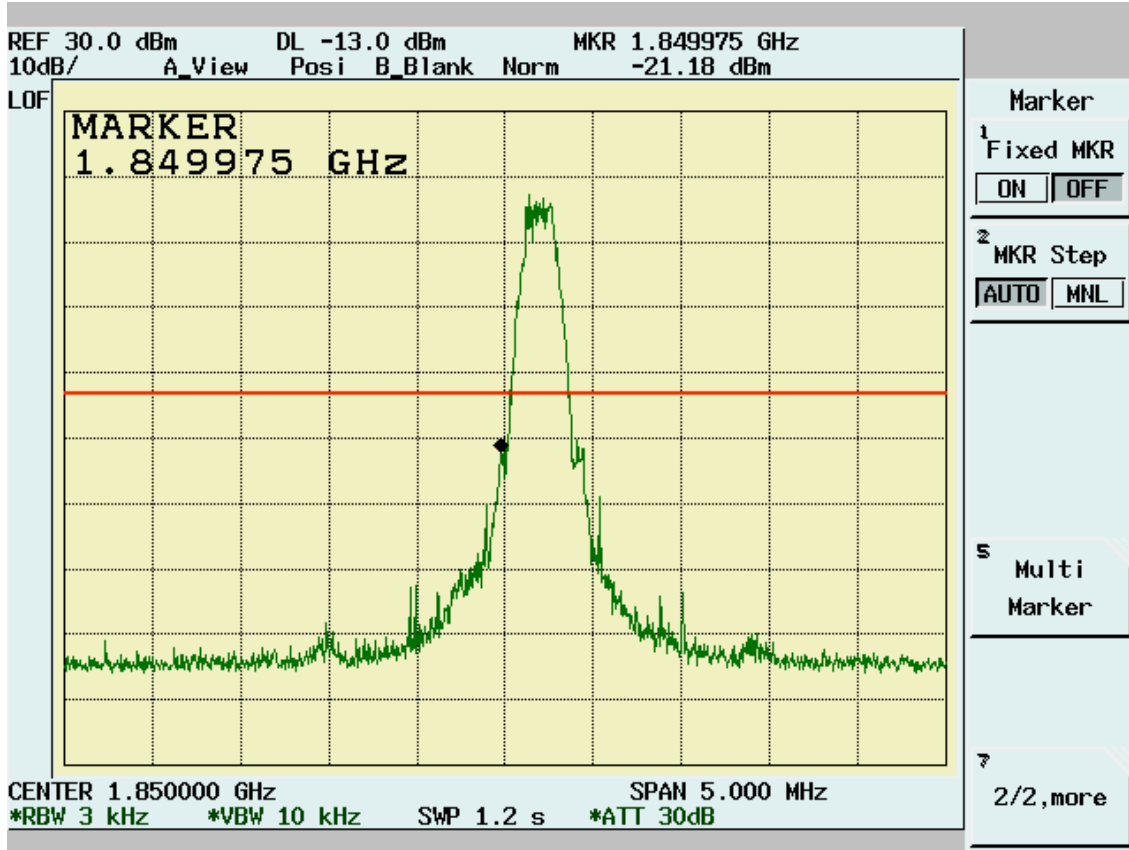

EDGE 1900 High Channel

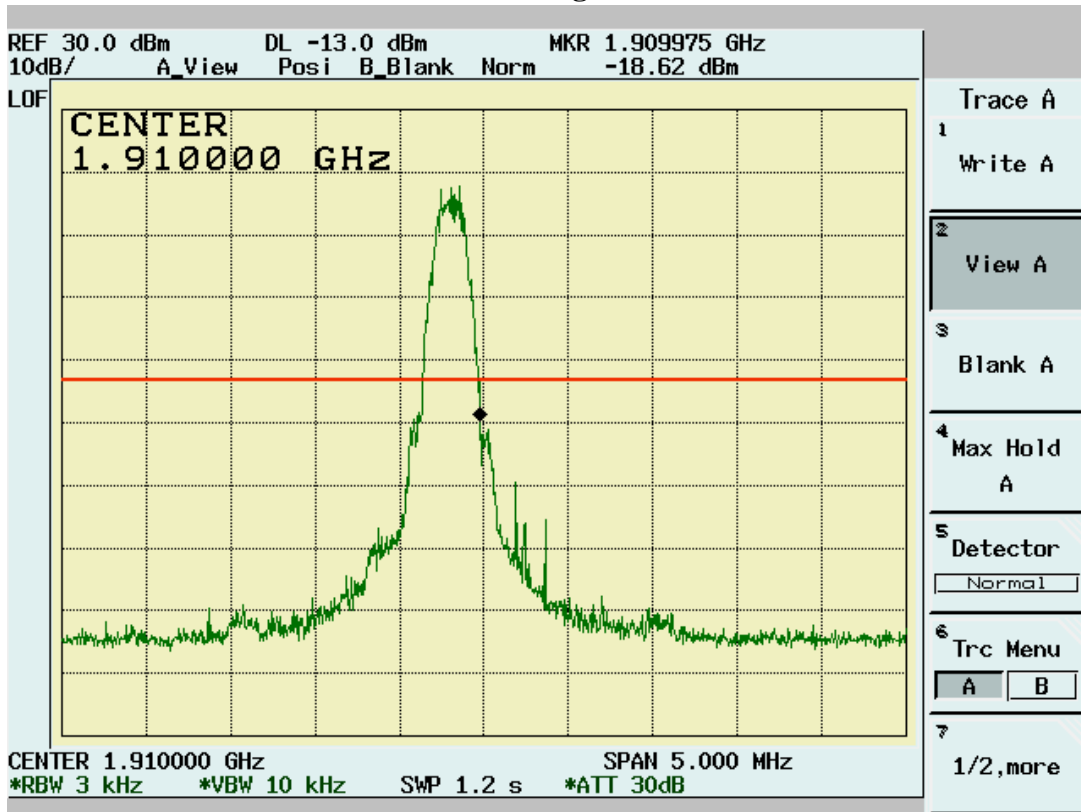

4.4 Spurious Emission Measurement [Section 2.1051,2.1053, 22.917(a), 24.238(b)]

4.4.1 Test Procedure(Conducted)

1. The Transmitter output of EUT was connected to the Spectrum analyzer through the directional coupler.
2. For the test of 2nd to 10th harmonics frequencies , the frequencies were tested using Peak mode.
3. Spectrum analyzer setting is listed below:

Channels Tested:	Cellular850: Mid. Channel PCS1900: Mid. Channel
Detector Function:	Peak Power Mode
Span:	4000MHz
Resolution Bandwidth (RBW):	1MHz
Video Bandwidth (VBW)	3MHz
Sweep Time	500ms

4.4.2 Test Procedure(Radiated)

1. The equipment under test was set up on the 10 meter chamber with measurement distance of 3 meters. The EUT was placed on a non-conductive table 80cm above ground.
2. Any changes made to the configuration, or modifications made to the EUT, during testing are noted in the following test record.

The system was set up as described above, with the EMI diagnostic software running. We found the maximum readings by varying the height of antenna and then rotating the turntable. Both polarization of antenna, horizontal and vertical, are measured.

3. 30M to 1GHz: The highest emissions between 30 MHz to 1000 MHz were also analyzed in details by operating the spectrum analyzer and/or EMI receiver in quasi-peak mode to determine the precise amplitude of the emissions. While doing so, the interconnecting cables and major parts of the system were moved around, the antenna height was varied between one and four meters, its polarization was varied between vertical and horizontal, and the turntable was slowly rotated, to maximize the emission.
4. 1GHz – 20GHz: The highest emissions were also analyzed in details by operating the spectrum analyzer and/or EMI receiver in peak mode to determine the precise amplitude of the emission. While doing so, the interconnecting cables and major parts of the system were moved around, the antenna height was varied between one and four meters, its polarization was varied between vertical and horizontal, and the turntable was slowly rotated, to maximize the emission. During test the EMI receiver and spectrum was setup according to EMI Receiver/Spectrum Analyzer Configuration.
5. For the test of 2nd to 10th harmonics frequencies, the frequencies were tested using Peak mode.

6. Spectrum analyzer setting is listed below:

Frequency Range Tested:	30MHz~1000MHz
Detector Function:	Peak Mode
Resolution Bandwidth (RBW):	120KHz
Video Bandwidth (VBW)	1MHz

Frequency Range Tested:	1GHz – 20 GHz
Detector Function:	Peak Mode
Resolution Bandwidth (RBW):	1MHz
Video Bandwidth (VBW)	3MHz

4.4.3 Test Setup

General Conducted Test Configuration

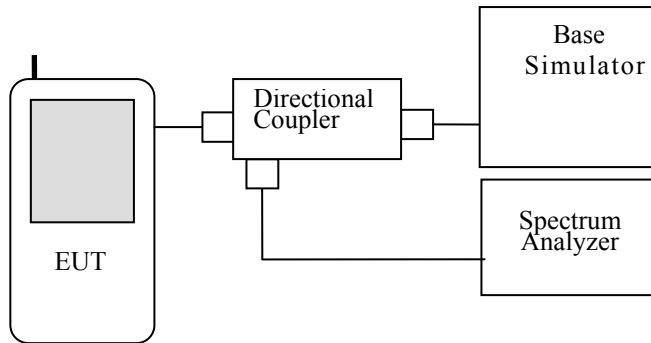

General Radiation Test Configuration

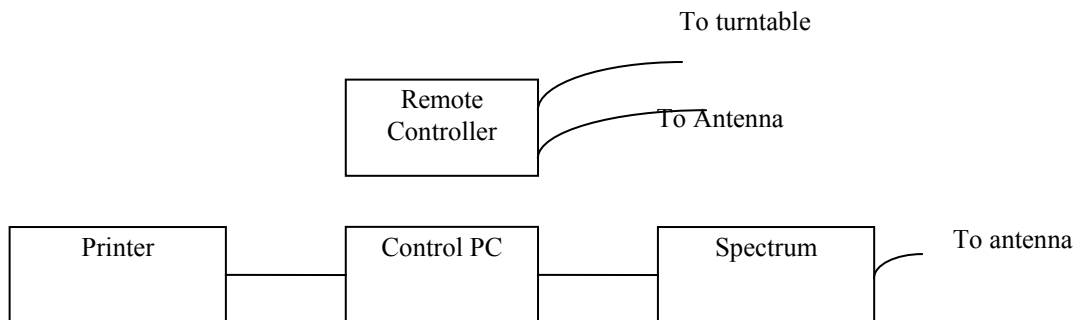
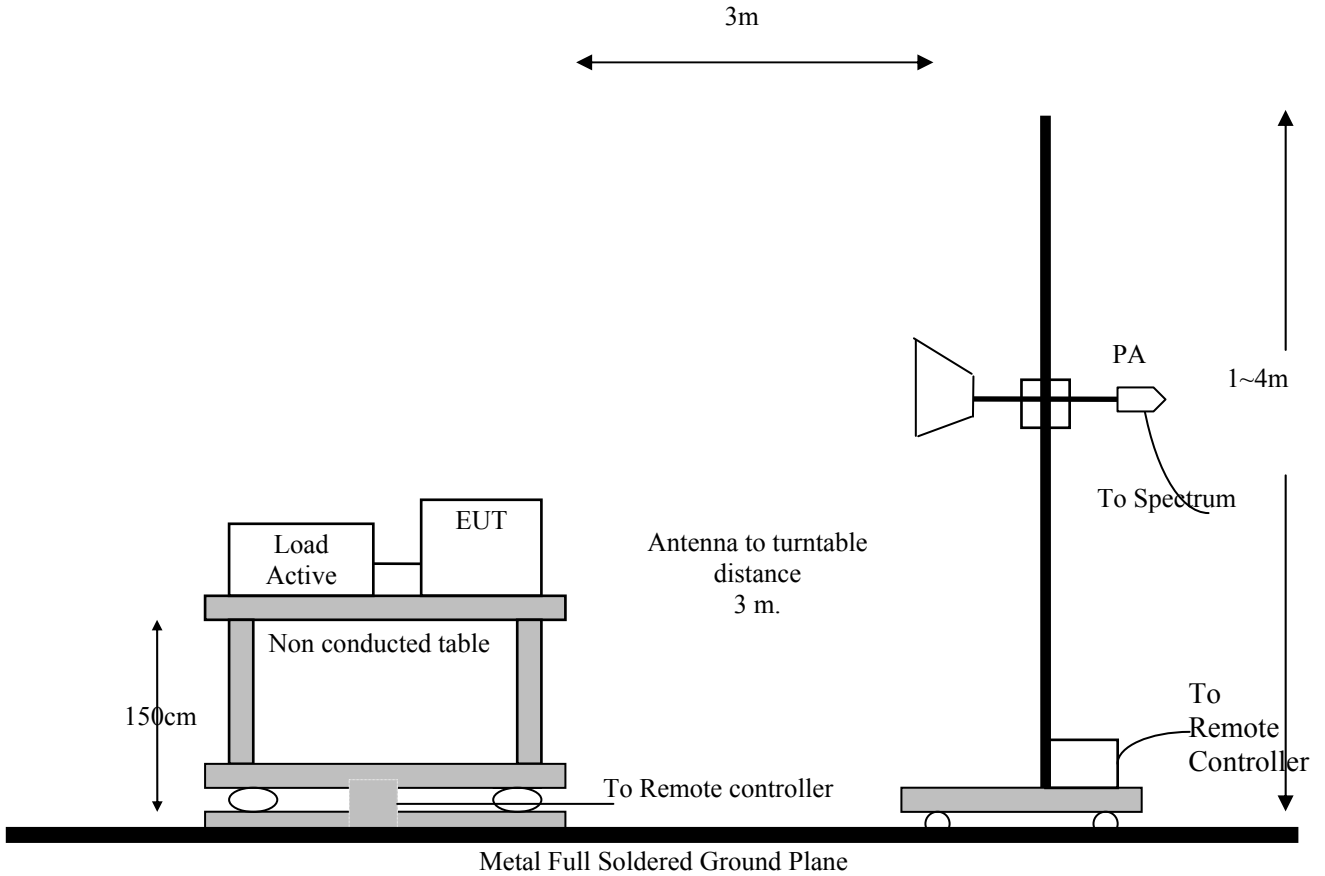

4.4.4 Conducted Test Data:

GPRS 9kHz – 10GHz Conducted Emissions Mid. Channel

Cellular850

Frequency	Reading Level	Path loss	Results	Limit	Pass/Fail
(MHz)	(dBm)	(dB)	(dBm)	(dBm)	
1670	-41.88	1.55	-40.33	-13	Pass
2510	-36.27	2.11	-34.16	-13	Pass
3345	-58.41	3.23	-55.18	-13	Pass
4180	-46.76	3.57	-43.19	-13	Pass
5015	-55.17	3.63	-51.54	-13	Pass
5859	-65.12	3.55	-61.57	-13	Pass
6696	-64.41	3.65	-60.76	-13	Pass
7528	-44.46	3.98	-40.48	-13	Pass
8364	-53.71	4.50	-49.21	-13	Pass

GPRS 9kHz – 20GHz Conducted Emissions Mid Channel

PCS1900

Frequency	Reading Level	Path loss	Results	Limit	Pass/Fail
(MHz)	(dBm)	(dB)	(dBm)	(dBm)	
3755	-50.97	1.89	-49.08	-13	Pass
5635	-53.16	3.52	-49.64	-13	Pass
6432	-59.91	3.43	-56.48	-13	Pass
7518	-60.23	3.91	-56.32	-13	Pass
9396	-56.02	4.57	-51.45	-13	Pass
11280	-60.81	4.09	-56.72	-13	Pass
13158	-56.00	3.49	-52.51	-13	Pass
15036	-58.69	4.97	-53.72	-13	Pass
16920	-65.02	4.96	-60.06	-13	Pass
18800	-66.11	5.80	-60.31	-13	Pass

4.4.5 Radiated Test Data: .

GPRS 30M – 10GHz Open Field Radiated Emissions (Horizontal) Mid. Channel

Cellular850

Frequency	Raw Results	Correction factor	Results (EIRP)	Limit	Pass/Fail
(MHz)	(dBm)	(dB)	(dBm)	(dBm)	
1672	-63.95	4.24	-59.71	-13	Pass
2508	-64.91	7.72	-57.19	-13	Pass
3345	-65.01	9.30	-55.71	-13	Pass
4180	-65.05	9.67	-55.38	-13	Pass
5015	-64.78	11.02	-53.76	-13	Pass
5859	-64.65	13.98	-50.67	-13	Pass
6696	-64.31	20.54	-43.77	-13	Pass
7528	-65.55	15.82	-49.73	-13	Pass
8364	-65.18	18.74	-46.44	-13	Pass

GPRS 30M – 10GHz Open Field Radiated Emissions (Vertical) Mid. Channel

Cellular850

Frequency	Raw Results	Correction factor	Results (EIRP)	Limit	Pass/Fail
(MHz)	(dBm)	(dB)	(dBm)	(dBm)	
1672	-60.84	4.24	-56.6	-13	Pass
2508	-59.88	7.72	-52.16	-13	Pass
3345	-64.23	9.30	-54.93	-13	Pass
4180	-64.65	9.67	-54.98	-13	Pass
5015	-65.04	11.02	-54.02	-13	Pass
5859	-64.13	13.98	-50.15	-13	Pass
6696	-65.06	20.54	-44.52	-13	Pass
7528	-64.77	15.82	-48.95	-13	Pass
8364	-64.79	18.74	-46.05	-13	Pass

GPRS 30M – 20GHz Open Field Radiated Emissions (Horizontal) Mid. Channel

PCS1900

Frequency	Raw Results	Correction factor	Results (EIRP)	Limit	Pass/Fail
(MHz)	(dBm)	(dB)	(dBm)	(dBm)	
3760	-60.42	11.04	-49.38	-13	Pass
5635	-64.24	15.30	-48.94	-13	Pass
7518	-65.09	17.84	-47.25	-13	Pass
9396	-65.13	21.64	-43.49	-13	Pass
11280	-64.07	17.48	-46.59	-13	Pass
13158	-65.09	19.83	-45.26	-13	Pass
15036	-64.99	26.01	-38.98	-13	Pass

GPRS 30M – 20GHz Open Field Radiated Emissions (Vertical) Mid. Channel

PCS1900

Frequency	Raw Results	Correction factor	Results (EIRP)	Limit	Pass/Fail
(MHz)	(dBm)	(dB)	(dBm)	(dBm)	
3760	-58.24	11.04	-47.2	-13	Pass
5635	-64.93	15.30	-49.63	-13	Pass
7518	-65.05	17.84	-47.21	-13	Pass
9396	-65.78	21.64	-44.14	-13	Pass
11280	-64.44	17.48	-46.96	-13	Pass
13158	-64.11	19.83	-44.28	-13	Pass
15036	-65.23	26.01	-39.22	-13	Pass

Note:

1. Receiver setting (Peak Detector) : RBW:1MHz; VBW:3MHz ◦
2. Correction factor = Substitution SG Level + Antenna Gain - Cable Loss – Rx. level ◦
3. ERP/EIRP Value = Raw Results + Correction factor ◦

4.5 Frequency Stability Under Temperature Variations & Voltage Variations

[Section 2.1055, 22.355, 24.235]

4.5.1 Test Procedure

1. The Temperature/Humidity Chamber was set to the specified temperature and humidity and allow sufficient time, approximately 30 minutes, to be stabilized.
2. The EUT was placed in the Temperature/Humidity Chamber and powered by a Voltage/Frequency Power converter.
3. The Transmitter output of EUT was connected to the Base Simulator
4. EUT is turned on and the operating frequency was measured after 2, 5, 10 minutes with its normal supply voltage.
5. The Voltage/Frequency Power Converter was then set to 85% and 115% of supply voltage and operating frequency was measured after 2, 5, 10 minutes.
6. The above steps were repeated for temperature of 50, 0 and -30 degree C.
7. Base Simulator setting is listed below:.

Channels Tested:	Cellular850: Low Channel Mid. Channel High Channel PCS1900: Low Channel Mid. Channel High Channel
Detector Function:	Frequency Error Mode

4.5.2 Test Setup

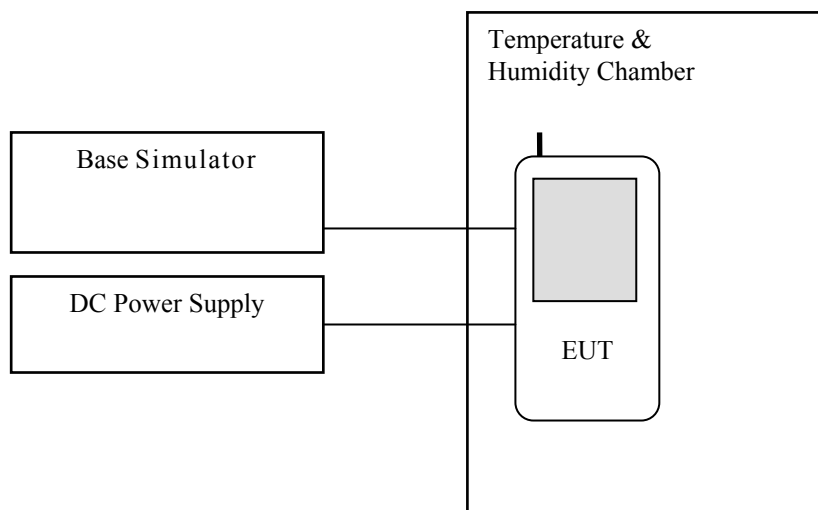

4.5.3 Test Data:

■GPRS850 Temperature Variations

Test conditions	GSM850 CH190 (836.6MHz)		
	Deviation (Hz)	limits (Hz)	Pass/fail
50°C	25	±836	Pass
40°C	33		
30°C	-47		
20°C	37		
10°C	-66		
0°C	-57		
-10°C	35		
-20°C	52		
-30°C	21		

■GPRS850 Voltage Variations

Test conditions	GSM850 CH190 (836.6MHz)		
	Deviation (Hz)	limits (Hz)	Pass/fail
16.15 V	-55	±836	Pass
19 V	-28		
21.85 V	34		

■GPRS 1900 Temperature Variations

Test conditions	GSM1900 CH661 (1880MHz)		
	Deviation (Hz)	limits (Hz)	Pass/fail
50 °C	-20	±1880	Pass
40 °C	-31		
30 °C	18		
20 °C	53		
10 °C	61		
0 °C	-44		
-10 °C	-56		
-20 °C	51		
-30 °C	37		

■GPRS1900 Voltage Variations

Test conditions	GSM1900 CH661 (1880MHz)		
	Deviation (Hz)	limits (Hz)	Pass/fail
16.15 V	-45	±1880	Pass
19 V	-39		
21.85 V	47		

5. Test Equipment

Location	Equipment Name	Brand	Model	S/N	Last Cal. Date	Next Cal. Date
Radiation	BILOG Antenna 08	Schaffner	CBL6112B	2756	06/13/2007	06/12/2008
Radiation	Coaxial Cable Chmb 02-10M	Belden	RG-8/U	Chmb 02-10M	12/28/2007	12/28/2008
Radiation	Digital Hygro-Thermometer Chmb 02	MicroLife	HT-2126G	Chmb 02	11/30/2007	12/30/2008
Radiation	EMI Receiver 03	HP	85460A	3448A00209	04/01/2007	04/01/2008
Radiation	Spectrum Analyzer 13	Advantest	R3132	121200411	02/17/2007	02/17/2008
Radiation	Horn Antenna 02	Com-Power	AH-118	10088	12/28/2007	12/27/2008
Radiation	Horn Antenna 04	Com-Power	AH-826	081-001	01/13/2007	01/13/2008
Radiation	Horn Antenna 05	Com-Power	AH-640	100A	11/16/2007	11/15/2008
Radiation	Microwave Cable RF SK-01	HUBER+SUHNERAG.	Sucoflex 102	22139 /2	11/09/2007	11/09/2008
Chamber 05	Peak Power Analyzer	HP	8990A	3621A01269	03/28/2007	03/28/2008
Chamber 05	Power Sensor Radar	HP	84815A	3318A01828	03/28/2007	03/28/2008
Radiation	Preamplifier 02	MITEQ	AFS44-00102 650-40-10P-44	728229	11/28/2007	11/28/2008
Radiation	Preamplifier 10	MITEQ	JS-26004000-2 7-5A	818471	11/22/2007	11/22/2008
Radiation	Band Reject Filter	Wainwright	WRCG 824/ 849-60/10SS	003	N/A	N/A
Radiation	Band Reject Filter	Wainwright	WRCG 1850/ 1910-60/10SS	007	N/A	N/A
Radiation	High Pass Filter 01	HEWLETT-PACKARD	84300-80038	001	N/A	N/A
Radiation	High Pass Filter 02	HEWLETT-PACKARD	84300-80039	005	N/A	N/A
Radiation	Spectrum Analyzer 14	Advantest	R3182	140600028	11/22/2007	11/22/2008

Note: Calibration is traceable to NIST or national or international standards.

6. Appendix

6.1 Appendix A: Photographs of EUT Configuration Test Set Up

Please refer to the attached file.

6.2 Appendix B: Photographs of EUT

Please refer to the attached file.