

Test Report for FCC Part 2,22&24

of

Product Name

Notebook Personal Computer

Model

W130

Applied by:

MITAC Technology Corporation
4F, No.1, R&D Road 2,
Hsinchu Science-Bas
Taiwan,R. O. C.

Test Performed by:

International Standards Laboratory

No. 120, Lane 180, San Ho Tsuen, Hsin Ho Rd.
Lung-Tan Hsiang, Tao Yuan County 325
Taiwan, R.O.C.
Tel:(03)407-1718 Fax:(03)407-1738

Report Number: ISL-06LR033FCP22

Issue Date: 2006/12/05

HC LAB: NVLAP:200234-0;VCCI: R-341,C-354; NEMKO:ELA 113A;BSMI:SL2-IN-E-0037;SL2-R1-E-0037;TAF:1178; IC:IC4067
LT LAB: NVLAP:200234-0;VCCI: R-1435,C-1440;NEMKO:ELA 113B; BSMI:SL2-IN-E-0013;TAF:0997; IC:IC4164-1

Contents of Report

1.	General.....	1
1.1	Certification of Accuracy of Test Data	1
2.	Test Results Summary.....	2
3.	Description of Equipment Under Test (EUT)	3
4.	TEST RESULTS (CDMA800/PCS1900)	4
4.1	Peak Power Output [Section 2.1046, 22.913(a), 24.232(b)]	4
4.1.1	Test Procedure(Conducted)	4
4.1.2	Test Procedure(Radiated).....	4
4.1.3	Test Setup.....	5
4.1.4	Test Data:	6
4.2	Occupied Bandwidth [Section 2.1049, 22.917(b),24.238(b)].....	8
4.2.1	Test Procedure	8
4.2.2	Test Setup.....	8
4.2.3	Test Data	9
4.3	Spurious Emission At Antenna Terminals (+/-1MHz)	12
4.3.1	Test Procedure	12
4.3.2	Test Setup.....	12
4.3.3	Test Data	13
4.4	Spurious Emission Measurement [Section 2.1051,2.1053, 22.917(a), 24.238(b)]	15
4.4.1	Test Procedure(Conducted)	15
4.4.2	Test Procedure(Radiated).....	15
4.4.3	Test Setup.....	16
4.4.4	Test Data (Conducted):	18
4.4.5	Test Data (Radiated)	19
4.5	Frequency Stability Under Temperature Variations & Voltage Variations	21
4.5.1	Test Procedure	21
4.5.2	Test Setup.....	21
4.5.3	Test Data:	22
5.	Test Equipment	24
6.	Appendix.....	25
6.1	Appendix A: Photographs of EUT Configuration Test Set Up	25
6.2	Appendix B: Photographs of EUT	25

1. General

1.1 Certification of Accuracy of Test Data

Standards: CFR 47 Part 2
CFR 47 Part 22H
CFR 47 Part 24E

Test Procedure: EIA/TIA-603A

Equipment Tested: Notebook Personal Computer

Model: W130

Applied by: MITAC Technology Corporation

Sample received Date: 2006/11/16

Final test Date : refer to the date of test data

Test Result **PASS**

Test Site: Chamber 02

Reporter: Ivy Yang

Test Engineer:

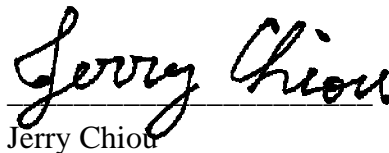
Jerry Chiou

All the tests in this report have been performed and recorded in accordance with the standards described above and performed by an independent electromagnetic compatibility consultant, International Standards Laboratory.

The test results contained in this report accurately represent the measurements of the characteristics and the energy generated by sample equipment under test at the time of the test. The sample equipment tested as described in this report is in compliance with the limits of above standards.

Approve & Signature

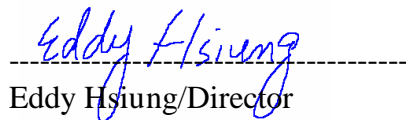
Eddy Hsiung/Director

Test results given in this report apply only to the specific sample(s) tested under stated test conditions. This report shall not be reproduced other than in full without the explicit written consent of ISL. This report totally contains 27 pages, including 1 cover page, 1 contents page, and 25 pages for the test description. This report must not be use to claim product endorsement by NVLAP or any agency of the U.S. Government.

This test data shown below is traceable to NIST or national or international standard. International Standards Laboratory certifies that no party to this application has been denied the FCC benefits pursuant to Section 5301 of the Anti-Drug Abuse Act of 1988, 21 U.S.C. 853(a).

2. Test Results Summary

The functions of EUT has been tested according to the FCC regulations listed below:

Tested Standards: 47 CFR Part 2,22&24			
Standard Section	Test Type	Result	Remarks
§2.1046 §22.913 §24.232	Peak Power Output	Pass	
§2.1049 §22.917 §24.238	Occupied Bandwidth	Pass	
§2.1049 §22.917 §24.238	Spurious Emission At Antenna Terminals (+/-1MHz)	Pass	
§2.1051 §2.1053 §22.917 §24.238	Spurious emissions	Pass	
§2.1055 §22.355 §24.235	Frequency Stability Under Temperature Variations & Voltage Variations	Pass	

3. Description of Equipment Under Test (EUT)

Product Name	Notebook Personal Computer
Model No.	W130
TX Frequency	824MHz~849MHz(CDMA800) 1850MHz ~ 1910MHz(CDMA1900)
Rx Frequency	869MHz~894MHz(CDMA800) 1930MHz ~ 1990MHz(CDMA1900)
ESN No.	602D69F3
Antenna Type	Internal
Maximum Power(conducted)	CDMA 800: 23.41 dBm CDMA 1900: 24.3 dBm
Maximum ERP/EIRP	CDMA 800(ERP): 21.09dBm CDMA 1900(EIRP): 23.61dBm
Battery Pack	DC12.6V ,
Emission designators	1M25F9W CDMA800 EUT transmitting Max. power: DC19V, 0.96A EUT idle: DC19V,0.81A
Voltage and Current in final PA	CDMA1900 EUT transmitting Max. power: DC19V, 1.0A EUT idle: DC19V,0.81A
Note	EUT does not support voice service.

4. TEST RESULTS (CDMA800/PCS1900)

4.1 Peak Power Output [Section 2.1046, 22.913(a), 24.232(b)]

4.1.1 Test Procedure(Conducted)

1. The Transmitter output of EUT was connected to the Base Simulator
2. Base Simulator setting is listed below:

Channels Tested:	Ch 1014 (824.73MHz) Ch 380 (836.4MHz) Ch 773 (848.19MHz) Ch 25 (1851.25MHz) Ch 600 (1880.0MHz) Ch 1175 (1908.75MHz)
Detector Function:	Peak Power Mode

4.1.2 Test Procedure(Radiated)

1. The equipment under test was set up on the 10 meter chamber with measurement distance of 3 meters. The EUT was placed on a non-conductive table 150cm above ground.
2. Any changes made to the configuration, or modifications made to the EUT, during testing are noted in the following test record.
3. The maximum readings by varying the height of antenna from 1~4meters and then rotating the turntable were recorded. Both polarization of antenna, horizontal and vertical with EUT' s X, Y Z axis, were measured.
4. Base Simulator setting is listed below:

Channels Tested:	Ch 1014 (824.73MHz) Ch 380 (836.4MHz) Ch 773 (848.19MHz) Ch 25 (1851.25MHz) Ch 600 (1880.0MHz) Ch 1175 (1908.75MHz)
Detector Function:	Peak Power Mode
Span:	100MHz
Resolution Bandwidth (RBW):	1MHz
Video Bandwidth (VBW)	3MHz
Sweep Time	500ms

4.1.3 Test Setup

■ General Conducted Test Configuration

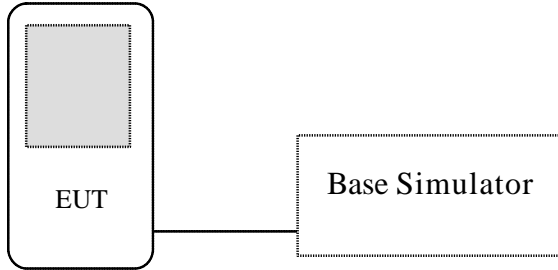

■ General Radiation Test Configuration

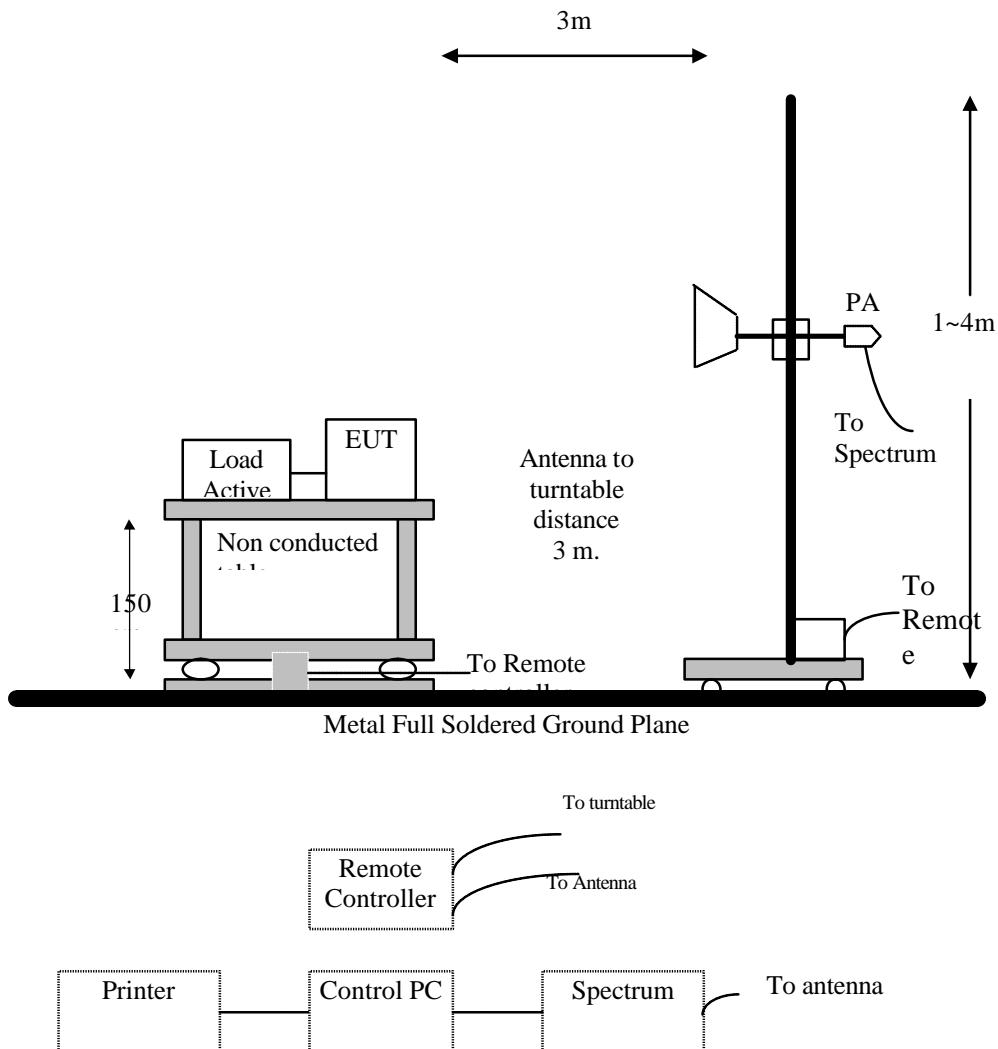

4.1.4 Test Data:

■ Maximum Peak Output Power(Conducted)

RTAP

CDMA800

Chennel	Frequency	Reading	Cable loss	Results		Limit	Pass/Fail
	(MHz)	(dBm)		(dBm)	(W)		
1014	824.73	22.43	0.8	23.23	0.21	7	Pass
380	836.40	22.54	0.8	23.34	0.215	7	Pass
773	848.19	22.61	0.8	23.41	0.219	7	Pass

■ Maximum Peak Output Power(Conducted)

RTAP

CDMA 1900

Chennel	Chennel	Reading	Cable loss	Results		Limit	Pass/Fail
		(dBm)		(dBm)	(W)		
25	25	22.49	1.5	23.99	0.25	2	Pass
600	600	22.81	1.5	24.31	0.269	2	Pass
1175	1175	22.19	1.5	23.69	0.233	2	Pass

■ Maximum Peak Output Power(Conducted)

FTAP

CDMA800

Chennel	Frequency	Reading	Cable loss	Results		Limit	Pass/Fail
	(MHz)	(dBm)		(dBm)	(W)		
1014	824.73	22.29	0.8	23.09	0.204	7	Pass
380	836.40	22.37	0.8	23.17	0.207	7	Pass
773	848.19	22.44	0.8	23.24	0.211	7	Pass

■ Maximum Peak Output Power(Conducted)

FTAP

CDMA 1900

Chennel	Chennel	Reading	Cable loss	Results		Limit	Pass/Fail
		(dBm)		(dBm)	(W)		
25	25	22.31	1.5	23.81	0.240	2	Pass
600	600	22.5	1.5	24.00	0.251	2	Pass
1175	1175	22.08	1.5	23.58	0.228	2	Pass

■ **Maximum Peak Output Power(Radiated)**

CDMA800

Chennel	Frequency (MHz)	Raw Results (dBm)	Correction factor (dB)	Results (ERP)		Limit (W)	Pass/Fail
				(dBm)	(mW)		
1014	824.2	-12.16	32.04	19.88	97.27	7	Pass
380	836.4	-11.90	32.04	20.14	103.3	7	Pass
773	848.8	-10.95	32.04	21.09	128.5	7	Pass

■ **Maximum Peak Output Power(Radiated)**

CDMA 1900

Chennel	Chennel	Raw Results (dBm)	Correction factor (dB)	Results (EIRP)		Limit (W)	Pass/Fail
				(dBm)	(mW)		
25	824.2	-16.1	39.71	23.61	229.61	2	Pass
600	836.4	-16.37	39.71	23.34	215.77	2	Pass
1175	848.8	-19.32	39.71	20.39	109.39	2	Pass

Note:

1. Receiver setting (Peak Detector) : RBW:1MHz; VBW:3MHz。
2. Correction factor = Substitution SG Level + Antenna Gain - Cable Loss – Rx. level。
3. ERP/EIRP Value = Raw Results + Correction factor。

4.2 Occupied Bandwidth [Section 2.1049, 22.917(b),24.238(b)]

4.2.1 Test Procedure

1. The Transmitter output of EUT was connected to the Spectrum analyzer through the directional coupler.
2. Spectrum analyzer setting is listed below:

Channels Tested:	Ch 1014 (824.73MHz) Ch 380 (836.4MHz) Ch 773 (848.19MHz) Ch 25 (1851.25MHz) Ch 600 (1880.0MHz) Ch 1175 (1908.75MHz)
Detector Function:	Peak Mode
Span:	1MHz
Resolution Bandwidth (RBW):	3kHz
Video Bandwidth (VBW)	10kHz
Sweep Time	500ms

4.2.2 Test Setup

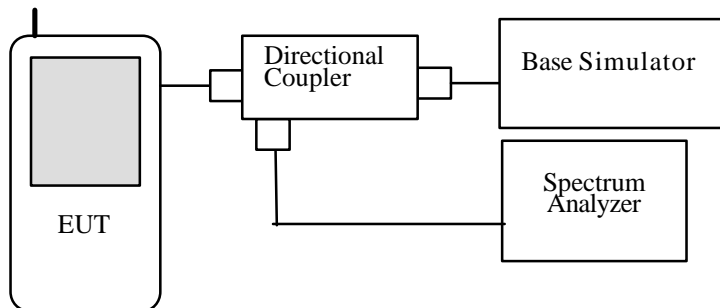

4.2.3 Test Data

CDMA 800 CH1014

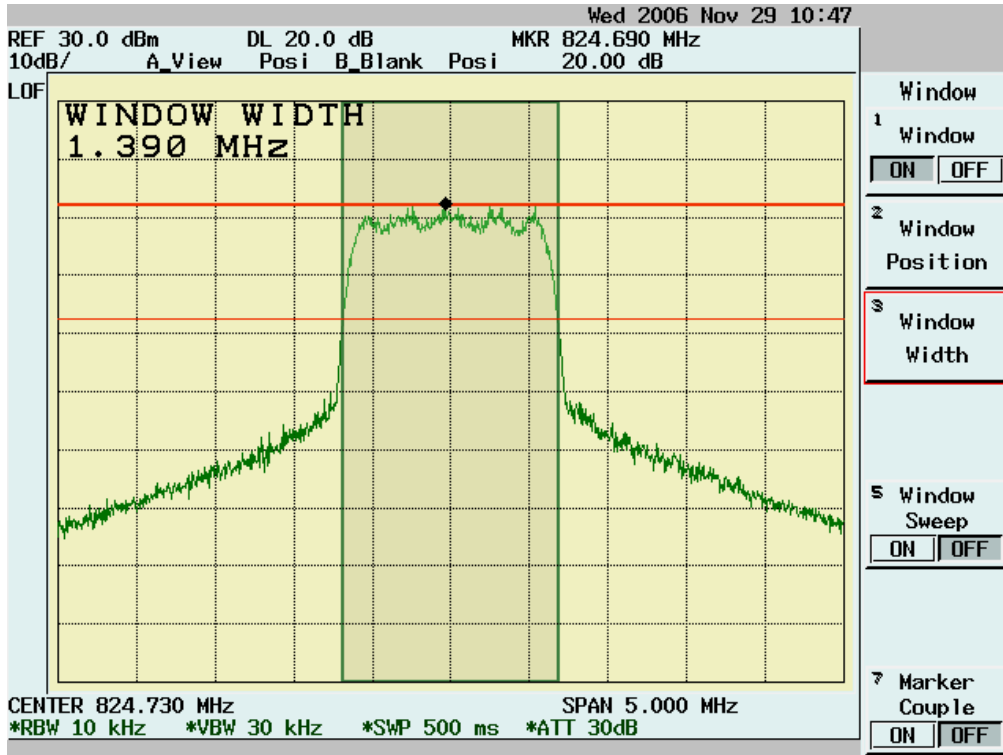

CDMA 800 CH380

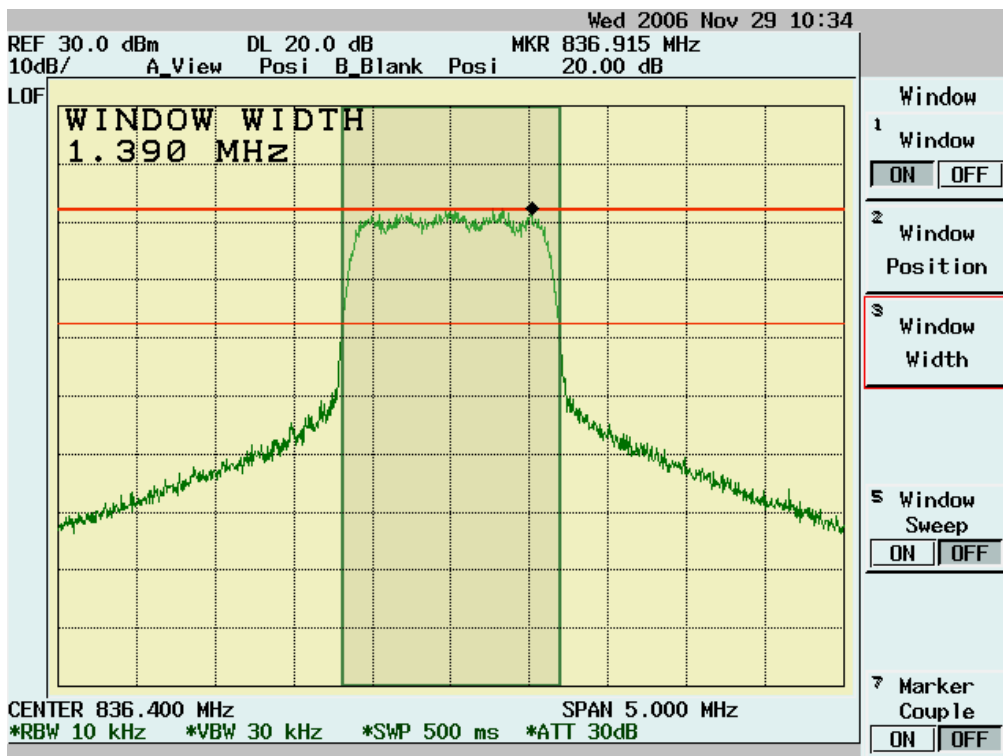

CDMA 800 CH773

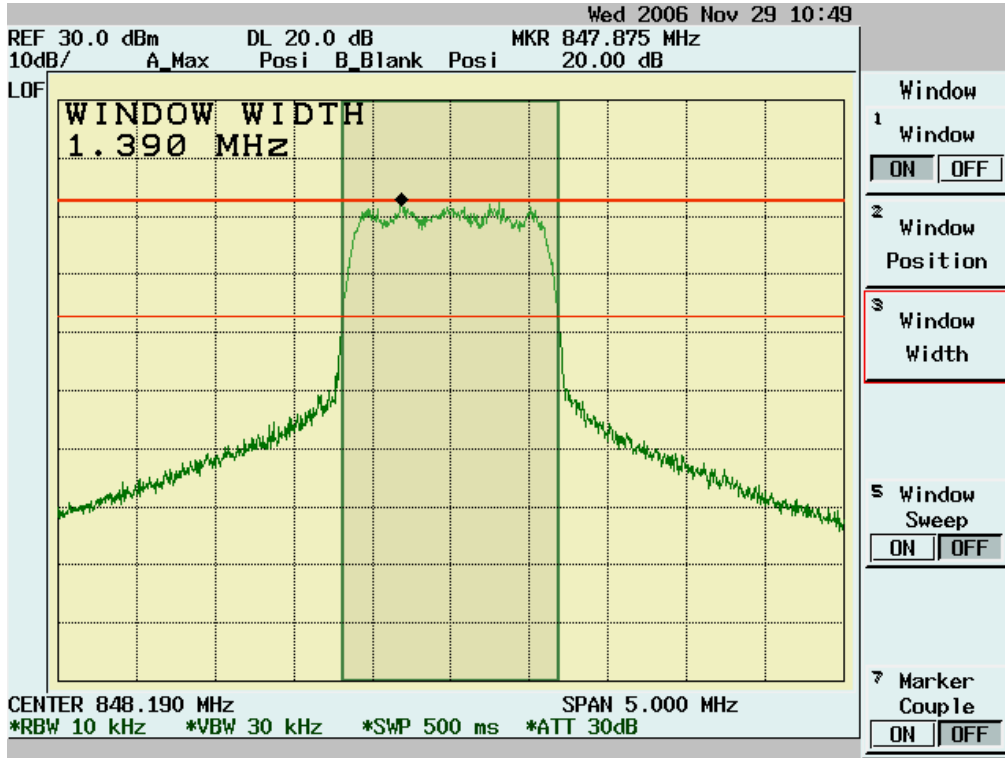

CDMA 1900 CH25

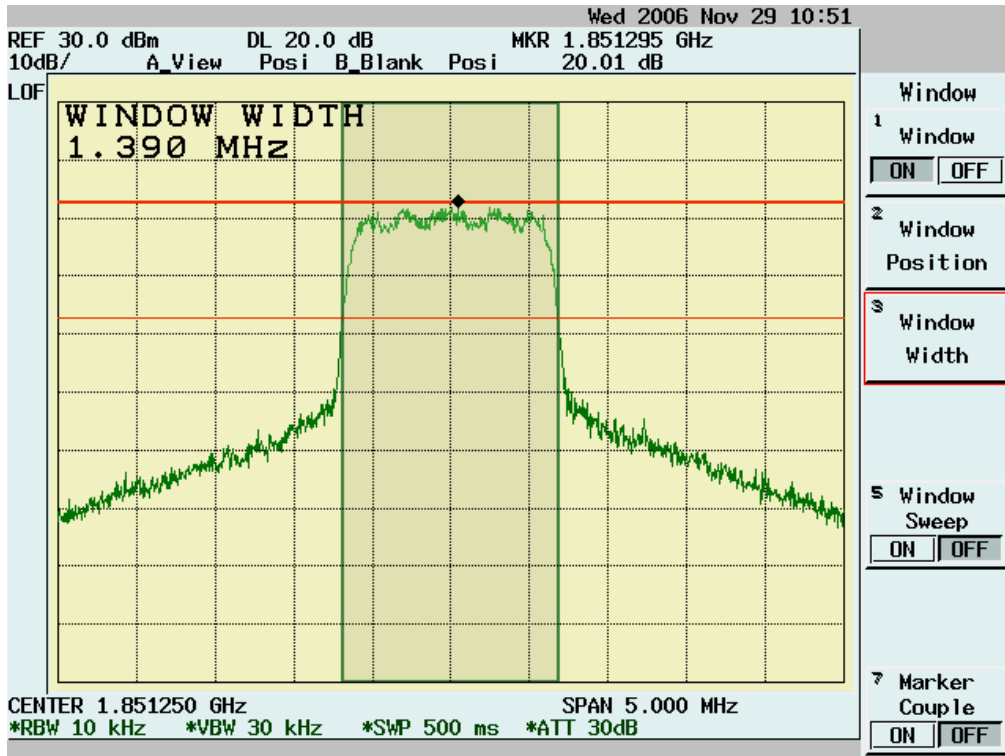

CDMA 1900 CH600

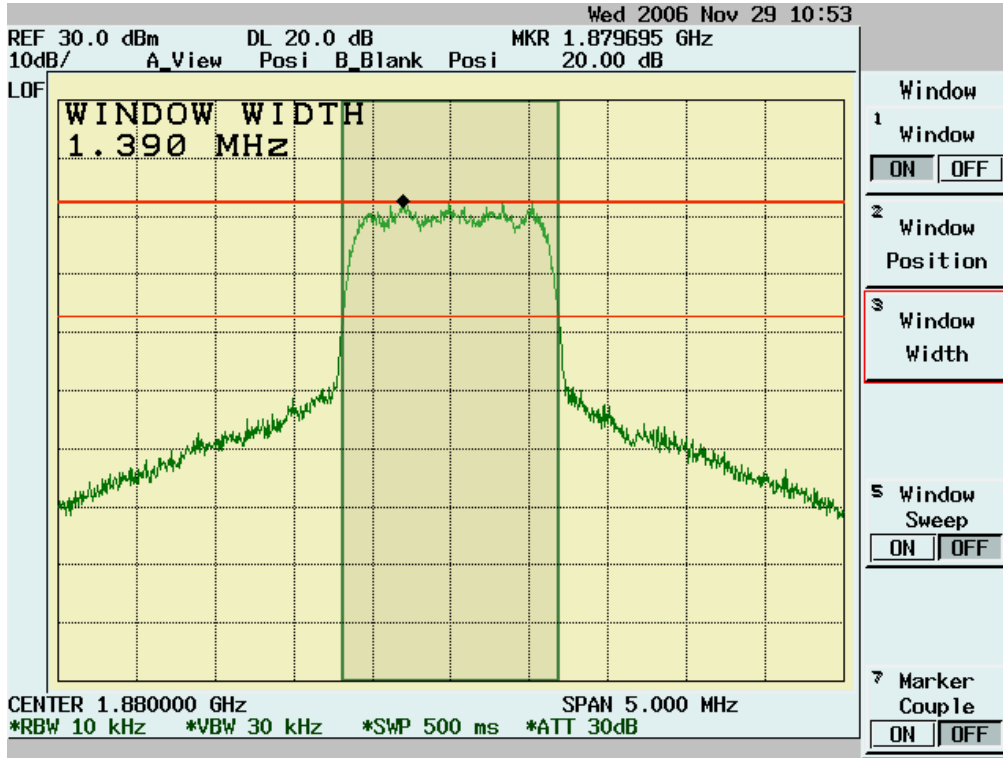

CDMA 1900 CH1175

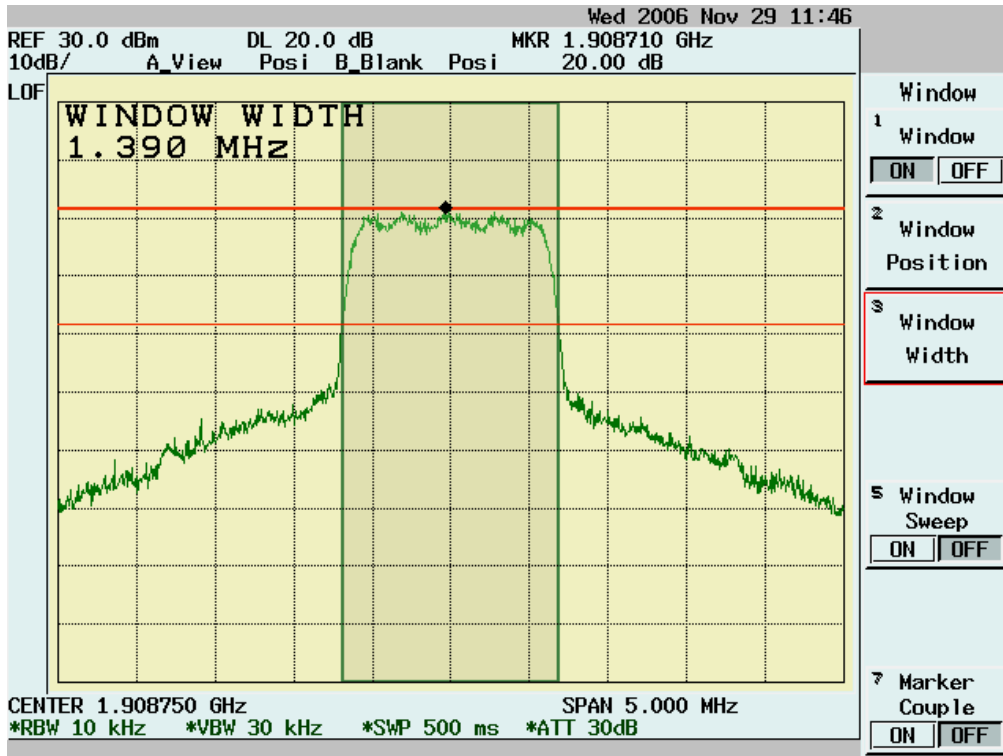

4.3 Spurious Emission At Antenna Terminals (+/-1MHz)

[Section 2.1049, 22.917, 24.238]

4.3.1 Test Procedure

1. The Transmitter output of EUT was connected to the Spectrum analyzer through the directional coupler.
2. Spectrum analyzer setting is listed below:

Channels Tested:	CDMA800: Low Ch 1014 (824.73MHz) High Ch 773 (848.19MHz) CDMA1900: Low Ch 25 (1851.25MHz) High Ch 1175 (1908.75MHz)
Detector Function:	Peak Mode
Span:	5MHz
Resolution Bandwidth (RBW):	10kHz
Video Bandwidth (VBW)	30kHz
Sweep Time	500ms

4.3.2 Test Setup

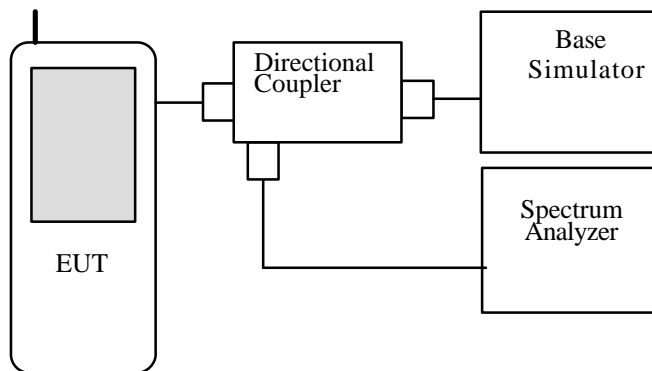

4.3.3 Test Data

CDMA 800 CH1014

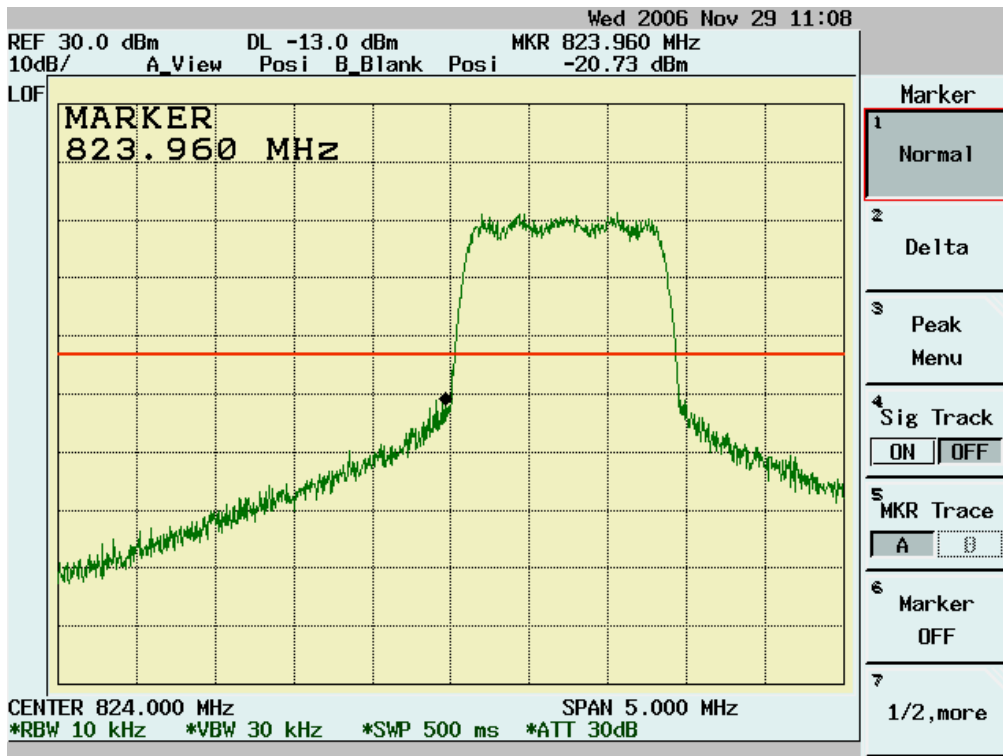

CDMA 800 CH773

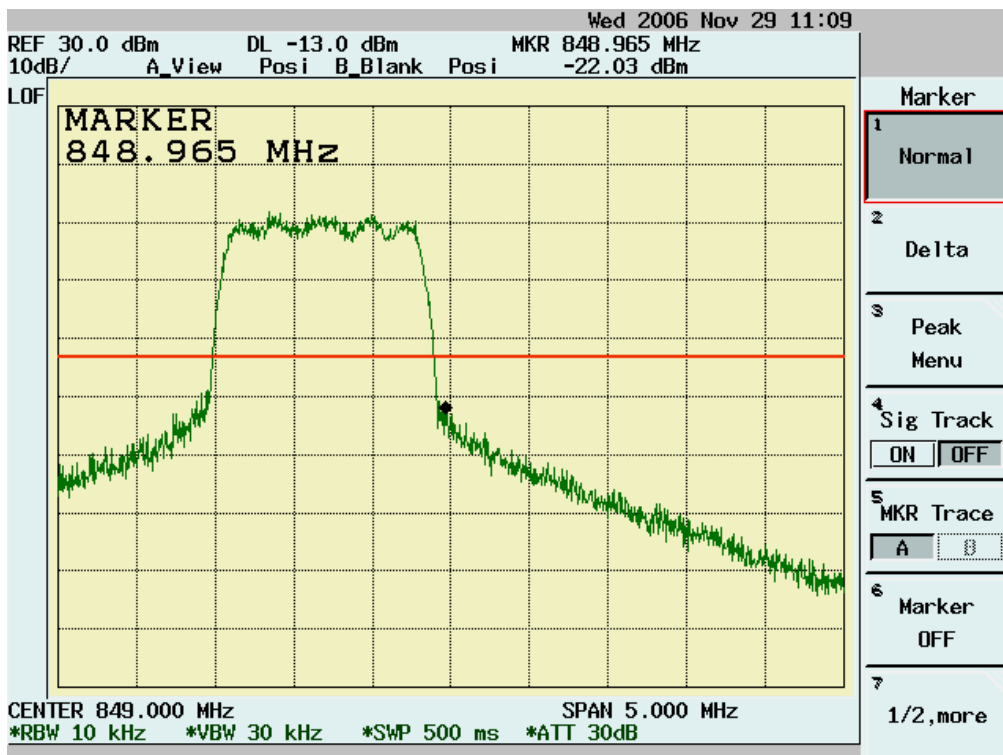

CDMA 1900 CH25

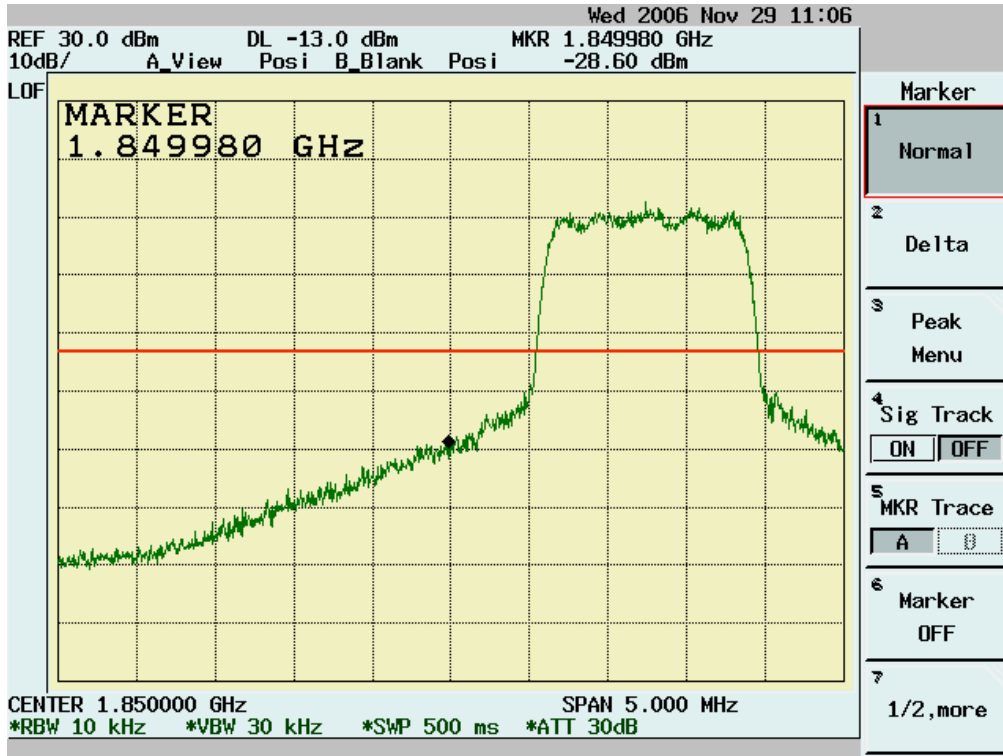

CDMA 1900 CH1175

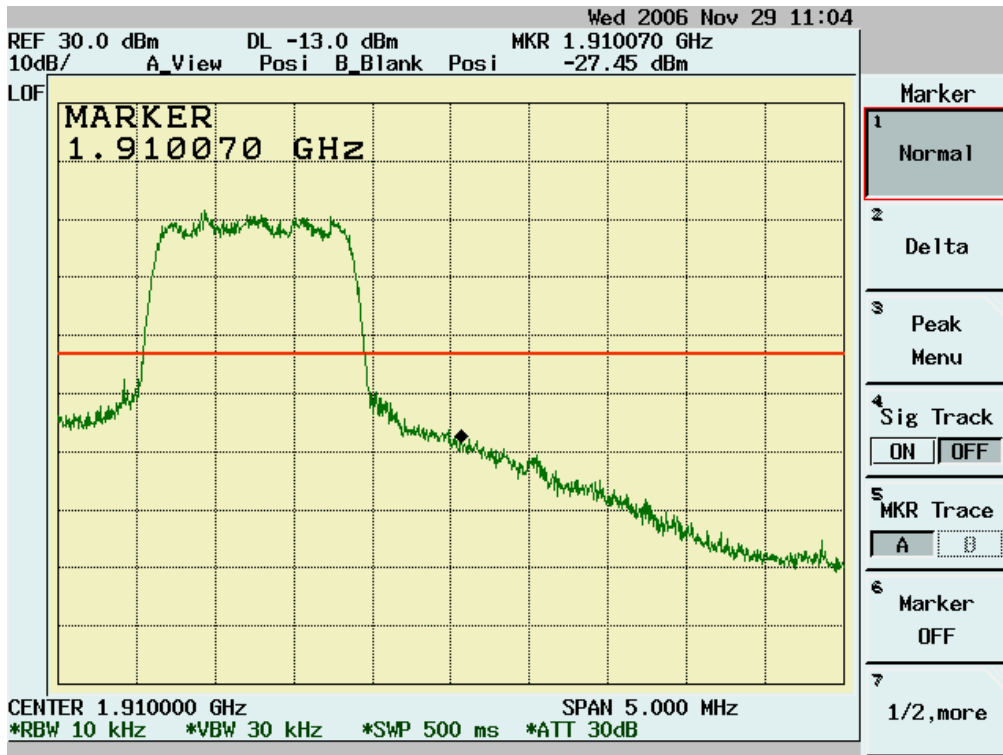

4.4 Spurious Emission Measurement [Section 2.1051,2.1053, 22.917(a), 24.238(b)]

4.4.1 Test Procedure(Conducted)

1. The Transmitter output of EUT was connected to the Spectrum analyzer through the directional coupler.
2. For the test of 2nd to 10th harmonics frequencies , the frequencies were tested using Peak mode.
3. Spectrum analyzer setting is listed below:

Channels Tested:	CDMA800: Ch 380 (836.4MHz) CDMA1900: Ch 600 (1880.0MHz)
Detector Function:	Peak Power Mode
Span:	4000MHz
Resolution Bandwidth (RBW):	1MHz
Video Bandwidth (VBW)	3MHz
Sweep Time	500ms

4.4.2 Test Procedure(Radiated)

1. The equipment under test was set up on the 10 meter chamber with measurement distance of 3 meters. The EUT was placed on a non-conductive table 80cm above ground.
2. Any changes made to the configuration, or modifications made to the EUT, during testing are noted in the following test record.

The system was set up as described above, with the EMI diagnostic software running. We found the maximum readings by varying the height of antenna and then rotating the turntable. Both polarization of antenna, horizontal and vertical, are measured.

3. 30M to 1GHz: The highest emissions between 30 MHz to 1000 MHz were also analyzed in details by operating the spectrum analyzer and/or EMI receiver in quasi-peak mode to determine the precise amplitude of the emissions. While doing so, the interconnecting cables and major parts of the system were moved around, the antenna height was varied between one and four meters, its polarization was varied between vertical and horizontal, and the turntable was slowly rotated, to maximize the emission.
4. 1GHz – 20GHz: The highest emissions were also analyzed in details by operating the spectrum analyzer and/or EMI receiver in peak mode to determine the precise amplitude of the emission. While doing so, the interconnecting cables and major parts of the system were moved around, the antenna height was varied between one and four meters, its polarization was varied between vertical and horizontal, and the turntable was slowly rotated, to maximize the emission. During test the EMI receiver and spectrum was setup according to EMI Receiver/Spectrum Analyzer Configuration.
5. For the test of 2nd to 10th harmonics frequencies, the frequencies were tested using Peak mode.

6. Spectrum analyzer setting is listed below:

Frequency Range Tested:	30MHz~1000MHz
Detector Function:	Peak Mode
Resolution Bandwidth (RBW):	120KHz
Video Bandwidth (VBW)	1MHz

Frequency Range Tested:	1GHz – 20 GHz
Detector Function:	Peak Mode
Resolution Bandwidth (RBW):	1MHz
Video Bandwidth (VBW)	3MHz

4.4.3 Test Setup

General Conducted Test Configuration

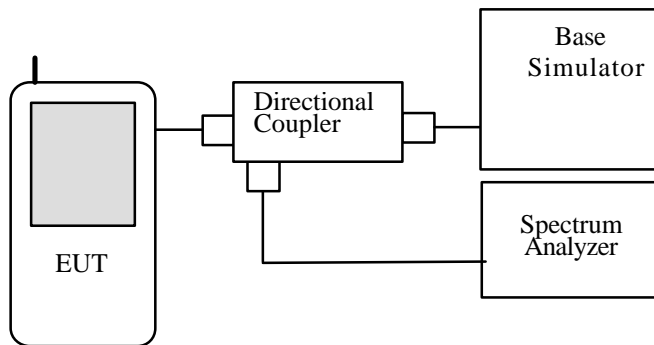

General Radiation Test Configuration

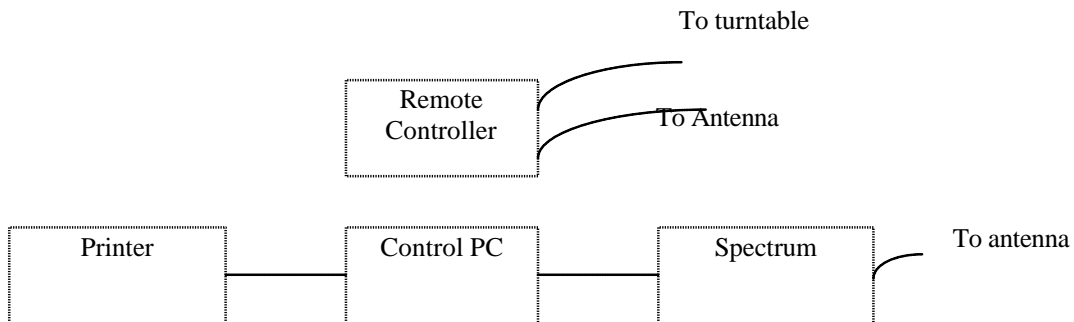
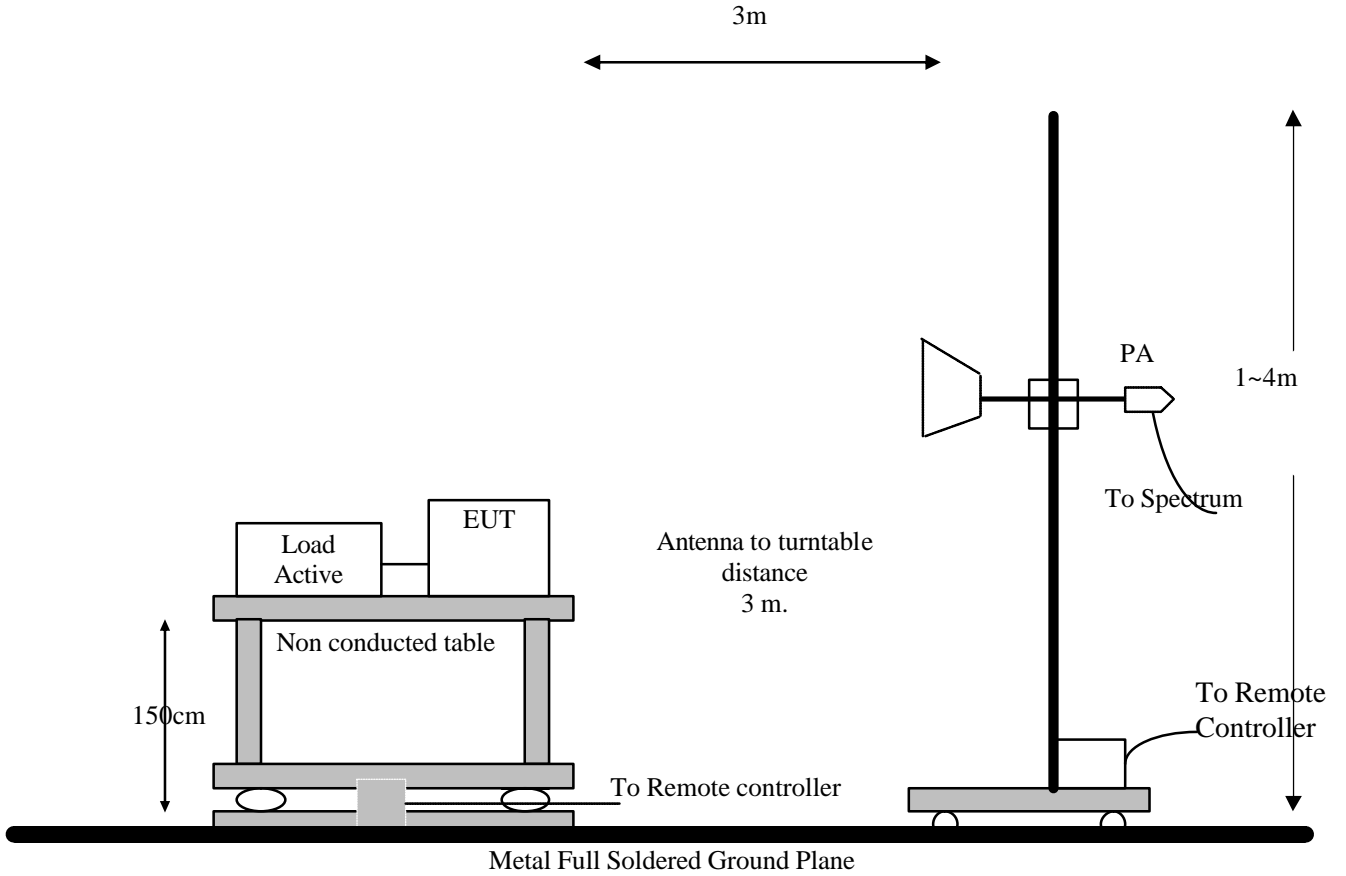

4.4.4 Test Data (Conducted):

CDMA

9kHz – 10GHz Conducted Emissions Channel 380

CDMA800

Frequency	Reading Level	Path loss	Results	Limit	Pass/Fail
(MHz)	(dBm)	(dB)	(dBm)	(dBm)	
1672	-58.49	1.55	-53.79	-13	Pass
2508	-62.45	2.11	-60.34	-13	Pass
3334	-56.17	3.23	-52.94	-13	Pass
4197	-62.98	3.57	-59.41	-13	Pass
6738	-62.98	3.55	-59.43	-13	Pass

9kHz – 20GHz Conducted Emissions Channel 600

CDMA1900

Frequency	Reading Level	Path loss	Results	Limit	Pass/Fail
(MHz)	(dBm)	(dB)		(dBm)	
3579	-50.2	3.23	-46.97	-13	Pass
5640	-63.58	3.57	-60.21	-13	Pass
7851	-52.77	3.63	-49.14	-13	Pass
15032	-63.22	4.97	-58.25	-13	Pass
16912	-62.98	4.96	-58.02	-13	Pass

4.4.5 Test Data (Radiated)

30M – 10GHz Open Field Radiated Emissions (Horizontal) Channel 380

CDMA 800

Frequency	Raw Results	Correction factor	Results (ERP)	Limit	Pass/Fail
(MHz)	(dBm)	(dB)	(dBm)	(dBm)	
1840	-61.09	4.24	-56.82	-13	Pass
2508	-60.74	7.72	-53.02	-13	Pass
3345	-64.89	9.30	-55.59	-13	Pass
4248	-65.48	9.67	-55.81	-13	Pass
6572	-62.79	11.02	-51.07	-13	Pass

30M – 10GHz Open Field Radiated Emissions (Vertical) Channel 380

CDMA 800

Frequency	Raw Results	Correction factor	Results (ERP)	Limit	Pass/Fail
(MHz)	(dBm)	(dB)	(dBm)	(dBm)	
1672	-59.59	4.24	-55.35	-13	Pass
2508	-61.48	7.72	-53.67	-13	Pass
3345	-63.21	9.30	-53.91	-13	Pass
4182	-63.41	9.67	-53.74	-13	Pass
6724	-62.58	11.02	-51.56	-13	Pass

Note:

1. Receiver setting (Peak Detector) : RBW:1MHz; VBW:3MHz。
2. Correction factor = Substitution SG Level + Antenna Gain - Cable Loss – Rx. level。
3. ERP/EIRP Value = Raw Results + Correction factor。

30M – 20GHz Open Field Radiated Emissions (Horizontal) Channel 600

CDMA 1900

Frequency	Raw Results	Correction factor	Results (EIRP)	Limit	Pass/Fail
(MHz)	(dBm)	(dB)	(dBm)	(dBm)	
3759	-61.23	11.04	-50.19	-13	Pass
5637	-61.02	15.30	-45.72	-13	Pass
7518	-62.57	17.84	44.73	-13	Pass
11798	-61.27	21.64	-39.63	-13	Pass
12544	61.72	17.48	-44.24	-13	Pass

30M – 20GHz Open Field Radiated Emissions (Vertical) Channel 600

CDMA 1900

Frequency	Raw Results	Correction factor	Results (EIRP)	Limit	Pass/Fail
(MHz)	(dBm)	(dB)	(dBm)	(dBm)	
3759	-51.42	11.04	-40.38	-13	Pass
5637	-54.73	15.30	-39.43	-13	Pass
7518	-61.5	17.84	-43.74	-13	Pass
9408	-65.41	21.64	-43.77	-13	Pass
12608	-62.15	17.48	-44.67	-13	Pass

Note:

1. Receiver setting (Peak Detector) : RBW:1MHz; VBW:3MHz.
2. Correction factor = Substitution SG Level + Antenna Gain - Cable Loss – Rx. level.
3. ERP/EIRP Value = Raw Results + Correction factor.

4.5 Frequency Stability Under Temperature Variations & Voltage Variations

[Section 2.1055, 22.355, 24.235]

4.5.1 Test Procedure

1. The Temperature/Humidity Chamber was set to the specified temperature and humidity and allow sufficient time, approximately 30 minutes, to be stabilized.
2. The EUT was placed in the Temperature/Humidity Chamber and powered by a Voltage/Frequency Power converter.
3. The Transmitter output of EUT was connected to the Base Simulator
4. EUT is turned on and the operating frequency was measured after 2, 5, 10 minutes with its normal supply voltage.
5. The Voltage/Frequency Power Converter was then set to 85% and 115% of supply voltage and operating frequency was measured after 2, 5, 10 minutes.
6. The above steps were repeated for temperature of 50, 0 and -30 degree C.
7. Base Simulator setting is listed below:.

Channels Tested:	Ch 1014 (824.73MHz) Ch 380 (836.4MHz) Ch 773 (848.19MHz) Ch 25 (1851.25MHz) Ch 600 (1880.0MHz) Ch 1175 (1908.75MHz)
Detector Function:	Frequency Error Mode

4.5.2 Test Setup

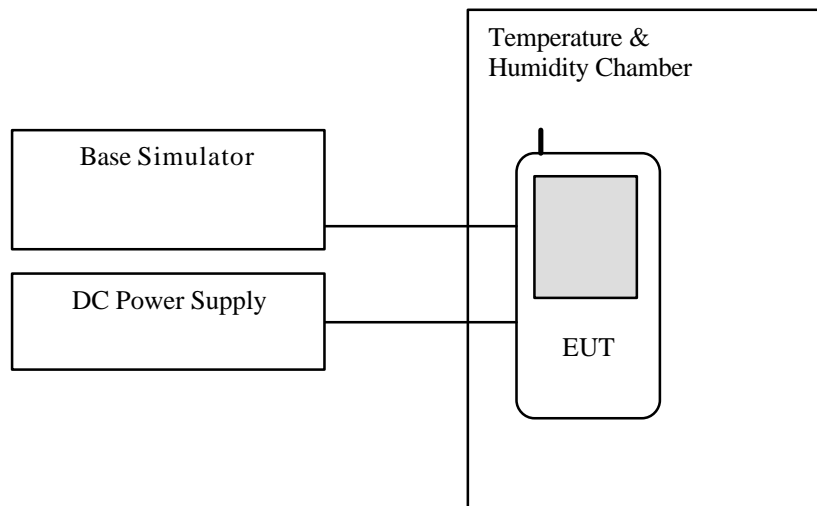

4.5.3 Test Data:

‡ CDMA800 Temperature Variations

Test conditions	CDMA800 CH380 (836.4MHz)		
	Deviation (Hz)	limits (Hz)	Pass/fail
50 °C	-31	±836	Pass
40 °C	-42		
30 °C	34		
20 °C	38		
10 °C	-45		
0 °C	37		
-10 °C	-33		
-20 °C	24		
-30 °C	32		

‡ CDMA800 Voltage Variations

Test conditions	CDMA800 CH380 (836.4MHz)		
	Deviation (Hz)	limits (Hz)	Pass/fail
3.145 V	55	±836	Pass
3.7 V	77		
4.225 V	62		

‡ CDMA1900 Temperature Variations

Test conditions	CDMA1900 CH600 (1880MHz)		
	Deviation	limits	Pass/fail
	(Hz)	(Hz)	
50 °C	60	±880	Pass
40 °C	67		
30 °C	61		
20 °C	54		
10 °C	64		
0 °C	61		
-10 °C	48		
-20 °C	72		
-30 °C	54		

‡ CDMA1900 Voltage Variations

Test conditions	CDMA1900 CH600 (1880MHz)		
	Deviation	limits	Pass/fail
	(Hz)	(Hz)	
3.145 V	44	±880	Pass
19.0 V	31		
4.225 V	48		

5. Test Equipment

Location	Equipment Name	Brand	Model	S/N	Last Cal. Date	Next Cal. Date
Radiation	BILOG Antenna 08	Schaffner	CBL6112B	2756	06/07/2006	06/07/2007
Radiation	Coaxial Cable Chmb 02-10M	Belden	RG-8/U	Chmb 02-10M	12/28/2005	12/28/2006
Radiation	Digital Hygro-Thermometer Chmb 02	MicroLife	HT-2126G	Chmb 02	11/30/2004	12/30/2006
Radiation	EMI Receiver 03	HP	85460A	3448A00209	04/01/2006	04/01/2007
Radiation	Spectrum Analyzer 13	Advantest	R3132	121200411	02/17/2006	02/17/2007
Radiation	Horn Antenna 02	Com-Power	AH-118	10088	07/22/2006	07/22/2007
Radiation	Horn Antenna 04	Com-Power	AH-826	081-001	01/13/2006	01/13/2007
Radiation	Horn Antenna 05	Com-Power	AH-640	100A	09/30/2006	09/30/2007
Radiation	Microwave Cable RF SK-01	HUBER+SUHNERAG.	Sucoflex 102	22139 /2	07/07/2006	07/07/2007
Chamber 05	Peak Power Analyzer	HP	8990A	3621A01269	03/28/2006	03/28/2007
Chamber 05	Power Sensor Radar	HP	84815A	3318A01828	03/28/2006	03/28/2007
Radiation	Preamplifier 02	MITEQ	AFS44-00102 650-40-10P-4 4	728229	11/28/2006	11/28/2007
Radiation	Preamplifier 10	MITEQ	JS-26004000- 27-5A	818471	11/22/2006	11/22/2007
Radiation	Band Reject Filter	Wainwright	WRCG 824/ 849-60/10SS	003	N/A	N/A
Radiation	Band Reject Filter	Wainwright	WRCG 1850/ 1910-60/10SS	007	N/A	N/A
Radiation	High Pass Filter 01	HEWLETT-PACKARD	84300-80038	001	N/A	N/A
Radiation	High Pass Filter 02	HEWLETT-PACKARD	84300-80039	005	N/A	N/A
Radiation	Spectrum Analyzer 14	Advantest	R3182	140600028	11/22/2006	11/22/2007

Note: Calibration is traceable to NIST or national or international standards.

6. Appendix

6.1 Appendix A: Photographs of EUT Configuration Test Set Up

Please refer to the attached file.

6.2 Appendix B: Photographs of EUT

Please refer to the attached file.