



## Electromagnetic Compatibility Test Report

**Tests Performed on an RF Ideas**

**Card Reader, Model pcProx-USB**

**Radiometrics Document RP-4749**



*Product Detail:*

**FCC ID: M9MPCPROXHUSB100**

Equipment type: Low power 125 kHz Transmitter

*Test Standards:*

US CFR Title 47, Chapter I, FCC Part 15 Subpart C

FCC Part 15 CFR Title 47: 2001

Industry Canada RSS-210, Issue 5 as required for Category I Equipment

This report concerns: Original Grant for Certification

FCC Part 15 Subpart C

*Tests Performed For:*

**RF Ideas**

4238 B Arlington Heights Rd., #244

Arlington Heights, IL 60004

Phone: (847) 870-1723

*Test Facility:*

**Radiometrics Midwest Corporation**

12 East Devonwood

Romeoville, IL 60446

Phone: (815) 293-0772

e-mail: info@radiomet.com

*Test Date(s): (Month-Day-Year)*

February 28 and March 14, 2002

**Document RP-4749 Revisions:**

Rev.	Issue Date	Affected Pages	Revised By	Authorized Signature for Revision
0	May 1, 2002			

<b>RADIOMETRICS MIDWEST CORPORATION - EMC Test Report</b>		
<i>Equipment Tested (Company, Model, Product Name):</i> RF Ideas, pcProx-USB, card reader	<i>Document No.:</i> RP-4749 Rev. 0	<i>Page:</i> 2 of 12

## Table of Contents

<a href="#">1 ADMINISTRATIVE DATA</a> .....	3
<a href="#">2 TEST SUMMARY AND RESULTS</a> .....	3
<a href="#">3 EQUIPMENT UNDER TEST (EUT) DETAILS</a> .....	4
<a href="#">3.1 EUT Description</a> .....	4
<a href="#">3.2 Related Submittals</a> .....	4
<a href="#">4 TESTED SYSTEM DETAILS</a> .....	4
<a href="#">4.1 Tested System Configuration</a> .....	4
<a href="#">4.2 Special Accessories</a> .....	4
<a href="#">4.3 Equipment Modifications</a> .....	5
<a href="#">5 TEST SPECIFICATIONS AND RELATED DOCUMENTS</a> .....	5
<a href="#">6 RADIOMETRICS' TEST FACILITIES</a> .....	5
<a href="#">7 DEVIATIONS AND EXCLUSIONS FROM THE TEST SPECIFICATIONS</a> .....	6
<a href="#">8 TEST PROCEDURES</a> .....	6
<a href="#">8.1 Radiated RF Emissions Measurement Procedures</a> .....	6
<a href="#">8.1.1 Field Strength Calculation</a> .....	7
<a href="#">8.1.2 Conducted Emission Measurement Procedures</a> .....	7
<a href="#">9 CERTIFICATION</a> .....	8
<a href="#">10 TEST EQUIPMENT TABLE</a> .....	8
<a href="#">11 TEST SETUP DOCUMENTATION</a> .....	9
<a href="#">Figure 1. Configuration of Tested System</a> .....	9
<a href="#">12 DETAILED TEST RESULTS</a> .....	10
<a href="#">12.1 Radiated Emissions Test Results</a> .....	10
<a href="#">12.2 Magnetic Field Radiated Emissions Results (0.009 to 30 MHz)</a> .....	12
<a href="#">12.3 Conducted Emission Test Results</a> .....	12

Notice: This report must not be reproduced (except in full) without the written approval of Radiometrics Midwest Corporation.

**RADIOMETRICS MIDWEST CORPORATION - EMC Test Report**

<i>Equipment Tested (Company, Model, Product Name):</i> RF Ideas, pcProx-USB, card reader	<i>Document No.:</i> RP-4749 Rev. 0	<i>Page:</i> 3 of 12
--	--	-------------------------

**1 ADMINISTRATIVE DATA**

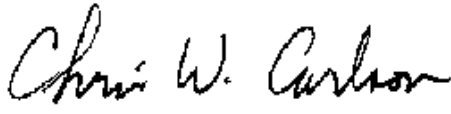
<i>Equipment Under Test:</i> An RF Ideas, card reader Model: pcProx-USB Serial Number: none This will be referred to as the EUT in this Report	
<i>Date EUT Received at Radiometrics: (Month-Day-Year)</i> February 28, 2002	<i>Test Date(s): (Month-Day-Year)</i> February 28 and March 14, 2002
<i>Test Report Written By:</i> Joseph Strzelecki Radiometrics Midwest Corp.	<i>Test Witnessed By:</i> The tests were not witnessed by RF Ideas
<i>Radiometrics' Personnel Responsible for Test:</i>  Joseph Strzelecki Senior EMC Engineer NARTE EMC-000877-NE	<i>Test Report Approved By</i>  Chris W. Carlson Director of Engineering NARTE EMC-000921-NE

**2 TEST SUMMARY AND RESULTS**

The EUT (Equipment Under Test) is a card reader, Model pcProx-USB, manufactured by RF Ideas. The detailed test results are presented in a separate section. The following is a summary of the test results.

**Emissions Tests Results**

Environmental Phenomena	Frequency Range	Basic Standard	Test Result
RF Radiated Emissions	30-1000 MHz	RSS-210 & FCC Part 15	Pass
Conducted Emissions, AC Mains	0.45 - 30 MHz	RSS-210 & FCC Part 15	Pass
Occupied Bandwidth Test	Fundamental Freq.	RSS-210 & FCC Part 15	Pass
RF Radiated Emissions H-Field	0.009 – 30 MHz	RSS-210 & FCC Part 15	Pass

RADIOMETRICS MIDWEST CORPORATION - EMC Test Report		
<i>Equipment Tested (Company, Model, Product Name):</i>	<i>Document No.:</i>	<i>Page:</i>
RF Ideas, pcProx-USB, card reader	RP-4749 Rev. 0	4 of 12

### 3 EQUIPMENT UNDER TEST (EUT) DETAILS

#### 3.1 EUT Description

The EUT is a card reader, Model pcProx-USB, manufactured by RF Ideas. The EUT was in good working condition during the tests, with no known defects.

#### 3.2 Related Submittals

RF Ideas is not submitting any other products simultaneously for equipment authorization related to the EUT.

### 4 TESTED SYSTEM DETAILS

#### 4.1 Tested System Configuration

The system was configured for testing in a typical fashion. The EUT was placed on an 80-cm high, nonconductive test stand. The testing was performed in conditions as close as possible to installed conditions. Wiring was consistent with manufacturer's recommendations. A one meter, unterminated long field wire was connected to the EUT during the tests. Since the EUT is wall mounted, it was placed in an upright configuration during the tests.

**Tested System Configuration List**

Item	Description	Type*	Manufacturer	Model Number	Serial Number
1	card reader	E	RF Ideas	pcProx-USB	none
2	VAIO Notebook PC	H	Sony, Inc.	PCG-9251	28310531 4024706
3	VAIO Power supply	H	Sony, Inc.	N50	0954552P
4	Printer	P	Star	NX-1001	510010542390

\* Type: E = EUT, P = Peripheral, S = Support Equipment; H = Host System

**List of System Cables**

QTY	Length (m)	Cable Description	Connected to (Item #)	Shielded?
1	1.85	USB Serial	#1 and #2	Yes
1	0.8	AC Cord to Computer power supply	#3	No
1	1.8	Low voltage power cord to Notebook	#2 and #3	No
1	1.8	Printer Cable	#2 and #4	Yes

The wiring was consistent with manufacturer's recommendations. The system was configured for testing in a typical fashion (as a customer would normally use it). Power was supplied to the host computer at 115 VAC, 60 Hz single-phase. The EUT was powered from the host computer.

#### 4.2 Special Accessories

No special accessories were used during the tests in order to achieve compliance.

RADIOMETRICS MIDWEST CORPORATION - EMC Test Report		
<i>Equipment Tested (Company, Model, Product Name):</i> RF Ideas, pcProx-USB, card reader	<i>Document No.:</i> RP-4749 Rev. 0	<i>Page:</i> 5 of 12

### 4.3 Equipment Modifications

The following modification was made to the EUT at Radiometrics' test facility in order to comply with the standards listed in this report: A 820 pF capacitor was added to C3 and C4. The pads were already in place on the PCB.

## 5 TEST SPECIFICATIONS AND RELATED DOCUMENTS

### Test Specifications

Document	Date	Title
FCC CFR Title 47	1999	Code of Federal Regulations Title 47, Chapter 1, Federal Communications Commission, Part 15 - Radio Frequency Devices
ANSI C63.4-1992	1992	Methods of Measurement of Radio Noise Emissions from Low-Voltage Electrical and Electronic Equipment in the Range of 9 kHz to 40 GHz
IC RSS-210 Issue 5	2001	Low Power Licence-Exempt Radiocommunication Devices (All Frequency Bands)
IC RSS-212 Issue 1	1998	Test Methods For Radio Equipment

The test procedures used are in accordance with the ANSI document C63.4-1992, (July 17, 1992) "Methods of Measurement of Radio Noise Emissions from Low-Voltage Electrical and Electronic Equipment in the Range of 9 kHz to 40 GHz". The specific procedures are described herein. Radiated testing was performed at an antenna to EUT distance of 3 meters. The antenna was raised and lowered from 1 to 4 meters.

## 6 RADIOMETRICS' TEST FACILITIES

The results of these tests were obtained at Radiometrics Midwest Corp. in Romeoville, Illinois, USA. Radiometrics has been accredited by A2LA (American Association for Laboratory Accreditation) to conform to ISO/IEC 17025: 1999 "General Requirements for the Competence of Calibration and Testing Laboratories". Radiometrics' Lab Code is 121191 and Certification Number is 1495.01. Radiometrics' scope of accreditation includes all of the "basic standards" listed herein. A copy of the accreditation can be accessed on our web site ([www.radiomet.com](http://www.radiomet.com)). Radiometrics accreditation status can be verified at A2LA's web site ([www.a2la.org](http://www.a2la.org)).

The following is a list of shielded enclosures located in Romeoville, Illinois:

Chamber A: Is an anechoic chamber that measures 24' L X 12' W X 12' H. The walls and ceiling are fully lined with ferrite absorber tiles. The floor has a 10' x 10' section of ferrite absorber tiles in the located in the center. Panashield of Rowayton, Connecticut manufactured the chamber. The enclosure is NAMAS certified.

Chamber B: Is a shielded enclosure that measures 24' L X 12' W X 8' H. Erik A. Lindgren & Associates of Chicago, Illinois manufactured the enclosure.

Chamber C: Is a shielded enclosure that measures 20' L X 10' W X 8' H. Lindgren RF Enclosures Inc. of Addison, Illinois manufactured the enclosure.

RADIOMETRICS MIDWEST CORPORATION - EMC Test Report		
<i>Equipment Tested (Company, Model, Product Name):</i>	<i>Document No.:</i>	<i>Page:</i>
RF Ideas, pcProx-USB, card reader	RP-4749 Rev. 0	6 of 12

Chamber D: Is a fully anechoic chamber that measures 22' L X 10' W X 10' H. The walls, ceiling and floor are fully lined with ferrite absorber tiles. Braden Shielding Systems of Tulsa, Oklahoma manufactured the chamber.

A separate ten-foot long, brass plated, steel ground rod attached via a 6 inch copper braid grounds each of the above chambers. Each enclosure is also equipped with low-pass power line filters.

Open Area Test Site (OATS): Is located on 8625 Helmar Road in Newark, Illinois, USA and measures 56' L X 24' W X 17' H. The entire open field test site has a metal ground screen. The FCC has accepted these sites as test site number 31040/SIT 1300F2. The FCC test site Registration Number is 90897. Details of the site characteristics are on file with the Industry Canada as file number IC3124.

A complete list of the test equipment is provided herein. The calibration due dates are indicated on the equipment list. The equipment is calibrated in accordance to ANSI/NCSL Z540-1 with traceability to the National Institute of Standards and Technology (NIST).

## 7 DEVIATIONS AND EXCLUSIONS FROM THE TEST SPECIFICATIONS

There were no deviations or exclusions from the test specifications.

## 8 TEST PROCEDURES

The test procedures used are in accordance with the Industry Canada RSS-212 and ANSI document C63.4-1992, (July 17, 1992) "Methods of Measurement of Radio Noise Emissions from Low-Voltage Electrical and Electronic Equipment in the Range of 9 kHz to 40 GHz". The specific procedures are described herein. Radiated testing was performed at an antenna to EUT distance of 3 meters. The antenna was raised and lowered from 1 to 4 meters.

### 8.1 Radiated RF Emissions Measurement Procedures

Radiated emission measurements were performed with linearly polarized broadband antennas. The results obtained with these antennas can be correlated with results obtained with a tuned dipole antenna. Below 1 GHz, when a radiated emission is detected approaching the specification limit, the measurement of the emission is repeated using a tuned dipole antenna with a Roberts Balun.

The radiated emission measurements were performed with a spectrum analyzer. The bandwidth used from 450 kHz to 30 MHz is 9 or 10 kHz and the bandwidth from 30 MHz to 1000 MHz is 100 or 120 kHz. Above 1 GHz, a 1 MHz bandwidth is used. A 10 dB linearity check is performed prior to start of testing in order to determine if an overload condition exists.

From 30 to 1000 MHz an Anritsu Spectrum analyzer and a MITEQ AM-1431 amplifier with a 10 dB attenuator connected to the input. The out of band emissions and the ambient emissions were below the level of input overload (80 dBuV).

Preliminary radiated emission tests were performed inside of an anechoic enclosure. The frequency range from 30 to 1000 MHz was scanned and plotted using the peak detector function. The test antennas were positioned 3 meters from the EUT. The results of the preliminary scans were only used to identify the frequencies being emitted from the EUT and were not used to determine compliance with the test specification. Radiated emission measurements are performed with linearly polarized broadband antennas.

RADIOMETRICS MIDWEST CORPORATION - EMC Test Report		
<i>Equipment Tested (Company, Model, Product Name):</i>	<i>Document No.:</i>	<i>Page:</i>
RF Ideas, pcProx-USB, card reader	RP-4749 Rev. 0	7 of 12

Final radiated emissions measurements were performed in the open area test site at a test distance of 3 meters. Measurements were performed using the peak or quasi-peak detector function. The detected emission levels were maximized by rotating the EUT, adjusting the positions of all cables, and by scanning the measurement antenna from 1 to 4 meters above the ground. The open area test site used to collect the radiated data is located on 8625 Helmar Road in Newark, Illinois. The open field test site has a metal ground screen. All other tests are performed at 12 East Devonwood Ave. Romeoville, Illinois EMI test lab.

The entire frequency range from 30 to 2000 MHz was slowly scanned with particular attention paid to those frequency ranges which appeared high in the preliminary emission scan. Measurements were performed using two antenna polarizations, (vertical and horizontal). The worst case emissions were recorded.

### 8.1.1 Field Strength Calculation

The field strength is calculated by adding the Antenna Factor and Cable Loss, and by subtracting the Amplifier Gain from the measured reading. The basic equation with a sample calculation is as follows:

$$FS = RA + AF + CF - AG$$

Where: FS = Field Strength

RA = Receiver Amplitude

AF = Antenna Factor

CF = Cable Attenuation Factor

AG = Amplifier Gain

Assume a receiver reading of 49.5 dBuV is obtained. The Antenna Factor of 8.1 and a Cable Factor of 1.7 is added. The Amplifier Gain of 23.3 dB is subtracted, giving a field strength of 36 dBuV/m. The 36 dBuV/m can be mathematically converted to its corresponding level in uV/m.

$$FS = 49.5 + 8.1 + 1.7 - 23.3 = 36.0 \text{ dBuV/m}$$

$$\text{Level in uV/m} = \text{Common Antilogarithm} [(36 \text{ dBuV/m})/20] = 63.1 \text{ uV/m}$$

### 8.1.2 Conducted Emission Measurement Procedures

A computer-controlled analyzer was used to perform the conducted emissions measurements. The frequency range was divided into 500 subranges equally spaced on a logarithmic scale. The computer recorded the peak of each subrange. This data was then plotted on semi-log graph paper generated by the computer and plotter. Adjusting the positions of the cables and orientation of the test system then maximizes the highest emissions.

Mains Conducted emission measurements were performed using a 50 Ohm/50 uH Line Impedance Stabilization Network (LISN) as the pick-up device. Measurements were repeated on both leads within the power cord. If the EUT power cord exceeded 80 cm in length, the excess length of the power cord was made into a 30 to 40 cm bundle near the center of the cord. The LISN was placed on the floor at the base of the test platform and electrically bonded to the ground plane.

Broadband conducted emissions may exceed the following limits by no more than 13 dB. An emission is defined as broadband if the average detector amplitude is 6 dB or more under the quasi-peak detector amplitude.

**RADIOMETRICS MIDWEST CORPORATION - EMC Test Report**

<i>Equipment Tested (Company, Model, Product Name):</i> RF Ideas, pcProx-USB, card reader	<i>Document No.:</i> RP-4749 Rev. 0	<i>Page:</i> 8 of 12
--	--	-------------------------

**FCC Limits of Conducted Emissions at the AC Mains Ports**

Frequency Range (MHz)	Class A, QP Limits (dBuV)	Class B, QP Limit (dBuV)
0.450 - 1.705	60.0	48.0
1.705 - 30	69.5	48.0

**9 CERTIFICATION**

Radiometrics Midwest Corporation certifies that the data contained herein was taken under conditions that meet or exceed the requirements of the test specification. The results relate only to the EUT listed herein. Any modifications made to the EUT subsequent to the indicated test date will invalidate the data and void this certification.

**10 TEST EQUIPMENT TABLE**

RMC ID	Manufacturer	Description	Model No.	Serial No.	Frequency Range	Cal Period	Cal Date
AMP-12	MITEQ	Pre-amplifier	AM-1431	530935	0.01-1000MHz	12 Mo.	12/28/01
AMP-22	Anritsu	Pre-amplifier	MH648A	M23969	0.1-1200MHz	12 Mo.	11/26/01
ANT-03	Tensor	Biconical Antenna	4104	2231	20-200MHz	24 Mo.	08/07/01
ANT-06	EMCO	Log-Periodic Ant.	3146	1248	200-1000MHz	24 mo	08/07/01
ANT-11	RMC	Dipole Antennas	HW1010	201	25-1000MHz	12 Mo.	07/10/01
ANT-25	ARA	Super Log Antenna	LPB-2520/A	1116	20-2000MHz	24 Mo.	8/30/01
ANT-28	Empire	Loop Antenna	LG-105	102	10-150kHz	24 Mo.	10/24/00
ANT-29	Empire	Loop Antenna	LP-105	656	0.15-30MHz	24 Mo.	10/24/00
HPF-01	Solar	High Pass Filter	7930-100	HPF-1	0.15-30MHz	24 Mo.	12/28/00
LSN-01	Electrometrics	LISN	FCC/VDE 50/2	1001	0.01-30MHz	24 Mo.	01/04/01
LSN-02	Electrometrics	LISN	LISN 25/3	1063	0.01-30MHz	24 Mo.	03/30/01
LSN-03	Farnell	LISN	1EXLSN30B	000314	0.01-30MHz	24 Mo.	01/04/01
REC-03	Anritsu	Spectrum Analyzer	MS2601B	MT94589	0.01-2200MHz	12 Mo.	10/12/01
THM-01	Extech Inst.	Temp/Humid Meter	4465CF	001106557	N/A	12 Mo.	12/26/01

Note: All calibrated equipment is subject to periodic checks.

NCR – No Calibration Required. Device monitored by calibrated equipment. N/A: Not Applicable.



**11 TEST SETUP DOCUMENTATION**

**Figure 1. Configuration of Tested System**

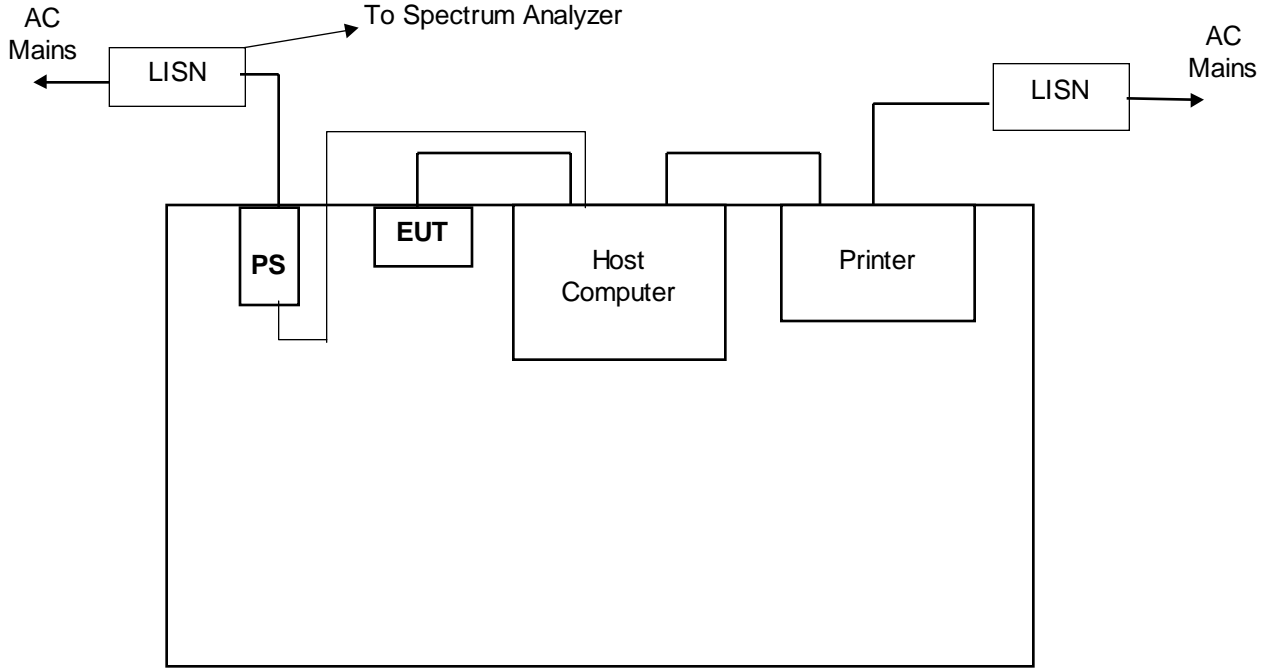

1x1.5m surface 80 cm above  
Flush-mount Turntable

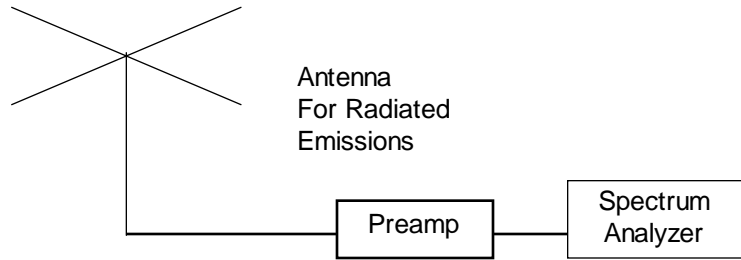

**Radiated Emissions:**

- LISN's not used
- AC outlet with low-pass filter at the base of the turntable
- No vertical conductive wall
- Antenna height varied from 1 to 4 meters
- Distance from antenna to tested system is 3 meters

**Notes:**

- Not to Scale

**Conducted Emissions:**

- LISN's at least 80 cm from EUT chassis
- Vertical conductive plane 40 cm from rear of table top
- EUT power cord bundled
- Test platform is not rotated

**RADIOMETRICS MIDWEST CORPORATION - EMC Test Report**

<i>Equipment Tested (Company, Model, Product Name):</i> RF Ideas, pcProx-USB, card reader	<i>Document No.:</i> RP-4749 Rev. 0	<i>Page:</i> 10 of 12
--	--	--------------------------

**12 DETAILED TEST RESULTS**

**12.1 Radiated Emissions Test Results**

Manufacturer	RF Ideas	Specification	FCC Part 15 Subpart C & RSS-210
Model	pcProx-USB	Test Date	3/14/2002
Serial Number	None	Test Distance	3 Meters
Abbreviations	Pol = Antenna Polarization; V = Vertical; H = Horizontal; BC = Biconical (ANT-3); LP = Log-Periodic (ANT-6); HN = Horn (ANT-13) P = peak; Q = QP		

Freq. MHz	Meter Reading dBuV	Antenna		Corr. Factors dB	Field Strength dBuV/m		Margin Under Limit dB
		Factor dB	Pol/ Type		EUT	Limit	
48.7	43.4 P	11.8	H/BC	-25.9	29.3	40.0	10.7
61.3	46.3 P	8.9	H/BC	-25.7	29.5	40.0	10.5
64.3	46.8 P	7.9	H/BC	-25.6	29.0	40.0	11.0
65.6	47.0 P	7.4	H/BC	-25.6	28.8	40.0	11.2
120.2	42.9 P	12.2	H/BC	-24.7	30.4	43.5	13.1
140.2	41.7 P	12.0	H/BC	-24.4	29.2	43.5	14.3
165.2	39.2 P	15.1	H/BC	-24.1	30.3	43.5	13.2
195.4	42.6 P	16.9	H/BC	-23.6	35.9	43.5	7.6
198.0	47.3 Q	16.7	H/BC	-23.6	40.4	43.5	3.1
206.0	44.9 Q	16.2	H/BC	-23.4	37.7	43.5	5.8
208.3	46.1 Q	16.0	H/BC	-23.4	38.7	43.5	4.8
217.6	44.6 P	15.6	H/BC	-23.2	37.0	46.0	9.0
227.3	43.8 P	15.8	H/BC	-23.1	36.5	46.0	9.5
237.1	43.1 P	16.5	H/BC	-22.9	36.8	46.0	9.2
238.9	45.2 Q	16.6	H/BC	-22.9	38.9	46.0	7.1
247.2	42.4 P	17.7	H/BC	-22.7	37.5	46.0	8.5
251.1	48.6 P	12.7	H/LP	-22.6	38.7	46.0	7.3
253.1	47.9 P	12.8	H/LP	-22.5	38.2	46.0	7.8
263.4	48.0 P	13.1	H/LP	-22.4	38.8	46.0	7.2
264.4	49.2 P	13.2	H/LP	-22.4	40.0	46.0	6.0
266.2	48.8 P	13.2	H/LP	-22.3	39.7	46.0	6.3
271.8	47.7 P	13.5	H/LP	-22.2	39.0	46.0	7.0
279.3	45.9 P	13.9	H/LP	-22.0	37.8	46.0	8.2
281.0	48.8 P	13.9	H/LP	-22.0	40.7	46.0	5.3
289.8	41.5 P	14.3	H/LP	-21.8	34.0	46.0	12.0
299.7	46.5 P	15.0	H/LP	-21.5	40.0	46.0	6.0
321.3	45.5 P	15.1	H/LP	-20.9	39.7	46.0	6.3

**RADIOMETRICS MIDWEST CORPORATION - EMC Test Report**

*Equipment Tested (Company, Model, Product Name):*

RF Ideas, pcProx-USB, card reader

*Document No.:*

RP-4749 Rev. 0

*Page:*

11 of 12

Freq. MHz	Meter Reading dBuV	Antenna		Corr. Factors dB	Field Strength dBuV/m		Margin Under Limit dB
		Factor dB	Pol/ Type		EUT	Limit	
40.0	44.8 P	10.7	V/BC	-26.1	29.4	40.0	10.6
48.7	48.8 Q	11.1	V/BC	-25.9	34.0	40.0	6.0
60.0	49.8 P	9.1	V/BC	-25.7	33.2	40.0	6.8
65.7	47.9 P	7.0	V/BC	-25.6	29.3	40.0	10.7
70.1	49.8 P	6.3	V/BC	-25.5	30.6	40.0	9.4
74.7	45.5 P	6.1	V/BC	-25.5	26.2	40.0	13.8
84.6	45.9 P	8.8	V/BC	-25.3	29.5	40.0	10.5
99.4	45.3 P	11.5	V/BC	-25.0	31.8	43.5	11.7
116.5	43.3 P	13.2	V/BC	-24.8	31.7	43.5	11.8
120.7	48.8 P	12.9	V/BC	-24.7	37.0	43.5	6.5
140.9	45.7 P	12.4	V/BC	-24.4	33.7	43.5	9.8
142.7	46.4 P	12.5	V/BC	-24.4	34.5	43.5	9.0
147.2	44.2 P	13.0	V/BC	-24.3	32.8	43.5	10.7
149.9	44.9 P	13.5	V/BC	-24.3	34.1	43.5	9.4
150.9	44.5 P	13.6	V/BC	-24.3	33.8	43.5	9.7
197.8	47.4 P	16.6	V/BC	-23.6	40.4	43.5	3.1
208.4	43.1 P	16.3	V/BC	-23.4	36.0	43.5	7.5
224.0	43.2 P	16.2	V/BC	-23.1	36.3	46.0	9.7
236.9	43.7 P	17.2	V/BC	-22.9	38.0	46.0	8.0
239.2	44.7 P	17.9	V/BC	-22.8	39.8	46.0	6.2
279.9	42.6 P	13.9	V/LP	-22.0	34.5	46.0	11.5
318.8	42.8 P	15.2	V/LP	-21.0	37.0	46.0	9.0
360.9	41.3 P	15.4	V/LP	-20.0	36.7	46.0	9.3
376.4	40.8 P	15.6	V/LP	-19.9	36.5	46.0	9.5
395.8	40.2 P	16.2	V/LP	-20.1	36.3	46.0	9.7
420.3	35.8 P	16.1	V/LP	-20.3	31.6	46.0	14.4

Judgment: Passed by 3.1 dB.

The emissions within 8 dB of the limits were from the host computer, not the EUT.

No Emissions were detected from 400 to 2000 MHz within 10 dB of the limits.

RADIOMETRICS MIDWEST CORPORATION - EMC Test Report		
<i>Equipment Tested (Company, Model, Product Name):</i>	<i>Document No.:</i>	<i>Page:</i>
RF Ideas, pcProx-USB, card reader	RP-4749 Rev. 0	12 of 12

## 12.2 Magnetic Field Radiated Emissions Results (0.009 to 30 MHz)

Manufacturer	RF Ideas	Specification	FCC 15 & RSS-210
Model	pcProx-USB	Test Date	3/14/2002
Serial Number	none	Test Distance	3 Meters
Notes	Corr. Factors = cable loss - preamp gain - distance factor. Decay Exponent = 2 Shielded Loop Antennas were used for this test. Amplifier gain is 36 dB		
Abbreviations	P = peak; Q = QP		

Freq. kHz	Meter Reading dBuV	Antenna Factor dB	Corr. Factors dB	Field Strength dBuV/m		Margin Under Limit dB
				EUT	Limit	
125	58.9	50.1	-116.0	-7.0	25.7	32.7

No emissions were detected from 125 kHz to 30 MHz with 15 dB of the Limit  
 Judgement: Passed by at least 15.0 dB.

## 12.3 Conducted Emission Test Results

The initial step in collecting conducted data is a peak detector scan and the plotting of the measurement range. Significant peaks are then marked as shown on the following table, and these signals are then measured with the quasi-peak detector. The following represents the worst case emissions from the host computer (with the EUT connected) power cord, after testing all modes of operation.

Test Date : March 11, 2002  
 Corr. Factors = cable loss + LISN Loss

Line Tested	Freq. MHz	Meter Reading dBuV	Correction Factors dB	Strength of Signal dBuV		Margin Under Limit dB
				EUT	Limit	
AC Hot	0.48	36.2	0.2	36.4	48.0	11.6
AC Hot	0.54	38.1	0.2	38.3	48.0	9.7
AC Hot	5.8	30.6	0.3	30.9	48.0	17.1
AC Neutral	0.48	37.8	0.2	38.0	48.0	10
AC Neutral	0.54	40.1	0.2	40.3	48.0	7.7
AC Neutral	6.1	31.6	0.3	31.9	48.0	16.1

No other emissions were detected within 15 dB of the Limit

\* All reading are quasi-peak with a 9 kHz bandwidth and no video filter.

Judgment: Passed by 7.7 dB