



ZENOWAY

ZenoCCU

User manual

Version: 0.2

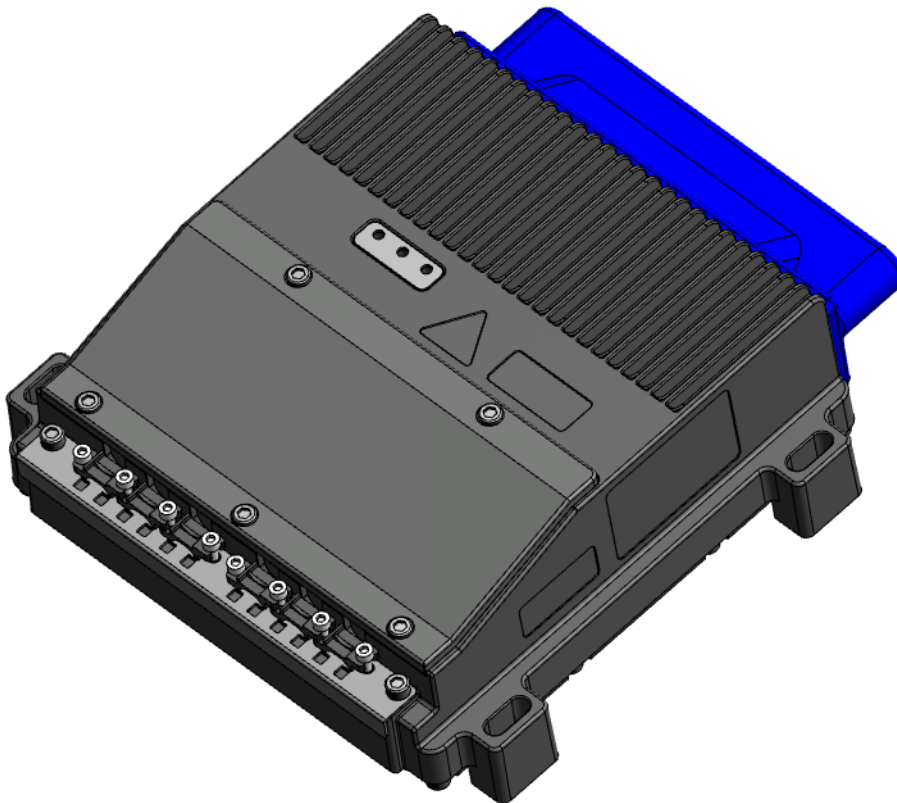

Contents

1	Introduction	4
1.1	Design elements in this manual	4
1.2	Additional documents	4
2	Product description / functional description	5
2.1	Intended use	5
2.2	Mount, operate and service the device correctly	6
2.3	Required qualification	6
2.4	Scope of delivery	6
2.5	Construction	7
2.6	Status of LEDs	7
2.7	Designation and labeling	8
3	Preparing the product	10
3.1	Unpacking the device	10
3.2	Transport	10
3.3	Storage	10
4	Technical data	10
4.1	General	10
4.2	Device dimensions	12
4.3	Interfaces	12
4.4	Antennae	14
5	Mechanical mounting	14
5.1	Safety notice	15
6	Connecting the cables and cable cover	17
6.1	Preparing the cables, cable grommets and dummy grommets	17
6.2	Plugging in the power supply cable	17
6.3	Securing the ground using ring tongue to the ground bolt	17
6.4	Securing the power supply cable to the strain relief rail	17
6.5	Connecting further cables	18
6.6	Closing off unused cable openings	18
6.7	Fitting the cable cover	18
7	Electrical installation	18
7.1	Safety notice	18
7.2	Connection to the power supply	19
7.2.1	Electrical connection to vehicles	19
7.2.2	Observe the potential ratios	20
7.2.3	Electrically isolated installation	20
7.3	Securing the ground using ring tongue to the ground bolt	20

8	Operation / usage	20
8.1	Starting and shutting down	21
8.2	Status display	21
8.3	Access	21
8.4	Settings	21
8.5	Accessories	22
8.6	Antennae	22
9	Servicing and maintenance	22
9.1	Cleaning	22
9.2	Inspection and repair	23
10	End-of-life device disposal	23
11	Technical customer support	23
12	??Form for device returns??	24

1 Introduction

1.1 Design elements in this manual

Notes on hazards to persons are shown as follows.

 DANGER / WARNING / CAUTION Personal injury	
DANGER	a danger that will lead to immediate death or severe injury.
WARNING	a danger that can lead to death or severe injury.
CAUTION	a hazard that can lead to slight injuries.

Notes on physical damage are shown as follows.

NOTICE: Physical damage
Note on potential physical damage

Notes using the product and further information are shown as follows.

"ICON" TIP
Tips for using the product

1.2 Additional documents

Description	Purpose	Target group	Availability
Data sheet	ZW_Datenblatt_Zeno CAM_V1.4.pdf	Skilled personnel	
Safety notice	Protection of personnel and physical damage	Skilled personnel	
Quick start manual	Commissioning	Skilled personnel	
Manual	Complete operating instructions	Skilled personnel and trained users	
Maintenance manual	Maintenance instructions	Skilled personnel	
Pilot Pro application operating	Application reference	Skilled personnel	

instructions		
Pilot Pro Web UI operating instructions	Configuration interface	Skilled personnel

Retain all enclosed manuals and instructions for subsequent use.

Latest manual version on the internet

The latest versions of the manuals can be found at

www.abc.xy

Observe safety notices

Observe the safety notices included with the device.

2 Product description / functional description

2.1 Intended use

The ZenoCCU is a computing unit and is designed for use in the industrial environment. Any other or additional use beyond this is deemed improper. The operating company of the ZenoCCU shall be responsible for any resulting damage.

This also applies to unauthorized modifications made to the device.

The ZenoCCU can be operated with the original power supply cable or a DC voltage source with 9 to 60 VDC and 70W approved by Zeno Track. The maximum operating temperature of the device is +45 °C. Contact Zeno Track for further information and support. Intended use includes compliance with all safety information, the permitted environmental conditions and any specifications for the device.

The ZenoCCU:

- ▶ is not approved for use in the EX zone (risk of explosion), on ships and on rail vehicles.
- ▶ is not approved for use in life-support systems or safety-critical systems or applications where a system malfunction can lead to the direct or indirect endangerment of human life.
- ▶ This equipment is not suitable for use in locations where children are likely to be present.

It is only permitted to use accessories that are listed in the operating manual or approved by Zeno Track for operation with the ZenoCCU. Otherwise, any Zeno Track GmbH warranty for this device will be void.

Requirements for safe operation

The requirements are:

- ▶ Proper transport and storage
- ▶ Proper mounting and application
- ▶ Proper maintenance and servicing
- ▶ Operation by trained personnel

Observe the permitted environmental conditions

The ZenoCCU is only permitted to be used under the specified environmental conditions (see chapter XXX).

2.2 Mount, operate and service the device correctly

The ZenoCCU has been designed and built according to the latest technical safety regulations. However, the operation of the device can endanger personnel or third parties and cause damage to the device and other material assets when, for example, the device is

- ▶ installed incorrectly or configured improperly.
- ▶ operated by untrained or uninstructed personnel
- ▶ improperly operated and maintained.
- ▶ not used as intended.

The owner/operator commitments with regards to safety (accident prevention regulations, occupational safety)

must be observed

2.3 Required qualification

Only skilled personnel are permitted to put into operation (electrical connection and mechanical mounting) and maintain the ZenoCCU.

Skilled personnel for the purpose of these safety notices are persons who are familiar with these procedures and have the corresponding qualifications for their activities, such as:

- ▶ Training or instruction in how to switch on and off, ground, and label power circuits and devices or systems in accordance with the current standards for safety equipment, as well as the required authorization.
- ▶ Training or instruction in how to maintain and use appropriate safety equipment in accordance with the current standards for safety equipment.
- ▶ Training in first aid.

Users of the ZenoCCU must be trained by skilled personnel and instructed about the operation of the device

2.4 Scope of delivery

Scope of delivery

- ▶ ZenoCCU
- ▶ Cable duct cover
- ▶ Strain relief
- ▶ Cable bushings and dummy plugs

Optional additional parts

- ▶ 2 x Wi-Fi / Bluetooth antenna
- ▶ Antenna cap
- ▶ Connection cable for power supply

2.5 Construction

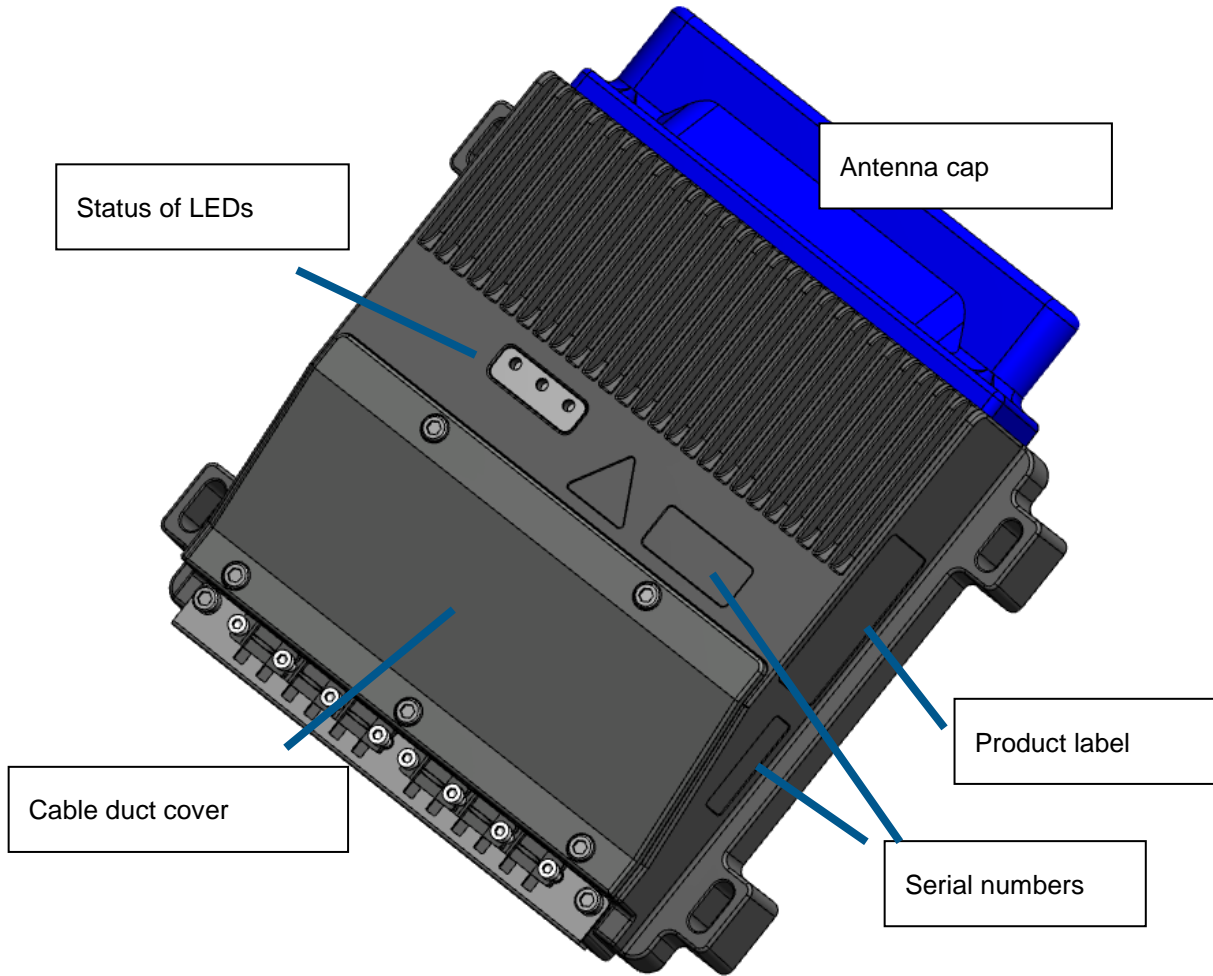

2.6 Status of LEDs

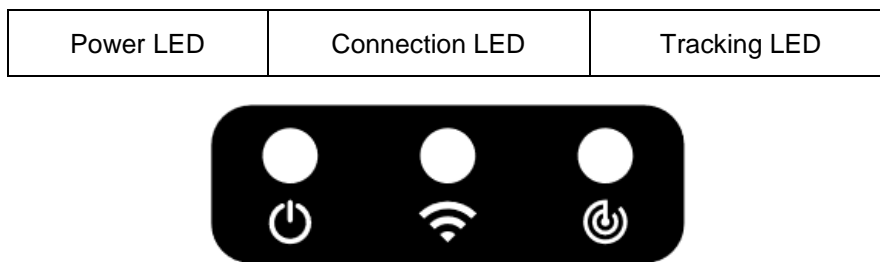

The following table gives the standard configuration of the status LEDs. The specific response can be modified via the application software.

LED	Color	Flashing pattern	Meaning
Power	Green	ON	Supply voltage is available and ignition signal is present

Connection	Yellow	ON	Network connection established
Tracking	Blue	Regular flashing	Tracking running

2.7 Designation and labeling

Name plate

The nameplate is situated in a protected position on the side of the ZenoCCU. For the purposes of device identification, it must remain legible and it not permitted to have anything affixed over it.



Serial number

The serial number is affixed to the housing in two places. One is located in a protected position on the side of the housing. The other is in an easily visible location on the top.

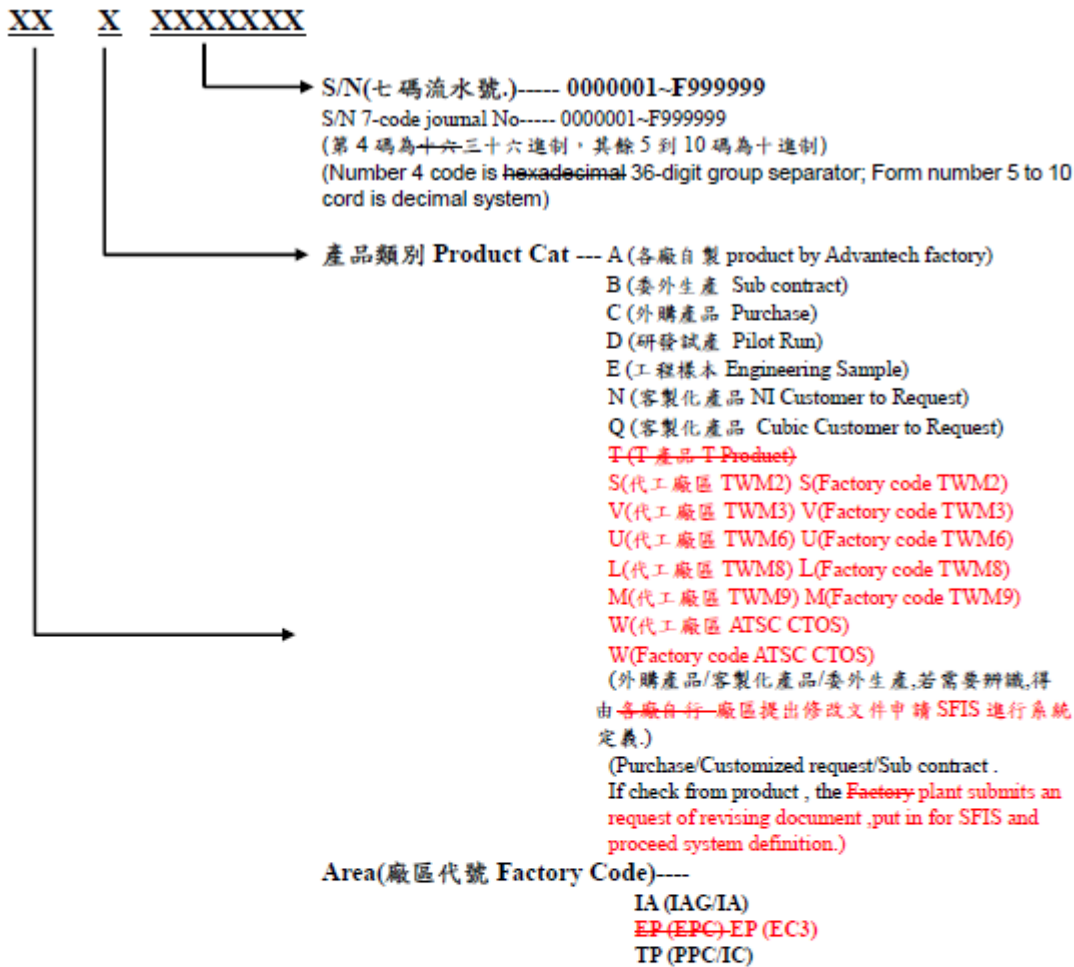

- HM (PPC/ICIAC/AWS)
- CD (ADMC)
- AK (AKMU 1)
- KS (AKMU 2)
- ES (ATDC: Advantech Taiwan Design Center)
- KN (AKMU4)
- KU (AKMU5)
- ~~EC (EC2)-EC (EC3)~~
- LK(EC3)
- GS(PPC2)

"Caution: hot" sticker**WARNING****Hot surfaces**

The surfaces of the ZenoCCU can reach a surface temperature of over 70°C depending on the environmental conditions and operating point.

3 Preparing the product

3.1 Unpacking the device

- ▶ Open the packaging carefully to prevent damaging the device
- ▶ Retain the packaging material (for any onward transport or returns)
- ▶ Check the shipment for completeness and any possible damage
- ▶ Always keep the supplied manuals and documents

3.2 Transport

**CAUTION**

Risk of injury due to weight and sharp-edged parts.

The ZenoCCU may fall down and cause injuries due to its weight. The strain relief rail can have sharp edges and cause cutting injuries.

- ▶ Always hold the ZenoCCU by the housing with both hands.
- ▶ Never use the antenna cap as a handle. It can break due to the weight involved.
- ▶ Do not grip the ZenoCCU on the strain relief plate.
- ▶ Use the assistance of a second person for installation work
- ▶ For onward transport or return, use suitable packaging material to ensure that the device is not damaged

3.3 Storage

The ZenoCCU can also be stored in the transport packaging within the specified storage temperature range.

4 Technical data

4.1 General

Article number	XXXXXXX
Housing	Aluminum pressure casting

	L x W x H (mm): 200 x 210 x 70 without antenna cap L x W x H (mm): 225 x 210 x 70 with antenna cap
Weight	XXX g
Operating temperature	-20 °C to +45 °C
Storage temperature	XXX to XXX
Humidity	XXXXXX
Power supply	9 - 60V DC
System performance	60 W
Protection class	IP65
Mechanical stability	EN 60721-3-5 class 5M3
CPU	INTEL Atom E3845 Quadcore 1.9GHz
RAM	4GB
Mass storage	32GB EMMC (pSLC)
Interfaces	3x 10 / 100 / 1000Mbit Ethernet 2x Power over Ethernet Class 2 1x USB 3.0 1x USB2.0 with high retention connection 2x RS232 1x CAN (isolated) 4x digital IO 4x analog input (0-10V, 0-20mA)
Digital input	Max. input voltage: 30V Minimum high level voltage: 11V
Digital output	High level output voltage: 12V, 24V (depending on the sensor supply voltage) Maximum output current per pin: 150mA
Analog input	Max input voltage: 13V Voltage input measuring range: 0..10V DC Current input measuring range: 0..20mA
Power supply for sensors	Max. 24W

4.2 Device dimensions

Placeholder

4.3 Interfaces

The following figure shows the interior of the cable duct as well as the sticker within the cable duct.

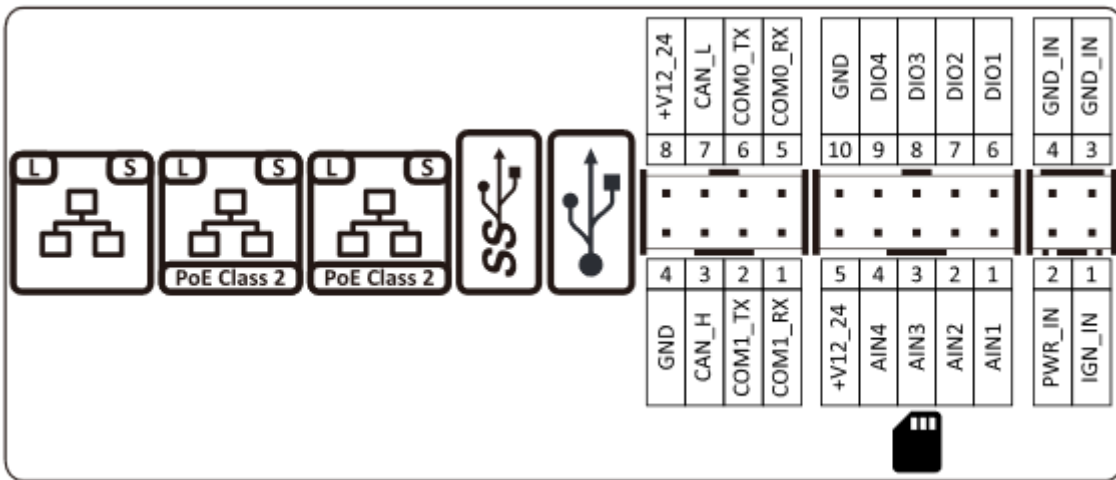
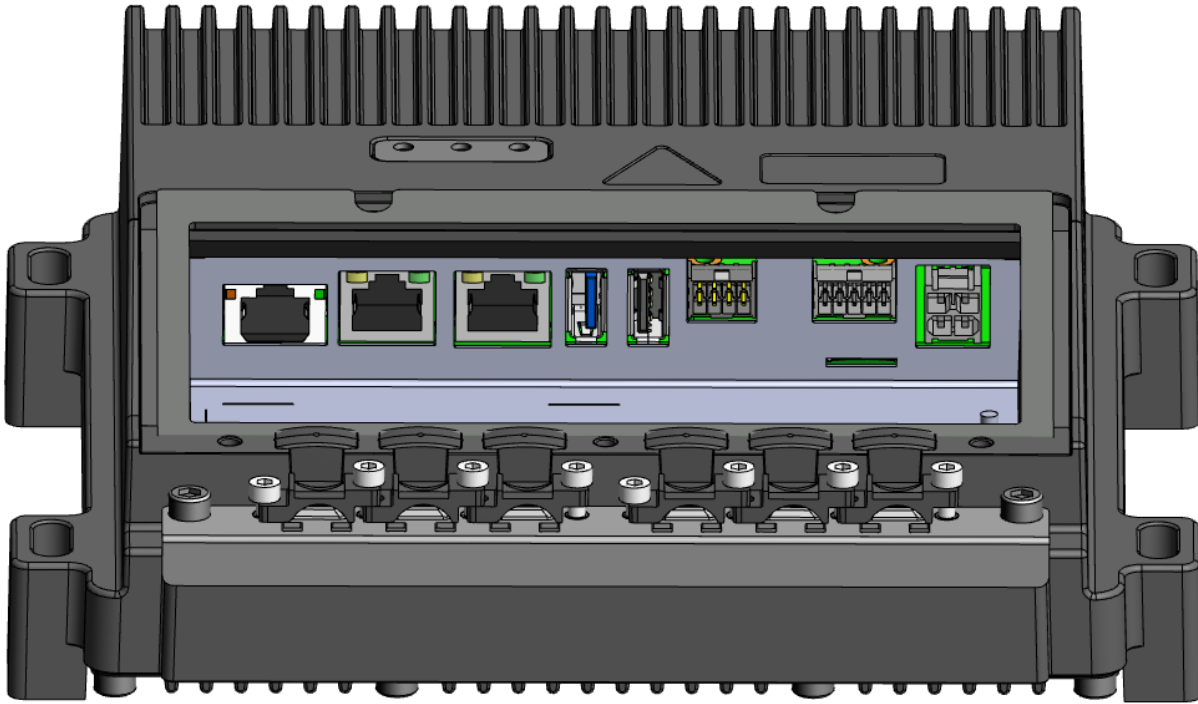

Interface description from left to right:

Designation	Description
LAN Port 1	10 / 100 / 1000 Mbit
LAN Port 2	10 / 100 / 1000 Mbit with Power over Ethernet Class 2
LAN Port 3	10 / 100 / 1000 Mbit with Power over Ethernet Class 2

USB 3.0	USB 3.0 Super Speed Maximum current 900mA
USB 2.0	USB 2.0 high retention connection Maximum current 400mA Min. pull-off force 15N
Communication port	2x EIA 232 1x CAN galvanically separated
Sensor interface	<ul style="list-style-type: none"> ➤ 4x analog input (current or voltage input) <ul style="list-style-type: none"> ○ Max input voltage: 13V ○ Voltage input measuring range: 0..10V DC ○ Current input measuring range: 0..20mA ➤ 4x digital IO (configurable) <ul style="list-style-type: none"> ○ Digital In <ul style="list-style-type: none"> ○ Max. input voltage: 30V ○ Minimum high level voltage: 11V ○ Digital Out <ul style="list-style-type: none"> ○ High level output voltage: 12V, 24V (depending on the sensor supply voltage) ○ Maximum output voltage per pin: min. 150mA
Plug-in unit for SD card	Plug-in unit direction with contact surfaces upward Card format microSD Max. memory size 64 GB
Plug for power supply	Input voltage 9-60V DC Max. system performance 60W

4.4 Antennae

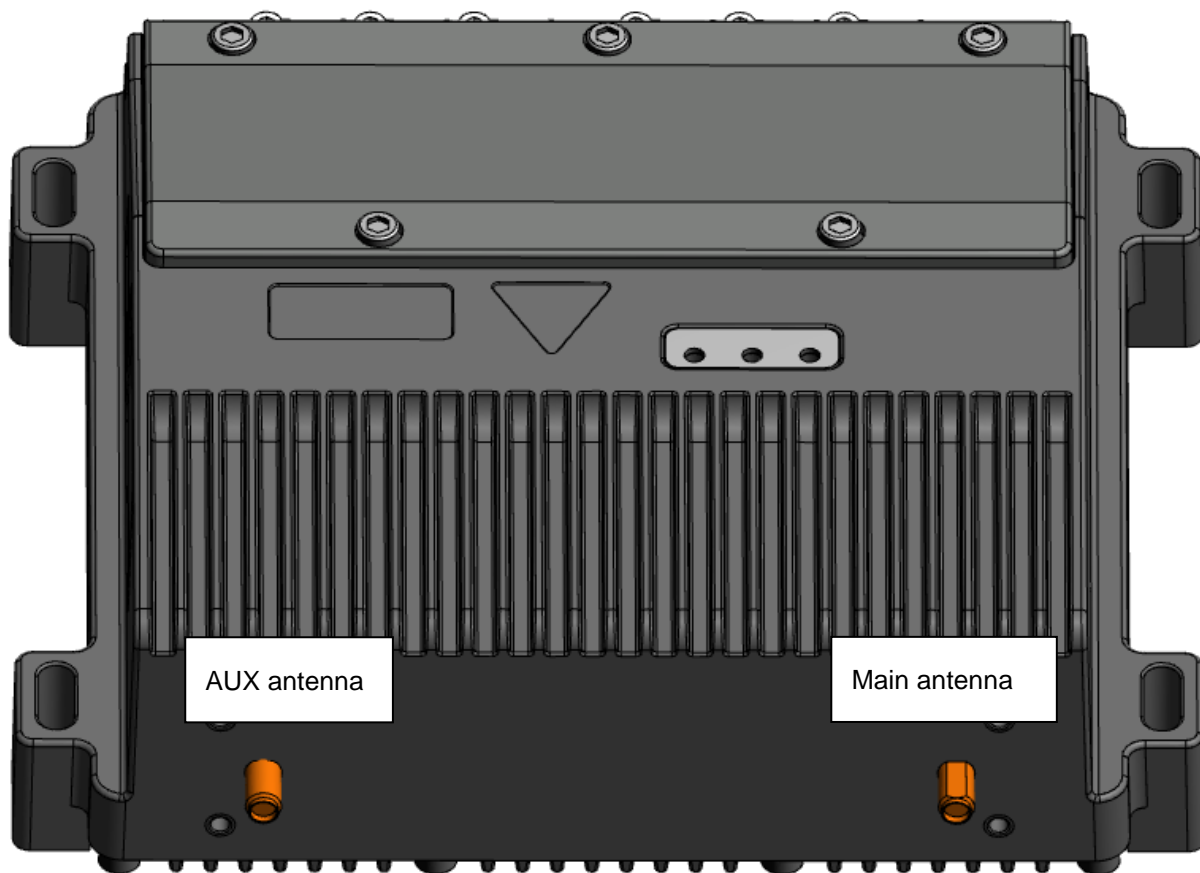

5 Mechanical mounting

The ZenoCCU can be fastened using 4 x M6 screws with a minimal length of 35 mm. In uneven locations, the mounting can be carried out with 3 screws.

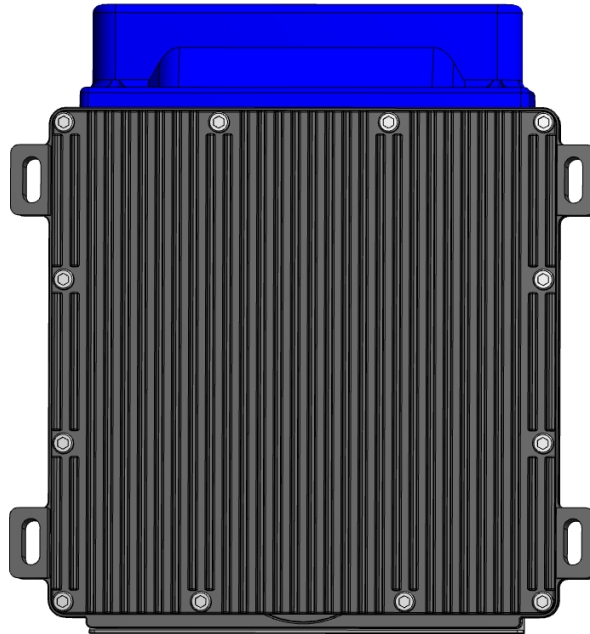

5.1 Safety notice



WARNING

Risk of injury and damage due to improper commissioning

- Observe the safety instructions
- Observe the notes on intended use

NOTICE: Physical damage

Specialist mechanical knowledge is required for correct mounting of the device.

- ▶ Use suitable mounting material (screws and washers).
 - ▶ There are no fixing screws included in the scope of delivery.
 - ▶ The fixing screws must be selected according to the mounting location
- ▶ Use a suitable tool
- ▶ There must be a distance of XXmm between the cooling fins on the underside and the fixture
- ▶ Mounting location and installation direction

Recommended sequence of installation steps

Requirement: The deployed system must be correctly prepared.

1. Find a suitable mounting position for the ZenoCCU.
2. Secure the ZenoCCU at the installation site.
3. Connect the external accessories to the ZenoCCU.
4. Install an easily accessible disconnecting device such as a switch close to the device.
5. Connect the power supply
6. Seal the cable passages with sealing grommets and dummy grommets.

7. Fasten the strain relief devices
8. Seal the cable cover

**WARNING****Hazardous voltage, electric shock from contact with live parts.**

- Do not put the ZenoCCU into operation if it has signs of damage.
- Do not open or modify the ZenoCCU.
- Only connect or disconnect electrical connections when the device is in a de-energized state.

Observe the manufacturer specifications for the usage object on which the ZenoCCU is installed.

- Observe the requirements of the manufacturer for the attachment of auxiliary devices and the connection of auxiliary consumers.
- This is particularly important when welding or drilling supporting parts.
- Observe the manufacturer's instructions for connecting additional loads, for example, in conjunction with an emergency shut-off switch.

Risk of accident due to unstable attachment of the ZenoCCU

- When installing the ZenoCCU, ensure that if the bracket breaks (e.g. because of a stress fracture) no one will be injured.
- Alternatively, please put appropriate safety measures in place (e.g. attach an additional security cable)

Risk of accident due to limited field of view of the driver

- Never mount the ZenoCCU such that the driver is restricted in terms of viewing range and freedom of movement.
- This also applies to additional devices and cables

**Caution****Sharp-edged parts**

The strain relief rail of the ZenoCCU can have sharp edges and cause cutting injuries.

- Do not hold by the strain relief plate.

**WARNING****Radio wave emission in the vicinity of persons**

- Install the ZenoCCU so that persons maintain a minimum distance of 20 cm to the antenna.
- Observe the applicable regulations for your deployment location/country with regard to frequencies and the maximum permissible transmitting power. Responsibility for this lies with the company operating the ZenoCCU. The regulatory authorities in the relevant country can provide information on this.

**WARNING**

Radio wave emission in the vicinity of persons

- ▶ Install the ZenoCCU so that persons maintain a minimum distance of 20 cm to the antenna.
- ▶ Observe the applicable regulations for your deployment location/country with regard to frequencies and the maximum permissible transmitting power. Responsibility for this lies with the company operating the ZenoCCU. The regulatory authorities in the relevant country can provide information on this.

6 Connecting the cables and cable cover

6.1 Preparing the cables, cable grommets and dummy grommets

Cable sealing set and strain relief (included as standard)

Kabeltüllen (Öffnungen unterschiedlich groß)	Blindtüllen	Kabelschellen	Befestigungsschrauben
			

- ▶ Correctly lay out ready all cables that are to be connected.
- ▶ Check the cable diameters. The cable grommet used depends on the cable diameter.

NOTICE

The cable grommet must completely surround the cable. The opening of the cable grommet must be slightly smaller than the cable diameter. If the opening is too large or too small, the sealing of the device will not be ensured.

6.2 Plugging in the power supply cable

The power supply plug should be locked when inserted. The lock must be pointing upward when inserted.

6.3 Securing the ground using ring tongue to the ground bolt

6.4 Securing the power supply cable to the strain relief rail

- ▶ Place the power supply cable, with cable grommet, in the strain relief rail cable passage
- ▶ Secure the cable against slipping using a cable tie if required
- ▶ Place one cable clip on the power supply cable
- ▶ Secure the cable clip to the strain relief rail using 2 mounting screws (M3x10)
- ▶ Tighten up the mounting screws in opposite pairs

NOTICE

Tighten the mounting screws sufficiently but make sure not to pinch the cable. Otherwise, the cables may break or the insulation may be damaged.

...

6.5 Connecting further cables

NOTICE: Physical damage

Only connect accessories that have been checked by Zeno Track and approved for the ZenoCCU.

Procedure as described for the power supply cable:

- ▶ Insert cable
- ▶ Fit the appropriate cable grommet
- ▶ Insert into the cable passage
- ▶ If necessary, secure cable using cable tie
- ▶ Secure using cable clip and screws to the strain relief rail

6.6 Closing off unused cable openings

All unused cable passages must be sealed with dummy grommets so that they are air-tight.

6.7 Fitting the cable cover

- ▶ Place the cable cover into the cut-out section in the housing
- ▶ Loosely screw the M3x5 screws into the cable cover holes

...

7 Electrical installation

7.1 Safety notice

**WARNING**

Electrical shock due to lack of disconnecting device.

The ZenoCCU is not equipped with disconnecting devices that are accessible from the outside; it does not have switches.

To enable the device to be quickly disconnected from the power supply in emergency situations:

- ▶ Install an easily accessible disconnecting device close to the device.
- ▶ Make sure that the disconnecting device disconnects all power supply lines.

**WARNING****Electrical shock due to insufficient emergency shut-off**

If the emergency stop switch of the object being used does not switch off the ZenoCCU, there is a risk of electric shock.

- ▶ Install the ZenoCCU and the emergency stop switch so that the DLT-V4108 also switches off when the emergency stop switch is operated.

7.2 Connection to the power supply

7.2.1 Electrical connection to vehicles

**WARNING****Electric shock, fire due to incorrect cable routing or insufficient grounding.**

- ▶ This product is intended to be supplied by an UL certified power supply or dc source suitable for use at minimum T_{ma} 45 degree C whose output meets SELV or ES1 and is rated 9-60Vdc, 7.2-1.1A min., if you need further assistance, please contact Zeno Track for further information
- ▶ Ensure to connect the power cord to a socket-outlet with earthing connection
- ▶ Use only original power supply cables from Zeno Track.
- ▶ Make sure that the power supply cables are run without kinks and are mechanically protected (securely protected against crushing and abrading).
- ▶ The DC+ - connecting cable must be protected by a maximum 30 A T fuse.
- ▶ The ignition connecting cable must be protected by a fuse of the following type: 5x20 mm T 125 mA L / 250 V, for example Wickmann195-125 mA / 250 V.
- ▶ Observe correct voltage ranges.
- ▶ Ensure that power supply cable is fused correctly.
- ▶ Observe the labeling on the cable and connect the power supply cable with the correct polarity.
- ▶ Cut the power supply cable to the minimum length. This avoids tangled cables and improves the quality of the power supply.
- ▶ Connect the power supply cable to a suitable place. Ensure that the connecting cable has an adequate cross section and ampacity at the connection point.

Observe the following when connecting/removing external devices:

- Only connect accessories that have been checked by Zeno Track and approved for the ZenoCCU.
- The DLT -V4108 may not be connected to the power supply if external devices are being connected/removed (not applicable for USB devices). Otherwise considerable damage could be caused to both the DLT -V4108 and the peripheral devices.
- Make sure that peripherals with their own power supply are either switched on at the same time as the DLT -V4108 or after the start of the DLT -V4108.
- Otherwise, you must ensure that a backflow from the external device to the DLT -V4108 cannot take place.
- Only power up the DLT -V4108 when all devices have been connected and the DLT-V83 has been closed correctly (remember the cable cover!).

7.2.2 Observe the potential ratios

In the ZenoCCU, the logic ground and the shield ground are firmly connected to each other. Logic ground is the ground (GND) used to supply the internal parts and components (e.g. CPU). All cable shields and the housing are connected to shield ground. As the power supply unit of the ZenoCCU is not galvanically separated, all ground connections are laid on DC- of the forklift. The chassis of some forklifts is on DC+. This may cause malfunctions or irreparable damage. In this case, the ZenoCCU must be mounted with isolation. Always attach ring tongue of the supply cable to the provided ground bolt situated on the connector panel.



The other end of the yellow-green power supply cable must be connected to the vehicle's chassis. Connect the power supply cable of the ZenoCCU as directly as possible to the battery and not to power supply lines with a great deal of interference (e.g. the engine power supply) or otherwise affected by consumers. Connecting the ZenoCCU to large electrical loads, such as converters for the forklift motor may result in random restarts, malfunctions and/or irreparable damage to the device.

If you want to connect devices fed by other power sources (e.g. printers), be sure to power up the peripheral devices at the same time or after the ZenoCCU; otherwise, you may encounter start-up problems, malfunctions or even irreparable damage to the device.

7.2.3 Electrically isolated installation

Due to a variety of technical properties of forklifts and forklift trucks, it can be necessary to electrically isolate the ZenoCCU from the chassis of the vehicle to prevent malfunctions. The necessity of this must be studied on a case-by-case basis, however, it is recommended for vehicles with potential-free chassis.

For example, using rubber buffers ensures that the ZenoCCU has no electrically conducting connection to the vehicle chassis. Moreover, the peripheral equipment and its cabling must be attached electrically isolated. If external antennas are being used, you must ensure that the antennas are isolated at the mounting point on the vehicle chassis.

7.3 Securing the ground using ring tongue to the ground bolt

8 Operation / usage

NOTICE: Physical damage

Incorrect operation can cause damage to and downtimes on the ZenoCCU and the connected overall system. Operators of the ZenoCCU must be trained in the handling of the device.

Different temperature and air humidity.

If the ZenoCCU is alternately used between very different temperatures and air humidity conditions, condensation can occur in the and on the device.

To prevent damage to the device, allow sufficient acclimation time before using (moisture must evaporate).

Cable

- ▶ Ensure that there are no objects lying on the cable, and that no-one can step on or trip over the cables.

- ▶ When disconnecting a cable, always unplug at the connection plug, not on the cable itself.
- ▶ Always keep the connection plug when unplugging it to avoid damage to the pins.
- ▶ When connecting a cable, align the connection plug correctly.
- ▶ If strain relief devices are fitted, these must be used.

Overvoltage on the ZenoCCU when charging the battery of the connected system.

While the battery of the connected system is being charged, the ZenoCCU must be disconnected from this battery. Or it must be ensured that the maximum permitted input voltage of the ZenoCCU is not exceeded.

8.1 Starting and shutting down

The ZenoCCU starts depending on the setting when applying the supply voltage or when switching on the ignition signal.

After switching off the ignition, the system continues to run for an adjustable time until the system is shut down.

NOTICE: Physical damage

Do not disconnect the ZenoCCU from the power supply during ongoing operation.

8.2 Status display

The status display is carried out on the device solely via the status LEDs on the top of the housing. For further details, see chapter 2.

8.3 Access

In the standard configuration, each ZenoCCU creates a Wi-Fi access point with the SSID

ZenoCCU-<Serial number>. e.g.: ZenoCCU-???????

<Serial number> corresponds here to the number affixed to the device.

For access it is possible to connect to the access point, where the computer is assigned an IP address by the ZenoCCU computer.

Wi-Fi connection data

- ▶ Encryption: WPA2
- ▶ Default password: 1223334444
- ▶ IP address of the ZenoCCU: 172.26.20.1

Ethernet connection data

- ▶ DHCP pre-configured, after timeout the IP address 192.168.0.2 on the first Ethernet port

The configuration is carried out via the remote desktop (uses the VNC protocol) or the Pilot Pro Web UI.

Default password for the VNC connection: Qwert_01

8.4 Settings

Basic and advanced configurations can be found in the commissioning instructions for the controller software ().

8.5 Accessories

Accessories	Article number
Sensor cable (5m) (for connecting up to 4 external sensors)	10304025
Ethernet cable (5m)	90108025
Power supply / ignition cable (5m)	
24V power adapter	Remove if necessary
ZenoSIB with 4 M12 connections	90208100

8.6 Antennae

Integrated antennae

2 x under the antenna cap for 2.4 GHz and 5 GHz.

9 Servicing and maintenance

Only the manufacturer and its authorized service centers may perform the following measures on the device:

- ▶ Open the device
- ▶ Repairs
- ▶ Modifications
- ▶ Replacing components

9.1 Cleaning



WARNING

Hazardous voltage, electric shock from contact with live parts when cleaning the device

To prevent an electric shock:

- ▶ Switch off the ZenoCCU before cleaning.
- ▶ Disconnect from the power supply.
- ▶ Disconnect connected accessories.

NOTICE: Physical damage

Cleaning the housing

- ▶ Clean the housing with a damp cloth.
- ▶ Never use chemical solvents to clean the touchscreen.
- ▶ Do not use acidic or alkaline solutions.

9.2 Inspection and repair



WARNING

Risk of accident due to unstable attachment of the ZenoCCU to vehicles

- If the attachment of the ZenoCCU becomes loose and breaks during motion, this can lead to severe accidents.
- Check at regular intervals to ensure that the mounting screws on the ZenoCCU are not loose.

Never open the equipment. For safety reasons, the equipment should be opened only by qualified skilled person.



CAUTION

Risk of explosion if the battery is replaced by an incorrect type

10 End-of-life device disposal

xxxx

11 Technical customer support

Please contact your distributor,
sales representative or customer service for technical support.

Please have the following information available:

- ▶ Product name
- ▶ Serial number
- ▶ Description of the connected accessory
- ▶ General description of the problem

Zeno Track Service and Support

www.zenoway.com

email: support@zenotrack.com

Tel.: +43 1 797 22 - 2100

Manufacturer address

Zeno Track GmbH

Geiereckstrasse 6

A-1110 Wien | Vienna

Österreich | Austria

Warranty

?????

© !

Information in this document is subject to change – also without prior notice. Zeno Track GmbH assumes no liability for technical inaccuracies, typographic errors or faults in this document. DLoG GmbH accepts no liability for damage caused directly or indirectly by the delivery, performance or use of this document.

12 ??Form for device returns??

Federal Communication Commission Interference Statement

This device complies with Part 15 of the FCC Rules. Operation is subject to the following two conditions: (1) This device may not cause harmful interference, and (2) this device must accept any interference received, including interference that may cause undesired operation.

NOTE: This equipment has been tested and found to comply with the limits for a Class A digital device, pursuant to part 15 of the FCC Rules. These limits are designed to provide reasonable protection against harmful interference when the equipment is operated in a commercial environment. This equipment generates, uses, and can radiate radiofrequency energy and, if not installed and used in accordance with the instruction manual, may cause harmful interference to radio communications. Operation of this equipment in a residential area is likely to cause harmful interference in which case the user will be required to correct the interference at his own expense.

FCC Caution: Any changes or modifications not expressly approved by the party responsible for compliance could void the user's authority to operate this equipment.

This transmitter must not be co-located or operating in conjunction with any other antenna or transmitter.

This device meets all the other requirements specified in Part 15E, Section 15.407 of the FCC Rules.

Radiation Exposure Statement:

This equipment complies with FCC radiation exposure limits set forth for an uncontrolled environment. This equipment should be installed and operated with minimum distance 20cm between the radiator & your body.

FOR COUNTRY CODE SELECTION USAGE (WLAN DEVICES)

Note: The country code selection is for non-US model only and is not available to all US model. Per FCC regulation, all WiFi product marketed in US must be fixed to US operation channels only.