



FCC Test Report

Equipment : M2.COM LoRa IoT Node
Brand Name : Advantech
Model No. : WISE-1510
FCC ID : M82-WISE1510
Standard : 47 CFR FCC Part 15.247
Frequency : 902 MHz – 928 MHz
Function : Point-to-multipoint; Point-to-point
Applicant : Advantech Co., Ltd.
No.1, Alley 20, Lane 26, Rueiguang Rd., Neihu District, Taipei City, Taiwan, R.O.C.
Manufacturer : Advantech Co., Ltd.
No.1, Alley 20, Lane 26, Rueiguang Rd., Neihu District, Taipei City, Taiwan, R.O.C.

The product sample received on Dec. 28, 2016 and completely tested on Apr. 14, 2017. We, SPORTON, would like to declare that the tested sample has been evaluated in accordance with the procedures given in ANSI C63.10-2013 and shown compliance with the applicable technical standards.

The test results in this report apply exclusively to the tested model / sample. Without written approval of SPORTON INTERNATIONAL INC., the test report shall not be reproduced except in full.

Cliff Chang
SPORTON INTERNATIONAL INC.





Table of Contents

- 1 GENERAL DESCRIPTION6**
- 1.1 Information.....6
- 1.2 Testing Applied Standards7
- 1.3 Testing Location Information7
- 1.4 Measurement Uncertainty8
- 2 TEST CONFIGURATION OF EUT9**
- 2.1 Test Channel Mode9
- 2.2 The Worst Case Measurement Configuration.....10
- 2.3 EUT Operation during Test10
- 2.4 Accessories11
- 2.5 Support Equipment.....11
- 2.6 Test Setup Diagram12
- 3 TEST RESULT15**
- 3.1 AC Power-line Conducted Emissions15
- 4 TRANSMITTER TEST RESULT – DTS.....17**
- 4.1 DTS Bandwidth17
- 4.2 Maximum Conducted Output Power18
- 4.3 Power Spectral Density20
- 4.4 Emissions in Non-restricted Frequency Bands22
- 4.5 Emissions in Restricted Frequency Bands.....23
- 5 TRANSMITTER TEST RESULT – HYBRID27**
- 5.1 20dB Bandwidth and Carrier Frequency Separation27
- 5.2 Maximum Conducted Output Power28
- 5.3 Power Spectral Density30
- 5.4 Number of Hopping Frequencies and Hopping Bandedge32
- 5.5 Time of Occupancy (Dwell Time)33
- 5.6 Emissions in Non-restricted Frequency Bands34
- 5.7 Emissions in Restricted Frequency Bands.....35
- 6 TEST EQUIPMENT AND CALIBRATION DATA.....37**

APPENDIX A. TEST RESULTS OF AC POWER-LINE CONDUCTED EMISSIONS

APPENDIX B. TEST RESULTS OF DTS BANDWIDT_ LORA-500KHZ

APPENDIX C. TEST RESULTS OF MAXIMUM CONDUCTED OUTPUT POWER_ LORA-500KHZ

APPENDIX D. TEST RESULTS OF POWER SPECTRAL DENSITY_ LORA-500KHZ

**APPENDIX E. TEST RESULTS OF EMISSIONS IN NON-RESTRICTED FREQUENCY BANDS_
LORA-500KHZ**



APPENDIX F. TEST RESULTS OF EMISSIONS IN RESTRICTED FREQUENCY BANDS_ LORA-500KHZ

**APPENDIX G. TEST RESULTS OF 20DB BANDWIDTH AND CARRIER FREQUENCY SEPARATION_
LORA-125KHZ**

APPENDIX H. TEST RESULTS OF MAXIMUM CONDUCTED OUTPUT POWER_ LORA-125KHZ

APPENDIX I. TEST RESULTS OF POWER SPECTRAL DENSITY_ LORA-125KHZ

**APPENDIX J. TEST RESULTS OF NUMBER OF HOPPING FREQUENCIES AND HOPPING
BANDEDGE_ LORA-125KHZ**

APPENDIX K. TEST RESULTS OF TIME OF OCCUPANCY (DWELL TIME) _LORA-125KHZ

**APPENDIX L. TEST RESULTS OF EMISSIONS IN NON-RESTRICTED FREQUENCY
BANDS_ LORA-125KHZ**

APPENDIX M. TEST RESULTS OF EMISSIONS IN RESTRICTED FREQUENCY BANDS_ LORA-125KHZ

APPENDIX N. TEST PHOTOS

PHOTOGRAPHS OF EUT V01



Summary of Test Result

Conformance Test Specifications				
Report Clause	Ref. Std. Clause	Description	Limit	Result
1.1.2	15.203	Antenna Requirement	FCC 15.203	Complied
3.1	15.207	AC Power-line Conducted Emissions	FCC 15.207	Complied
DTS Test Method Performed				
4.1	15.247(a)	DTS Bandwidth	≥500kHz	Complied
4.2	15.247(b)	Maximum Conducted Output Power	Power [dBm]:30	Complied
4.3	15.247(e)	Power Spectral Density	PSD [dBm/3kHz]:8	Complied
4.4	15.247(d)	Emissions in Non-restricted Frequency Bands	Non-Restricted Bands: >30 dBc	Complied
4.5	15.247(d)	Emissions in Restricted Frequency Bands	Restricted Bands: FCC 15.209	Complied
Hybrid Test Method Performed				
5.1	15.247(a)	20dB Bandwidth	15.247(a)	Complied
5.1	15.247(a)	Carrier Frequency Separation	15.247(a)	Complied
5.2	15.247(b)	Maximum Conducted Output Power	15.247(b)	Complied
5.3	15.247(e)	Power Spectral Density	PSD [dBm/3kHz]:8	Complied
5.4	15.247(a)	Number of Hopping Frequencies and Hopping Band edge	15.247(a)	Complied
5.5	15.247(a)	Time of Occupancy (Dwell Time)	15.247(a)	Complied
5.6	15.247(d)	Emissions in Non-restricted Frequency Bands	15.247(d)	Complied
5.7	15.247(d)	Emissions in Restricted Frequency Bands	Restricted Bands: FCC 15.209	Complied



Revision History

Report No.	Version	Description	Issued Date
FR690609	Rev. 01	Initial issue of report	May 11, 2017

1 General Description

1.1 Information

1.1.1 RF General Information

Frequency Range (MHz)	LoRa Mode	Ch. Frequency (MHz)	Channel Number
902-928	LoRa-500kHz	903.0-914.2	64-71 [8]
		923.3-927.5	0-7 [8]
	LoRa-125kHz	902.3-914.9	0-63 [64]

Band	LoRa Mode	BWch	Nant
902-928MHz	LoRa-500kHz	6MhZ 600kHz	1
902-928MHz	LoRa-125kHz	200kHz	1

Note:

- ◆ 900M is the 900MHz band (902-928MHz)
- ◆ LoRa-125kHz uses as a hybrid system using DTS & FHSS
- ◆ LoRa-500kHz uses as a DTS
- ◆ LoRa-125kHz, LoRa-500kHz uses Chirp Spread Spectrum (CSS) modulation
- ◆ BWch is the channel separation
- ◆ Nss-Min is the minimum number of spatial streams.
- ◆ Nant is the number of outputs. e.g., 2(2, 3) means have 2 outputs for port 2 and port 3. 2 means have 2 outputs for port 1 and port 2.
- ◆ The EUT has two transmission modes for data transmissions as described below:
 1. LoRa-125kHz Hybrid (FHSS + DTS)
 2. LoRa-500kHz DTS
 Testing was performed in accordance with the applicable FCC requirement for each of two transmission modes.

1.1.2 Antenna Information

Ant.	Brand	Model Name (P/N)	Antenna Type	Connector	Gain (dBi)	Remark
1	SInBOn	TH-915i	Dipole Antnna	SMA (Male)	1.8	1TX/1RX

1.1.3 Mode Test Duty Cycle

Mode	DC	DCF(dB)
LoRa-500kHz	0.983	0.074
LoRa-125kHz	1	0

1.1.4 EUT Operational Condition

EUT Power Type	From host system
-----------------------	------------------



1.2 Testing Applied Standards

According to the specifications of the manufacturer, the EUT must comply with the requirements of the following standards:

- ◆ 47 CFR FCC Part 15
- ◆ ANSI C63.10-2013
- ◆ FCC KDB 558074 D01 v03r05
- ◆ FCC Public Notice DA 00-705
- ◆ FCC KDB 412172 D01 v01r01

1.3 Testing Location Information

Testing Location		
<input type="checkbox"/>	HWA YA	ADD : No. 52, Hwa Ya 1st Rd., Kwei-Shan Hsiang, Tao Yuan Hsien, Taiwan, R.O.C. TEL : 886-3-327-3456 FAX : 886-3-318-0055
<input checked="" type="checkbox"/>	JHUBEI	ADD : No.8, Lane 724, Bo-ai St., Jhubei City, HsinChu County 302, Taiwan, R.O.C. TEL : 886-3-656-9065 FAX : 886-3-656-9085

Test Condition	Test Site No.	Test Engineer	Test Environment	Test Date
RF Conducted	TH01-CB	Serway Li	20°C / 45%	Mar. 30, 2017
Radiated	03CH01-CB	Brian Sun, Justin Lin	22°C / 54%	Feb. 18, 2017 Apr. 14, 2017
AC Conduction	CO01-CB	Ryo Fan	23°C / 60%	Feb. 17, 2017

Test site Designation No. TW0006 with FCC.
Test site registered number IC 4086D with Industry Canada.



1.4 Measurement Uncertainty

ISO/IEC 17025 requires that an estimate of the measurement uncertainties associated with the emissions test results be included in the report. The measurement uncertainties given below are based on a 95% confidence level (based on a coverage factor (k=2))

Test Items	Uncertainty	Remark
Conducted Emission (150kHz ~ 30MHz)	3.2 dB	Confidence levels of 95%
Radiated Emission (30MHz ~ 1,000MHz)	3.6 dB	Confidence levels of 95%
Radiated Emission (1GHz ~ 18GHz)	3.7 dB	Confidence levels of 95%
Radiated Emission (18GHz ~ 40GHz)	3.5 dB	Confidence levels of 95%
Conducted Emission	1.7 dB	Confidence levels of 95%
Output Power Measurement	1.33 dB	Confidence levels of 95%
Power Density Measurement	1.27 dB	Confidence levels of 95%
Bandwidth Measurement	9.74×10^{-8}	Confidence levels of 95%



2 Test Configuration of EUT

2.1 Test Channel Mode

For LoRa-500kHz

LoRa_Nss1_1TX	-
903MHz	20
907.8MHz	20
914.2MHz	20
923.3MHz	20
925.1MHz	20
927.5MHz	20

For LoRa-125kHz

Mode	Power Setting
LoRa_Nss1_1TX	-
902.3MHz	20
908.5MHz	20
914.9MHz	20

Note:

- ◆ Test Data Rate:
125k: 0.98kbps
500k(903~914.2MHz): 12.5kbps
500k(923.3~927.5MHz): 0.98kbps

2.2 The Worst Case Measurement Configuration

The Worst Case Mode for Following Conformance Tests	
Tests Item	AC power-line conducted emissions
Condition	AC power-line conducted measurement for line and neutral
Operating Mode	Normal Link

The Worst Case Mode for Following Conformance Tests	
Tests Item	DTS Bandwidth Maximum Conducted Output Power Power Spectral Density 20dB Bandwidth Carrier Frequency Separation Maximum Conducted Output Power Number of Hopping Frequencies and Hopping Bandedge Time of Occupancy (Dwell Time) Emissions in Non-restricted Frequency Bands
Test Condition	Conducted measurement at transmit chains

The Worst Case Mode for Following Conformance Tests	
Tests Item	Emissions in Restricted Frequency Bands
Test Condition	Radiated measurement If EUT consist of multiple antenna assembly (multiple antenna are used in EUT regardless of spatial multiplexing MIMO configuration), the radiated test should be performed with highest antenna gain of each antenna type.
Operating Mode < 1GHz	Normal Link
1	EUT in X axis
2	EUT in Y axis
3	EUT in Z axis
For operating mode 3 is the worst case and it was record in this test report.	
Operating Mode > 1GHz	CTX
The EUT was performed at X axis, Y axis and Z axis position for Radiated emission test, and the worst case was found at Z axis. So the measurement will follow this same test configuration.	
1	EUT in Z axis (LoRa-500KHz / 903~914.2MHz)
2	EUT in Z axis (LoRa-500KHz / 923.3~927.5MHz)
3	EUT in Z axis (LoRa-125KHz / 902.3-914.9 MHz)

2.3 EUT Operation during Test

For CTX Mode:

The EUT was programmed to be in continuously transmitting mode.

For Normal Link:

During the test, the EUT operation to normal function.



2.4 Accessories

N/A

2.5 Support Equipment

For Test Site No: CO01-CB

Support Equipment				
No.	Equipment	Brand Name	Model Name	FCC ID
1	NB	DELL	E6430	DoC
2	Mouse	Logitech	M-U0026	DoC
3	Earphone	SHYARO CHI	MIC-04	DoC
4	Fixture1	Advantech	WISE-ES20	DoC
5	Fixture2	Advantech	WISE-ED30	DoC
6	Fixture3	Advantech	WISE-DB1500	DoC

For Test Site No: 03CH01-CB (below 1GHz)

Support Equipment				
No.	Equipment	Brand Name	Model Name	FCC ID
1	Notebook	DELL	E4300	DoC
2	Mouse	Logitech	M-U0026	DoC
3	Earphone	SHYARO CHI	MIC-04	N/A
4	Fixture1	Advantech	WISE-ED30	N/A
5	Fixture2	Advantech	WISE-ED20	N/A
6	Fixture3	Advantech	WISE-DB1500	N/A

For Test Site No: 03CH01-CB (above 1GHz)

Support Equipment				
No.	Equipment	Brand Name	Model Name	FCC ID
1	Fixture2	Advantech	WISE-ED20	N/A
2	Notebook	DELL	E4300	DoC

For Test Site No: TH01-CB

Support Equipment				
No.	Equipment	Brand Name	Model Name	FCC ID
1	Notebook	DELL	E4300	DoC
2	Fixture	Advantech	WISE-ED20	N/A

2.6 Test Setup Diagram

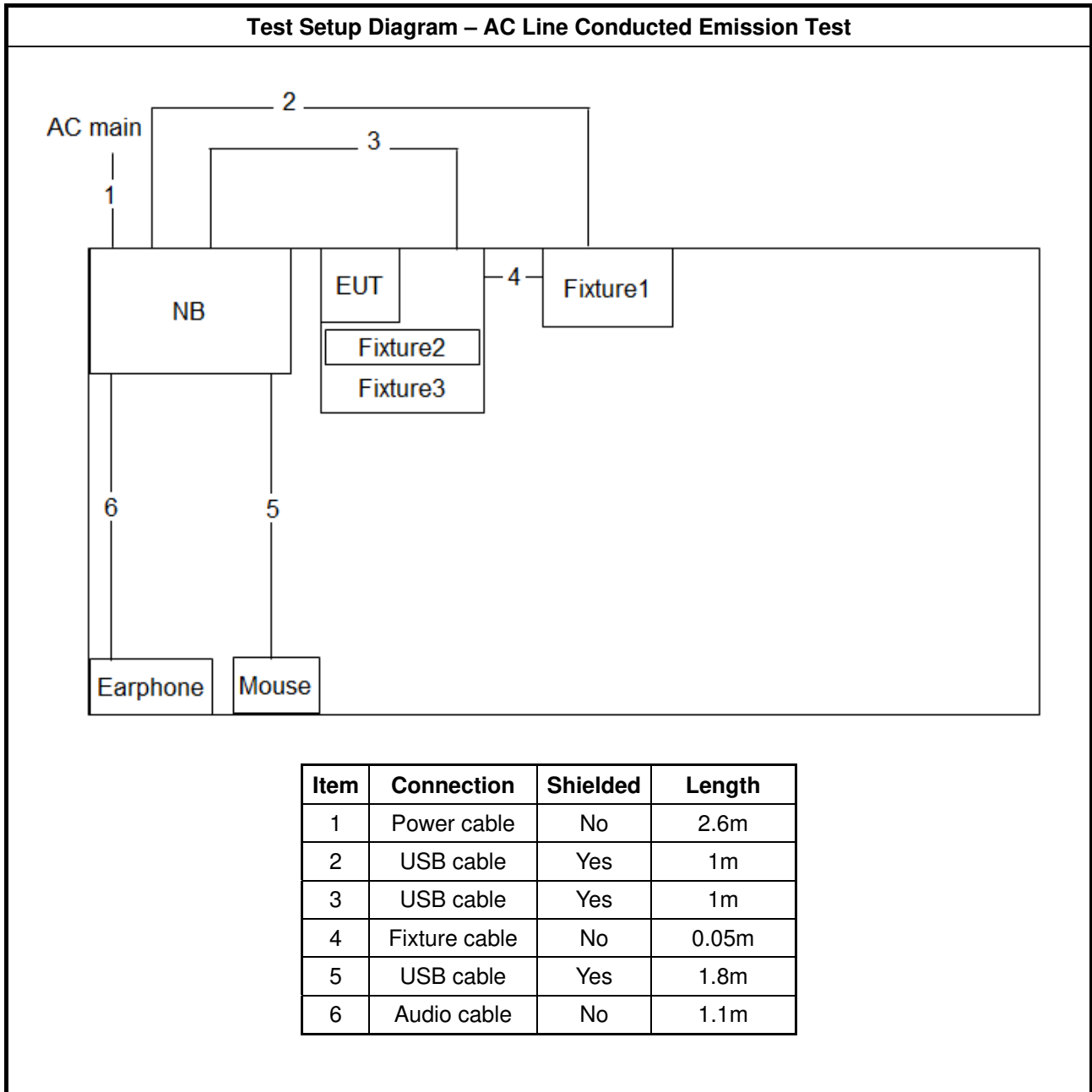

Test Setup Diagram - Radiated Test < 1GHz

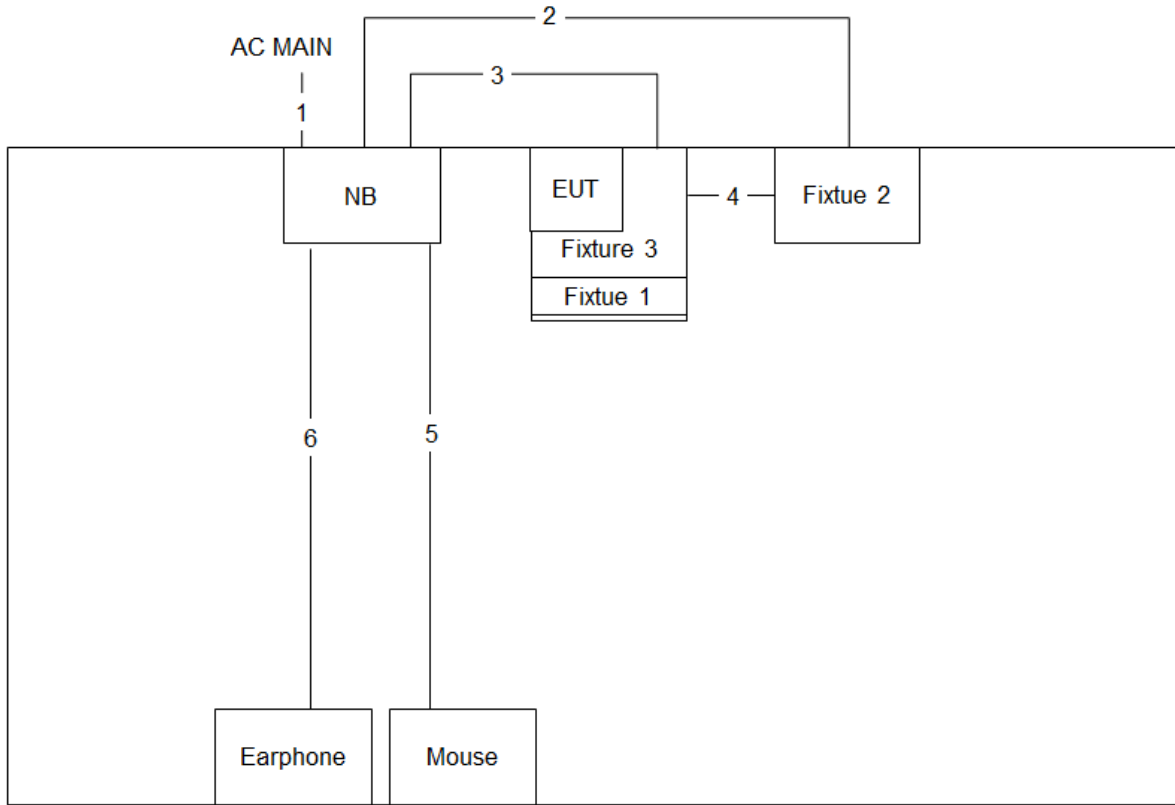

Item	Connection	Shielded	Length
1	Power cable	No	2.6m
2	USB cable	Yes	1m
3	USB cable	Yes	1m
4	Fixture cable	No	0.05m
5	USB cable	Yes	1.8m
6	Audio cable	No	1.1m

Test Setup Diagram - Radiated Test > 1GHz

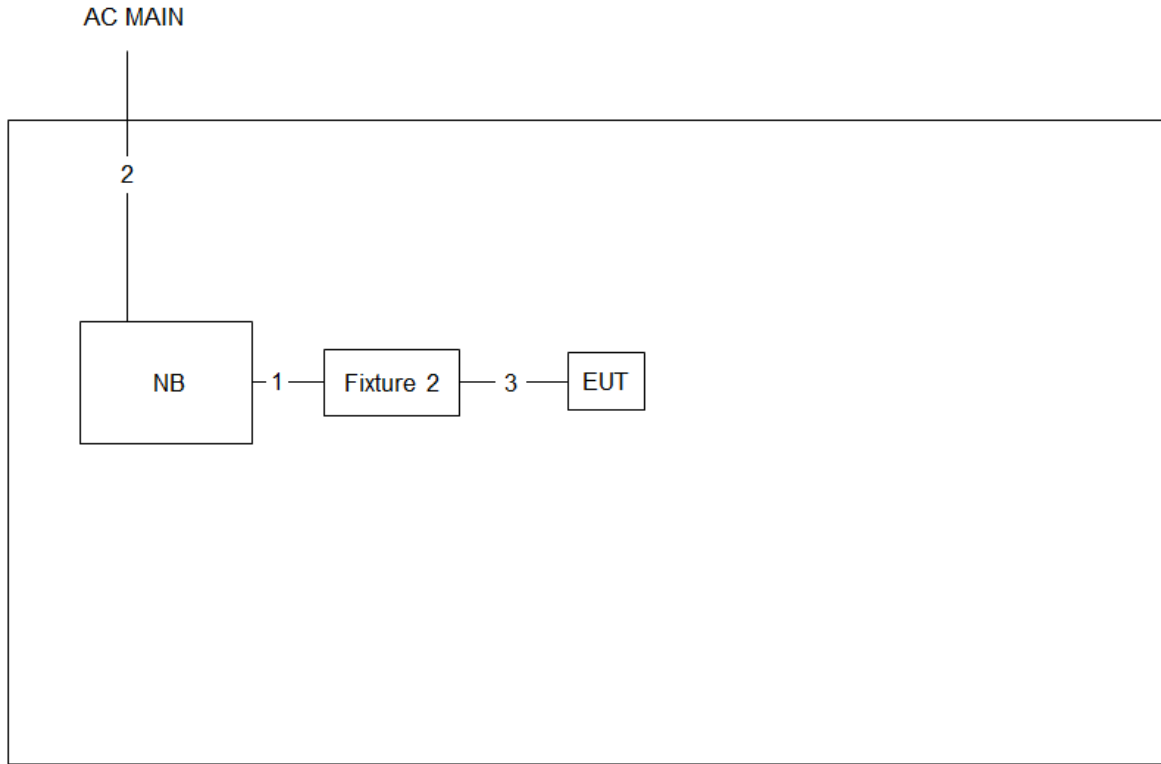

Item	Connection	Shielded	Length
1	USB cable	Yes	1m
2	Power cable	No	2.6m
3	Fixture cable	No	0.05m

3 Test Result

3.1 AC Power-line Conducted Emissions

3.1.1 AC Power-line Conducted Emissions Limit

AC Power-line Conducted Emissions Limit		
Frequency Emission (MHz)	Quasi-Peak	Average
0.15-0.5	66 - 56 *	56 - 46 *
0.5-5	56	46
5-30	60	50

Note 1: * Decreases with the logarithm of the frequency.

3.1.2 Measuring Instruments

Refer a test equipment and calibration data table in this test report.

3.1.3 Test Procedures

Test Method
<ul style="list-style-type: none"> Refer as ANSI C63.10-2013, clause 6.2 foray power-line conducted emissions.

3.1.4 Test Setup

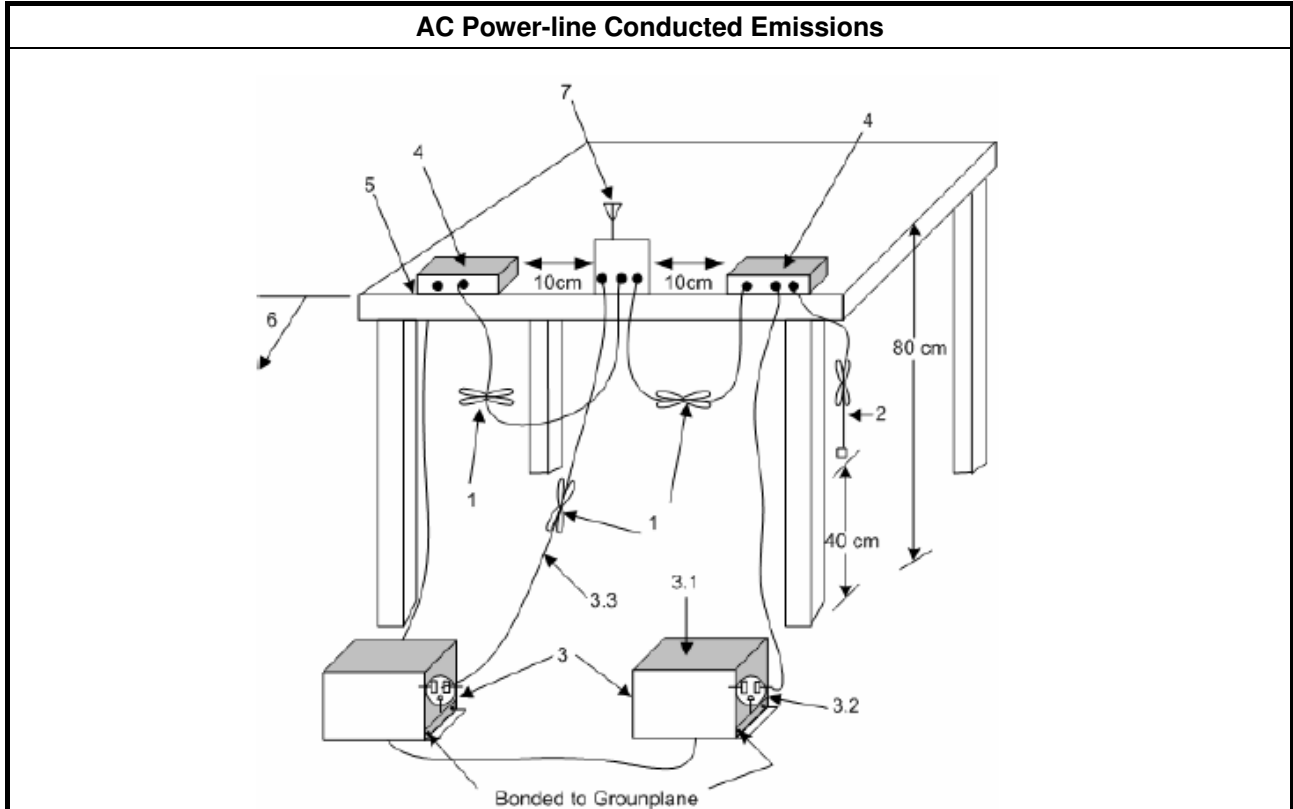



3.1.5 Test Result of AC Power-line Conducted Emissions

Refer as Appendix A

4 Transmitter Test Result – DTS

4.1 DTS Bandwidth

4.1.1 6dB Bandwidth Limit

6dB Bandwidth Limit
Systems using digital modulation techniques:
<ul style="list-style-type: none"> ▪ 6 dB bandwidth \geq 500 kHz.

4.1.2 Measuring Instruments

Refer a test equipment and calibration data table in this test report.

4.1.3 Test Procedures

Test Method
<ul style="list-style-type: none"> ▪ For the emission bandwidth shall be measured using one of the options below:
<input checked="" type="checkbox"/> Refer as FCC KDB 558074, clause 8.1 Option 1 for 6 dB bandwidth measurement.
<input type="checkbox"/> Refer as FCC KDB 558074, clause 8.2 Option 2 for 6 dB bandwidth measurement.
<input type="checkbox"/> Refer as ANSI C63.10, clause 6.9.1 for occupied bandwidth testing.

4.1.4 Test Setup

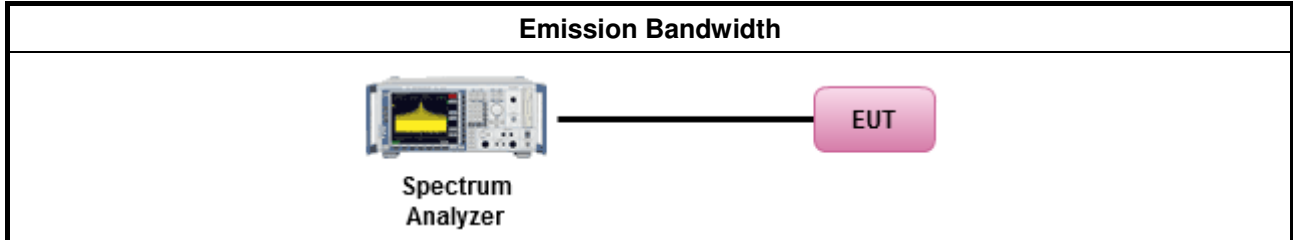

4.1.5 Test Result of Emission Bandwidth

Refer as Appendix B

4.2 Maximum Conducted Output Power

4.2.1 Maximum Conducted Output Power Limit

Maximum Conducted Output Power Limit	
	▪ If $G_{TX} \leq 6$ dBi, then $P_{Out} \leq 30$ dBm (1 W)
	▪ Point-to-multipoint systems (P2M): If $G_{TX} > 6$ dBi, then $P_{Out} = 30 - (G_{TX} - 6)$ dBm
	▪ Point-to-point systems (P2P): If $G_{TX} > 6$ dBi, then $P_{Out} = 30 - (G_{TX} - 6)/3$ dBm
	▪ Smart antenna system (SAS):
	- Single beam: If $G_{TX} > 6$ dBi, then $P_{Out} = 30 - (G_{TX} - 6)/3$ dBm
	- Overlap beam: If $G_{TX} > 6$ dBi, then $P_{Out} = 30 - (G_{TX} - 6)/3$ dBm
	- Aggregate power on all beams: If $G_{TX} > 6$ dBi, then $P_{Out} = 30 - (G_{TX} - 6)/3 + 8$ dB dBm
P_{Out} = maximum peak conducted output power or maximum conducted output power in dBm, G_{TX} = the maximum transmitting antenna directional gain in dBi.	

4.2.2 Measuring Instruments

Refer a test equipment and calibration data table in this test report.

4.2.3 Test Procedures

Test Method	
<ul style="list-style-type: none"> Maximum Peak Conducted Output Power 	
<input type="checkbox"/>	Refer as FCC KDB 558074, clause 9.1.1 Option 1 (RBW ≥ EBW method).
<input type="checkbox"/>	Refer as FCC KDB 558074, clause 9.1.2 Option 2 (peak power meter for VBW ≥ DTS BW)
<ul style="list-style-type: none"> Maximum Conducted Output Power 	
[duty cycle ≥ 98% or external video / power trigger]	
<input type="checkbox"/>	Refer as FCC KDB 558074, clause 9.2.2.2 Method AVGSA-1 (spectral trace averaging).
<input type="checkbox"/>	Refer as FCC KDB 558074, clause 9.2.2.3 Method AVGSA-1 Alt. (slow sweep speed)
duty cycle < 98% and average over on/off periods with duty factor	
<input type="checkbox"/>	Refer as FCC KDB 558074, clause 9.2.2.4 Method AVGSA-2 (spectral trace averaging).
<input type="checkbox"/>	Refer as FCC KDB 558074, clause 9.2.2.5 Method AVGSA-2 Alt. (slow sweep speed)
RF power meter and average over on/off periods with duty factor or gated trigger	
<input checked="" type="checkbox"/>	Refer as FCC KDB 558074, clause 9.2.3 Method AVGPM-G (using an RF average power meter).
<ul style="list-style-type: none"> For conducted measurement. 	
<ul style="list-style-type: none"> If the EUT supports multiple transmit chains using options given below: Refer as FCC KDB 662911, In-band power measurements. Using the measure-and-sum approach, measured all transmit ports individually. Sum the power (in linear power units e.g., mW) of all ports for each individual sample and save them. 	
<ul style="list-style-type: none"> If multiple transmit chains, EIRP calculation could be following as methods: $P_{total} = P_1 + P_2 + \dots + P_n$ (calculated in linear unit [mW] and transfer to log unit [dBm]) $EIRP_{total} = P_{total} + DG$ 	

4.2.4 Test Setup

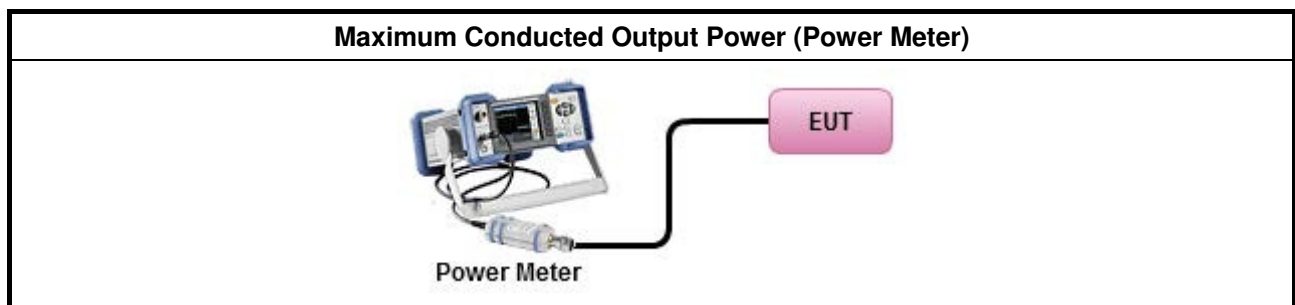

4.2.5 Test Result of Maximum Conducted Output Power

Refer as Appendix C

4.3 Power Spectral Density

4.3.1 Power Spectral Density Limit

Power Spectral Density Limit
<ul style="list-style-type: none"> ▪ Power Spectral Density (PSD) ≤ 8 dBm/3kHz

4.3.2 Measuring Instruments

Refer a test equipment and calibration data table in this test report.

4.3.3 Test Procedures

Test Method
<ul style="list-style-type: none"> ▪ Peak power spectral density procedures that the same method as used to determine the conducted output power. If maximum peak conducted output power was measured to demonstrate compliance to the output power limit, then the peak PSD procedure below (Method PKPSD) shall be used. If maximum conducted output power was measured to demonstrate compliance to the output power limit, then one of the average PSD procedures shall be used, as applicable based on the following criteria (the peak PSD procedure is also an acceptable option).
<input checked="" type="checkbox"/> Refer as FCC KDB 558074, clause 10.2 Method PKPSD (RBW=3-100kHz; Detector=peak). [duty cycle ≥ 98% or external video / power trigger]
<input type="checkbox"/> Refer as FCC KDB 558074, clause 10.3 Method AVGPSD-1 (spectral trace averaging).
<input type="checkbox"/> Refer as FCC KDB 558074, clause 10.4 Method AVGPSD-2 (slow sweep speed) duty cycle < 98% and average over on/off periods with duty factor
<input type="checkbox"/> Refer as FCC KDB 558074, clause 10.5 Method AVGPSD-1 Alt (spectral trace averaging).
<input type="checkbox"/> Refer as FCC KDB 558074, clause 10.6 Method AVGPSD-2 Alt. (slow sweep speed)
<ul style="list-style-type: none"> ▪ For conducted measurement.
<ul style="list-style-type: none"> ▪ If The EUT supports multiple transmit chains using options given below: <ul style="list-style-type: none"> <input checked="" type="checkbox"/> Option 1: Measure and sum the spectra across the outputs. Refer as FCC KDB 662911, In-band power spectral density (PSD). Sample all transmit ports simultaneously using a spectrum analyzer for each transmit port. Where the trace bin-by-bin of each transmit port summing can be performed. (i.e., in the first spectral bin of output 1 is summed with that in the first spectral bin of output 2 and that from the first spectral bin of output 3, and so on up to the NTX output to obtain the value for the first frequency bin of the summed spectrum.). Add up the amplitude (power) values for the different transmit chains and use this as the new data trace. <input type="checkbox"/> Option 2: Measure and sum spectral maxima across the outputs. With this technique, spectra are measured at each output of the device at the required resolution bandwidth. The maximum value (peak) of each spectrum is determined. These maximum values are then summed mathematically in linear power units across the outputs. These operations shall be performed separately over frequency spans that have different out-of-band or spurious emission limits, <input type="checkbox"/> Option 3: Measure and add 10 log(N) dB, where N is the number of transmit chains. Refer as FCC KDB 662911, In-band power spectral density (PSD). Performed at each transmit chains and each transmit chains shall be compared with the limit have been reduced with 10 log(N). Or each transmit chains shall be add 10 log(N) to compared with the limit.

4.3.4 Test Setup

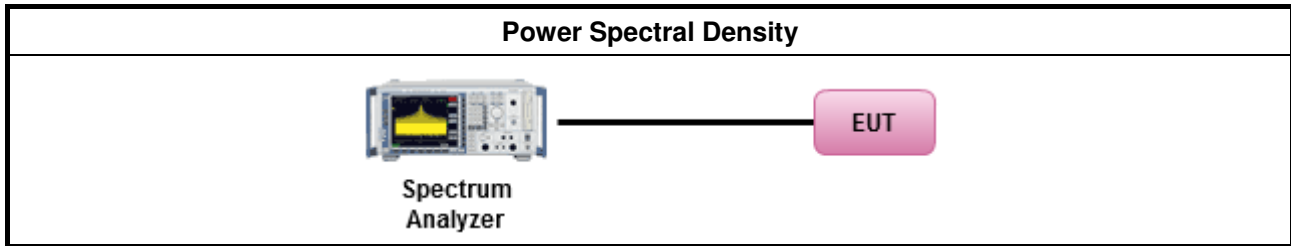

4.3.5 Test Result of Power Spectral Density

Refer as Appendix D

4.4 Emissions in Non-restricted Frequency Bands

4.4.1 Emissions in Non-restricted Frequency Bands Limit

Un-restricted Band Emissions Limit	
RF output power procedure	Limit (dB)
Peak output power procedure	20
Average output power procedure	30

Note 1: If the peak output power procedure is used to measure the fundamental emission power to demonstrate compliance to requirements, then the peak conducted output power measured within any 100 kHz outside the authorized frequency band shall be attenuated by at least 20 dB relative to the maximum measured in-band peak PSD level.

Note 2: If the average output power procedure is used to measure the fundamental emission power to demonstrate compliance to requirements, then the power in any 100 kHz outside of the authorized frequency band shall be attenuated by at least 30 dB relative to the maximum measured in-band average PSD level.

4.4.2 Measuring Instruments

Refer a test equipment and calibration data table in this test report.

4.4.3 Test Procedures

Test Method
<ul style="list-style-type: none"> Refer as FCC KDB 558074, clause 11 for unwanted emissions into non-restricted bands.

4.4.4 Test Setup

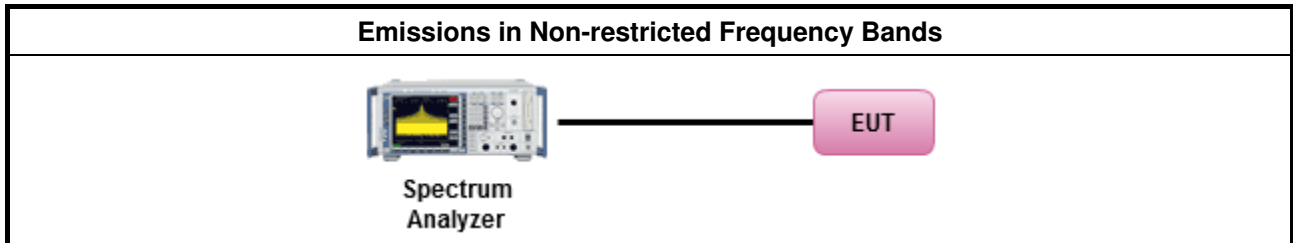

4.4.5 Test Result of Emissions in Non-restricted Frequency Bands

Refer as Appendix E

4.5 Emissions in Restricted Frequency Bands

4.5.1 Emissions in Restricted Frequency Bands Limit

Restricted Band Emissions Limit			
Frequency Range (MHz)	Field Strength (uV/m)	Field Strength (dBuV/m)	Measure Distance (m)
0.009~0.490	2400/F(kHz)	48.5 - 13.8	300
0.490~1.705	24000/F(kHz)	33.8 - 23	30
1.705~30.0	30	29	30
30~88	100	40	3
88~216	150	43.5	3
216~960	200	46	3
Above 960	500	54	3

Note 1: Test distance for frequencies at or above 30 MHz, measurements may be performed at a distance other than the limit distance provided they are not performed in the near field and the emissions to be measured can be detected by the measurement equipment. When performing measurements at a distance other than that specified, the results shall be extrapolated to the specified distance using an extrapolation factor of 20 dB/decade (inverse of linear distance for field-strength measurements, inverse of linear distance-squared for power-density measurements).

Note 2: Test distance for frequencies at below 30 MHz, measurements may be performed at a distance closer than the EUT limit distance; however, an attempt should be made to avoid making measurements in the near field. When performing measurements below 30 MHz at a closer distance than the limit distance, the results shall be extrapolated to the specified distance by either making measurements at a minimum of two or more distances on at least one radial to determine the proper extrapolation factor or by using the square of an inverse linear distance extrapolation factor (40 dB / decade). The test report shall specify the extrapolation method used to determine compliance of the EUT.

4.5.2 Measuring Instruments

Refer a test equipment and calibration data table in this test report.

4.5.3 Test Procedures

Test Method	
<ul style="list-style-type: none"> ▪ The average emission levels shall be measured in [duty cycle ≥ 98 or duty factor]. 	
<ul style="list-style-type: none"> ▪ Refer as ANSI C63.10, clause 6.9.2.2 band-edge testing shall be performed at the lowest frequency channel and highest frequency channel within the allowed operating band. 	
<ul style="list-style-type: none"> ▪ For the transmitter unwanted emissions shall be measured using following options below: 	
	<ul style="list-style-type: none"> ▪ Refer as FCC KDB 558074, clause 12 for unwanted emissions into restricted bands.
	<input type="checkbox"/> Refer as FCC KDB 558074, clause 12.2.5.1 Option 1 (trace averaging for duty cycle $\geq 98\%$)
	<input type="checkbox"/> Refer as FCC KDB 558074, clause 12.2.5.2 Option 2 (trace averaging + duty factor).
	<input checked="" type="checkbox"/> Refer as FCC KDB 558074, clause 12.2.5.3 Option 3 (Reduced VBW $\geq 1/T$).
	<input type="checkbox"/> Refer as ANSI C63.10, clause 4.2.3.2.3 (Reduced VBW). VBW $\geq 1/T$, where T is pulse time.
	<input type="checkbox"/> Refer as ANSI C63.10, clause 4.2.3.2.4 average value of pulsed emissions.
	<input checked="" type="checkbox"/> Refer as FCC KDB 558074, clause 12.2.4 measurement procedure peak limit.
<ul style="list-style-type: none"> ▪ For the transmitter band-edge emissions shall be measured using following options below: 	
	<ul style="list-style-type: none"> ▪ Refer as FCC KDB 558074 clause 13.1, When the performing peak or average radiated measurements, emissions within 2 MHz of the authorized band edge may be measured using the marker-delta method described below.
	<ul style="list-style-type: none"> ▪ Refer as FCC KDB 558074, clause 13.2 (ANSI C63.10, clause 6.9.3) for marker-delta method for band-edge measurements.
	<ul style="list-style-type: none"> ▪ Refer as FCC KDB 558074, clause 13.3 for narrower resolution bandwidth (100kHz) using the band power and summing the spectral levels (i.e., 1 MHz).
<ul style="list-style-type: none"> ▪ For conducted and cabinet radiation measurement, refer as FCC KDB 558074, clause 12.2.2. 	
	<ul style="list-style-type: none"> ▪ For conducted unwanted emissions into restricted bands (absolute emission limits). Devices with multiple transmit chains using options given below: (1) Measure and sum the spectra across the outputs or (2) Measure and add 10 log(N) dB
	<ul style="list-style-type: none"> ▪ For FCC KDB 662911 The methodology described here may overestimate array gain, thereby resulting in apparent failures to satisfy the out-of-band limits even if the device is actually compliant. In such cases, compliance may be demonstrated by performing radiated tests around the frequencies at which the apparent failures occurred.

4.5.4 Test Setup

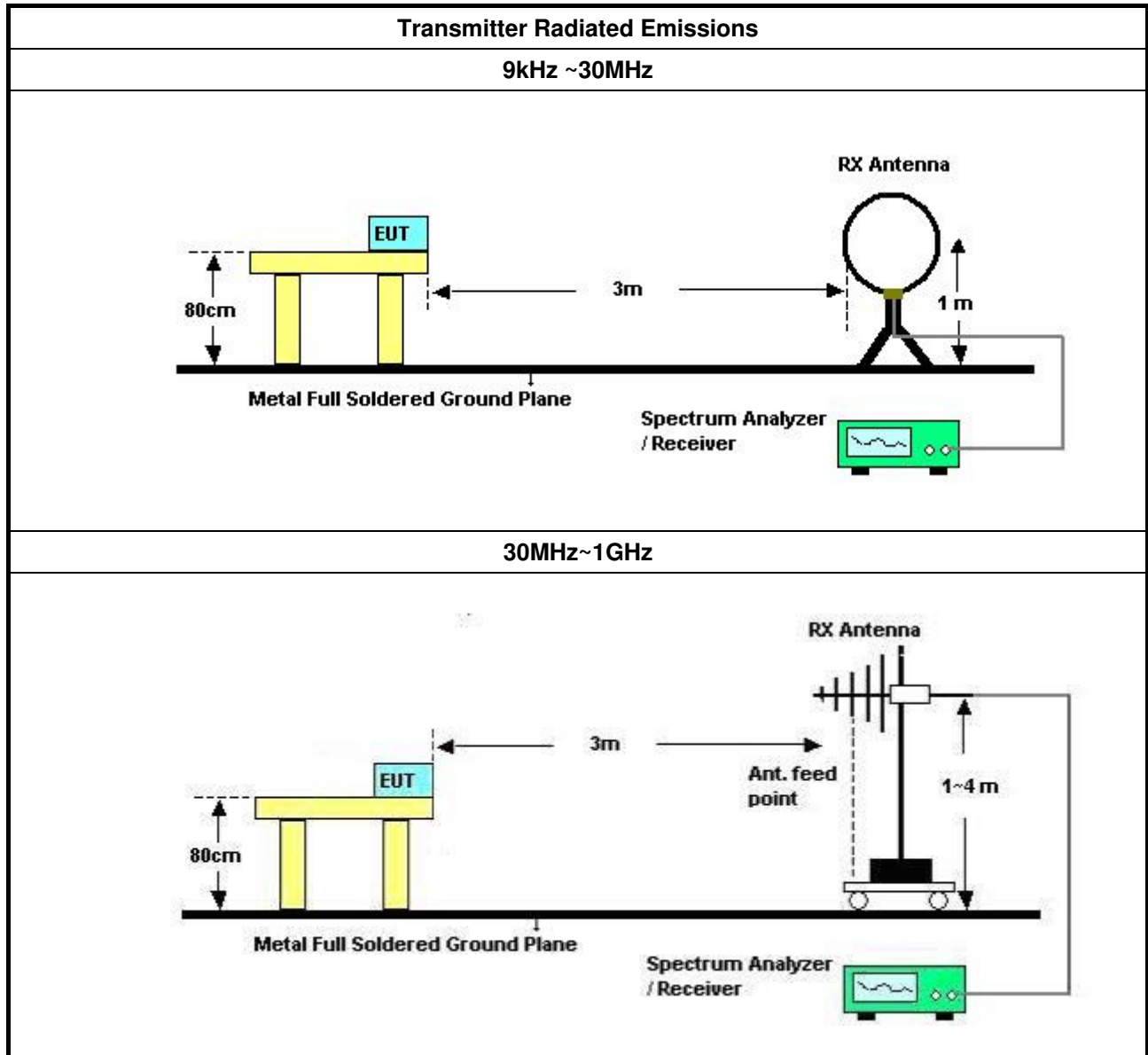

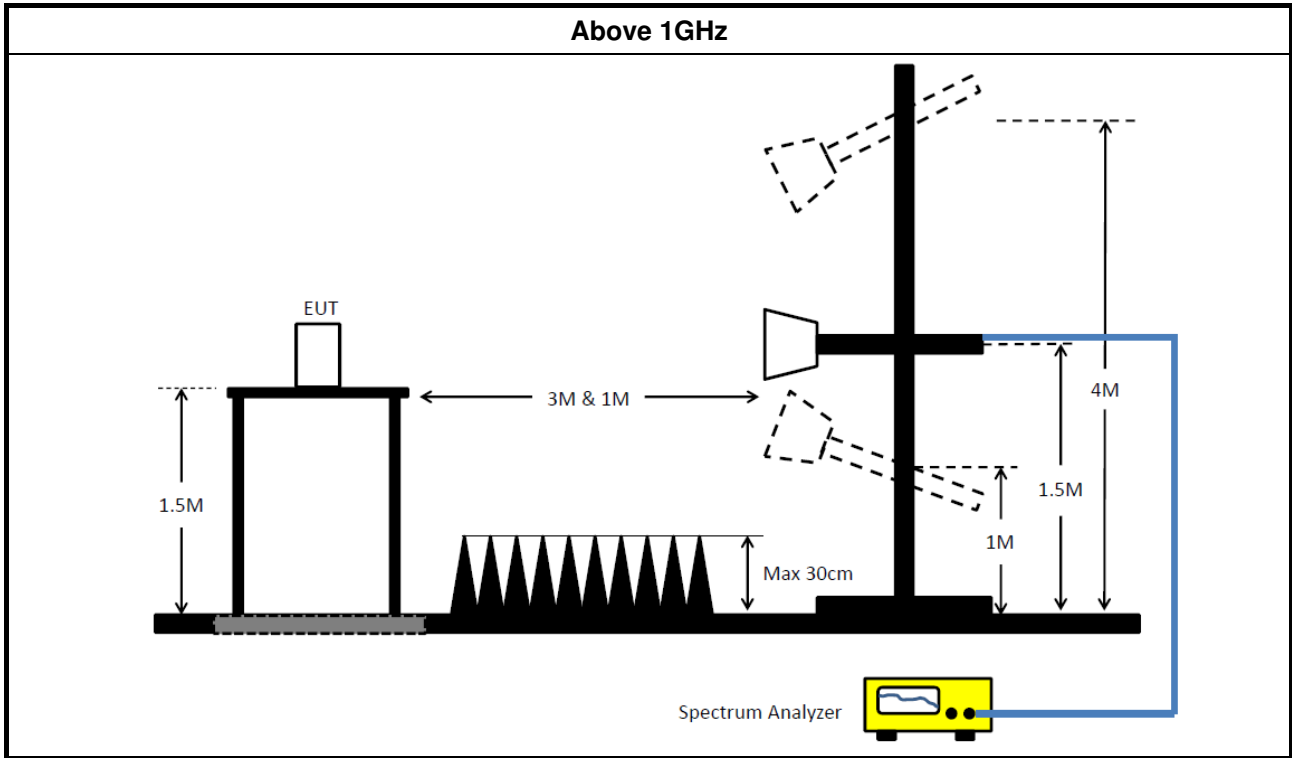

4.5.5 Transmitter Radiated Unwanted Emissions (Below 30MHz)

All amplitude of spurious emissions that are attenuated by more than 20 dB below the permissible value has no need to be reported.

4.5.6 Transmitter Radiated Unwanted Emissions

Refer as Appendix F

5 Transmitter Test Result – Hybrid

5.1 20dB Bandwidth and Carrier Frequency Separation

5.1.1 20dB Bandwidth and Carrier Frequency Separation Limit

20dB Bandwidth and Carrier Frequency Separation Limit for Frequency Hopping Systems	
<ul style="list-style-type: none"> 902-928 MHz Band: 	
	<ul style="list-style-type: none"> $N \geq 50$ and $ChS \geq \text{MAX}$ (20 dB bandwidth, 25 kHz); 20 dB bandwidth \leq 250 kHz.
	<ul style="list-style-type: none"> $50 > N \geq 25$ and $ChS \geq \text{MAX}$ (20 dB bandwidth, 25 kHz); 20 dB bandwidth $>$ 250 kHz.
<ul style="list-style-type: none"> 2400-2483.5 MHz Band: 	
	<ul style="list-style-type: none"> $N \geq 75$ and $ChS \geq \text{MAX}$ (20 dB bandwidth, 25 kHz).
	<ul style="list-style-type: none"> $75 > N \geq 15$ and $ChS \geq \text{MAX}$ (20 dB bandwidth 2/3, 25 kHz).
<ul style="list-style-type: none"> 5725-5850 MHz Band: 	
	<ul style="list-style-type: none"> $N \geq 75$ and $ChS \geq \text{MAX}$ (20 dB bandwidth, 25 kHz); 20 dB bandwidth \leq 1 MHz.
N: Number of Hopping Frequencies; ChS: Hopping Channel Separation	

5.1.2 Measuring Instruments

Refer a test equipment and calibration data table in this test report.

5.1.3 Test Procedures

Test Method
<ul style="list-style-type: none"> Refer as ANSI C63.10-2013, clause 6.9.1 for 20 dB bandwidth measurement.
<ul style="list-style-type: none"> Refer as ANSI C63.10-2013, clause 7.8.2 for carrier frequency separation measurement.

5.1.4 Test Setup

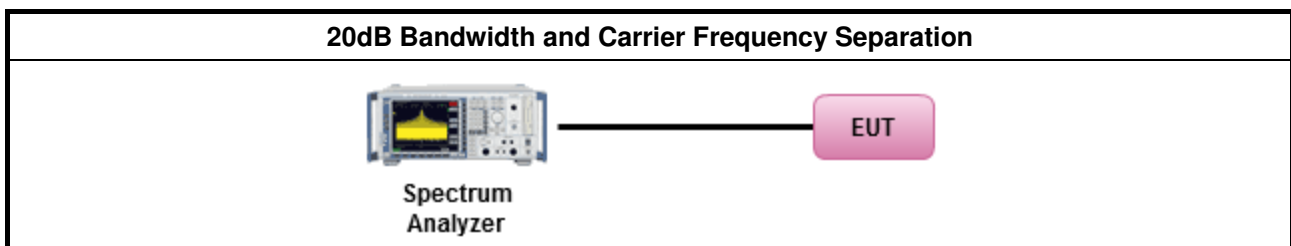

5.1.5 Test Result of 20dB Bandwidth

Refer as Appendix G

5.1.6 Test Result of Carrier Frequency Separation

Refer as Appendix G

5.2 Maximum Conducted Output Power

5.2.1 Maximum Conducted Output Power Limit

Maximum Conducted Output Power Limit	
	<ul style="list-style-type: none"> ▪ If $G_{TX} \leq 6$ dBi, then $P_{Out} \leq 30$ dBm (1 W)
	<ul style="list-style-type: none"> ▪ Point-to-multipoint systems (P2M): If $G_{TX} > 6$ dBi, then $P_{Out} = 30 - (G_{TX} - 6)$ dBm
	<ul style="list-style-type: none"> ▪ Point-to-point systems (P2P): If $G_{TX} > 6$ dBi, then $P_{Out} = 30 - (G_{TX} - 6)/3$ dBm
	<ul style="list-style-type: none"> ▪ Smart antenna system (SAS):
	<ul style="list-style-type: none"> - Single beam: If $G_{TX} > 6$ dBi, then $P_{Out} = 30 - (G_{TX} - 6)/3$ dBm
	<ul style="list-style-type: none"> - Overlap beam: If $G_{TX} > 6$ dBi, then $P_{Out} = 30 - (G_{TX} - 6)/3$ dBm
	<ul style="list-style-type: none"> - Aggregate power on all beams: If $G_{TX} > 6$ dBi, then $P_{Out} = 30 - (G_{TX} - 6)/3 + 8$ dB dBm
<p>P_{Out} = maximum peak conducted output power or maximum conducted output power in dBm, G_{TX} = the maximum transmitting antenna directional gain in dBi.</p>	

5.2.2 Measuring Instruments

Refer a test equipment and calibration data table in this test report.

5.2.3 Test Procedures

Test Method	
<ul style="list-style-type: none"> ▪ Maximum Peak Conducted Output Power 	
<input type="checkbox"/>	Refer as FCC KDB 558074, clause 9.1.1 Option 1 (RBW ≥ EBW method).
<input type="checkbox"/>	Refer as FCC KDB 558074, clause 9.1.2 Option 2 (peak power meter for VBW ≥ DTS BW)
<ul style="list-style-type: none"> ▪ Maximum Conducted Output Power 	
[duty cycle ≥ 98% or external video / power trigger]	
<input type="checkbox"/>	Refer as FCC KDB 558074, clause 9.2.2.2 Method AVGSA-1 (spectral trace averaging).
<input type="checkbox"/>	Refer as FCC KDB 558074, clause 9.2.2.3 Method AVGSA-1 Alt. (slow sweep speed)
duty cycle < 98% and average over on/off periods with duty factor	
<input type="checkbox"/>	Refer as FCC KDB 558074, clause 9.2.2.4 Method AVGSA-2 (spectral trace averaging).
<input type="checkbox"/>	Refer as FCC KDB 558074, clause 9.2.2.5 Method AVGSA-2 Alt. (slow sweep speed)
RF power meter and average over on/off periods with duty factor or gated trigger	
<input checked="" type="checkbox"/>	Refer as FCC KDB 558074, clause 9.2.3 Method AVGPM-G (using an RF average power meter).
<ul style="list-style-type: none"> ▪ For conducted measurement. 	
<ul style="list-style-type: none"> ▪ If the EUT supports multiple transmit chains using options given below: Refer as FCC KDB 662911, In-band power measurements. Using the measure-and-sum approach, measured all transmit ports individually. Sum the power (in linear power units e.g., mW) of all ports for each individual sample and save them. 	
<ul style="list-style-type: none"> ▪ If multiple transmit chains, EIRP calculation could be following as methods: $P_{total} = P_1 + P_2 + \dots + P_n$ (calculated in linear unit [mW] and transfer to log unit [dBm]) $EIRP_{total} = P_{total} + DG$ 	

5.2.4 Test Setup

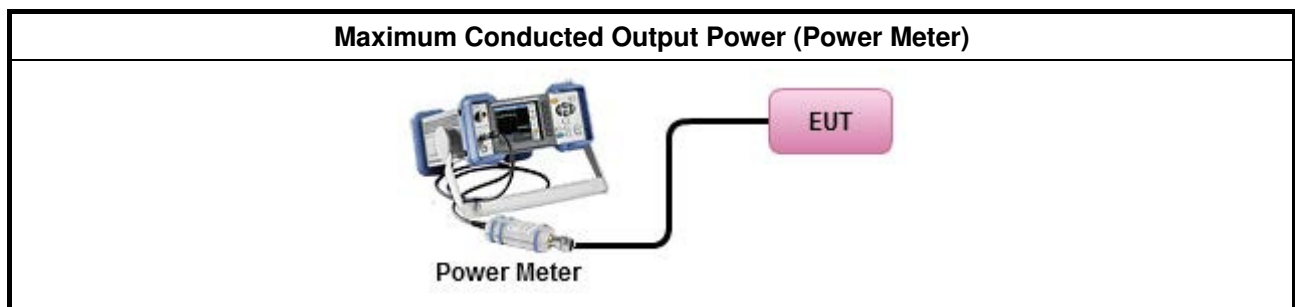

5.2.5 Test Result of Maximum Conducted Output Power

Refer as Appendix H

5.3 Power Spectral Density

5.3.1 Power Spectral Density Limit

Power Spectral Density Limit
<ul style="list-style-type: none"> ▪ Power Spectral Density (PSD) ≤ 8 dBm/3kHz

5.3.2 Measuring Instruments

Refer a test equipment and calibration data table in this test report.

5.3.3 Test Procedures

Test Method
<ul style="list-style-type: none"> ▪ Peak power spectral density procedures that the same method as used to determine the conducted output power. If maximum peak conducted output power was measured to demonstrate compliance to the output power limit, then the peak PSD procedure below (Method PKPSD) shall be used. If maximum conducted output power was measured to demonstrate compliance to the output power limit, then one of the average PSD procedures shall be used, as applicable based on the following criteria (the peak PSD procedure is also an acceptable option).
<input checked="" type="checkbox"/> Refer as FCC KDB 558074, clause 10.2 Method PKPSD (RBW=3-100kHz; Detector=peak). [duty cycle ≥ 98% or external video / power trigger]
<input type="checkbox"/> Refer as FCC KDB 558074, clause 10.3 Method AVGPSD-1 (spectral trace averaging).
<input type="checkbox"/> Refer as FCC KDB 558074, clause 10.4 Method AVGPSD-2 (slow sweep speed) duty cycle < 98% and average over on/off periods with duty factor
<input type="checkbox"/> Refer as FCC KDB 558074, clause 10.5 Method AVGPSD-1 Alt (spectral trace averaging).
<input type="checkbox"/> Refer as FCC KDB 558074, clause 10.6 Method AVGPSD-2 Alt. (slow sweep speed)
<ul style="list-style-type: none"> ▪ For conducted measurement.
<ul style="list-style-type: none"> ▪ If The EUT supports multiple transmit chains using options given below: <ul style="list-style-type: none"> <input checked="" type="checkbox"/> Option 1: Measure and sum the spectra across the outputs. Refer as FCC KDB 662911, In-band power spectral density (PSD). Sample all transmit ports simultaneously using a spectrum analyzer for each transmit port. Where the trace bin-by-bin of each transmit port summing can be performed. (i.e., in the first spectral bin of output 1 is summed with that in the first spectral bin of output 2 and that from the first spectral bin of output 3, and so on up to the NTX output to obtain the value for the first frequency bin of the summed spectrum.). Add up the amplitude (power) values for the different transmit chains and use this as the new data trace. <input type="checkbox"/> Option 2: Measure and sum spectral maxima across the outputs. With this technique, spectra are measured at each output of the device at the required resolution bandwidth. The maximum value (peak) of each spectrum is determined. These maximum values are then summed mathematically in linear power units across the outputs. These operations shall be performed separately over frequency spans that have different out-of-band or spurious emission limits, <input type="checkbox"/> Option 3: Measure and add 10 log(N) dB, where N is the number of transmit chains. Refer as FCC KDB 662911, In-band power spectral density (PSD). Performed at each transmit chains and each transmit chains shall be compared with the limit have been reduced with 10 log(N). Or each transmit chains shall be add 10 log(N) to compared with the limit.

5.3.4 Test Setup

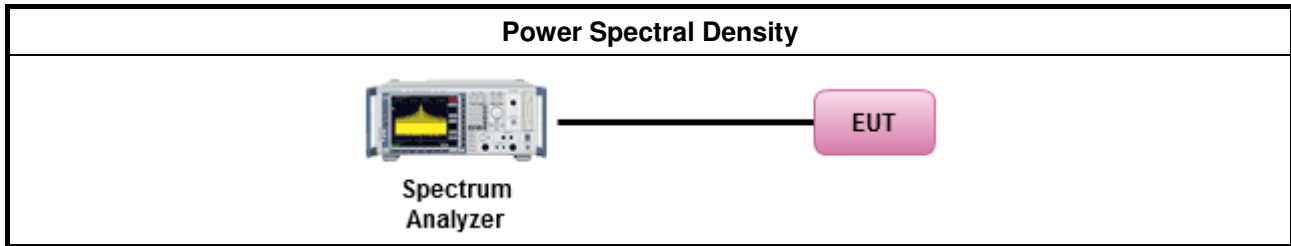

5.3.5 Test Result of Power Spectral Density

Refer as Appendix I

5.4 Number of Hopping Frequencies and Hopping Bandedge

5.4.1 Number of Hopping Frequencies Limit

Number of Hopping Frequencies Limit	
▪ 902-928 MHz Band:	
	▪ ChS \geq MAX (20 dB bandwidth, 25 kHz); 20 dB bandwidth \leq 250 kHz.
	▪ ChS \geq MAX (20 dB bandwidth, 25 kHz); 20 dB bandwidth $>$ 250 kHz.
▪ 2400-2483.5 MHz Band:	
	▪ ChS \geq MAX (20 dB bandwidth, 25 kHz).
	▪ ChS \geq MAX (20 dB bandwidth 2/3, 25 kHz).
▪ 5725-5850 MHz Band:	
	▪ ChS \geq MAX (20 dB bandwidth, 25 kHz); 20 dB bandwidth \leq 1 MHz.
ChS : Hopping Channel Separation	

5.4.2 Hopping Bandedge Limit

Refer clause 5.6.1 and clause 5.7.1

5.4.3 Measuring Instruments

Refer a test equipment and calibration data table in this test report.

5.4.4 Test Procedures

Test Method
▪ Refer as ANSI C63.10-2013, clause 7.8.3 for number of hopping frequencies measurement.
▪ Refer as ANSI C63.10-2013, clause 7.8.6 for hopping frequencies Bandedge measurement.

5.4.5 Test Setup

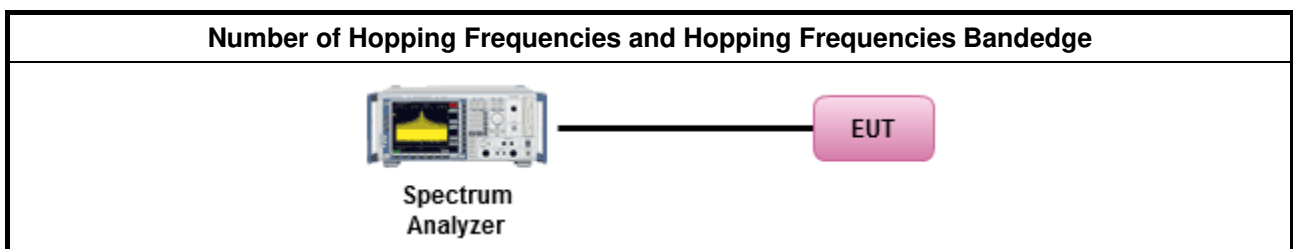

5.4.6 Test Result of Number of Hopping Frequencies

Refer as Appendix J

5.4.7 Test Result of Number of Hopping Frequencies Bandedge

Refer as Appendix J

5.5 Time of Occupancy (Dwell Time)

5.5.1 Time of Occupancy (Dwell Time) Limit

20dB Bandwidth and Carrier Frequency Separation Limit for Frequency Hopping Systems	
▪ 902-928 MHz Band:	▪ 0.4s in N x 0.4 period
▪ 2400-2483.5 MHz Band:	▪ 0.4s in N x 0.4 period
▪ 5725-5850 MHz Band:	▪ 0.4s in N x 0.4 period
N: Number of Hopping Frequencies	

5.5.2 Measuring Instruments

Refer a test equipment and calibration data table in this test report.

5.5.3 Test Procedures

Test Method	
▪ Refer as ANSI C63.10-2013, clause 7.8.4 for dwell time measurement.	
▪ Bluetooth ACL packets can be 1, 3, or 5 time slots. Following as dwell time. Operate DH5 at maximum dwell time and maximum duty cycle.	
▪ The DH5 packet can cover up to 5 time slots. Operate DH5 at maximum dwell time and maximum duty cycle. A maximum length packet has duration of 5 time slots. The hopping rate is 1600 hops/second so the maximum dwell time is 5/1600 seconds, or 3.125ms. DH5 Packet permit maximum $1600 / 79 / 6 = 3.37$ hops per second in each channel.	

5.5.4 Test Setup

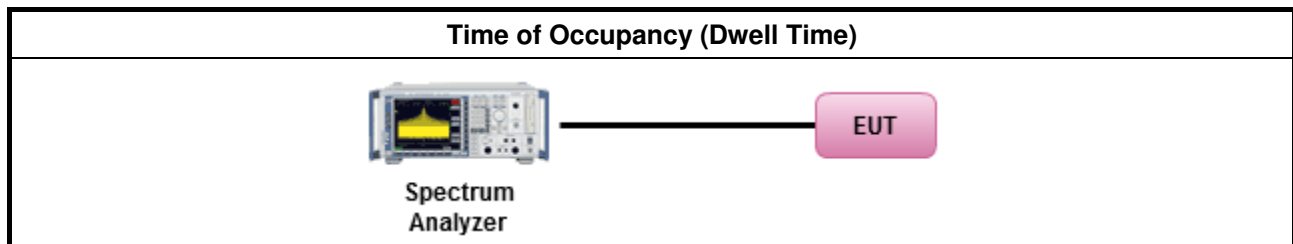

5.5.5 Test Result of Time of Occupancy (Dwell Time)

Refer as Appendix K

5.6 Emissions in Non-restricted Frequency Bands

5.6.1 Emissions in Non-restricted Frequency Bands Limit

Un-restricted Band Emissions Limit	
RF output power procedure	Limit (dB)
Peak output power procedure	20
Note 1: If the peak output power procedure is used to measure the fundamental emission power to demonstrate compliance to requirements, then the peak conducted output power measured within any 100 kHz outside the authorized frequency band shall be attenuated by at least 20 dB relative to the maximum measured in-band peak PSD level.	

5.6.2 Measuring Instruments

Refer a test equipment and calibration data table in this test report.

5.6.3 Test Procedures

Test Method
<ul style="list-style-type: none"> Refer as ANSI C63.10-2013, clause 7.8.8 for unwanted emissions into non-restricted bands.

5.6.4 Test Setup

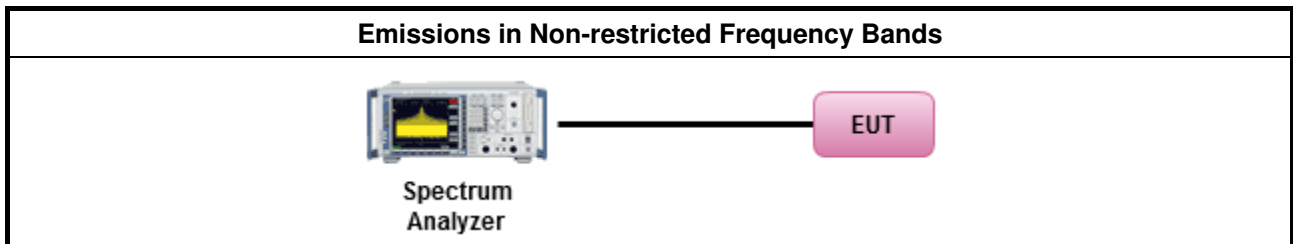

5.6.5 Test Result of Emissions in Non-restricted Frequency Bands

Refer as Appendix L

5.7 Emissions in Restricted Frequency Bands

5.7.1 Emissions in Restricted Frequency Bands Limit

Restricted Band Emissions Limit			
Frequency Range (MHz)	Field Strength (uV/m)	Field Strength (dBuV/m)	Measure Distance (m)
0.009~0.490	2400/F(kHz)	48.5 - 13.8	300
0.490~1.705	24000/F(kHz)	33.8 - 23	30
1.705~30.0	30	29	30
30~88	100	40	3
88~216	150	43.5	3
216~960	200	46	3
Above 960	500	54	3

Note 1: Test distance for frequencies at or above 30 MHz, measurements may be performed at a distance other than the limit distance provided they are not performed in the near field and the emissions to be measured can be detected by the measurement equipment. When performing measurements at a distance other than that specified, the results shall be extrapolated to the specified distance using an extrapolation factor of 20 dB/decade (inverse of linear distance for field-strength measurements, inverse of linear distance-squared for power-density measurements).

Note 2: Test distance for frequencies at below 30 MHz, measurements may be performed at a distance closer than the EUT limit distance; however, an attempt should be made to avoid making measurements in the near field. When performing measurements below 30 MHz at a closer distance than the limit distance, the results shall be extrapolated to the specified distance by either making measurements at a minimum of two or more distances on at least one radial to determine the proper extrapolation factor or by using the square of an inverse linear distance extrapolation factor (40 dB / decade). The test report shall specify the extrapolation method used to determine compliance of the EUT.

5.7.2 Measuring Instruments

Refer a test equipment and calibration data table in this test report.

5.7.3 Test Procedures

Test Method	
	<ul style="list-style-type: none"> ▪ The average emission levels shall be measured in [hopping duty factor].
	<ul style="list-style-type: none"> ▪ Refer as ANSI C63.10; clause 6.9.2.2 band-edge testing shall be performed at the lowest frequency channel and highest frequency channel within the allowed operating band.
	<ul style="list-style-type: none"> ▪ For the transmitter unwanted emissions shall be measured using following options below: <ul style="list-style-type: none"> ▪ Refer as ANSI C63.10, clause 4.1.4.2.1 QP value. ▪ Refer as ANSI C63.10, clause 4.1.4.2.2 measurement procedure peak. ▪ Refer as ANSI C63.10, clause 4.1.4.2.4 average value of hopping pulsed emissions.

5.7.4 Test Setup

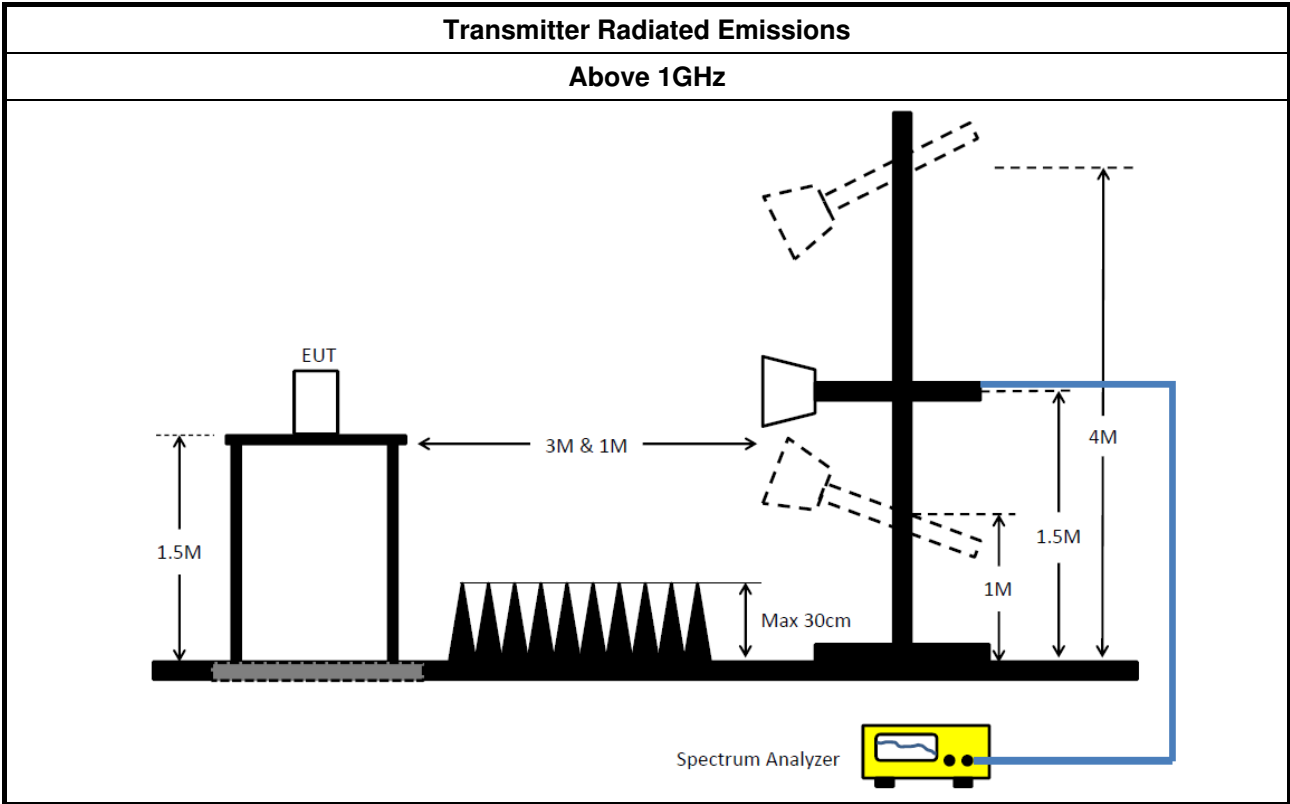

5.7.5 Transmitter Radiated Unwanted Emissions

Refer as Appendix M



6 Test Equipment and Calibration Data

Instrument	Manufacturer	Model No.	Serial No.	Characteristics	Calibration Date	Remark
EMI Receiver	Agilent	N9038A	My52260123	9kHz ~ 8.45GHz	Jan. 23, 2017	Conduction (CO01-CB)
LISN	F.C.C.	FCC-LISN-50-16-2	04083	150kHz ~ 100MHz	Dec. 14, 2016	Conduction (CO01-CB)
LISN	Schwarzbeck	NSLK 8127	8127647	9kHz ~ 30MHz	Dec. 21, 2016	Conduction (CO01-CB)
COND Cable	Woken	Cable	01	150kHz ~ 30MHz	May 24, 2016	Conduction (CO01-CB)
Software	Audix	E3	6.120210n	-	N.C.R.	Conduction (CO01-CB)
BILOG ANTENNA with 6dB Attenuator	TESEQ & EMCI	CBL6112D & N-6-06	37880 & AT-N0609	20MHz ~ 2GHz	Aug. 30, 2016	Radiation (03CH01-CB)
Horn Antenna	EMCO	3115	00075790	750MHz ~ 18GHz	Nov. 10, 2016	Radiation (03CH01-CB)
Horn Antenna	Schwarzbeck	BBHA 9170	BBHA9170252	15GHz ~ 40GHz	Jul. 25, 2016	Radiation (03CH01-CB)
Pre-Amplifier	Agilent	8447D	2944A10991	0.1MHz ~ 1.3GHz	Mar. 15, 2016	Radiation (03CH01-CB)
Pre-Amplifier	Agilent	8447D	2944A10991	0.1MHz ~ 1.3GHz	Mar. 13, 2017	Radiation (03CH01-CB)
Pre-Amplifier	Agilent	8449B	3008A02310	1GHz ~ 26.5GHz	Jan. 16, 2017	Radiation (03CH01-CB)
Pre-Amplifier	MITEQ	TTA1840-35-HG	1864479	18GHz ~ 40GHz	Jun. 28, 2016	Radiation (03CH01-CB)
Spectrum Analyzer	R&S	FSP40	100056	9kHz ~ 40GHz	Nov. 22, 2016	Radiation (03CH01-CB)
EMI Test	R&S	ESCS	100355	9kHz ~ 2.75GHz	May 16, 2016	Radiation (03CH01-CB)
RF Cable-low	Woken	Low Cable-16+17	N/A	30 MHz ~ 1 GHz	Oct. 24, 2016	Radiation (03CH01-CB)
RF Cable-high	Woken	High Cable-16	N/A	1 GHz ~ 18 GHz	Oct. 24, 2016	Radiation (03CH01-CB)
RF Cable-high	Woken	High Cable-16+17	N/A	1 GHz ~ 18 GHz	Oct. 24, 2016	Radiation (03CH01-CB)
RF Cable-high	Woken	High Cable-40G#1	N/A	18GHz ~ 40 GHz	Oct. 24, 2016	Radiation (03CH01-CB)
RF Cable-high	Woken	High Cable-40G#2	N/A	18GHz ~ 40 GHz	Oct. 24, 2016	Radiation (03CH01-CB)
Test Software	Audix	E3	6.2009-10-7	N/A	N/A	Radiation (03CH01-CB)
Loop Antenna	Teseq	HLA 6120	24155	9kHz - 30 MHz	Mar. 16, 2016*	Radiation (03CH01-CB)
Spectrum analyzer	R&S	FSV40	100979	9kHz~40GHz	Dec. 26, 2016	Conducted (TH01-CB)
RF Cable-high	Woken	RG402	High Cable-6	1 GHz – 26.5 GHz	Oct. 24, 2016	Conducted (TH01-CB)
RF Cable-high	Woken	RG402	High Cable-7	1 GHz –26.5 GHz	Oct. 24, 2016	Conducted (TH01-CB)



Instrument	Manufacturer	Model No.	Serial No.	Characteristics	Calibration Date	Remark
RF Cable-high	Woken	RG402	High Cable-8	1 GHz –26.5 GHz	Oct. 24, 2016	Conducted (TH01-CB)
RF Cable-high	Woken	RG402	High Cable-9	1 GHz –26.5 GHz	Oct. 24, 2016	Conducted (TH01-CB)
RF Cable-high	Woken	RG402	High Cable-10	1 GHz –26.5 GHz	Oct. 24, 2016	Conducted (TH01-CB)
Power Sensor	Agilent	U2021XA	MY53410001	50MHz~18GHz	Nov. 22, 2016	Conducted (TH01-CB)

Note: Calibration Interval of instruments listed above is one year.

“*” Calibration Interval of instruments listed above is two years.

N.C.R means Non-Calibration required.



AC Power-line Conducted Emissions Result

Appendix A

AC Power-line Conducted Emissions Result																																																																																																																																																																																							
Operating Mode	1	Power Phase	Neutral																																																																																																																																																																																				
Operating Function	Normal Link																																																																																																																																																																																						
<p>The graph displays the AC power-line conducted emissions. The y-axis represents Level in dBuV (0 to 80), and the x-axis represents Frequency in MHz (0.150.2 to 30). Two red lines indicate CISPR limits: CISPR_B_QP (Quasi-Peak) and CISPR_B_AV (Average). A blue line shows the test results, which are generally below the limits. Vertical blue lines mark specific frequency points corresponding to the data table below.</p>																																																																																																																																																																																							
<table border="1"> <thead> <tr> <th></th> <th>Freq</th> <th>Level</th> <th>Over</th> <th>Limit</th> <th>Read</th> <th>LISN</th> <th>Cable</th> <th>Remark</th> <th>Pol/Phase</th> </tr> <tr> <th></th> <th>MHz</th> <th>dBuV</th> <th>dB</th> <th>dBuV</th> <th>dBuV</th> <th>dB</th> <th>dB</th> <th></th> <th></th> </tr> </thead> <tbody> <tr><td>1</td><td>0.1516</td><td>34.98</td><td>-20.93</td><td>55.91</td><td>25.00</td><td>9.94</td><td>0.04</td><td>Average</td><td>NEUTRAL</td></tr> <tr><td>2</td><td>0.1516</td><td>45.06</td><td>-20.85</td><td>65.91</td><td>35.08</td><td>9.94</td><td>0.04</td><td>QP</td><td>NEUTRAL</td></tr> <tr><td>3</td><td>0.1864</td><td>35.53</td><td>-18.67</td><td>54.20</td><td>25.51</td><td>9.97</td><td>0.05</td><td>Average</td><td>NEUTRAL</td></tr> <tr><td>4</td><td>0.1864</td><td>46.34</td><td>-17.86</td><td>64.20</td><td>36.32</td><td>9.97</td><td>0.05</td><td>QP</td><td>NEUTRAL</td></tr> <tr><td>5</td><td>0.5493</td><td>30.48</td><td>-15.52</td><td>46.00</td><td>20.47</td><td>9.97</td><td>0.04</td><td>Average</td><td>NEUTRAL</td></tr> <tr><td>6</td><td>0.5493</td><td>39.69</td><td>-16.31</td><td>56.00</td><td>29.68</td><td>9.97</td><td>0.04</td><td>QP</td><td>NEUTRAL</td></tr> <tr><td>7</td><td>4.7213</td><td>30.03</td><td>-15.97</td><td>46.00</td><td>19.80</td><td>10.09</td><td>0.14</td><td>Average</td><td>NEUTRAL</td></tr> <tr><td>8</td><td>4.7213</td><td>38.19</td><td>-17.81</td><td>56.00</td><td>27.96</td><td>10.09</td><td>0.14</td><td>QP</td><td>NEUTRAL</td></tr> <tr><td>9</td><td>5.8358</td><td>32.60</td><td>-17.40</td><td>50.00</td><td>22.34</td><td>10.11</td><td>0.15</td><td>Average</td><td>NEUTRAL</td></tr> <tr><td>10</td><td>5.8358</td><td>39.57</td><td>-20.43</td><td>60.00</td><td>29.31</td><td>10.11</td><td>0.15</td><td>QP</td><td>NEUTRAL</td></tr> <tr><td>11</td><td>15.0656</td><td>27.01</td><td>-22.99</td><td>50.00</td><td>16.55</td><td>10.24</td><td>0.22</td><td>Average</td><td>NEUTRAL</td></tr> <tr><td>12</td><td>15.0656</td><td>38.44</td><td>-21.56</td><td>60.00</td><td>27.98</td><td>10.24</td><td>0.22</td><td>QP</td><td>NEUTRAL</td></tr> <tr><td>13</td><td>17.9441</td><td>29.25</td><td>-20.75</td><td>50.00</td><td>18.74</td><td>10.27</td><td>0.24</td><td>Average</td><td>NEUTRAL</td></tr> <tr><td>14</td><td>17.9441</td><td>38.71</td><td>-21.29</td><td>60.00</td><td>28.20</td><td>10.27</td><td>0.24</td><td>QP</td><td>NEUTRAL</td></tr> <tr><td>15</td><td>22.1801</td><td>30.06</td><td>-19.94</td><td>50.00</td><td>19.50</td><td>10.30</td><td>0.26</td><td>Average</td><td>NEUTRAL</td></tr> <tr><td>16</td><td>22.1801</td><td>38.50</td><td>-21.50</td><td>60.00</td><td>27.94</td><td>10.30</td><td>0.26</td><td>QP</td><td>NEUTRAL</td></tr> </tbody> </table>					Freq	Level	Over	Limit	Read	LISN	Cable	Remark	Pol/Phase		MHz	dBuV	dB	dBuV	dBuV	dB	dB			1	0.1516	34.98	-20.93	55.91	25.00	9.94	0.04	Average	NEUTRAL	2	0.1516	45.06	-20.85	65.91	35.08	9.94	0.04	QP	NEUTRAL	3	0.1864	35.53	-18.67	54.20	25.51	9.97	0.05	Average	NEUTRAL	4	0.1864	46.34	-17.86	64.20	36.32	9.97	0.05	QP	NEUTRAL	5	0.5493	30.48	-15.52	46.00	20.47	9.97	0.04	Average	NEUTRAL	6	0.5493	39.69	-16.31	56.00	29.68	9.97	0.04	QP	NEUTRAL	7	4.7213	30.03	-15.97	46.00	19.80	10.09	0.14	Average	NEUTRAL	8	4.7213	38.19	-17.81	56.00	27.96	10.09	0.14	QP	NEUTRAL	9	5.8358	32.60	-17.40	50.00	22.34	10.11	0.15	Average	NEUTRAL	10	5.8358	39.57	-20.43	60.00	29.31	10.11	0.15	QP	NEUTRAL	11	15.0656	27.01	-22.99	50.00	16.55	10.24	0.22	Average	NEUTRAL	12	15.0656	38.44	-21.56	60.00	27.98	10.24	0.22	QP	NEUTRAL	13	17.9441	29.25	-20.75	50.00	18.74	10.27	0.24	Average	NEUTRAL	14	17.9441	38.71	-21.29	60.00	28.20	10.27	0.24	QP	NEUTRAL	15	22.1801	30.06	-19.94	50.00	19.50	10.30	0.26	Average	NEUTRAL	16	22.1801	38.50	-21.50	60.00	27.94	10.30	0.26	QP	NEUTRAL
	Freq	Level	Over	Limit	Read	LISN	Cable	Remark	Pol/Phase																																																																																																																																																																														
	MHz	dBuV	dB	dBuV	dBuV	dB	dB																																																																																																																																																																																
1	0.1516	34.98	-20.93	55.91	25.00	9.94	0.04	Average	NEUTRAL																																																																																																																																																																														
2	0.1516	45.06	-20.85	65.91	35.08	9.94	0.04	QP	NEUTRAL																																																																																																																																																																														
3	0.1864	35.53	-18.67	54.20	25.51	9.97	0.05	Average	NEUTRAL																																																																																																																																																																														
4	0.1864	46.34	-17.86	64.20	36.32	9.97	0.05	QP	NEUTRAL																																																																																																																																																																														
5	0.5493	30.48	-15.52	46.00	20.47	9.97	0.04	Average	NEUTRAL																																																																																																																																																																														
6	0.5493	39.69	-16.31	56.00	29.68	9.97	0.04	QP	NEUTRAL																																																																																																																																																																														
7	4.7213	30.03	-15.97	46.00	19.80	10.09	0.14	Average	NEUTRAL																																																																																																																																																																														
8	4.7213	38.19	-17.81	56.00	27.96	10.09	0.14	QP	NEUTRAL																																																																																																																																																																														
9	5.8358	32.60	-17.40	50.00	22.34	10.11	0.15	Average	NEUTRAL																																																																																																																																																																														
10	5.8358	39.57	-20.43	60.00	29.31	10.11	0.15	QP	NEUTRAL																																																																																																																																																																														
11	15.0656	27.01	-22.99	50.00	16.55	10.24	0.22	Average	NEUTRAL																																																																																																																																																																														
12	15.0656	38.44	-21.56	60.00	27.98	10.24	0.22	QP	NEUTRAL																																																																																																																																																																														
13	17.9441	29.25	-20.75	50.00	18.74	10.27	0.24	Average	NEUTRAL																																																																																																																																																																														
14	17.9441	38.71	-21.29	60.00	28.20	10.27	0.24	QP	NEUTRAL																																																																																																																																																																														
15	22.1801	30.06	-19.94	50.00	19.50	10.30	0.26	Average	NEUTRAL																																																																																																																																																																														
16	22.1801	38.50	-21.50	60.00	27.94	10.30	0.26	QP	NEUTRAL																																																																																																																																																																														
<p>Note 1: ">20dB" means emission levels that exceed the level of 20 dB below the applicable limit. Note 2: "N/F" means Nothing Found emissions (No emissions were detected.)</p>																																																																																																																																																																																							



AC Power-line Conducted Emissions Result

Appendix A

AC Power-line Conducted Emissions Result																																																																																																																																																																													
Operating Mode	1	Power Phase	Line																																																																																																																																																																										
Operating Function	Normal Link																																																																																																																																																																												
<table border="1" style="width: 100%; border-collapse: collapse;"> <thead> <tr> <th></th> <th>Freq</th> <th>Level</th> <th>Over</th> <th>Limit</th> <th>Read</th> <th>LISN</th> <th>Cable</th> <th>Remark</th> <th>Pol/Phase</th> </tr> <tr> <th></th> <th>MHz</th> <th>dBuV</th> <th>Limit</th> <th>Line</th> <th>Level</th> <th>Factor</th> <th>Loss</th> <th></th> <th></th> </tr> <tr> <th></th> <th></th> <th></th> <th>dB</th> <th>dBuV</th> <th>dBuV</th> <th>dB</th> <th>dB</th> <th></th> <th></th> </tr> </thead> <tbody> <tr><td>1</td><td>0.1500</td><td>34.98</td><td>-21.02</td><td>56.00</td><td>24.99</td><td>9.95</td><td>0.04</td><td>Average</td><td>LINE</td></tr> <tr><td>2</td><td>0.1500</td><td>45.30</td><td>-20.70</td><td>66.00</td><td>35.31</td><td>9.95</td><td>0.04</td><td>QP</td><td>LINE</td></tr> <tr><td>3</td><td>0.1844</td><td>35.48</td><td>-18.80</td><td>54.28</td><td>25.49</td><td>9.94</td><td>0.05</td><td>Average</td><td>LINE</td></tr> <tr><td>4</td><td>0.1844</td><td>46.50</td><td>-17.78</td><td>64.28</td><td>36.51</td><td>9.94</td><td>0.05</td><td>QP</td><td>LINE</td></tr> <tr><td>5</td><td>0.2072</td><td>33.22</td><td>-20.10</td><td>53.32</td><td>23.24</td><td>9.93</td><td>0.05</td><td>Average</td><td>LINE</td></tr> <tr><td>6</td><td>0.2072</td><td>43.22</td><td>-20.10</td><td>63.32</td><td>33.24</td><td>9.93</td><td>0.05</td><td>QP</td><td>LINE</td></tr> <tr><td>7</td><td>0.5293</td><td>30.02</td><td>-15.98</td><td>46.00</td><td>20.07</td><td>9.91</td><td>0.04</td><td>Average</td><td>LINE</td></tr> <tr><td>8</td><td>0.5293</td><td>39.73</td><td>-16.27</td><td>56.00</td><td>29.78</td><td>9.91</td><td>0.04</td><td>QP</td><td>LINE</td></tr> <tr><td>9</td><td>3.2411</td><td>26.22</td><td>-19.78</td><td>46.00</td><td>16.14</td><td>9.97</td><td>0.11</td><td>Average</td><td>LINE</td></tr> <tr><td>10</td><td>3.2411</td><td>35.93</td><td>-20.07</td><td>56.00</td><td>25.85</td><td>9.97</td><td>0.11</td><td>QP</td><td>LINE</td></tr> <tr><td>11</td><td>6.1861</td><td>32.70</td><td>-17.30</td><td>50.00</td><td>22.55</td><td>10.00</td><td>0.15</td><td>Average</td><td>LINE</td></tr> <tr><td>12</td><td>6.1861</td><td>39.93</td><td>-20.07</td><td>60.00</td><td>29.78</td><td>10.00</td><td>0.15</td><td>QP</td><td>LINE</td></tr> <tr><td>13</td><td>22.0629</td><td>29.53</td><td>-20.47</td><td>50.00</td><td>19.01</td><td>10.26</td><td>0.26</td><td>Average</td><td>LINE</td></tr> <tr><td>14</td><td>22.0629</td><td>38.29</td><td>-21.71</td><td>60.00</td><td>27.77</td><td>10.26</td><td>0.26</td><td>QP</td><td>LINE</td></tr> </tbody> </table>					Freq	Level	Over	Limit	Read	LISN	Cable	Remark	Pol/Phase		MHz	dBuV	Limit	Line	Level	Factor	Loss						dB	dBuV	dBuV	dB	dB			1	0.1500	34.98	-21.02	56.00	24.99	9.95	0.04	Average	LINE	2	0.1500	45.30	-20.70	66.00	35.31	9.95	0.04	QP	LINE	3	0.1844	35.48	-18.80	54.28	25.49	9.94	0.05	Average	LINE	4	0.1844	46.50	-17.78	64.28	36.51	9.94	0.05	QP	LINE	5	0.2072	33.22	-20.10	53.32	23.24	9.93	0.05	Average	LINE	6	0.2072	43.22	-20.10	63.32	33.24	9.93	0.05	QP	LINE	7	0.5293	30.02	-15.98	46.00	20.07	9.91	0.04	Average	LINE	8	0.5293	39.73	-16.27	56.00	29.78	9.91	0.04	QP	LINE	9	3.2411	26.22	-19.78	46.00	16.14	9.97	0.11	Average	LINE	10	3.2411	35.93	-20.07	56.00	25.85	9.97	0.11	QP	LINE	11	6.1861	32.70	-17.30	50.00	22.55	10.00	0.15	Average	LINE	12	6.1861	39.93	-20.07	60.00	29.78	10.00	0.15	QP	LINE	13	22.0629	29.53	-20.47	50.00	19.01	10.26	0.26	Average	LINE	14	22.0629	38.29	-21.71	60.00	27.77	10.26	0.26	QP	LINE
	Freq	Level	Over	Limit	Read	LISN	Cable	Remark	Pol/Phase																																																																																																																																																																				
	MHz	dBuV	Limit	Line	Level	Factor	Loss																																																																																																																																																																						
			dB	dBuV	dBuV	dB	dB																																																																																																																																																																						
1	0.1500	34.98	-21.02	56.00	24.99	9.95	0.04	Average	LINE																																																																																																																																																																				
2	0.1500	45.30	-20.70	66.00	35.31	9.95	0.04	QP	LINE																																																																																																																																																																				
3	0.1844	35.48	-18.80	54.28	25.49	9.94	0.05	Average	LINE																																																																																																																																																																				
4	0.1844	46.50	-17.78	64.28	36.51	9.94	0.05	QP	LINE																																																																																																																																																																				
5	0.2072	33.22	-20.10	53.32	23.24	9.93	0.05	Average	LINE																																																																																																																																																																				
6	0.2072	43.22	-20.10	63.32	33.24	9.93	0.05	QP	LINE																																																																																																																																																																				
7	0.5293	30.02	-15.98	46.00	20.07	9.91	0.04	Average	LINE																																																																																																																																																																				
8	0.5293	39.73	-16.27	56.00	29.78	9.91	0.04	QP	LINE																																																																																																																																																																				
9	3.2411	26.22	-19.78	46.00	16.14	9.97	0.11	Average	LINE																																																																																																																																																																				
10	3.2411	35.93	-20.07	56.00	25.85	9.97	0.11	QP	LINE																																																																																																																																																																				
11	6.1861	32.70	-17.30	50.00	22.55	10.00	0.15	Average	LINE																																																																																																																																																																				
12	6.1861	39.93	-20.07	60.00	29.78	10.00	0.15	QP	LINE																																																																																																																																																																				
13	22.0629	29.53	-20.47	50.00	19.01	10.26	0.26	Average	LINE																																																																																																																																																																				
14	22.0629	38.29	-21.71	60.00	27.77	10.26	0.26	QP	LINE																																																																																																																																																																				
<p>Note 1: ">20dB" means emission levels that exceed the level of 20 dB below the applicable limit. Note 2: "N/F" means Nothing Found emissions (No emissions were detected.)</p>																																																																																																																																																																													



Summary

Mode	Max-N dB (Hz)	Max-OBW (Hz)	ITU-Code	Min-N dB (Hz)	Min-OBW (Hz)
LoRa_Nss1_1TX	-	-	-	-	-
902-928MHz	773.75k	576.587k	577kD1D	754.375k	533.483k

Max-N dB = Maximum 6dB down bandwidth; **Max-OBW** = Maximum 99% occupied bandwidth;
Min-N dB = Minimum 6dB down bandwidth; **Min-OBW** = Minimum 99% occupied bandwidth;

Result

Mode	Result	Limit (Hz)	Port 1-N dB (Hz)	Port 1-OBW (Hz)
LoRa_Nss1_1TX	-	-	-	-
903MHz	Pass	500k	760k	575.962k
907.8MHz	Pass	500k	754.375k	552.224k
914.2MHz	Pass	500k	759.375k	576.587k
923.3MHz	Pass	500k	773.75k	567.841k
925.1MHz	Pass	500k	765.625k	533.483k
927.5MHz	Pass	500k	770k	574.713k

Port X-N dB = Port X 6dB down bandwidth; **Port X-OBW** = Port X 99% occupied bandwidth;

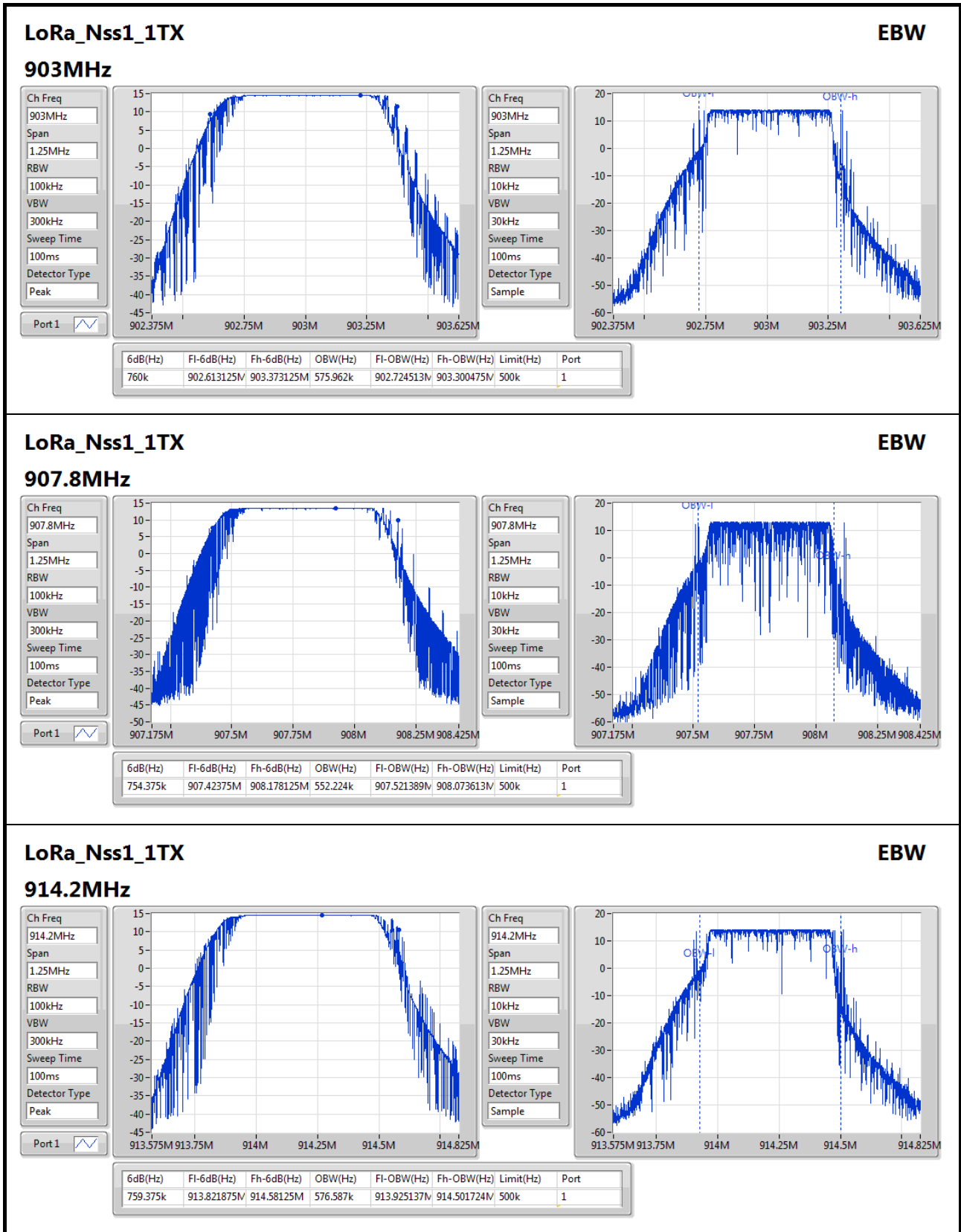

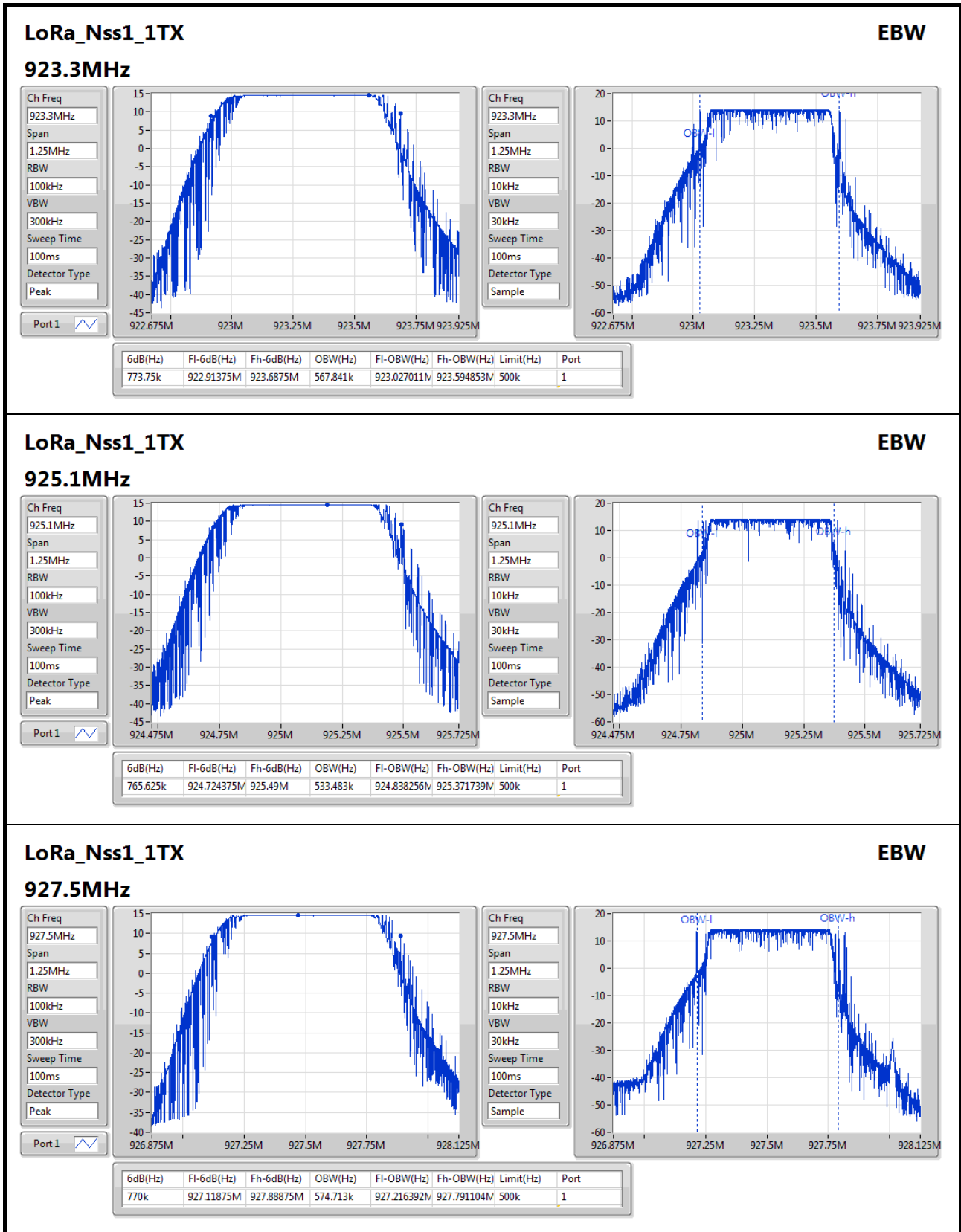



Summary

Mode	Total Power (dBm)	Total Power (W)
LoRa_500kHz	-	-
902-928MHz	18.42	0.06950

Result

Mode	Result	DG (dBi)	Port 1 (dBm)	Total Power (dBm)	Power Limit (dBm)
LoRa_500kHz	-	-	-	-	-
903MHz	Pass	1.80	18.33	18.33	30.00
907.8MHz	Pass	1.80	18.35	18.35	30.00
914.2MHz	Pass	1.80	18.38	18.38	30.00
923.3MHz	Pass	1.80	18.41	18.41	30.00
925.1MHz	Pass	1.80	18.39	18.39	30.00
927.5MHz	Pass	1.80	18.42	18.42	30.00

DG = Directional Gain; Port X = Port X output power



Summary

Mode	PD (dBm/RBW)
LoRa_500kHz	-
902-928MHz	0.69

RBW=3kHz.

Result

Mode	Result	DG (dBi)	Port 1 (dBm/RBW)	PD (dBm/RBW)	PD Limit (dBm/RBW)
LoRa_500kHz	-	-	-	-	-
903MHz	Pass	1.80	0.52	0.52	8.00
907.8MHz	Pass	1.80	0.34	0.34	8.00
914.2MHz	Pass	1.80	0.61	0.61	8.00
923.3MHz	Pass	1.80	0.03	0.03	8.00
925.1MHz	Pass	1.80	0.69	0.69	8.00
927.5MHz	Pass	1.80	0.26	0.26	8.00

DG = Directional Gain; RBW=3kHz;

PD = trace bin-by-bin of each transmits port summing can be performed maximum power density; **Port X** = Port X power density;

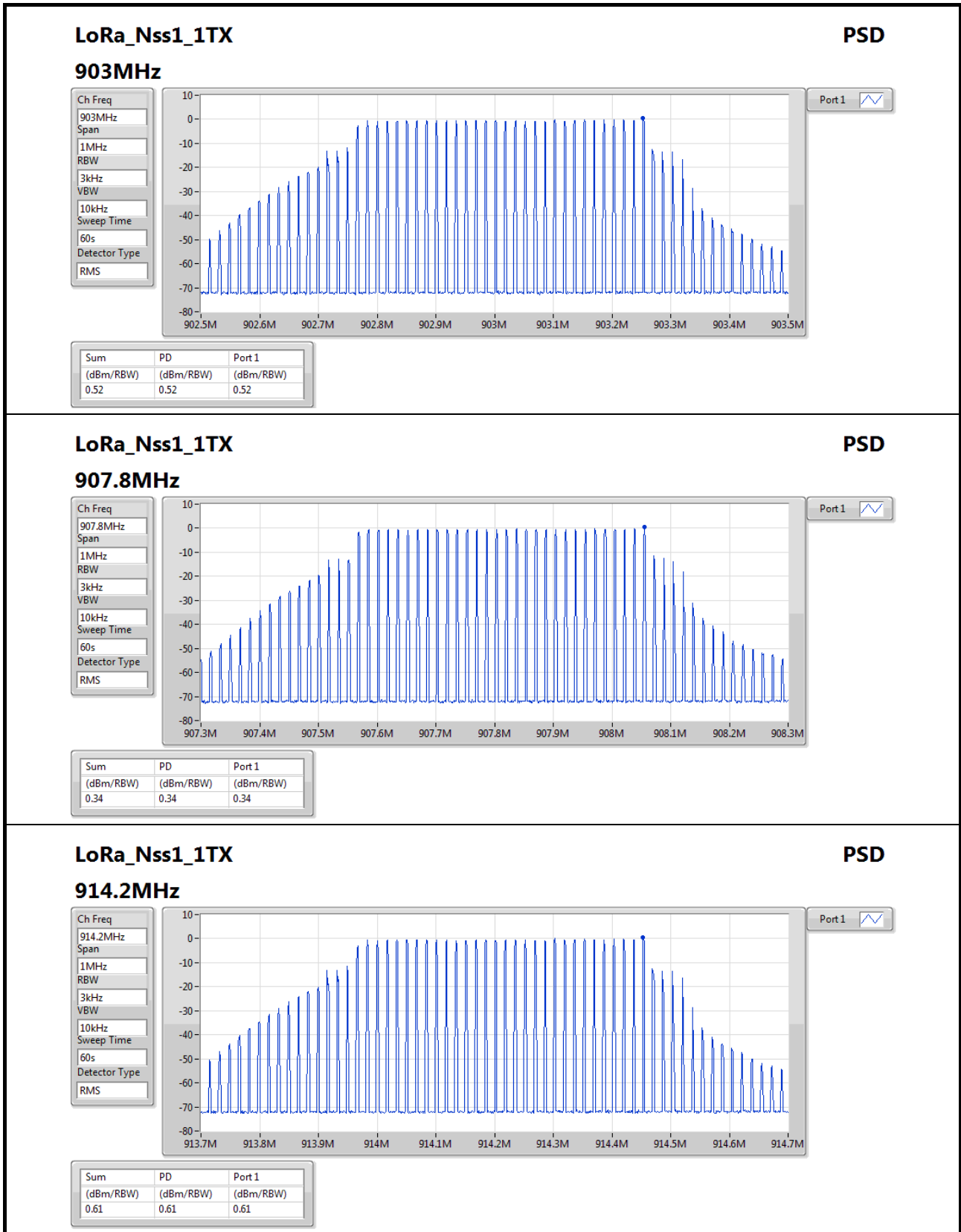

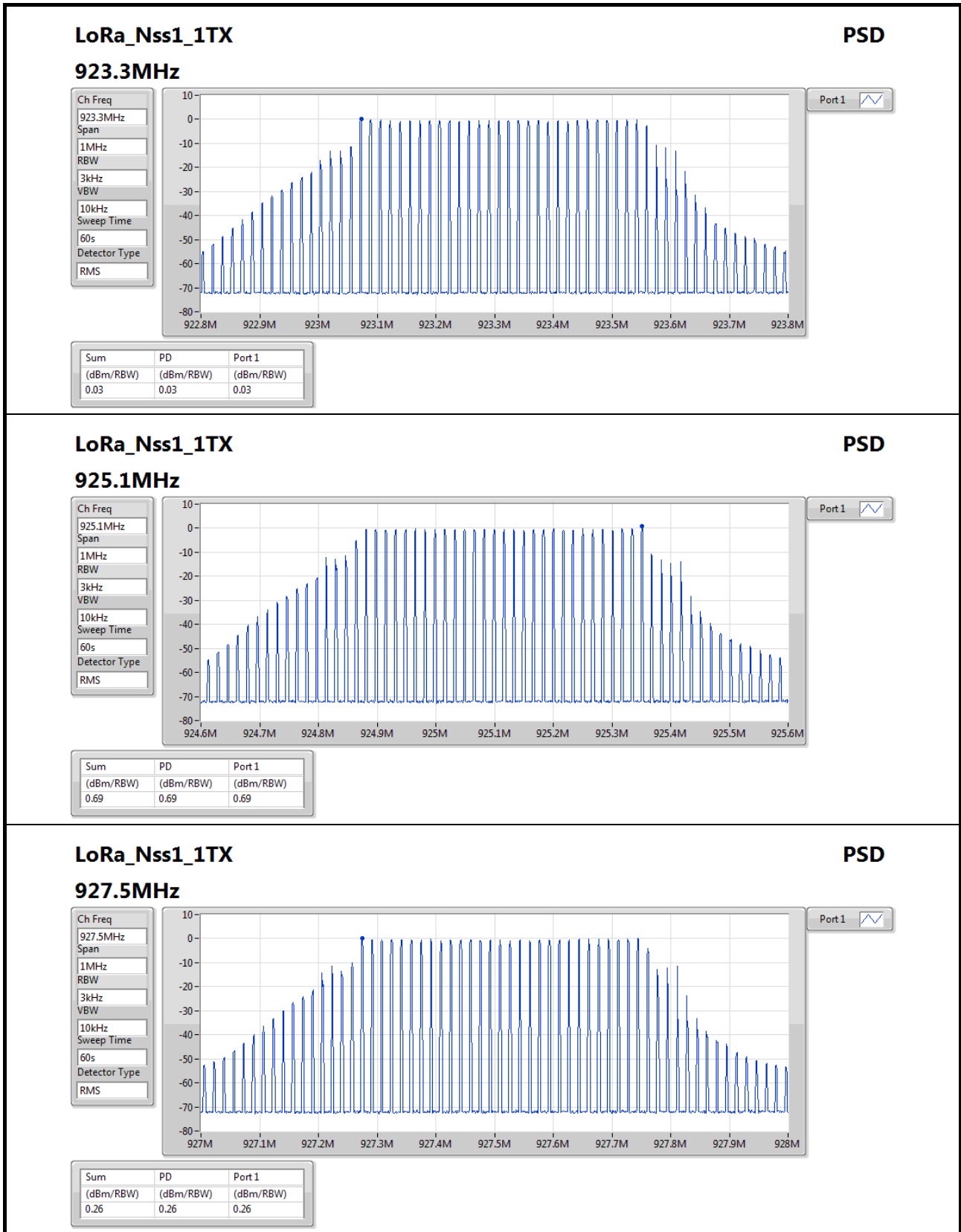



Summary

Mode	Result	Ref (Hz)	Ref (dBm)	Limit (dBm)	Freq (Hz)	Level (dBm)	Freq (Hz)	Level (dBm)	Freq (Hz)	Level (dBm)	Freq (Hz)	Level (dBm)	Port
LoRa_Nss1_1TX	-	-	-	-	-	-	-	-	-	-	-	-	-
902-928MHz	Pass	925.244M	14.66	-15.34	833.062M	-58.86	901M	-58.83	928.042M	-19.18	6.918128G	-53.95	1

Result

Mode	Result	Ref (Hz)	Ref (dBm)	Limit (dBm)	Freq (Hz)	Level (dBm)	Freq (Hz)	Level (dBm)	Freq (Hz)	Level (dBm)	Freq (Hz)	Level (dBm)	Port
LoRa_Nss1_1TX	-	-	-	-	-	-	-	-	-	-	-	-	-
903MHz	Pass	907.72M	13.75	-16.25	844.8205M	-58.54	901.95M	-46.82	928.39M	-58.54	7.22314G	-50.77	1
907.8MHz	Pass	907.72M	13.75	-16.25	864.8535M	-59.85	901.718M	-57.84	928.31M	-58.55	6.962349G	-52.78	1
914.2MHz	Pass	907.72M	13.75	-16.25	829.1425M	-59.25	901.22M	-57.87	928.374M	-57.92	6.819481G	-53.05	1
923.3MHz	Pass	925.244M	14.66	-15.34	30M	-58.83	901.212M	-58.24	928.446M	-56.74	9.234634G	-50.72	1
925.1MHz	Pass	925.244M	14.66	-15.34	779.06M	-58.38	901.26M	-58.27	928.176M	-54.36	6.3716G	-53.43	1
927.5MHz	Pass	925.244M	14.66	-15.34	833.062M	-58.86	901M	-58.83	928.042M	-19.18	6.918128G	-53.95	1

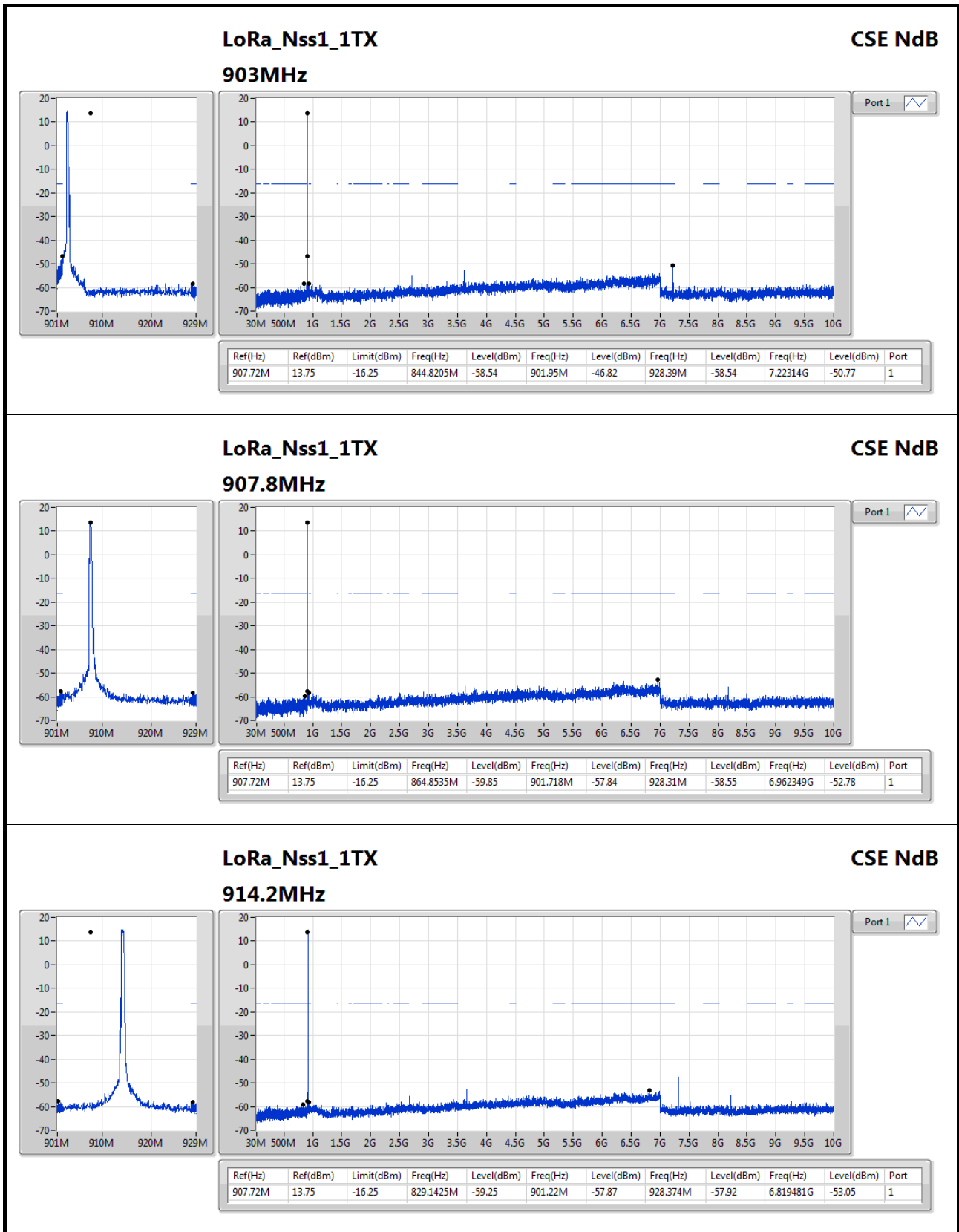
LoRa_Nss1_1TX
CSE NdB

914.2MHz



Port1

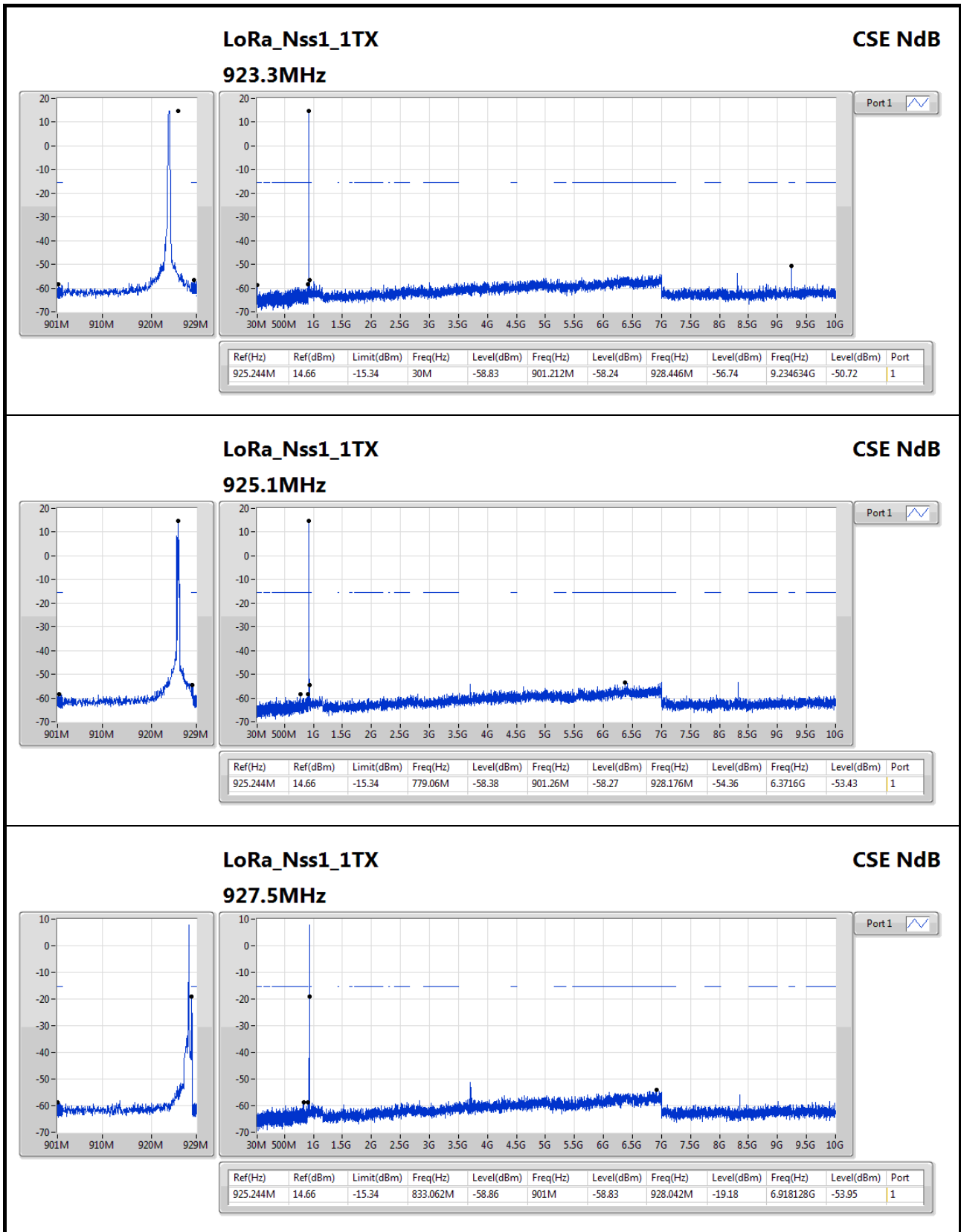



RSE below 1GHz Result

RSE below 1GHz Result																																																																																																			
Operating Mode	3	Polarization	Horizontal																																																																																																
Operating Function	Normal Link																																																																																																		
<div style="display: flex; justify-content: space-between;"> <div> <p>Level (dBuV/m)</p> <p style="text-align: right;">Date: 2017-02-18 Time: 18:49:13</p> </div> <div style="text-align: right;"> <p>FCC CLASS-B</p> <p>5dB</p> </div> </div>																																																																																																			
<table border="1" style="width: 100%; border-collapse: collapse;"> <thead> <tr> <th></th> <th>Freq</th> <th>Level</th> <th>Limit</th> <th>Over</th> <th>Read</th> <th>CableAntenna</th> <th>Preamp</th> <th>A/Pos</th> <th>T/Pos</th> <th>Remark</th> <th>Pol/Phase</th> </tr> <tr> <th></th> <th>MHz</th> <th>dBuV/m</th> <th>dBuV/m</th> <th>dB</th> <th>dBuV</th> <th>dB</th> <th>dB/m</th> <th>dB</th> <th>cm</th> <th>deg</th> <th></th> </tr> </thead> <tbody> <tr> <td>1</td> <td>73.65</td> <td>33.57</td> <td>40.00</td> <td>-6.43</td> <td>52.02</td> <td>0.81</td> <td>13.16</td> <td>32.42</td> <td>200</td> <td>210 Peak</td> <td>HORIZONTAL</td> </tr> <tr> <td>2</td> <td>127.00</td> <td>34.94</td> <td>43.50</td> <td>-8.56</td> <td>47.39</td> <td>1.08</td> <td>18.88</td> <td>32.41</td> <td>300</td> <td>358 Peak</td> <td>HORIZONTAL</td> </tr> <tr> <td>3</td> <td>143.49</td> <td>35.42</td> <td>43.50</td> <td>-8.08</td> <td>48.78</td> <td>1.14</td> <td>17.89</td> <td>32.39</td> <td>200</td> <td>162 Peak</td> <td>HORIZONTAL</td> </tr> <tr> <td>4</td> <td>294.81</td> <td>38.96</td> <td>46.00</td> <td>-7.04</td> <td>49.75</td> <td>1.64</td> <td>19.90</td> <td>32.33</td> <td>100</td> <td>267 Peak</td> <td>HORIZONTAL</td> </tr> <tr> <td>5</td> <td>306.45</td> <td>39.70</td> <td>46.00</td> <td>-6.30</td> <td>50.16</td> <td>1.68</td> <td>20.19</td> <td>32.33</td> <td>100</td> <td>319 Peak</td> <td>HORIZONTAL</td> </tr> <tr> <td>6</td> <td>657.59</td> <td>35.02</td> <td>46.00</td> <td>-10.98</td> <td>38.88</td> <td>2.46</td> <td>26.07</td> <td>32.39</td> <td>100</td> <td>208 Peak</td> <td>HORIZONTAL</td> </tr> </tbody> </table>					Freq	Level	Limit	Over	Read	CableAntenna	Preamp	A/Pos	T/Pos	Remark	Pol/Phase		MHz	dBuV/m	dBuV/m	dB	dBuV	dB	dB/m	dB	cm	deg		1	73.65	33.57	40.00	-6.43	52.02	0.81	13.16	32.42	200	210 Peak	HORIZONTAL	2	127.00	34.94	43.50	-8.56	47.39	1.08	18.88	32.41	300	358 Peak	HORIZONTAL	3	143.49	35.42	43.50	-8.08	48.78	1.14	17.89	32.39	200	162 Peak	HORIZONTAL	4	294.81	38.96	46.00	-7.04	49.75	1.64	19.90	32.33	100	267 Peak	HORIZONTAL	5	306.45	39.70	46.00	-6.30	50.16	1.68	20.19	32.33	100	319 Peak	HORIZONTAL	6	657.59	35.02	46.00	-10.98	38.88	2.46	26.07	32.39	100	208 Peak	HORIZONTAL
	Freq	Level	Limit	Over	Read	CableAntenna	Preamp	A/Pos	T/Pos	Remark	Pol/Phase																																																																																								
	MHz	dBuV/m	dBuV/m	dB	dBuV	dB	dB/m	dB	cm	deg																																																																																									
1	73.65	33.57	40.00	-6.43	52.02	0.81	13.16	32.42	200	210 Peak	HORIZONTAL																																																																																								
2	127.00	34.94	43.50	-8.56	47.39	1.08	18.88	32.41	300	358 Peak	HORIZONTAL																																																																																								
3	143.49	35.42	43.50	-8.08	48.78	1.14	17.89	32.39	200	162 Peak	HORIZONTAL																																																																																								
4	294.81	38.96	46.00	-7.04	49.75	1.64	19.90	32.33	100	267 Peak	HORIZONTAL																																																																																								
5	306.45	39.70	46.00	-6.30	50.16	1.68	20.19	32.33	100	319 Peak	HORIZONTAL																																																																																								
6	657.59	35.02	46.00	-10.98	38.88	2.46	26.07	32.39	100	208 Peak	HORIZONTAL																																																																																								
<p>Note 1: ">20dB" means emission levels that exceed the level of 20 dB below the applicable limit. Note 2: "N/F" means Nothing Found emissions (No emissions were detected.)</p>																																																																																																			



RSE below 1GHz Result

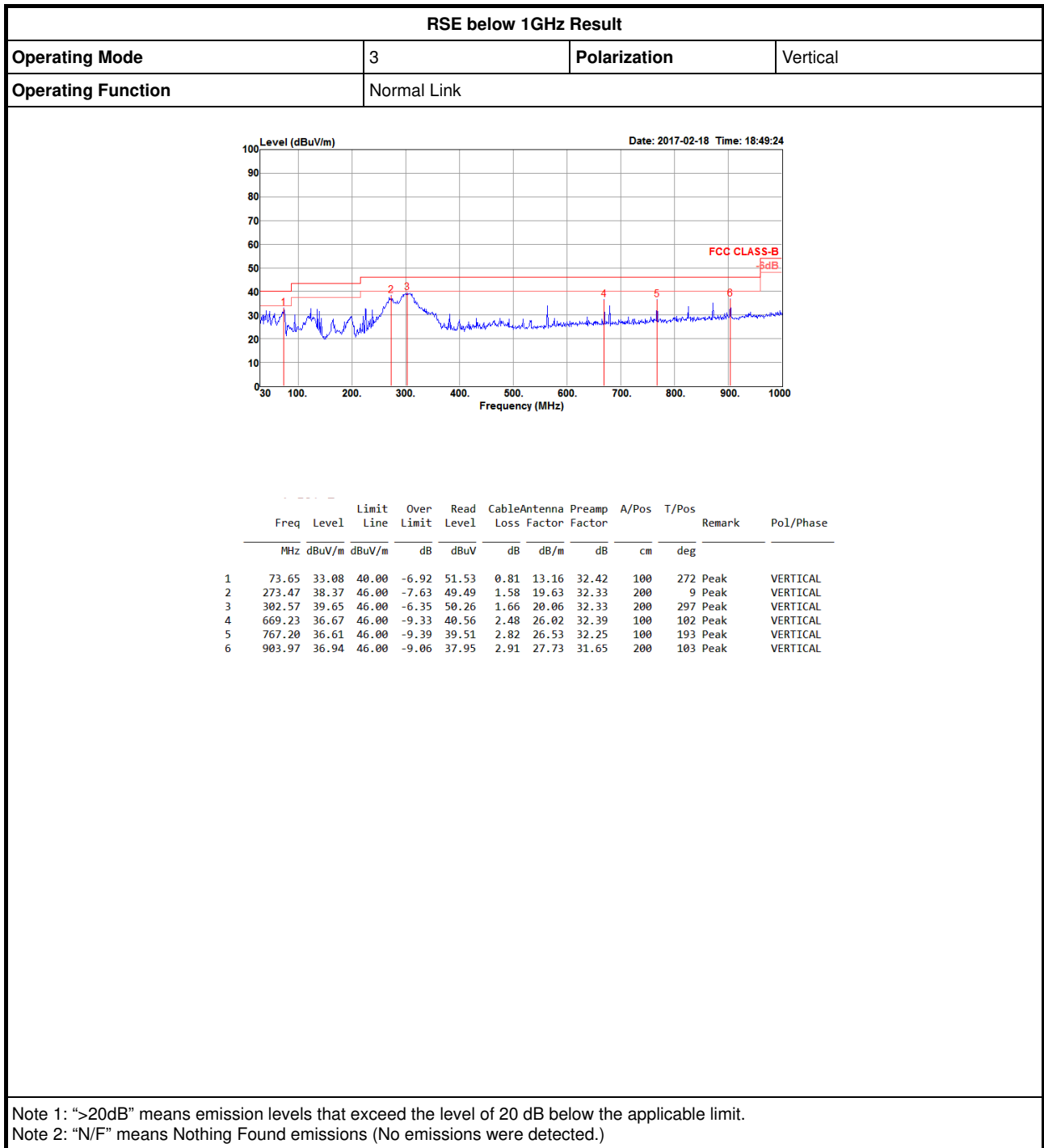



Summary

Mode	Result	Type	Freq (Hz)	Level (dBuV/m)	Limit (dBuV/m)	Margin (dB)	Factor (dB)	Dist (m)	Pol. (H/V)	Azimuth (°)	Height (m)	Comments
LoRa_Nss1_1TX	-	-	-	-	-	-	-	-	-	-	-	-
902-928MHz	Pass	AV	2.74282G	28.19	54.00	-25.81	-1.18	3	H	303	1.04	-

LoRa_Nss1_1TX

903MHz_TX

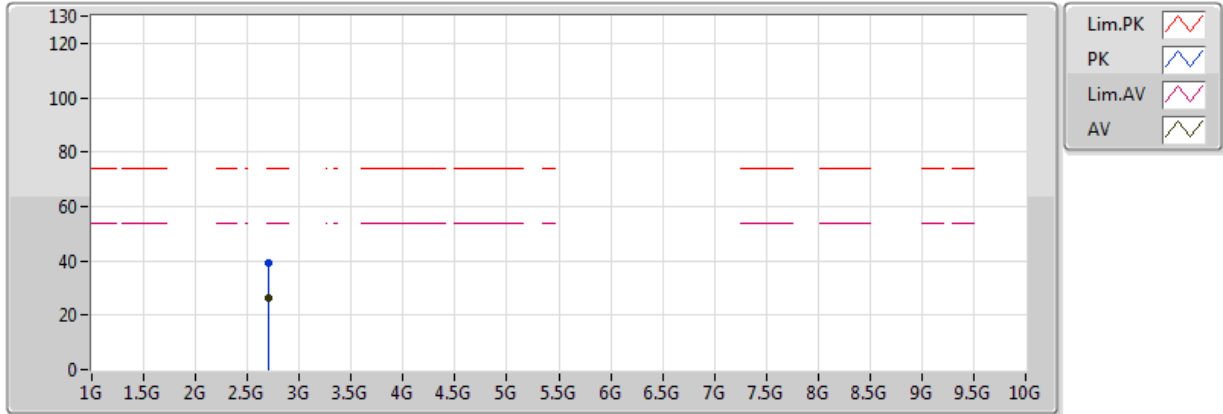

20170414
EUT_Z_1TX
Setting 20
03-P-2
FSP(100019)

Type	Freq(Hz)	Level(dBuV/m)	Limit(dBuV/m)	Margin(dB)	Factor(dB)	Dist(m)	Pol.(H/V)	Azimuth(°)	Height(m)	Comments
AV	2.70788G	26.18	54.00	-27.82	-1.31	3	V	327	1.28	-
PK	2.70957G	39.34	74.00	-34.66	-1.30	3	V	327	1.28	-

LoRa_Nss1_1TX

903MHz_TX

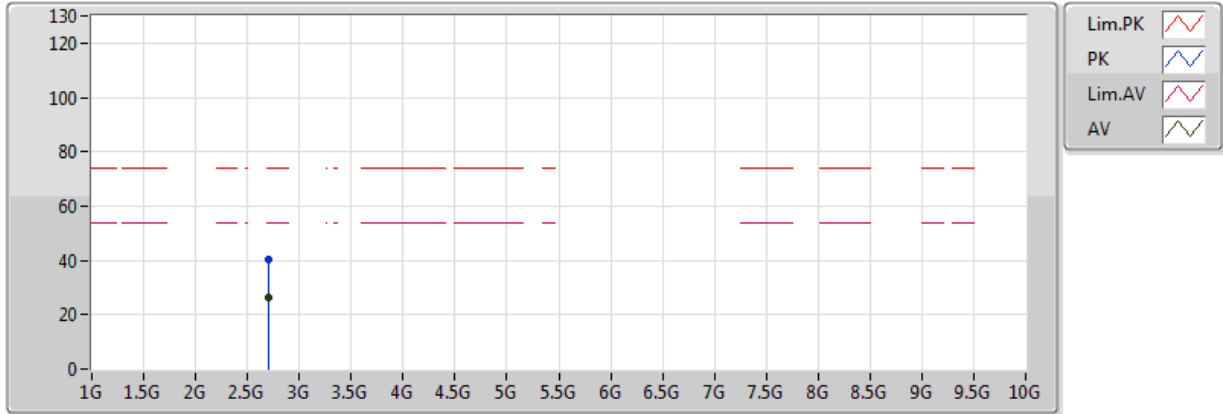

20170414
EUT_Z_1TX
Setting 20
03-P-2
FSP(100019)

Type	Freq(Hz)	Level(dBuV/m)	Limit(dBuV/m)	Margin(dB)	Factor(dB)	Dist(m)	Pol.(H/V)	Azimuth(°)	Height(m)	Comments
AV	2.70705G	26.14	54.00	-27.86	-1.31	3	H	266	1.35	-
PK	2.70782G	40.07	74.00	-33.93	-1.31	3	H	266	1.35	-

LoRa_Nss1_1TX

907.8MHz_TX

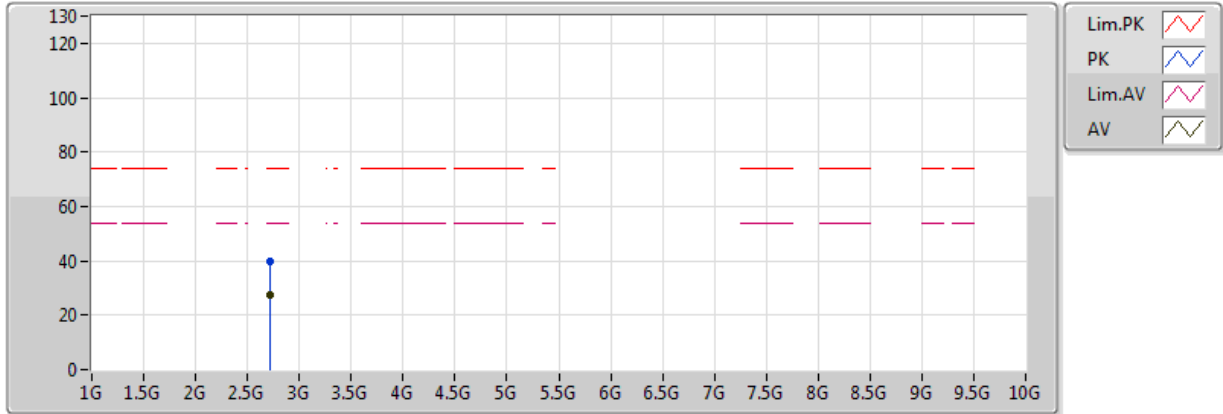

20170414
 EUT_Z_1TX
 Setting 20
 03-P-2
 FSP(100019)

Type	Freq(Hz)	Level(dBuV/m)	Limit(dBuV/m)	Margin(dB)	Factor(dB)	Dist(m)	Pol.(H/V)	Azimuth(°)	Height(m)	Comments
AV	2.72366G	27.45	54.00	-26.55	-1.25	3	V	186	2.50	-
PK	2.72411G	39.58	74.00	-34.42	-1.25	3	V	186	2.50	-

LoRa_Nss1_1TX

907.8MHz_TX

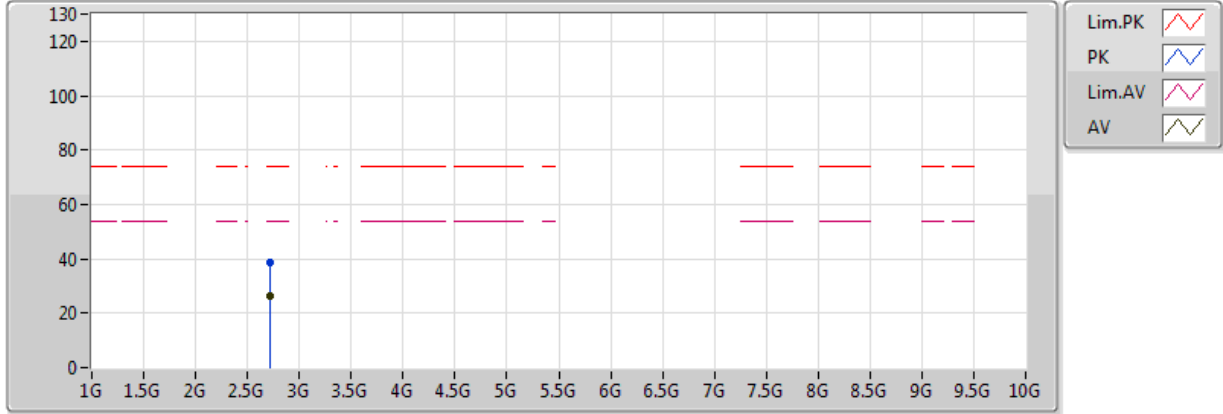

20170414
EUT_Z_1TX
Setting 20
03-P-2
FSP(100019)

Type	Freq(Hz)	Level(dBuV/m)	Limit(dBuV/m)	Margin(dB)	Factor(dB)	Dist(m)	Pol.(H/V)	Azimuth(°)	Height(m)	Comments
AV	2.72388G	26.38	54.00	-27.62	-1.25	3	H	186	2.50	-
PK	2.72262G	38.52	74.00	-35.48	-1.25	3	H	186	2.50	-



LoRa_Nss1_1TX

914.2MHz_TX

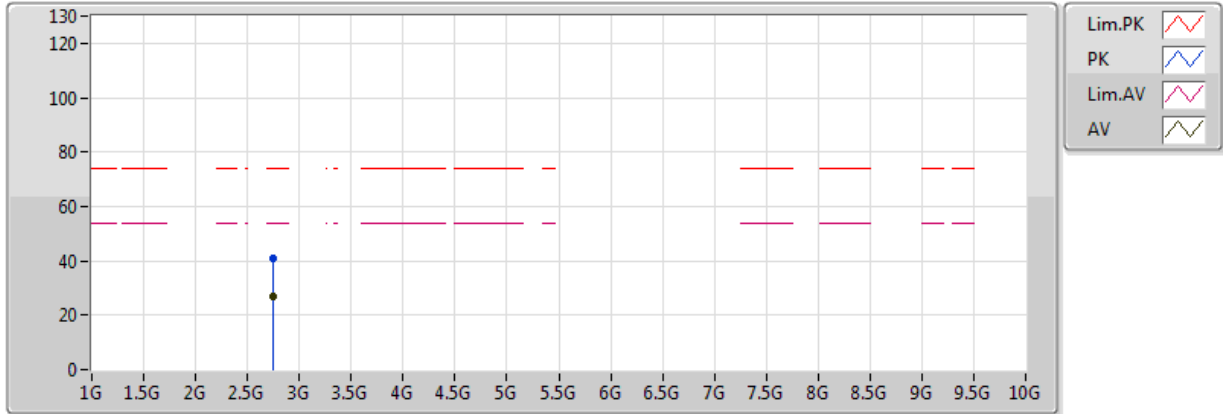

20170414
 EUT_Z_1TX
 Setting 20
 03-P-2
 FSP(100019)

Type	Freq(Hz)	Level(dBuV/m)	Limit(dBuV/m)	Margin(dB)	Factor(dB)	Dist(m)	Pol.(H/V)	Azimuth(°)	Height(m)	Comments
AV	2.7401G	27.11	54.00	-26.89	-1.19	3	V	45	1.09	-
PK	2.74368G	41.13	74.00	-32.87	-1.17	3	V	45	1.09	-

LoRa_Nss1_1TX

914.2MHz_TX

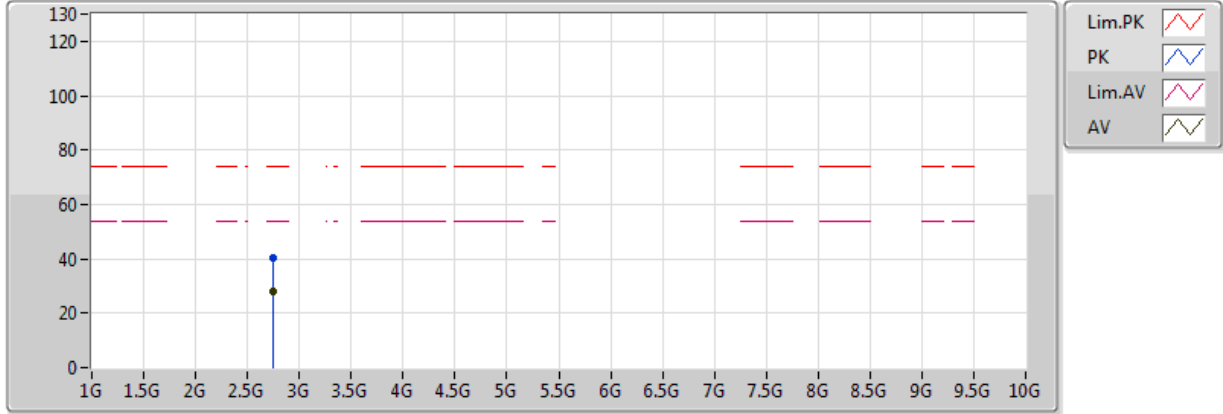

20170414
EUT_Z_1TX
Setting 20
03-P-2
FSP(100019)

Type	Freq(Hz)	Level(dBuV/m)	Limit(dBuV/m)	Margin(dB)	Factor(dB)	Dist(m)	Pol.(H/V)	Azimuth(°)	Height(m)	Comments
AV	2.74282G	28.19	54.00	-25.81	-1.18	3	H	303	1.04	-
PK	2.74279G	40.58	74.00	-33.42	-1.18	3	H	303	1.04	-

LoRa_Nss1_1TX

923.3MHz_TX

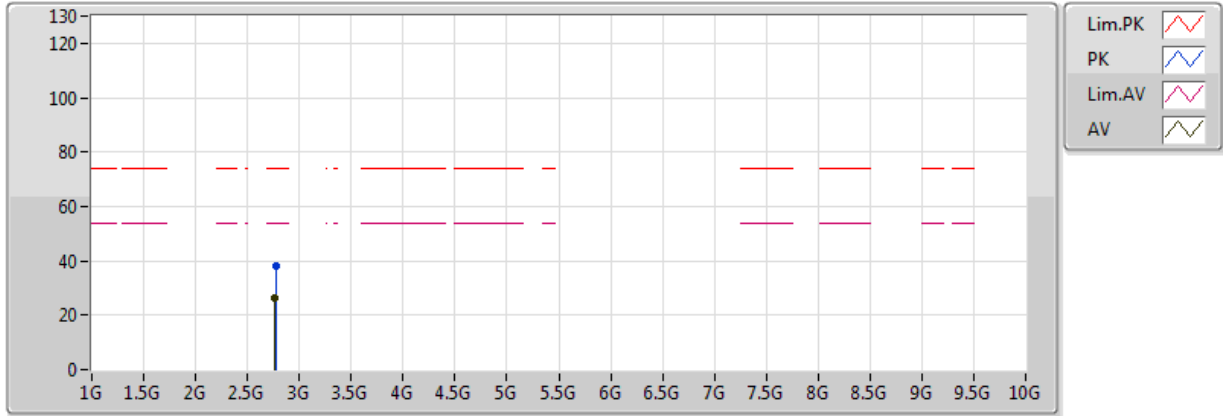

20170414
EUT_Z_1TX
Setting 20
03-P-2
FSP(100019)

Type	Freq(Hz)	Level(dBuV/m)	Limit(dBuV/m)	Margin(dB)	Factor(dB)	Dist(m)	Pol.(H/V)	Azimuth(°)	Height(m)	Comments
AV	2.76842G	26.27	54.00	-27.73	-1.08	3	V	129	2.01	-
PK	2.76977G	38.26	74.00	-35.74	-1.07	3	V	129	2.01	-

LoRa_Nss1_1TX

923.3MHz_TX

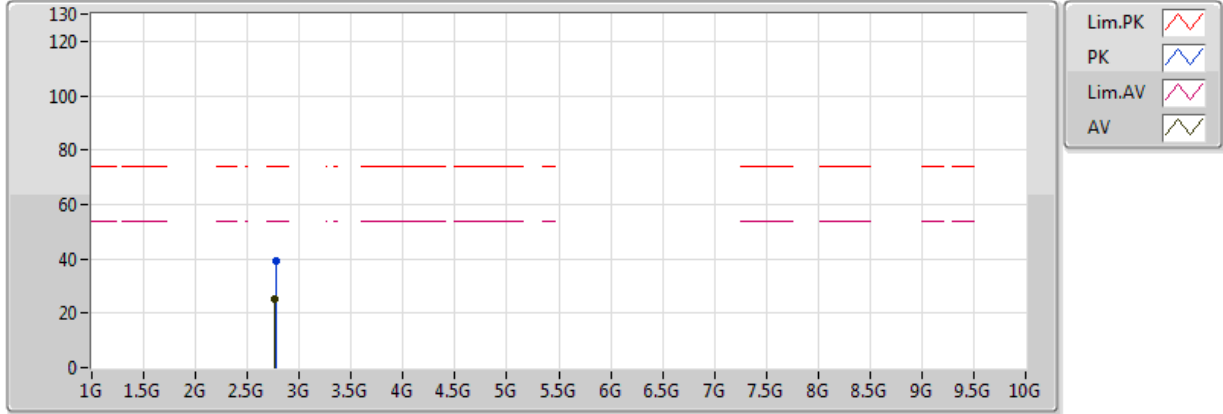

20170414
EUT_Z_1TX
Setting 20
03-P-2
FSP(100019)

Type	Freq(Hz)	Level(dBuV/m)	Limit(dBuV/m)	Margin(dB)	Factor(dB)	Dist(m)	Pol.(H/V)	Azimuth(°)	Height(m)	Comments
AV	2.76834G	25.28	54.00	-28.72	-1.08	3	H	243	1.56	-
PK	2.77122G	39.31	74.00	-34.69	-1.07	3	H	243	1.56	-

LoRa_Nss1_1TX

925.1MHz_TX

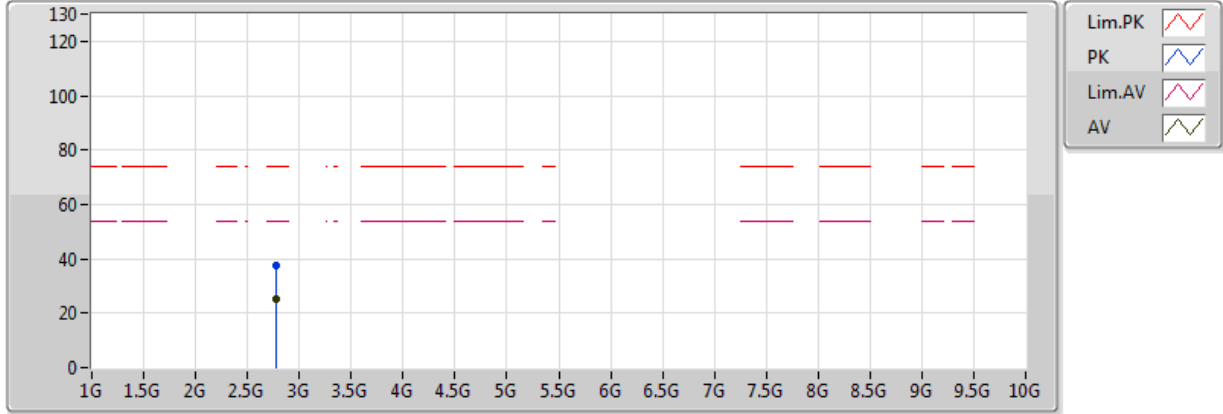

20170414
EUT_Z_1TX
Setting 20
03-P-2
FSP(100019)

Type	Freq(Hz)	Level(dBuV/m)	Limit(dBuV/m)	Margin(dB)	Factor(dB)	Dist(m)	Pol.(H/V)	Azimuth(°)	Height(m)	Comments
AV	2.77439G	25.28	54.00	-28.72	-1.06	3	V	203	1.05	-
PK	2.77542G	37.63	74.00	-36.37	-1.05	3	V	203	1.05	-

LoRa_Nss1_1TX

925.1MHz_TX

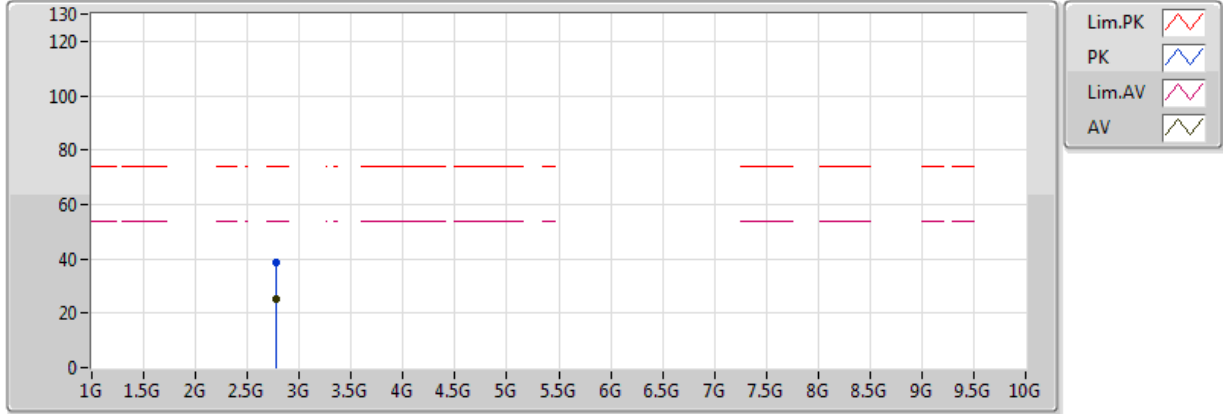

20170414
EUT_Z_1TX
Setting 20
03-P-2
FSP(100019)

Type	Freq(Hz)	Level(dBuV/m)	Limit(dBuV/m)	Margin(dB)	Factor(dB)	Dist(m)	Pol.(H/V)	Azimuth(°)	Height(m)	Comments
AV	2.77284G	25.39	54.00	-28.61	-1.06	3	H	193	1.95	-
PK	2.77489G	38.45	74.00	-35.55	-1.06	3	H	193	1.95	-

LoRa_Nss1_1TX

927.5MHz_TX

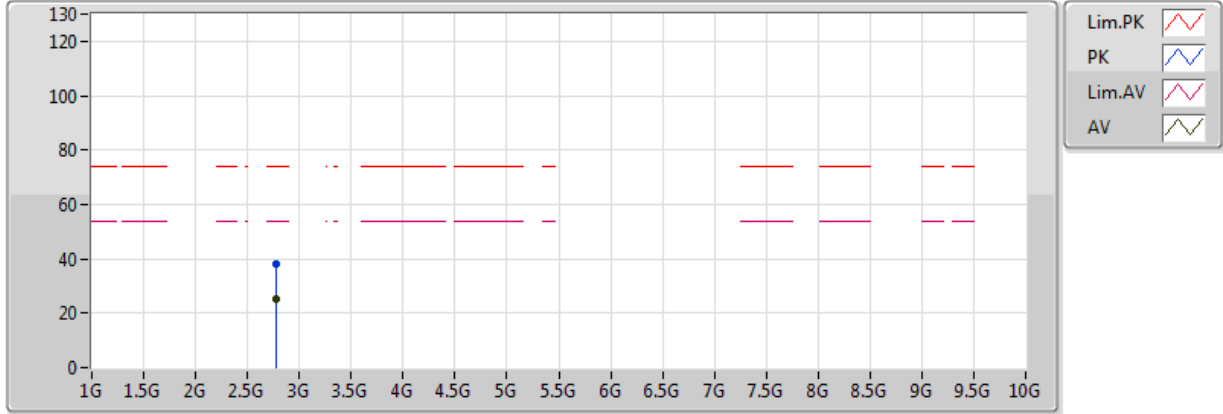

20170414
EUT_Z_1TX
Setting 20
03-P-2
FSP(100019)

Type	Freq(Hz)	Level(dBuV/m)	Limit(dBuV/m)	Margin(dB)	Factor(dB)	Dist(m)	Pol.(H/V)	Azimuth(°)	Height(m)	Comments
AV	2.78081G	25.11	54.00	-28.89	-1.03	3	V	85	1.32	-
PK	2.78251G	38.34	74.00	-35.66	-1.03	3	V	85	1.32	-

LoRa_Nss1_1TX

927.5MHz_TX

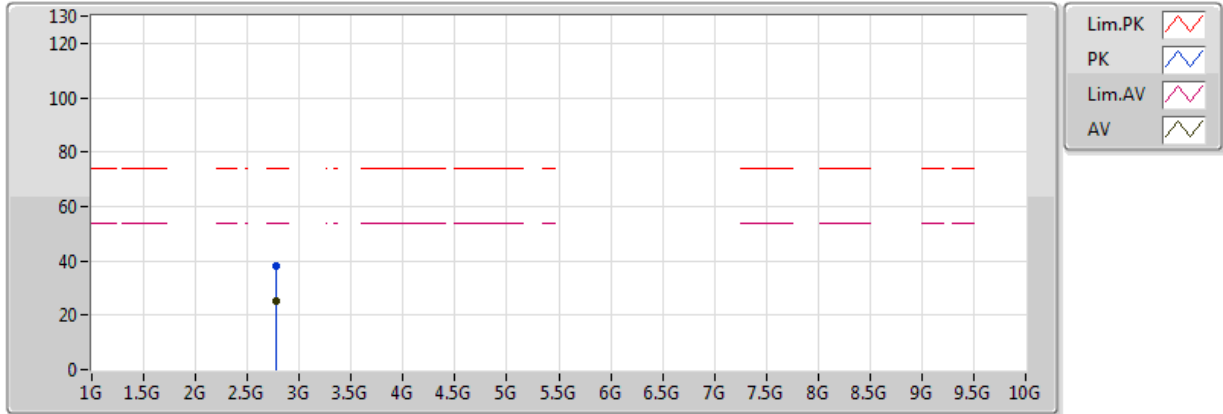

20170414
EUT_Z_1TX
Setting 20
03-P-2
FSP(100019)

Type	Freq(Hz)	Level(dBuV/m)	Limit(dBuV/m)	Margin(dB)	Factor(dB)	Dist(m)	Pol.(H/V)	Azimuth(°)	Height(m)	Comments
AV	2.78222G	24.97	54.00	-29.03	-1.03	3	H	98	1.07	-
PK	2.78191G	37.88	74.00	-36.12	-1.03	3	H	98	1.07	-



Summary

Mode	Max-N dB (Hz)	Max-OBW (Hz)	ITU-Code	Min-N dB (Hz)	Min-OBW (Hz)
LoRa_Nss1_1TX	-	-	-	-	-
902-928MHz	135.469k	123.844k	124kD1D	135.156k	123.688k

Max-N dB = Maximum 20dB down bandwidth; Max-OBW = Maximum 99% occupied bandwidth;
Min-N dB = Minimum 20dB down bandwidth; Min-OBW = Minimum 99% occupied bandwidth;

Result

Mode	Result	Limit (Hz)	Port 1-N dB (Hz)	Port 1-OBW (Hz)
LoRa_Nss1_1TX	-	-	-	-
902.3MHz	Pass	Inf	135.312k	123.688k
908.5MHz	Pass	Inf	135.469k	123.688k
914.9MHz	Pass	Inf	135.156k	123.844k

Port X-N dB = Port X 20dB down bandwidth; Port X-OBW = Port X 99% occupied bandwidth;

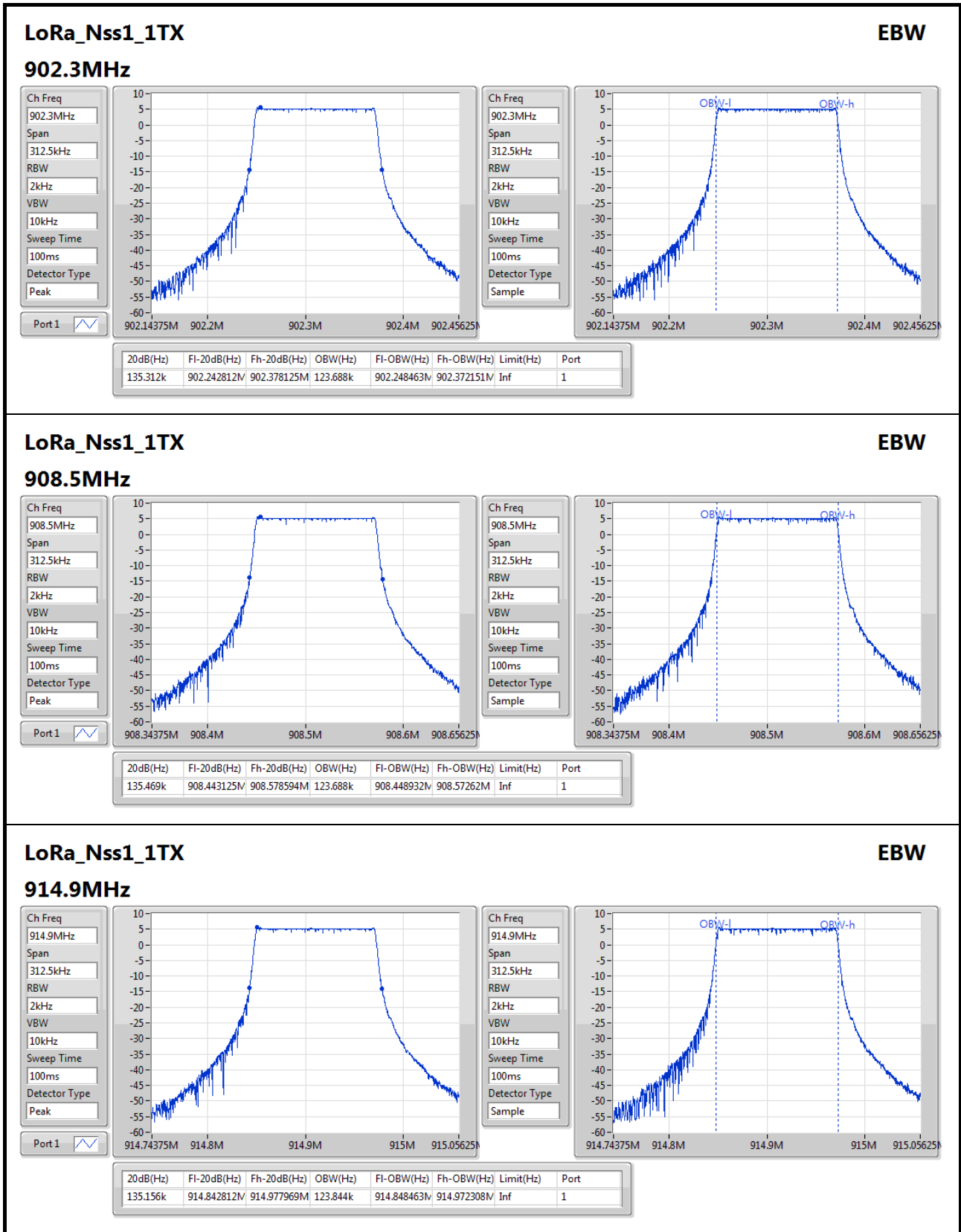
LoRa_Nss1_1TX
EBW

914.9MHz

Ch Freq: 914.9MHz
Span: 312.5kHz
RBW: 2kHz
VBW: 10kHz
Sweep Time: 100ms
Detector Type: Peak

Ch Freq: 914.9MHz
Span: 312.5kHz
RBW: 2kHz
VBW: 10kHz
Sweep Time: 100ms
Detector Type: Sample



Summary

Mode	Max-Space (Hz)	Min-Space (Hz)
LoRa_Nss1_1TX	-	-
902-928MHz	307k	169.5k

Result

Mode	Result	Fl (Hz)	Fh (Hz)	Ch.Space (Hz)	Limit (Hz)
LoRa_Nss1_1TX	-	-	-	-	-
902.3MHz	Pass	902.2515M	902.5145M	263k	135.312k
908.5MHz	Pass	908.4655M	908.7725M	307k	135.469k
914.9MHz	Pass	914.762M	914.9315M	169.5k	135.156k

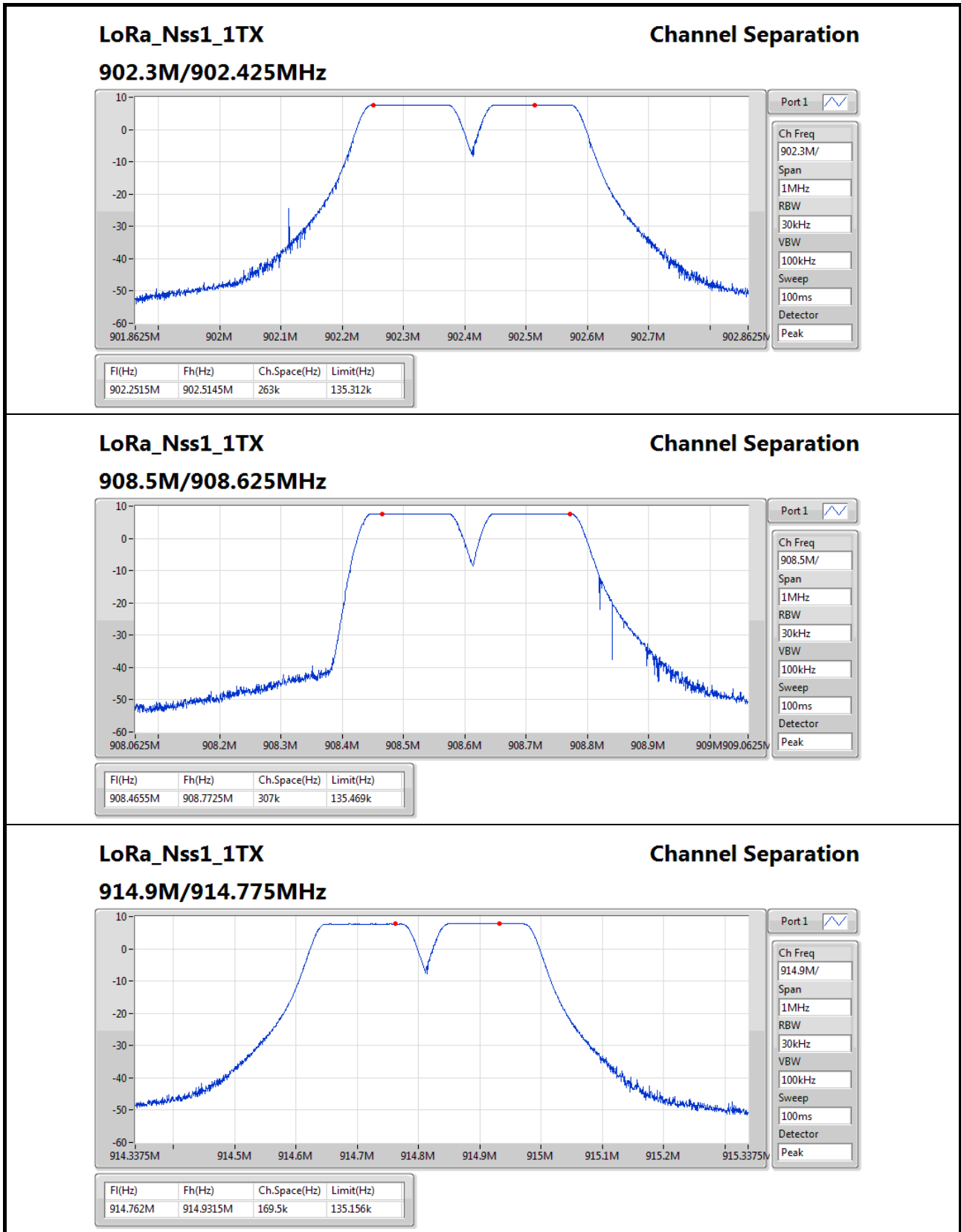



Summary

Mode	Total Power (dBm)	Total Power (W)
LoRa_125KHz	-	-
902-928MHz	18.37	0.06871

Result

Mode	Result	DG (dBi)	Port 1 (dBm)	Total Power (dBm)	Power Limit (dBm)
LoRa_125kHz	-	-	-	-	-
902.3MHz	Pass	1.80	18.32	18.32	30.00
908.5MHz	Pass	1.80	18.34	18.34	30.00
914.9MHz	Pass	1.80	18.37	18.37	30.00

DG = Directional Gain; Port X = Port X output power



Summary

Mode	PD (dBm/RBW)
LoRa_125KHz	-
902-928MHz	4.08

RBW=3kHz.

Result

Mode	Result	DG (dBi)	Port 1 (dBm/RBW)	PD (dBm/RBW)	PD Limit (dBm/RBW)
LoRa_125KHz	-	-	-	-	-
902.3MHz	Pass	1.80	4.08	4.08	8.00
908.5MHz	Pass	1.80	4.03	4.03	8.00
914.9MHz	Pass	1.80	4.01	4.01	8.00

DG = Directional Gain; RBW=3kHz;

PD = trace bin-by-bin of each transmits port summing can be performed maximum power density; **Port X** = Port X power density;

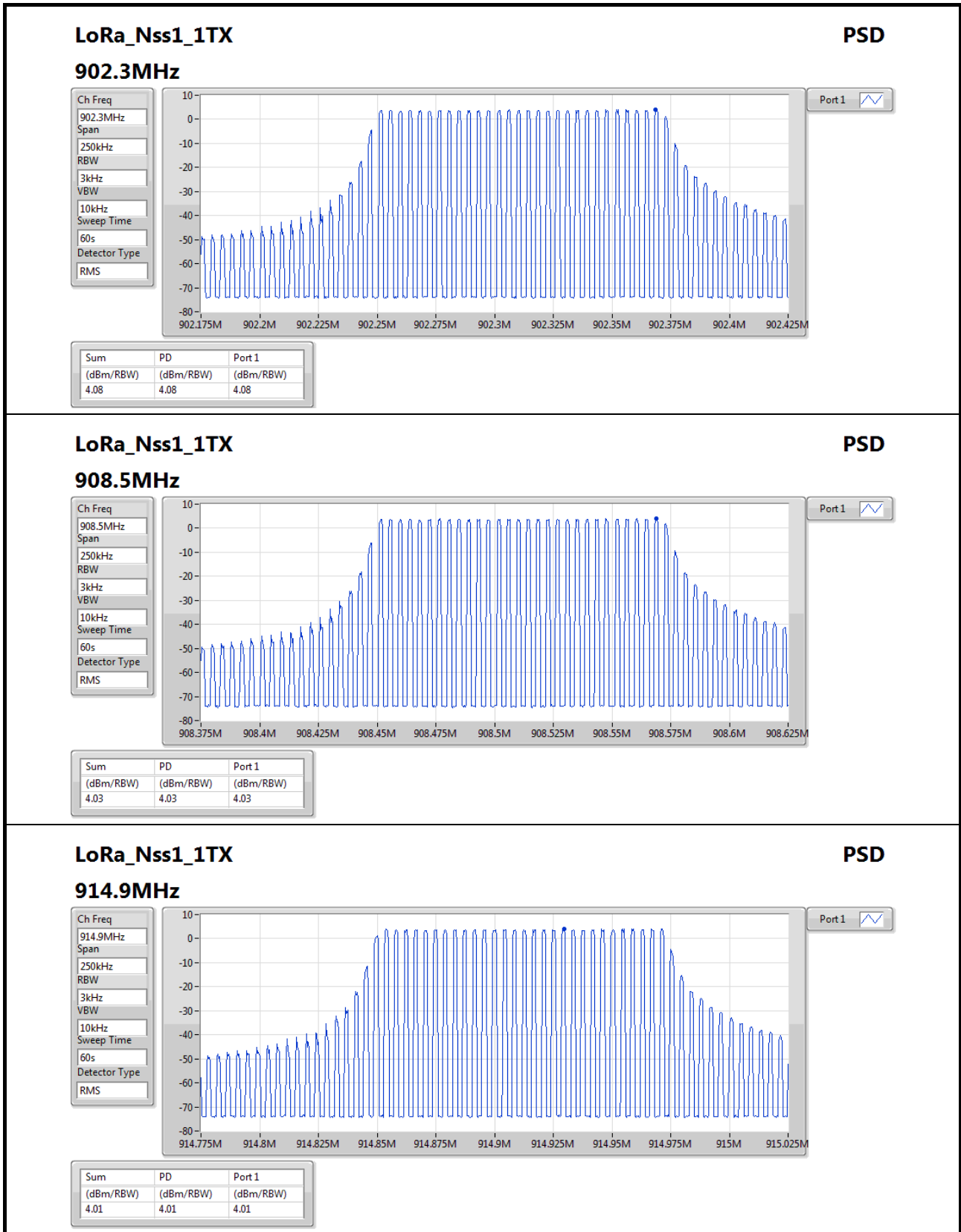



Summary

Mode	Max-Hop No
LoRa_Nss1_1TX	-
902-928MHz	64

Result

Mode	Result	Hopping No	Limit
LoRa_Nss1_1TX	-	-	-
902.3MHz	Pass	64	N/A
908.5MHz	Pass	64	N/A
914.9MHz	Pass	64	N/A

LoRa_Nss1_1TX

902.3MHz

Hopping Ch Bandedge (Non-restricted Band)

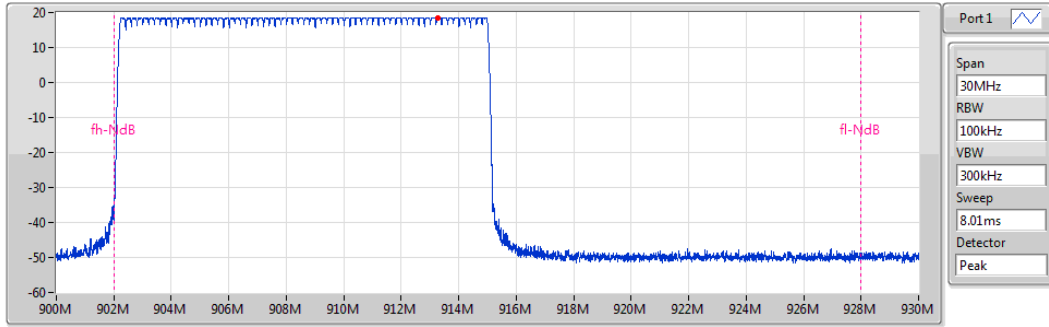

Limit(dBm)	Ref(Hz)	Ref(dBm)	BE-l(Hz)	BE-l(dBm)	BE-h(Hz)	BE-h(dBm)
-20	0	0	913.27125M	18.38	913.27125M	18.38

LoRa_Nss1_1TX

908.5MHz

Hopping Ch Bandedge (Non-restricted Band)

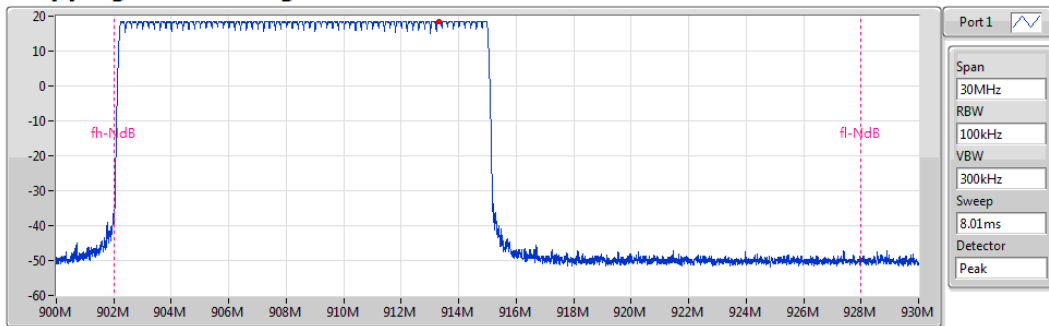

Limit(dBm)	Ref(Hz)	Ref(dBm)	BE-l(Hz)	BE-l(dBm)	BE-h(Hz)	BE-h(dBm)
-20	0	0	913.32375M	18.38	913.32375M	18.38

LoRa_Nss1_1TX

914.9MHz

Hopping Ch Bandedge (Non-restricted Band)

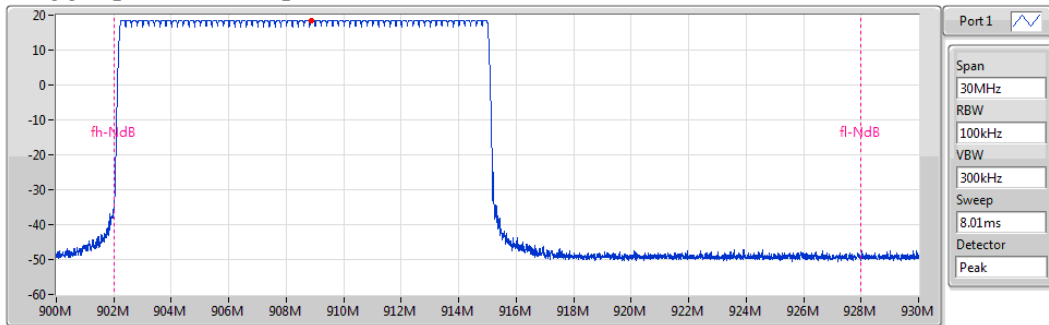

Limit(dBm)	Ref(Hz)	Ref(dBm)	BE-l(Hz)	BE-l(dBm)	BE-h(Hz)	BE-h(dBm)
-20	0	0	908.88M	18.4	908.88M	18.4



Summary

Mode	Max-Dwell (s)
LoRa_Nss1_1TX	-
902-928MHz	372m

Result

Mode	Result	Period (s)	Dwell (s)	Limit (s)	Tx On (s)
LoRa_Nss1_1TX	-	-	-	-	-
902.3MHz	Pass	6	371.25m	0.4	371.25m
908.5MHz	Pass	6	372m	0.4	372m
914.9MHz	Pass	6	372m	0,4	372m

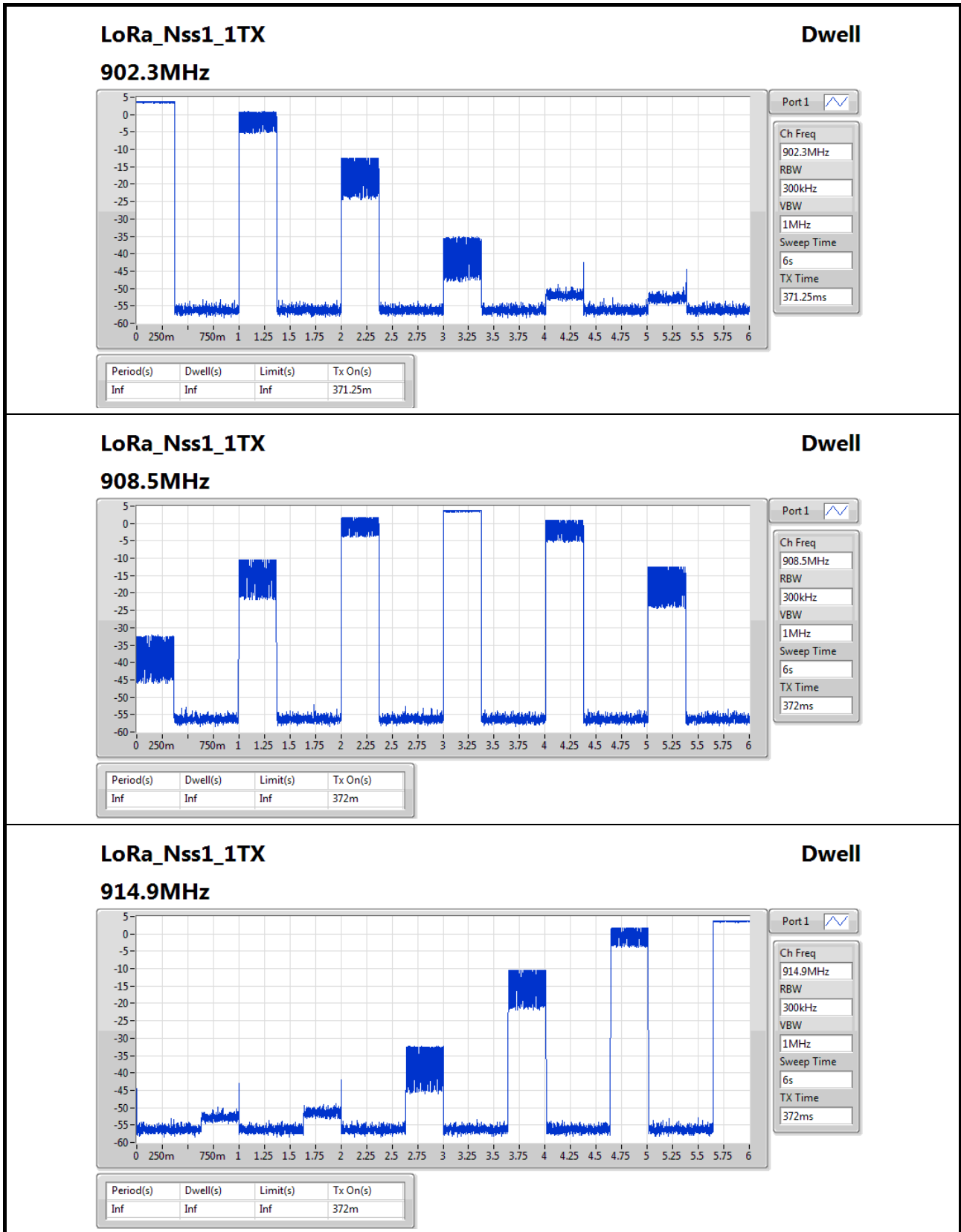



Summary

Mode	Result	Ref (Hz)	Ref (dBm)	Limit (dBm)	Freq (Hz)	Level (dBm)	Freq (Hz)	Level (dBm)	Freq (Hz)	Level (dBm)	Freq (Hz)	Level (dBm)	Port
LoRa_Nss1_1TX	-	-	-	-	-	-	-	-	-	-	-	-	-
902-928MHz	Pass	902.26M	20.86	-9.14	800.627M	-56.54	901.9695M	-31.79	928.108M	-56.54	7.218375G	-32.16	1

Result

Mode	Result	Ref (Hz)	Ref (dBm)	Limit (dBm)	Freq (Hz)	Level (dBm)	Freq (Hz)	Level (dBm)	Freq (Hz)	Level (dBm)	Freq (Hz)	Level (dBm)	Port
LoRa_Nss1_1TX	-	-	-	-	-	-	-	-	-	-	-	-	-
902.3MHz	Pass	902.26M	20.86	-9.14	800.627M	-56.54	901.9695M	-31.79	928.108M	-56.54	7.218375G	-32.16	1
908.5MHz	Pass	908.552M	20.86	-9.14	899.570625M	-55.37	901.961M	-52.51	928.2055M	-56.97	6.992715G	-48.26	1
914.9MHz	Pass	914.844M	20.86	-9.14	858.598375M	-57.05	901.952M	-55.78	928.0045M	-55.31	6.956428G	-47.33	1

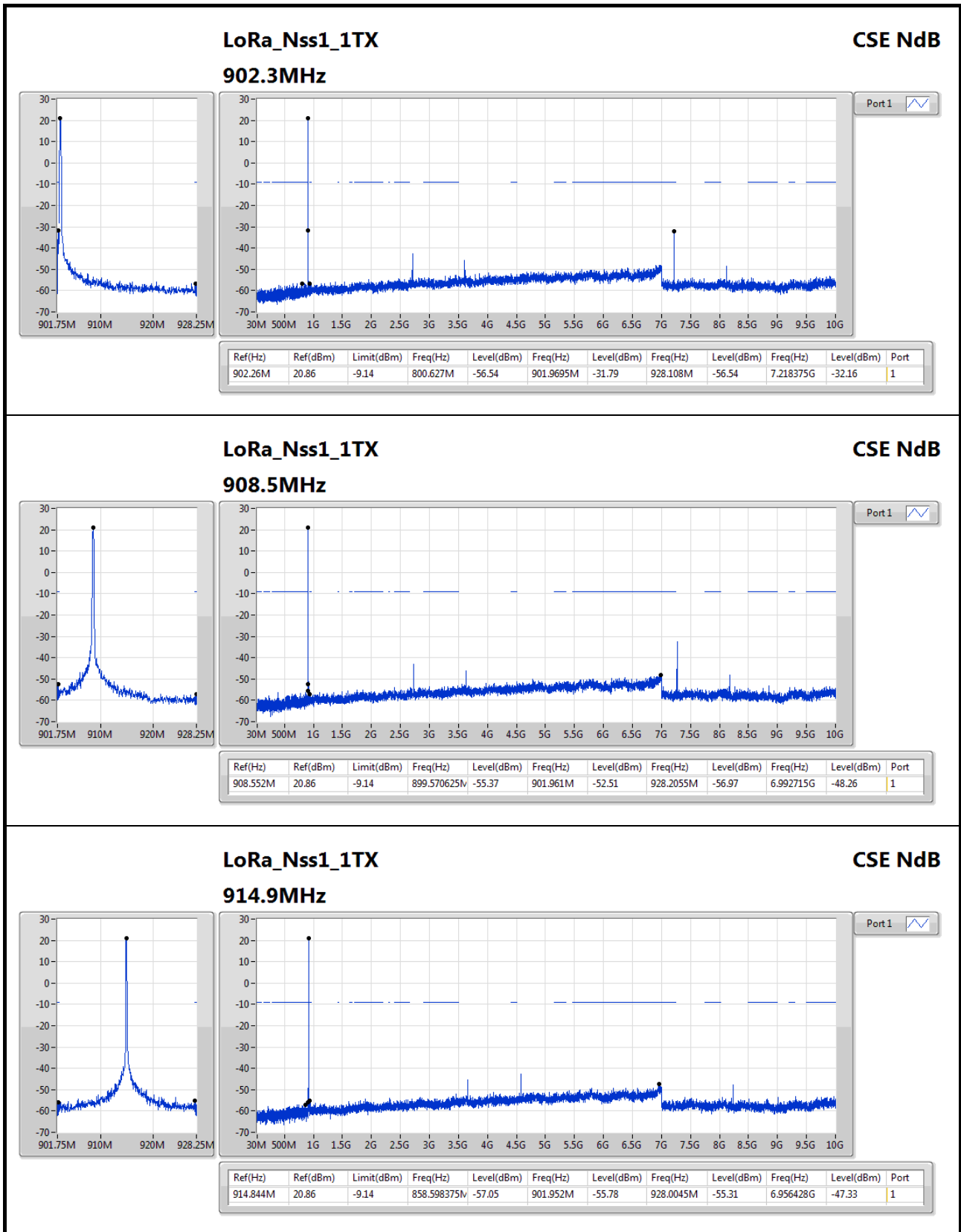



Summary

Mode	Result	Type	Freq (Hz)	Level (dBuV/m)	Limit (dBuV/m)	Margin (dB)	Factor (dB)	Dist (m)	Pol. (H/V)	Azimuth (°)	Height (m)	Comments
LoRa_Nss1_1TX	-	-	-	-	-	-	-	-	-	-	-	-
902-928MHz	Pass	AV	2.7067G	28.07	54.00	-25.93	-1.31	3	H	302	1.66	-

LoRa_Nss1_1TX

902.3MHz_TX

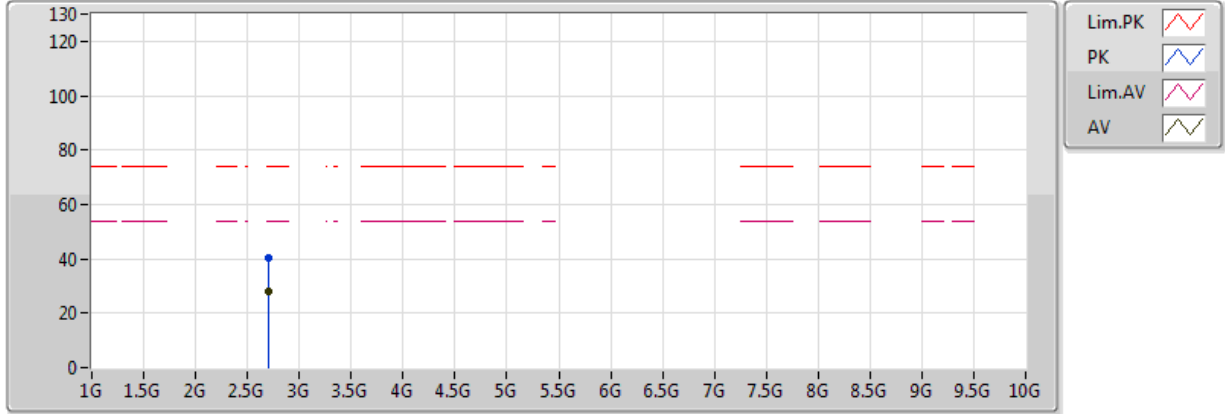

20170414
 EUT_Z_1TX
 Setting 20
 03-P-2
 FSP(100019)

Type	Freq(Hz)	Level(dBuV/m)	Limit(dBuV/m)	Margin(dB)	Factor(dB)	Dist(m)	Pol.(H/V)	Azimuth(°)	Height(m)	Comments
AV	2.70677G	27.85	54.00	-26.15	-1.31	3	V	59	1.76	-
PK	2.70556G	40.38	74.00	-33.62	-1.32	3	V	59	1.76	-

LoRa_Nss1_1TX

902.3MHz_TX

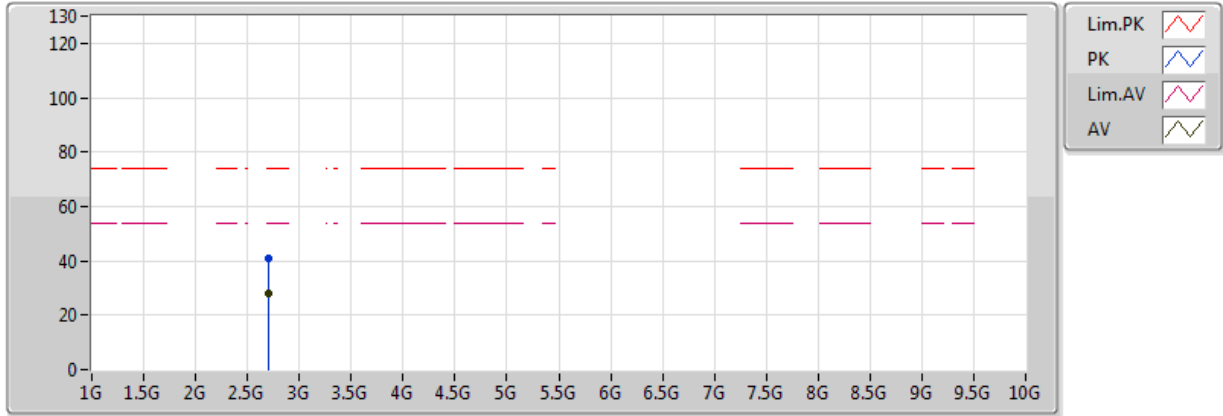

20170414
 EUT_Z_1TX
 Setting 20
 03-P-2
 FSP(100019)

Type	Freq(Hz)	Level(dBuV/m)	Limit(dBuV/m)	Margin(dB)	Factor(dB)	Dist(m)	Pol.(H/V)	Azimuth(°)	Height(m)	Comments
AV	2.7067G	28.07	54.00	-25.93	-1.31	3	H	302	1.66	-
PK	2.70721G	41.00	74.00	-33.00	-1.31	3	H	302	1.66	-

LoRa_Nss1_1TX

908.5MHz_TX

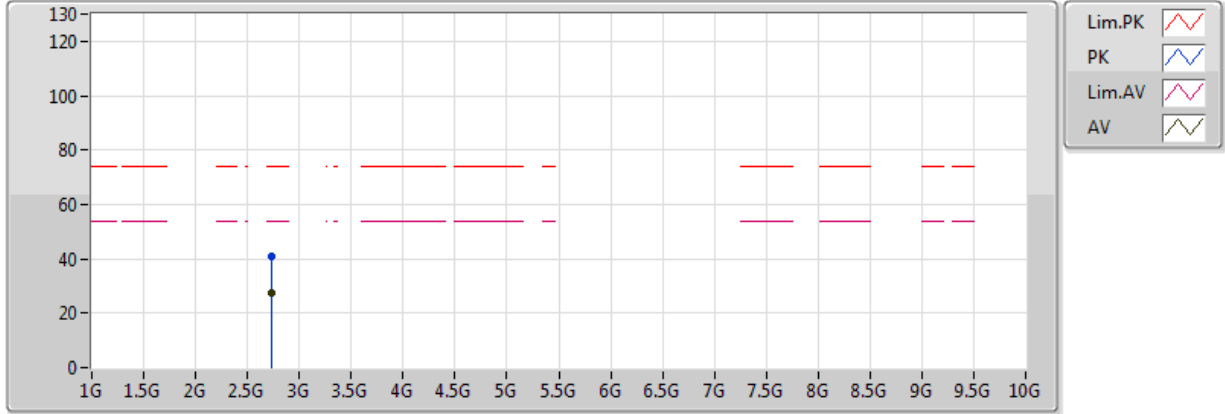

20170414
 EUT_Z_1TX
 Setting 20
 03-P-2
 FSP(100019)

Type	Freq(Hz)	Level(dBuV/m)	Limit(dBuV/m)	Margin(dB)	Factor(dB)	Dist(m)	Pol.(H/V)	Azimuth(°)	Height(m)	Comments
AV	2.7277G	27.35	54.00	-26.65	-1.23	3	V	94	2.43	-
PK	2.72679G	41.10	74.00	-32.90	-1.24	3	V	94	2.43	-

LoRa_Nss1_1TX

908.5MHz_TX

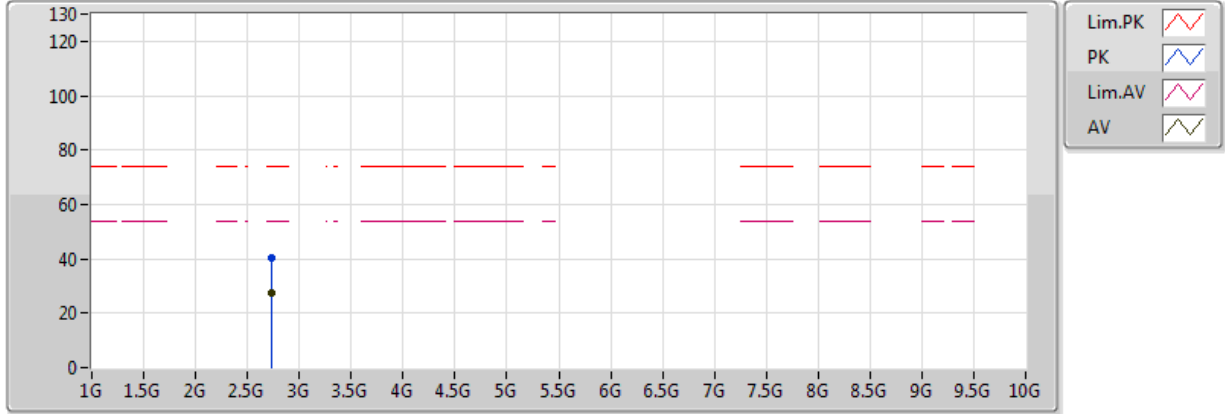

20170414
 EUT_Z_1TX
 Setting 20
 03-P-2
 FSP(100019)

Type	Freq(Hz)	Level(dBuV/m)	Limit(dBuV/m)	Margin(dB)	Factor(dB)	Dist(m)	Pol.(H/V)	Azimuth(°)	Height(m)	Comments
AV	2.72696G	27.45	54.00	-26.55	-1.24	3	H	201	1.56	-
PK	2.72778G	40.61	74.00	-33.39	-1.23	3	H	201	1.56	-

LoRa_Nss1_1TX

914.9MHz_TX

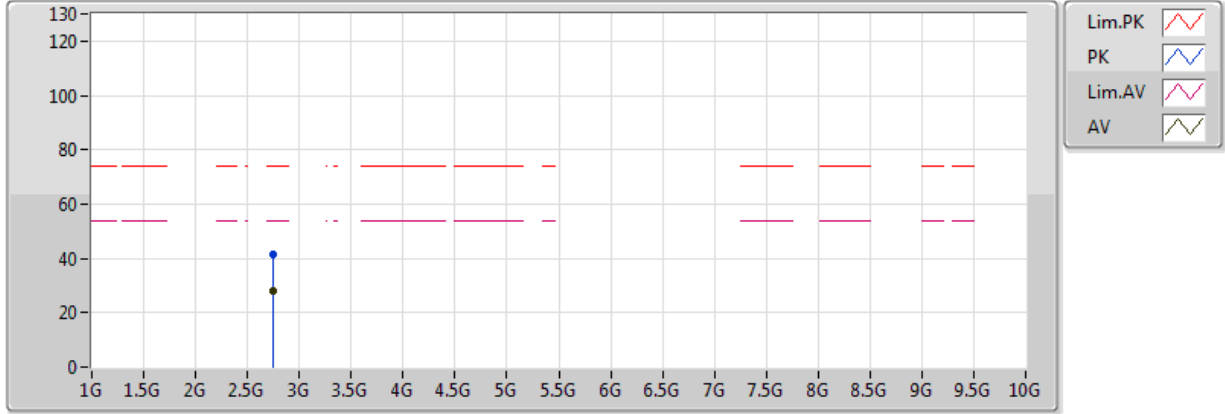

20170414
 EUT_Z_1TX
 Setting 20
 03-P-2
 FSP(100019)

Type	Freq(Hz)	Level(dBuV/m)	Limit(dBuV/m)	Margin(dB)	Factor(dB)	Dist(m)	Pol.(H/V)	Azimuth(°)	Height(m)	Comments
AV	2.74236G	27.86	54.00	-26.14	-1.18	3	V	218	1.33	-
PK	2.74344G	41.42	74.00	-32.58	-1.17	3	V	218	1.33	-

LoRa_Nss1_1TX

914.9MHz_TX

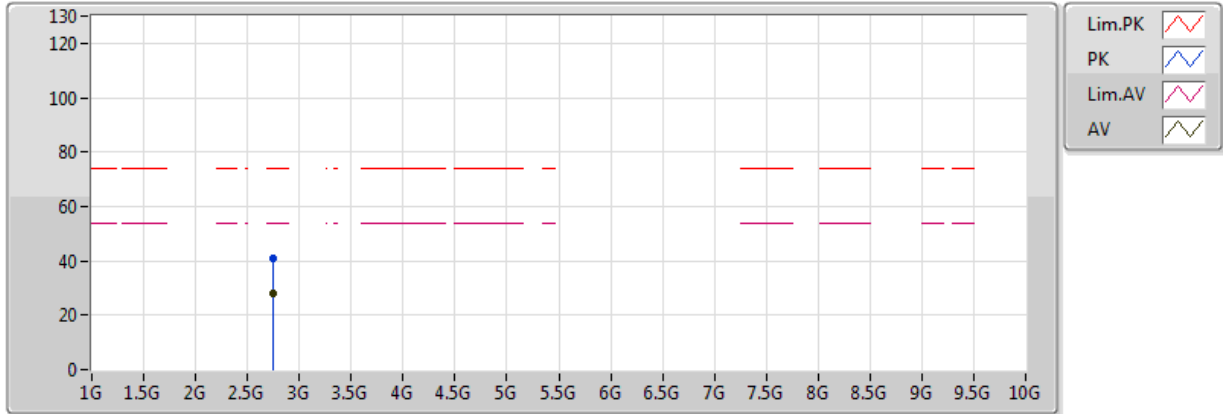

20170414
 EUT_Z_1TX
 Setting 20
 03-P-2
 FSP(100019)

Type	Freq(Hz)	Level(dBuV/m)	Limit(dBuV/m)	Margin(dB)	Factor(dB)	Dist(m)	Pol.(H/V)	Azimuth(°)	Height(m)	Comments
AV	2.74309G	27.93	54.00	-26.07	-1.18	3	H	75	1.57	-
PK	2.74348G	41.17	74.00	-32.83	-1.17	3	H	75	1.57	-