



A D T

FCC TEST REPORT (PART 24)

REPORT NO.: RF140707C54-3
MODEL NO.: UTX-3115XXXXXXXXXXXXXXXXXX,
UTX3115XXXXXXXXXXXXXXXXXX
(“X” can be 0-9 or A-Z or blank or any
alphanumeric character)
FCC ID: M82-UTX-3115
RECEIVED: Jun. 18, 2014
TESTED: Jul. 11 ~ Jul. 22, 2014
ISSUED: Jul. 25, 2014

APPLICANT: ADVANTECH CO., LTD

ADDRESS: No. 1, Alley 20, Lane 26, Rueiguang Rd, Neihu
District, Taipei, Taiwan 114

ISSUED BY: Bureau Veritas Consumer Products Services
(H.K.) Ltd., Taoyuan Branch

LAB ADDRESS: No. 47, 14th Ling, Chia Pau Vil., Lin Kou Dist., New
Taipei City, Taiwan, R.O.C.

TEST LOCATION: No. 19, Hwa Ya 2nd Rd, Wen Hwa Tsuen, Kwei
Shan Hsiang, Taoyuan Hsien 333, Taiwan, R.O.C.

This report should not be used by the client to claim
product certification, approval, or endorsement by TAF or
any government agencies.



This report is for your exclusive use. Any copying or replication of this report to or for any other person or entity, or use of our name or trademark, is permitted only with our prior written permission. This report sets forth our findings solely with respect to the test samples identified herein. The results set forth in this report are not indicative or representative of the quality or characteristics of the lot from which a test sample was taken or any similar or identical product unless specifically and expressly noted. Our report includes all of the tests requested by you and the results thereof based upon the information that you provided to us. You have 60 days from date of issuance of this report to notify us of any material error or omission caused by our negligence, provided, however, that such notice shall be in writing and shall specifically address the issue you wish to raise. A failure to raise such issue within the prescribed time shall constitute your unqualified acceptance of the completeness of this report, the tests conducted and the correctness of the report contents. Unless specific mention, the uncertainty of measurement has been explicitly taken into account to declare the compliance or non-compliance to the specification.

TABLE OF CONTENTS

RELEASE CONTROL RECORD.....	4
1 CERTIFICATION.....	5
2 SUMMARY OF TEST RESULTS	6
2.1 MEASUREMENT UNCERTAINTY	6
2.2 TEST SITE AND INSTRUMENTS.....	7
3 GENERAL INFORMATION	8
3.1 GENERAL DESCRIPTION OF EUT	8
3.2 CONFIGURATION OF SYSTEM UNDER TEST	10
3.3 DESCRIPTION OF SUPPORT UNITS	10
3.4 TEST ITEM AND TEST CONFIGURATION.....	11
3.5 EUT OPERATING CONDITIONS	12
3.6 GENERAL DESCRIPTION OF APPLIED STANDARDS	12
4 TEST TYPES AND RESULTS	13
4.1 OUTPUT POWER MEASUREMENT.....	13
4.1.1 LIMITS OF OUTPUT POWER MEASUREMENT	13
4.1.2 TEST PROCEDURES.....	13
4.1.3 TEST SETUP	14
4.1.4 TEST RESULTS.....	15
4.2 FREQUENCY STABILITY MEASUREMENT.....	19
4.2.1 LIMITS OF FREQUENCY STABILITY MEASUREMENT	19
4.2.2 TEST PROCEDURE	19
4.2.3 TEST SETUP	19
4.2.4 TEST RESULTS.....	20
4.3 OCCUPIED BANDWIDTH MEASUREMENT	21
4.3.1 TEST PROCEDURES.....	21
4.3.2 TEST SETUP	21
4.3.3 TEST RESULTS.....	22
4.4 BAND EDGE MEASUREMENT	23
4.4.1 LIMITS OF BAND EDGE MEASUREMENT	23
4.4.2 TEST SETUP	23
4.4.3 TEST PROCEDURES.....	23
4.4.4 TEST RESULTS.....	24
4.5 CONDUCTED SPURIOUS EMISSIONS	26
4.5.1 LIMITS OF CONDUCTED SPURIOUS EMISSIONS MEASUREMENT	26
4.5.2 TEST PROCEDURE	26
4.5.3 TEST SETUP	26
4.5.4 TEST RESULTS.....	27
4.6 RADIATED EMISSION MEASUREMENT	42
4.6.1 LIMITS OF RADIATED EMISSION MEASUREMENT.....	42



4.6.2	TEST PROCEDURES.....	42
4.6.3	DEVIATION FROM TEST STANDARD.....	42
4.6.4	TEST SETUP	43
4.6.5	TEST RESULTS.....	44
5	PHOTOGRAPHS OF THE TEST CONFIGURATION.....	56
6	INFORMATION ON THE TESTING LABORATORIES	57
7	APPENDIX A – MODIFICATIONS RECORDERS FOR ENGINEERING CHANGES TO THE EUT BY THE LAB	58



A D T

RELEASE CONTROL RECORD

ISSUE NO.	REASON FOR CHANGE	DATE ISSUED
RF140707C54-3	Original release	Jul. 25, 2014



1 CERTIFICATION

PRODUCT: COMPUTER

MODEL: UTX-3115XXXXXXXXXXXXXXXXXX,
UTX3115XXXXXXXXXXXXXXXXXX ("X" can be 0-9 or A-Z or
blank or any alphanumeric character)

BRAND: Advantech

APPLICANT: ADVANTECH CO., LTD

TESTED: Jul. 11 ~ Jul. 22, 2014

TEST SAMPLE: ENGINEERING SAMPLE

STANDARDS: FCC Part 24, Subpart E

The above equipment (model: UTX-3115) has been tested by **Bureau Veritas Consumer Products Services (H.K.) Ltd., Taoyuan Branch**, and found compliance with the requirement of the above standards. The test record, data evaluation & Equipment Under Test (EUT) configurations represented herein are true and accurate accounts of the measurements of the sample's EMC characteristics under the conditions specified in this report.

PREPARED BY : Celine Chou , **DATE** : Jul. 25, 2014
Celine Chou / Specialist

APPROVED BY : Jeremy Lin , **DATE** : Jul. 25, 2014
Jeremy Lin / Project Engineer

2 SUMMARY OF TEST RESULTS

The EUT has been tested according to the following specifications:

APPLIED STANDARD: FCC Part 24 & Part 2			
STANDARD SECTION	TEST TYPE	RESULT	REMARK
2.1046 24.232	Equivalent isotropically radiated power	PASS	Meet the requirement of limit.
2.1055 24.235	Frequency Stability	PASS	Meet the requirement of limit.
2.1049 24.238(b)	Occupied Bandwidth	PASS	Meet the requirement of limit.
24.238(b)	Band Edge Measurements	PASS	Meet the requirement of limit.
2.1051 24.238	Conducted Spurious Emissions	PASS	Meet the requirement of limit.
2.1053 24.238	Radiated Spurious Emissions	PASS	Meet the requirement of limit. Minimum passing margin is -25.54dB at 5557.20MHz.

2.1 MEASUREMENT UNCERTAINTY

Where relevant, the following measurement uncertainty levels have been estimated for tests performed on the EUT as specified in CISPR 16-4-2:

MEASUREMENT	FREQUENCY	UNCERTAINTY
Conducted emissions	150kHz~30MHz	2.44 dB
Radiated emissions	30MHz ~ 200MHz	3.34 dB
	200MHz ~1000MHz	3.35 dB
	1GHz ~ 18GHz	2.26 dB
	18GHz ~ 40GHz	1.94 dB

This uncertainty represents an expanded uncertainty expressed at approximately the 95% confidence level using a coverage factor of k=2.



2.2 TEST SITE AND INSTRUMENTS

DESCRIPTION & MANUFACTURER	MODEL NO.	SERIAL NO.	DATE OF CALIBRATION	DUE DATE OF CALIBRATION
Test Receiver ROHDE & SCHWARZ	ESIB7	100187	Jan. 02, 2014	Jan. 01, 2015
Spectrum Analyzer ROHDE & SCHWARZ	FSP40	100039	Mar. 03, 2014	Mar. 02, 2015
BILOG Antenna SCHWARZBECK	VULB9168	9168-160	Feb. 26, 2014	Feb. 25, 2015
HORN Antenna SCHWARZBECK	9120D	209	Sep. 12, 2013	Sep. 11, 2014
HORN Antenna SCHWARZBECK	BBHA 9170	BBHA9170241	Feb. 17, 2014	Feb. 16, 2015
Preamplifier Agilent	8447D	2944A10633	Oct. 07, 2013	Oct. 06, 2014
Preamplifier Agilent	8449B	3008A01964	Aug. 26, 2013	Aug. 25, 2014
RF signal cable HUBER+SUHNNER	SUCOFLEX 104	214378/4	Aug. 26, 2013	Aug. 25, 2014
RF signal cable HUBER+SUHNNER	SUCOFLEX 106	12738/6 +309224/4	Aug. 26, 2013	Aug. 25, 2014
Software BV ADT	ADT_Radiated_ V7.6.15.9.4	NA	NA	NA
Antenna Tower inn-co GmbH	MA 4000	013303	NA	NA
Antenna Tower Controller inn-co GmbH	CO2000	017303	NA	NA
Turn Table BV ADT	TT100	TT93021703	NA	NA
Turn Table Controller BV ADT	SC100	SC93021703	NA	NA
Mini-Circuits Power Splitter	ZN2PD-9G	NA	Sep. 09, 2013	Sep. 08, 2014
JFW 20dB attenuation	50HF-020-SMA	NA	NA	NA

NOTE: 1. The calibration interval of the above test instruments is 12 months and the calibrations are traceable to NML/ROC and NIST/USA.

2. The test was performed in HwaYa Chamber 3.

3. The horn antenna and HP preamplifier (model: 8449B) are used only for the measurement of emission frequency above 1GHz if tested.

4. The FCC Site Registration No. is 988962.

5. The IC Site Registration No. is IC 7450F-3.



3 GENERAL INFORMATION

3.1 GENERAL DESCRIPTION OF EUT

EUT	COMPUTER
MODEL NO.	UTX-3115XXXXXXXXXXXXXXXXXX, UTX3115XXXXXXXXXXXXXXXXXX ("X" can be 0-9 or A-Z or blank or any alphanumeric character)
POWER SUPPLY	12Vdc from Adapter
MODULATION TYPE	GPRS: GMSK EDGE: 8PSK WCDMA: BPSK, QPSK HSPDA: BPSK HUPDA: QPSK
FREQUENCY RANGE	GPRS, EDGE: 1850.2MHz ~ 1909.8MHz WCDMA: 1852.4MHz ~ 1907.6MHz
MAX. EIRP POWER	GPRS: 663.743 mW (28.22dBm) EDGE: 588.844 mW (27.70dBm) WCDMA: 127.644mW (21.06dBm)
ANTENNA TYPE	Dipole antenna with -0.4dBi gain
ANTENNC CONNECTOR	SMA(M)
I/O PORTS	Refer to users' manual
DATA CABLE	N/A
ACCESSORY DEVICES	Refer to note

NOTE:

1. All models are listed as below.

Brand	Model	Difference
ADVANTECH	UTX-3115XXXXXXXXXXXXXXXXXX	"X" can be 0-9 or A-Z or blank or any alphanumeric character
	UTX3115XXXXXXXXXXXXXXXXXX	

* Model UTX-3115 was chosen for final test.



A D T

2. The EUT uses the following components.

Part	Specification	Vendor	Model
Main board	-	Advantech	AIMB-115
Memory	DDR3L 4GB	Apacer	PC3-1066 CL9
SSD	32GB	Plextor	PX-32G5Le-72
CPU	1.4GHz	Intel	ATOM E3826
3G Module	-	Telit	HE910
Wi-Fi Module	-	Intel	7260HMW
Adapter	I/P: 100-240Vac, 50-60Hz, 1.5A O/P: 12Vdc, 3A DC: 1.5m cable with one core attached on adapter AC: 1.8m shielded cable without core	FSP	FSP036-RAB

3. The above EUT information is declared by manufacturer and for more detailed features description, please refer to the manufacturer's specifications or User's Manual.

3.2 CONFIGURATION OF SYSTEM UNDER TEST

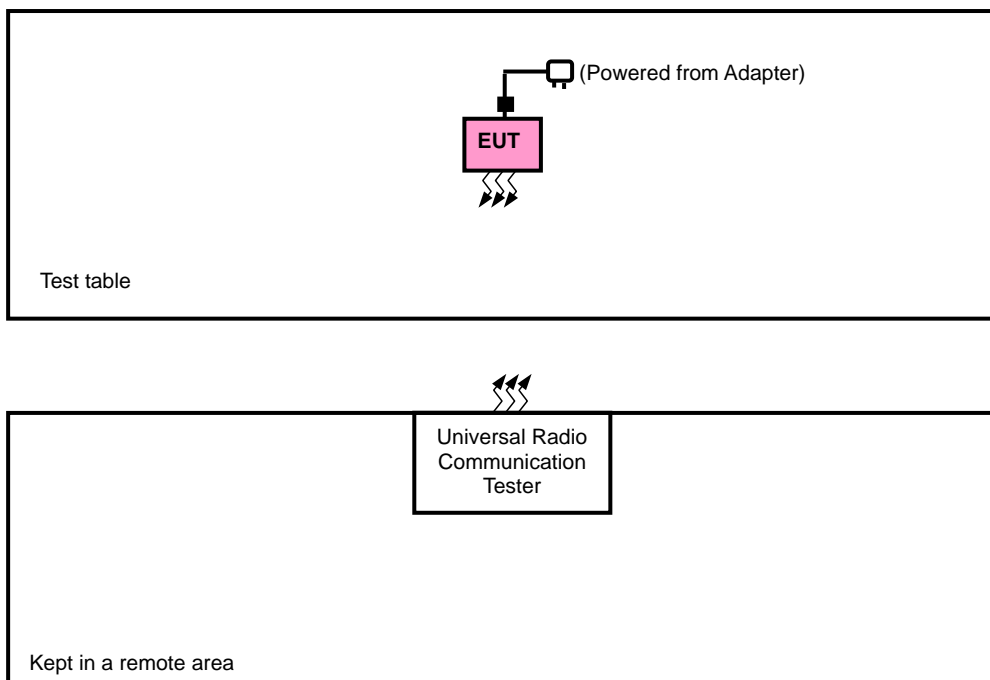

3.3 DESCRIPTION OF SUPPORT UNITS

The EUT has been tested as an independent unit together with other necessary accessories or support units. The following support units or accessories were used to form a representative test configuration during the tests.

NO.	PRODUCT	BRAND	MODEL NO.	SERIAL NO.	FCC ID
1	UNIVERSAL RADIO COMMUNICATION TESTER	R&S	CMU200	123112	NA

NO.	SIGNAL CABLE DESCRIPTION OF THE ABOVE SUPPORT UNITS
1	NA

NOTE:

1. All power cords of the above support units are non shielded (1.8m).
2. Item 1 acted as a communication partner to transfer data.

3.4 TEST ITEM AND TEST CONFIGURATION

Pre-Scan has been conducted to determine the worst-case mode from all possible combinations between available modulations, data rates, XYZ axis and antenna ports. The worst case was found when positioned on Z-plane. Following channel(s) was (were) selected for the final test as listed below:

GPRS MODE

EUT CONFIGURE MODE	TEST ITEM	AVAILABLE CHANNEL	TESTED CHANNEL	MODE
-	EIRP	512 to 810	512, 661, 810	GPRS, EDGE
-	FREQUENCY STABILITY	512 to 810	661	GPRS
-	OCCUPIED BANDWIDTH	512 to 810	512, 661, 810	GPRS, EDGE
-	BAND EDGE	512 to 810	512, 810	GPRS, EDGE
-	CONDCUDED EMISSION	512 to 810	512, 661, 810	GPRS, EDGE
-	RADIATED EMISSION BELOW 1GHz	512 to 810	512	GPRS, EDGE
-	RADIATED EMISSION ABOVE 1GHz	512 to 810	512, 661, 810	GPRS, EDGE

WCDMA MODE

EUT CONFIGURE MODE	TEST ITEM	AVAILABLE CHANNEL	TESTED CHANNEL	MODE
-	ERP	9262 to 9538	9262, 9400, 9538	WCDMA
-	FREQUENCY STABILITY	9262 to 9538	9400	WCDMA
-	OCCUPIED BANDWIDTH	9262 to 9538	9262, 9400, 9538	WCDMA, HSDPA, HSUPA
-	BAND EDGE	9262 to 9538	9262, 9538	WCDMA, HSDPA, HSUPA
-	CONDCUDED EMISSION	9262 to 9538	9262, 9400, 9538	WCDMA, HSDPA, HSUPA
-	RADIATED EMISSION BELOW 1GHz	9262 to 9538	9262	WCDMA
-	RADIATED EMISSION ABOVE 1GHz	9262 to 9538	9262, 9400, 9538	WCDMA

TEST CONDITION:

TEST ITEM	ENVIRONMENTAL CONDITIONS	INPUT POWER	TESTED BY
EIRP	24deg. C, 68%RH	120Vac, 60Hz	Jones Chang
FREQUENCY STABILITY	24deg. C, 64%RH	120Vac, 60Hz	Match Tsui
OCCUPIED BANDWIDTH	24deg. C, 64%RH	120Vac, 60Hz	Match Tsui
BAND EDGE	24deg. C, 64%RH	120Vac, 60Hz	Match Tsui
CONDCUDED EMISSION	24deg. C, 64%RH	120Vac, 60Hz	Match Tsui
RADIATED EMISSION	24deg. C, 68%RH	120Vac, 60Hz	Jones Chang



A D T

3.5 EUT OPERATING CONDITIONS

The EUT makes a call to the communication simulator. The communication simulator station system controlled a EUT to export maximum output power under transmission mode and specific channel frequency

3.6 GENERAL DESCRIPTION OF APPLIED STANDARDS

The EUT is a RF product. According to the specifications of the manufacturer, it must comply with the requirements of the following standards:

FCC 47 CFR Part 2

FCC 47 CFR Part 24

ANSI/TIA/EIA-603-C 2004

NOTE: All test items have been performed and recorded as per the above standards.

4 TEST TYPES AND RESULTS

4.1 OUTPUT POWER MEASUREMENT

4.1.1 LIMITS OF OUTPUT POWER MEASUREMENT

Mobile and portable stations are limited to 2 watts EIRP

4.1.2 TEST PROCEDURES

EIRP MEASUREMENT:

- a. All measurements were done at low, middle and high operational frequency range. RBW and VBW is 1MHz for GSM and 5MHz for WCDMA mode.
- b. Substitution method is used for E.I.R.P measurement. In the semi-anechoic chamber, EUT placed on the 0.8m height of Turn Table, rotated the table around 360 degrees to search the maximum radiation power and receiver antenna shall be rotated vertical and horizontal polarization and moved height from 1m to 4m to find the maximum polar radiated power. The “Read Value” is the spectrum reading the maximum power value.
- c. The substitution horn antenna is substituted for EUT at the same position and signals generator export the CW signal to the substitution antenna via a tx cable. Rotated the Turn Table and moved receiving antenna to find the maximum radiation power. Adjust output power level of S.G to get a Value of spectrum reading equal to “Read Value” of step b. Record the power level of S.G
- d. $EIRP = \text{Output power level of S.G} - \text{TX cable loss} + \text{Antenna gain of substitution horn.}$

CONDUCTED POWER MEASUREMENT:

The EUT was set up for the maximum power with GSM link data modulation and link up with simulator. Set the EUT to transmit under low, middle and high channel and record the power level shown on simulator.

4.1.3 TEST SETUP

EIRP MEASUREMENT:

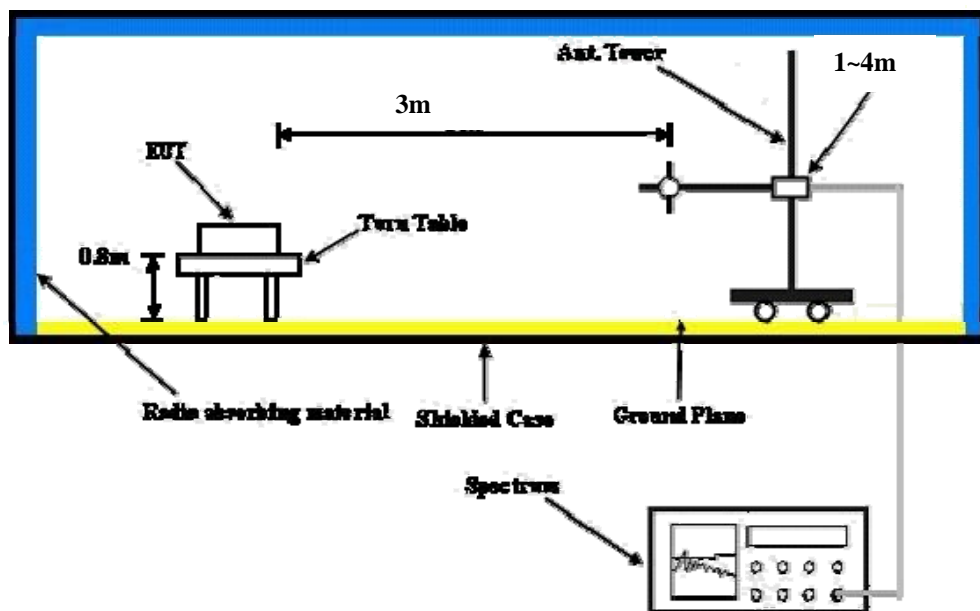

For the actual test configuration, please refer to the attached file (Test Setup Photo).

CONDUCTED POWER MEASUREMENT:

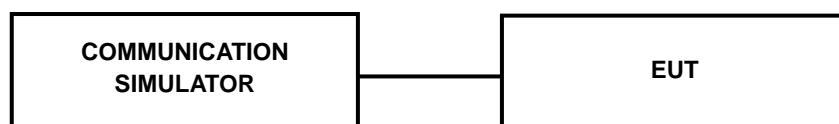

For the actual test configuration, please refer to the attached file (Test Setup Photo).



4.1.4 TEST RESULTS

CONDUCTED OUTPUT POWER (dBm)

Band	GSM1900		
Channel	512	661	810
Frequency (MHz)	1850.2	1880.0	1909.8
GPRS 8	29.94	29.60	29.62
GPRS 10	29.92	29.58	29.60
EDGE 8 (MCS 9)	26.03	25.69	25.71
EDGE 10 (MCS 9)	26.02	25.68	25.70

Band	WCDMA II		
Channel	9262	9400	9538
Frequency (MHz)	1852.4	1880.0	1907.6
RMC 12.2K	22.65	22.54	22.44
HSDPA Subtest-1	20.88	20.77	20.67
HSDPA Subtest-2	20.94	20.83	20.73
HSDPA Subtest-3	20.97	20.86	20.76
HSDPA Subtest-4	20.95	20.84	20.74



A D T

EIRP POWER (dBm)**FOR GPRS MODE:**

MODE		TX channel 512					
ANTENNA POLARITY & TEST DISTANCE: HORIZONTAL AT 3 M							
No.	Freq. (MHz)	Reading (dBm)	S.G Power Value (dBm)	Correction Factor (dB)	EIRP (dBm)	Limit (dBm)	Margin (dB)
1	1850.20	-13.32	22.78	1.07	23.85	33.00	-9.15
ANTENNA POLARITY & TEST DISTANCE: VERTICAL AT 3 M							
No.	Freq. (MHz)	Reading (dBm)	S.G Power Value (dBm)	Correction Factor (dB)	EIRP (dBm)	Limit (dBm)	Margin (dB)
1	1850.20	-8.84	26.13	1.07	27.20	33.00	-5.80

MODE		TX channel 661					
ANTENNA POLARITY & TEST DISTANCE: HORIZONTAL AT 3 M							
No.	Freq. (MHz)	Reading (dBm)	S.G Power Value (dBm)	Correction Factor (dB)	EIRP (dBm)	Limit (dBm)	Margin (dB)
1	1880.00	-12.08	23.42	1.12	24.54	33.00	-8.46
ANTENNA POLARITY & TEST DISTANCE: VERTICAL AT 3 M							
No.	Freq. (MHz)	Reading (dBm)	S.G Power Value (dBm)	Correction Factor (dB)	EIRP (dBm)	Limit (dBm)	Margin (dB)
1	1880.00	-7.60	26.77	1.12	27.89	33.00	-5.11

MODE		TX channel 810					
ANTENNA POLARITY & TEST DISTANCE: HORIZONTAL AT 3 M							
No.	Freq. (MHz)	Reading (dBm)	S.G Power Value (dBm)	Correction Factor (dB)	EIRP (dBm)	Limit (dBm)	Margin (dB)
1	1909.80	-11.68	23.74	1.11	24.85	33.00	-8.15
ANTENNA POLARITY & TEST DISTANCE: VERTICAL AT 3 M							
No.	Freq. (MHz)	Reading (dBm)	S.G Power Value (dBm)	Correction Factor (dB)	EIRP (dBm)	Limit (dBm)	Margin (dB)
1	1909.80	-8.23	27.11	1.11	28.22	33.00	-4.78

NOTE: Power Value (dBm) = S.G Power Value (dBm) + Correction Factor (dB).



FOR EDGE MODE:

MODE		TX channel 512					
ANTENNA POLARITY & TEST DISTANCE: HORIZONTAL AT 3 M							
No.	Freq. (MHz)	Reading (dBm)	S.G Power Value (dBm)	Correction Factor (dB)	EIRP (dBm)	Limit (dBm)	Margin (dB)
1	1850.20	-13.82	22.28	1.07	23.35	33.00	-9.65
ANTENNA POLARITY & TEST DISTANCE: VERTICAL AT 3 M							
No.	Freq. (MHz)	Reading (dBm)	S.G Power Value (dBm)	Correction Factor (dB)	EIRP (dBm)	Limit (dBm)	Margin (dB)
1	1850.20	-9.33	25.64	1.07	26.71	33.00	-6.29

MODE		TX channel 661					
ANTENNA POLARITY & TEST DISTANCE: HORIZONTAL AT 3 M							
No.	Freq. (MHz)	Reading (dBm)	S.G Power Value (dBm)	Correction Factor (dB)	EIRP (dBm)	Limit (dBm)	Margin (dB)
1	1880.00	-12.59	22.91	1.12	24.03	33.00	-8.97
ANTENNA POLARITY & TEST DISTANCE: VERTICAL AT 3 M							
No.	Freq. (MHz)	Reading (dBm)	S.G Power Value (dBm)	Correction Factor (dB)	EIRP (dBm)	Limit (dBm)	Margin (dB)
1	1880.00	-8.11	26.26	1.12	27.38	33.00	-5.62

MODE		TX channel 810					
ANTENNA POLARITY & TEST DISTANCE: HORIZONTAL AT 3 M							
No.	Freq. (MHz)	Reading (dBm)	S.G Power Value (dBm)	Correction Factor (dB)	EIRP (dBm)	Limit (dBm)	Margin (dB)
1	1909.80	-12.18	23.24	1.11	24.35	33.00	-8.65
ANTENNA POLARITY & TEST DISTANCE: VERTICAL AT 3 M							
No.	Freq. (MHz)	Reading (dBm)	S.G Power Value (dBm)	Correction Factor (dB)	EIRP (dBm)	Limit (dBm)	Margin (dB)
1	1909.80	-8.75	26.59	1.11	27.70	33.00	-5.30

NOTE: Power Value (dBm) = S.G Power Value (dBm) + Correction Factor (dB).



A D T

FOR WCDMA MODE:

MODE		TX channel 9262					
ANTENNA POLARITY & TEST DISTANCE: HORIZONTAL AT 3 M							
No.	Freq. (MHz)	Reading (dBm)	S.G Power Value (dBm)	Correction Factor (dB)	EIRP (dBm)	Limit (dBm)	Margin (dB)
1	1852.40	-20.65	15.41	1.07	16.48	33.00	-16.52
ANTENNA POLARITY & TEST DISTANCE: VERTICAL AT 3 M							
No.	Freq. (MHz)	Reading (dBm)	S.G Power Value (dBm)	Correction Factor (dB)	EIRP (dBm)	Limit (dBm)	Margin (dB)
1	1852.40	-16.04	18.89	1.07	19.96	33.00	-13.04

MODE		TX channel 9400					
ANTENNA POLARITY & TEST DISTANCE: HORIZONTAL AT 3 M							
No.	Freq. (MHz)	Reading (dBm)	S.G Power Value (dBm)	Correction Factor (dB)	EIRP (dBm)	Limit (dBm)	Margin (dB)
1	1880.00	-18.58	16.92	1.12	18.04	33.00	-14.96
ANTENNA POLARITY & TEST DISTANCE: VERTICAL AT 3 M							
No.	Freq. (MHz)	Reading (dBm)	S.G Power Value (dBm)	Correction Factor (dB)	EIRP (dBm)	Limit (dBm)	Margin (dB)
1	1880.00	-16.15	18.22	1.12	19.34	33.00	-13.66

MODE		TX channel 9538					
ANTENNA POLARITY & TEST DISTANCE: HORIZONTAL AT 3 M							
No.	Freq. (MHz)	Reading (dBm)	S.G Power Value (dBm)	Correction Factor (dB)	EIRP (dBm)	Limit (dBm)	Margin (dB)
1	1907.60	-19.97	15.46	1.11	16.57	33.00	-16.43
ANTENNA POLARITY & TEST DISTANCE: VERTICAL AT 3 M							
No.	Freq. (MHz)	Reading (dBm)	S.G Power Value (dBm)	Correction Factor (dB)	EIRP (dBm)	Limit (dBm)	Margin (dB)
1	1907.60	-15.32	19.95	1.11	21.06	33.00	-11.94

NOTE: Power Value (dBm) = S.G Power Value (dBm) + Correction Factor (dB).

4.2 FREQUENCY STABILITY MEASUREMENT

4.2.1 LIMITS OF FREQUENCY STABILITY MEASUREMENT

The frequency stability shall be sufficient to ensure that the fundamental emission stays within the authorized frequency block.

4.2.2 TEST PROCEDURE

- a. Device is placed at the oven room. The oven room could control the temperatures and humidity. Power warm up is at least 15 min and power applied should perform before recording frequency error.
- b. EUT is connected the external power supply to control the AC input power. The test voltage range is from minimum to maximum working voltage. Each step shall be record the frequency error rate.
- c. The temperature range step is 10 degrees in this test items. All temperature levels shall be hold the $\pm 0.5^{\circ}\text{C}$ during the measurement testing. The each temperature step shall be at least 0.5 hours, consider the EUT could be test under the stability condition.

NOTE: The frequency error was recorded frequency error from the communication simulator.

4.2.3 TEST SETUP

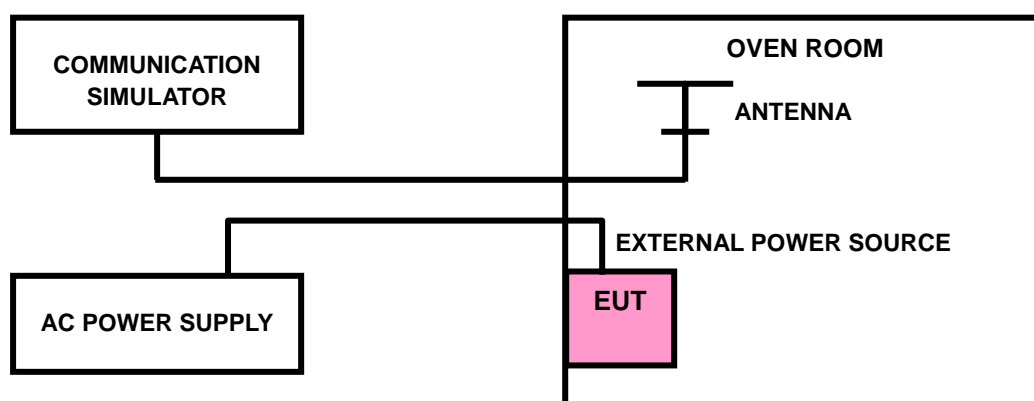

4.2.4 TEST RESULTS

FREQUENCY ERROR vs. VOLTAGE

VOLTAGE (Volts)	FREQUENCY ERROR (ppm)		LIMIT (ppm)
	GPRS	WCDMA	
102	0.008	0.014	2.5
120	0.006	0.011	2.5
138	0.008	0.015	2.5

NOTE: The applicant defined the normal working voltage is from 102Vac to 138Vac.

FREQUENCY ERROR vs. TEMPERATURE.

TEMP. (°C)	FREQUENCY ERROR (ppm)		LIMIT (ppm)
	GPRS	WCDMA	
50	0.013	0.020	2.5
40	0.010	0.018	2.5
30	0.009	0.014	2.5
20	0.006	0.011	2.5
10	0.010	0.011	2.5
0	0.013	0.016	2.5
-10	0.019	0.019	2.5
-20	0.021	0.023	2.5

4.3 OCCUPIED BANDWIDTH MEASUREMENT

4.3.1 TEST PROCEDURES

The EUT makes a call to the communication simulator. All measurements were done at low, middle and high operational frequency range. The communication simulator station system controlled a EUT to export maximum output power under transmission mode and specific channel frequency. Use OBW measurement function of Spectrum analyzer to measure 99 % occupied bandwidth.

4.3.2 TEST SETUP

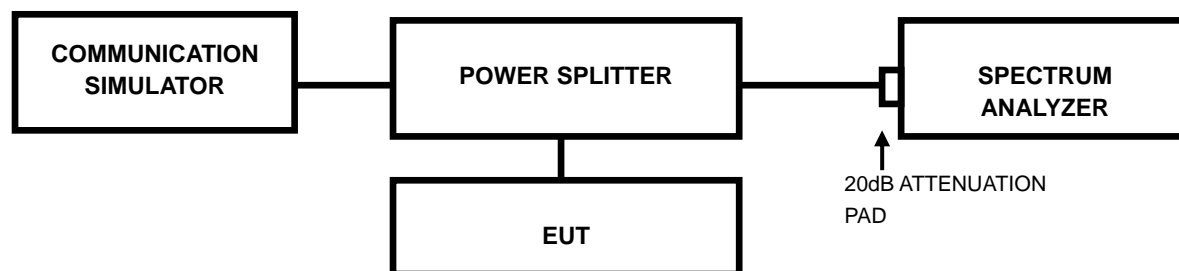

4.3.3 TEST RESULTS

CHANNEL	FREQUENCY (MHz)	99% OCCUPIED BANDWIDTH (kHz)		CHANNEL	FREQ. (MHz)	99% OCCUPIED BANDWIDTH (MHz)		
		GPRS	EDGE			WCDMA	HSDPA	HSUPA
512	1850.2	255.00	255.00	9262	1852.4	4.12	4.10	4.15
661	1880.0	255.00	255.00	9400	1880.0	4.08	4.08	4.08
810	1909.8	255.00	255.00	9538	1907.6	4.12	4.10	4.12

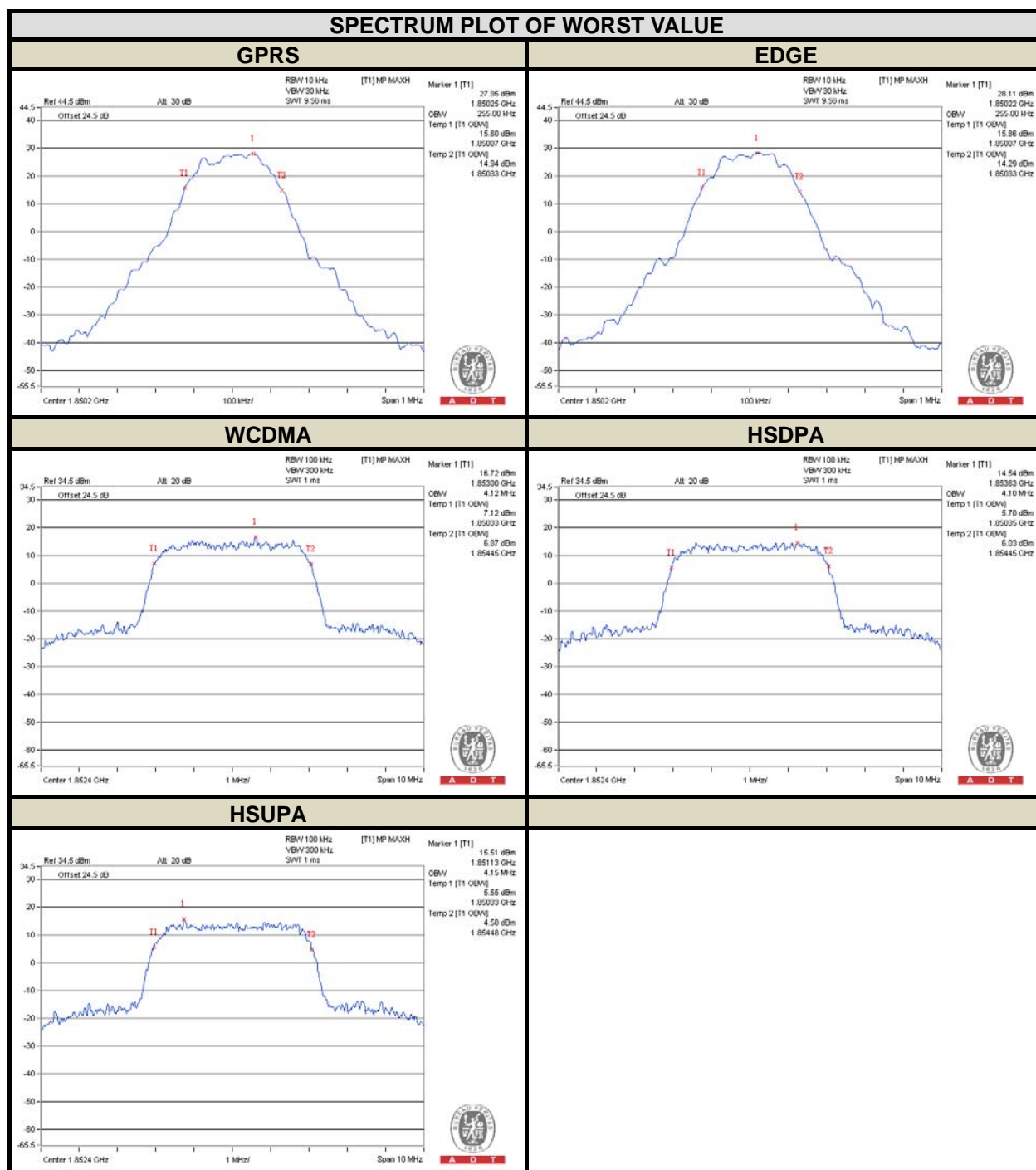

4.4 BAND EDGE MEASUREMENT

4.4.1 LIMITS OF BAND EDGE MEASUREMENT

Power of any emission outside of the authorized operating frequency ranges must be attenuated below the transmitting power (P) by a factor of at least $43 + 10 \log(P)$ dB. In the 1 MHz bands immediately outside and adjacent to the frequency block a resolution bandwidth of at least one percent of the emission bandwidth of the fundamental emission of the transmitter may be employed.

4.4.2 TEST SETUP

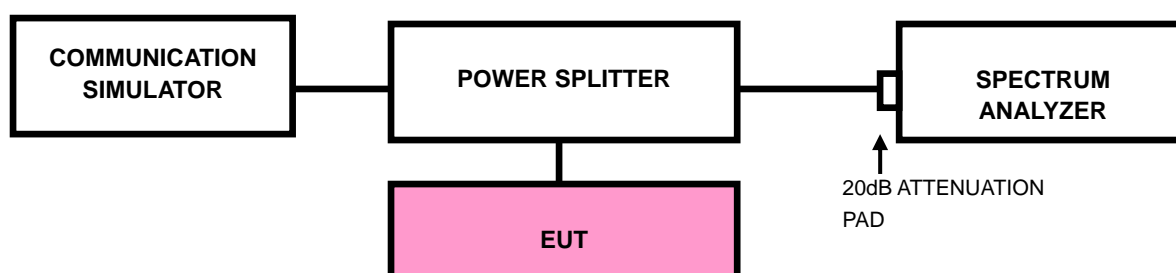

4.4.3 TEST PROCEDURES

- a. All measurements were done at low and high operational frequency range.
- b. The center frequency of spectrum is the band edge frequency and span is 1.5 MHz. RB of the spectrum is 3kHz and VB of the spectrum is 10kHz (GSM).
- c. The center frequency of spectrum is the band edge frequency and span is 10MHz. RB of the spectrum is 100kHz and VB of the spectrum is 300kHz (WCDMA/HSDPA/HSUPA).
- d. Record the max trace plot into the test report.



A D T

4.4.4 TEST RESULTS

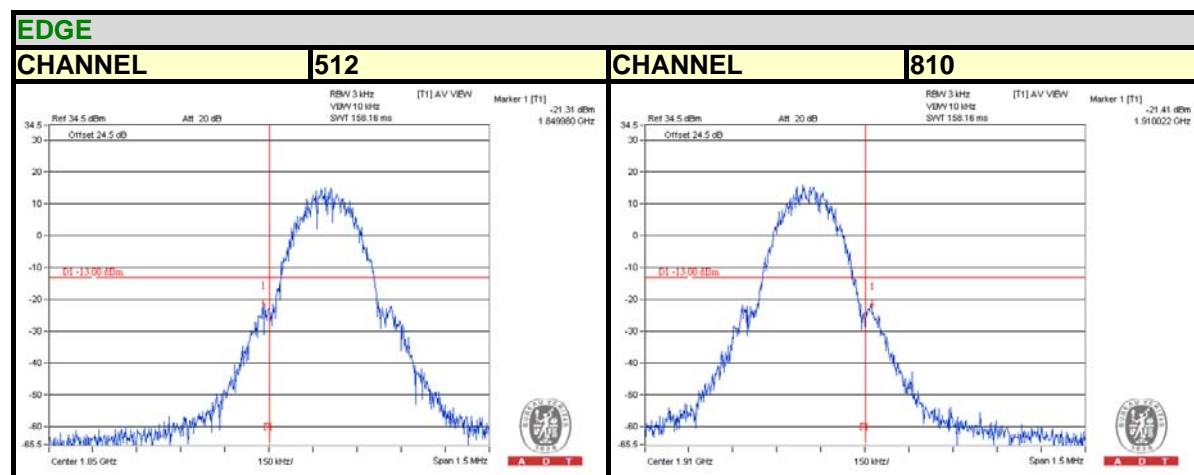
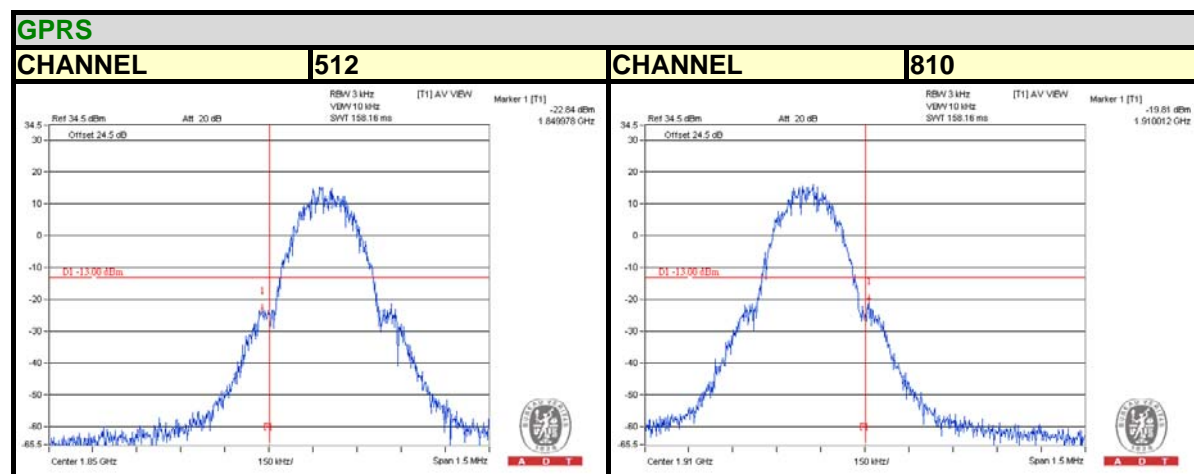



A D T

WCDMA

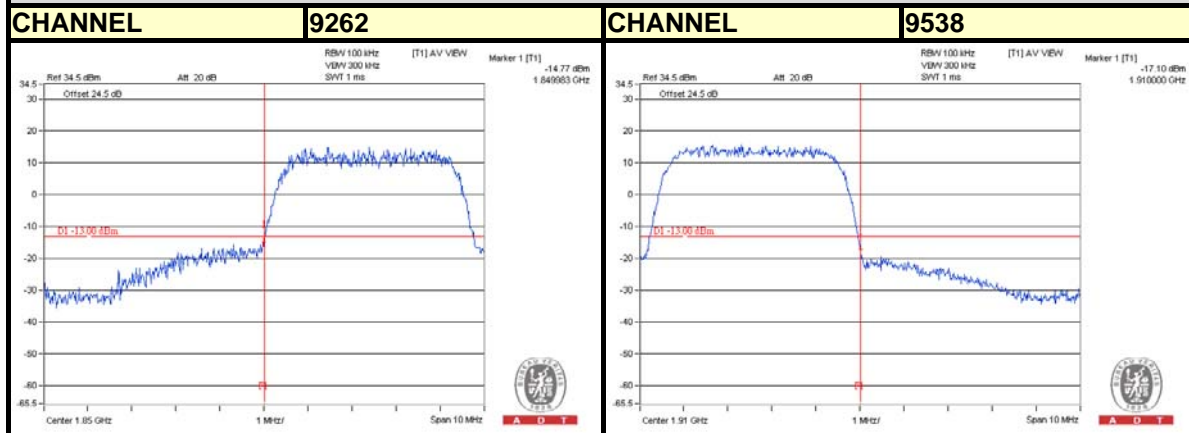

HSDPA

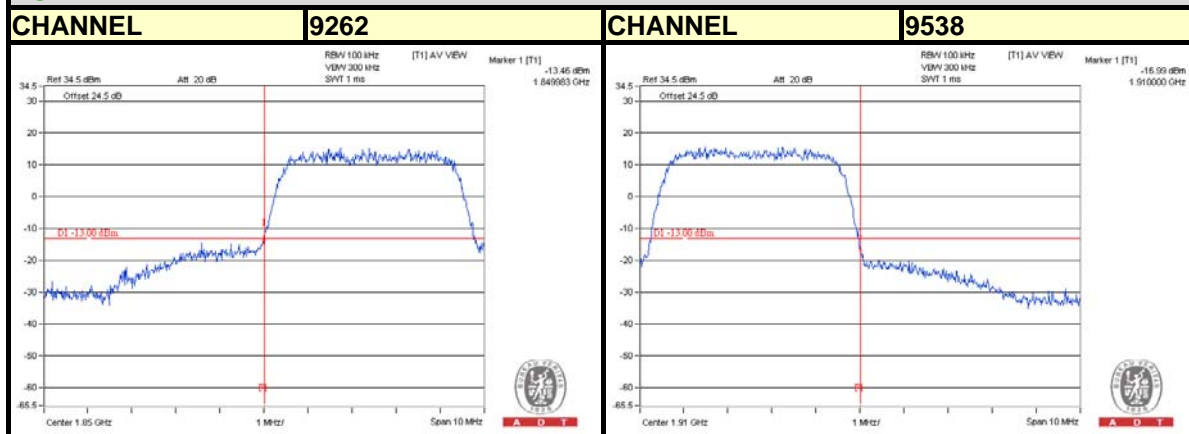

HSUPA

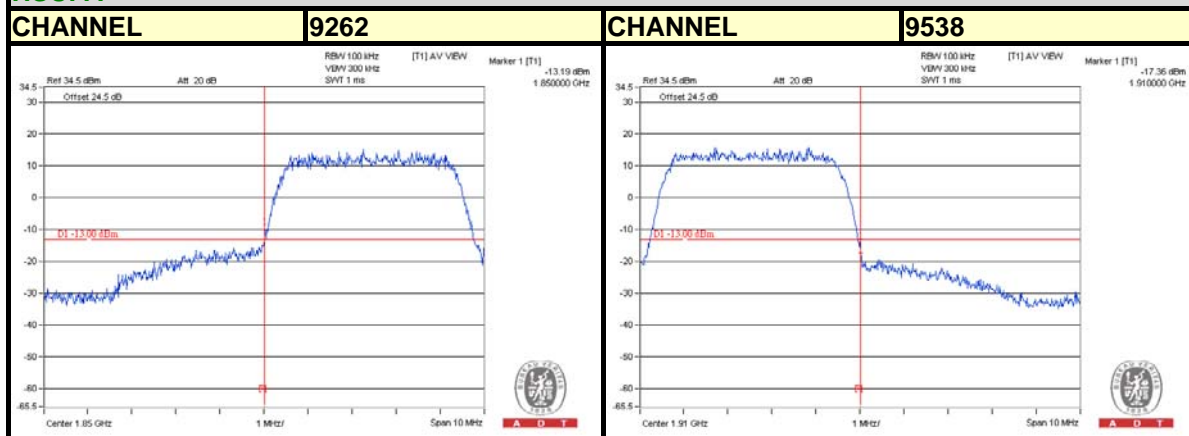

4.5 CONDUCTED SPURIOUS EMISSIONS

4.5.1 LIMITS OF CONDUCTED SPURIOUS EMISSIONS MEASUREMENT

The power of any emission outside of the authorized operating frequency ranges must be attenuated below the transmitting power (P) by a factor of at least $43 + 10 \log(P)$ dB. The emission limit equal to -13dBm .

4.5.2 TEST PROCEDURE

- a. The EUT makes a phone call to the communication simulator. All measurements were done at low, middle and high operational frequency range.
- b. Measuring frequency range is from 9 kHz to 20GHz. 20dB attenuation pad is connected with spectrum. RBW=1MHz and VBW=3MHz is used for conducted emission measurement.

4.5.3 TEST SETUP

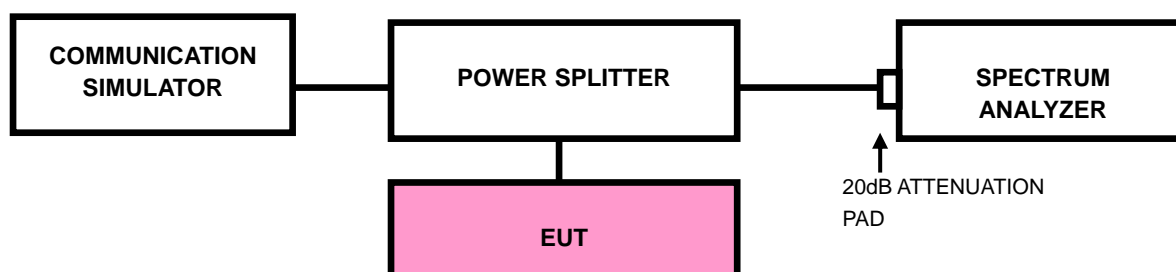



A D T

4.5.4 TEST RESULTS

GPRS

CHANNEL 512

FREQUENCY RANGE : 9kHz~3GHz

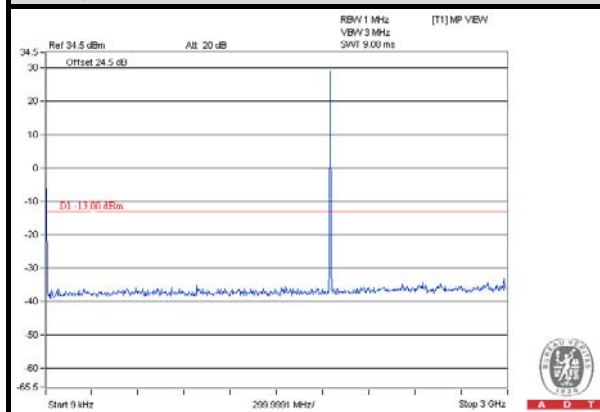

FREQUENCY RANGE : 3GHz~10GHz

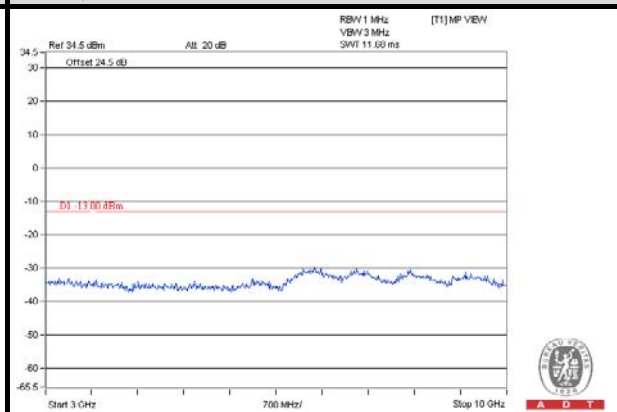

FREQUENCY RANGE : 10GHz~20GHz

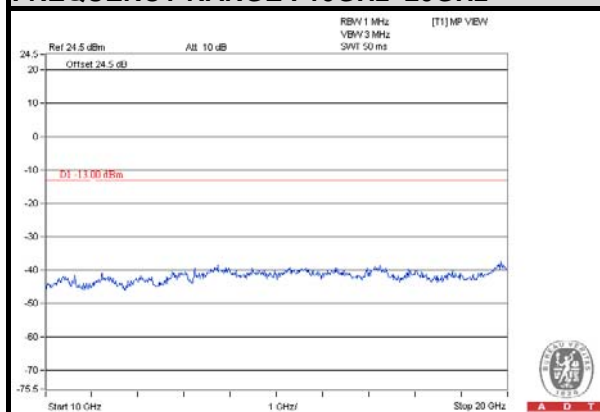



A D T

GPRS

CHANNEL 661

FREQUENCY RANGE : 9kHz~3GHz

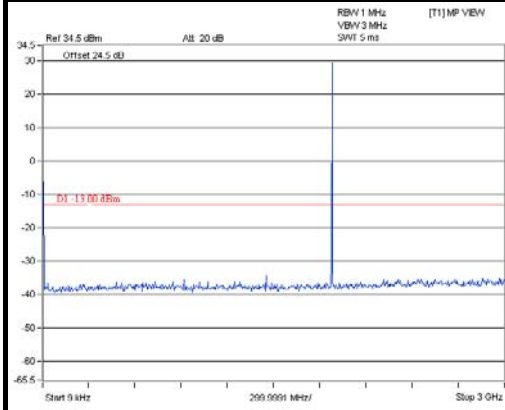

FREQUENCY RANGE : 3GHz~10GHz

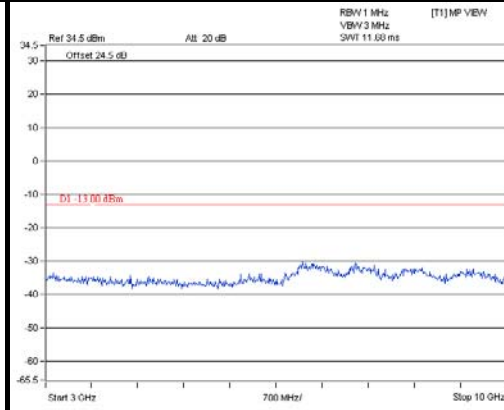

FREQUENCY RANGE : 10GHz~20GHz

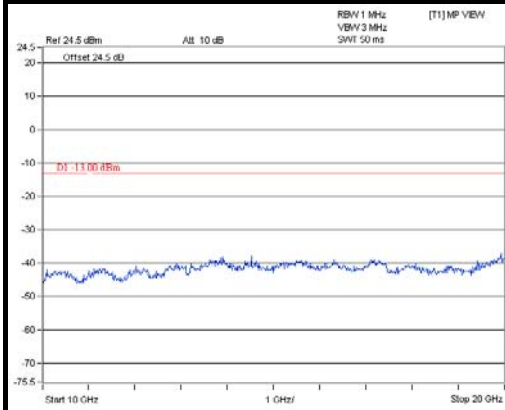



A D T

GPRS

CHANNEL 810

FREQUENCY RANGE : 9kHz~3GHz

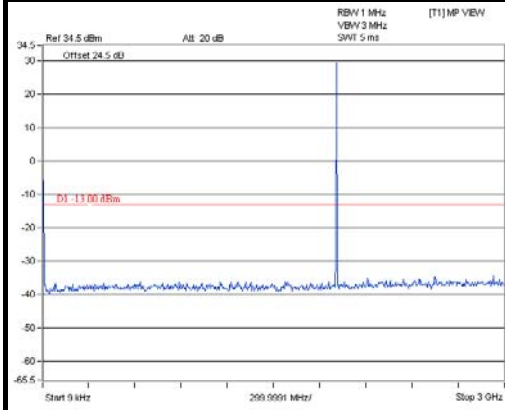

FREQUENCY RANGE : 3GHz~10GHz

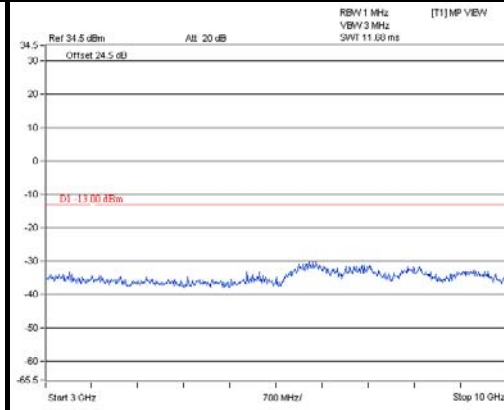

FREQUENCY RANGE : 10GHz~20GHz

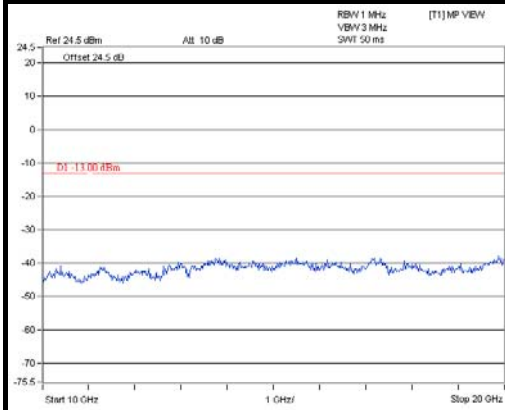



A D T

EDGE

CHANNEL 512

FREQUENCY RANGE : 9kHz~3GHz

FREQUENCY RANGE : 3GHz~10GHz

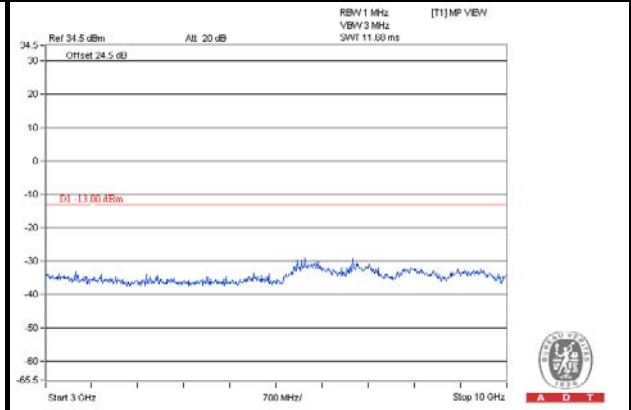
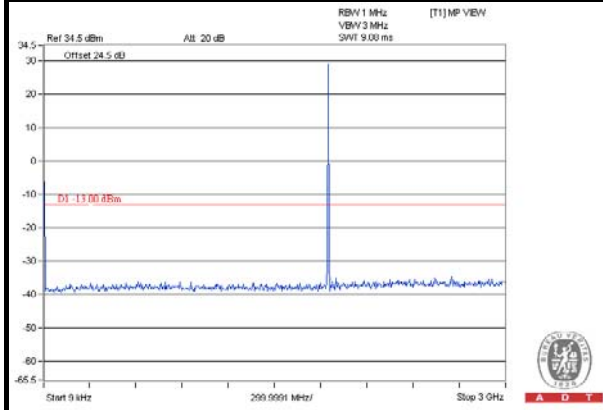

FREQUENCY RANGE : 10GHz~20GHz

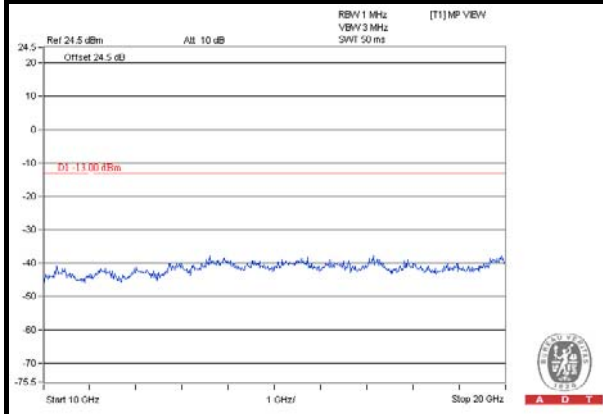



A D T

EDGE

CHANNEL 661

FREQUENCY RANGE : 9kHz~3GHz

FREQUENCY RANGE : 3GHz~10GHz

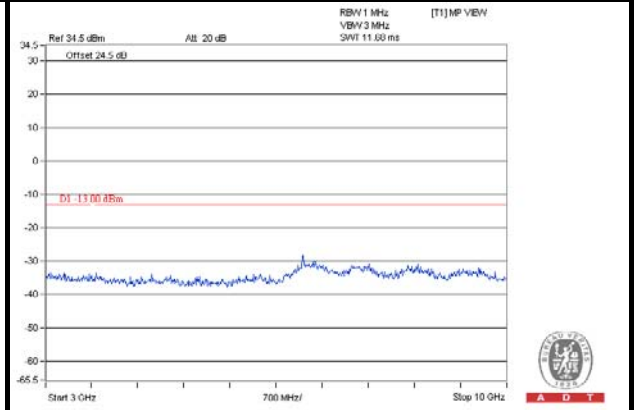
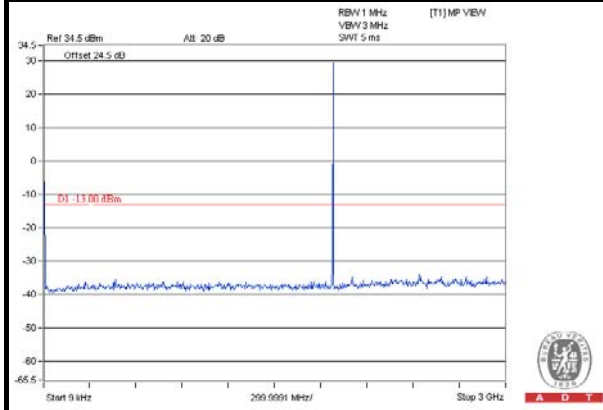

FREQUENCY RANGE : 10GHz~20GHz

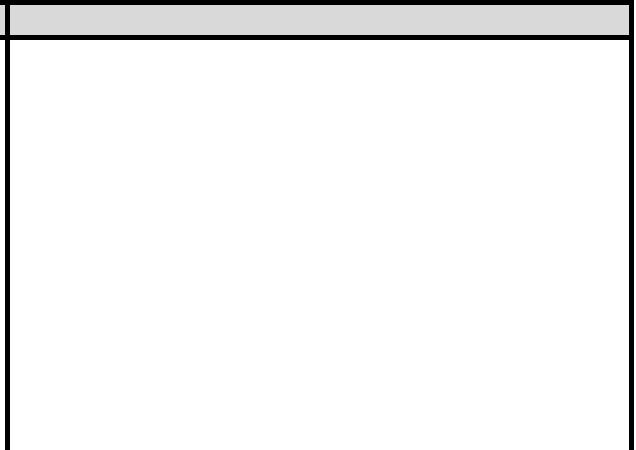
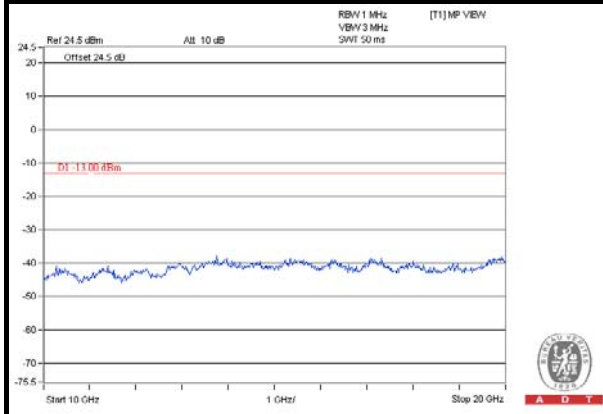



A D T

EDGE

CHANNEL 810

FREQUENCY RANGE : 9kHz~3GHz

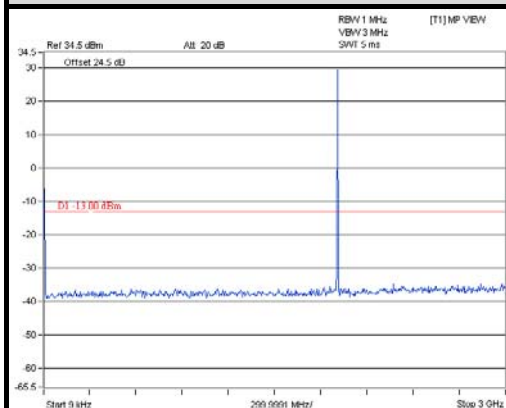

FREQUENCY RANGE : 3GHz~10GHz

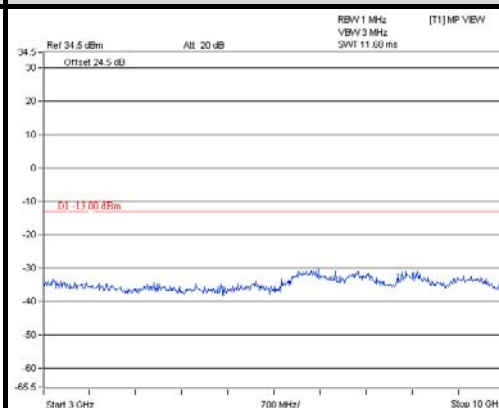

FREQUENCY RANGE : 10GHz~20GHz

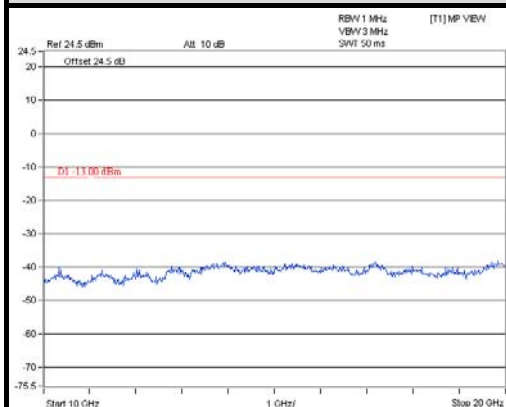



A D T

WCDMA

CHANNEL 9262

FREQUENCY RANGE : 9kHz~3GHz

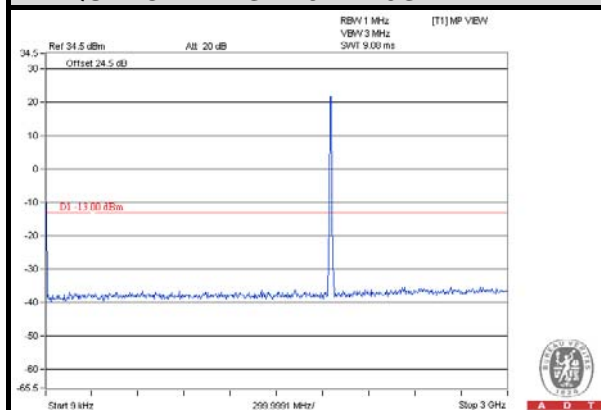

FREQUENCY RANGE : 3GHz~10GHz

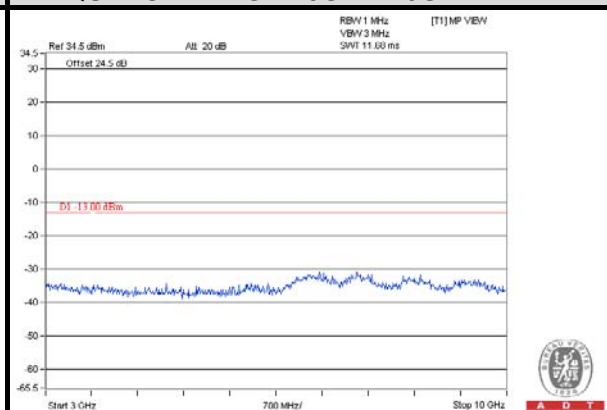

FREQUENCY RANGE : 10GHz~20GHz

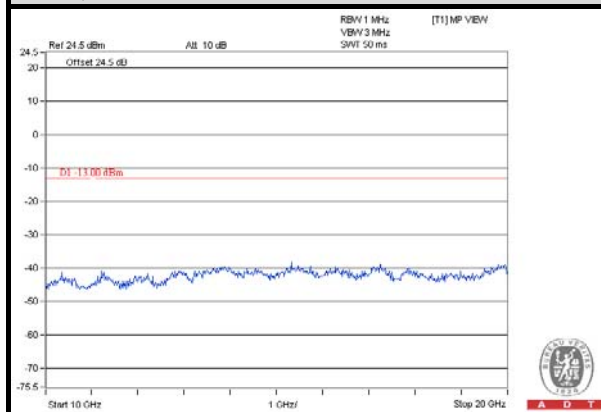



A D T

WCDMA

CHANNEL 9400

FREQUENCY RANGE : 9kHz~3GHz

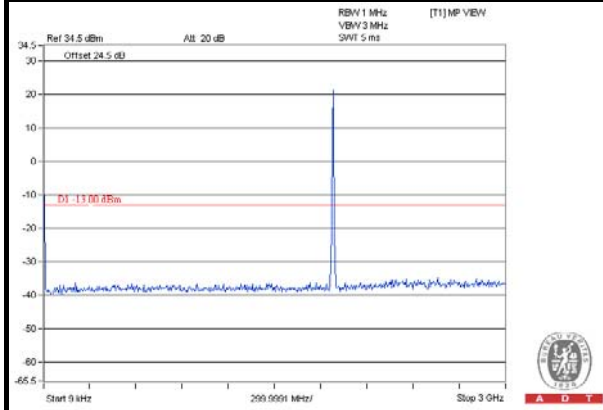

FREQUENCY RANGE : 3GHz~10GHz

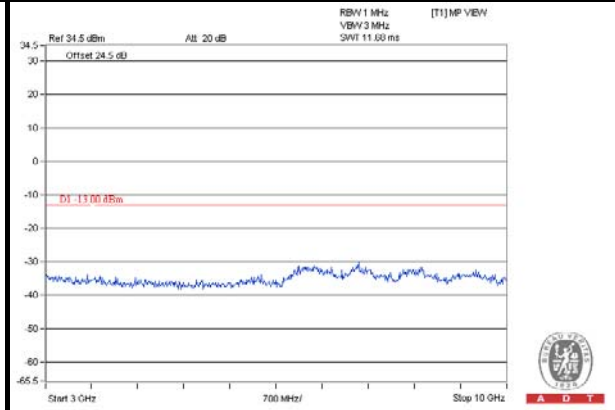

FREQUENCY RANGE : 10GHz~20GHz

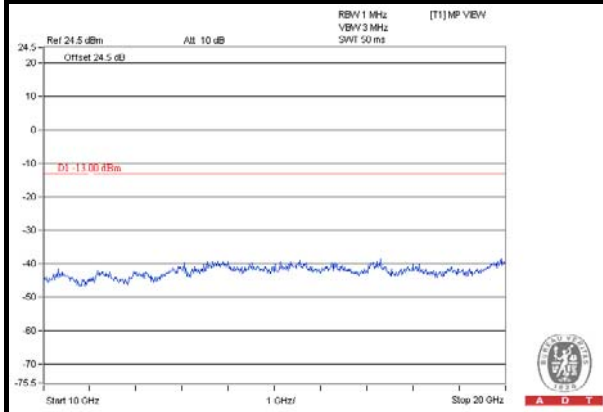



A D T

WCDMA

CHANNEL 9538

FREQUENCY RANGE : 9kHz~3GHz

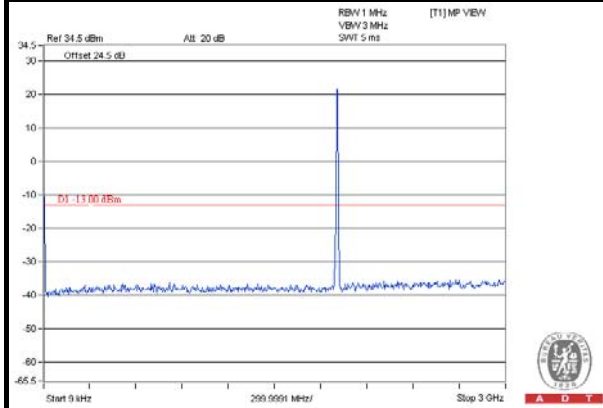

FREQUENCY RANGE : 3GHz~10GHz

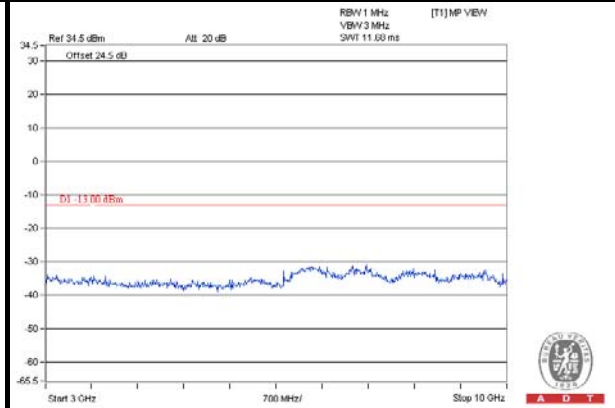

FREQUENCY RANGE : 10GHz~20GHz

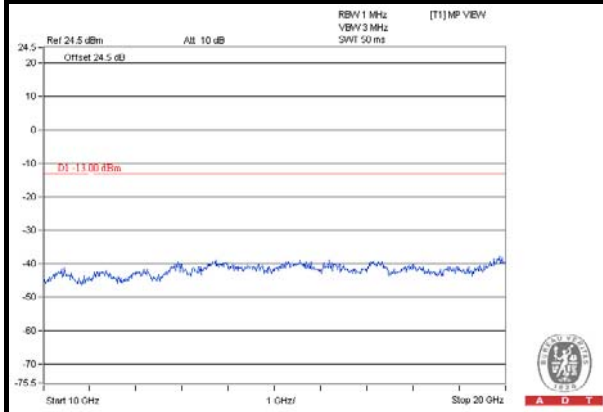



A D T

HSDPA

CHANNEL 9262

FREQUENCY RANGE : 9kHz~3GHz

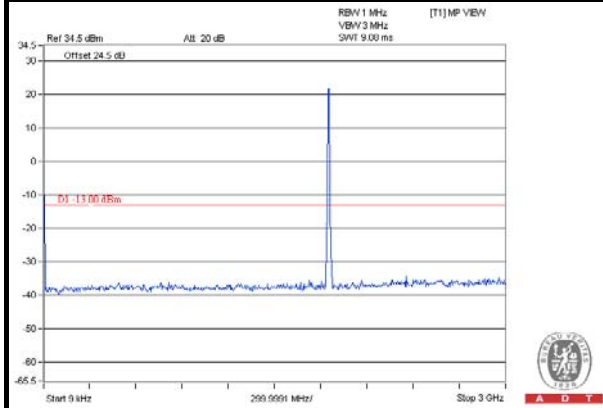

FREQUENCY RANGE : 3GHz~10GHz

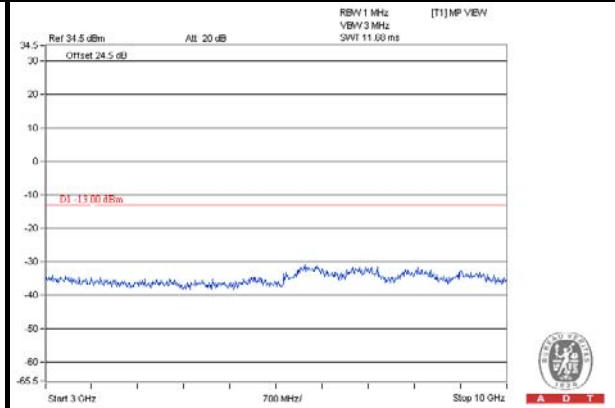

FREQUENCY RANGE : 10GHz~20GHz

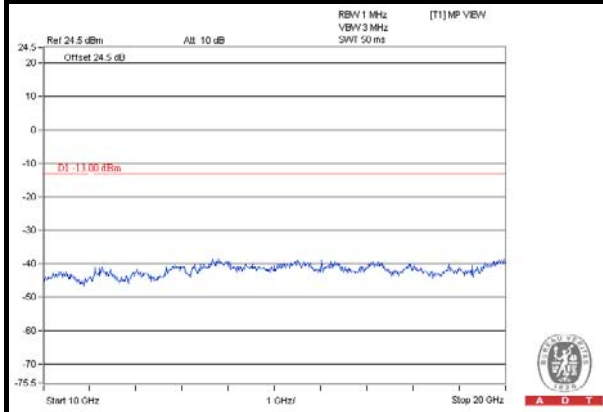



A D T

HSDPA

CHANNEL 9400

FREQUENCY RANGE : 9kHz~3GHz

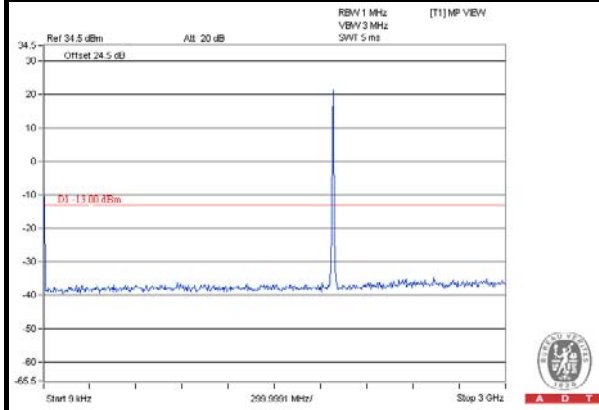

FREQUENCY RANGE : 3GHz~10GHz

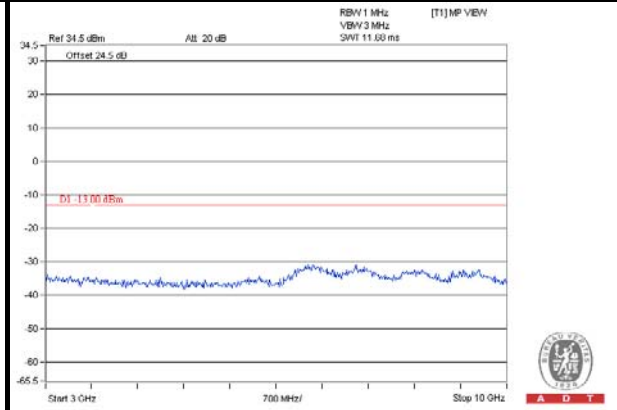

FREQUENCY RANGE : 10GHz~20GHz

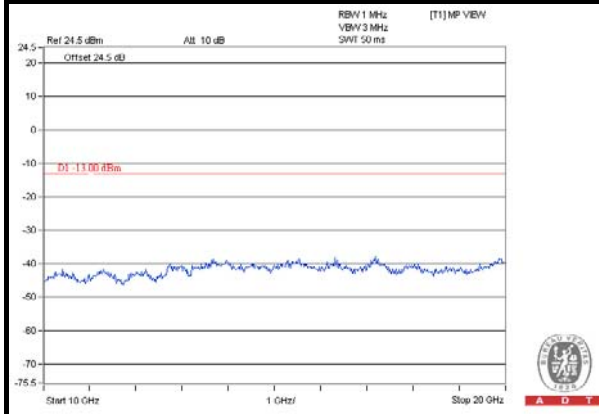



A D T

HSDPA

CHANNEL 9538

FREQUENCY RANGE : 9kHz~3GHz

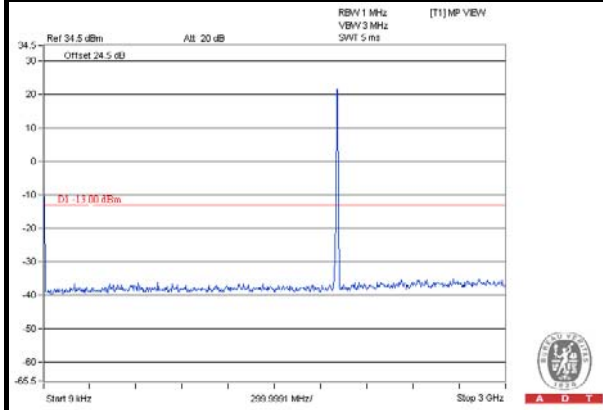

FREQUENCY RANGE : 3GHz~10GHz

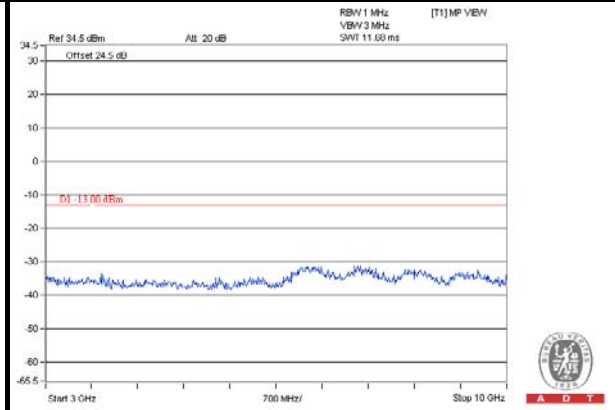

FREQUENCY RANGE : 10GHz~20GHz

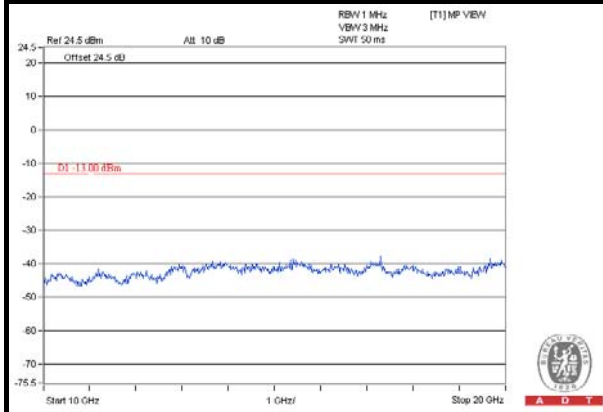



A D T

HSUPA

CHANNEL 9262

FREQUENCY RANGE : 9kHz~3GHz

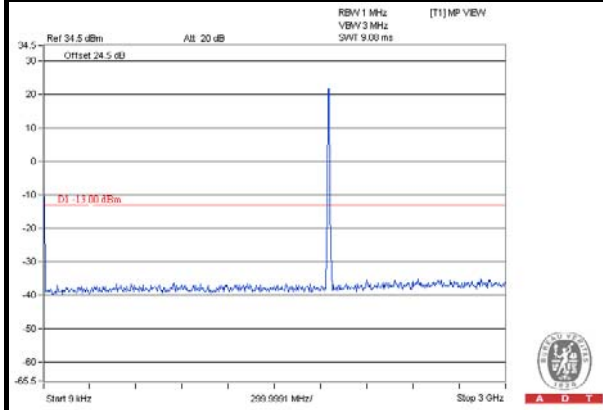

FREQUENCY RANGE : 3GHz~10GHz

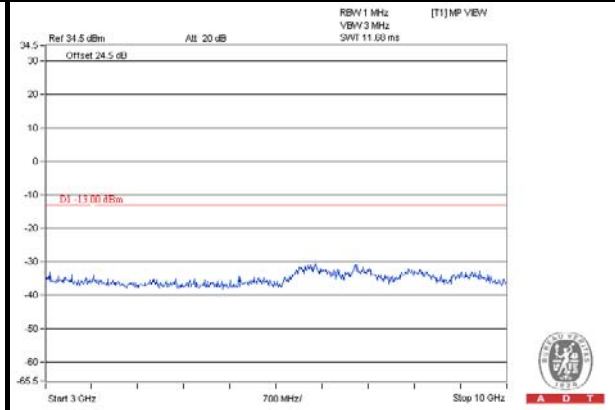

FREQUENCY RANGE : 10GHz~20GHz

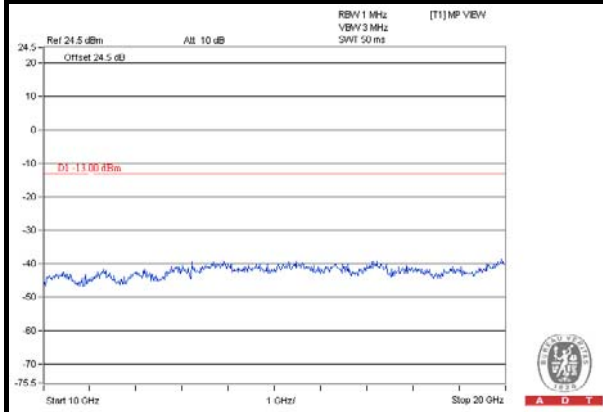



A D T

HSUPA

CHANNEL 9400

FREQUENCY RANGE : 9kHz~3GHz

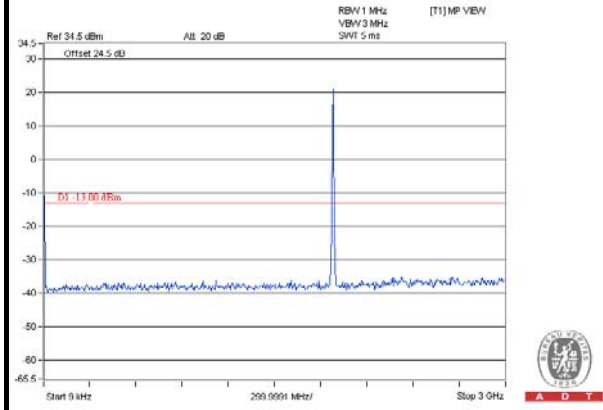

FREQUENCY RANGE : 3GHz~10GHz

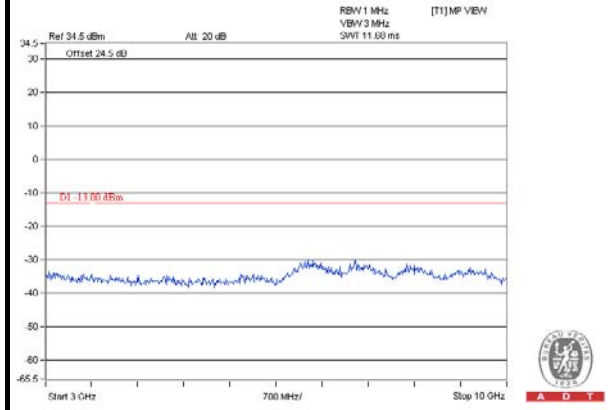

FREQUENCY RANGE : 10GHz~20GHz

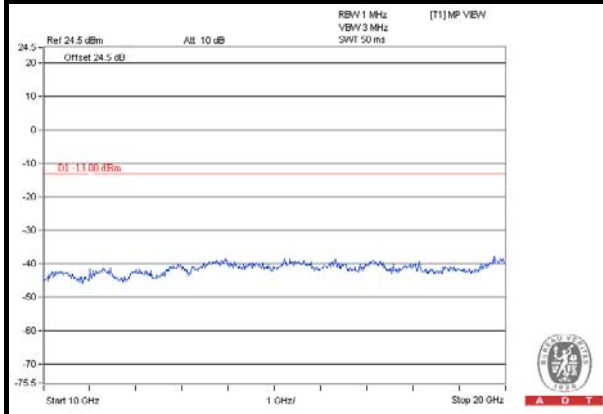



A D T

HSUPA

CHANNEL 9538

FREQUENCY RANGE : 9kHz~3GHz

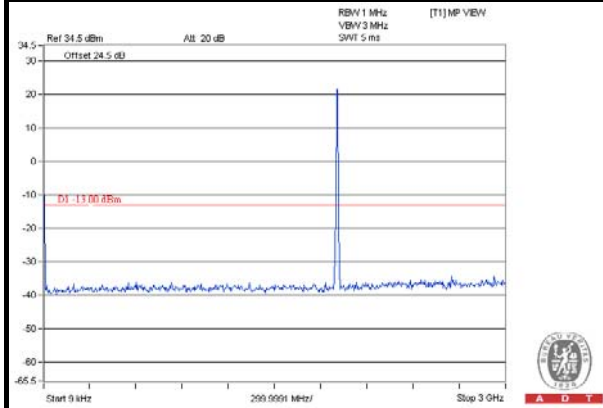

FREQUENCY RANGE : 3GHz~10GHz

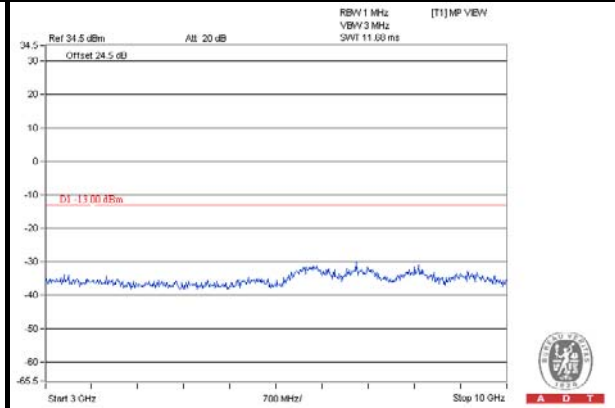

FREQUENCY RANGE : 10GHz~20GHz

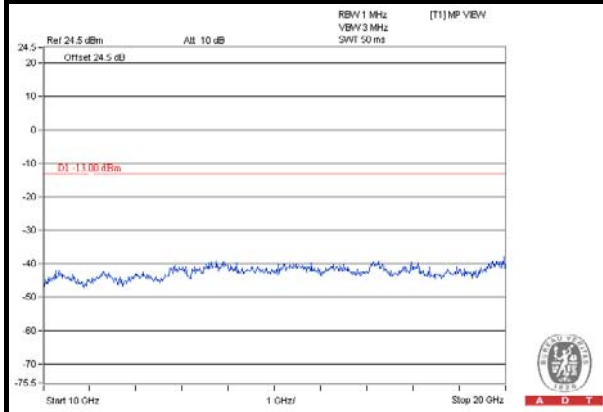

4.6 RADIATED EMISSION MEASUREMENT

4.6.1 LIMITS OF RADIATED EMISSION MEASUREMENT

The power of any emission outside of the authorized operating frequency ranges must be attenuated below the transmitting power (P) by a factor of at least $43 + 10 \log(P)$ dB. The emission limit equal to -13dBm .

4.6.2 TEST PROCEDURES

- a. Substitution method is used for E.I.R.P measurement. In the semi-anechoic chamber, EUT placed on the 0.8m height of Turn Table, rotated the table around 360 degrees to search the maximum radiation power and receiver antenna shall be rotated vertical and horizontal polarization and moved height from 1m to 4m to find the maximum polar radiated power. The “Read Value” is the spectrum reading the maximum power value.
- b. The substitution horn antenna is substituted for EUT at the same position and signals generator export the CW signal to the substitution antenna via a TX cable. Rotated the Turn Table and moved receiving antenna to find the maximum radiation power. Adjust output power level of S.G to get a Value of spectrum reading equal to “Read Value” of step a. Record the power level of S.G
- c. $\text{EIRP} = \text{Output power level of S.G} - \text{TX cable loss} + \text{Antenna gain of substitution horn}$.
- d. E.R.P power can be calculated form E.I.R.P power by subtracting the gain of dipole,
 $\text{E.R.P power} = \text{E.I.R.P power} - 2.15\text{dBi}$.

NOTE: The resolution bandwidth and video bandwidth of test receiver/spectrum analyzer is 1MHz/3MHz.

4.6.3 DEVIATION FROM TEST STANDARD

No deviation

4.6.4 TEST SETUP

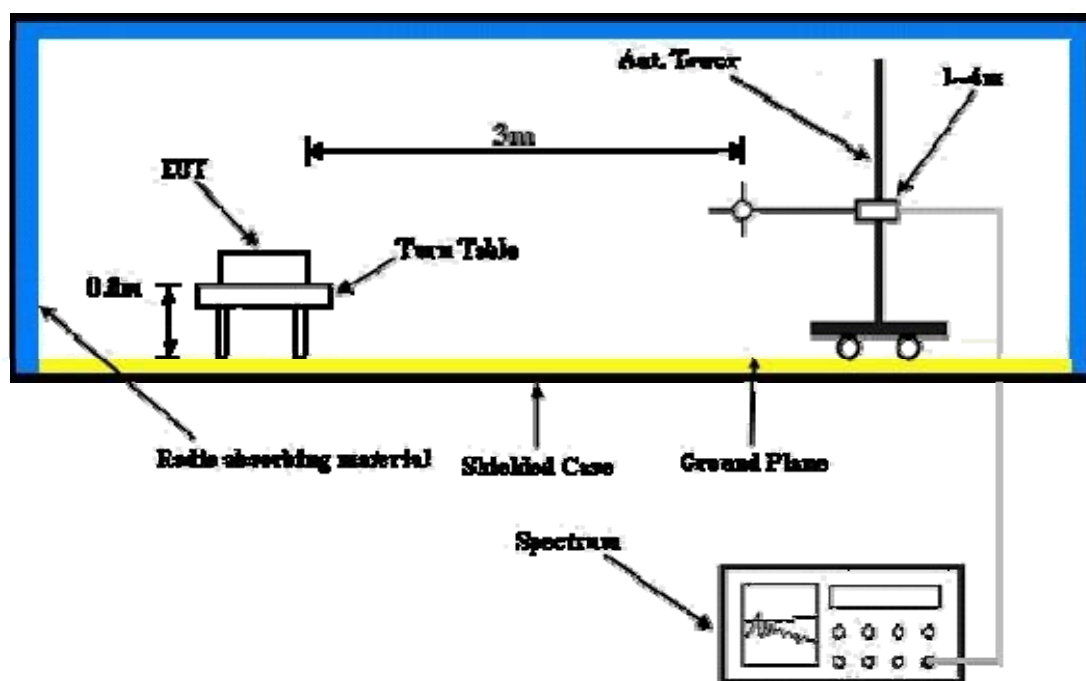

For the actual test configuration, please refer to the attached file (Test Setup Photo).

4.6.5 TEST RESULTS

BELOW 1GHz WORST-CASE DATA:

FOR GPRS MODE

MODE	TX channel 512	FREQUENCY RANGE	Below 1000 MHz
ENVIRONMENTAL CONDITIONS	24deg. C, 68%RH	INPUT POWER	120Vac, 60 Hz
TESTED BY	Jones Chang		

ANTENNA POLARITY & TEST DISTANCE: HORIZONTAL AT 3 M							
No.	Freq. (MHz)	Reading (dBm)	S.G Power Value (dBm)	Correction Factor (dB)	EIRP (dBm)	Limit (dBm)	Margin (dB)
1	418.78	-58.71	-63.31	5.21	-58.10	-13.00	-45.10
2	638.44	-66.68	-69.28	4.75	-64.53	-13.00	-51.53
3	762.85	-68.72	-67.74	4.48	-63.26	-13.00	-50.26
4	838.66	-57.77	-56.38	3.97	-52.41	-13.00	-39.41
5	908.64	-66.86	-64.61	3.91	-60.70	-13.00	-47.70
6	945.57	-67.53	-64.53	3.91	-60.62	-13.00	-47.62
ANTENNA POLARITY & TEST DISTANCE: VERTICAL AT 3 M							
No.	Freq. (MHz)	Reading (dBm)	S.G Power Value (dBm)	Correction Factor (dB)	EIRP (dBm)	Limit (dBm)	Margin (dB)
1	418.78	-59.62	-63.18	5.21	-57.97	-13.00	-44.97
2	630.66	-65.41	-65.33	4.67	-60.66	-13.00	-47.66
3	700.64	-64.64	-63.44	5.24	-58.20	-13.00	-45.20
4	838.66	-58.88	-55.02	3.97	-51.05	-13.00	-38.05
5	906.69	-67.72	-62.43	3.91	-58.52	-13.00	-45.52
6	945.57	-67.64	-61.39	3.91	-57.48	-13.00	-44.48

REMARKS:

1. Power Value (dBm) = S.G Power Value (dBm) + Correction Factor (dB).
2. Correction Factor (dB) = Substitution Antenna Gain (dB) + Cable Loss (dB).



A D T

FOR EDGE MODE

MODE	TX channel 512	FREQUENCY RANGE	Below 1000 MHz
ENVIRONMENTAL CONDITIONS	24deg. C, 68%RH	INPUT POWER	120Vac, 60 Hz
TESTED BY	Jones Chang		

ANTENNA POLARITY & TEST DISTANCE: HORIZONTAL AT 3 M

No.	Freq. (MHz)	Reading (dBm)	S.G Power Value (dBm)	Correction Factor (dB)	EIRP (dBm)	Limit (dBm)	Margin (dB)
1	412.95	-63.18	-68.06	5.23	-62.83	-13.00	-49.83
2	624.83	-66.94	-69.72	4.64	-65.08	-13.00	-52.08
3	733.69	-68.23	-68.20	4.83	-63.37	-13.00	-50.37
4	807.56	-67.73	-66.44	4.02	-62.42	-13.00	-49.42
5	883.37	-69.38	-67.52	3.93	-63.59	-13.00	-50.59
6	931.96	-69.38	-66.65	3.91	-62.74	-13.00	-49.74

ANTENNA POLARITY & TEST DISTANCE: VERTICAL AT 3 M

No.	Freq. (MHz)	Reading (dBm)	S.G Power Value (dBm)	Correction Factor (dB)	EIRP (dBm)	Limit (dBm)	Margin (dB)
1	255.49	-55.01	-63.09	5.37	-57.72	-13.00	-44.72
2	488.76	-66.75	-70.07	4.92	-65.15	-13.00	-52.15
3	519.86	-67.03	-69.83	4.80	-65.03	-13.00	-52.03
4	757.01	-69.45	-66.53	4.55	-61.98	-13.00	-48.98
5	807.56	-67.43	-64.13	4.02	-60.11	-13.00	-47.11
6	990.28	-69.81	-63.05	3.90	-59.15	-13.00	-46.15

REMARKS:

1. Power Value (dBm) = S.G Power Value (dBm) + Correction Factor (dB).
2. Correction Factor (dB) = Substitution Antenna Gain (dB) + Cable Loss (dB).



A D T

FOR WCDMA MODE

MODE	TX channel 9262	FREQUENCY RANGE	Below 1000 MHz
ENVIRONMENTAL CONDITIONS	24deg. C, 68%RH	INPUT POWER	120Vac, 60 Hz
TESTED BY	Jones Chang		

ANTENNA POLARITY & TEST DISTANCE: HORIZONTAL AT 3 M

No.	Freq. (MHz)	Reading (dBm)	S.G Power Value (dBm)	Correction Factor (dB)	EIRP (dBm)	Limit (dBm)	Margin (dB)
1	418.78	-63.98	-68.58	5.21	-63.37	-13.00	-50.37
2	634.55	-66.28	-68.92	4.71	-64.21	-13.00	-51.21
3	702.59	-66.87	-68.47	5.21	-63.26	-13.00	-50.26
4	836.71	-54.81	-53.43	3.98	-49.45	-13.00	-36.45
5	906.69	-68.66	-66.44	3.91	-62.53	-13.00	-49.53
6	953.35	-68.68	-65.54	3.90	-61.64	-13.00	-48.64

ANTENNA POLARITY & TEST DISTANCE: VERTICAL AT 3 M

No.	Freq. (MHz)	Reading (dBm)	S.G Power Value (dBm)	Correction Factor (dB)	EIRP (dBm)	Limit (dBm)	Margin (dB)
1	377.96	-64.82	-69.82	5.24	-64.58	-13.00	-51.58
2	414.89	-64.48	-68.30	5.23	-63.07	-13.00	-50.07
3	630.66	-67.34	-67.26	4.67	-62.59	-13.00	-49.59
4	681.20	-66.55	-65.68	5.09	-60.59	-13.00	-47.59
5	702.59	-65.35	-64.07	5.21	-58.86	-13.00	-45.86
6	945.57	-69.12	-62.87	3.91	-58.96	-13.00	-45.96

REMARKS:

1. Power Value (dBm) = S.G Power Value (dBm) + Correction Factor (dB).
2. Correction Factor (dB) = Substitution Antenna Gain (dB) + Cable Loss (dB).



A D T

ABOVE 1GHz

FOR GPRS MODE

MODE	TX channel 512	FREQUENCY RANGE	Above 1000 MHz
ENVIRONMENTAL CONDITIONS	24deg. C, 68%RH	INPUT POWER	120Vac, 60 Hz
TESTED BY	Jones Chang		

ANTENNA POLARITY & TEST DISTANCE: HORIZONTAL AT 3 M							
No.	Freq. (MHz)	Reading (dBm)	S.G Power Value (dBm)	Correction Factor (dB)	EIRP (dBm)	Limit (dBm)	Margin (dB)
1	3700.20	-62.21	-58.12	7.16	-50.96	-13.00	-37.96
2	5550.60	-64.32	-53.37	6.78	-46.59	-13.00	-33.59
ANTENNA POLARITY & TEST DISTANCE: VERTICAL AT 3 M							
No.	Freq. (MHz)	Reading (dBm)	S.G Power Value (dBm)	Correction Factor (dB)	EIRP (dBm)	Limit (dBm)	Margin (dB)
1	3700.20	-62.75	-58.88	7.16	-51.72	-13.00	-38.72
2	5550.60	-64.96	-55.51	6.78	-48.73	-13.00	-35.73

REMARKS:

1. Power Value (dBm) = S.G Power Value (dBm) + Correction Factor (dB).
2. Correction Factor (dB) = Substitution Antenna Gain (dB) + Cable Loss (dB).



A D T

MODE	TX channel 661	FREQUENCY RANGE	Above 1000 MHz
ENVIRONMENTAL CONDITIONS	24deg. C, 68%RH	INPUT POWER	120Vac, 60 Hz
TESTED BY	Jones Chang		

ANTENNA POLARITY & TEST DISTANCE: HORIZONTAL AT 3 M							
No.	Freq. (MHz)	Reading (dBm)	S.G Power Value (dBm)	Correction Factor (dB)	EIRP (dBm)	Limit (dBm)	Margin (dB)
1	3760.00	-62.69	-58.34	7.10	-51.24	-13.00	-38.24
2	5640.00	-63.44	-52.44	6.77	-45.67	-13.00	-32.67

ANTENNA POLARITY & TEST DISTANCE: VERTICAL AT 3 M							
No.	Freq. (MHz)	Reading (dBm)	S.G Power Value (dBm)	Correction Factor (dB)	EIRP (dBm)	Limit (dBm)	Margin (dB)
1	3760.00	-59.54	-55.53	7.10	-48.43	-13.00	-35.43
2	5640.00	-61.13	-51.36	6.77	-44.59	-13.00	-31.59

REMARKS:

1. Power Value (dBm) = S.G Power Value (dBm) + Correction Factor (dB).
2. Correction Factor (dB) = Substitution Antenna Gain (dB) + Cable Loss (dB).



A D T

MODE	TX channel 810	FREQUENCY RANGE	Above 1000 MHz
ENVIRONMENTAL CONDITIONS	24deg. C, 68%RH	INPUT POWER	120Vac, 60 Hz
TESTED BY	Jones Chang		

ANTENNA POLARITY & TEST DISTANCE: HORIZONTAL AT 3 M							
No.	Freq. (MHz)	Reading (dBm)	S.G Power Value (dBm)	Correction Factor (dB)	EIRP (dBm)	Limit (dBm)	Margin (dB)
1	3819.60	-61.50	-56.89	7.05	-49.84	-13.00	-36.84
2	5729.40	-63.22	-52.14	6.74	-45.40	-13.00	-32.40

ANTENNA POLARITY & TEST DISTANCE: VERTICAL AT 3 M							
No.	Freq. (MHz)	Reading (dBm)	S.G Power Value (dBm)	Correction Factor (dB)	EIRP (dBm)	Limit (dBm)	Margin (dB)
1	3819.60	-60.46	-56.32	7.05	-49.27	-13.00	-36.27
2	5729.40	-62.43	-52.31	6.74	-45.57	-13.00	-32.57

REMARKS:

1. Power Value (dBm) = S.G Power Value (dBm) + Correction Factor (dB).
2. Correction Factor (dB) = Substitution Antenna Gain (dB) + Cable Loss (dB).



A D T

FOR EDGE MODE

MODE	TX channel 512	FREQUENCY RANGE	Above 1000 MHz
ENVIRONMENTAL CONDITIONS	24deg. C, 68%RH	INPUT POWER	120Vac, 60 Hz
TESTED BY	Jones Chang		

ANTENNA POLARITY & TEST DISTANCE: HORIZONTAL AT 3 M							
No.	Freq. (MHz)	Reading (dBm)	S.G Power Value (dBm)	Correction Factor (dB)	EIRP (dBm)	Limit (dBm)	Margin (dB)
1	3700.20	-62.71	-58.62	7.16	-51.46	-13.00	-38.46
2	5550.60	-64.92	-53.97	6.78	-47.19	-13.00	-34.19

ANTENNA POLARITY & TEST DISTANCE: VERTICAL AT 3 M							
No.	Freq. (MHz)	Reading (dBm)	S.G Power Value (dBm)	Correction Factor (dB)	EIRP (dBm)	Limit (dBm)	Margin (dB)
1	3700.20	-63.87	-60.00	7.16	-52.84	-13.00	-39.84
2	5550.60	-66.10	-56.65	6.78	-49.87	-13.00	-36.87

REMARKS:

- 1. Power Value (dBm) = S.G Power Value (dBm) + Correction Factor (dB).
- 2. Correction Factor (dB) = Substitution Antenna Gain (dB) + Cable Loss (dB).



A D T

MODE	TX channel 661	FREQUENCY RANGE	Above 1000 MHz
ENVIRONMENTAL CONDITIONS	24deg. C, 68%RH	INPUT POWER	120Vac, 60 Hz
TESTED BY	Jones Chang		

ANTENNA POLARITY & TEST DISTANCE: HORIZONTAL AT 3 M							
No.	Freq. (MHz)	Reading (dBm)	S.G Power Value (dBm)	Correction Factor (dB)	EIRP (dBm)	Limit (dBm)	Margin (dB)
1	3760.00	-62.77	-58.42	7.10	-51.32	-13.00	-38.32
2	5640.00	-63.93	-52.93	6.77	-46.16	-13.00	-33.16
ANTENNA POLARITY & TEST DISTANCE: VERTICAL AT 3 M							
No.	Freq. (MHz)	Reading (dBm)	S.G Power Value (dBm)	Correction Factor (dB)	EIRP (dBm)	Limit (dBm)	Margin (dB)
1	3760.00	-60.00	-55.99	7.10	-48.89	-13.00	-35.89
2	5640.00	-63.13	-53.36	6.77	-46.59	-13.00	-33.59

REMARKS:

1. Power Value (dBm) = S.G Power Value (dBm) + Correction Factor (dB).
2. Correction Factor (dB) = Substitution Antenna Gain (dB) + Cable Loss (dB).



A D T

MODE	TX channel 810	FREQUENCY RANGE	Above 1000 MHz
ENVIRONMENTAL CONDITIONS	24deg. C, 68%RH	INPUT POWER	120Vac, 60 Hz
TESTED BY	Jones Chang		

ANTENNA POLARITY & TEST DISTANCE: HORIZONTAL AT 3 M							
No.	Freq. (MHz)	Reading (dBm)	S.G Power Value (dBm)	Correction Factor (dB)	EIRP (dBm)	Limit (dBm)	Margin (dB)
1	3819.60	-62.50	-57.89	7.05	-50.84	-13.00	-37.84
2	5729.40	-65.00	-53.92	6.74	-47.18	-13.00	-34.18

ANTENNA POLARITY & TEST DISTANCE: VERTICAL AT 3 M							
No.	Freq. (MHz)	Reading (dBm)	S.G Power Value (dBm)	Correction Factor (dB)	EIRP (dBm)	Limit (dBm)	Margin (dB)
1	3819.60	-61.55	-57.41	7.05	-50.36	-13.00	-37.36
2	5729.40	-64.84	-54.72	6.74	-47.98	-13.00	-34.98

REMARKS:

1. Power Value (dBm) = S.G Power Value (dBm) + Correction Factor (dB).
2. Correction Factor (dB) = Substitution Antenna Gain (dB) + Cable Loss (dB).



A D T

FOR WCDMA MODE

MODE	TX channel 9262	FREQUENCY RANGE	Above 1000 MHz
ENVIRONMENTAL CONDITIONS	24deg. C, 68%RH	INPUT POWER	120Vac, 60 Hz
TESTED BY	Jones Chang		

ANTENNA POLARITY & TEST DISTANCE: HORIZONTAL AT 3 M							
No.	Freq. (MHz)	Reading (dBm)	S.G Power Value (dBm)	Correction Factor (dB)	EIRP (dBm)	Limit (dBm)	Margin (dB)
1	3704.80	-59.12	-55.01	7.15	-47.86	-13.00	-34.86
2	5557.20	-62.93	-51.97	6.78	-45.19	-13.00	-32.19

ANTENNA POLARITY & TEST DISTANCE: VERTICAL AT 3 M							
No.	Freq. (MHz)	Reading (dBm)	S.G Power Value (dBm)	Correction Factor (dB)	EIRP (dBm)	Limit (dBm)	Margin (dB)
1	3704.80	-56.01	-52.13	7.15	-44.98	-13.00	-31.98
2	5557.20	-54.79	-45.32	6.78	-38.54	-13.00	-25.54

REMARKS:

1. Power Value (dBm) = S.G Power Value (dBm) + Correction Factor (dB).
2. Correction Factor (dB) = Substitution Antenna Gain (dB) + Cable Loss (dB).



A D T

MODE	TX channel 9400	FREQUENCY RANGE	Above 1000 MHz
ENVIRONMENTAL CONDITIONS	24deg. C, 68%RH	INPUT POWER	120Vac, 60 Hz
TESTED BY	Jones Chang		

ANTENNA POLARITY & TEST DISTANCE: HORIZONTAL AT 3 M							
No.	Freq. (MHz)	Reading (dBm)	S.G Power Value (dBm)	Correction Factor (dB)	EIRP (dBm)	Limit (dBm)	Margin (dB)
1	3704.80	-61.12	-57.01	7.15	-49.86	-13.00	-36.86
2	5557.20	-63.03	-52.07	6.78	-45.29	-13.00	-32.29

ANTENNA POLARITY & TEST DISTANCE: VERTICAL AT 3 M							
No.	Freq. (MHz)	Reading (dBm)	S.G Power Value (dBm)	Correction Factor (dB)	EIRP (dBm)	Limit (dBm)	Margin (dB)
1	3704.80	-58.01	-54.13	7.15	-46.98	-13.00	-33.98
2	5557.20	-56.79	-47.32	6.78	-40.54	-13.00	-27.54

REMARKS:

1. Power Value (dBm) = S.G Power Value (dBm) + Correction Factor (dB).
2. Correction Factor (dB) = Substitution Antenna Gain (dB) + Cable Loss (dB).



A D T

MODE	TX channel 9538	FREQUENCY RANGE	Above 1000 MHz
ENVIRONMENTAL CONDITIONS	24deg. C, 68%RH	INPUT POWER	120Vac, 60 Hz
TESTED BY	Jones Chang		

ANTENNA POLARITY & TEST DISTANCE: HORIZONTAL AT 3 M							
No.	Freq. (MHz)	Reading (dBm)	S.G Power Value (dBm)	Correction Factor (dB)	EIRP (dBm)	Limit (dBm)	Margin (dB)
1	3815.20	-62.32	-57.74	7.06	-50.68	-13.00	-37.68
2	5722.80	-63.56	-52.49	6.74	-45.75	-13.00	-32.75

ANTENNA POLARITY & TEST DISTANCE: VERTICAL AT 3 M							
No.	Freq. (MHz)	Reading (dBm)	S.G Power Value (dBm)	Correction Factor (dB)	EIRP (dBm)	Limit (dBm)	Margin (dB)
1	3815.20	-59.56	-55.44	7.06	-48.38	-13.00	-35.38
2	5722.80	-60.58	-50.49	6.74	-43.75	-13.00	-30.75

REMARKS:

1. Power Value (dBm) = S.G Power Value (dBm) + Correction Factor (dB).
2. Correction Factor (dB) = Substitution Antenna Gain (dB) + Cable Loss (dB).



A D T

5 PHOTOGRAPHS OF THE TEST CONFIGURATION

Please refer to the attached file (Test Setup Photo).



A D T

6 INFORMATION ON THE TESTING LABORATORIES

We, Bureau Veritas Consumer Products Services (H.K.) Ltd., Taoyuan Branch, were founded in 1988 to provide our best service in EMC, Radio, Telecom and Safety consultation. Our laboratories are accredited and approved according to ISO/IEC 17025.

If you have any comments, please feel free to contact us at the following:

Linko EMC/RF Lab:

Tel: 886-2-26052180

Fax: 886-2-26051924

Hsin Chu EMC/RF Lab:

Tel: 886-3-5935343

Fax: 886-3-5935342

Hwa Ya EMC/RF/Safety/Telecom Lab:

Tel: 886-3-3183232

Fax: 886-3-3270892

Email: service.adt@tw.bureauveritas.com

Web Site: www.bureauveritas-adt.com

The address and road map of all our labs can be found in our web site also.



A D T

7 APPENDIX A – MODIFICATIONS RECORDERS FOR ENGINEERING CHANGES TO THE EUT BY THE LAB

No any modifications are made to the EUT by the lab during the test.

---END---