

FCC Test Report (Part 27)

Report No.: RF151229C25-8

FCC ID: M82-TREK733L

Test Model: TREK-733L

Received Date: Apr. 14, 2016

Test Date: Jun. 13 ~ Aug. 05, 2016

Issued Date: Aug. 10, 2016

Applicant: ADVANTECH CO., LTD

Address: No.1, Alley 20, Lane 26, Rueiguang Rd, Neihu District, Taipei, Taiwan 114

Issued By: Bureau Veritas Consumer Products Services (H.K.) Ltd., Taoyuan Branch

Lab Address: No. 47-2, 14th Ling, Chia Pau Vil., Lin Kou Dist., New Taipei City, Taiwan (R.O.C.)

Test Location: No. 19, Hwa Ya 2nd Rd., Wen Hwa Vil., Kwei Shan Dist., Taoyuan City 33383, TAIWAN (R.O.C.)



This report is for your exclusive use. Any copying or replication of this report to or for any other person or entity, or use of our name or trademark, is permitted only with our prior written permission. This report sets forth our findings solely with respect to the test samples identified herein. The results set forth in this report are not indicative or representative of the quality or characteristics of the lot from which a test sample was taken or any similar or identical product unless specifically and expressly noted. Our report includes all of the tests requested by you and the results thereof based upon the information that you provided to us. You have 60 days from date of issuance of this report to notify us of any material error or omission caused by our negligence, provided, however, that such notice shall be in writing and shall specifically address the issue you wish to raise. A failure to raise such issue within the prescribed time shall constitute your unqualified acceptance of the completeness of this report, the tests conducted and the correctness of the report contents. Unless specific mention, the uncertainty of measurement has been explicitly taken into account to declare the compliance or non-compliance to the specification. The report must not be used by the client to claim product certification, approval, or endorsement by TAF or any government agencies

Table of Contents

Release Control Record	3
1 Certificate of Conformity	4
2 Summary of Test Results	5
2.1 Measurement Uncertainty.....	5
2.2 Test Site and Instruments.....	6
3 General Information	7
3.1 General Description of EUT.....	7
3.2 Configuration of System Under Test.....	8
3.2.1 Description of Support Units.....	8
3.3 Test Mode Applicability and Tested Channel Detail.....	9
3.4 EUT Operating Conditions.....	10
3.5 General Description of Applied Standards.....	10
4 Test Types and Results	11
4.1 Output Power Measurement.....	11
4.1.1 Limits of Output Power Measurement.....	11
4.1.2 Test Procedures.....	11
4.1.3 Test Setup.....	12
4.1.4 Test Results.....	13
4.2 Frequency Stability Measurement.....	15
4.2.1 Limits of Frequency Stability Measurement.....	15
4.2.2 Test Procedure.....	15
4.2.3 Test Setup.....	15
4.2.4 Test Results.....	16
4.3 Emission Bandwidth Measurement.....	17
4.3.1 Limits of Emission Bandwidth Measurement.....	17
4.3.2 Test Procedure.....	17
4.3.3 Test Setup.....	17
4.3.4 Test Result.....	18
4.4 Channel Edge Measurement.....	20
4.4.1 Limits of Band Edge Measurement.....	20
4.4.2 Test Setup.....	20
4.4.3 Test Procedures.....	20
4.4.4 Test Results.....	21
4.5 Peak To Average Ratio.....	22
4.5.1 Limits of Peak To Average Ratio Measurement.....	22
4.5.2 Test Setup.....	22
4.5.3 Test Procedures.....	22
4.5.4 Test Results.....	23
4.6 Conducted Spurious Emissions.....	24
4.6.1 Limits of Conducted Spurious Emissions Measurement.....	24
4.6.2 Test Setup.....	24
4.6.3 Test Procedure.....	24
4.6.4 Test Results.....	25
4.7 Radiated Emission Measurement.....	34
4.7.1 Limits of Radiated Emission Measurement.....	34
4.7.2 Test Procedure.....	34
4.7.3 Deviation from Test Standard.....	34
4.7.4 Test Setup.....	35
4.7.5 Test Results.....	36
5 Pictures of Test Arrangements	39
Appendix – Information on the Testing Laboratories	40

Release Control Record

Issue No.	Description	Date Issued
RF151229C25-8	Original release.	Aug. 10, 2016

1 Certificate of Conformity

Product: Computer

Brand: Advantech

Test Model: TREK-733L

Sample Status: Engineering sample

Applicant: ADVANTECH CO., LTD

Test Date: Jun. 13 ~ Aug. 05, 2016

Standards: FCC Part 27, Subpart L

The above equipment has been tested by **Bureau Veritas Consumer Products Services (H.K.) Ltd., Taoyuan Branch**, and found compliance with the requirement of the above standards. The test record, data evaluation & Equipment Under Test (EUT) configurations represented herein are true and accurate accounts of the measurements of the sample's EMC characteristics under the conditions specified in this report.

Prepared by : Celine Chou , **Date:** Aug. 10, 2016
Celine Chou / Specialist

Approved by : Bruce Chen , **Date:** Aug. 10, 2016
Bruce Chen / Project Engineer

2 Summary of Test Results

Applied Standard: FCC Part 27 & Part 2			
FCC Clause	Test Item	Result	Remarks
2.1046 27.50(d)(4)	Equivalent Isotropically Radiated Power	Pass	Meet the requirement of limit.
---	Peak To Average Ratio	Pass	Meet the requirement of limit.
2.1055 27.54	Frequency Stability Stay with the authorized bands of operation	Pass	Meet the requirement of limit.
2.1049 27.53(m)(6)	Emission Bandwidth	Pass	Meet the requirement of limit.
2.1051 27.53(h)	Band Edge Measurements	Pass	Meet the requirement of limit.
2.1051 27.53(h)	Conducted Spurious Emissions	Pass	Meet the requirement of limit.
2.1051 27.53(h)	Radiated Spurious Emissions	Pass	Meet the requirement of limit. Minimum passing margin is -29.5dB at 3505.20MHz.

2.1 Measurement Uncertainty

Where relevant, the following measurement uncertainty levels have been estimated for tests performed on the EUT as specified in CISPR 16-4-2:

Measurement	Frequency	Expanded Uncertainty (k=2) (\pm)
Radiated Emissions up to 1 GHz	30MHz ~ 200MHz	3.86 dB
	200MHz ~1000MHz	3.87 dB
Radiated Emissions above 1 GHz	1GHz ~ 18GHz	2.29 dB
	18GHz ~ 40GHz	2.29 dB

2.2 Test Site and Instruments

Description & Manufacturer	Model No.	Serial No.	Cal. Date	Cal. Due
Test Receiver ROHDE & SCHWARZ	ESIB7	100187	Apr. 18, 2016	Apr. 17, 2017
Spectrum Analyzer ROHDE & SCHWARZ	FSP40	100041	Sep. 02, 2015	Sep. 01, 2016
BILOG Antenna SCHWARZBECK	VULB9168	9168-171	Jan. 07, 2016	Jan. 06, 2017
HORN Antenna SCHWARZBECK	9120D	209	Jan. 20, 2016	Jan. 19, 2017
HORN Antenna SCHWARZBECK	BBHA 9170	BBHA9170241	Jan. 18, 2016	Jan. 17, 2017
Preamplifier Agilent	8447D	2944A10738	Oct. 18, 2015	Oct. 17, 2016
Preamplifier Agilent	8449B	3008A01964	Aug. 22, 2015	Aug. 21, 2016
RF signal cable HUBER+SUHNER	SUCOFLEX 104	Cable-CH3-03 (214378)	Aug. 22, 2015	Aug. 21, 2016
RF signal cable HUBER+SUHNER	SUCOFLEX 106	Cable-CH3-03 (309224+12738)	Aug. 22, 2015	Aug. 21, 2016
Software BV ADT	ADT_Radiated_ V7.6.15.9.4	NA	NA	NA
Antenna Tower inn-co GmbH	MA 4000	013303	NA	NA
Antenna Tower Controller BV ADT	AT100	AT93021702	NA	NA
Turn Table BV ADT	TT100	TT93021702	NA	NA
Turn Table Controller BV ADT	SC100	SC93021702	NA	NA
WIT Standard Temperature And Humidity Chamber	TH-4S-C	W981030	Jun. 08, 2016	Jun. 07, 2017
Mini-Circuits Power Splitter	ZN2PD-9G	NA	Jun. 09, 2016	Jun. 08, 2017
JFW 20dB attenuation	50HF-020-SMA	NA	NA	NA

- Note:
1. The calibration interval of the above test instruments is 12 months and the calibrations are traceable to NML/ROC and NIST/USA.
 2. The test was performed in HwaYa Chamber 3.
 3. The horn antenna and preamplifier (model: 8449B) are used only for the measurement of emission frequency above 1GHz if tested.
 4. The FCC Site Registration No. is 988962.
 5. The IC Site Registration No. is IC 7450F-3.

3 General Information

3.1 General Description of EUT

Product	Computer
Brand	Advantech
Test Model	TREK-733L
Sample Status	Engineering sample
Nominal Voltage	12 or 24Vdc (Car power system) 3.6Vdc (Battery)
Modulation Type	WCDMA: BPSK, QPSK HSDPA: BPSK HSUPA: QPSK
Operating Frequency	1712.4MHz ~ 1752.6MHz
Max. EIRP Power	128.825mW (21.1dBm)
Antenna Type	Refer to Note
Antenna Connector	Refer to Note
Accessory Device	Stand, GPS + LTE antenna, LTE antenna, Core (For power cable), Battery
Data Cable Supplied	2.1m Display cable with 1 core 5m Coaxial cable without core (For GPS + LTE antenna) 5.1m Coaxial cable without core (For LTE antenna) 0.27m power cable with one external ferrite core

Note:

1. The EUT provides 1 completed transmitter (Fixed on chain 0) and 2 receivers.
2. The EUT uses following antennas.

Antenna	Brand	Frequency Range (MHz)	Antenna Gain (dBi)	Antenna Type	Antenna Connector
WWAN (Main) – Chain 0	JEM	1850-1910	0.9	Dipole	SMA
		1710-1755	-0.5		
		824-849	0.5		
		777-787	0.2		
		704-716	0.2		
		1920-1980	-0.4		
WWAN (Aux) – Chain 1	JEM	1850-1910	1.2	Dipole	SMA
		1710-1755	1.8		
		824-849	-0.1		
		777-787	1		
		704-716	1		
		1920-1980	0.7		
WiFi & BT	JEM	2400-2483.5	2.87	PCB	i-pex(MHF)

3. The EUT was operated with following battery:

Battery	
Brand:	Formosan
Model:	GP01NCR18650PF
Rating:	3.6Vdc, 2270mA

4. WLAN 2.4GHz, WWAN 2/3G and LTE 4G technologies can transmit at same time.

5. Spurious emission of the simultaneous operation (WLAN 2.4GHz, WWAN 2/3G and LTE 4G) has been evaluated and no non-compliance was found.

3.2 Configuration of System Under Test

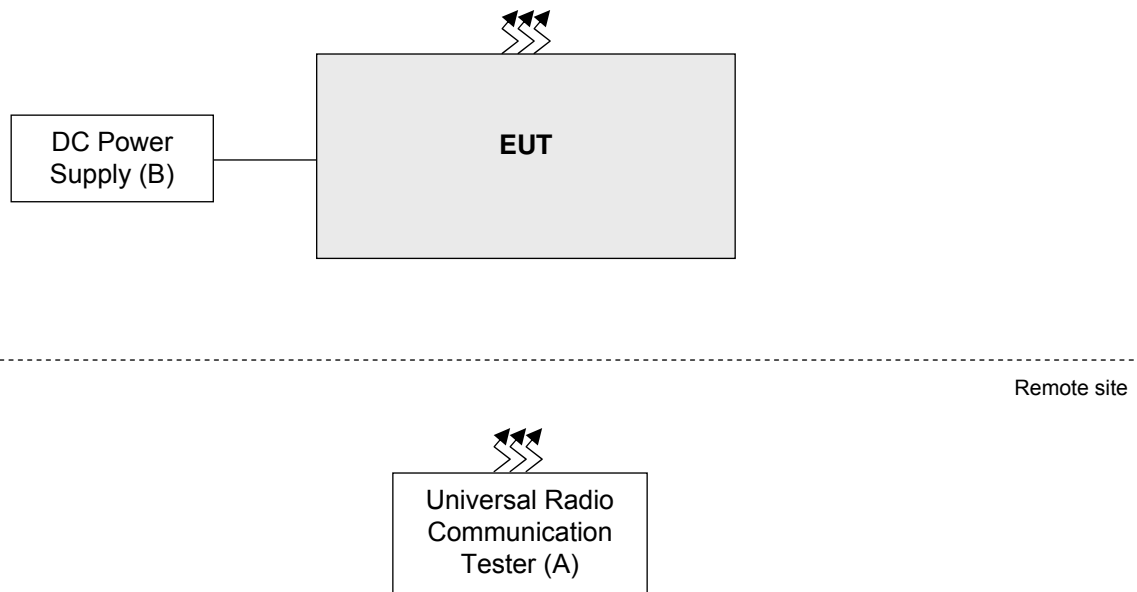

3.2.1 Description of Support Units

The EUT has been tested as an independent unit together with other necessary accessories or support units. The following support units or accessories were used to form a representative test configuration during the tests.

ID	Product	Brand	Model No.	Serial No.	FCC ID	Remarks
A.	Universal Radio Communication Tester	R&S	CMU200	123112	NA	-
B.	DC Power Supply	Topward	6603D	700637	NA	-

Note:

1. All power cords of the above support units are non-shielded (1.8m).
2. Item A acted as a communication partner to transfer data.

3.3 Test Mode Applicability and Tested Channel Detail

Pre-Scan has been conducted to determine the worst-case mode from all possible combinations between available modulations, data rates, XYZ axis and antenna ports. The worst case was found when positioned on Z-plane. Following channel(s) was (were) selected for the final test as listed below:

WCDMA Band 4 Mode

EUT Configure Mode	Test Item	Available Channel	Tested Channel	Mode
-	EIRP	1312 to 1513	1312, 1413, 1513	WCDMA
-	Frequency Stability	1312 to 1513	1413	WCDMA
-	Occupied Bandwidth	1312 to 1513	1312, 1413, 1513	WCDMA, HSDPA, HSUPA
-	Band Edge	1312 to 1513	1312, 1513	WCDMA, HSDPA, HSUPA
-	Peak To Average Ratio	1312 to 1513	1312, 1413, 1513	WCDMA, HSDPA, HSUPA
-	Conducted Emission	1312 to 1513	1312, 1413, 1513	WCDMA, HSDPA, HSUPA
-	Radiated Emission Below 1GHz	1312 to 1513	1312	WCDMA
-	Radiated Emission Above 1GHz	1312 to 1513	1312, 1413, 1513	WCDMA

Test Condition:

Test Item	Environmental Conditions	Input Power (System)	Tested By
EIRP	24deg. C, 64%RH	120Vac, 60Hz	Chris Lin
Frequency Stability	24deg. C, 64%RH	120Vac, 60Hz	Match Tsui
Occupied Bandwidth	24deg. C, 64%RH	120Vac, 60Hz	Match Tsui
Band Edge	24deg. C, 64%RH	120Vac, 60Hz	Match Tsui
Peak To Average Ratio	24deg. C, 64%RH	120Vac, 60Hz	Match Tsui
Conducted Emission	24deg. C, 64%RH	120Vac, 60Hz	Match Tsui
Radiated Emission	24deg. C, 68%RH	120Vac, 60Hz	Alan Wu

3.4 EUT Operating Conditions

The EUT makes a call to the communication simulator. The communication simulator station system controlled a EUT to export maximum output power under transmission mode and specific channel frequency

3.5 General Description of Applied Standards

The EUT is a RF Product. According to the specifications of the manufacturer, it must comply with the requirements of the following standards:

FCC 47 CFR Part 2

FCC 47 CFR Part 27

KDB 971168 D01 Power Meas License Digital Systems v02r02

ANSI/TIA/EIA-603-C 2004

All test items have been performed and recorded as per the above standards.

Note: The EUT has been verified to comply with the requirements of FCC Part 15, Subpart B, Class B (DoC).
The test report has been issued separately.

4 Test Types and Results

4.1 Output Power Measurement

4.1.1 Limits of Output Power Measurement

Mobile / Portable station are limited to 2 watts e.r.p.

4.1.2 Test Procedures

EIRP / ERP Measurement:

- a. All measurements were done at low, middle and high operational frequency range. RBW and VBW is 1MHz for GPRS, EDGE and 5MHz for WCDMA, HSDPA, HSUPA, CDMA mode.
- b. Substitution method is used for E.I.R.P measurement. In the semi-anechoic chamber, EUT placed on the 0.8m height of Turn Table, rotated the table around 360 degrees to search the maximum radiation power and receiver antenna shall be rotated vertical and horizontal polarization and moved height from 1m to 4m to find the maximum polar radiated power. The "Read Value" is the spectrum reading the maximum power value.
- c. The substitution horn antenna is substituted for EUT at the same position and signals generator export the CW signal to the substitution antenna via a TX cable. Rotated the Turn Table and moved receiving antenna to find the maximum radiation power. Adjust output power level of S.G to get a Value of spectrum reading equal to "Read Value" of step b. Record the power level of S.G
- d. $EIRP = \text{Output power level of S.G} - \text{TX cable loss} + \text{Antenna gain of substitution horn}$. E.R.P power can be calculated form E.I.R.P power by subtracting the gain of dipole, $E.R.P \text{ power} = E.I.R.P \text{ power} - 2.15\text{dBi}$.

Conducted Power Measurement:

The EUT was set up for the maximum power with WCDMA, HSDPA, HSUPA link data modulation and link up with simulator. Set the EUT to transmit under low, middle and high channel and record the power level shown on simulator.

4.1.3 Test Setup

EIRP / ERP Measurement:

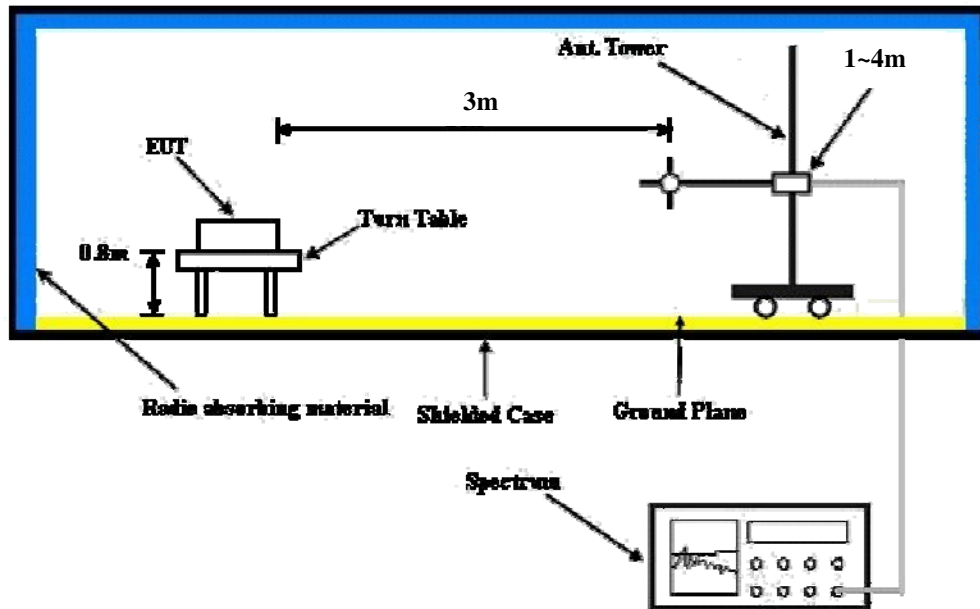

For the actual test configuration, please refer to the attached file (Test Setup Photo).

Conducted Power Measurement:



For the actual test configuration, please refer to the attached file (Test Setup Photo).

4.1.4 Test Results

CONDUCTED OUTPUT POWER (dBm)

Band	WCDMA IV		
	1537	1638	1738
Channel	1712.4	1732.6	1752.6
Frequency (MHz)	1712.4	1732.6	1752.6
RMC 12.2K	22.98	22.97	22.83
HSDPA Subtest-1	22.95	22.95	22.80
HSDPA Subtest-2	22.93	22.94	22.79
HSDPA Subtest-3	22.48	22.49	22.34
HSDPA Subtest-4	22.47	22.49	22.31
HSUPA Subtest-1	22.96	22.95	22.80
HSUPA Subtest-2	20.94	20.91	20.78
HSUPA Subtest-3	21.95	21.93	21.76
HSUPA Subtest-4	20.93	20.89	20.77
HSUPA Subtest-5	22.95	22.93	22.76

EIRP Power (dBm)

WCDMA Band 4 Mode

MODE		TX channel 1312					
Antenna Polarity & Test Distance: Horizontal at 3 M							
No.	Freq. (MHz)	Reading (dBm)	S.G Power Value (dBm)	Correction Factor (dB)	EIRP (dBm)	Limit (dBm)	Margin (dB)
1	1712.40	-20.7	17.8	1.0	18.8	30.0	-11.2
Antenna Polarity & Test Distance: Vertical at 3 M							
No.	Freq. (MHz)	Reading (dBm)	S.G Power Value (dBm)	Correction Factor (dB)	EIRP (dBm)	Limit (dBm)	Margin (dB)
1	1712.40	-19.1	20.1	1.0	21.1	30.0	-8.9

MODE		TX channel 1413					
Antenna Polarity & Test Distance: Horizontal at 3 M							
No.	Freq. (MHz)	Reading (dBm)	S.G Power Value (dBm)	Correction Factor (dB)	EIRP (dBm)	Limit (dBm)	Margin (dB)
1	1732.60	-20.7	18.0	1.0	19.0	30.0	-11.0
Antenna Polarity & Test Distance: Vertical at 3 M							
No.	Freq. (MHz)	Reading (dBm)	S.G Power Value (dBm)	Correction Factor (dB)	EIRP (dBm)	Limit (dBm)	Margin (dB)
1	1732.60	-19.6	19.6	1.0	20.6	30.0	-9.4

MODE		TX channel 1513					
Antenna Polarity & Test Distance: Horizontal at 3 M							
No.	Freq. (MHz)	Reading (dBm)	S.G Power Value (dBm)	Correction Factor (dB)	EIRP (dBm)	Limit (dBm)	Margin (dB)
1	1752.60	-21.2	17.6	1.1	18.7	30.0	-11.3
Antenna Polarity & Test Distance: Vertical at 3 M							
No.	Freq. (MHz)	Reading (dBm)	S.G Power Value (dBm)	Correction Factor (dB)	EIRP (dBm)	Limit (dBm)	Margin (dB)
1	1752.60	-20.0	19.1	1.1	20.2	30.0	-9.8

Note: EIRP (dBm) = S.G Power Value (dBm) + Correction Factor (dB).

4.2 Frequency Stability Measurement

4.2.1 Limits of Frequency Stability Measurement

1.5 ppm is for base and fixed station. 2.5 ppm is for mobile station.

4.2.2 Test Procedure

- Device is placed at the oven room. The oven room could control the temperatures and humidity. Power warm up is at least 15 min and power applied should perform before recording frequency error.
- EUT is connected the external power supply to control the DC input power. The test voltage range is from minimum to maximum working voltage. Each step shall be record the frequency error rate.
- The temperature range step is 10 degrees in this test items. All temperature levels shall be hold the ± 0.5 °C during the measurement testing. The each temperature step shall be at least 0.5 hours, consider the EUT could be test under the stability condition.

Note: The frequency error was recorded frequency error from the communication simulator.

4.2.3 Test Setup

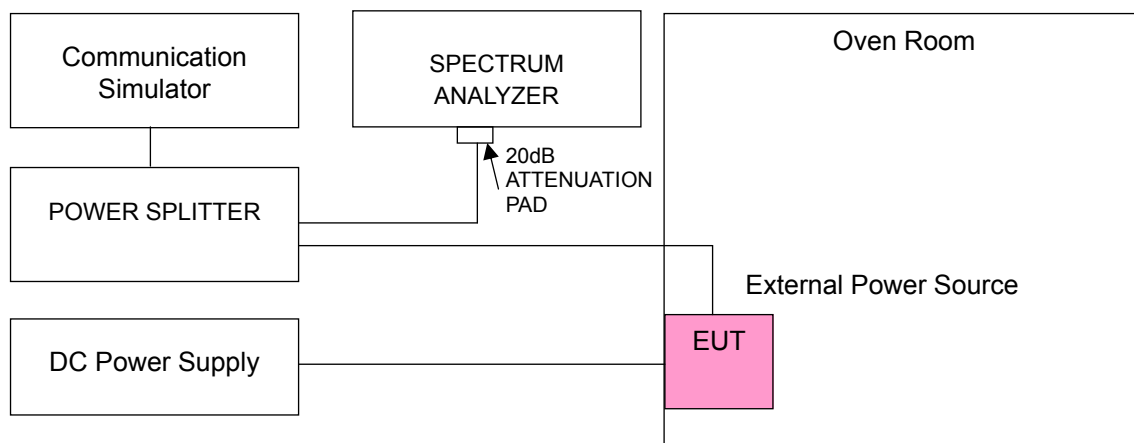

4.2.4 Test Results

Frequency Error vs. Voltage

Voltage (Volts)	Frequency Error (ppm)	Limit (ppm)
26.4	-0.008	2.5
24	-0.006	2.5
21.6	-0.007	2.5

Note: The applicant defined the normal working voltage is from 26.4Vdc to 21.6Vdc.

Frequency Error vs. Temperature.

Temp. (°C)	Frequency Error (ppm)	Limit (ppm)
70	-0.013	2.5
60	-0.012	2.5
50	-0.010	2.5
40	-0.009	2.5
30	-0.008	2.5
20	-0.006	2.5
10	-0.009	2.5
0	-0.010	2.5
-10	-0.011	2.5
-20	-0.013	2.5

4.3 Emission Bandwidth Measurement

4.3.1 Limits of Emission Bandwidth Measurement

According to FCC 27.53(m)(6) specified that emission bandwidth is defined as the width of the signal between two points, one below the carrier center frequency and one above the carrier center frequency, outside of which all emissions are attenuated at least 26dB below the transmitter power.

4.3.2 Test Procedure

The transmitter output was connected to the spectrum analyzer through an attenuator. The bandwidth of the fundamental frequency was measured by spectrum analyzer with RBW = 30kHz and VBW = 100kHz (Channel Bandwidth: 1.4MHz), RBW = 51kHz and VBW = 150kHz (Channel Bandwidth: 3MHz and 5MHz), RBW = 100kHz and VBW = 300kHz (Channel Bandwidth: 10MHz), RBW = 200kHz and VBW = 620kHz (Channel Bandwidth: 15MHz) and RBW = 430kHz and VBW = 1.2MHz (Channel Bandwidth: 20MHz). The 26dB bandwidth is defined as the total spectrum the power of which is higher than peak power minus 26dB.

4.3.3 Test Setup

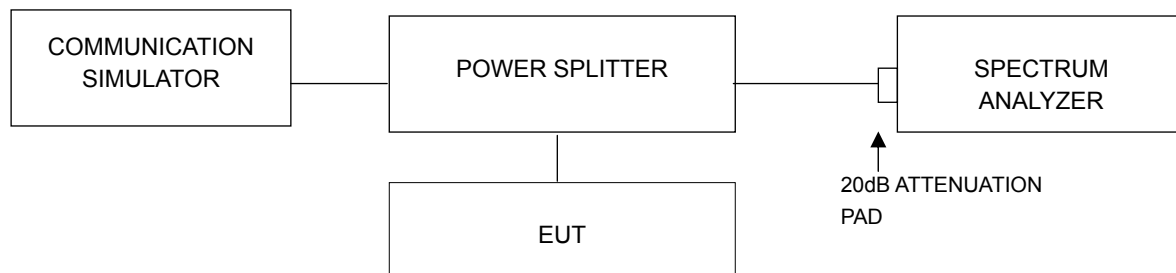

4.3.4 Test Result

Channel	Frequency (MHz)	-26dBc Bandwidth (MHz)			Occupied Bandwidth (MHz)		
		WCDMA	HSDPA	HSUPA	WCDMA	HSDPA	HSUPA
1312	1712.4	4.71	4.68	4.69	4.18	4.17	4.18
1413	1732.6	4.66	4.68	4.68	4.18	4.18	4.18
1513	1752.6	4.65	4.66	4.68	4.17	4.17	4.17

SPECTRUM PLOT OF WORST VALUE

-26dBc Bandwidth

WCDMA

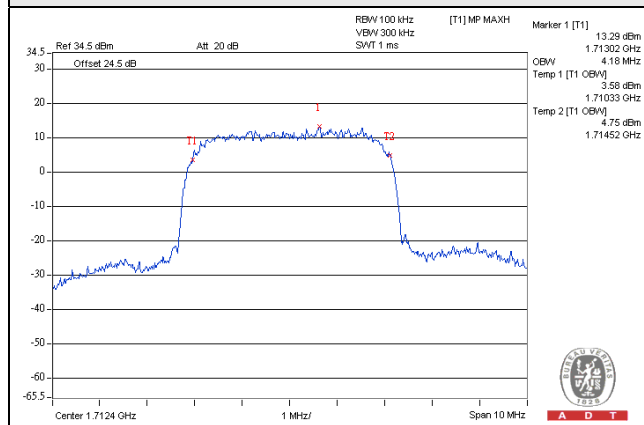

HSDPA

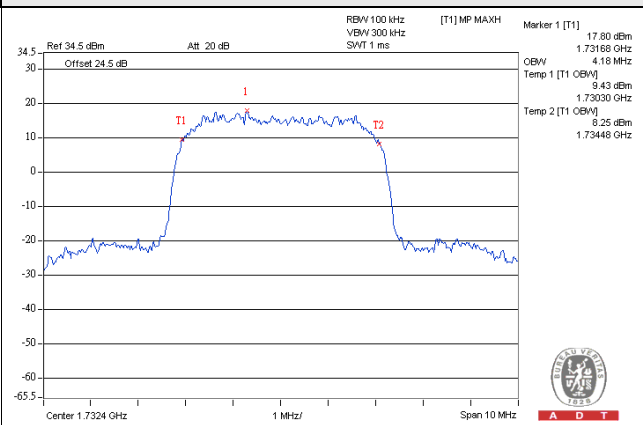

HSUPA

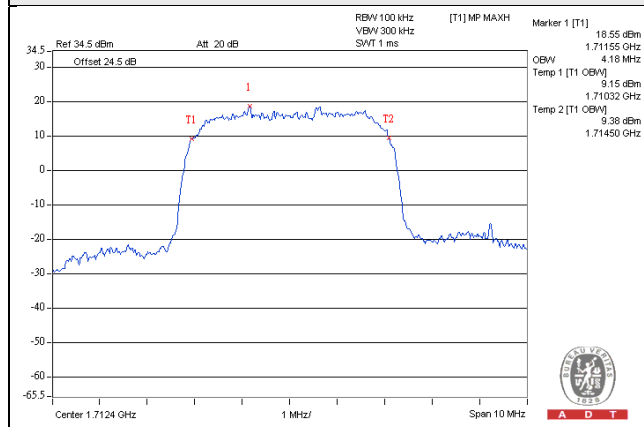

SPECTRUM PLOT OF WORST VALUE

Occupied Bandwidth

WCDMA

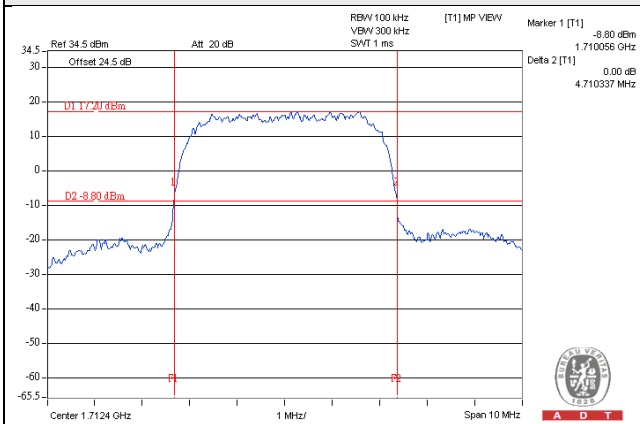

HSDPA

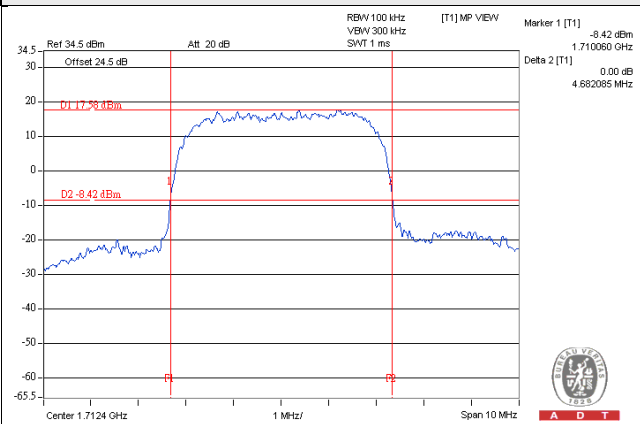

HSUPA

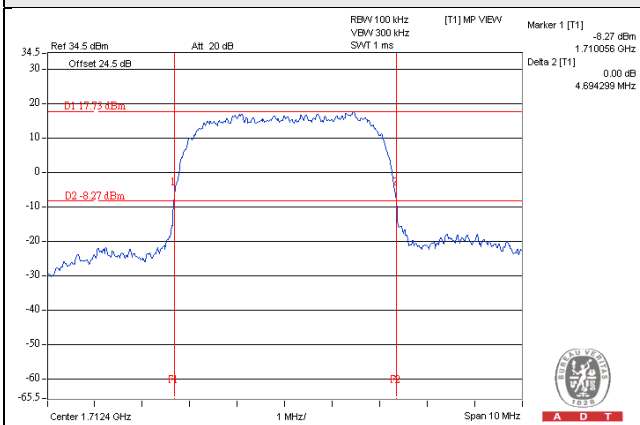

4.4 Channel Edge Measurement

4.4.1 Limits of Band Edge Measurement

According to FCC 27.53(h) for operations in the 1695-1710 MHz, 1710-1755 MHz, 1755-1780 MHz, 1915-1920 MHz, 1995-2000 MHz, 2000-2020 MHz, 2110-2155 MHz, 2155-2180 MHz, and 2180-2200 bands, the power of any emission outside a licensee's frequency block shall be attenuated below the transmitter power (P) in watts by at least $43 + 10 \log_{10}(P)$ dB.

4.4.2 Test Setup

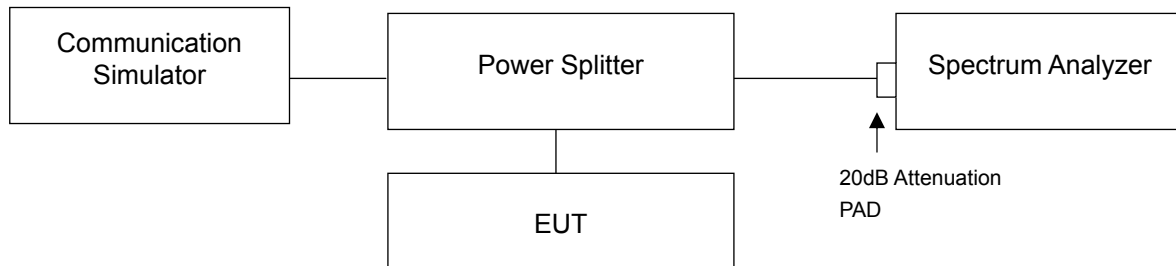

4.4.3 Test Procedures

- a. All measurements were done at low and high operational frequency range.
- b. The center frequency of spectrum is the band edge frequency and span is 10MHz. RB of the spectrum is 100kHz and VB of the spectrum is 300kHz (WCDMA / HSDPA / HSUPA).
- c. Record the max trace plot into the test report.

4.4.4 Test Results

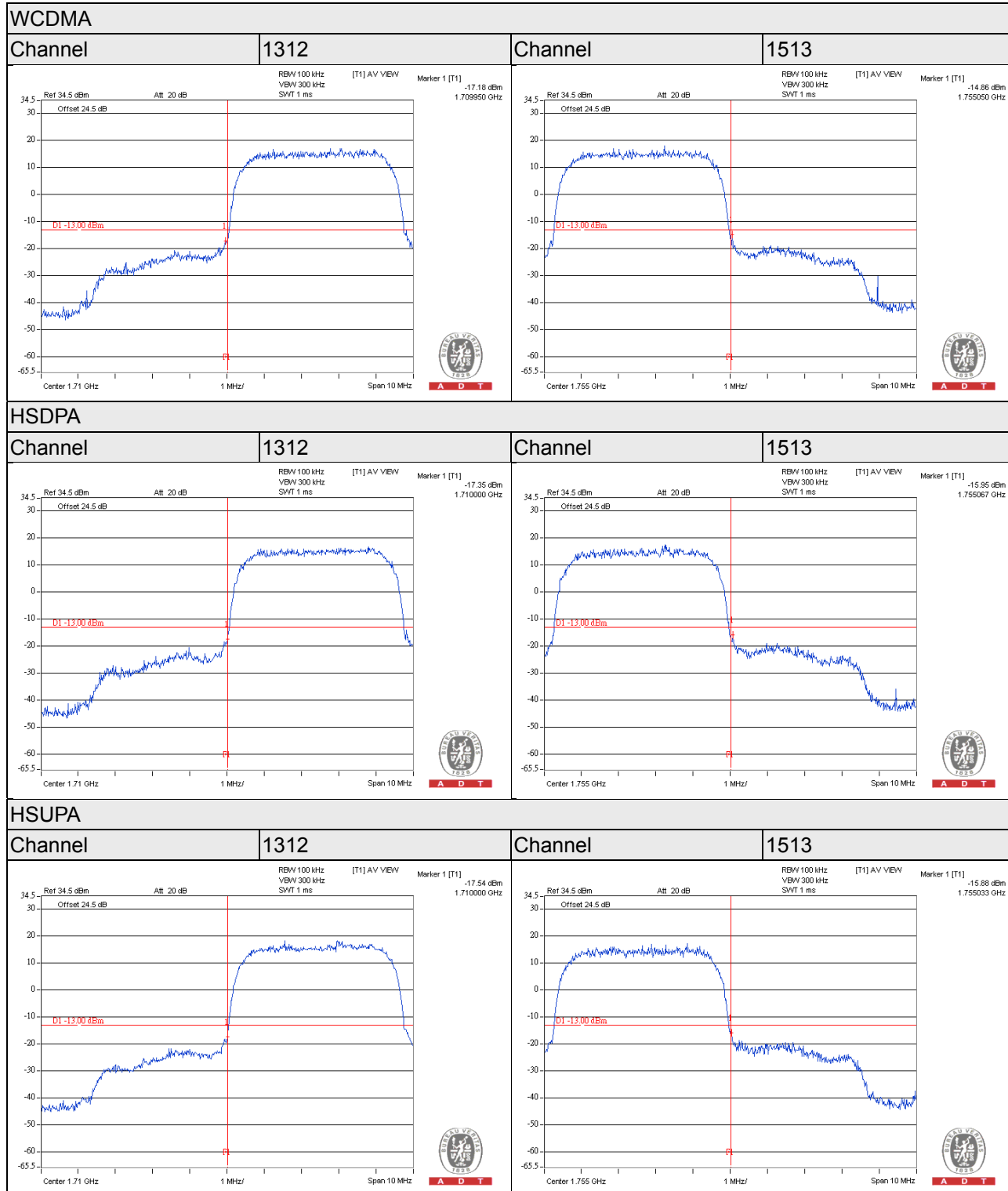

4.5 Peak To Average Ratio

4.5.1 Limits of Peak To Average Ratio Measurement

In measuring transmissions in this band using an average power technique, the peak to-average ratio (PAR) of the transmission may not exceed 13 dB

4.5.2 Test Setup

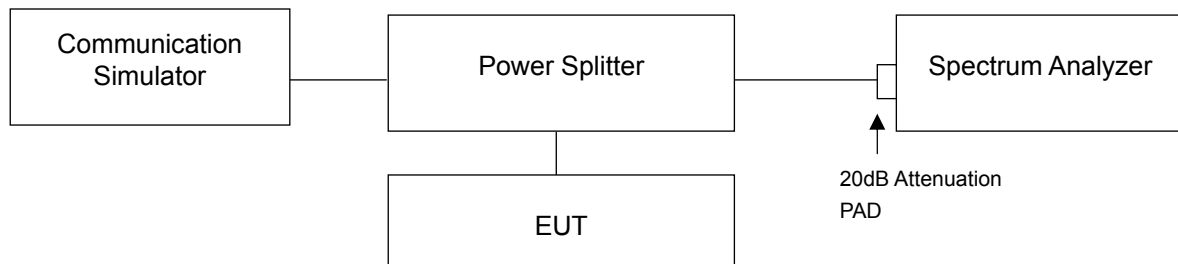

4.5.3 Test Procedures

- Set resolution/measurement bandwidth \geq signal's occupied bandwidth;
- Set the number of counts to a value that stabilizes the measured CCDF curve;
- Record the maximum PAPR level associated with a probability of 0.1%.

4.5.4 Test Results

Channel	Frequency (MHz)	Peak To Average Ratio (dB)		
		WCDMA	HSDPA	HSUPA
1312	1712.4	3.41	3.40	3.43
1413	1732.6	3.38	3.45	3.40
1513	1752.6	3.50	3.52	3.53

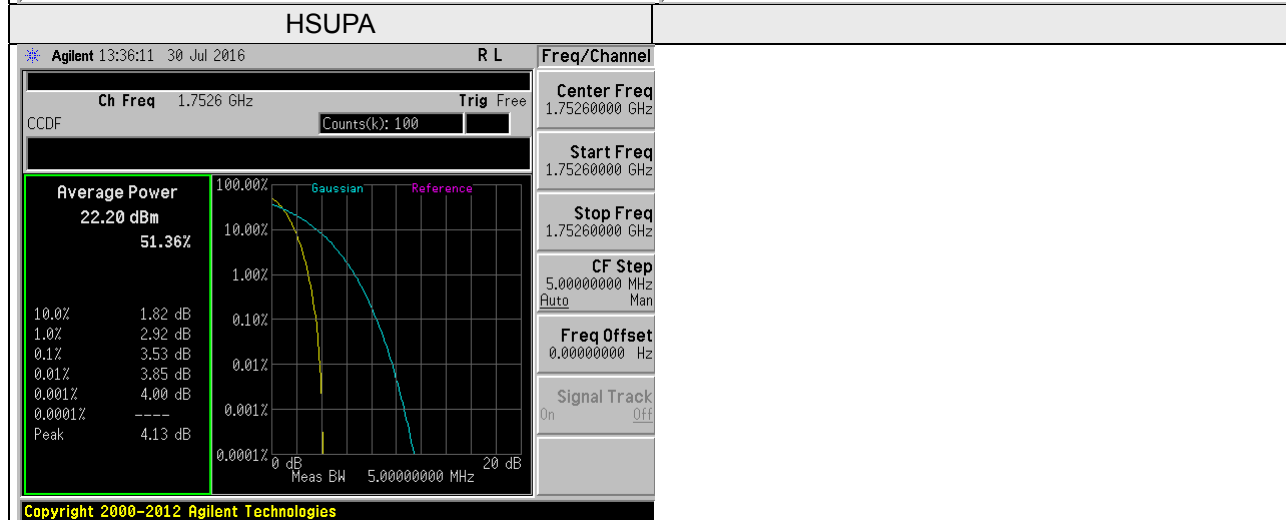
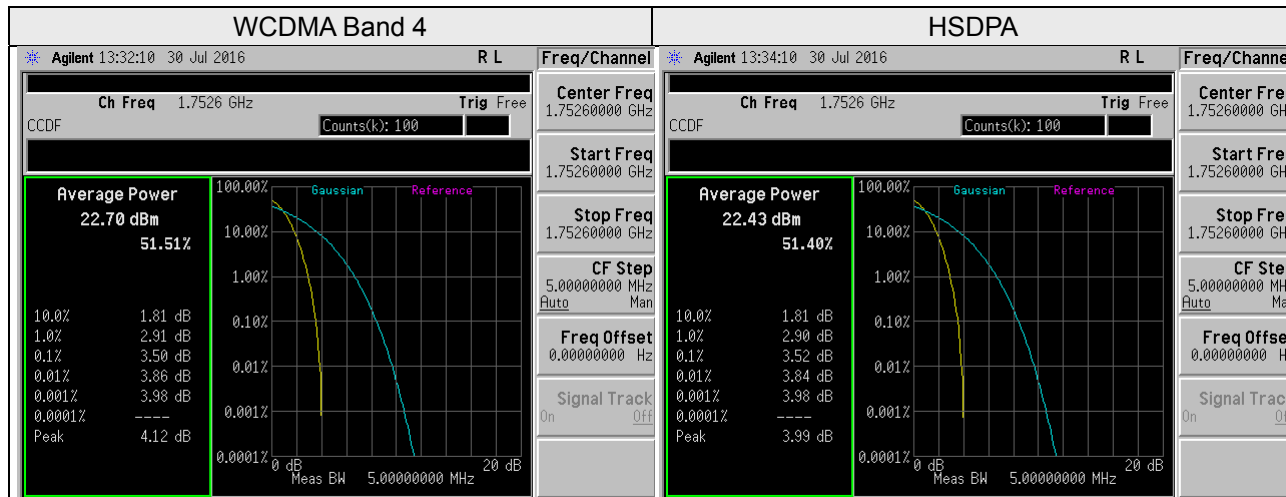

4.6 Conducted Spurious Emissions

4.6.1 Limits of Conducted Spurious Emissions Measurement

According to FCC 27.53(h) for operations in the 1695-1710 MHz, 1710-1755 MHz, 1755-1780 MHz, 1915-1920 MHz, 1995-2000 MHz, 2000-2020 MHz, 2110-2155 MHz, 2155-2180 MHz, and 2180-2200 bands, the power of any emission outside a licensee's frequency block shall be attenuated below the transmitter power (P) in watts by at least $43 + 10 \log_{10}(P)$ dB.

4.6.2 Test Setup

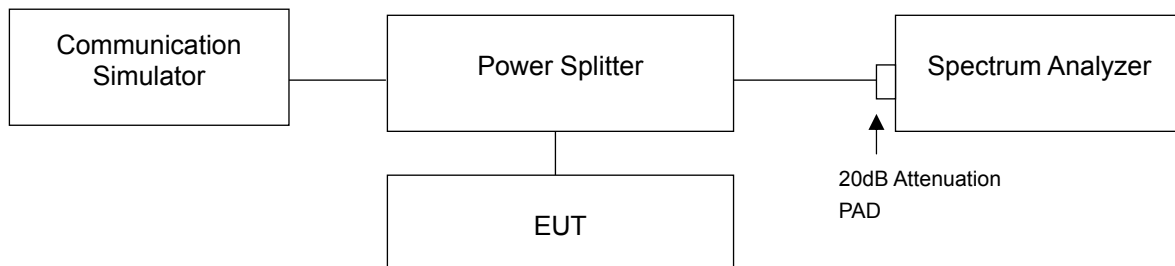

4.6.3 Test Procedure

- The EUT makes a phone call to the communication simulator. All measurements were done at low, middle and high operational frequency range.
- Measuring frequency range is from 9 kHz to 20GHz. 20dB attenuation pad is connected with spectrum. RBW=1MHz and VBW=3MHz is used for conducted emission measurement.

4.6.4 Test Results

WCDMA

Channel 1312

Frequency Range : 9kHz~3GHz

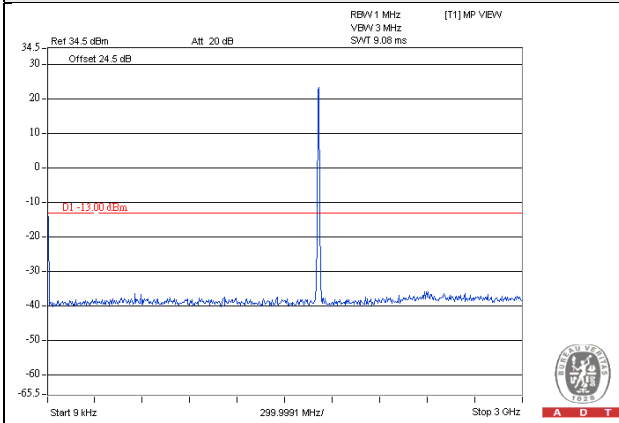

Frequency Range : 3GHz~10GHz

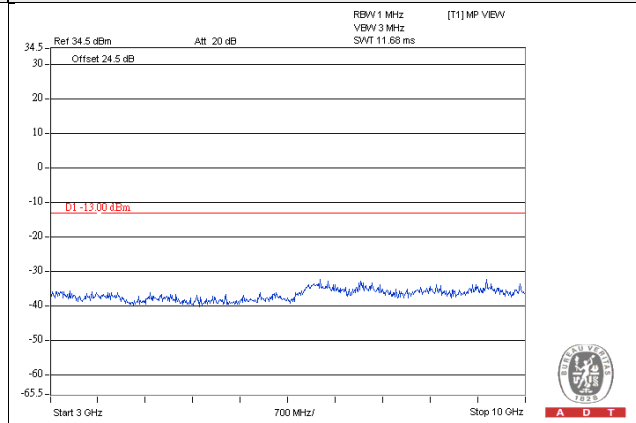

Frequency Range : 10GHz~20GHz

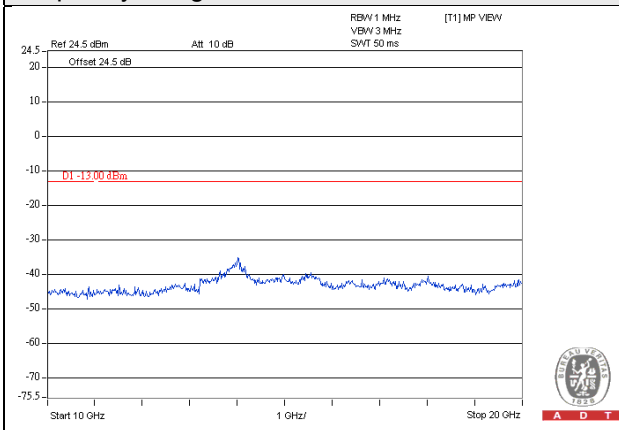

WCDMA

Channel 1413

Frequency Range : 9kHz~3GHz

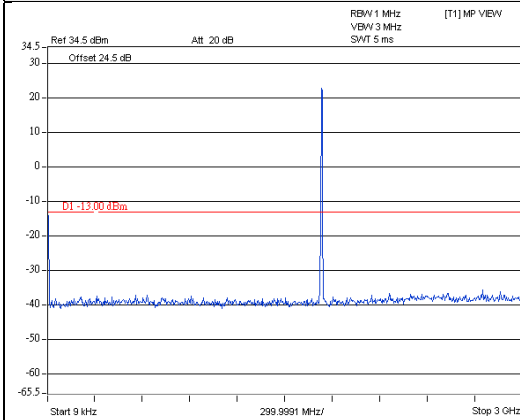

Frequency Range : 3GHz~10GHz

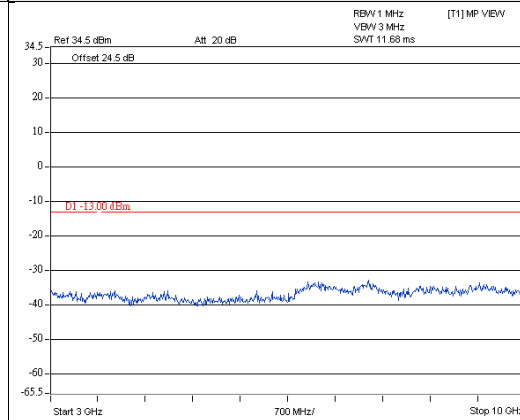

Frequency Range : 10GHz~20GHz

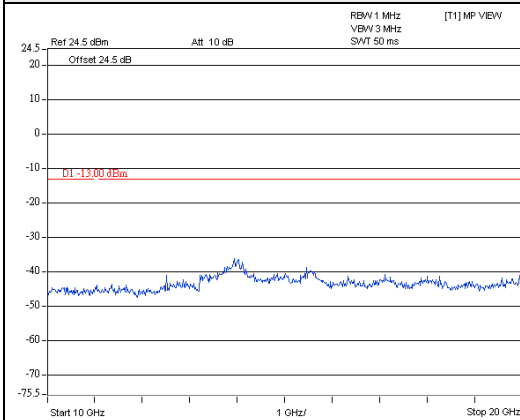

WCDMA

Channel 1513

Frequency Range : 9kHz~3GHz

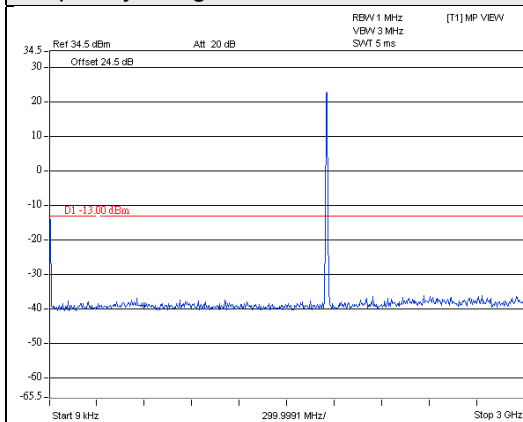

Frequency Range : 3GHz~10GHz

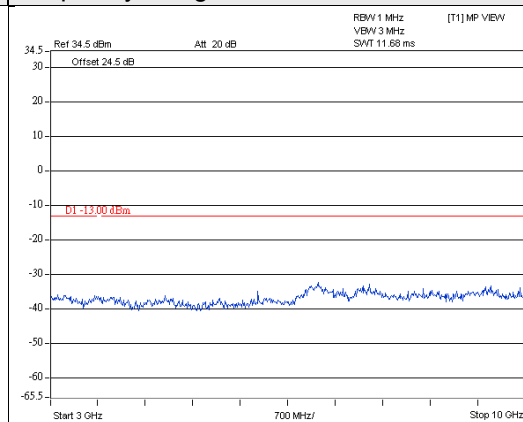

Frequency Range : 10GHz~20GHz

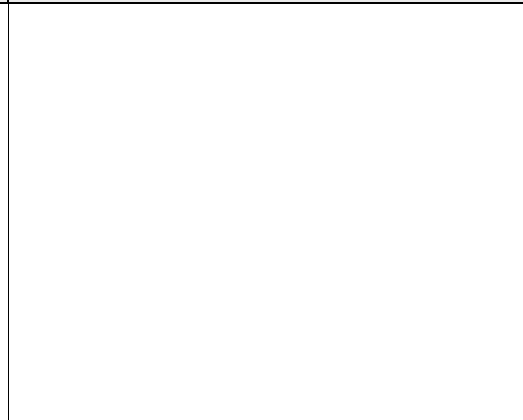
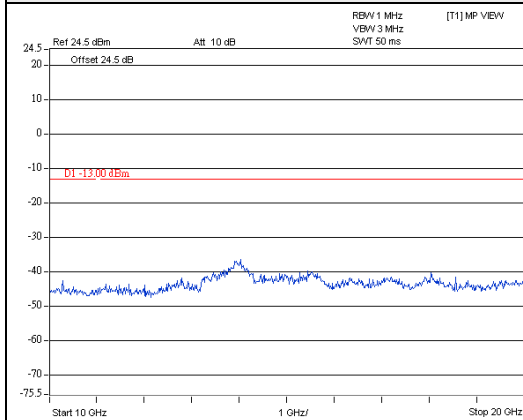

HSDPA

Channel 1312

Frequency Range : 9kHz~3GHz

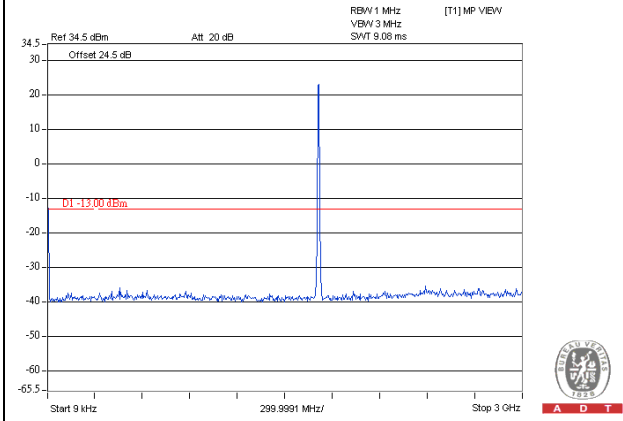

Frequency Range : 3GHz~10GHz

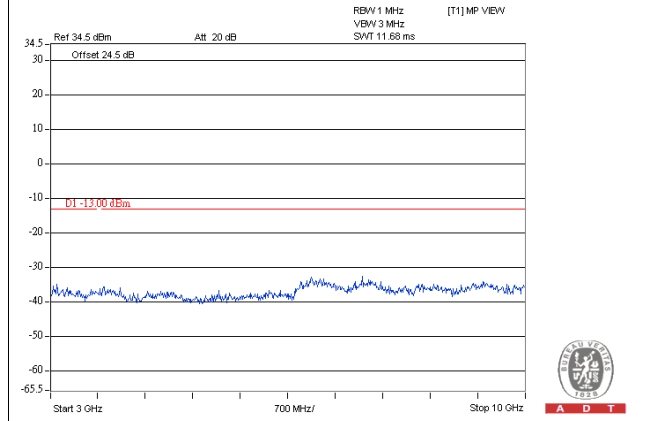

Frequency Range : 10GHz~20GHz

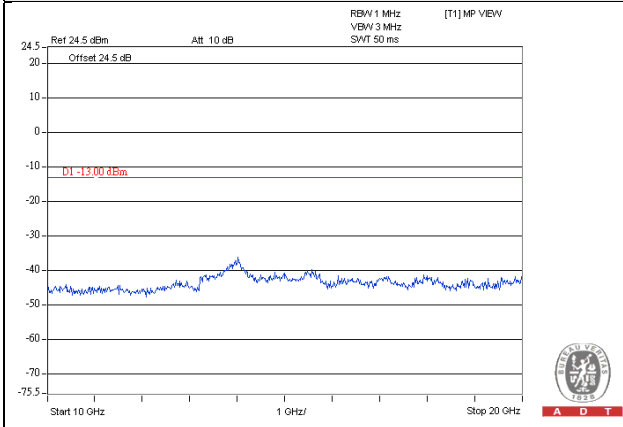

HSDPA

Channel 1413

Frequency Range : 9kHz~3GHz

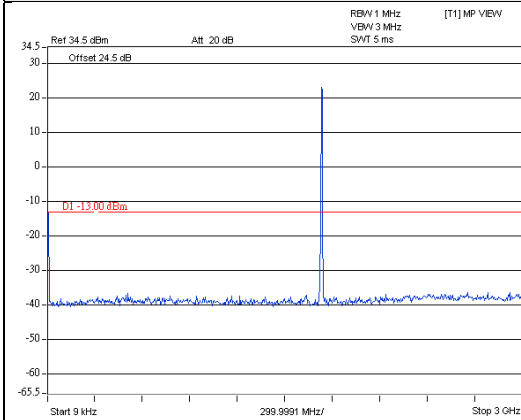

Frequency Range : 3GHz~10GHz

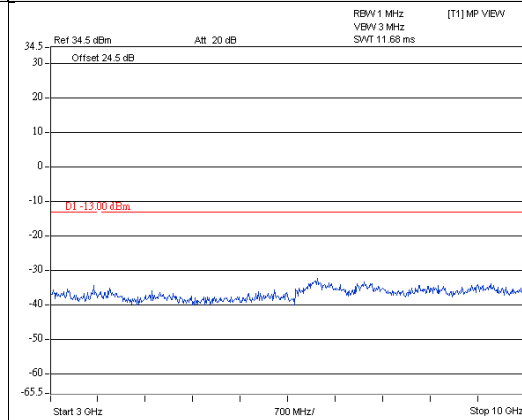

Frequency Range : 10GHz~20GHz

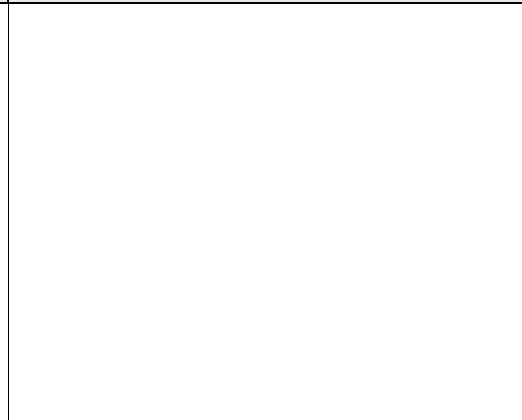
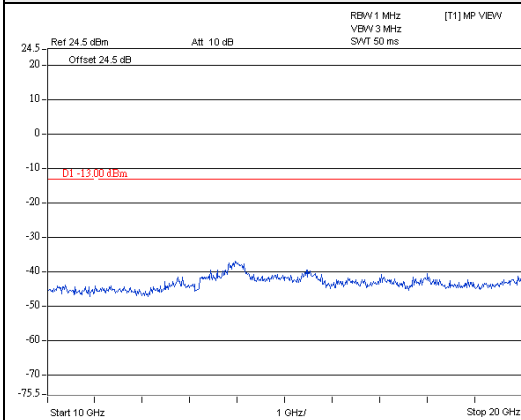

HSDPA

Channel 1513

Frequency Range : 9kHz~3GHz

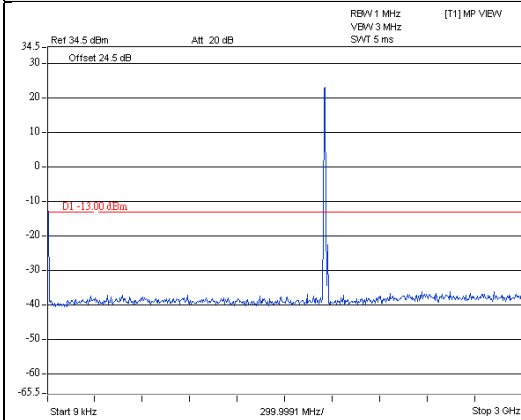

Frequency Range : 3GHz~10GHz

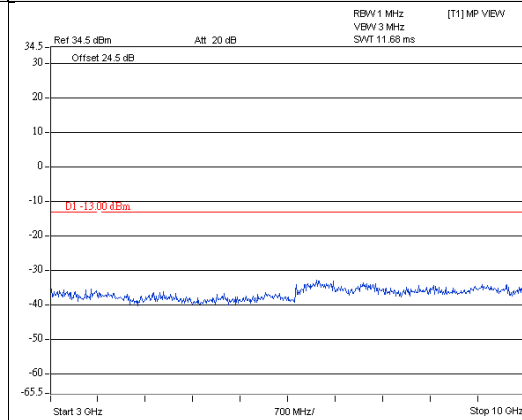

Frequency Range : 10GHz~20GHz

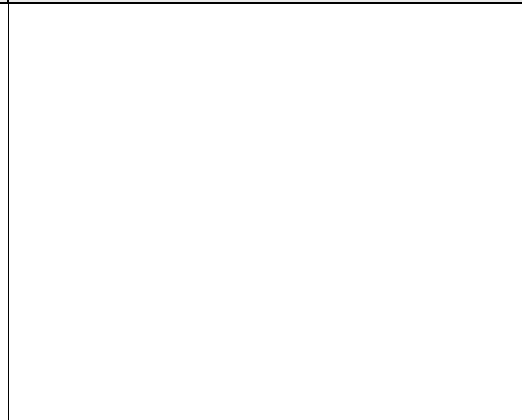
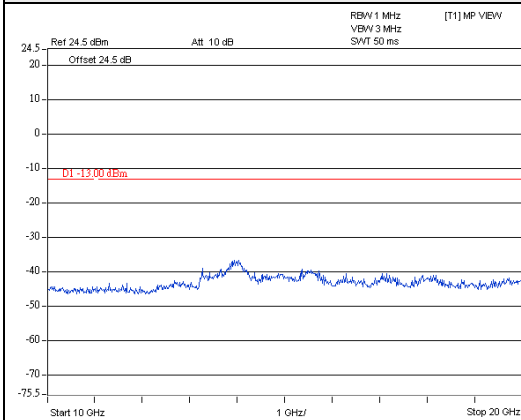

HSUPA

Channel 1312

Frequency Range : 9kHz~3GHz

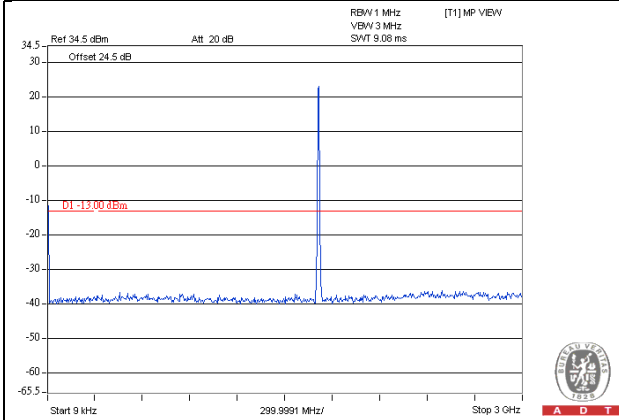

Frequency Range : 3GHz~10GHz

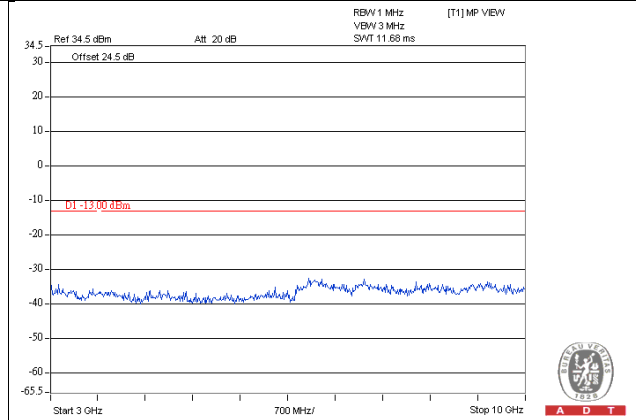

Frequency Range : 10GHz~20GHz

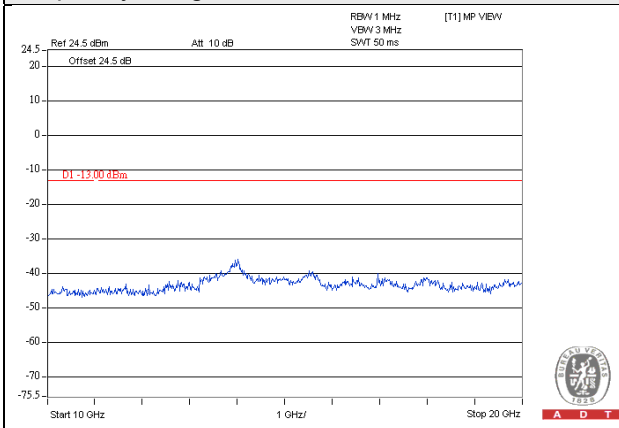

HSUPA

Channel 1413

Frequency Range : 9kHz~3GHz

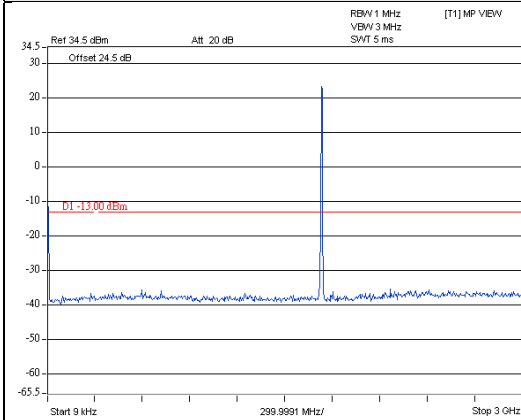

Frequency Range : 3GHz~10GHz

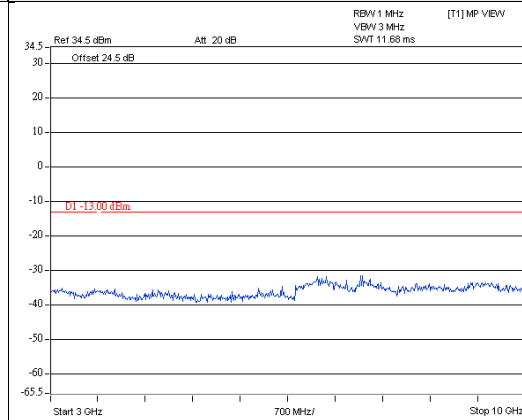

Frequency Range : 10GHz~20GHz

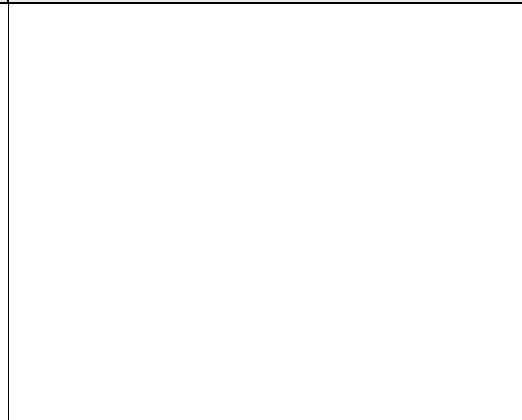
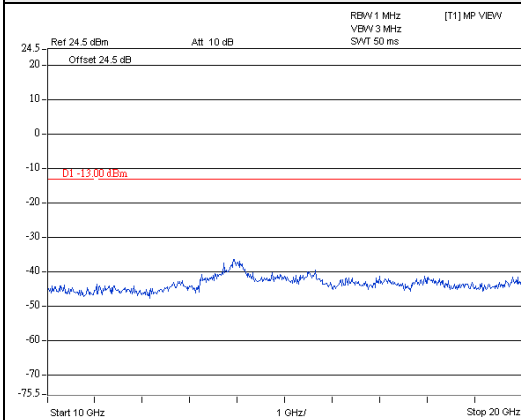

HSUPA

Channel 1513

Frequency Range : 9kHz~3GHz

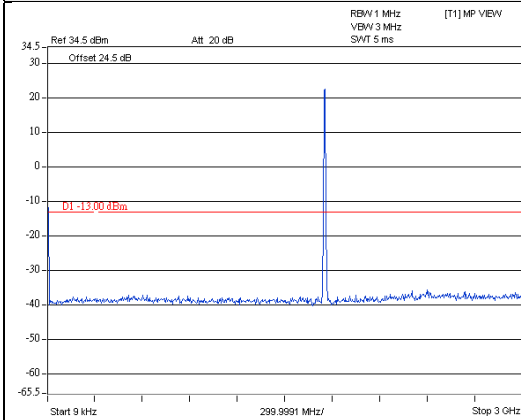

Frequency Range : 3GHz~10GHz

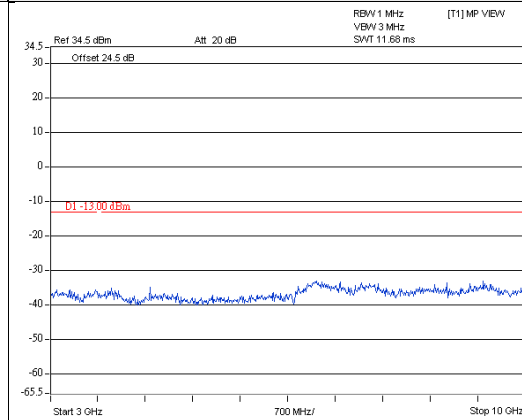

Frequency Range : 10GHz~20GHz

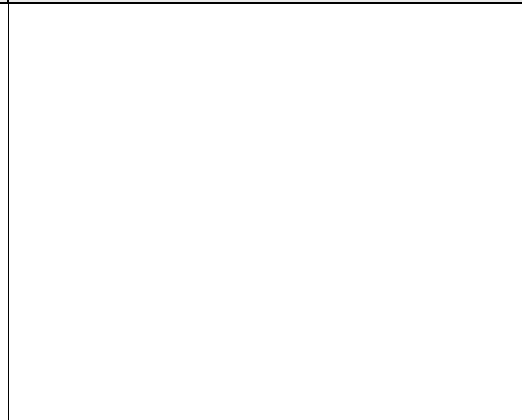
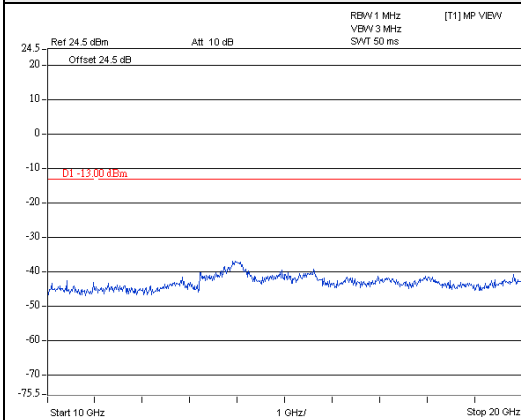

4.7 Radiated Emission Measurement

4.7.1 Limits of Radiated Emission Measurement

According to FCC 27.53(h) for operations in the 1695-1710 MHz, 1710-1755 MHz, 1755-1780 MHz, 1915-1920 MHz, 1995-2000 MHz, 2000-2020 MHz, 2110-2155 MHz, 2155-2180 MHz, and 2180-2200 bands, the power of any emission outside a licensee's frequency block shall be attenuated below the transmitter power (P) in watts by at least $43 + 10 \log_{10}(P)$ dB.

4.7.2 Test Procedure

- a. Substitution method is used for E.I.R.P measurement. In the semi-anechoic chamber, EUT placed on the 0.8m height of Turn Table, rotated the table around 360 degrees to search the maximum radiation power and receiver antenna shall be rotated vertical and horizontal polarization and moved height from 1m to 4m to find the maximum polar radiated power. The "Read Value" is the spectrum reading the maximum power value.
- b. The substitution horn antenna is substituted for EUT at the same position and signals generator export the CW signal to the substitution antenna via a TX cable. Rotated the Turn Table and moved receiving antenna to find the maximum radiation power. Adjust output power level of S.G to get a Value of spectrum reading equal to "Read Value" of step a. Record the power level of S.G
- c. $EIRP = \text{Output power level of S.G} - \text{TX cable loss} + \text{Antenna gain of substitution horn.}$
- d. E.R.P power can be calculated form E.I.R.P power by subtracting the gain of dipole, $E.R.P \text{ power} = E.I.R.P \text{ power} - 2.15\text{dBi.}$

NOTE: The resolution bandwidth and video bandwidth of test receiver/spectrum analyzer is 1MHz/3MHz.

4.7.3 Deviation from Test Standard

No deviation.

4.7.4 Test Setup

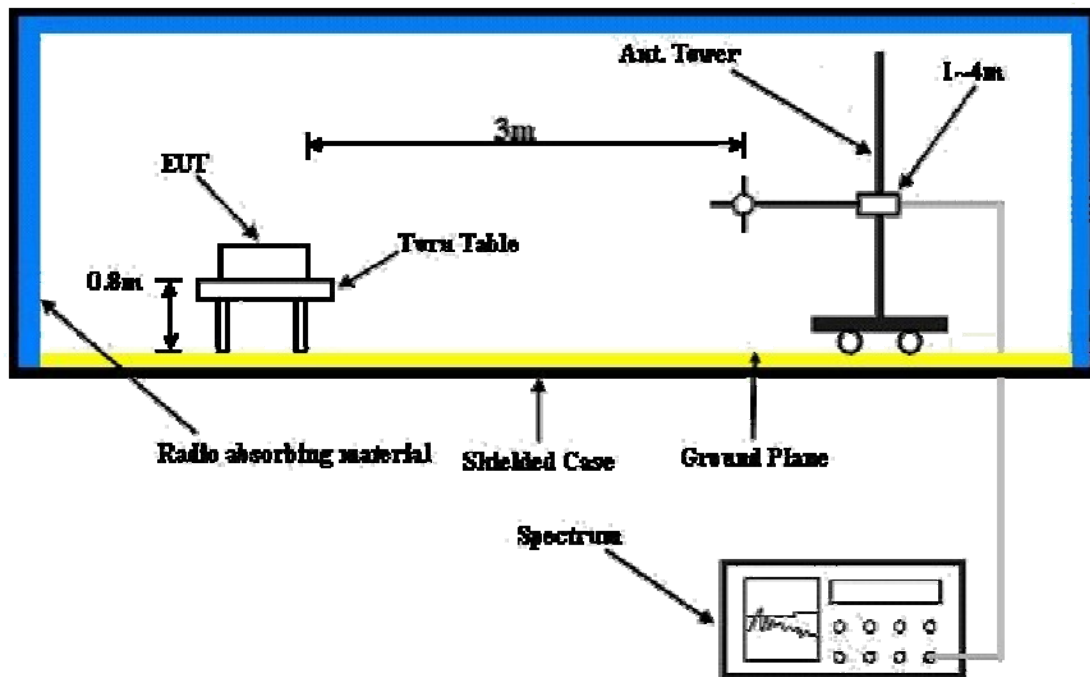

For the actual test configuration, please refer to the attached file (Test Setup Photo).

4.7.5 Test Results

Below 1GHz

Mode	TX channel 1312	Frequency Range	Below 1000 MHz
Environmental Conditions	24deg. C, 68%RH	Input Power	120Vac, 60Hz
Tested By	Alan Wu		

Antenna Polarity & Test Distance: Horizontal at 3 M							
No.	Freq. (MHz)	Reading (dBm)	S.G Power Value (dBm)	Correction Factor (dB)	EIRP (dBm)	Limit (dBm)	Margin (dB)
1	80.44	-49.1	-53.4	-1.6	-55.0	-13.0	-42.0
2	125.06	-54.8	-61.9	0.0	-61.9	-13.0	-48.9
3	317.12	-56.0	-65.5	5.2	-60.3	-13.0	-47.3
4	652.74	-54.9	-58.3	4.8	-53.5	-13.0	-40.5
5	780.78	-62.0	-61.0	4.2	-56.8	-13.0	-43.8
6	935.98	-64.7	-61.6	3.9	-57.7	-13.0	-44.7
Antenna Polarity & Test Distance: Vertical at 3 M							
No.	Freq. (MHz)	Reading (dBm)	S.G Power Value (dBm)	Correction Factor (dB)	EIRP (dBm)	Limit (dBm)	Margin (dB)
1	80.44	-52.8	-54.8	-1.6	-56.4	-13.0	-43.4
2	130.88	-52.4	-57.5	-0.1	-57.6	-13.0	-44.6
3	233.70	-61.8	-67.2	5.4	-61.8	-13.0	-48.8
4	319.06	-60.2	-66.4	5.2	-61.2	-13.0	-48.2
5	676.02	-61.3	-61.4	5.1	-56.3	-13.0	-43.3
6	780.78	-64.4	-62.3	4.2	-58.1	-13.0	-45.1

Remarks:

1. Output Power (dBm) = S.G Value (dBm) + Correction Factor (dB).
2. Correction Factor (dB) = Substitution Antenna Gain (dB) + Cable Loss (dB).

Above 1GHz

Mode	TX channel 1312	Frequency Range	Above 1000MHz
Environmental Conditions	24deg. C, 64%RH	Input Power	120Vac, 60Hz
Tested By	Chris Lin		

Antenna Polarity & Test Distance: Horizontal at 3 M							
No.	Freq. (MHz)	Reading (dBm)	S.G Power Value (dBm)	Correction Factor (dB)	EIRP (dBm)	Limit (dBm)	Margin (dB)
1	3424.80	-59.7	-55.5	7.1	-48.4	-13.0	-35.4
2	5137.20	-71.4	-59.5	6.6	-52.9	-13.0	-39.9
3	6849.60	-70.8	-53.1	5.0	-48.1	-13.0	-35.1
Antenna Polarity & Test Distance: Vertical at 3 M							
No.	Freq. (MHz)	Reading (dBm)	S.G Power Value (dBm)	Correction Factor (dB)	EIRP (dBm)	Limit (dBm)	Margin (dB)
1	3424.80	-61.8	-55.3	7.1	-48.2	-13.0	-35.2
2	5137.20	-69.8	-59.2	6.6	-52.6	-13.0	-39.6
3	6849.60	-70.9	-54.4	5.0	-49.4	-13.0	-36.4

Remarks:

1. Output Power (dBm) = S.G Value (dBm) + Correction Factor (dB).
2. Correction Factor (dB) = Substitution Antenna Gain (dB) + Cable Loss (dB).

Mode	TX channel 1413	Frequency Range	Above 1000MHz
Environmental Conditions	24deg. C, 64%RH	Input Power	120Vac, 60Hz
Tested By	Chris Lin		

Antenna Polarity & Test Distance: Horizontal at 3 M							
No.	Freq. (MHz)	Reading (dBm)	S.G Power Value (dBm)	Correction Factor (dB)	EIRP (dBm)	Limit (dBm)	Margin (dB)
1	3465.20	-59.5	-54.6	7.1	-47.5	-13.0	-34.5
2	5197.80	-70.4	-58.3	6.7	-51.6	-13.0	-38.6
3	6930.40	-71.0	-52.5	4.8	-47.7	-13.0	-34.7
Antenna Polarity & Test Distance: Vertical at 3 M							
No.	Freq. (MHz)	Reading (dBm)	S.G Power Value (dBm)	Correction Factor (dB)	EIRP (dBm)	Limit (dBm)	Margin (dB)
1	3465.20	-61.2	-54.4	7.1	-47.3	-13.0	-34.3
2	5197.80	-70.2	-60.1	6.7	-53.4	-13.0	-40.4
3	6930.40	-71.0	-53.3	4.8	-48.5	-13.0	-35.5

Remarks:

1. Output Power (dBm) = S.G Value (dBm) + Correction Factor (dB).
2. Correction Factor (dB) = Substitution Antenna Gain (dB) + Cable Loss (dB).

Mode	TX channel 1513	Frequency Range	Above 1000MHz
Environmental Conditions	24deg. C, 64%RH	Input Power	120Vac, 60Hz
Tested By	Chris Lin		

Antenna Polarity & Test Distance: Horizontal at 3 M							
No.	Freq. (MHz)	Reading (dBm)	S.G Power Value (dBm)	Correction Factor (dB)	EIRP (dBm)	Limit (dBm)	Margin (dB)
1	3505.20	-58.2	-52.7	7.2	-45.5	-13.0	-32.5
2	5257.80	-65.2	-53.6	6.7	-46.9	-13.0	-33.9
3	7010.40	-70.5	-51.5	4.7	-46.8	-13.0	-33.8
Antenna Polarity & Test Distance: Vertical at 3 M							
No.	Freq. (MHz)	Reading (dBm)	S.G Power Value (dBm)	Correction Factor (dB)	EIRP (dBm)	Limit (dBm)	Margin (dB)
1	3505.20	-56.7	-49.7	7.2	-42.5	-13.0	-29.5
2	5257.80	-64.9	-54.1	6.7	-47.4	-13.0	-34.4
3	7010.40	-71.0	-52.4	4.7	-47.7	-13.0	-34.7

Remarks:

1. Output Power (dBm) = S.G Value (dBm) + Correction Factor (dB).
2. Correction Factor (dB) = Substitution Antenna Gain (dB) + Cable Loss (dB).

5 Pictures of Test Arrangements

Please refer to the attached file (Test Setup Photo).

Appendix – Information on the Testing Laboratories

We, Bureau Veritas Consumer Products Services (H.K.) Ltd., Taoyuan Branch, were founded in 1988 to provide our best service in EMC, Radio, Telecom and Safety consultation. Our laboratories are accredited and approved according to ISO/IEC 17025.

If you have any comments, please feel free to contact us at the following:

Linko EMC/RF Lab

Tel: 886-2-26052180

Fax: 886-2-26051924

Hsin Chu EMC/RF/Telecom Lab

Tel: 886-3-6668565

Fax: 886-3-6668323

Hwa Ya EMC/RF/Safety Lab

Tel: 886-3-3183232

Fax: 886-3-3270892

Email: service.adt@tw.bureauveritas.com

Web Site: www.bureauveritas-adt.com

The address and road map of all our labs can be found in our web site also.

--- END ---