

FCC 47 CFR PART 15 SUBPART C

TEST REPORT

For

Computer

Model:

TREK-688, TREK-688XXXXXXXXXXXXXXXXXX (where "X" may be any alphanumeric character , "-" or blank)

Trade Name: ADVANTECH

Issued to

Advantech Co. Ltd.

No.1, Alley 20, Lane 26, Rueiguang Road, Neihu District, Taipei 114, Taiwan, R.O.C.

Issued by

Compliance Certification Services Inc.

**No.11, Wugong 6th Rd., Wugu Dist.,
New Taipei City 24891, Taiwan. (R.O.C.)**

<http://www.ccsrf.com>

service@ccsrf.com

Issued Date: January 6, 2016



Note: This report shall not be reproduced except in full, without the written approval of Compliance Certification Services Inc. This document may be altered or revised by Compliance Certification Services Inc. personnel only, and shall be noted in the revision section of the document.

Revision History

Rev.	Issue Date	Revisions	Effect Page	Revised By
00	January 6, 2016	Initial Issue	ALL	Doris Chu

TABLE OF CONTENTS

1. TEST RESULT CERTIFICATION	4
2. EUT DESCRIPTION.....	5
3. TEST METHODOLOGY.....	6
3.1 EUT CONFIGURATION	6
3.2 EUT EXERCISE	6
3.3 GENERAL TEST PROCEDURES.....	6
3.4 FCC PART 15.205 RESTRICTED BANDS OF OPERATIONS	7
3.5 DESCRIPTION OF TEST MODES.....	8
4. INSTRUMENT CALIBRATION	9
4.1 MEASURING INSTRUMENT CALIBRATION	9
4.2 MEASUREMENT EQUIPMENT USED	9
4.3 MEASUREMENT UNCERTAINTY	10
5. FACILITIES AND ACCREDITATIONS	11
5.1 FACILITIES	11
5.2 EQUIPMENT	11
5.3 TABLE OF ACCREDITATIONS AND LISTINGS.....	12
6. SETUP OF EQUIPMENT UNDER TEST	13
6.1 SETUP CONFIGURATION OF EUT	13
6.2 SUPPORT EQUIPMENT.....	13
7. FCC PART 15.247 REQUIREMENTS	14
7.1 6DB BANDWIDTH.....	14
7.2 PEAK POWER	24
7.3 AVERAGE POWER	26
7.4 BAND EDGES MEASUREMENT	28
7.5 PEAK POWER SPECTRAL DENSITY	50
7.6 RADIATED EMISSIONS	60
7.7 POWERLINE CONDUCTED EMISSIONS.....	102
APPENDIX I PHOTOGRAPHS OF TEST SETUP	103
APPENDIX 1 - PHOTOGRAPHS OF EUT	

1. TEST RESULT CERTIFICATION

Applicant: Advantech Co. Ltd.
No.1, Alley 20, Lane 26, Rueiguang Road, Neihu District,
Taipei 114, Taiwan, R.O.C.

Equipment Under Test: Computer

Trade Name: ADVANTECH

Model: TREK-688, TREK-688XXXXXXXXXXXXXXXXXX (where "X" may be any alphanumeric character, "-" or blank)

Date of Test: November 10 ~ December 18, 2015

APPLICABLE STANDARDS	
STANDARD	TEST RESULT
FCC 47 CFR Part 15 Subpart C	No non-compliance noted

We hereby certify that:

The above equipment was tested by Compliance Certification Services Inc. The test data, data evaluation, test procedures, and equipment configurations shown in this report were made in accordance with the procedures given in ANSI C63.10: 2013 and the energy emitted by the sample EUT tested as described in this report is in compliance with the requirements of FCC Rules Part 15.203, 15.207, 15.209, 15.247.

The test results of this report relate only to the tested sample EUT identified in this report.

Approved by:

Reviewed by:



Miller Lee
Manager
Compliance Certification Services Inc.

Angel Cheng
Section Manager
Compliance Certification Services Inc.

2. EUT DESCRIPTION

Product	Computer
Trade Name	ADVANTECH
Model Number	TREK-688, TREK-688XXXXXXXXXXXXXXXXXX (where "X" may be any alphanumeric character , "-" or blank)
Model Discrepancy	All the above models are identical except for the designation of model numbers. The suffix of (where "X" may be any alphanumeric character , "-" or blank) on model number is just for marketing purpose only.
Received Date	October 5, 2015
Power Rating	Supports 12/24 V car power system (9V ~ 32V wide DC input)
Frequency Range	2412 ~ 2462 MHz
Transmit Power	IEEE 802.11b mode: 22.92 dBm IEEE 802.11g mode: 24.68 dBm IEEE 802.11n HT 20 MHz mode: 24.42 dBm IEEE 802.11n HT 40 MHz mode: 22.02 dBm
Modulation Technique	IEEE 802.11b mode: DSSS (1, 2, 5.5 and 11 Mbps) IEEE 802.11g mode: OFDM (6, 9, 12, 18, 24, 36, 48 and 54 Mbps) IEEE 802.11n HT 20 MHz mode: OFDM (6.5, 7.2, 13, 14.4, 14.44, 19.5, 21.7, 26, 28.89, 28.9, 39, 43.3, 43.33, 52, 57.78, 57.8, 58.5, 65.0, 72.2, 78, 86.67, 104, 115.56, 117, 130, 144.44 Mbps) IEEE 802.11n HT 40 MHz mode: OFDM (13.5, 27, 40.5, 54, 81, 108, 121.5, 135Mbps)
Number of Channels	IEEE 802.11b/g mode: 11 Channels IEEE 802.11n HT 20 MHz mode: 11 Channels IEEE 802.11n HT 40 MHz mode: 7 Channels
Antenna Specification	WIESON / GPOT113-020 Gain: -0.79 dBi
Antenna Designation	Dipole Antenna

Remark:

1. The sample selected for test was engineering sample that approximated to production product and was provided by manufacturer.
2. This submittal(s) (test report) is intended for FCC ID: **M82-TREK688LTE** filing to comply with Section 15.203, 15.207, 15.209 and 15.247 of the FCC Part 15, Subpart C Rules.

3. TEST METHODOLOGY

The tests documented in this report were performed in accordance with ANSI C63.10: 2013 and FCC CFR 47 Part 15.203, 15.207, 15.209, 15.247, KDB558074.

3.1 EUT CONFIGURATION

The EUT configuration for testing is installed on RF field strength measurement to meet the Commissions requirement and operating in a manner that intends to maximize its emission characteristics in a continuous normal application.

3.2 EUT EXERCISE

The EUT was operated in the engineering mode to fix the TX frequency that was for the purpose of the measurements.

According to its specifications, the EUT must comply with the requirements of the Section 15.207, 15.209 and 15.247 under the FCC Rules Part 15 Subpart C.

3.3 GENERAL TEST PROCEDURES

Conducted Emissions

According to the requirements in ANSI C63.10: 2013 Conducted emissions from the EUT measured in the frequency range between 0.15 MHz and 30MHz using CISPR Quasi-peak and average detector modes.

Radiated Emissions

The EUT is placed on a turn table, which is 1.5 m above ground plane. The turntable shall rotate 360 degrees to determine the position of maximum emission level. EUT is set 3m away from the receiving antenna, which varied from 1m to 4m to find out the highest emission. And also, each emission was to be maximized by changing the polarization of receiving antenna both horizontal and vertical. In order to find out the maximum emissions, exploratory radiated emission measurements were made according to the requirements in ANSI C63.10: 2013.

3.4 FCC PART 15.205 RESTRICTED BANDS OF OPERATIONS

(a) Except as shown in paragraph (d) of this section, only spurious emissions are permitted in any of the frequency bands listed below:

MHz	MHz	MHz	GHz
0.090 - 0.110	16.42 - 16.423	399.9 - 410	4.5 - 5.15
¹ 0.495 - 0.505	16.69475 - 16.69525	608 - 614	5.35 - 5.46
2.1735 - 2.1905	16.80425 - 16.80475	960 - 1240	7.25 - 7.75
4.125 - 4.128	25.5 - 25.67	1300 - 1427	8.025 - 8.5
4.17725 - 4.17775	37.5 - 38.25	1435 - 1626.5	9.0 - 9.2
4.20725 - 4.20775	73 - 74.6	1645.5 - 1646.5	9.3 - 9.5
6.215 - 6.218	74.8 - 75.2	1660 - 1710	10.6 - 12.7
6.26775 - 6.26825	108 - 121.94	1718.8 - 1722.2	13.25 - 13.4
6.31175 - 6.31225	123 - 138	2200 - 2300	14.47 - 14.5
8.291 - 8.294	149.9 - 150.05	2310 - 2390	15.35 - 16.2
8.362 - 8.366	156.52475 -	2483.5 - 2500	17.7 - 21.4
8.37625 - 8.38675	156.52525	2655 - 2900	22.01 - 23.12
8.41425 - 8.41475	156.7 - 156.9	3260 - 3267	23.6 - 24.0
12.29 - 12.293	162.0125 - 167.17	3332 - 3339	31.2 - 31.8
12.51975 - 12.52025	167.72 - 173.2	3345.8 - 3358	36.43 - 36.5
12.57675 - 12.57725	240 - 285	3600 - 4400	(²)
13.36 - 13.41	322 - 335.4		

¹ Until February 1, 1999, this restricted band shall be 0.490-0.510 MHz.

² Above 38.6

(b) Except as provided in paragraphs (d) and (e), the field strength of emissions appearing within these frequency bands shall not exceed the limits shown in Section 15.209. At frequencies equal to or less than 1000 MHz, compliance with the limits in Section 15.209 shall be demonstrated using measurement instrumentation employing a CISPR quasi-peak detector. Above 1000 MHz, compliance with the emission limits in Section 15.209 shall be demonstrated based on the average value of the measured emissions. The provisions in Section 15.35 apply to these measurements.

3.5 DESCRIPTION OF TEST MODES

The EUT (model: TREK-688) had been tested under operating condition.

Software used to control the EUT for staying in continuous transmitting mode was programmed.

After verification, all tests were carried out with the worst case test modes as shown below except radiated spurious emission below 1GHz and power line conducted emissions below 30MHz, which worst case was in normal link mode only.

IEEE 802.11b mode:

Channel Low (2412MHz), Channel Mid (2437MHz) and Channel High (2462MHz) with 1Mbps data rate were chosen for full testing.

IEEE 802.11g mode:

Channel Low (2412MHz), Channel Mid (2437MHz) and Channel High (2462MHz) with 6Mbps data rate were chosen for full testing.

IEEE 802.11n HT 20 MHz mode:

Channel Low (2412MHz), Channel Mid (2437MHz) and Channel High (2462MHz) with 6.5Mbps data rate were chosen for full testing.

IEEE 802.11n HT 40 MHz mode:

Channel Low (2422MHz), Channel Mid (2437MHz) and Channel High (2452MHz) with 13.5Mbps data rate were chosen for full testing.

4. INSTRUMENT CALIBRATION

4.1 MEASURING INSTRUMENT CALIBRATION

The measuring equipment, which was utilized in performing the tests documented herein, has been calibrated in accordance with the manufacturer's recommendations for utilizing calibration equipment, which is traceable to recognized national standards.

4.2 MEASUREMENT EQUIPMENT USED

Equipment Used for Emissions Measurement

Remark: Each piece of equipment is scheduled for calibration once a year.

Conducted Emissions Test Site				
Name of Equipment	Manufacturer	Model	Serial Number	Calibration Due
Spectrum Analyzer	Agilent	E4446A	US42510252	12/07/2016
Thermostatic/Humidity Chamber	TAICHY	MHG-150LF	930619	10/07/2016
AC Power Source	EXTECH	6205	1140845	N.C.R
DC Power Supply	ABM	8301HD	D011531	N.C.R
Power Meter	Anritsu	ML2495A	1012009	07/07/2016
Power Sensor	Anritsu	MA2411A	0917072	07/07/2016
Spectrum Analyzer	ROHDE&SCHWARZ	FSV40	101073	07/19/2016

Wugu 966 Chamber A				
Name of Equipment	Manufacturer	Model	Serial Number	Calibration Due
Spectrum Analyzer	Agilent	E4446A	US42510268	01/25/2016
EMI Test Receiver	R&S	ESCI	100064	06/03/2016
Bilog Antenna	Sunol Sciences	JB3	A030105	08/05/2016
Horn Antenna	EMCO	3117	00055165	01/26/2016
Horn Antenna	EMCO	3116	26370	12/25/2015
Turn Table	CCS	CC-T-1F	N/A	N.C.R
Antenna Tower	CCS	CC-A-1F	N/A	N.C.R
Controller	CCS	CC-C-1F	N/A	N.C.R
Pre-Amplifier	MITEQ	1652-3000	1490939	08/09/2016
Pre-Amplifier	EMC	EMC 012635	980151	06/04/2016
Pre-Amplifier	MITEQ	AMF-6F-260400-40-8P	985646	12/25/2015
Coaxial Cable	Huber+Suhner	102	29212/2	12/25/2015
Coaxial Cable	Huber+Suhner	102	29406/2	12/25/2015
Test S/W	EZ-EMC (CCS-3A1RE)			

4.3 MEASUREMENT UNCERTAINTY

PARAMETER	UNCERTAINTY
Powerline Conducted Emission	N/A
3M Semi Anechoic Chamber / <200M	+/- 4.0138
3M Semi Anechoic Chamber / 200M~1000M	+/- 3.9483
3M Semi Anechoic Chamber / 1G~8G	+/- 2.5975
3M Semi Anechoic Chamber / 8G~18G	+/- 2.6112
3M Semi Anechoic Chamber / 18G~26G	+/- 2.7389
3M Semi Anechoic Chamber / 26G~40G	+/- 2.9683

Remark: This uncertainty represents an expanded uncertainty expressed at approximately the 95% confidence level using a coverage factor of $k=2$.

5. FACILITIES AND ACCREDITATIONS

5.1 FACILITIES

All measurement facilities used to collect the measurement data are located at

- No.139, Wugong Rd., Wugu Dist., New Taipei City 24891, Taiwan (R.O.C.)
Tel: 886-2-2298-4086 / Fax: 886-2-2298-1470
- No.11, Wugong 6th Rd., Wugu Dist., New Taipei City 24891, Taiwan. (R.O.C.)
Tel: 886-2-2299-9720 / Fax: 886-2-2298-4045
- No.81-1, Lane 210, Bade 2nd Rd., Lujhu Township, Taoyuan County 33841, TAIWAN,
R.O.C.
Tel: 886-3-324-0332 / Fax: 886-3-324-5235

The sites are constructed in conformance with the requirements of ANSI C63.7, ANSI C63.10: 2013 and CISPR Publication 22.

5.2 EQUIPMENT



Radiated emissions are measured with one or more of the following types of linearly polarized antennas: tuned dipole, biconical, log periodic, bi-log, and/or ridged waveguide, horn. Spectrum analyzers with pre-selectors and quasi-peak detectors are used to perform radiated measurements.

Conducted emissions are measured with Line Impedance Stabilization Networks and EMI Test Receivers.

Calibrated wideband preamplifiers, coaxial cables, and coaxial attenuators are also used for making measurements.

All receiving equipment conforms to CISPR Publication 16-1, "Radio Interference Measuring Apparatus and Measurement Methods."

5.3 TABLE OF ACCREDITATIONS AND LISTINGS

Country	Agency	Scope of Accreditation	Logo
USA	FCC	3M Semi Anechoic Chamber (FCC MRA: TW1039) to perform FCC Part 15 measurements	
Taiwan	TAF	LP0002, RTTE01, FCC Method-47 CFR Part 15 Subpart C, D, E, RSS-210, RSS-310 IDA TS SRD, AS/NZS 4268, AS/NZS 4771, TS 12.1 & 12.2, ETSI EN 300 440-1, ETSI EN 300 440-2, ETSI EN 300 328, ETSI EN 300 220-1, ETSI EN 300 220-2, ETSI EN 301 893, ETSI EN 301 489-1/3/7/17 FCC OET Bulletin 65 + Supplement C, EN 50360, EN 50361, EN 50371, RSS 102, EN 50383, EN 50385, EN 50392, IEC 62209, CNS 14958-1, CNS 14959 FCC Method -47 CFR Part 15 Subpart B IEC / EN 61000-3-2, IEC / EN 61000-3-3, IEC / EN 61000-4-2/3/4/5/6/8/11	
Canada	Industry Canada	3M Semi Anechoic Chamber (IC 2324G-1 / IC 2324G-2) to perform	

** No part of this report may be used to claim or imply product endorsement by A2LA or any agency of the US Government.*

6. SETUP OF EQUIPMENT UNDER TEST

6.1 SETUP CONFIGURATION OF EUT

See test photographs attached in Appendix II for the actual connections between EUT and support equipment.

6.2 SUPPORT EQUIPMENT

No	Device Type	Brand	Model	Series No.	FCC ID	Data Cable	Power Cord
	N/A						

Remark:

1. *All the equipment/cables were placed in the worst-case configuration to maximize the emission during the test.*
2. *Grounding was established in accordance with the manufacturer's requirements and conditions for the intended use.*

7. FCC PART 15.247 REQUIREMENTS

7.1 6DB BANDWIDTH

LIMIT

According to §15.247(a)(2), systems using digital modulation techniques may operate in the 902 - 928 MHz, 2400 - 2483.5 MHz, and 5725 - 5850 MHz bands. The minimum 6dB bandwidth shall be at least 500 kHz.

Test Configuration

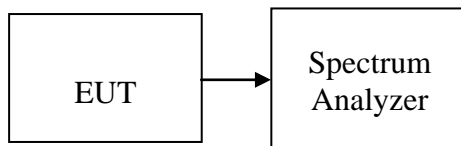

TEST PROCEDURE

The transmitter output is connected to the spectrum analyzer. Set the RBW=100kHz the emission bandwidth, VBW $\geq 3 \times$ RBW, Detector = Peak, Trace mode = max hold, Sweep = auto couple. Measure the maximum width of the emission that is constrained by the frequencies associated with the two amplitude points (upper and lower) that are attenuated by 6dB relative to the maximum level measured in the fundamental emission.

TEST RESULTS

No non-compliance noted

Test Data

Test mode: IEEE 802.11b mode

Frequency (MHz)	6dB Bandwidth (MHz)	Limit (kHz)	Result
2412	10.0961	>500	PASS
2437	10.0961		PASS
2462	10.0961		PASS

Test mode: IEEE 802.11g mode

Frequency (MHz)	6dB Bandwidth (MHz)	Limit (kHz)	Result
2412	16.3942	>500	PASS
2437	16.4423		PASS
2462	16.5384		PASS

Test mode: IEEE 802.11n HT 20 MHz mode

Frequency (MHz)	6dB Bandwidth (MHz)	Limit (kHz)	Result
2412	17.5480	>500	PASS
2437	17.7403		PASS
2462	17.7403		PASS

Test mode: IEEE 802.11n HT 40 MHz mode

Frequency (MHz)	6dB Bandwidth (MHz)	Limit (kHz)	Result
2422	36.5384	>500	PASS
2437	36.5384		PASS
2452	36.5384		PASS

IEEE 802.11b mode / 2412 MHz
6dB Bandwidth

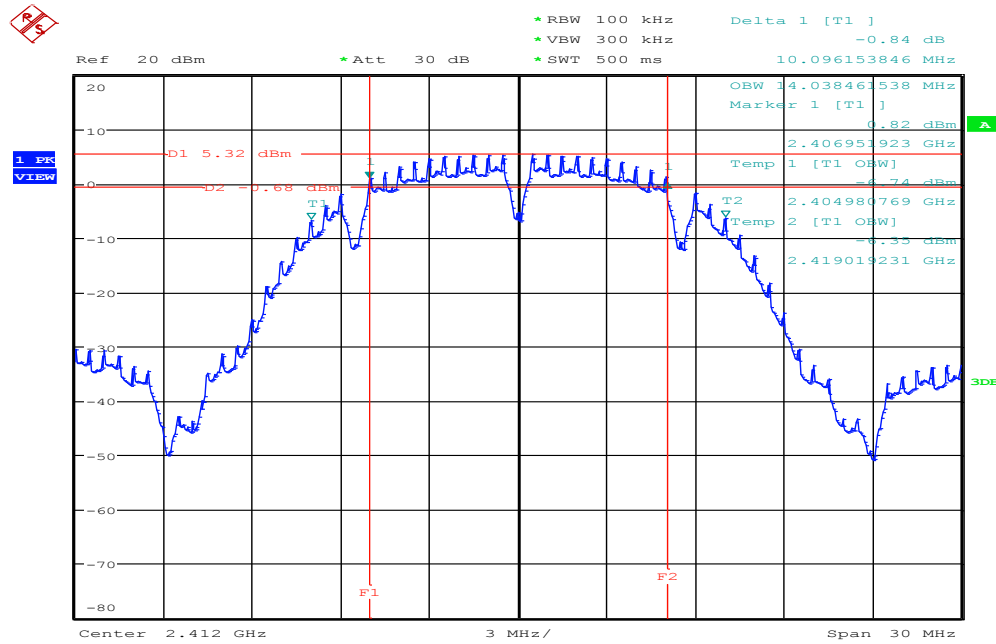

Date: 10.NOV.2015 23:48:43

IEEE 802.11b mode / 2437 MHz
6dB Bandwidth

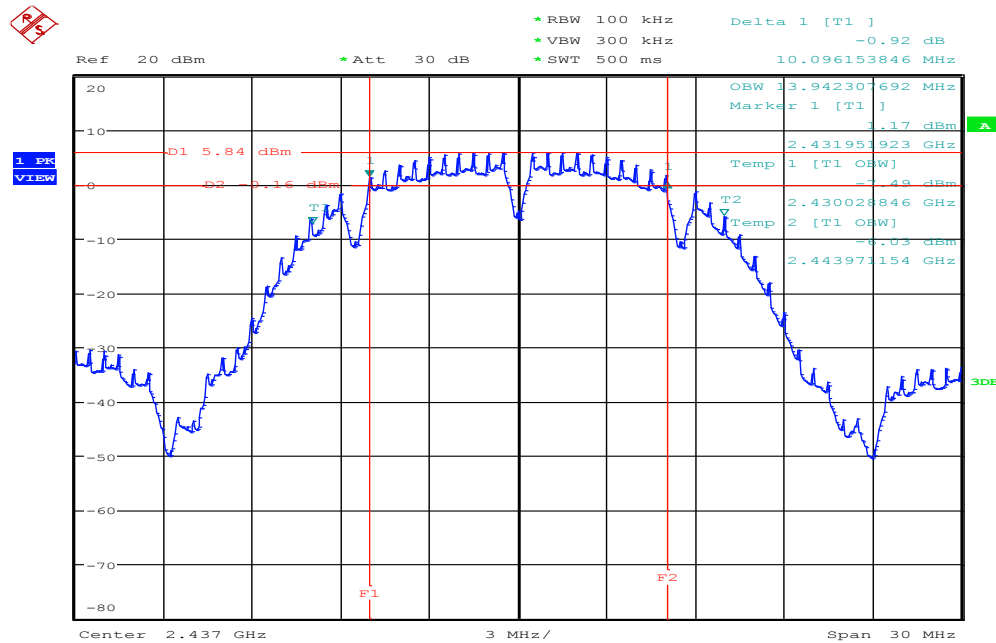

Date: 11.NOV.2015 00:02:24

IEEE 802.11b mode / 2462 MHz

6dB Bandwidth

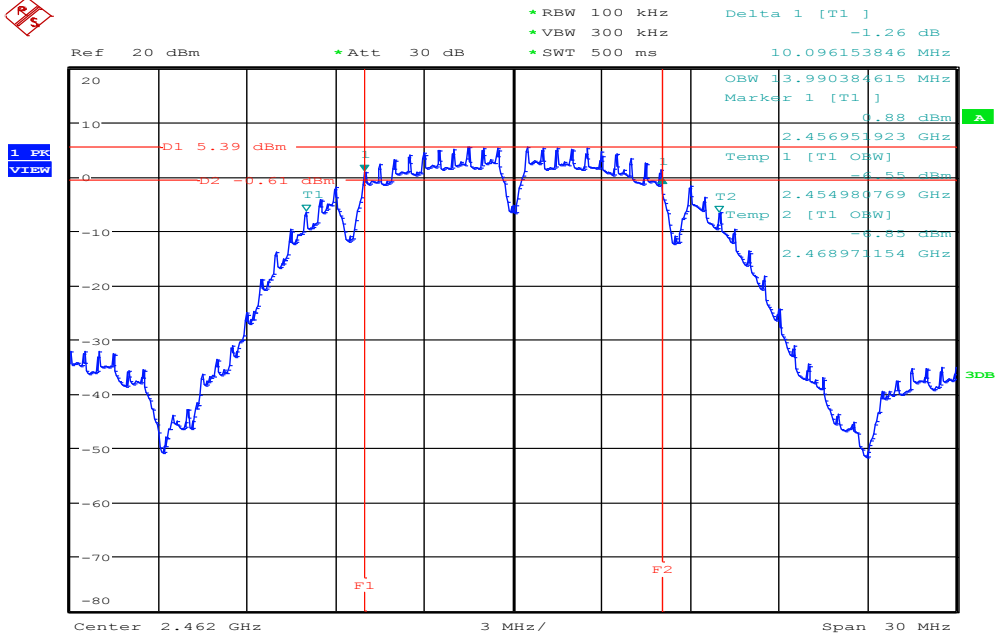

Date: 11.NOV.2015 00:07:39

IEEE 802.11g mode / 2412 MHz

6dB Bandwidth

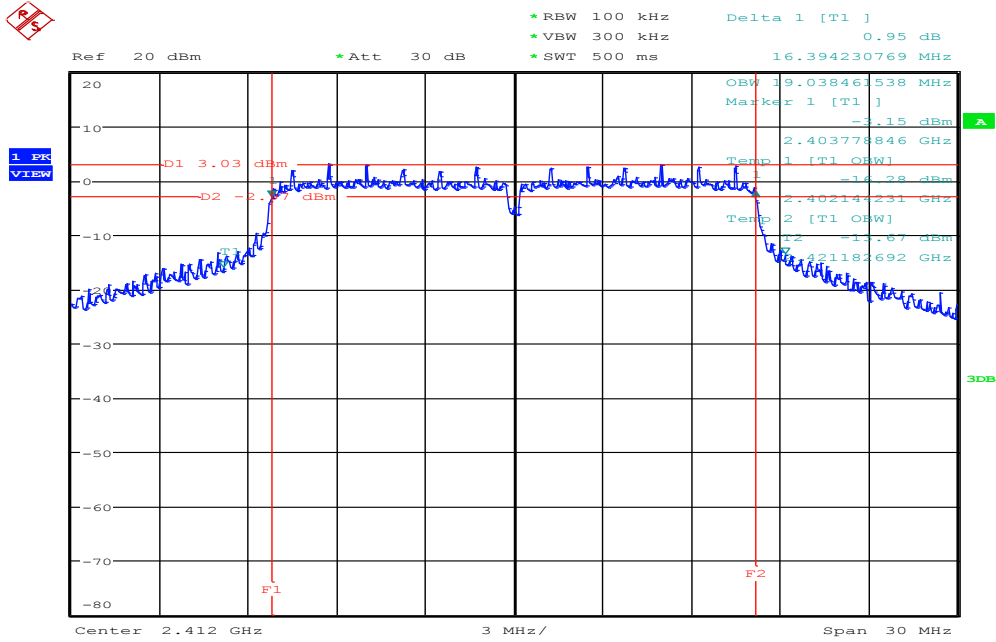

Date: 11.NOV.2015 00:15:37

IEEE 802.11g mode / 2437 MHz

6dB Bandwidth

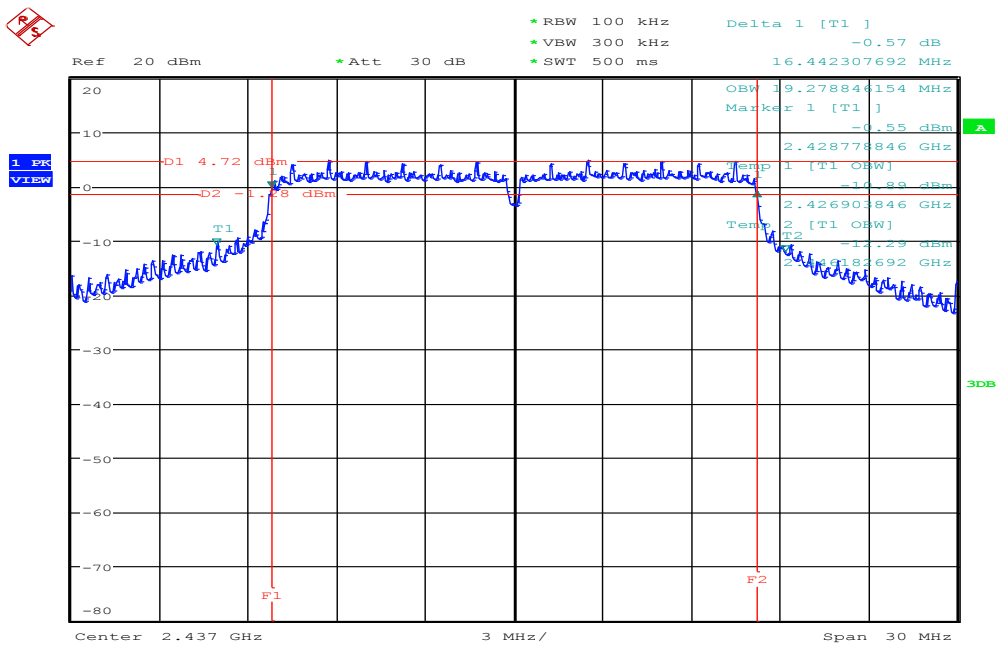

Date: 11.NOV.2015 00:25:40

IEEE 802.11g mode / 2462 MHz

6dB Bandwidth

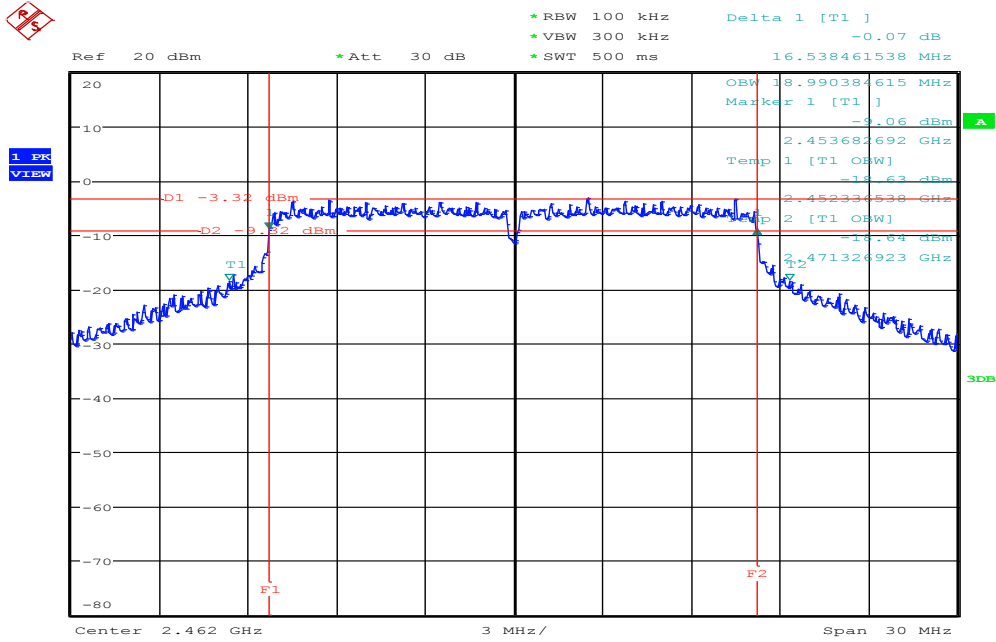

Date: 11.NOV.2015 00:30:33

IEEE 802.11n HT 20 MHz mode / 2412 MHz

6dB Bandwidth

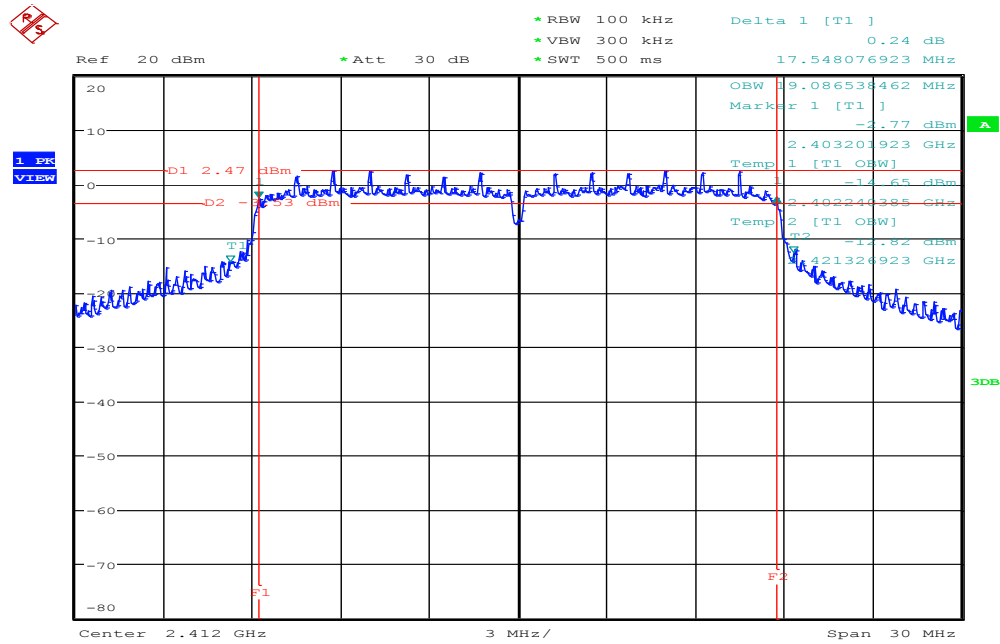

Date: 11.NOV.2015 00:37:13

IEEE 802.11n HT 20 MHz mode / 2437 MHz

6dB Bandwidth

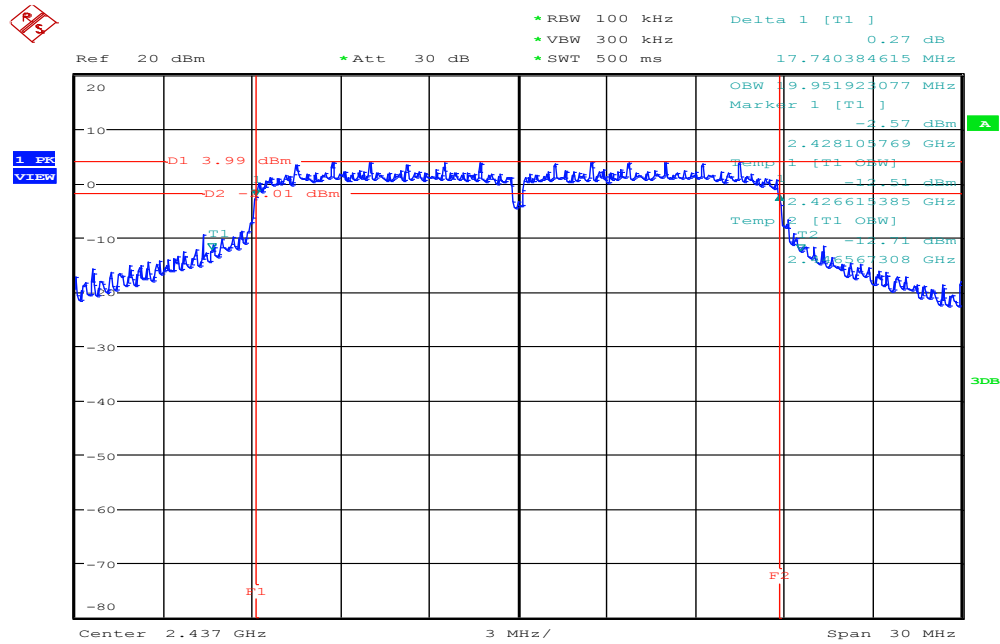

Date: 11.NOV.2015 00:43:42

IEEE 802.11n HT 20 MHz mode / 2462 MHz

6dB Bandwidth

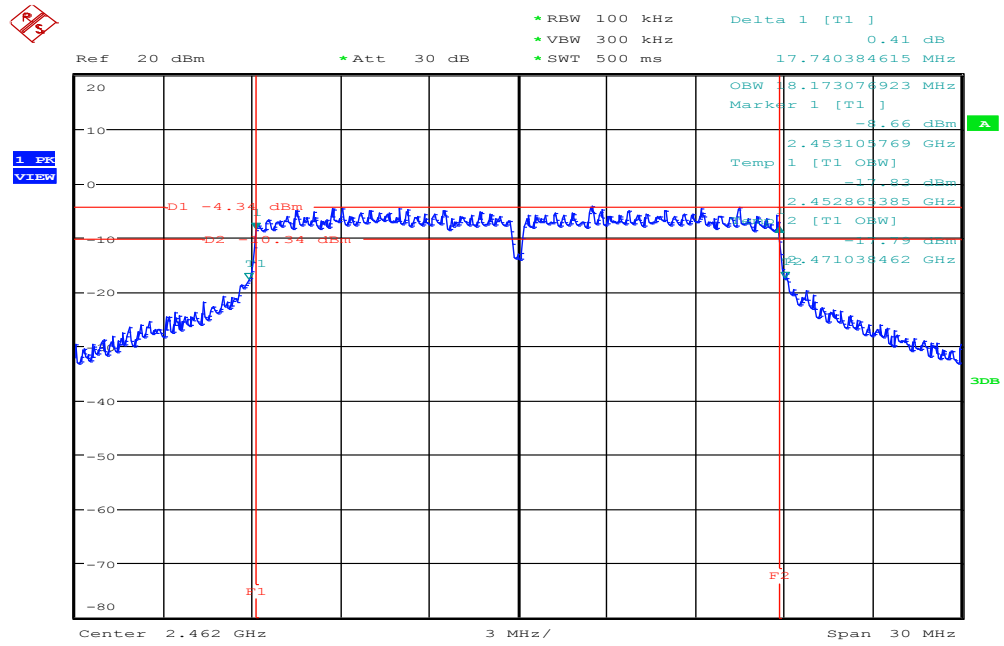

Date: 11.NOV.2015 00:47:12

IEEE 802.11n HT 40 MHz mode / 2422 MHz
6dB Bandwidth

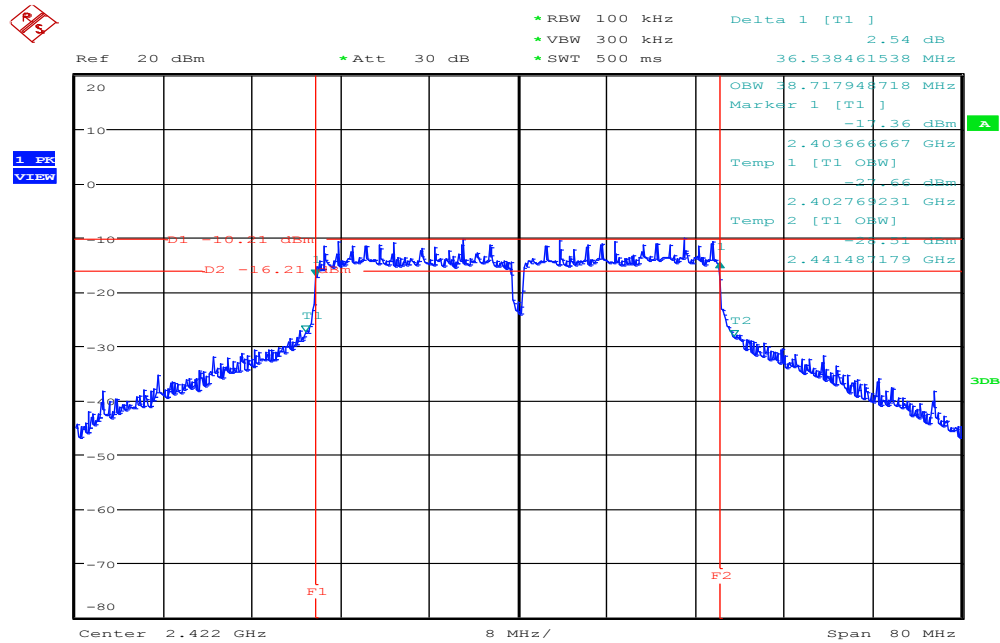

Date: 11.NOV.2015 01:32:26

IEEE 802.11n HT 40 MHz mode / 2437 MHz
6dB Bandwidth

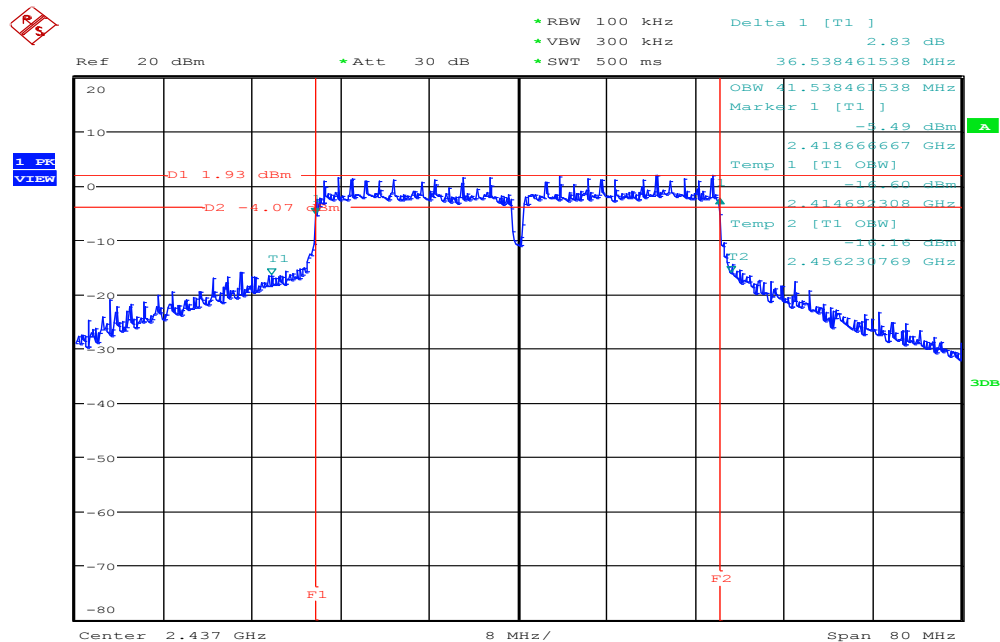

Date: 11.NOV.2015 01:06:43

IEEE 802.11n HT 40 MHz mode / 2452 MHz
6dB Bandwidth

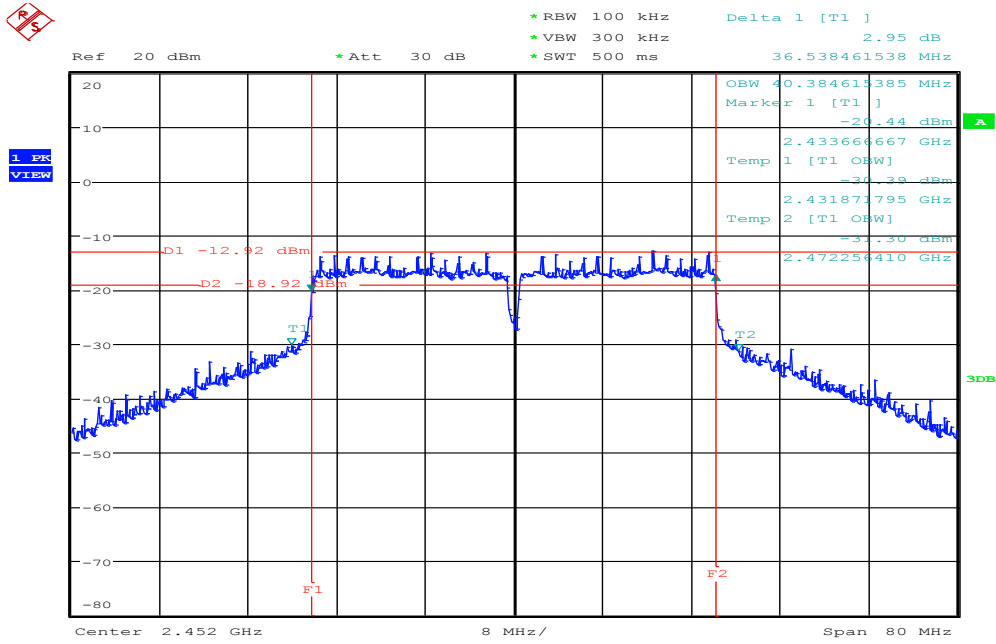

Date: 11.NOV.2015 01:10:47

7.2 PEAK POWER

LIMIT

The maximum peak output power of the intentional radiator shall not exceed the following:

1. According to §15.247(b)(3), for systems using digital modulation in the bands of 902-928 MHz, 2400-2483.5 MHz, and 5725-5850 MHz: 1 Watt.
2. According to §15.247(b)(4), the conducted output power limit specified in paragraph (b) of this section is based on the use of antennas with directional gains that do not exceed 6 dBi. Except as shown in paragraph (c) of this section, if transmitting antennas of directional gain greater than 6 dBi are used, the conducted output power from the intentional radiator shall be reduced below the stated values in paragraphs (b)(1), (b)(2), and (b)(3) of this section, as appropriate, by the amount in dB that the directional gain of the antenna exceeds 6 dBi.

Test Configuration

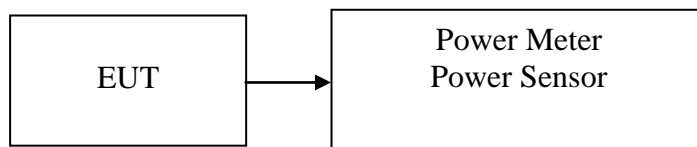

TEST PROCEDURE

The transmitter output is connected to the Power Meter. The Power Meter is set to the peak power detection.

TEST RESULTS

No non-compliance noted

Test Data

Test mode: IEEE 802.11b mode

Frequency (MHz)	Output Power (dBm)	Output Power (W)	Limit (W)	Result
2412	20.27	0.1064	1.00	PASS
2437	*22.92	0.1959		PASS
2462	19.92	0.0982		PASS

Test mode: IEEE 802.11g mode

Frequency (MHz)	Output Power (dBm)	Output Power (W)	Limit (W)	Result
2412	24.30	0.2692	1.00	PASS
2437	*24.68	0.2938		PASS
2462	23.14	0.2061		PASS

Test mode: IEEE 802.11n HT 20 MHz mode

Frequency (MHz)	Output Power (dBm)	Output Power (W)	Limit (W)	Result
2412	23.36	0.2168	1.00	PASS
2437	*24.42	0.2767		PASS
2462	22.74	0.1879		PASS

Test mode: IEEE 802.11n HT 40 MHz mode

Frequency (MHz)	Output Power (dBm)	Output Power (W)	Limit (W)	Result
2422	19.97	0.0993	1.00	PASS
2437	*22.02	0.1592		PASS
2452	20.89	0.1227		PASS

7.3 AVERAGE POWER

LIMIT

None; for reporting purposes only.

Test Configuration

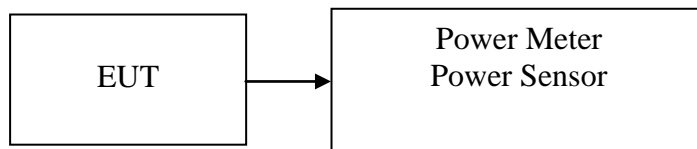

TEST PROCEDURE

The transmitter output is connected to the Power Meter. The Power Meter is set to the avg power detection.

TEST RESULTS

No non-compliance noted

Test Data

Test mode: IEEE 802.11b mode

Frequency (MHz)	Output Power (dBm)	Output Power (W)
2412	18.13	0.0650
2437	20.10	0.1023
2462	17.40	0.0550

Test mode: IEEE 802.11g mode

Frequency (MHz)	Output Power (dBm)	Output Power (W)
2412	15.99	0.0397
2437	19.46	0.0883
2462	13.61	0.0230

Test mode: IEEE 802.11n HT 20 MHz mode

Frequency (MHz)	Output Power (dBm)	Output Power (W)
2412	13.23	0.0210
2437	16.31	0.0428
2462	12.88	0.0194

Test mode: IEEE 802.11n HT 40 MHz mode

Frequency (MHz)	Output Power (dBm)	Output Power (W)
2422	10.14	0.0103
2437	12.85	0.0193
2452	11.22	0.0132

7.4 BAND EDGES MEASUREMENT

LIMIT

According to §15.247(d), in any 100 kHz bandwidth outside the frequency bands in which the spread spectrum intentional radiator is operating, the radio frequency power that is produced by the intentional radiator shall be at least 20 dB below that in the 100 kHz bandwidth within the band that contains the highest level of the desired power, based on either an RF conducted or a radiated measurement, provided the transmitter demonstrates compliance with the peak conducted power limits. In addition, radiated emissions which fall in the restricted bands, as defined in §15.205(a), must also comply with the radiated emission limits specified in 15.209(a) (see Section 15.205(c)).

Test Configuration

For Radiated Emission above 1GHz

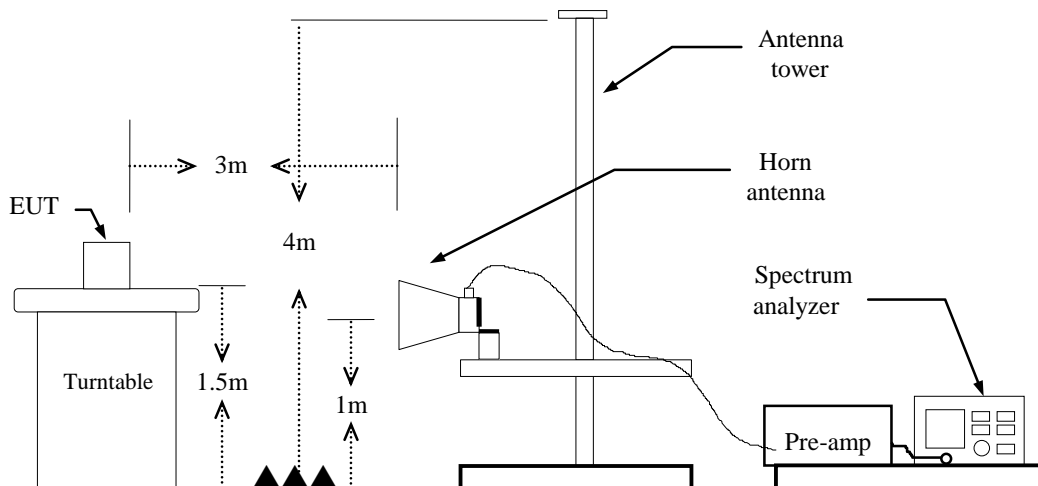

For Conducted

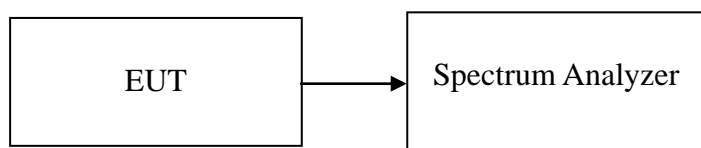

TEST PROCEDURE

For Radiated

1. The EUT is placed on a turntable, which is 1.5m above the ground plane.
2. The turntable shall be rotated for 360 degrees to determine the position of maximum emission level.
3. EUT is set 3m away from the receiving antenna, which is varied from 1m to 4m to find out the highest emission.
4. Set the spectrum analyzer in the following setting in order to capture the lower and upper band-edges of the emission:
 - (a) PEAK: RBW=1MHz / VBW=3MHz / Sweep=AUTO
 - (b) AVERAGE: RBW=1MHz,
if duty cycle $\geq 98\%$, VBW=10Hz.
if duty cycle $< 98\%$ VBW=1/T.
IEEE 802.11b mode: $\geq 98\%$, VBW=10Hz
IEEE 802.11g mode: $\geq 98\%$, VBW=10Hz
IEEE 802.11n HT 20 MHz mode: $\geq 98\%$, VBW=10Hz
IEEE 802.11n HT 40 MHz mode: $\geq 98\%$, VBW=10Hz
5. Repeat the procedures until all the PEAK and AVERAGE versus POLARIZATION are measured.
6. Result = Spectrum Reading + cable loss(spectrum to Amp) - Amp Gain + Cable loss(Amp to receive Ant)+ Receive Ant

For Conducted

Conducted RF measurements of the transmitter output were made to confirm that the EUT antenna port conducted emissions meet the specified limit and to identify any spurious signals that require further investigation or measurements on the radiated emissions site.

The transmitter output is connected to the spectrum analyzer. The resolution bandwidth is set to 100 kHz. The video bandwidth is set to 300 kHz.

TEST RESULTS

Refer to attach spectrum analyzer data chart.

Band Edges (IEEE 802.11b mode / 2412 MHz)

Polarity: Vertical

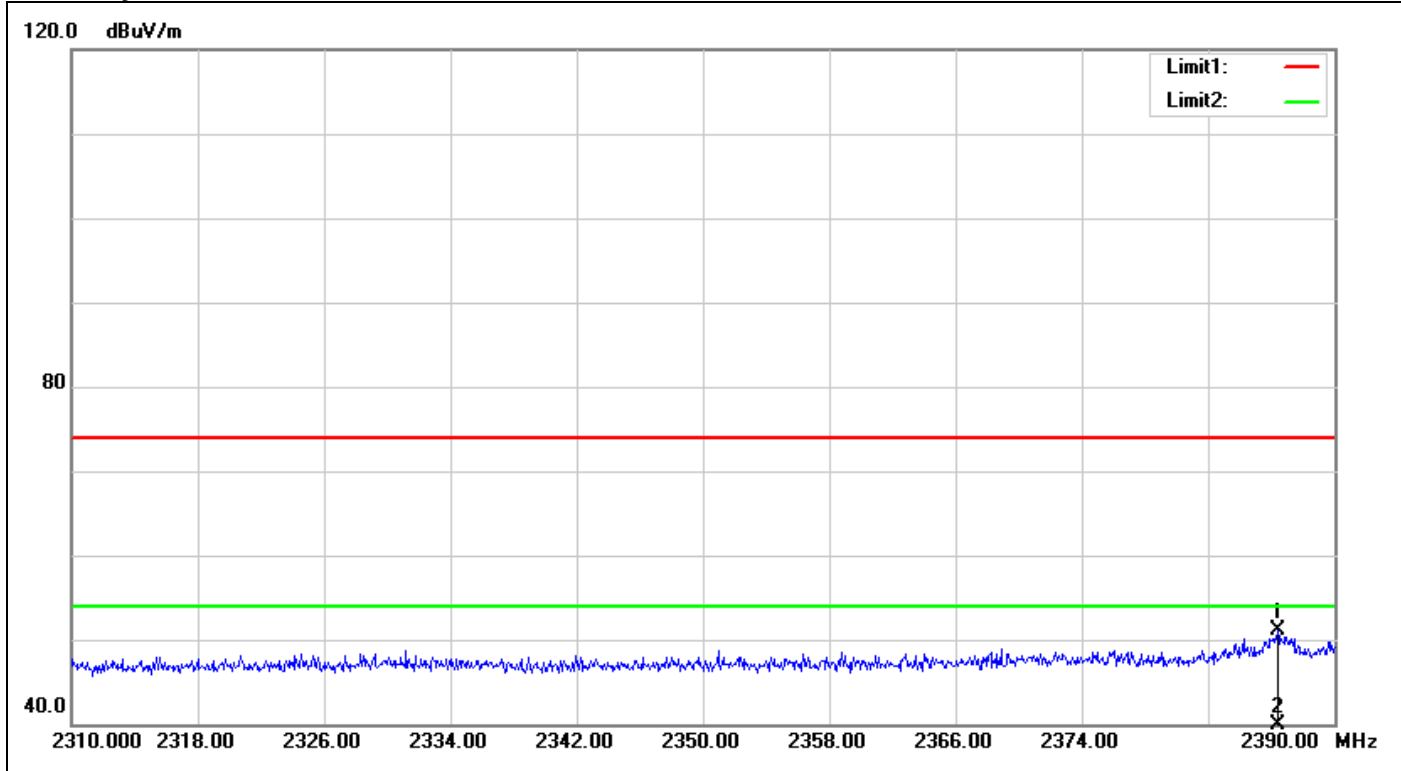

No.	Frequency (MHz)	Reading (dBuV)	Correct Factor(dB/m)	Result (dBuV/m)	Limit (dBuV/m)	Margin (dB)	Height (cm)	Degree (°)	Remark
1	2386.400	53.62	-2.52	51.10	74.00	-22.90	150	122	peak
2	2386.400	41.94	-2.52	39.42	54.00	-14.58	150	122	AVG

Polarity: Horizontal

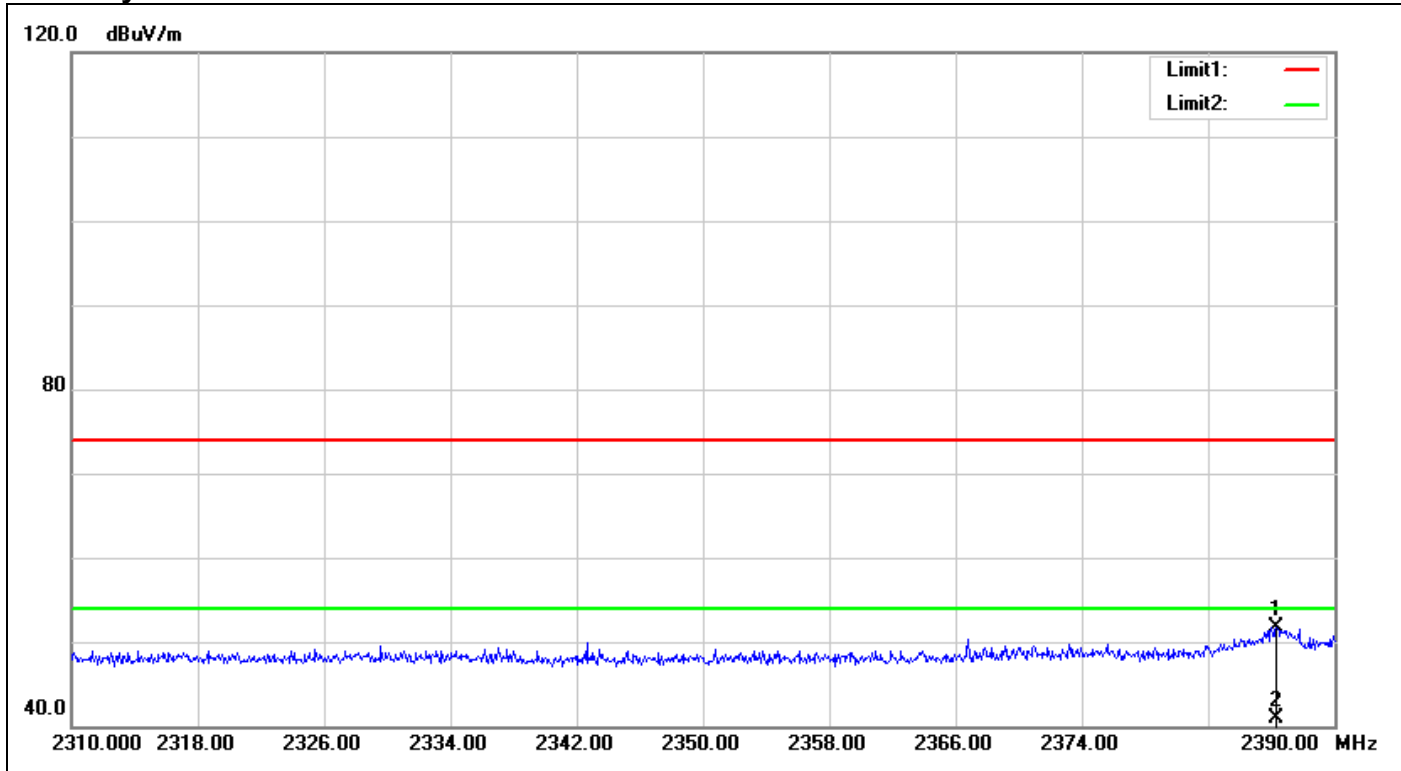

No.	Frequency (MHz)	Reading (dBuV)	Correct Factor(dB/m)	Result (dBuV/m)	Limit (dBuV/m)	Margin (dB)	Height (cm)	Degree (°)	Remark
1	2386.320	54.18	-2.52	51.66	74.00	-22.34	150	49	peak
2	2386.320	43.45	-2.52	40.93	54.00	-13.07	150	49	AVG

Band Edges (IEEE 802.11b mode / 2462 MHz)

Polarity: Vertical

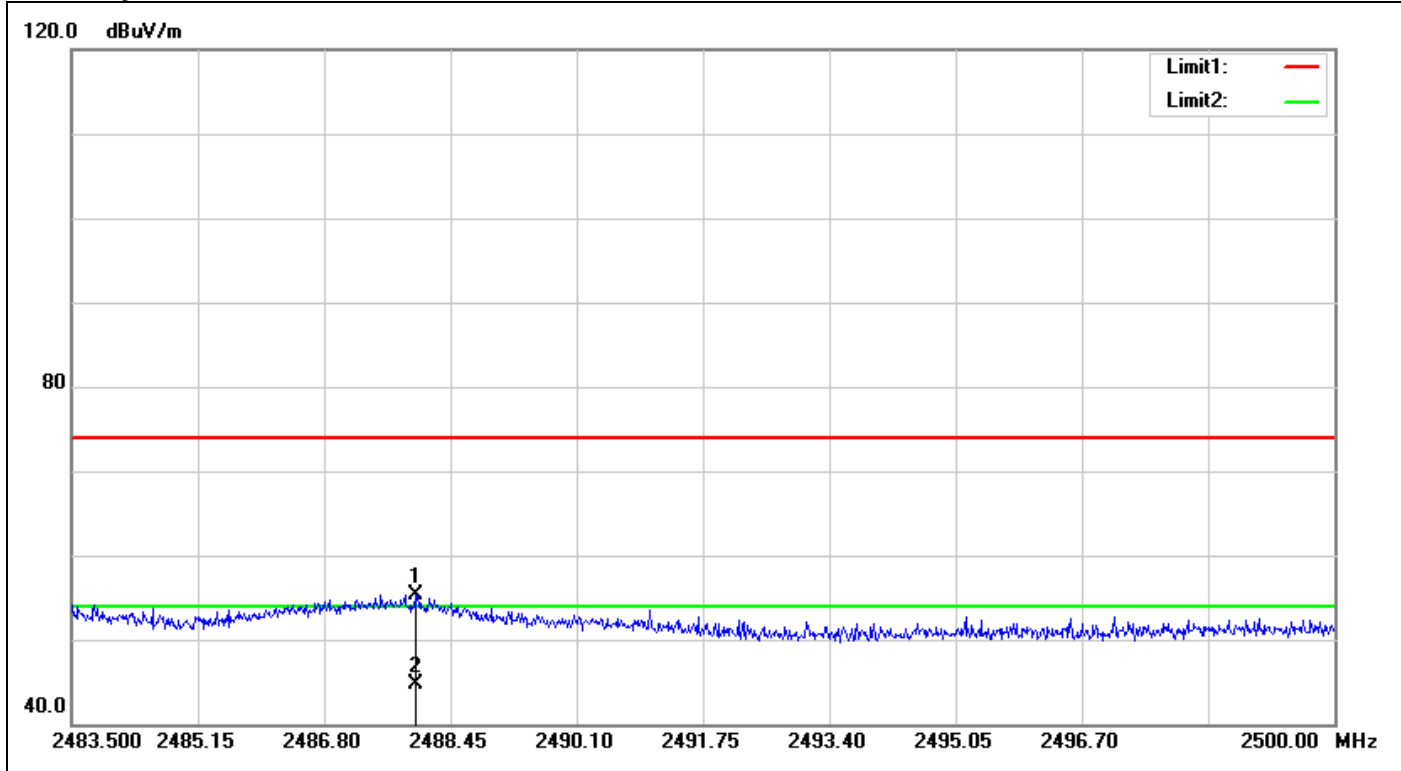

No.	Frequency (MHz)	Reading (dBuV)	Correct Factor(dB/m)	Result (dBuV/m)	Limit (dBuV/m)	Margin (dB)	Height (cm)	Degree (°)	Remark
1	2487.988	57.35	-1.95	55.40	74.00	-18.60	150	0	peak
2	2487.988	46.67	-1.95	44.72	54.00	-9.28	150	0	AVG

Polarity: Horizontal

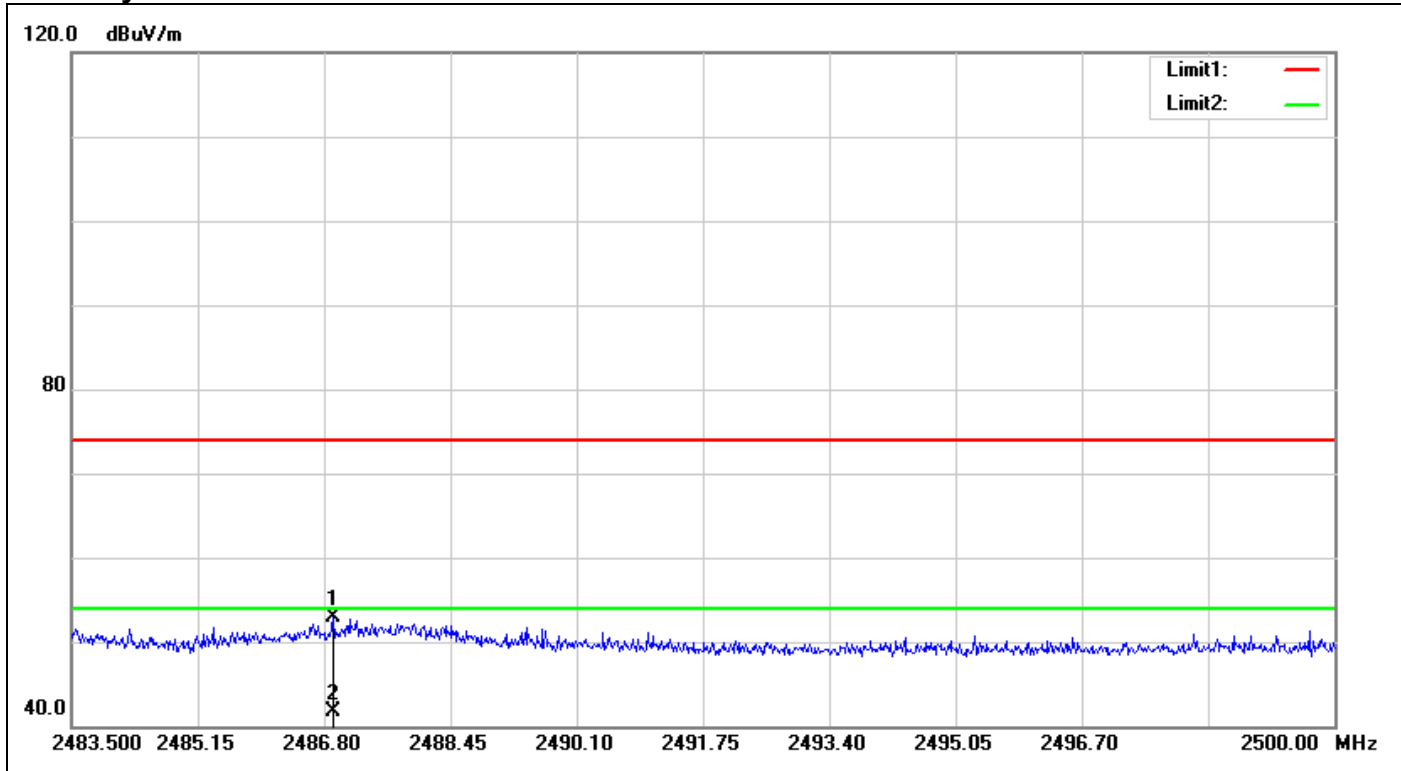

No.	Frequency (MHz)	Reading (dBuV)	Correct Factor(dB/m)	Result (dBuV/m)	Limit (dBuV/m)	Margin (dB)	Height (cm)	Degree (°)	Remark
1	2486.916	54.85	-1.96	52.89	74.00	-21.11	150	130	peak
2	2486.916	43.68	-1.96	41.72	54.00	-12.28	150	130	AVG

Band Edges (IEEE 802.11g mode / 2412 MHz)

Polarity: Vertical

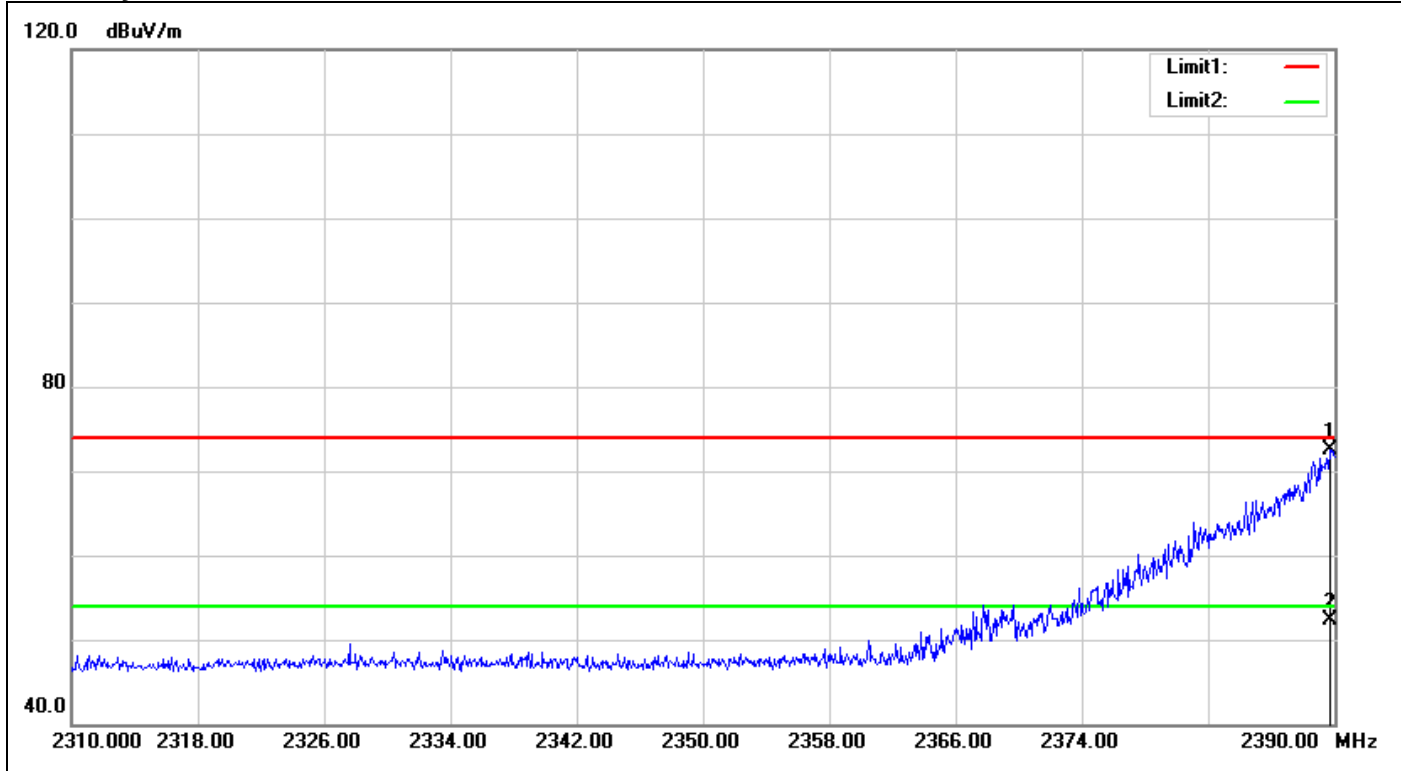

No.	Frequency (MHz)	Reading (dBuV)	Correct Factor(dB/m)	Result (dBuV/m)	Limit (dBuV/m)	Margin (dB)	Height (cm)	Degree (°)	Remark
1	2389.680	75.05	-2.49	72.56	74.00	-1.44	100	22	peak
2	2389.680	54.82	-2.49	52.33	54.00	-1.67	100	22	AVG

Polarity: Horizontal

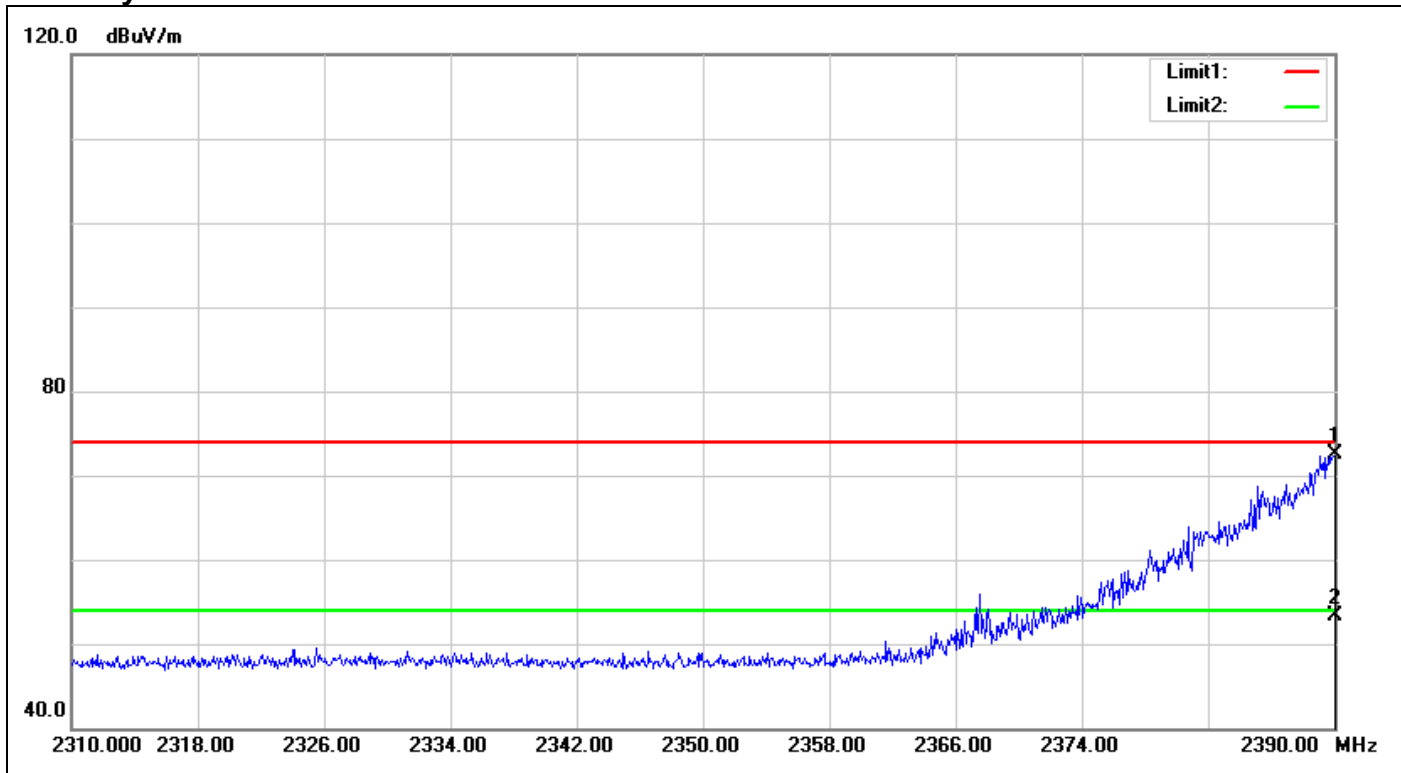

No.	Frequency (MHz)	Reading (dBuV)	Correct Factor(dB/m)	Result (dBuV/m)	Limit (dBuV/m)	Margin (dB)	Height (cm)	Degree (°)	Remark
1	2390.000	74.97	-2.49	72.48	74.00	-1.52	100	160	peak
2	2390.000	55.84	-2.49	53.35	54.00	-0.65	100	160	AVG

Band Edges (IEEE 802.11g mode / 2462 MHz)

Polarity: Vertical

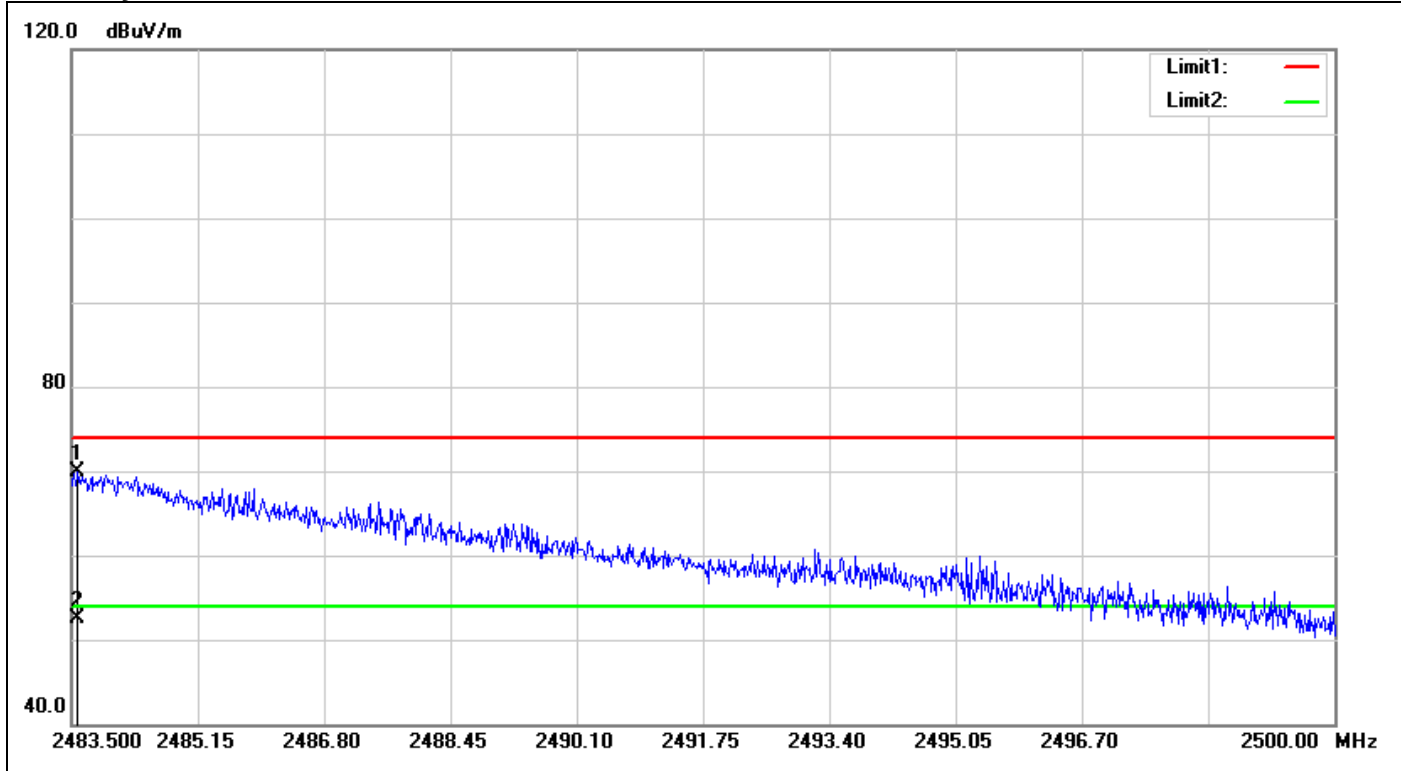

No.	Frequency (MHz)	Reading (dBuV)	Correct Factor(dB/m)	Result (dBuV/m)	Limit (dBuV/m)	Margin (dB)	Height (cm)	Degree (°)	Remark
1	2483.582	71.86	-1.99	69.87	74.00	-4.13	150	145	peak
2	2483.582	54.52	-1.99	52.53	54.00	-1.47	150	145	AVG

Polarity: Horizontal

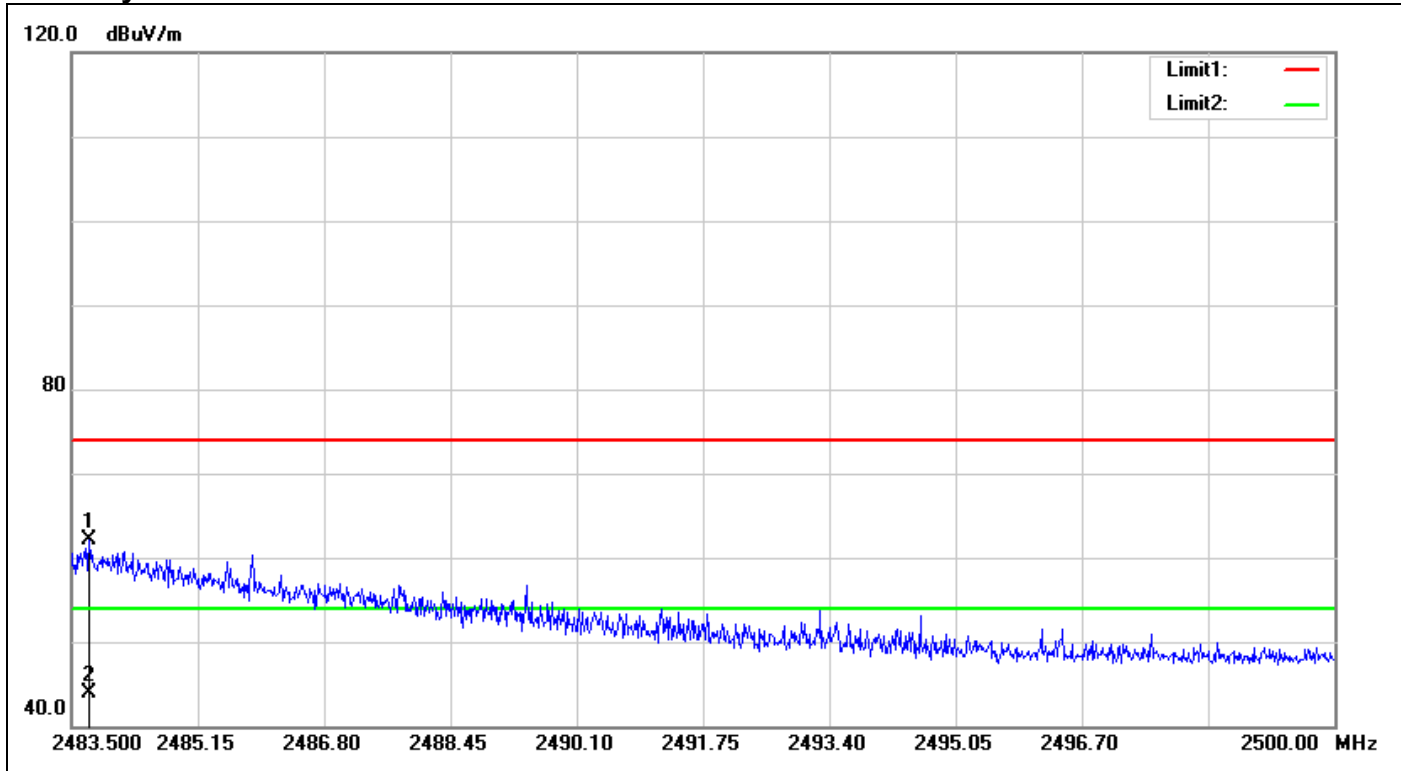

No.	Frequency (MHz)	Reading (dBuV)	Correct Factor(dB/m)	Result (dBuV/m)	Limit (dBuV/m)	Margin (dB)	Height (cm)	Degree (°)	Remark
1	2483.731	64.02	-1.99	62.03	74.00	-11.97	150	226	peak
2	2483.731	45.93	-1.99	43.94	54.00	-10.06	150	226	AVG

Band Edges (IEEE 802.11n HT 20 MHz mode / 2412 MHz)

Polarity: Vertical

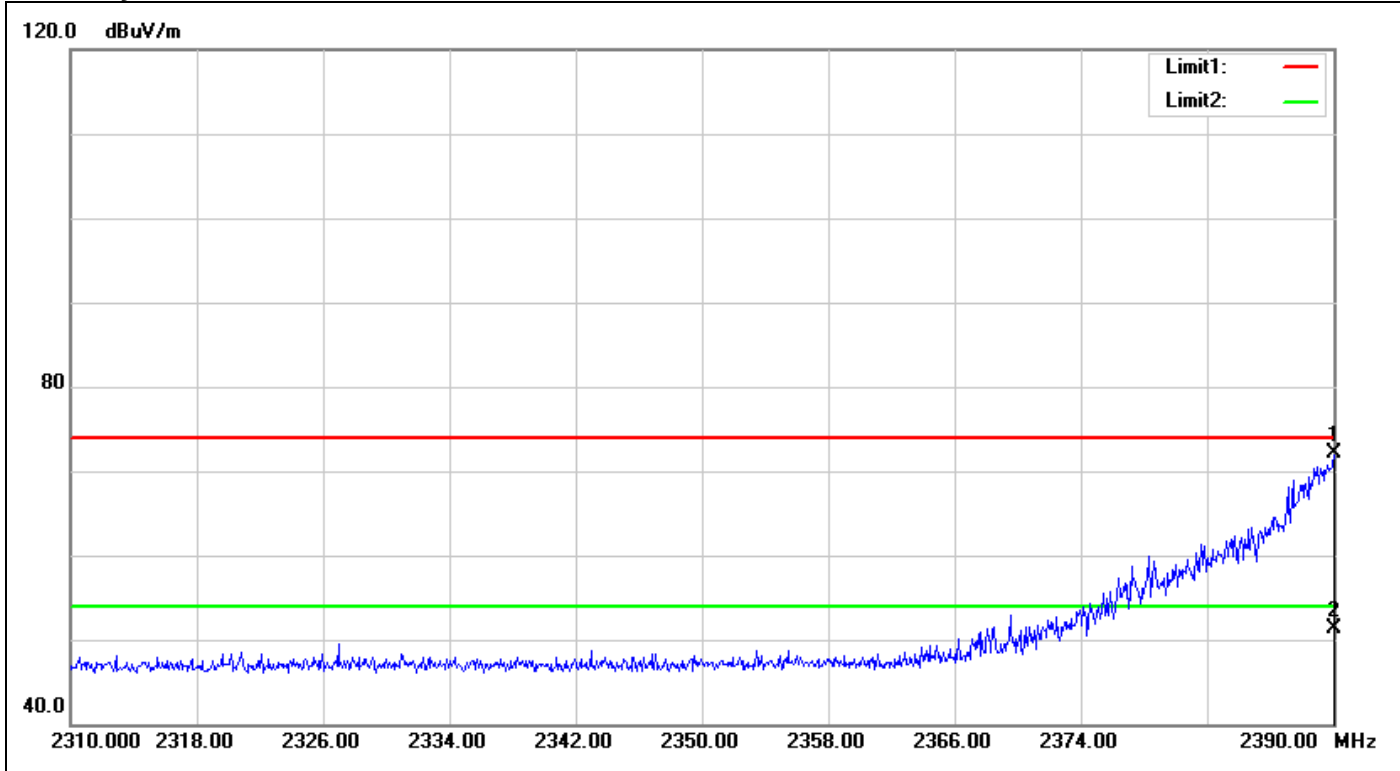

No.	Frequency (MHz)	Reading (dBuV)	Correct Factor(dB/m)	Result (dBuV/m)	Limit (dBuV/m)	Margin (dB)	Height (cm)	Degree (°)	Remark
1	2390.000	74.63	-2.49	72.14	74.00	-1.86	150	82	peak
2	2390.000	53.85	-2.49	51.36	54.00	-2.64	150	82	AVG

Polarity: Horizontal

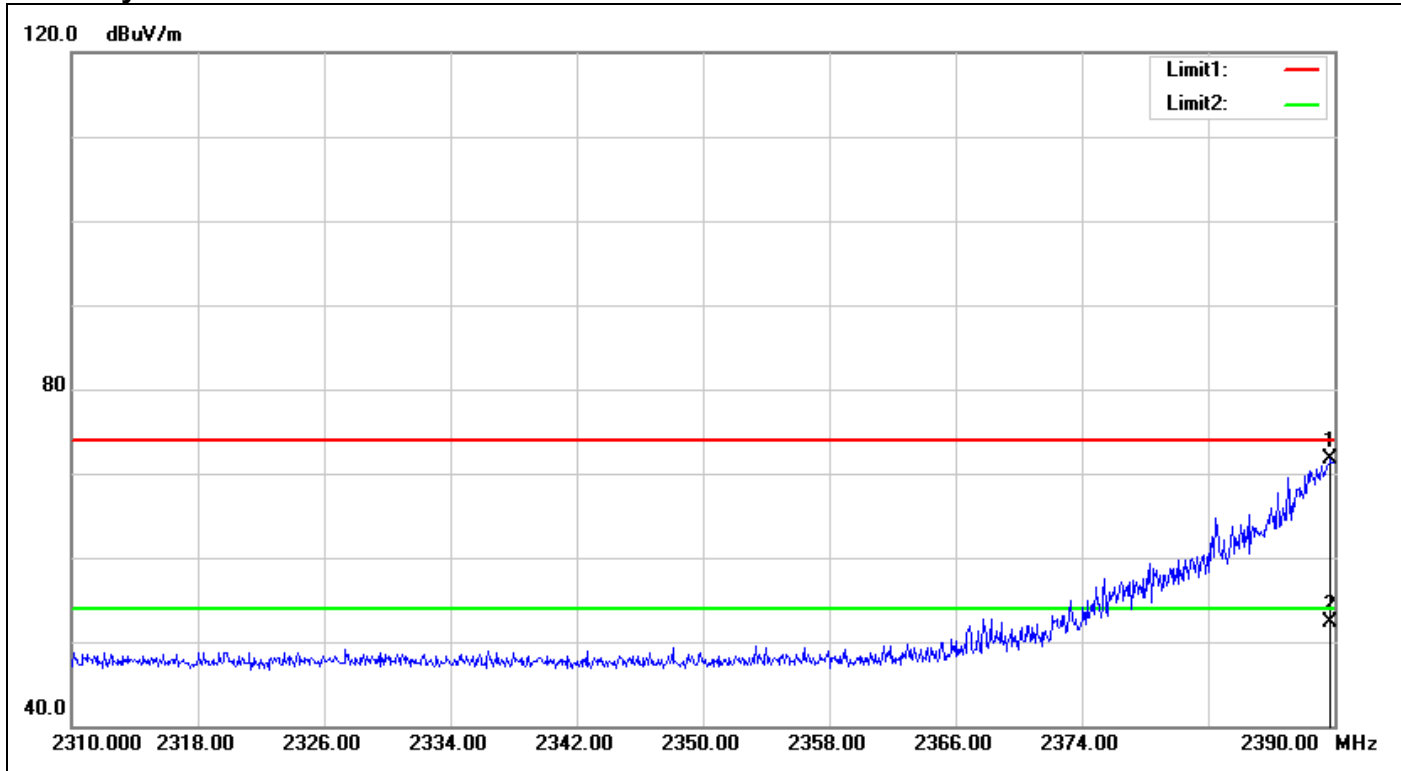

No.	Frequency (MHz)	Reading (dBuV)	Correct Factor(dB/m)	Result (dBuV/m)	Limit (dBuV/m)	Margin (dB)	Height (cm)	Degree (°)	Remark
1	2389.760	74.16	-2.49	71.67	74.00	-2.33	150	303	peak
2	2389.760	54.86	-2.49	52.37	54.00	-1.63	150	303	AVG

Band Edges (IEEE 802.11n HT 20 MHz mode / 2462 MHz)

Polarity: Vertical

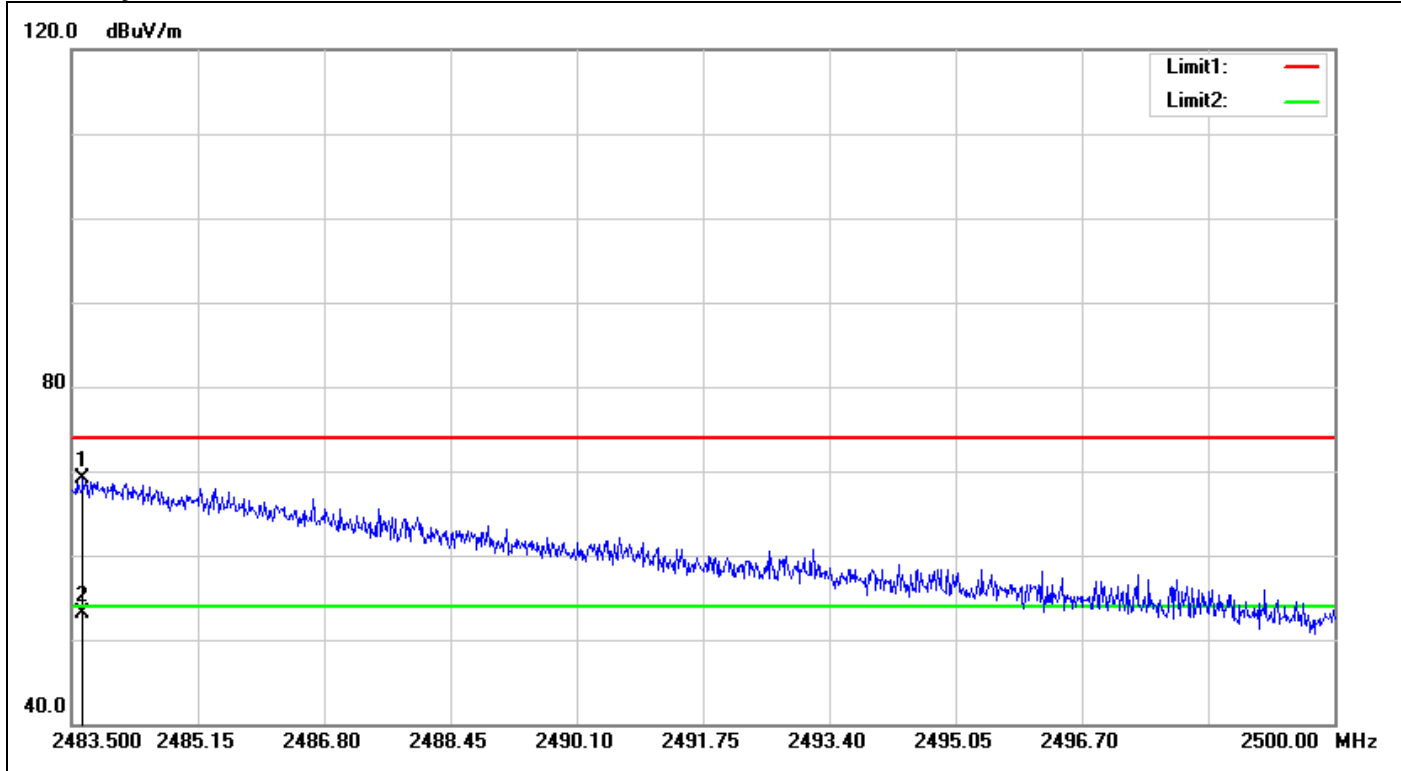

No.	Frequency (MHz)	Reading (dBuV)	Correct Factor(dB/m)	Result (dBuV/m)	Limit (dBuV/m)	Margin (dB)	Height (cm)	Degree (°)	Remark
1	2483.648	71.06	-1.99	69.07	74.00	-4.93	150	75	peak
2	2483.648	55.17	-1.99	53.18	54.00	-0.82	150	75	AVG

Polarity: Horizontal

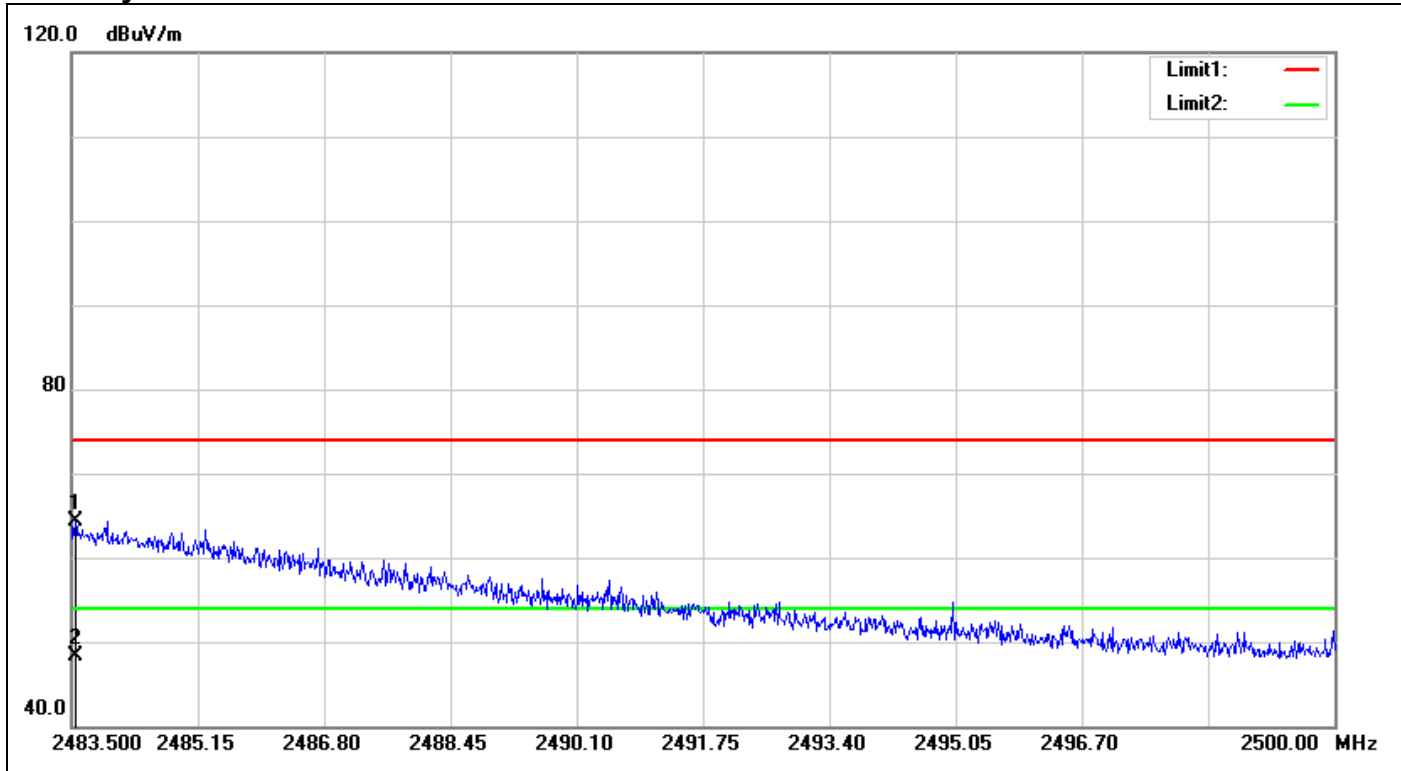

No.	Frequency (MHz)	Reading (dBuV)	Correct Factor(dB/m)	Result (dBuV/m)	Limit (dBuV/m)	Margin (dB)	Height (cm)	Degree (°)	Remark
1	2483.550	66.32	-1.99	64.33	74.00	-9.67	150	5	peak
2	2483.550	50.23	-1.99	48.24	54.00	-5.76	150	5	AVG

Band Edges (IEEE 802.11n HT 40 MHz mode / 2422 MHz)

Polarity: Vertical

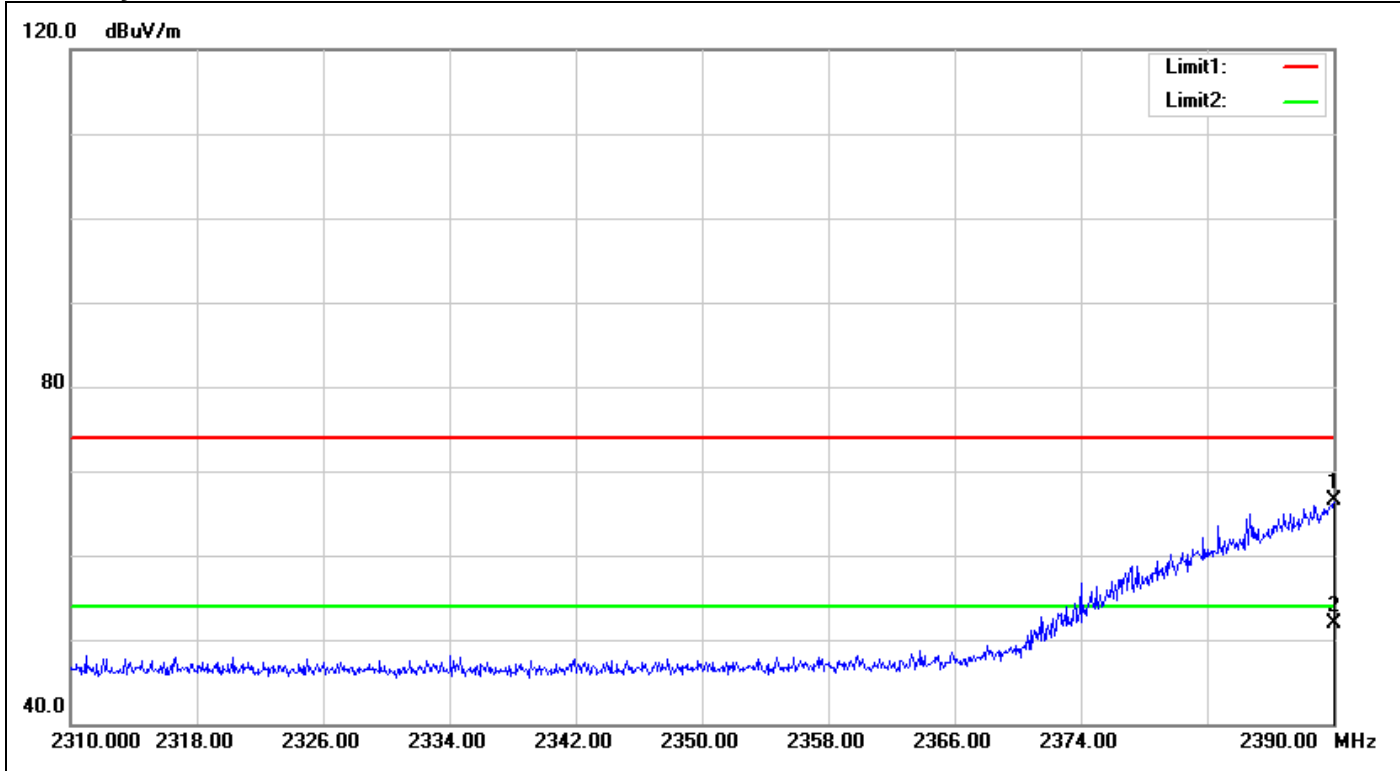

No.	Frequency (MHz)	Reading (dBuV)	Correct Factor(dB/m)	Result (dBuV/m)	Limit (dBuV/m)	Margin (dB)	Height (cm)	Degree (°)	Remark
1	2390.000	68.90	-2.49	66.41	74.00	-7.59	150	336	peak
2	2390.000	54.41	-2.49	51.92	54.00	-2.08	150	336	AVG

Polarity: Horizontal

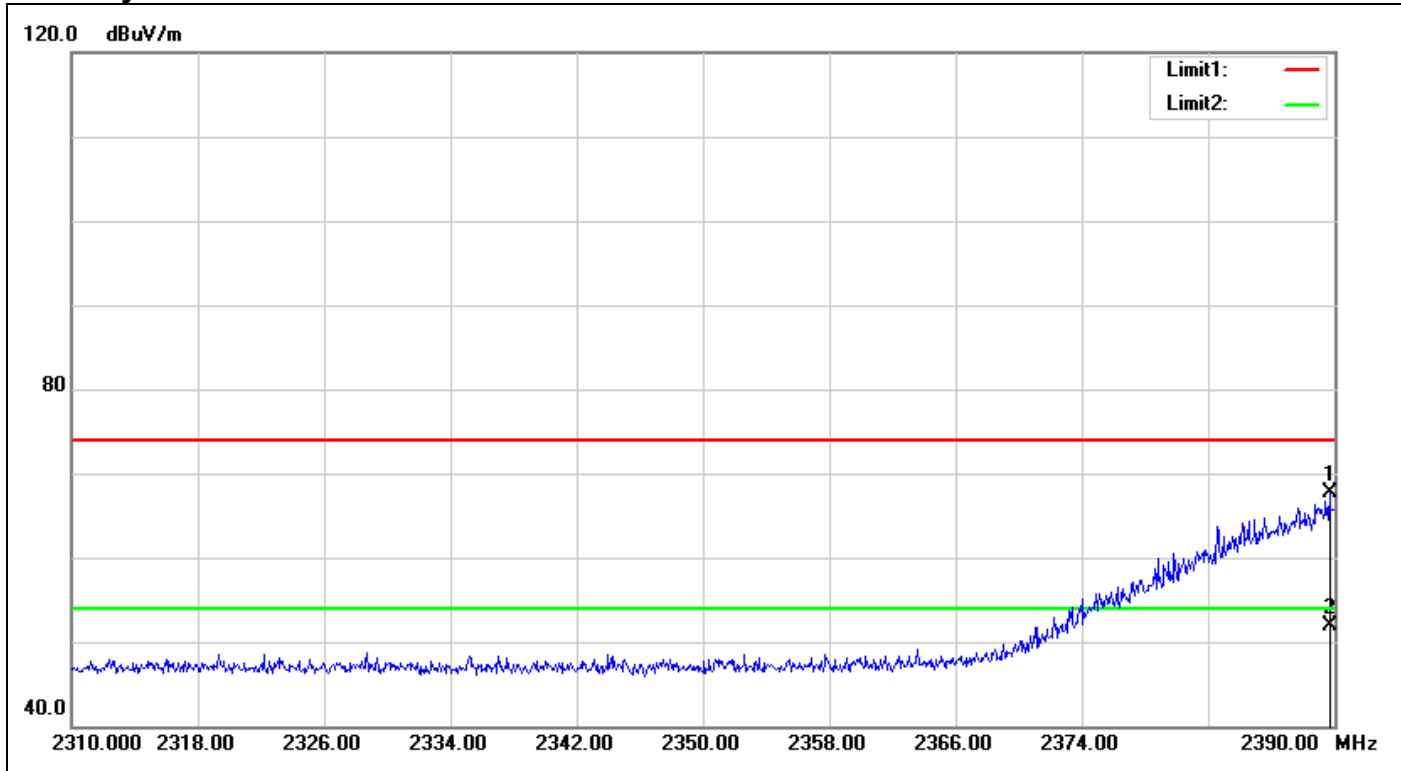

No.	Frequency (MHz)	Reading (dBuV)	Correct Factor(dB/m)	Result (dBuV/m)	Limit (dBuV/m)	Margin (dB)	Height (cm)	Degree (°)	Remark
1	2389.680	70.14	-2.49	67.65	74.00	-6.35	150	256	peak
2	2389.680	54.36	-2.49	51.87	54.00	-2.13	150	256	AVG

Band Edges (IEEE 802.11n HT 40 MHz mode / 2452 MHz)

Polarity: Vertical

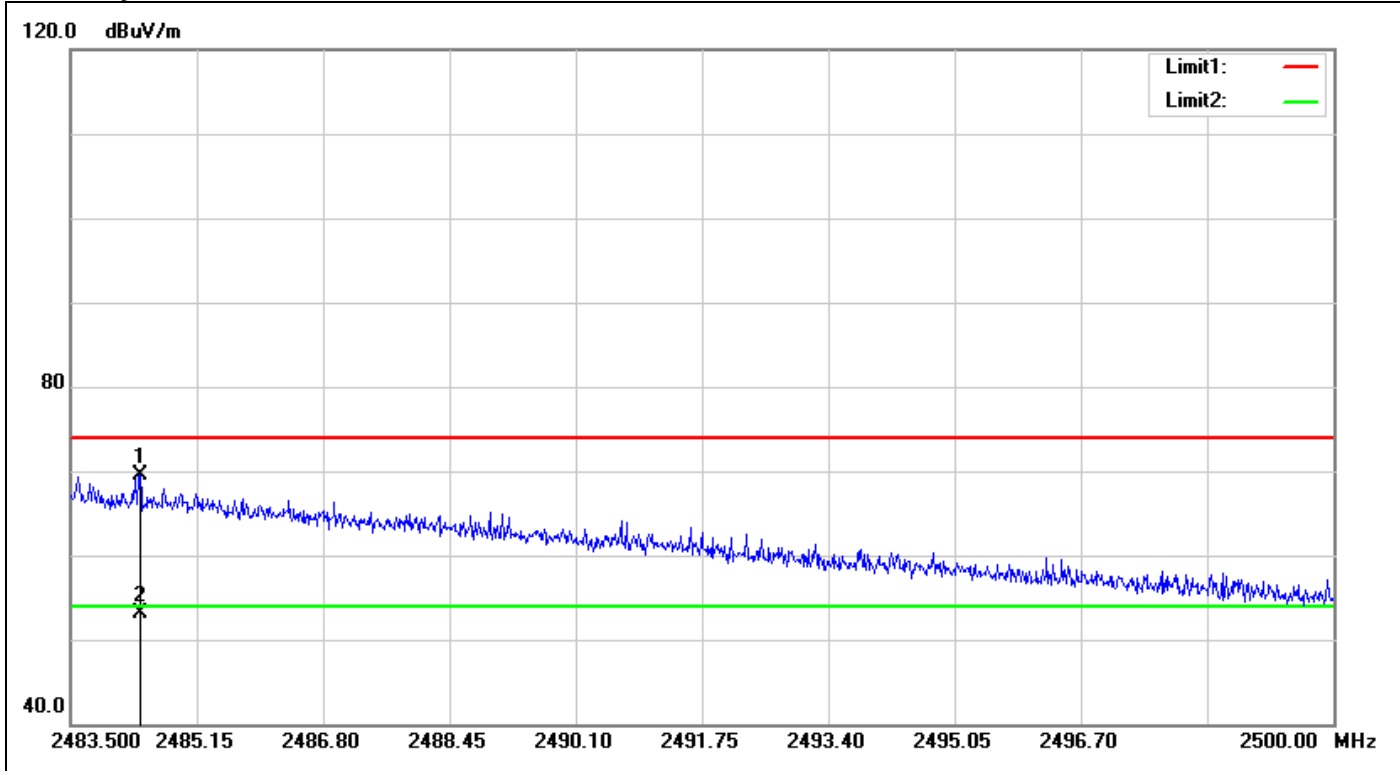

No.	Frequency (MHz)	Reading (dBuV)	Correct Factor(dB/m)	Result (dBuV/m)	Limit (dBuV/m)	Margin (dB)	Height (cm)	Degree (°)	Remark
1	2484.407	71.53	-1.99	69.54	74.00	-4.46	150	318	peak
2	2484.407	55.02	-1.99	53.03	54.00	-0.97	150	318	AVG

Polarity: Horizontal

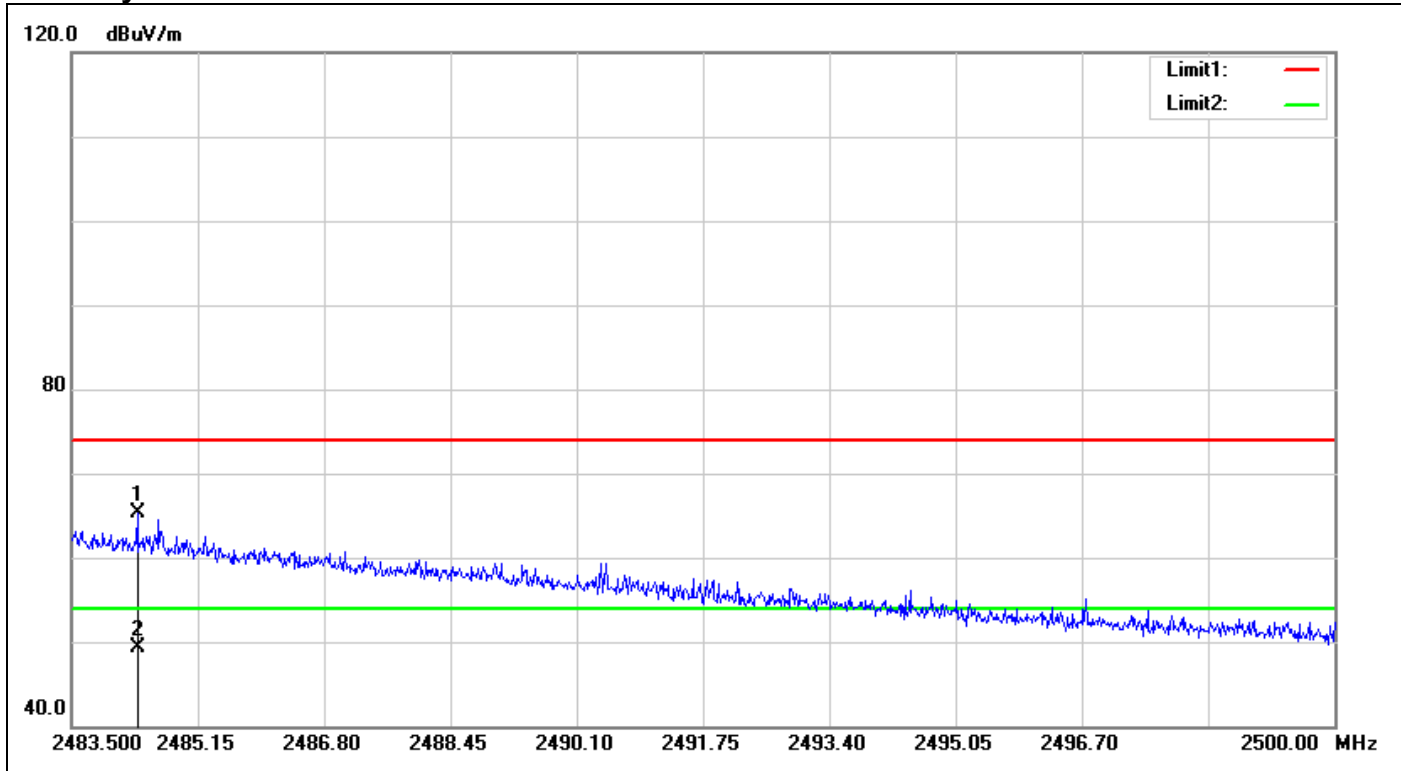

No.	Frequency (MHz)	Reading (dBuV)	Correct Factor(dB/m)	Result (dBuV/m)	Limit (dBuV/m)	Margin (dB)	Height (cm)	Degree (°)	Remark
1	2484.358	67.21	-1.99	65.22	74.00	-8.78	150	248	peak
2	2484.358	51.20	-1.99	49.21	54.00	-4.79	150	248	AVG

Test Plot

Conducted Band Edges (IEEE 802.11b mode / 2412 MHz)

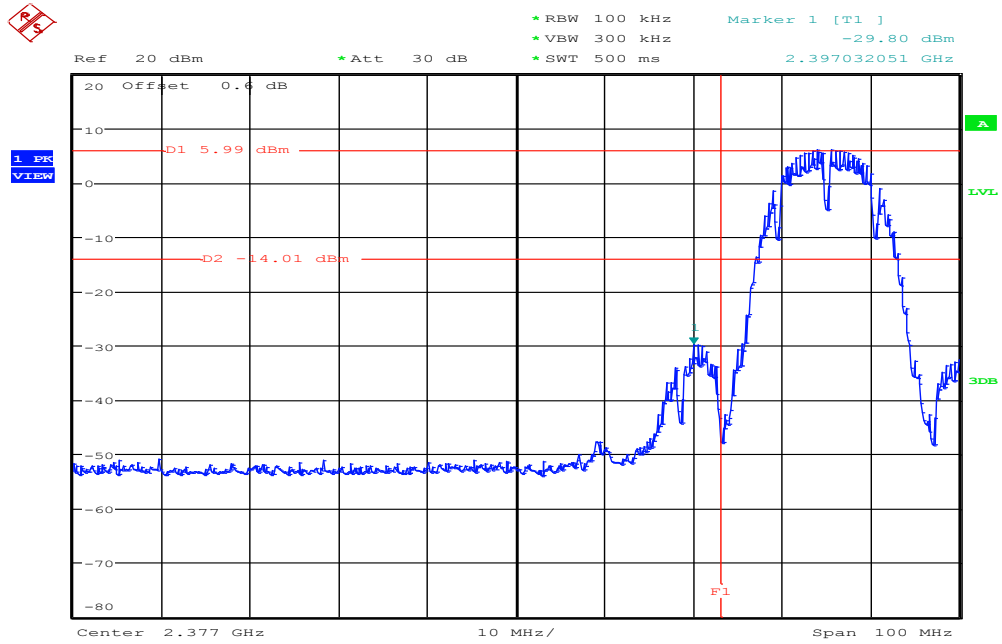

Date: 11.NOV.2015 00:00:05

Conducted Band Edges (IEEE 802.11b mode / 2462 MHz)

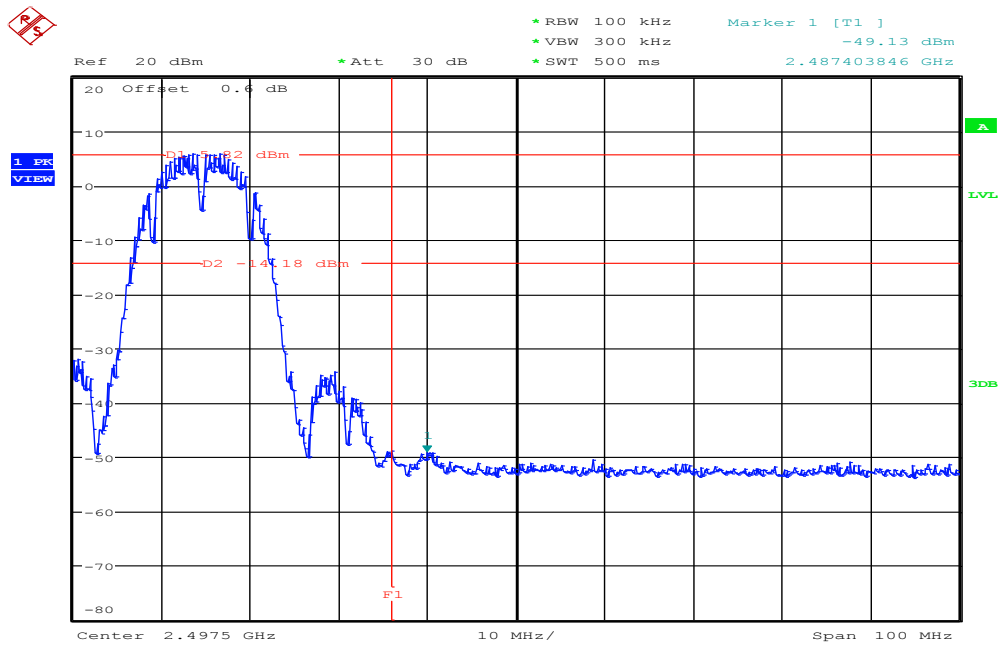

Date: 11.NOV.2015 00:11:30

Conducted Band Edges (IEEE 802.11g mode / 2412 MHz)

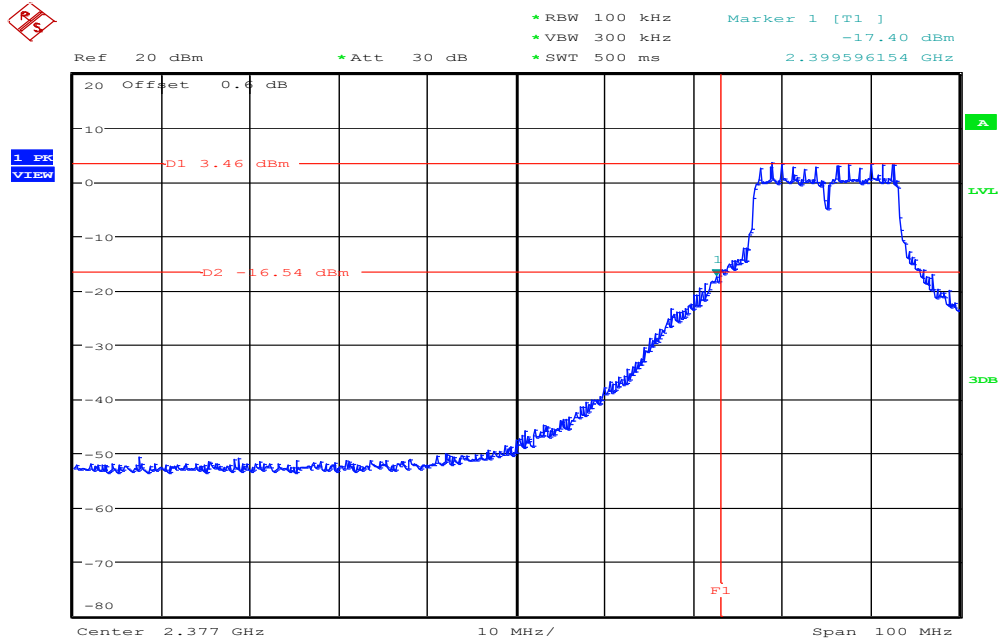

Date: 11.NOV.2015 00:22:02

Conducted Band Edges (IEEE 802.11g mode / 2462 MHz)

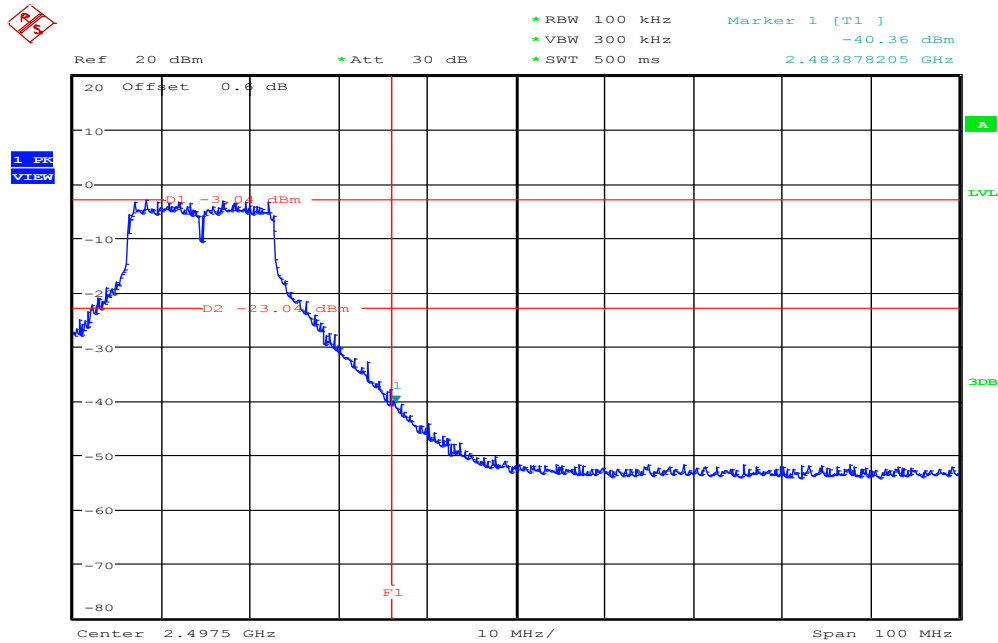

Date: 11.NOV.2015 00:34:05

Conducted Band Edges (IEEE 802.11n HT 20 MHz mode / 2412 MHz)

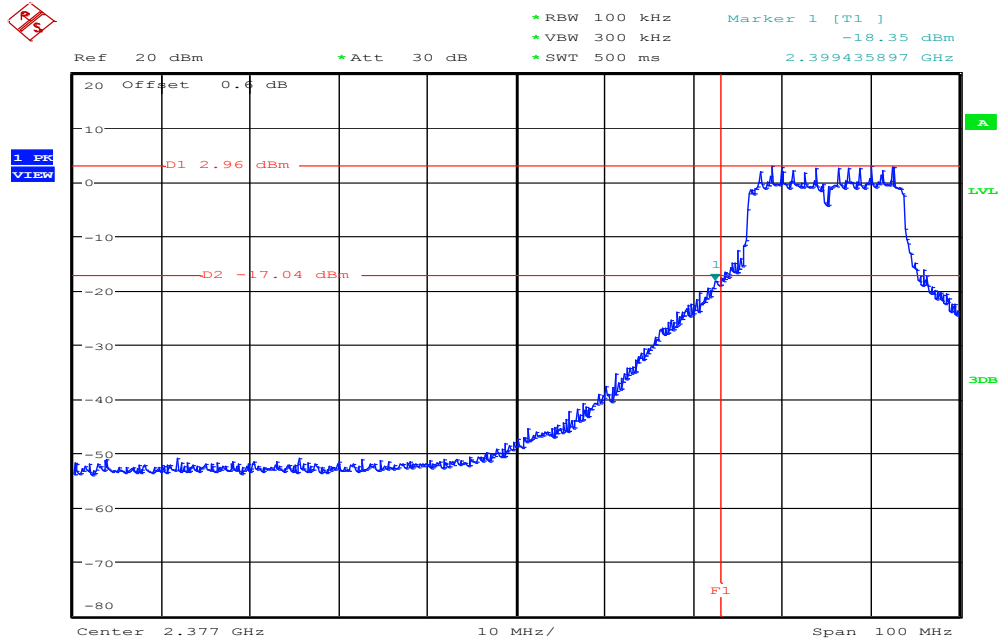

Date: 11.NOV.2015 00:41:52

Conducted Band Edges (IEEE 802.11n HT 20 MHz mode / 2462 MHz)

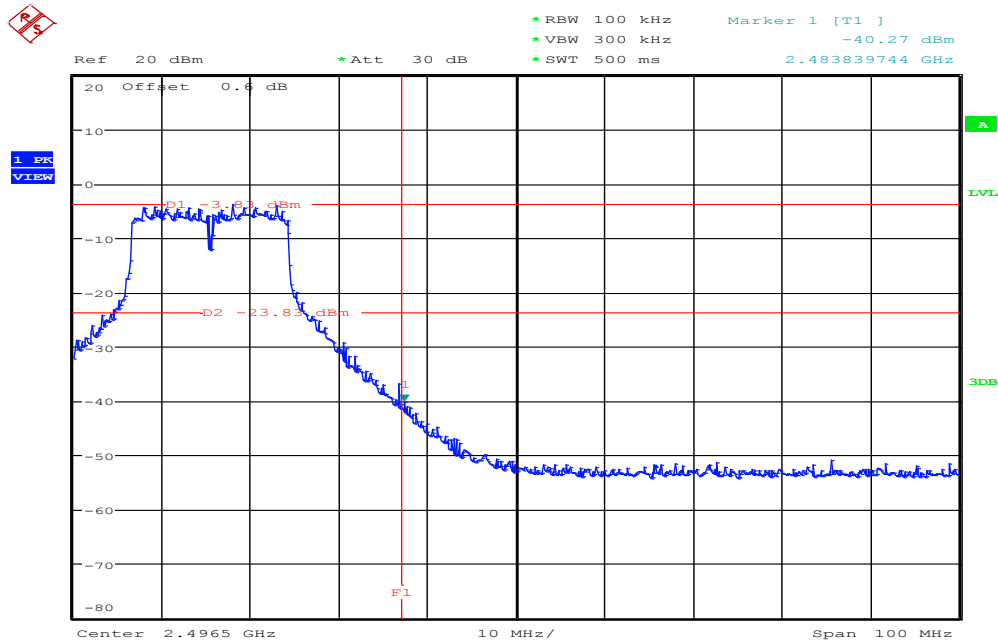

Date: 11.NOV.2015 00:50:32

Conducted Band Edges (IEEE 802.11n HT 40 MHz mode / 2422 MHz)

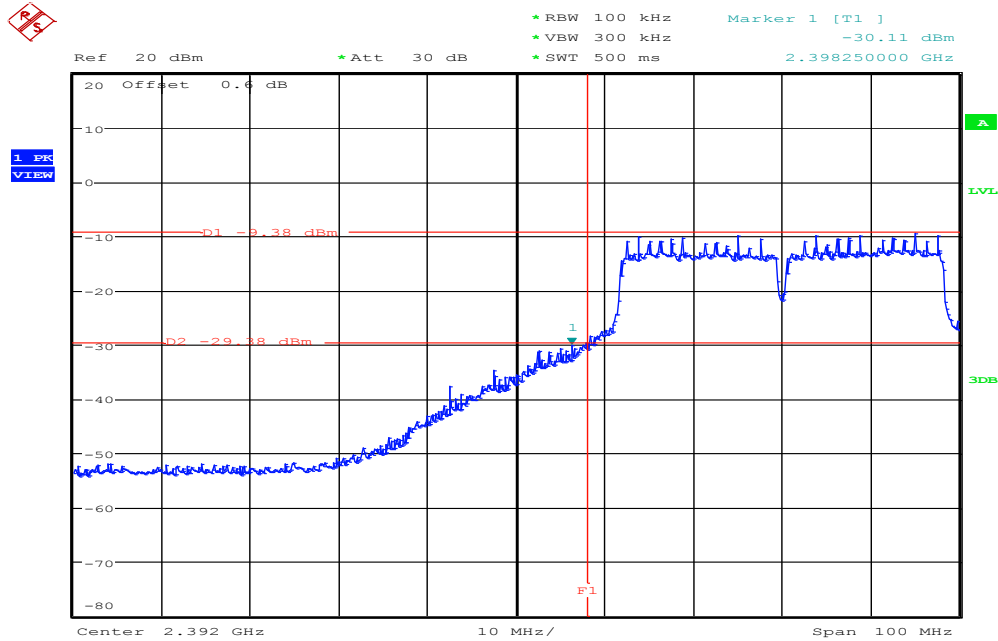

Date: 11.NOV.2015 01:27:50

Conducted Band Edges (IEEE 802.11n HT 40 MHz mode / 2452 MHz)

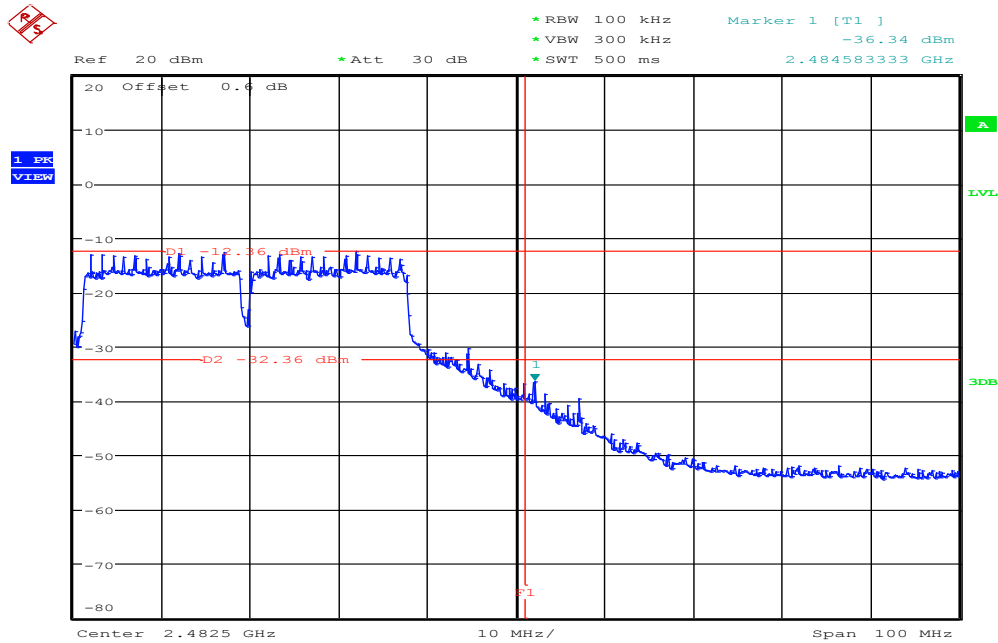

Date: 11.NOV.2015 01:14:53

7.5 PEAK POWER SPECTRAL DENSITY

LIMIT

1. According to §15.247(e), for digitally modulated systems, the power spectral density conducted from the intentional radiator to the antenna shall not be greater than 8 dBm in any 3 kHz band during any time interval of continuous transmission.
2. According to §15.247(f), the digital modulation operation of the hybrid system, with the frequency hopping turned off, shall comply with the power density requirements of paragraph (d) of this section.

Test Configuration

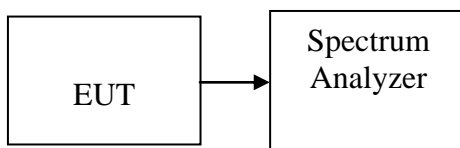

TEST PROCEDURE

The transmitter output is connected to a spectrum analyzer. Set the RBW = 3 kHz, VBW = 30 kHz, span to 1.5 times the DTS bandwidth, Detector = peak, Trace mode = max hold, Sweep = auto couple. Use the peak marker function to determine the maximum amplitude level within the RBW.

TEST RESULTS

No non-compliance noted

Test Data

Test mode: IEEE 802.11b mode

Frequency (MHz)	PPSD (dBm)	Limit (dBm)	Result
2412	-6.89	8.00	PASS
2437	-6.94		PASS
2462	-8.09		PASS

Test mode: IEEE 802.11g mode

Frequency (MHz)	PPSD (dBm)	Limit (dBm)	Result
2412	-9.02	8.00	PASS
2437	-8.02		PASS
2462	-15.10		PASS

Test mode: IEEE 802.11n HT 20 MHz mode

Frequency (MHz)	PPSD (dBm)	Limit (dBm)	Result
2412	-10.68	8.00	PASS
2437	-8.42		PASS
2462	-16.67		PASS

Test mode: IEEE 802.11n HT 40 MHz mode

Frequency (MHz)	PPSD (dBm)	Limit (dBm)	Result
2422	-23.90	8.00	PASS
2437	-11.31		PASS
2452	-27.37		PASS

Test Plot

IEEE 802.11b mode / 2412 MHz

PPSD

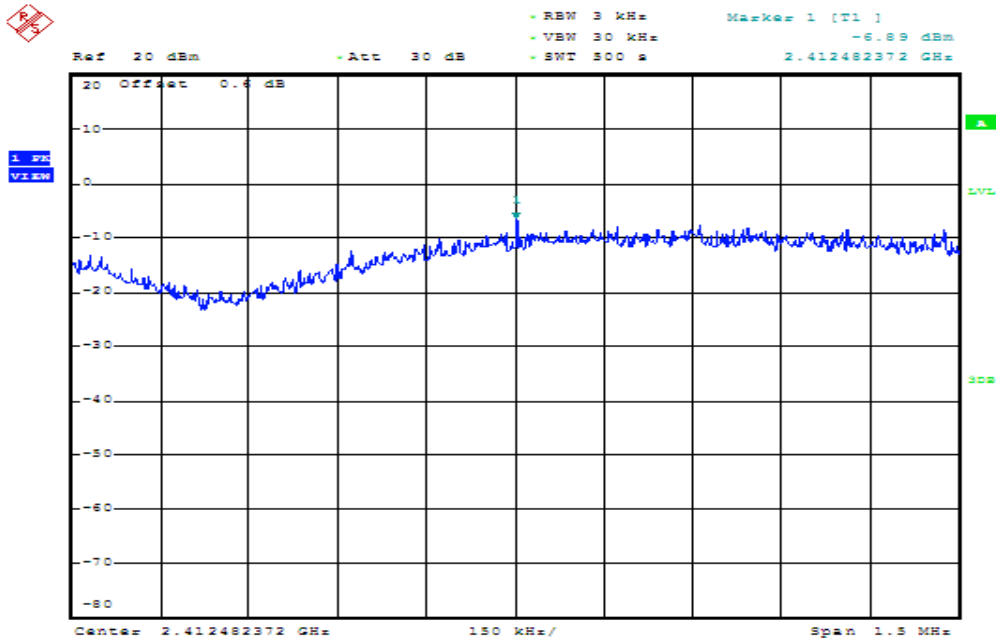

Date: 10.NOV.2015 23:56:20

IEEE 802.11b mode / 2437 MHz

PPSD

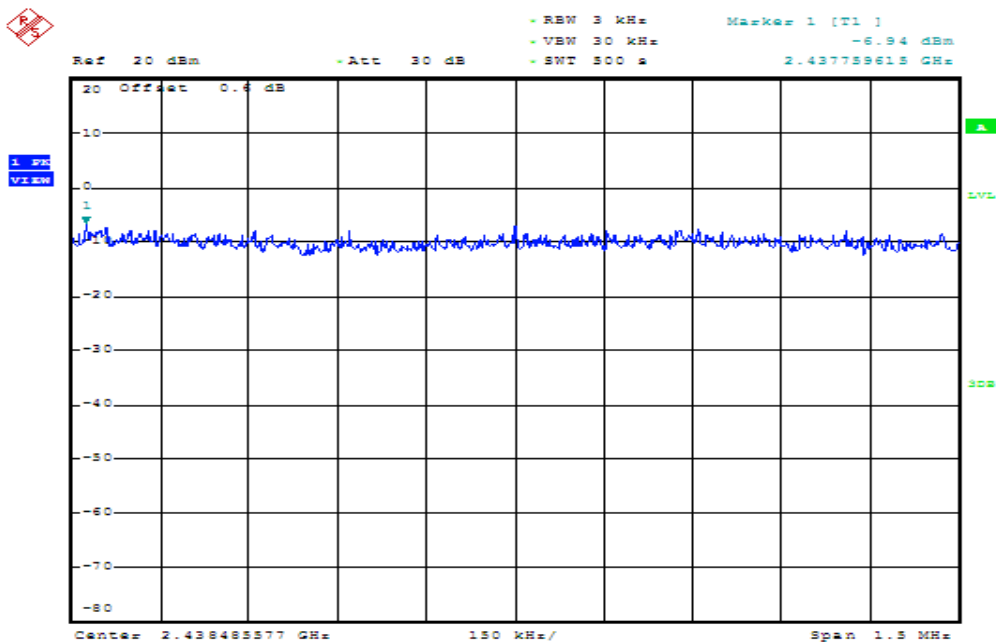

Date: 11.NOV.2015 00:06:00

IEEE 802.11b mode / 2462 MHz

PPSD

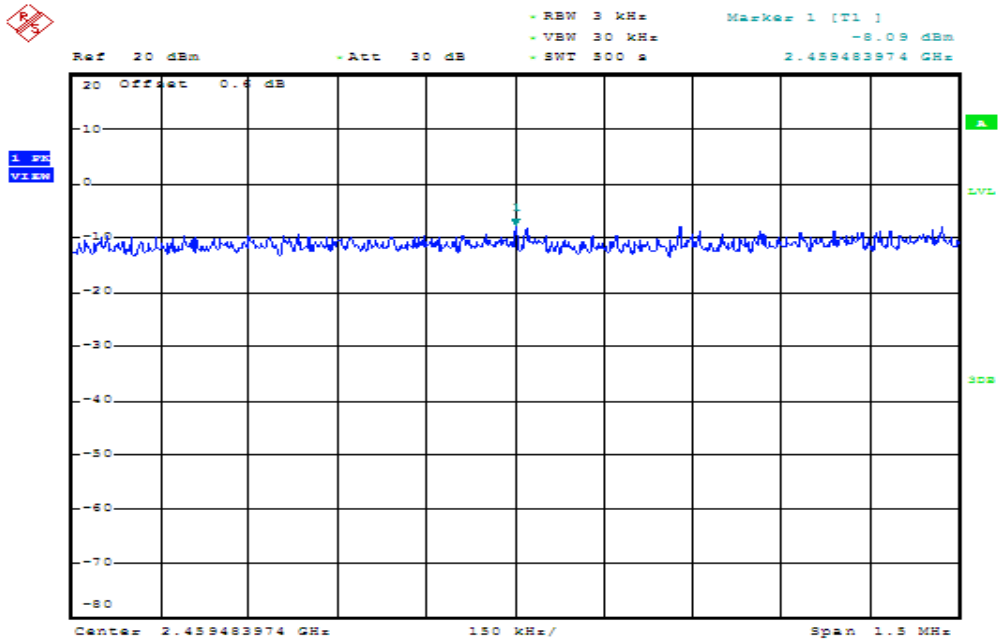

Date: 11.NOV.2015 00:10:00

IEEE 802.11g mode / 2412 MHz

PPSD

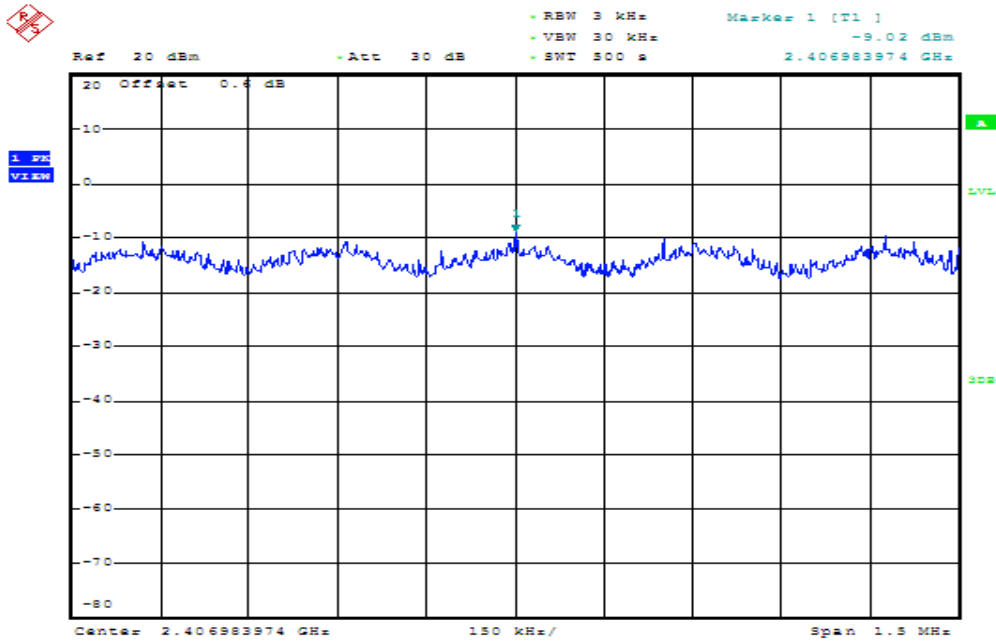

Date: 11.NOV.2015 00:19:46

IEEE 802.11g mode / 2437 MHz

PPSD

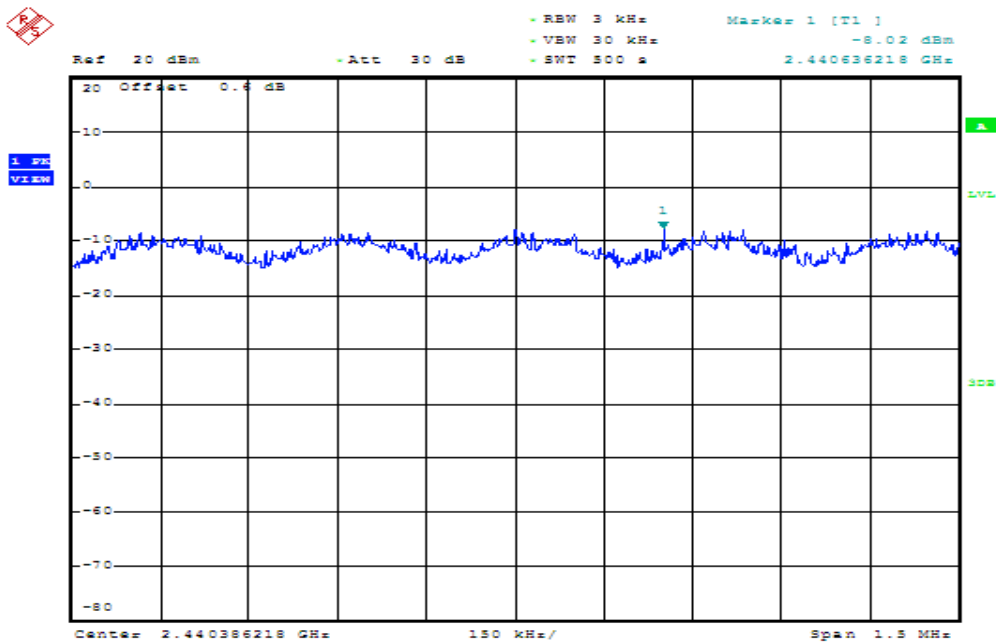

Date: 11.NOV.2015 00:28:23

IEEE 802.11g mode / 2462 MHz

PPSD

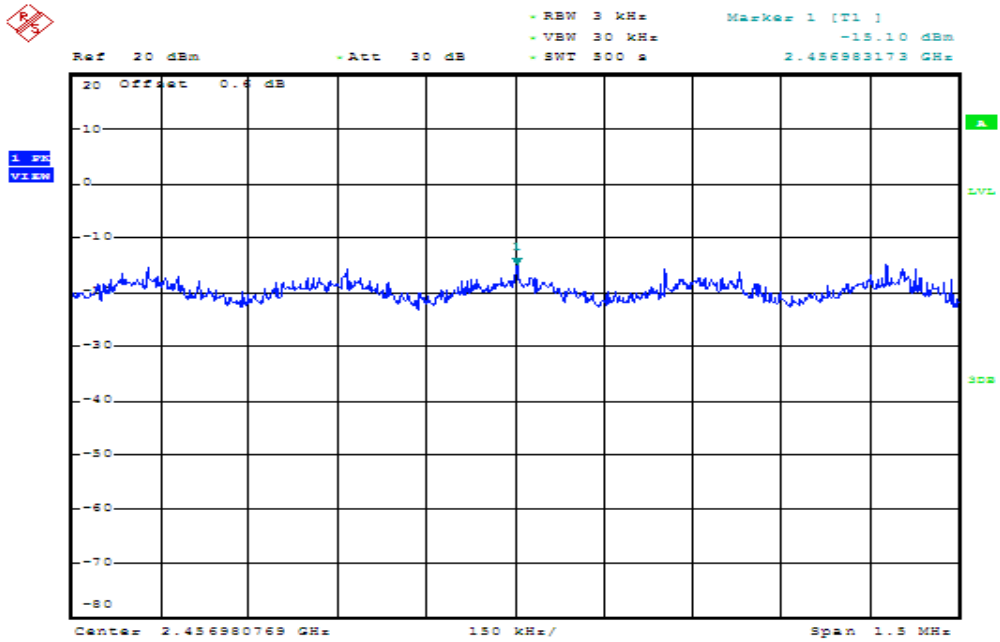

Date: 11.NOV.2015 00:32:36

IEEE 802.11n HT 20 MHz mode / 2412 MHz

PPSD

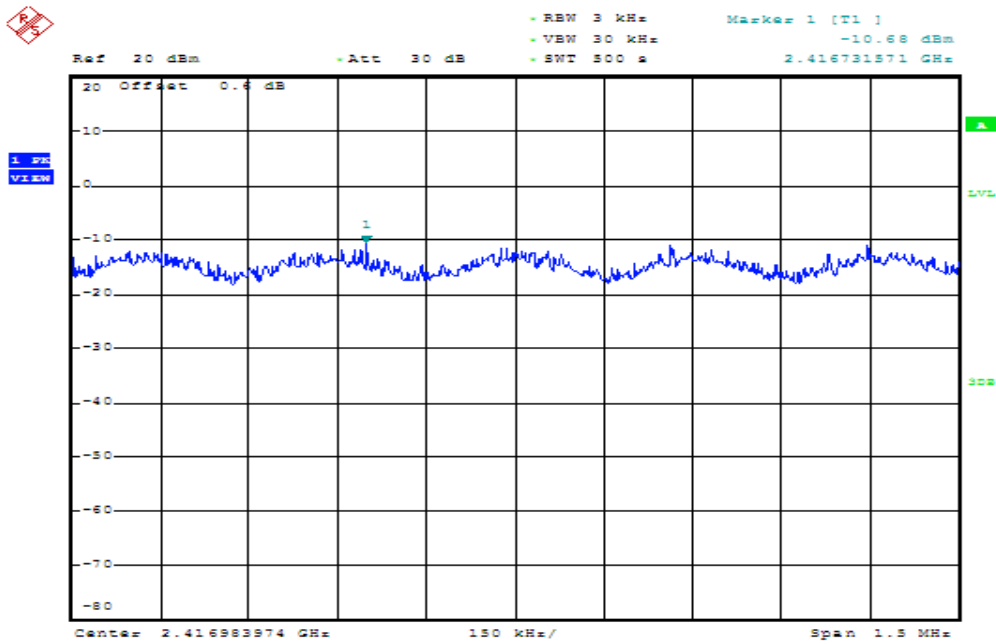

Date: 11.NOV.2015 00:40:29

IEEE 802.11n HT 20 MHz mode / 2437 MHz

PPSD

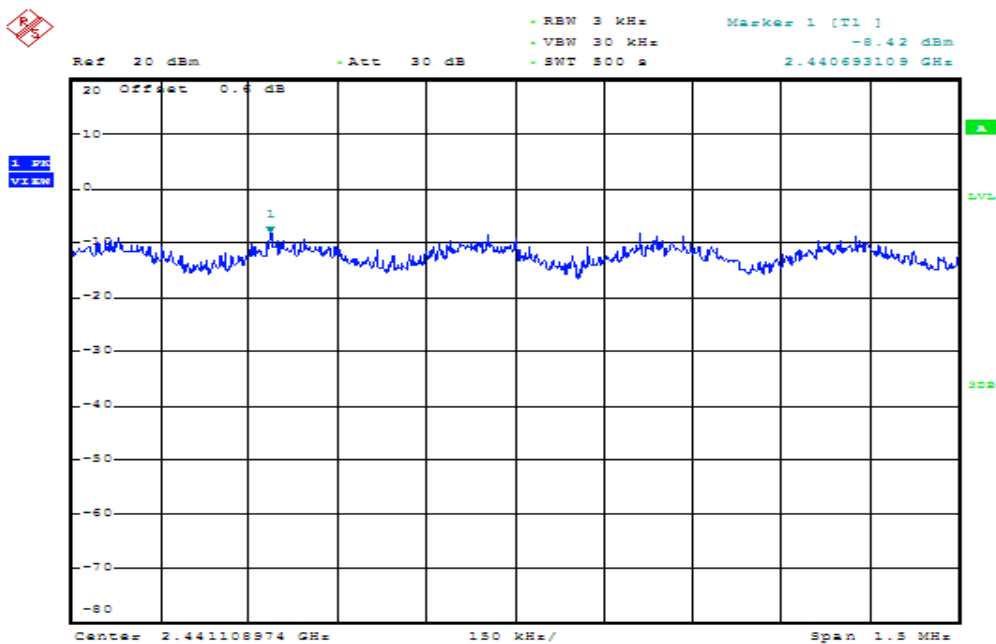

Date: 11.NOV.2015 00:45:48

IEEE 802.11n HT 20 MHz mode / 2462 MHz

PPSD

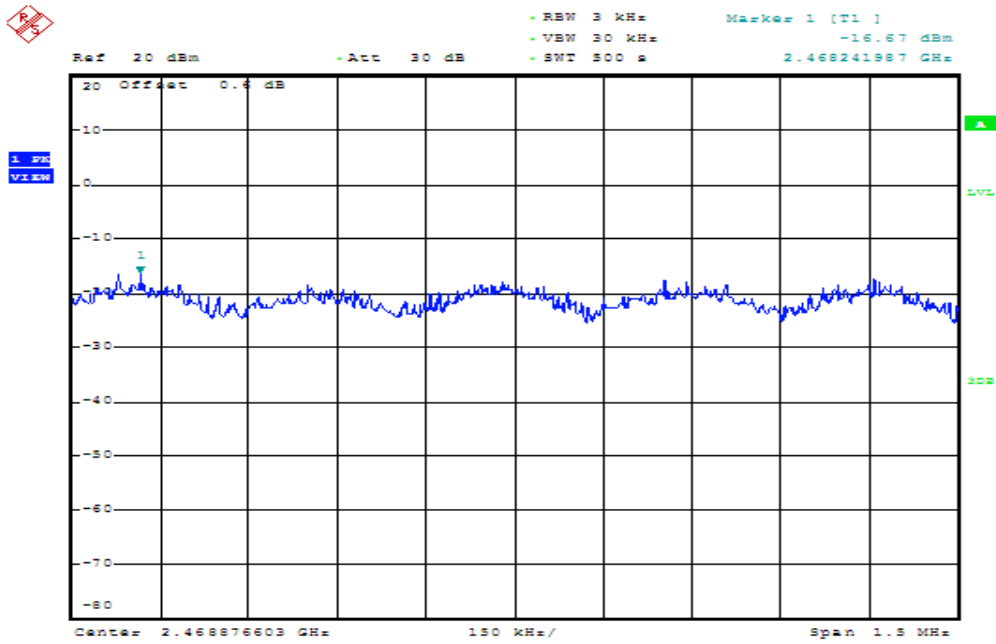

Date: 11.NOV.2015 00:49:23

IEEE 802.11n HT 40 MHz mode / 2422 MHz

PPSD

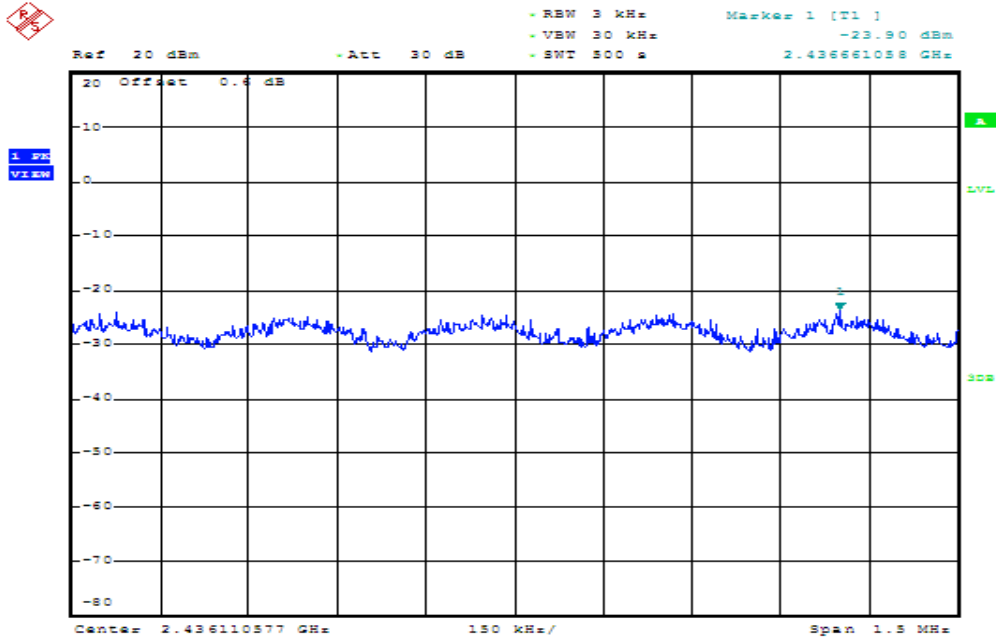

Date: 11.NOV.2015 01:34:54

IEEE 802.11n HT 40 MHz mode / 2437 MHz

PPSD

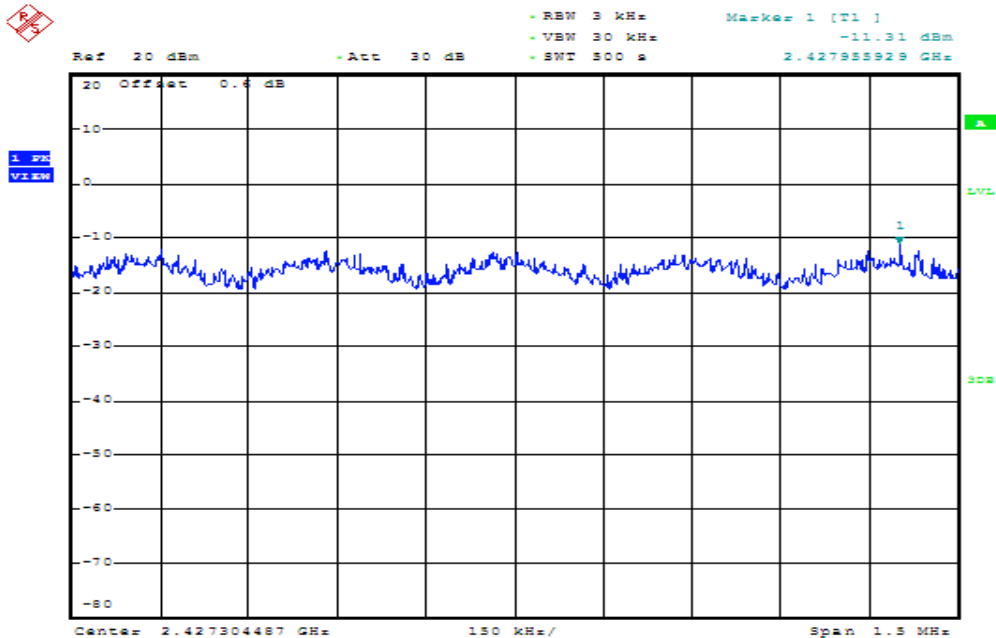

Date: 11.NOV.2015 01:08:53

IEEE 802.11n HT 40 MHz mode / 2452 MHz

PPSD

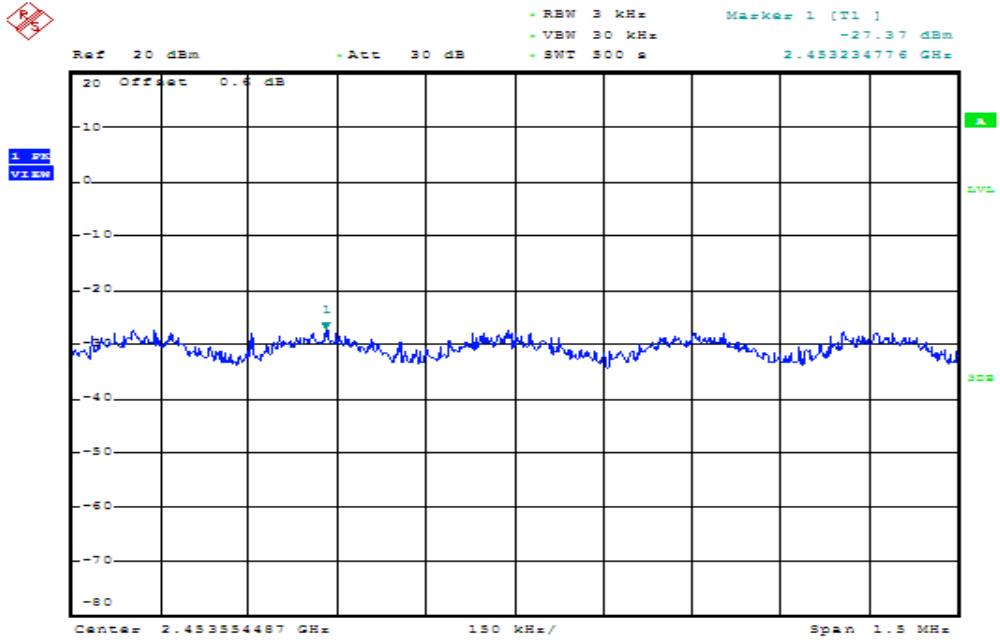

Date: 11.NOV.2015 01:13:49

7.6 RADIATED EMISSIONS

LIMIT

1. According to §15.209(a), except as provided elsewhere in this Subpart, the emissions from an intentional radiator shall not exceed the field strength levels specified in the following table:

Frequency (MHz)	Field Strength ($\mu\text{V/m}$)	Measurement Distance (m)
0.009 - 0.490	2400/F(kHz)	300
0.490 - 1.705	24000/F(kHz)	30
1.705 – 30.0	30	30
30-88	100	3
88-216	150	3
216-960	200	3
Above 960	500	3

Remark: Except as provided in paragraph (g), fundamental emissions from intentional radiators operating under this Section shall not be located in the frequency bands 54-72 MHz, 76-88 MHz, 174-216 MHz or 470-806 MHz. However, operation within these frequency bands is permitted under other sections of this Part, e.g., Sections 15.231 and 15.241.

2. In the emission table above, the tighter limit applies at the band edges.

Frequency (MHz)	Field Strength ($\mu\text{V/m}$ at 3-meter)	Field Strength (dB $\mu\text{V/m}$ at 3-meter)
0.009 - 0.490	2400/F(kHz) +80	20LOG((2400/F(kHz))+80)
0.490 - 1.705	24000/F(kHz) +40	20LOG((24000/F(kHz))+40)
1.705 – 30.0	30	69.54
30-88	100	40
88-216	150	43.5
216-960	200	46
Above 960	500	54

Test Configuration

9kHz ~ 30MHz

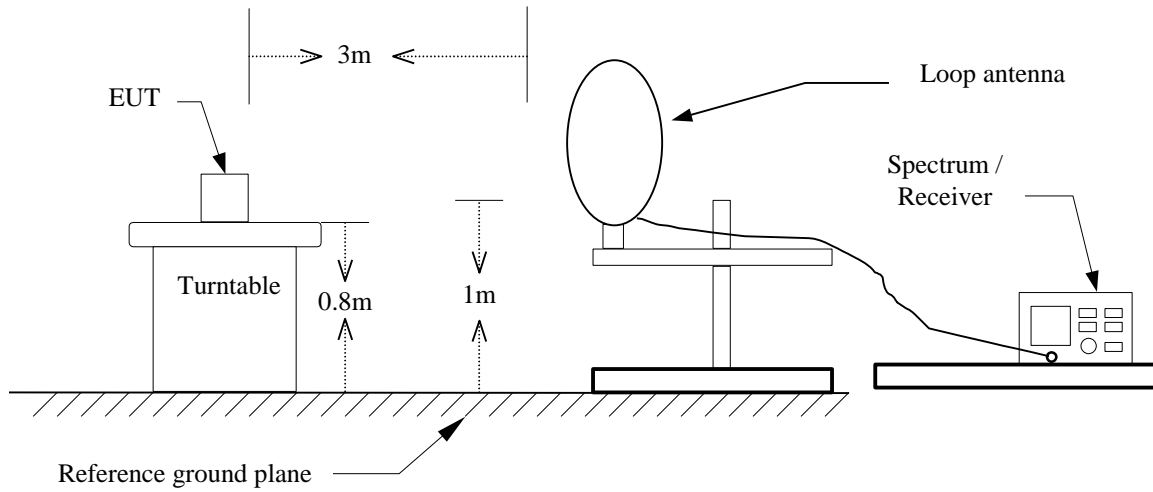

30MHz ~ 1GHz

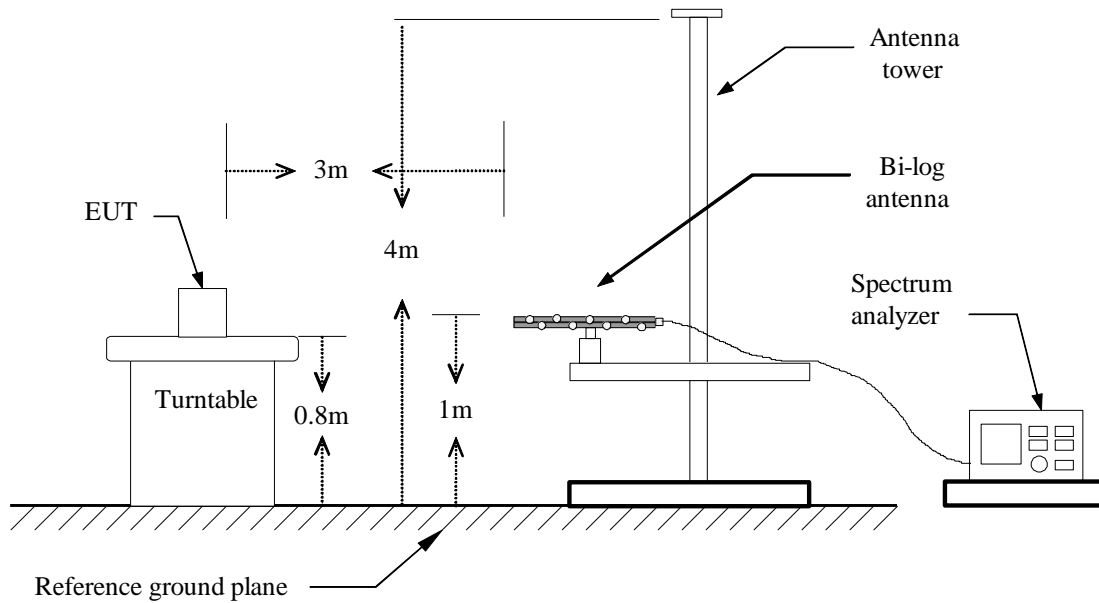

Above 1 GHz

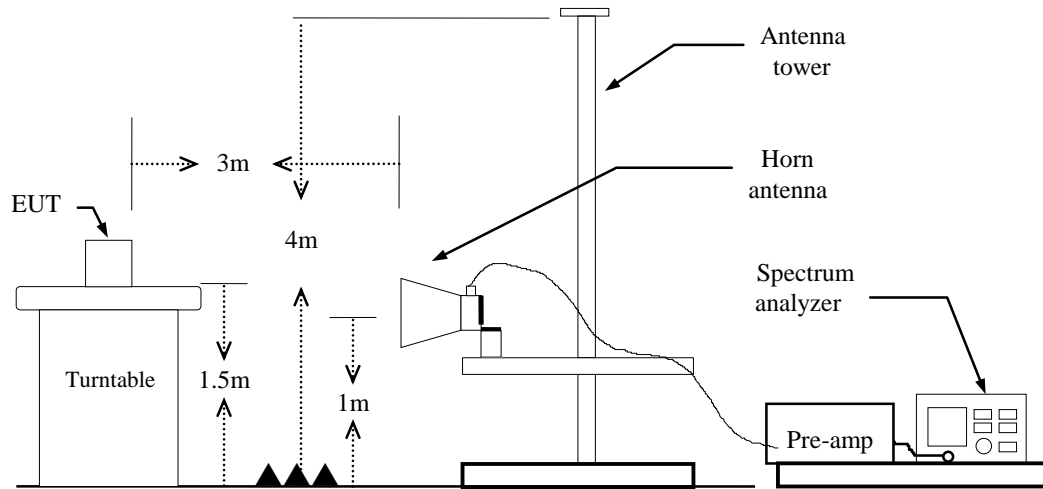

TEST PROCEDURE

1. The EUT is placed on a turntable, Above 1 GHz is 1.5m high and below 1 GHz is 0.8m high above ground plane.
2. The turntable shall be rotated for 360 degrees to determine the position of maximum emission level.
3. EUT is set 3m away from the receiving antenna, which is varied from 1m to 4m to find out the highest emissions.
4. Maximum procedure was performed on the six highest emissions to ensure EUT compliance.
5. And also, each emission was to be maximized by changing the polarization of receiving antenna both horizontal and vertical.
6. Set the spectrum analyzer in the following setting as:

Below 1GHz:

RBW=100kHz / VBW=300kHz / Sweep=AUTO

Above 1GHz:

(a) PEAK: RBW: 1MHz / VBW: 3MHz / Sweep=AUTO

(b) AVERAGE: RBW=1MHz,
if duty cycle \geq 98%, VBW=10Hz.
if duty cycle < 98% VBW=1/T.

IEEE 802.11b mode: \geq 98%, VBW=10Hz

IEEE 802.11g mode: \geq 98%, VBW=10Hz

IEEE 802.11n HT 20 MHz mode: \geq 98%, VBW=10Hz

IEEE 802.11n HT 40 MHz mode: \geq 98%, VBW=10Hz

7. Repeat above procedures until the measurements for all frequencies are complete.
8. Result = Spectrum Reading + cable loss(spectrum to Amp) - Amp Gain + Cable loss(Amp to receive Ant)+ Receive Ant

Note: We checked every harmonics frequencies from Fundamental frequencies with reduced VBW, and we mark a point to prove pass or not if we find any emission. For this case, there are no emissions hidden in the noise floor.

TEST RESULTS

Below 1GHz

Operation Mode: Normal Link

Test Date: December 18, 2015

Temperature: 27°C

Tested by: Jason Lu

Humidity: 53% RH

Polarity: Ver.

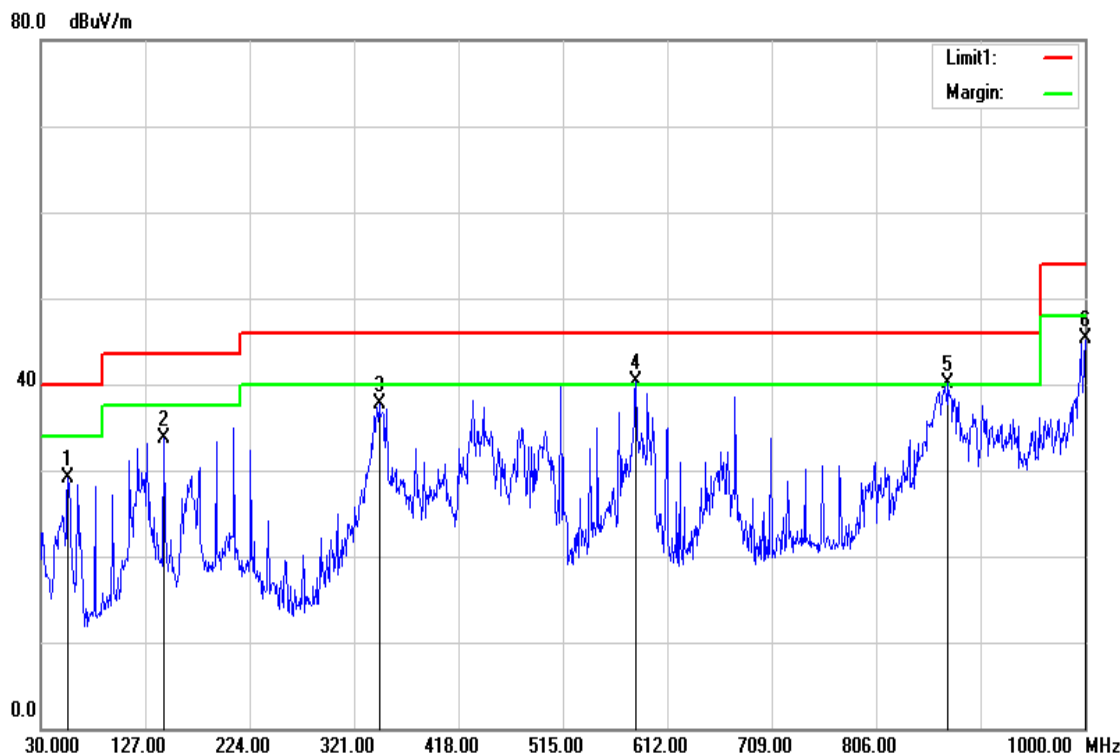

Frequency (MHz)	Reading (dBuV)	Correction Factor (dB/m)	Result (dBuV/m)	Limit (dBuV/m)	Margin (dB)	Remark	Ant. Pol. (H/V)
55.2200	50.66	-21.61	29.05	40.00	-10.95	peak	V
144.4600	49.70	-15.91	33.79	43.50	-9.71	peak	V
344.2800	50.67	-13.04	37.63	46.00	-8.37	peak	V
582.9000	48.26	-8.01	40.25	46.00	-5.75	peak	V
872.9300	43.53	-3.51	40.02	46.00	-5.98	peak	V
1000.0000	46.93	-1.58	45.35	54.00	-8.65	peak	V

Remark:

1. No emission found between lowest internal used/generated frequency to 30MHz (9kHz~30MHz)
2. Radiated emissions measured in frequency range from 30 MHz to 1000MHz were made with an instrument using peak/quasi-peak detector mode.
3. Quasi-peak test would be performed if the peak result were greater than the quasi-peak limit or as required by the applicant.
4. Measurements above show only up to 6 maximum emissions noted, or would be lesser, with " N/A " remark, if no specific emissions from the EUT are recorded (ie: margin>20dB from the applicable limit) and considered that's already beyond the background noise floor.
5. Margin (dB) = Result (dBuV/m) – Limit (dBuV/m).

Operation Mode: Normal Link
Temperature: 27°C
Humidity: 53% RH

Test Date: December 18, 2015
Tested by: Jason Lu
Polarity: Hor.

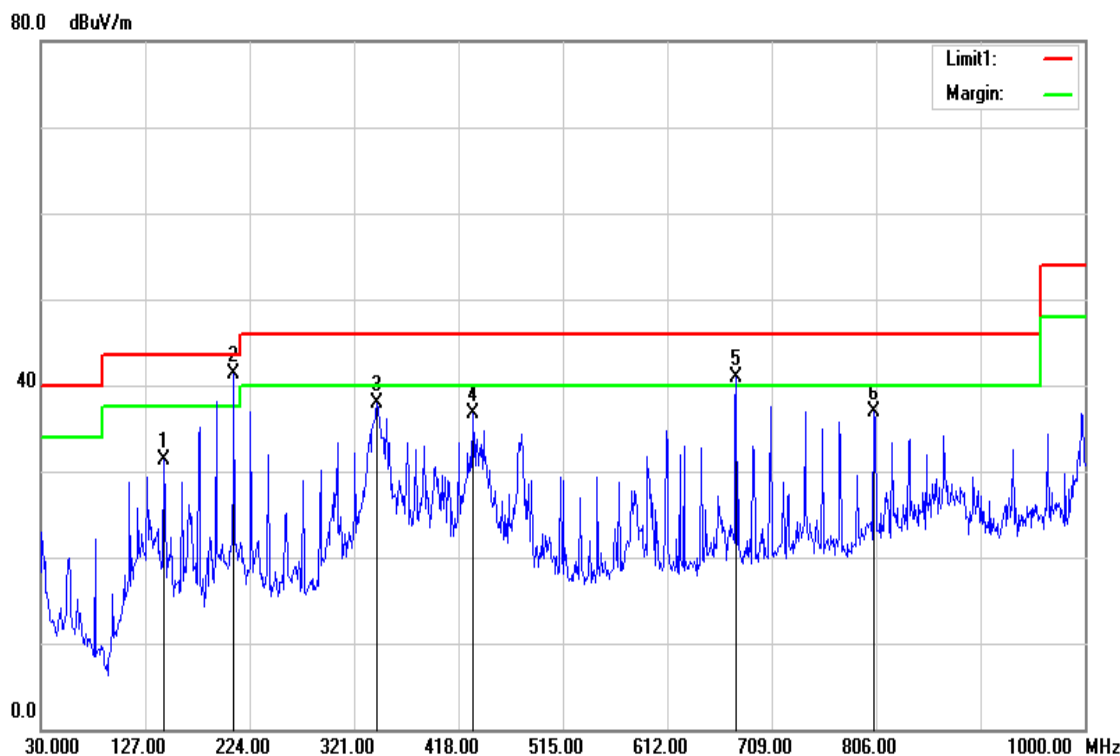

Frequency (MHz)	Reading (dBuV)	Correction Factor (dB/m)	Result (dBuV/m)	Limit (dBuV/m)	Margin (dB)	Remark	Ant. Pol. (H/V)
144.4600	47.30	-15.91	31.39	43.50	-12.11	peak	H
209.4500	57.43	-16.22	41.21	43.50	-2.29	peak	H
342.3400	51.03	-13.10	37.93	46.00	-8.07	peak	H
431.5800	47.54	-10.75	36.79	46.00	-9.21	peak	H
676.0200	47.29	-6.31	40.98	46.00	-5.02	peak	H
804.0600	41.29	-4.44	36.85	46.00	-9.15	peak	H

Remark:

1. No emission found between lowest internal used/generated frequency to 30MHz (9kHz~30MHz)
2. Radiated emissions measured in frequency range from 30 MHz to 1000MHz were made with an instrument using peak/quasi-peak detector mode.
3. Quasi-peak test would be performed if the peak result were greater than the quasi-peak limit or as required by the applicant.
4. Measurements above show only up to 6 maximum emissions noted, or would be lesser, with " N/A " remark, if no specific emissions from the EUT are recorded (ie: margin>20dB from the applicable limit) and considered that's already beyond the background noise floor.
5. Margin (dB) = Result (dBuV/m) – Limit (dBuV/m).

Above 1 GHz

TX / IEEE 802.11b / 2412 MHz

Polarity: Vertical

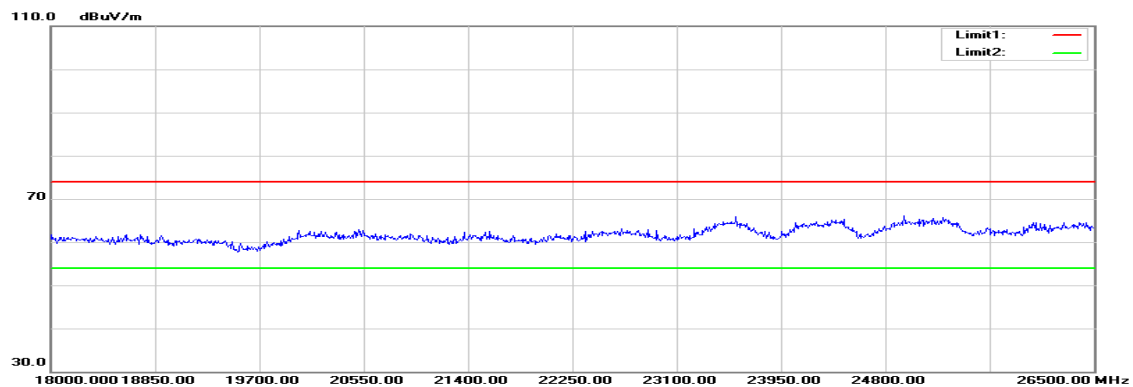
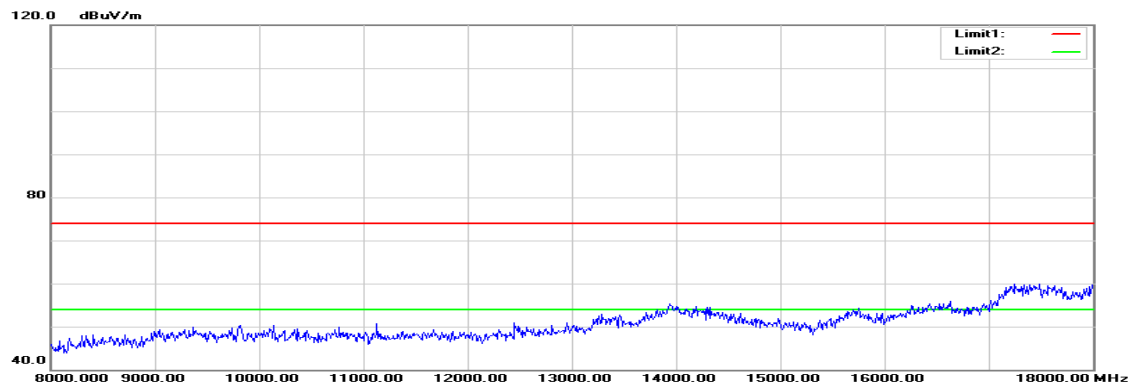
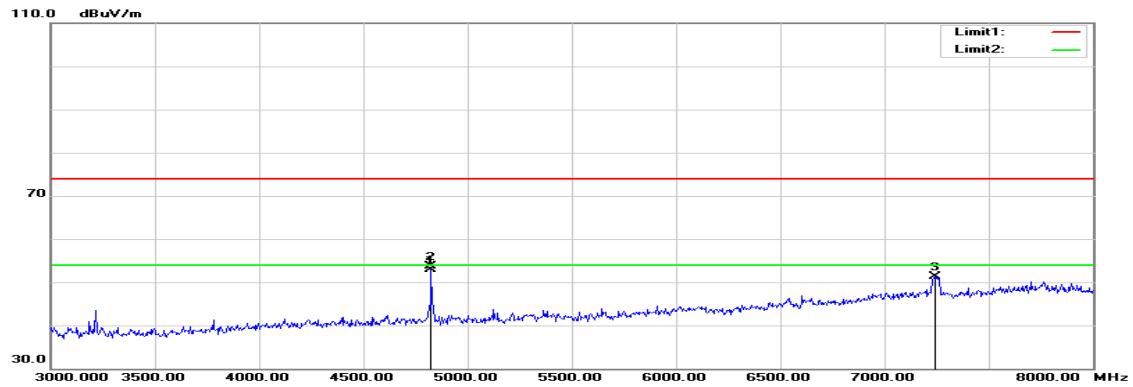
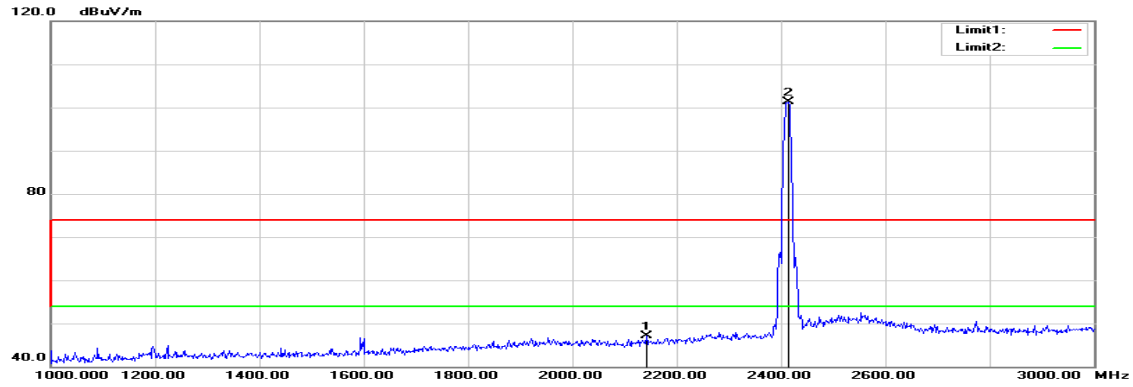

Polarity: Horizontal

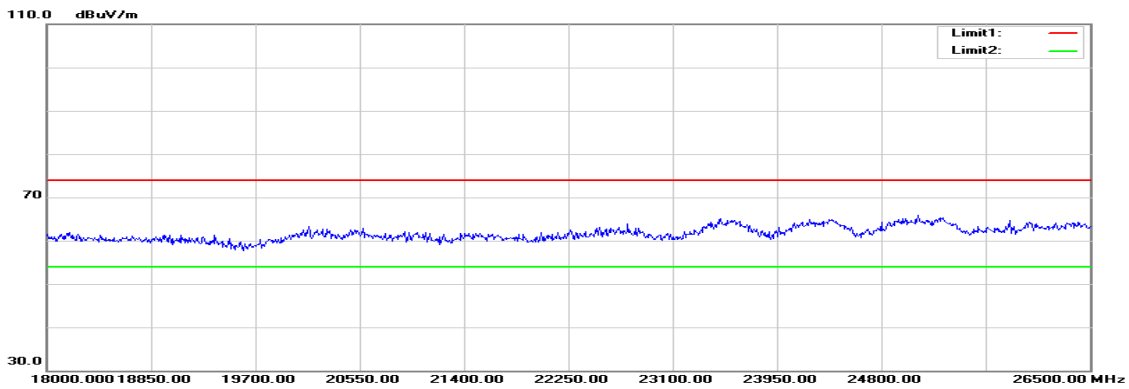
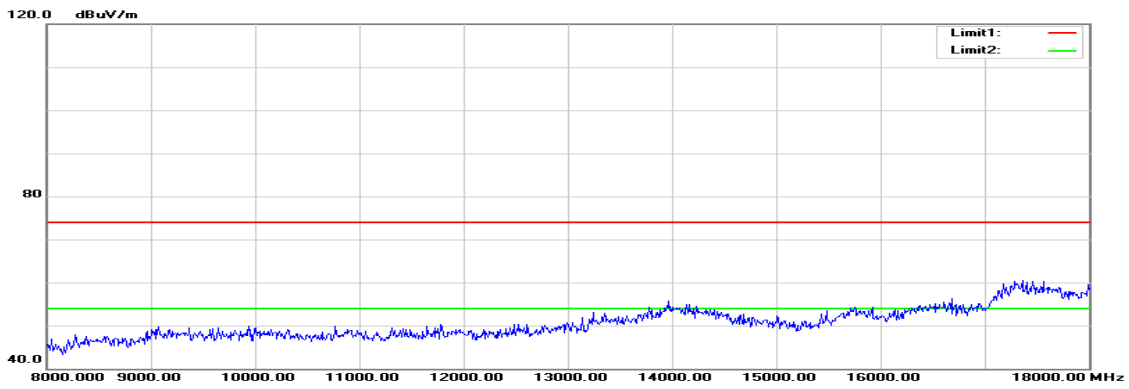
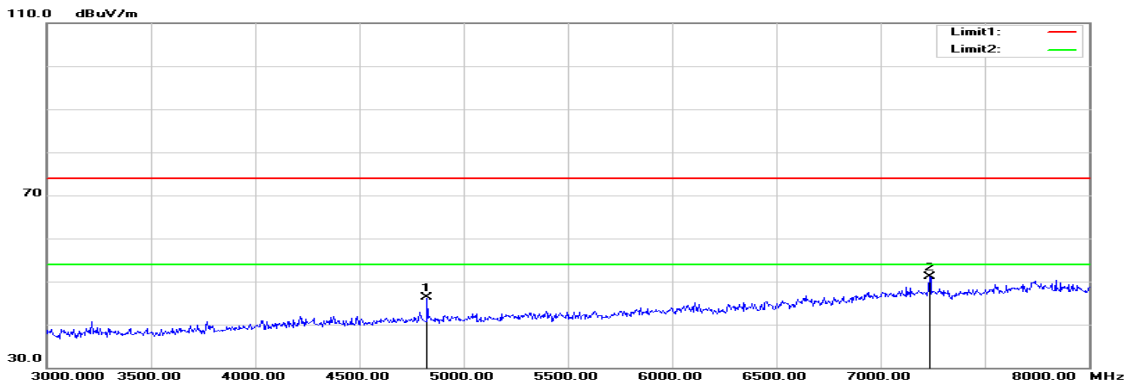
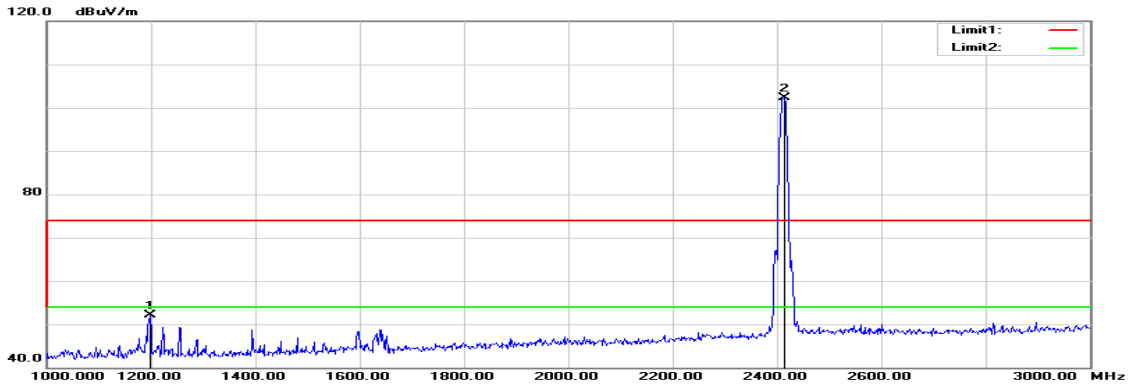

Above 1 GHz

Operation Mode: TX / IEEE 802.11b / 2412 MHz

Test Date: November 11, 2015

Temperature: 27°C

Tested by: Jason Lu

Humidity: 53% RH

Polarity: Ver. / Hor.

Frequency (MHz)	Reading (dBuV)	Correction (dB/m)	Result (dBuV/m)	Limit (dBuV/m)	Margin (dB)	Remark	Ant.Pol. (H/V)
2142.000	50.62	-3.47	47.15	74.00	-26.85	peak	V
4825.000	47.76	5.10	52.86	74.00	-21.14	peak	V
4825.000	48.65	5.10	53.75	54.00	-0.25	AVG	V
7245.000	38.61	12.74	51.35	74.00	-22.65	peak	V
N/A							
1198.000	59.40	-7.25	52.15	74.00	-21.85	peak	H
4825.000	41.10	5.10	46.20	74.00	-27.80	peak	H
7235.000	38.32	12.71	51.03	74.00	-22.97	peak	H
N/A							

Remark:

1. Measuring frequencies from 1 GHz to the 10th harmonic of highest fundamental frequency.
2. Radiated emissions measured in frequency above 1000MHz were made with an instrument using peak/average detector mode.
3. Average test would be performed if the peak result were greater than the average limit or as required by the applicant.
4. Data of measurement within this frequency range shown " --- " in the table above means the reading of emissions are attenuated more than 20dB below the permissible limits or the field strength is too small to be measured.
5. Measurements above show only up to 6 maximum emissions noted, or would be lesser, with " N/A " remark, if no specific emissions from the EUT are recorded (ie: margin>20dB from the applicable limit) and considered that's already beyond the background noise floor.
6. Margin (dB) = Result (dBuV/m) – limit (dBuV/m).

TX / IEEE 802.11b / 2437 MHz

Polarity: Vertical

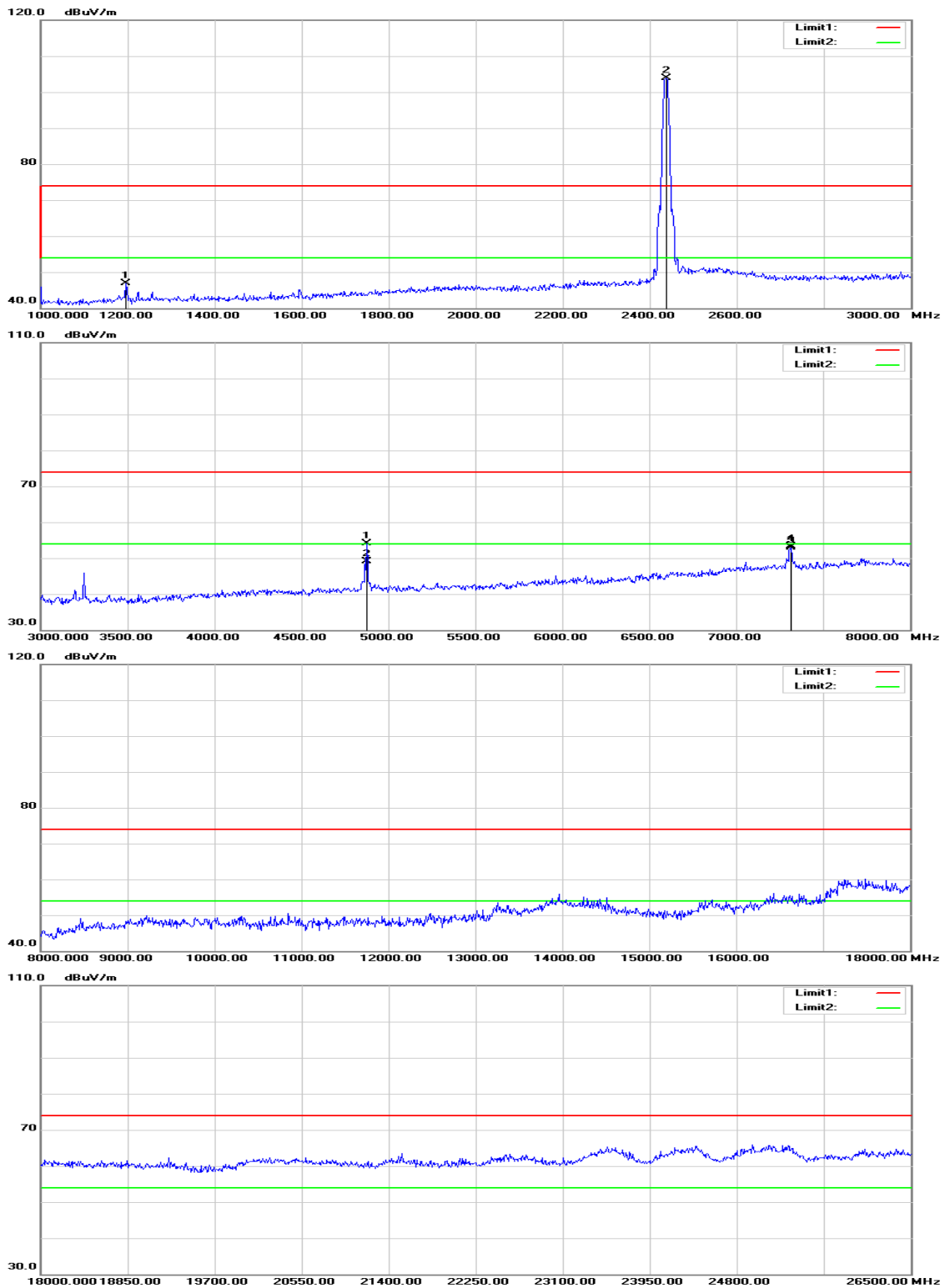

Polarity: Horizontal

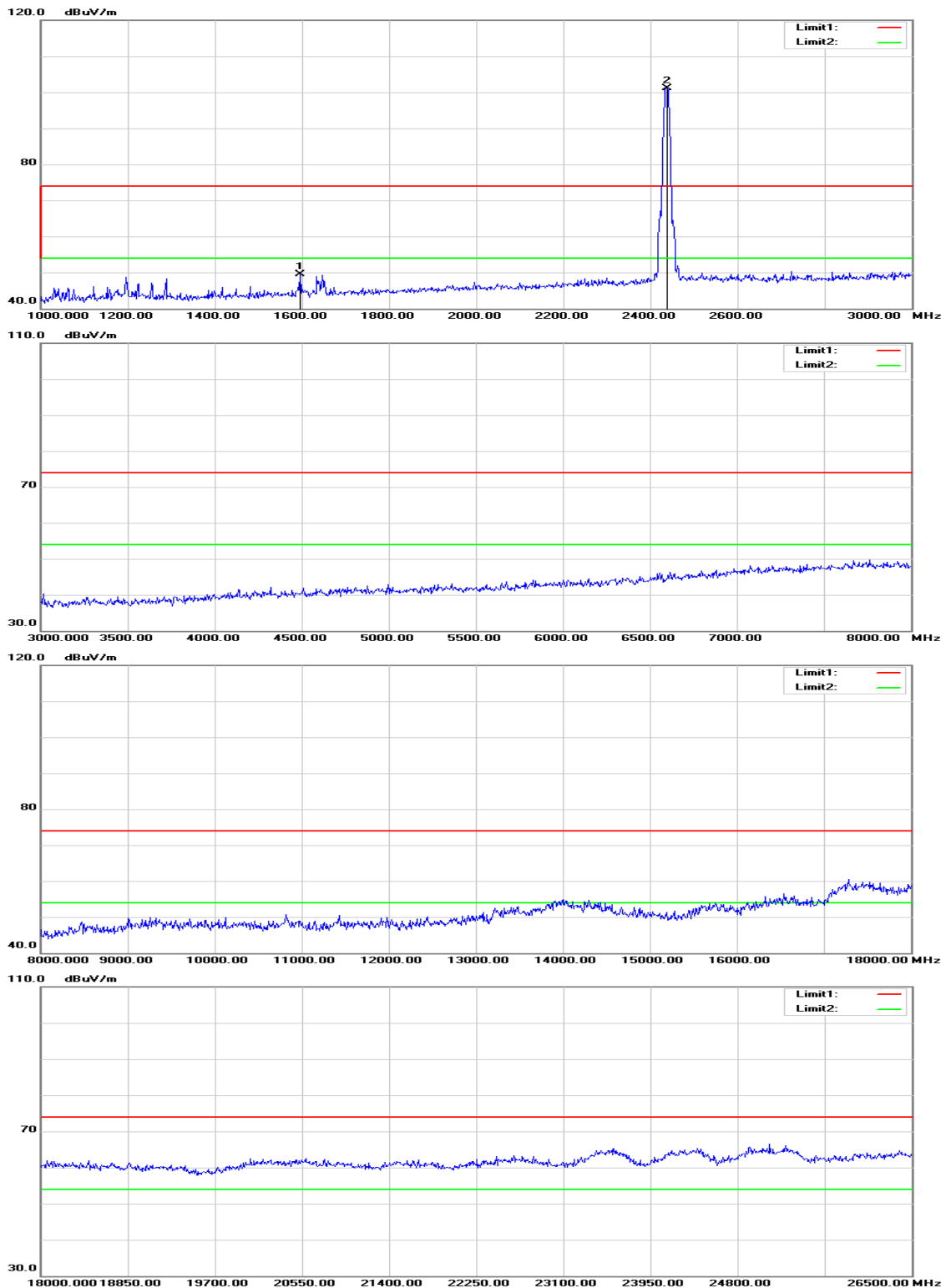

Operation Mode: TX / IEEE 802.11b / 2437 MHz

Test Date: November 11, 2015

Temperature: 27°C

Tested by: Jason Lu

Humidity: 53% RH

Polarity: Ver. / Hor.

Frequency (MHz)	Reading (dBuV)	Correction (dB/m)	Result (dBuV/m)	Limit (dBuV/m)	Margin (dB)	Remark	Ant.Pol. (H/V)
1196.000	54.18	-7.25	46.93	74.00	-27.07	peak	V
4875.000	48.77	5.24	54.01	74.00	-19.99	peak	V
4875.000	43.95	5.24	49.19	54.00	-4.81	AVG	V
7315.000	39.93	12.95	52.88	74.00	-21.12	peak	V
7315.000	40.33	12.95	53.28	54.00	-0.72	AVG	V
N/A							
1596.000	55.24	-5.69	49.55	74.00	-24.45	peak	H
N/A							

Remark:

1. Measuring frequencies from 1 GHz to the 10th harmonic of highest fundamental frequency.
2. Radiated emissions measured in frequency above 1000MHz were made with an instrument using peak/average detector mode.
3. Average test would be performed if the peak result were greater than the average limit or as required by the applicant.
4. Data of measurement within this frequency range shown " --- " in the table above means the reading of emissions are attenuated more than 20dB below the permissible limits or the field strength is too small to be measured.
5. Measurements above show only up to 6 maximum emissions noted, or would be lesser, with " N/A " remark, if no specific emissions from the EUT are recorded (ie: margin>20dB from the applicable limit) and considered that's already beyond the background noise floor.
6. Margin (dB) = Result (dBuV/m) – limit (dBuV/m).

TX / IEEE 802.11b / 2462 MHz

Polarity: Vertical

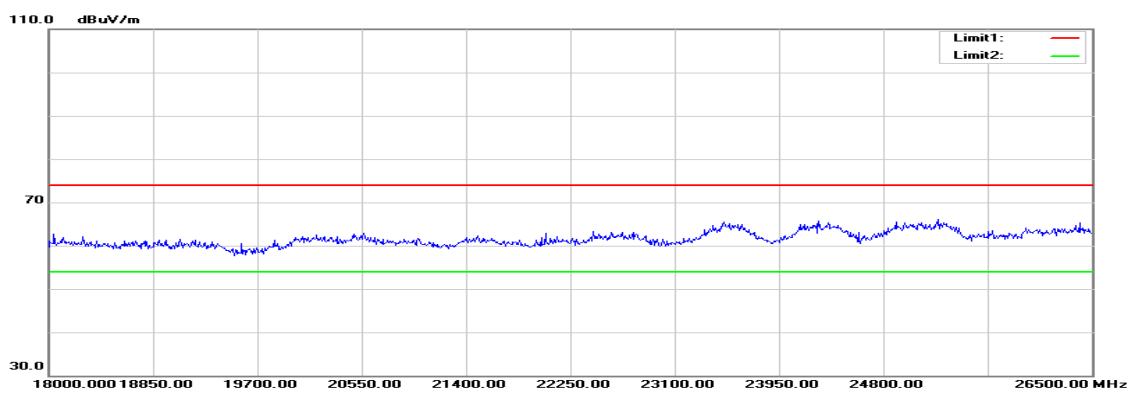
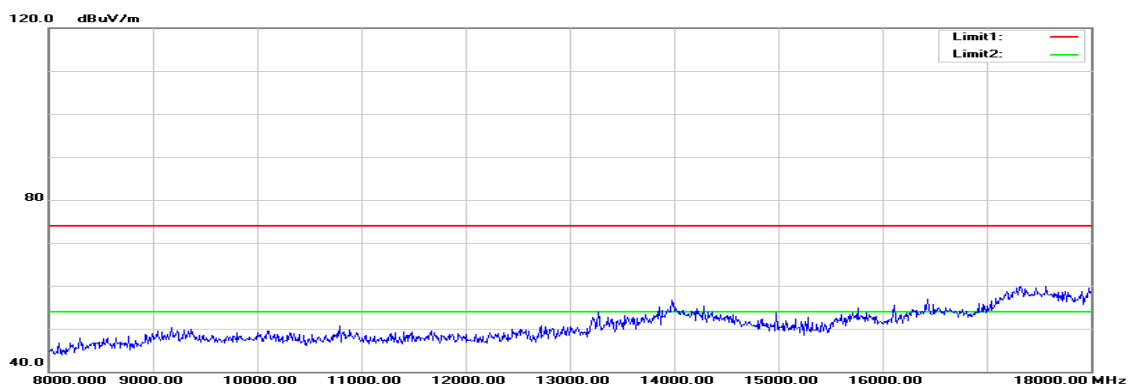
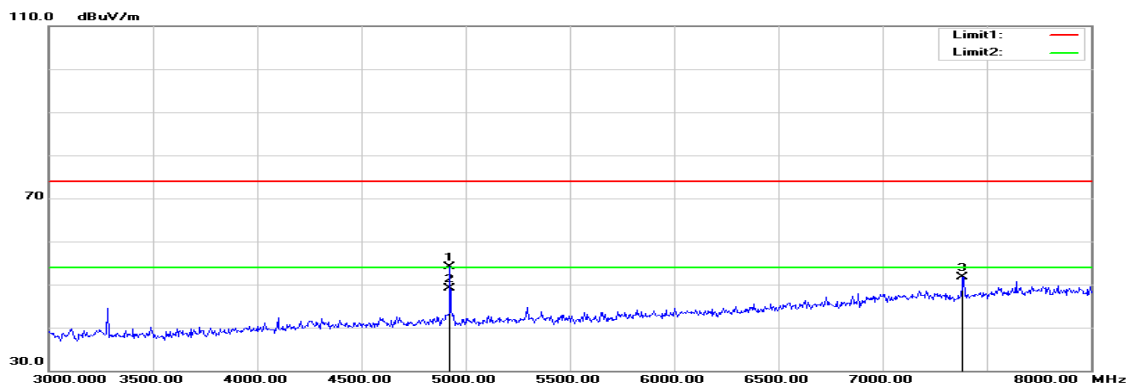
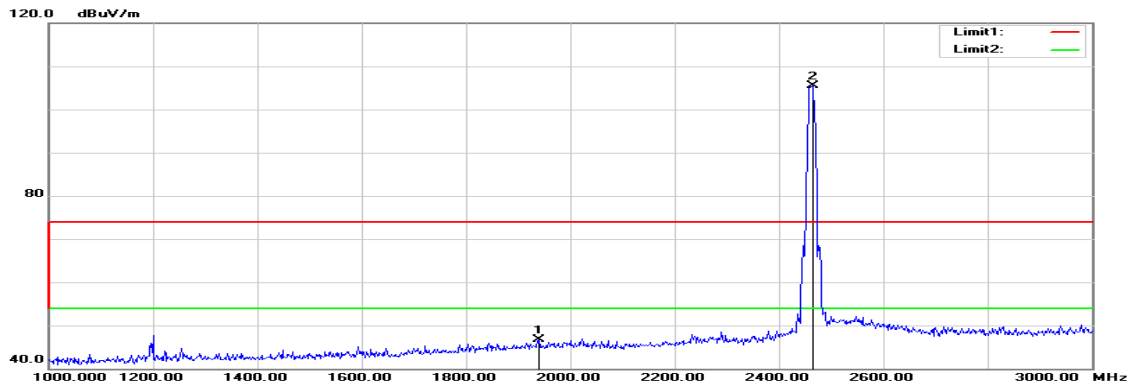

Polarity: Horizontal

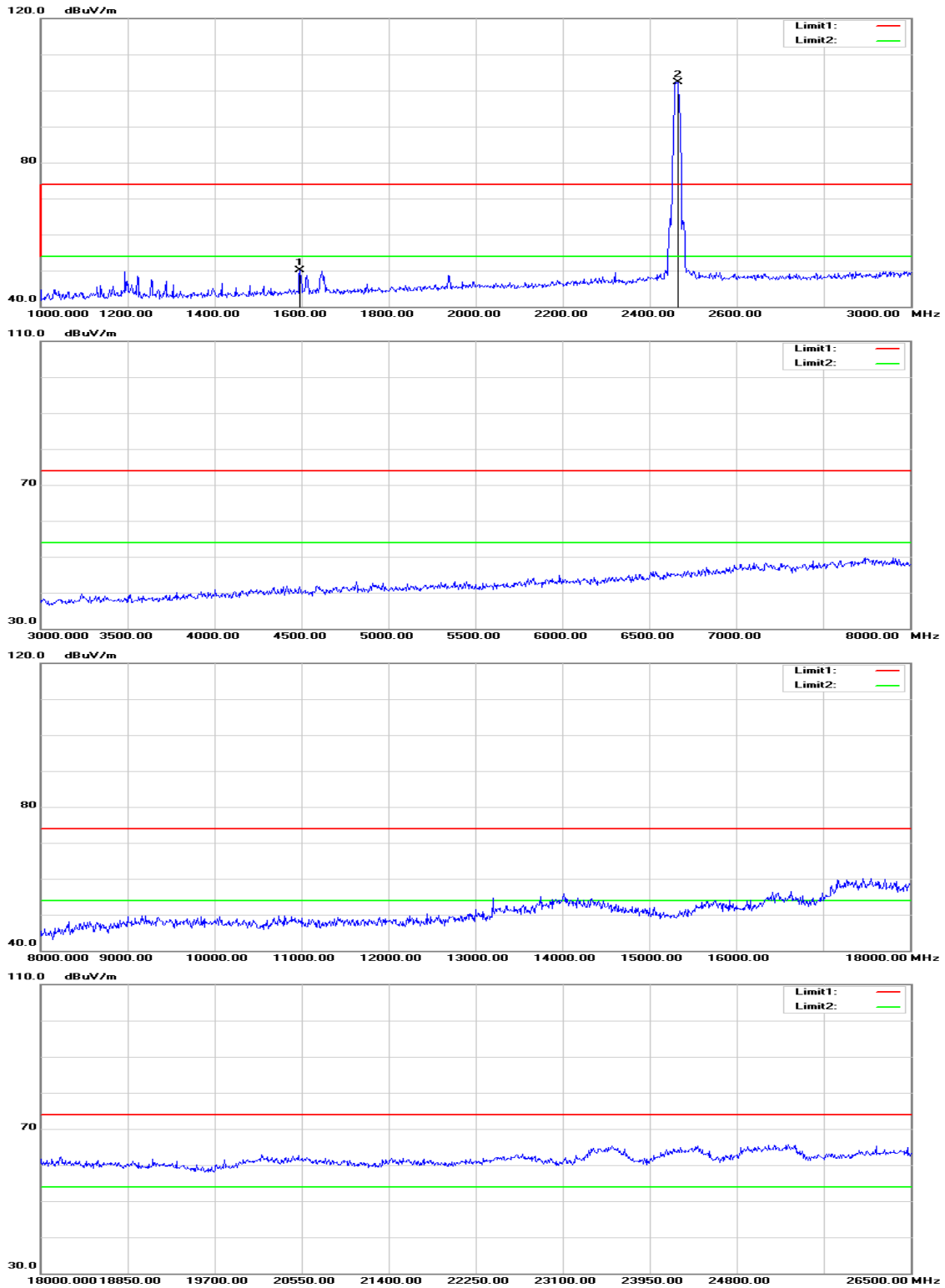

Operation Mode: TX / IEEE 802.11b / 2462 MHz

Test Date: November 11, 2015

Temperature: 27°C

Tested by: Jason Lu

Humidity: 53% RH

Polarity: Ver. / Hor.

Frequency (MHz)	Reading (dBuV)	Correction (dB/m)	Result (dBuV/m)	Limit (dBuV/m)	Margin (dB)	Remark	Ant.Pol. (H/V)
1940.000	50.53	-3.91	46.62	74.00	-27.38	peak	V
4925.000	48.65	5.37	54.02	74.00	-19.98	peak	V
4925.000	43.71	5.37	49.08	54.00	-4.92	AVG	V
7385.000	38.64	13.16	51.80	74.00	-22.20	peak	V
N/A							
1596.000	55.71	-5.69	50.02	74.00	-23.98	peak	H
N/A							

Remark:

1. Measuring frequencies from 1 GHz to the 10th harmonic of highest fundamental frequency.
2. Radiated emissions measured in frequency above 1000MHz were made with an instrument using peak/average detector mode.
3. Average test would be performed if the peak result were greater than the average limit or as required by the applicant.
4. Data of measurement within this frequency range shown " --- " in the table above means the reading of emissions are attenuated more than 20dB below the permissible limits or the field strength is too small to be measured.
5. Measurements above show only up to 6 maximum emissions noted, or would be lesser, with " N/A " remark, if no specific emissions from the EUT are recorded (ie: margin>20dB from the applicable limit) and considered that's already beyond the background noise floor.
6. Margin (dB) = Result (dBuV/m) – limit (dBuV/m).

TX / IEEE 802.11g / 2412 MHz

Polarity: Vertical

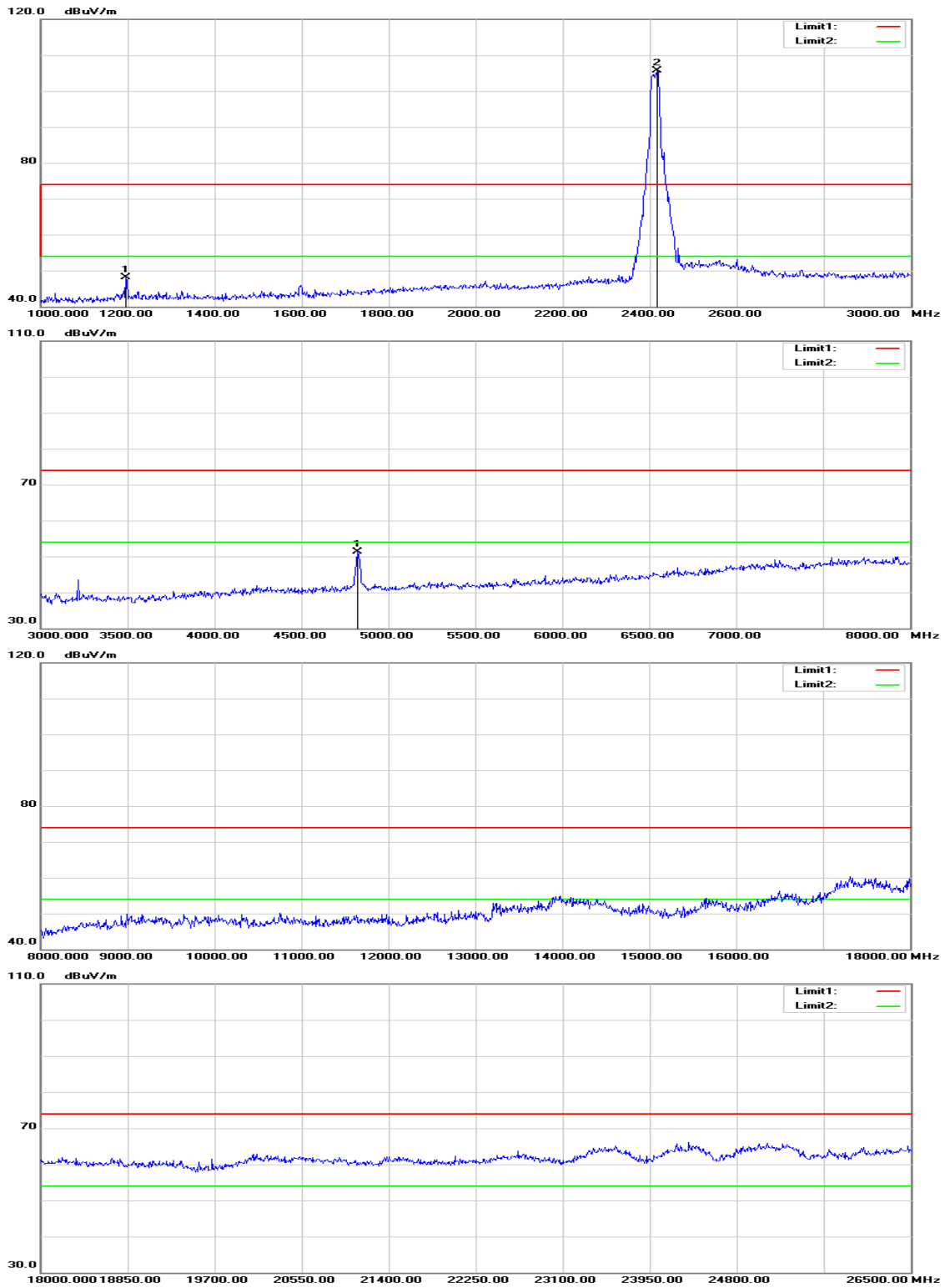

Polarity: Horizontal

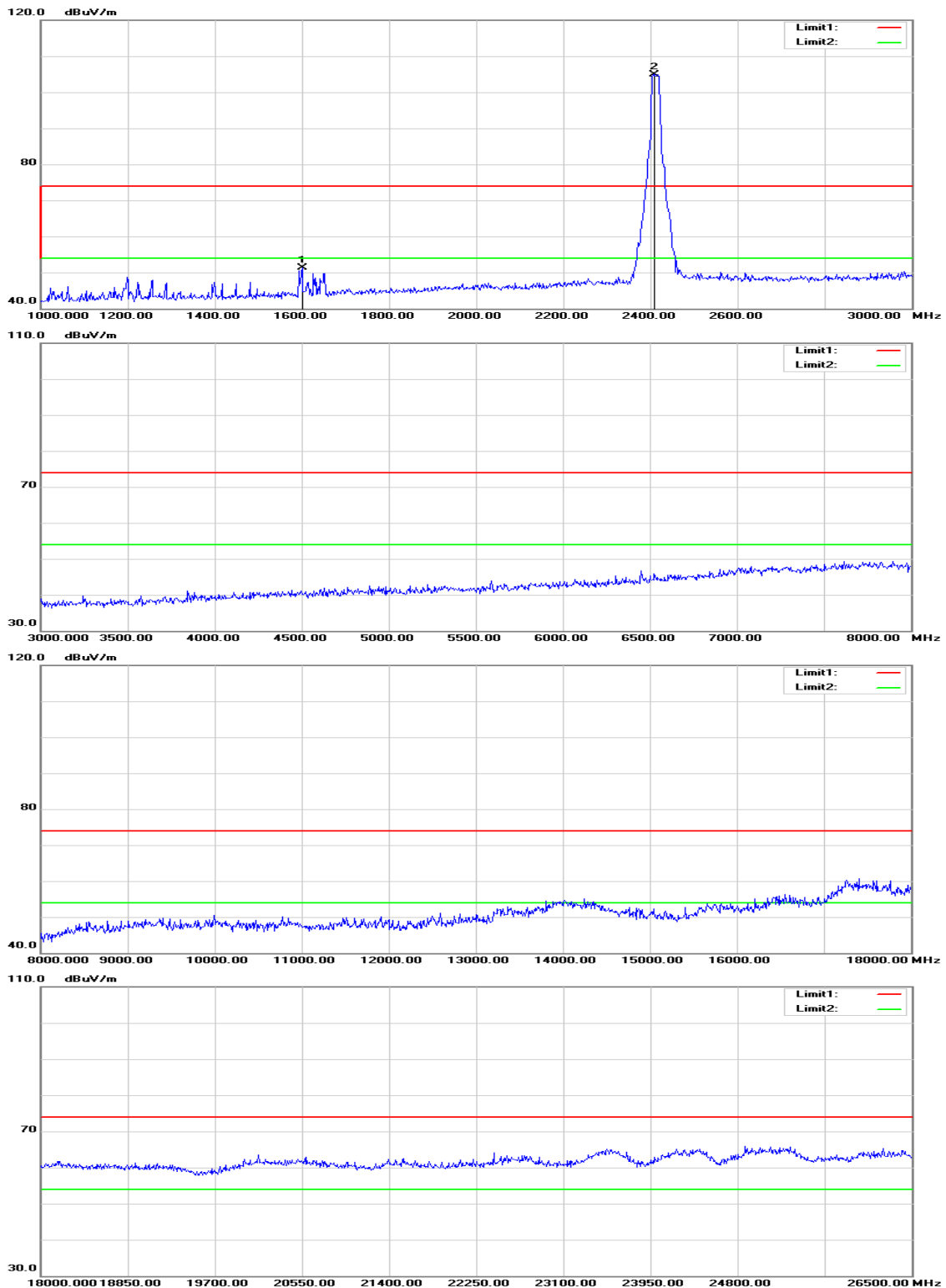

Operation Mode: TX / IEEE 802.11g / 2412 MHz

Test Date: November 11, 2015

Temperature: 27°C

Tested by: Jason Lu

Humidity: 53% RH

Polarity: Ver. / Hor.

Frequency (MHz)	Reading (dBuV)	Correction (dB/m)	Result (dBuV/m)	Limit (dBuV/m)	Margin (dB)	Remark	Ant.Pol. (H/V)
1196.000	55.28	-7.25	48.03	74.00	-25.97	peak	V
4820.000	46.15	5.09	51.24	74.00	-22.76	peak	V
N/A							
1600.000	56.94	-5.67	51.27	74.00	-22.73	peak	H
N/A							

Remark:

1. Measuring frequencies from 1 GHz to the 10th harmonic of highest fundamental frequency.
2. Radiated emissions measured in frequency above 1000MHz were made with an instrument using peak/average detector mode.
3. Average test would be performed if the peak result were greater than the average limit or as required by the applicant.
4. Data of measurement within this frequency range shown " --- " in the table above means the reading of emissions are attenuated more than 20dB below the permissible limits or the field strength is too small to be measured.
5. Measurements above show only up to 6 maximum emissions noted, or would be lesser, with " N/A " remark, if no specific emissions from the EUT are recorded (ie: margin>20dB from the applicable limit) and considered that's already beyond the background noise floor.
6. Margin (dB) = Result (dBuV/m) – limit (dBuV/m).

TX / IEEE 802.11g / 2437 MHz

Polarity: Vertical

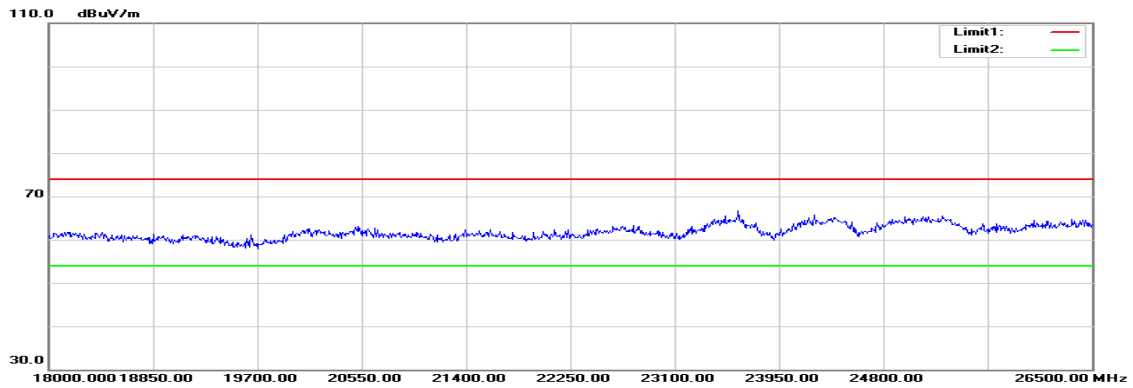
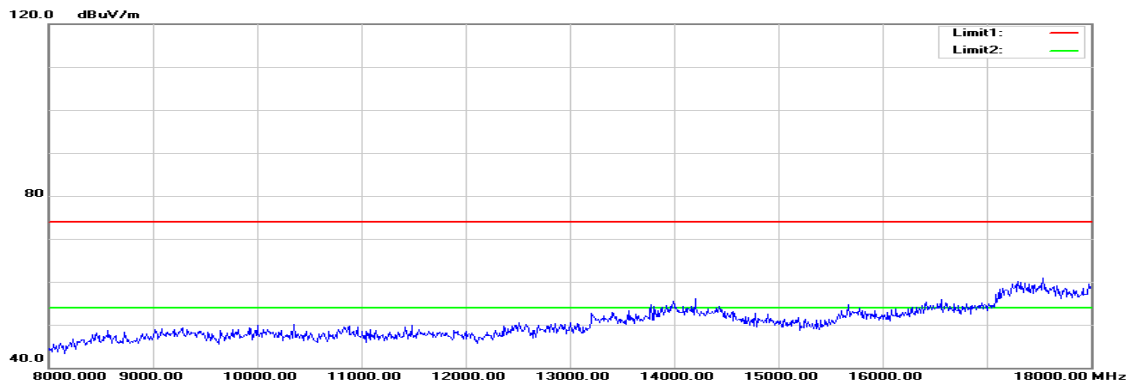
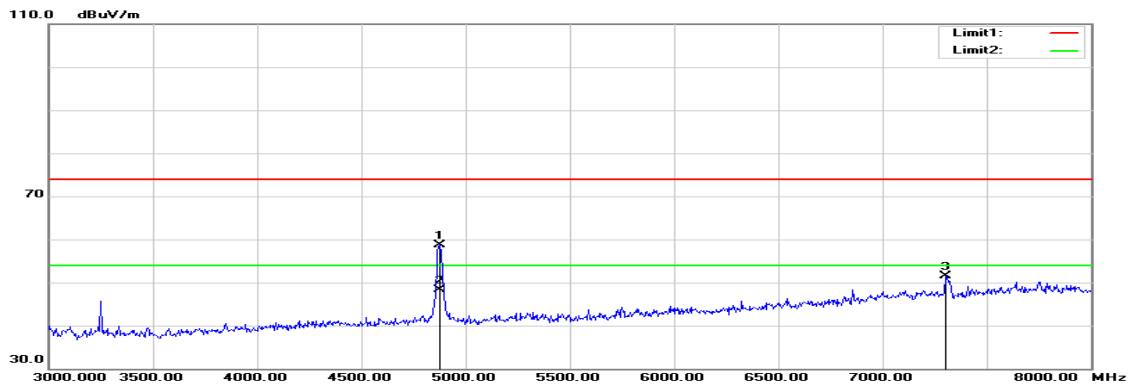
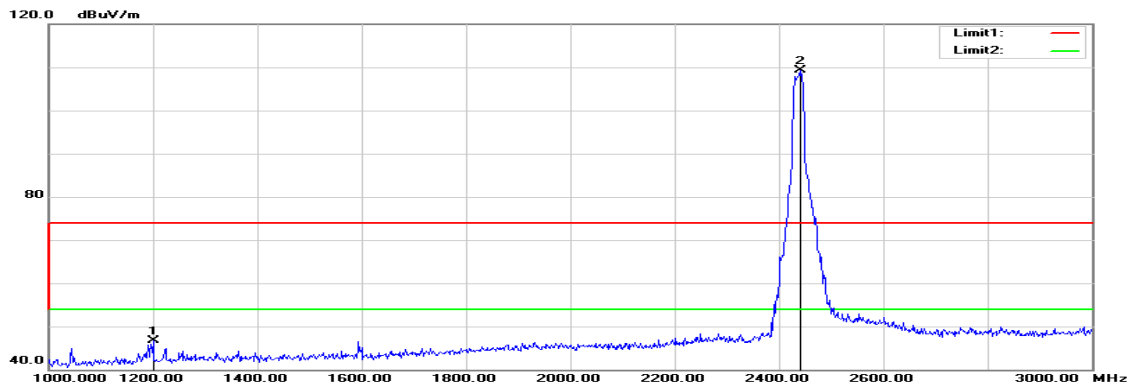

Polarity: Horizontal

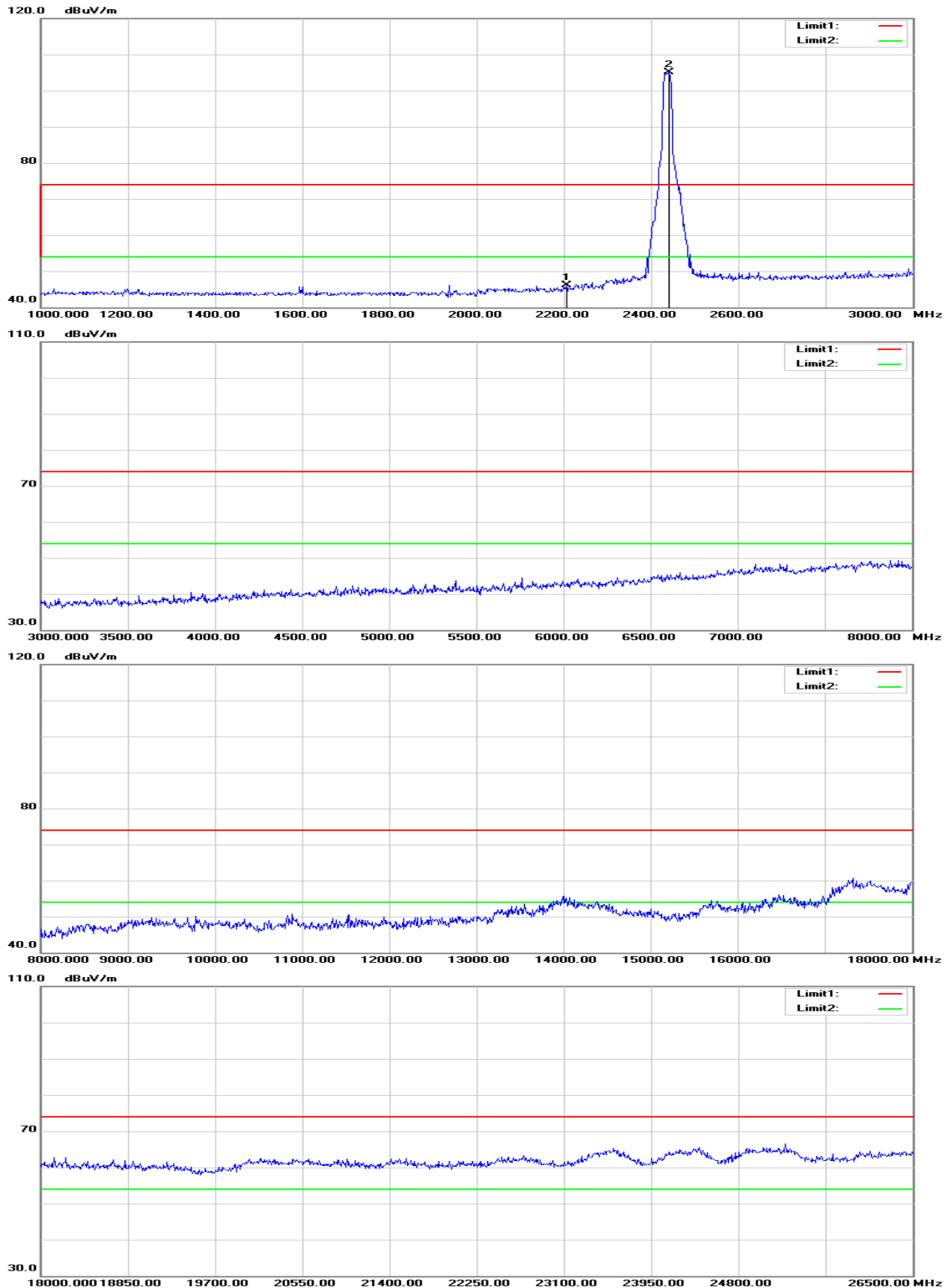

Operation Mode: TX / IEEE 802.11g / 2437 MHz

Test Date: November 11, 2015

Temperature: 27°C

Tested by: Jason Lu

Humidity: 53% RH

Polarity: Ver. / Hor.

Frequency (MHz)	Reading (dBuV)	Correction (dB/m)	Result (dBuV/m)	Limit (dBuV/m)	Margin (dB)	Remark	Ant.Pol. (H/V)
1200.000	53.88	-7.24	46.64	74.00	-27.36	peak	V
4875.000	53.46	5.24	58.70	74.00	-15.30	peak	V
4875.000	43.11	5.24	48.35	54.00	-5.65	AVG	V
7300.000	38.67	12.91	51.58	74.00	-22.42	peak	V
N/A							
2206.000	49.25	-3.14	46.11	74.00	-27.89	peak	H
N/A							

Remark:

1. Measuring frequencies from 1 GHz to the 10th harmonic of highest fundamental frequency.
2. Radiated emissions measured in frequency above 1000MHz were made with an instrument using peak/average detector mode.
3. Average test would be performed if the peak result were greater than the average limit or as required by the applicant.
4. Data of measurement within this frequency range shown " --- " in the table above means the reading of emissions are attenuated more than 20dB below the permissible limits or the field strength is too small to be measured.
5. Measurements above show only up to 6 maximum emissions noted, or would be lesser, with " N/A " remark, if no specific emissions from the EUT are recorded (ie: margin>20dB from the applicable limit) and considered that's already beyond the background noise floor.
6. Margin (dB) = Result (dBuV/m) – limit (dBuV/m).

TX / IEEE 802.11g / 2462 MHz

Polarity: Vertical

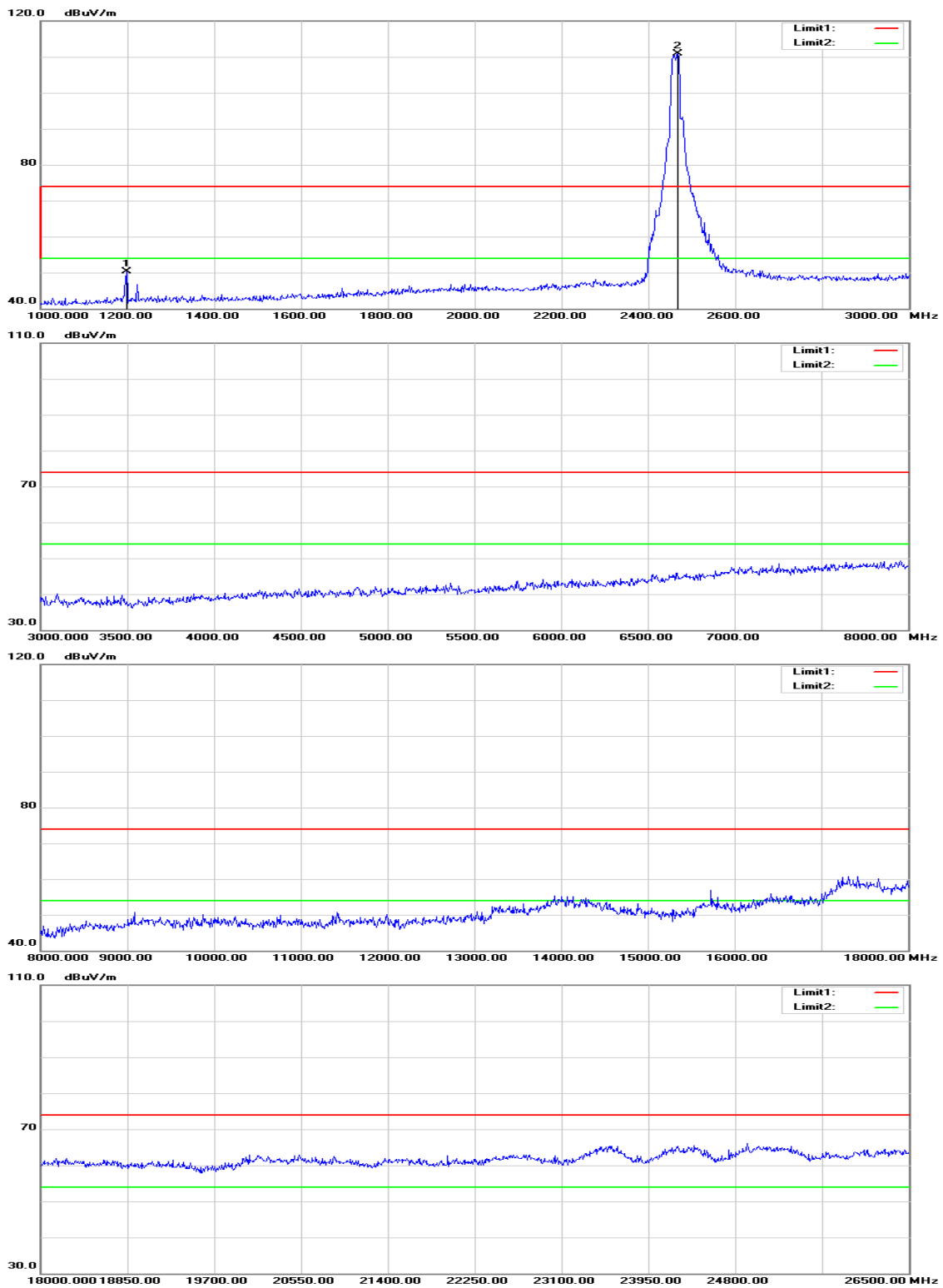

Polarity: Horizontal

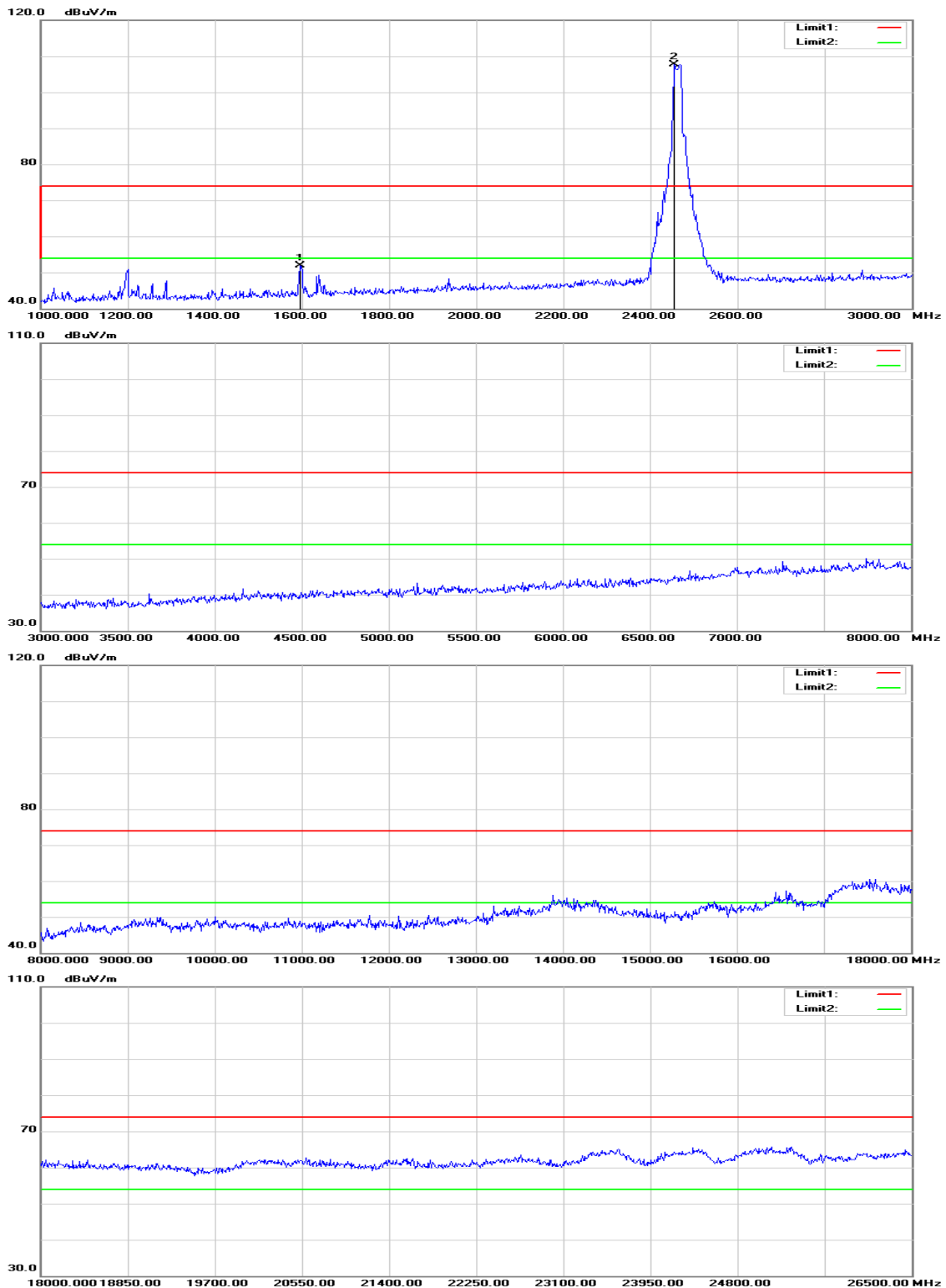

Operation Mode: TX / IEEE 802.11g / 2462 MHz

Test Date: November 11, 2015

Temperature: 27°C

Tested by: Jason Lu

Humidity: 53% RH

Polarity: Ver. / Hor.

Frequency (MHz)	Reading (dBuV)	Correction (dB/m)	Result (dBuV/m)	Limit (dBuV/m)	Margin (dB)	Remark	Ant.Pol. (H/V)
1198.000	57.60	-7.25	50.35	74.00	-23.65	peak	V
N/A							
1596.000	57.51	-5.69	51.82	74.00	-22.18	peak	H
N/A							

Remark:

1. Measuring frequencies from 1 GHz to the 10th harmonic of highest fundamental frequency.
2. Radiated emissions measured in frequency above 1000MHz were made with an instrument using peak/average detector mode.
3. Average test would be performed if the peak result were greater than the average limit or as required by the applicant.
4. Data of measurement within this frequency range shown “ --- ” in the table above means the reading of emissions are attenuated more than 20dB below the permissible limits or the field strength is too small to be measured.
5. Measurements above show only up to 6 maximum emissions noted, or would be lesser, with “ N/A ” remark, if no specific emissions from the EUT are recorded (ie: margin>20dB from the applicable limit) and considered that's already beyond the background noise floor.
6. Margin (dB) = Result (dBuV/m) – limit (dBuV/m).

TX / IEEE 802.11n HT 20 MHz / 2412 MHz

Polarity: Vertical

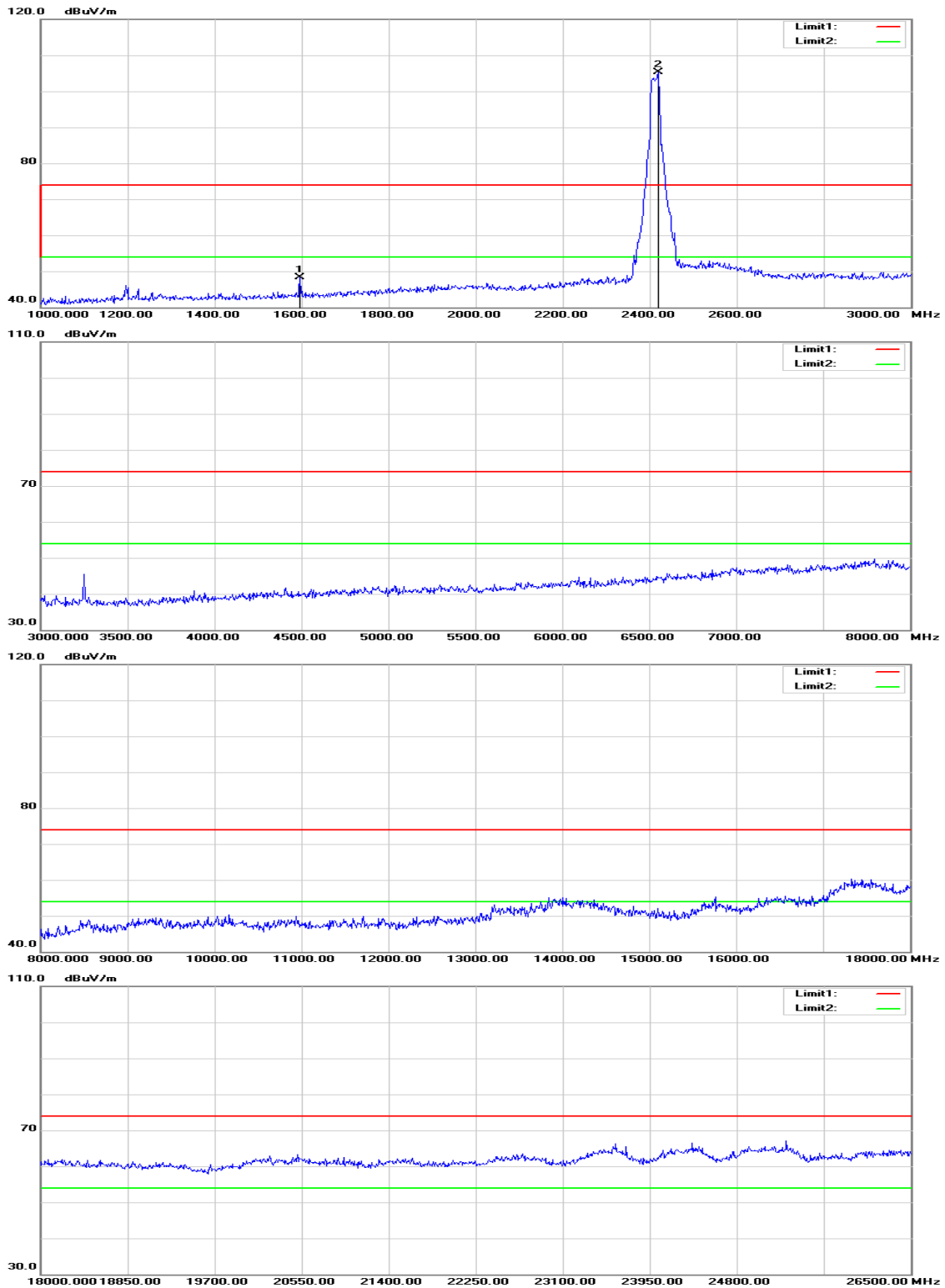

Polarity: Horizontal

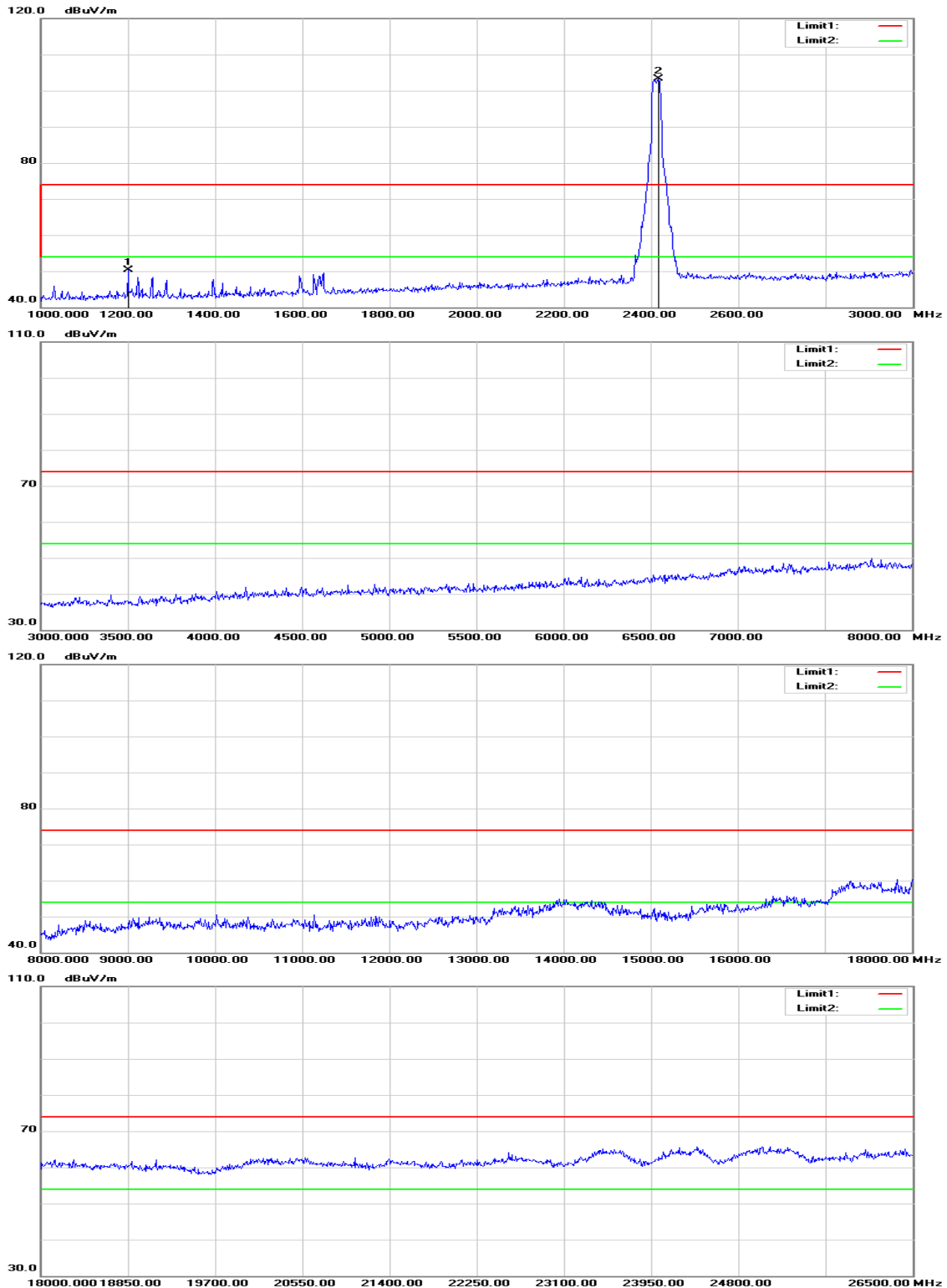

Operation Mode: TX / IEEE 802.11n HT 20 MHz / 2412 MHz **Test Date:** November 11, 2015
Temperature: 27°C **Tested by:** Jason Lu
Humidity: 53% RH **Polarity:** Ver. / Hor.

Frequency (MHz)	Reading (dBuV)	Correction (dB/m)	Result (dBuV/m)	Limit (dBuV/m)	Margin (dB)	Remark	Ant.Pol. (H/V)
1596.000	54.05	-5.69	48.36	74.00	-25.64	peak	V
N/A							
1200.000	57.48	-7.24	50.24	74.00	-23.76	peak	H
N/A							

Remark:

1. Measuring frequencies from 1 GHz to the 10th harmonic of highest fundamental frequency.
2. Radiated emissions measured in frequency above 1000MHz were made with an instrument using peak/average detector mode.
3. Average test would be performed if the peak result were greater than the average limit or as required by the applicant.
4. Data of measurement within this frequency range shown “ --- ” in the table above means the reading of emissions are attenuated more than 20dB below the permissible limits or the field strength is too small to be measured.
5. Measurements above show only up to 6 maximum emissions noted, or would be lesser, with “ N/A ” remark, if no specific emissions from the EUT are recorded (ie: margin>20dB from the applicable limit) and considered that's already beyond the background noise floor.
6. Margin (dB) = Result (dBuV/m) – limit (dBuV/m).

TX / IEEE 802.11n HT 20 MHz / 2437 MHz

Polarity: Vertical

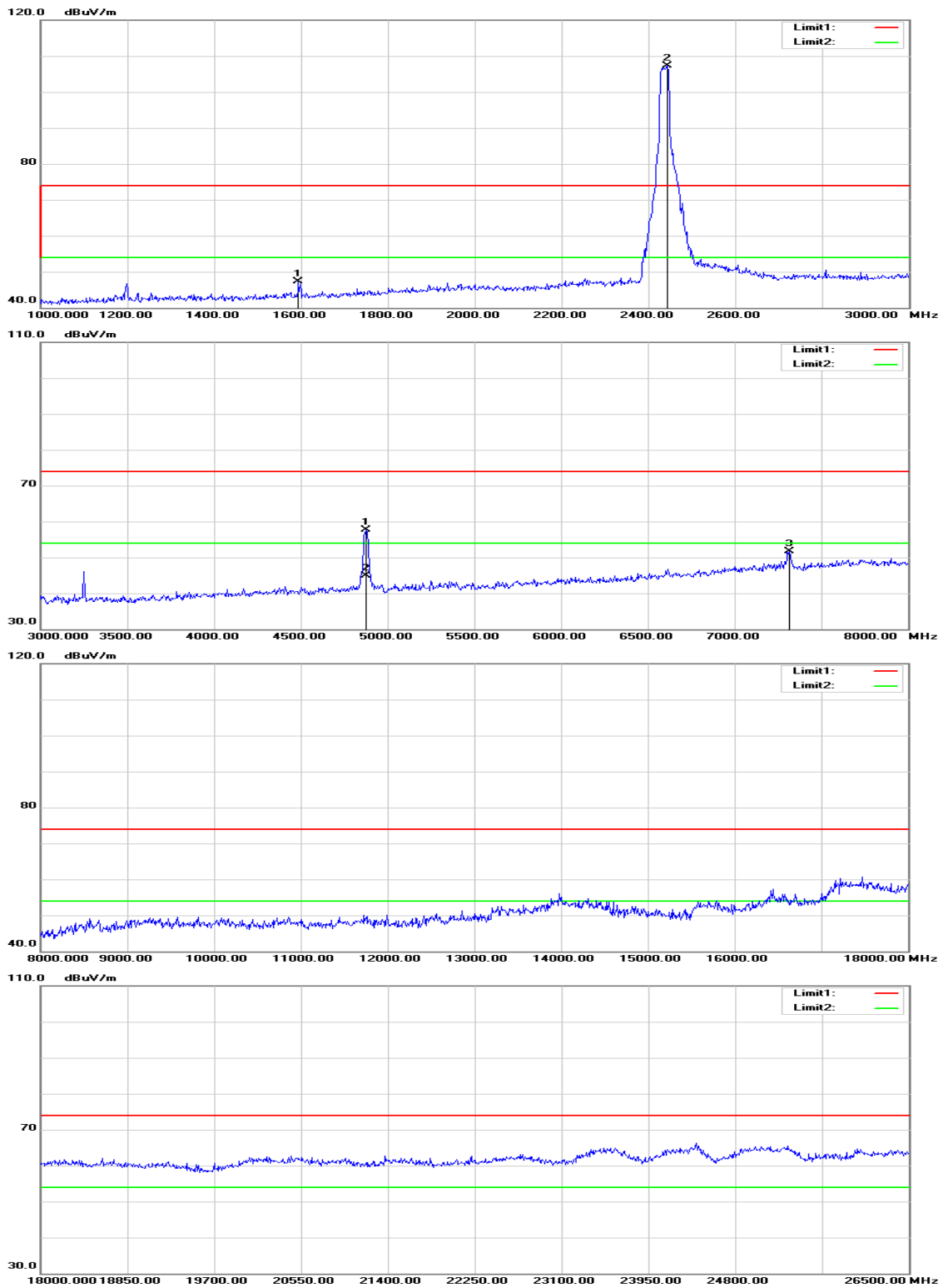

Polarity: Horizontal

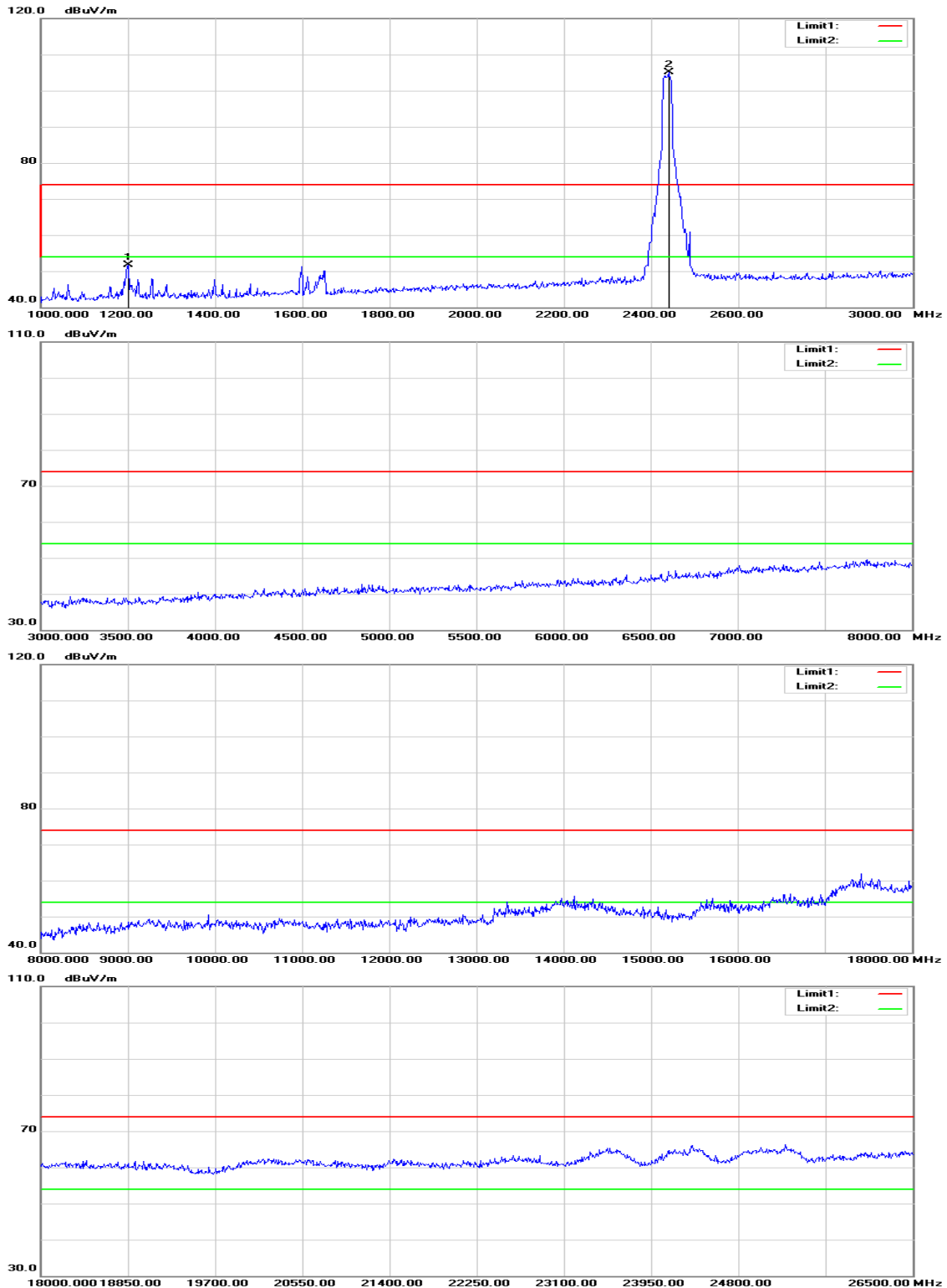

Operation Mode: TX / IEEE 802.11n HT 20 MHz / 2437 MHz **Test Date:** November 11, 2015
Temperature: 27°C **Tested by:** Jason Lu
Humidity: 53% RH **Polarity:** Ver. / Hor.

Frequency (MHz)	Reading (dBuV)	Correction (dB/m)	Result (dBuV/m)	Limit (dBuV/m)	Margin (dB)	Remark	Ant.Pol. (H/V)
1594.000	53.02	-5.70	47.32	74.00	-26.68	peak	V
4875.000	52.40	5.24	57.64	74.00	-16.36	peak	V
4875.000	39.70	5.24	44.94	54.00	-9.06	AVG	V
7315.000	38.84	12.95	51.79	74.00	-22.21	peak	V
N/A							
1200.000	58.91	-7.24	51.67	74.00	-22.33	peak	H
N/A							

Remark:

1. Measuring frequencies from 1 GHz to the 10th harmonic of highest fundamental frequency.
2. Radiated emissions measured in frequency above 1000MHz were made with an instrument using peak/average detector mode.
3. Average test would be performed if the peak result were greater than the average limit or as required by the applicant.
4. Data of measurement within this frequency range shown " --- " in the table above means the reading of emissions are attenuated more than 20dB below the permissible limits or the field strength is too small to be measured.
5. Measurements above show only up to 6 maximum emissions noted, or would be lesser, with " N/A " remark, if no specific emissions from the EUT are recorded (ie: margin>20dB from the applicable limit) and considered that's already beyond the background noise floor.
6. Margin (dB) = Result (dBuV/m) – limit (dBuV/m).

TX / IEEE 802.11n HT 20 MHz / 2462 MHz

Polarity: Vertical

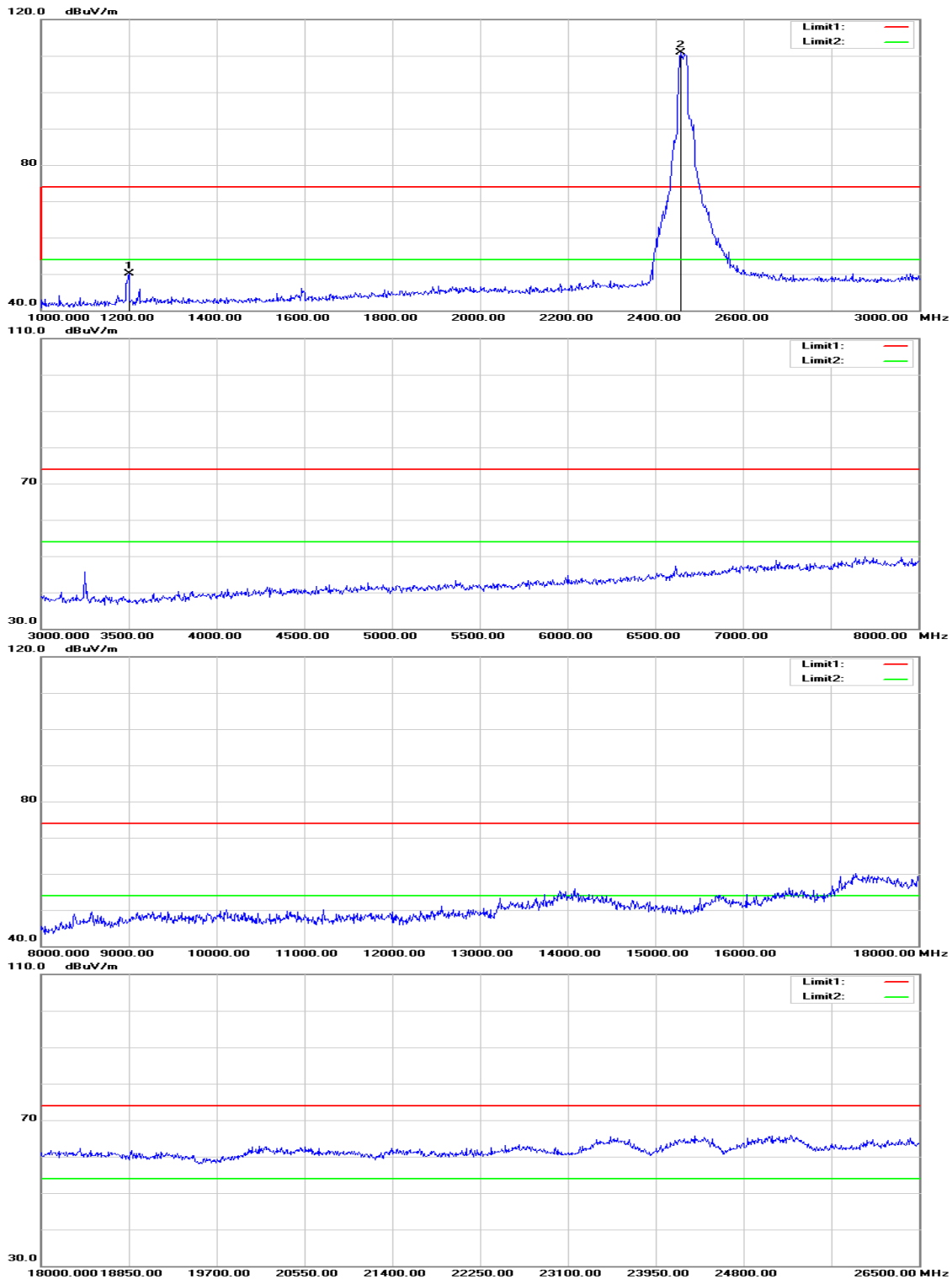

Polarity: Horizontal

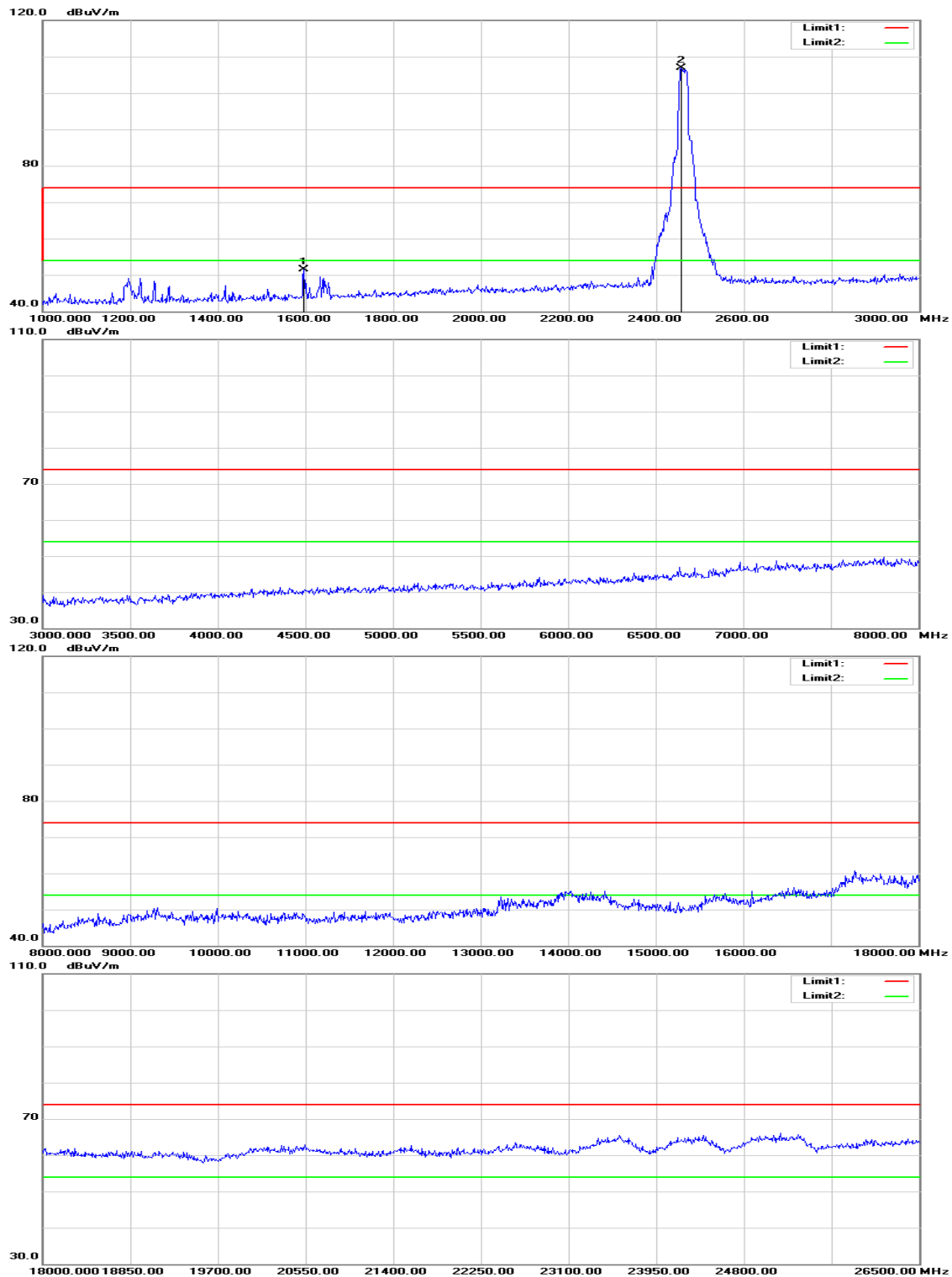

Operation Mode: TX / IEEE 802.11n HT 20 MHz / 2462 MHz **Test Date:** November 11, 2015
Temperature: 27°C **Tested by:** Jason Lu
Humidity: 53% RH **Polarity:** Ver. / Hor.

Frequency (MHz)	Reading (dBuV)	Correction (dB/m)	Result (dBuV/m)	Limit (dBuV/m)	Margin (dB)	Remark	Ant.Pol. (H/V)
1200.000	57.33	-7.24	50.09	74.00	-23.91	peak	V
N/A							
1596.000	57.16	-5.69	51.47	74.00	-22.53	peak	H
N/A							

Remark:

1. Measuring frequencies from 1 GHz to the 10th harmonic of highest fundamental frequency.
2. Radiated emissions measured in frequency above 1000MHz were made with an instrument using peak/average detector mode.
3. Average test would be performed if the peak result were greater than the average limit or as required by the applicant.
4. Data of measurement within this frequency range shown “ --- ” in the table above means the reading of emissions are attenuated more than 20dB below the permissible limits or the field strength is too small to be measured.
5. Measurements above show only up to 6 maximum emissions noted, or would be lesser, with “ N/A ” remark, if no specific emissions from the EUT are recorded (ie: margin>20dB from the applicable limit) and considered that's already beyond the background noise floor.
6. Margin (dB) = Result (dBuV/m) – limit (dBuV/m).

TX / IEEE 802.11n HT 40 MHz / 2422 MHz

Polarity: Vertical

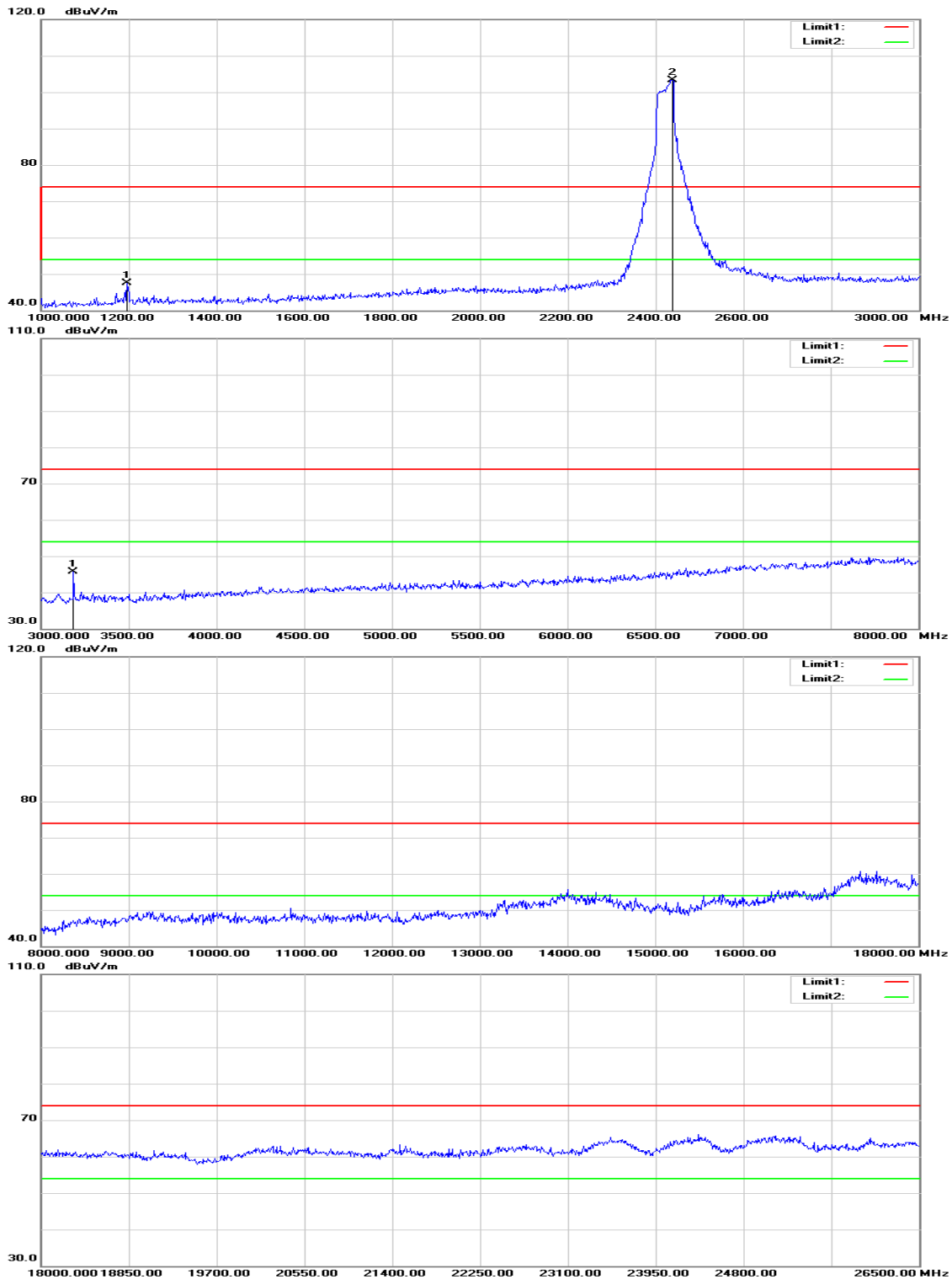

Polarity: Horizontal

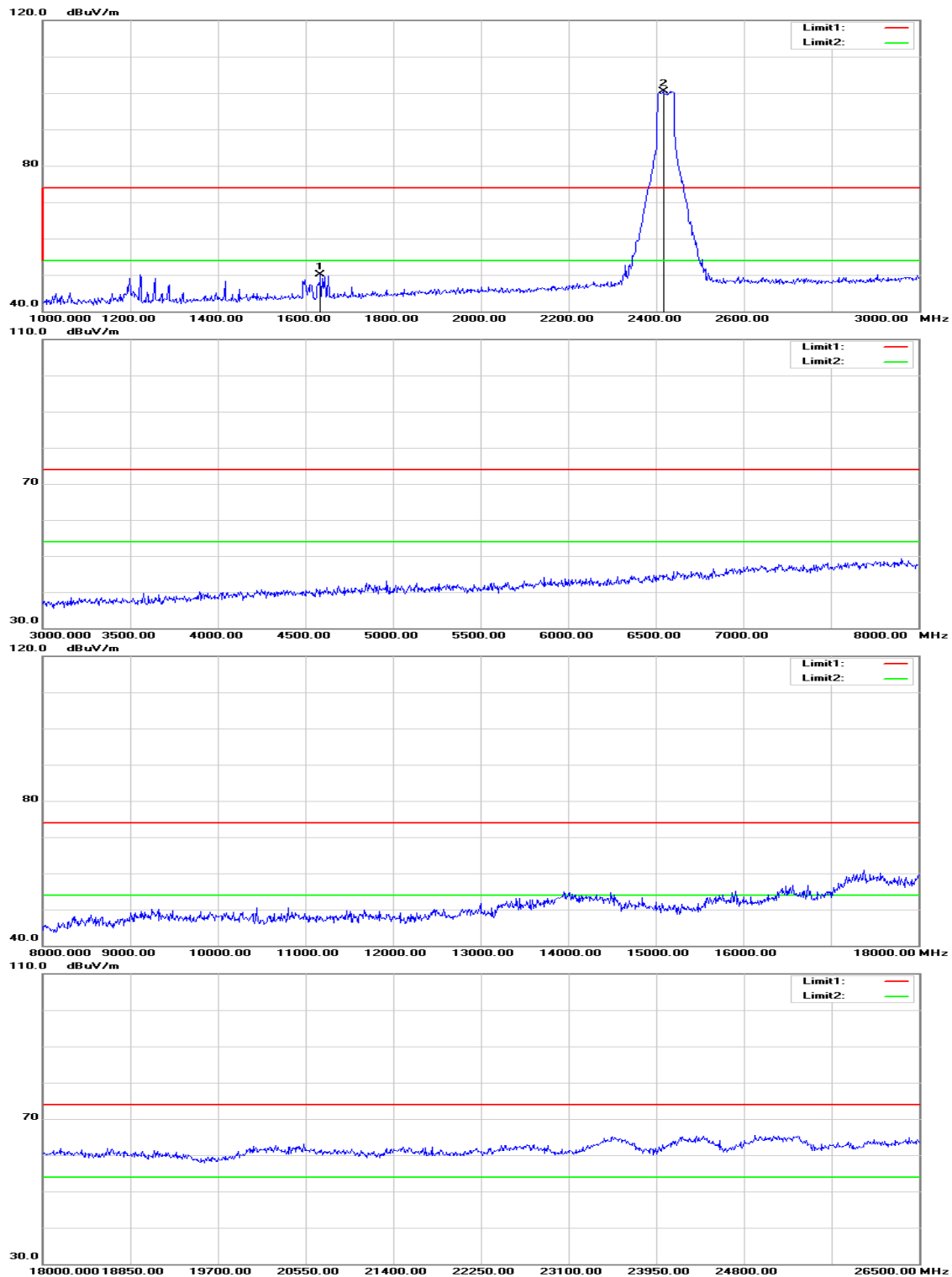

Operation Mode: TX / IEEE 802.11n HT 40 MHz / 2422 MHz **Test Date:** November 11, 2015
Temperature: 27°C **Tested by:** Jason Lu
Humidity: 53% RH **Polarity:** Ver. / Hor.

Frequency (MHz)	Reading (dBuV)	Correction (dB/m)	Result (dBuV/m)	Limit (dBuV/m)	Margin (dB)	Remark	Ant.Pol. (H/V)
1196.000	54.70	-7.25	47.45	74.00	-26.55	peak	V
3185.000	45.86	-0.16	45.70	74.00	-28.30	peak	V
N/A							
1634.000	55.65	-5.50	50.15	74.00	-23.85	peak	H
N/A							

Remark:

1. Measuring frequencies from 1 GHz to the 10th harmonic of highest fundamental frequency.
2. Radiated emissions measured in frequency above 1000MHz were made with an instrument using peak/average detector mode.
3. Average test would be performed if the peak result were greater than the average limit or as required by the applicant.
4. Data of measurement within this frequency range shown “ --- ” in the table above means the reading of emissions are attenuated more than 20dB below the permissible limits or the field strength is too small to be measured.
5. Measurements above show only up to 6 maximum emissions noted, or would be lesser, with “ N/A ” remark, if no specific emissions from the EUT are recorded (ie: margin>20dB from the applicable limit) and considered that's already beyond the background noise floor.
6. Margin (dB) = Result (dBuV/m) – limit (dBuV/m).

TX / IEEE 802.11n HT 40 MHz / 2437 MHz

Polarity: Vertical

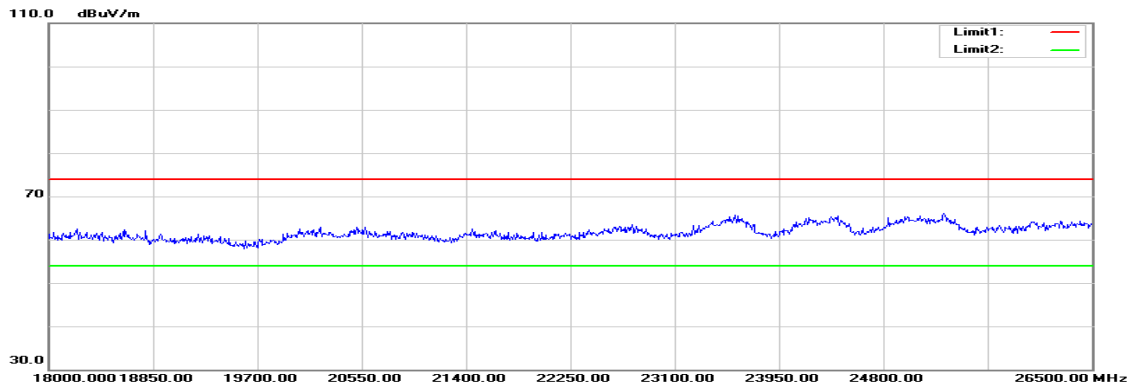
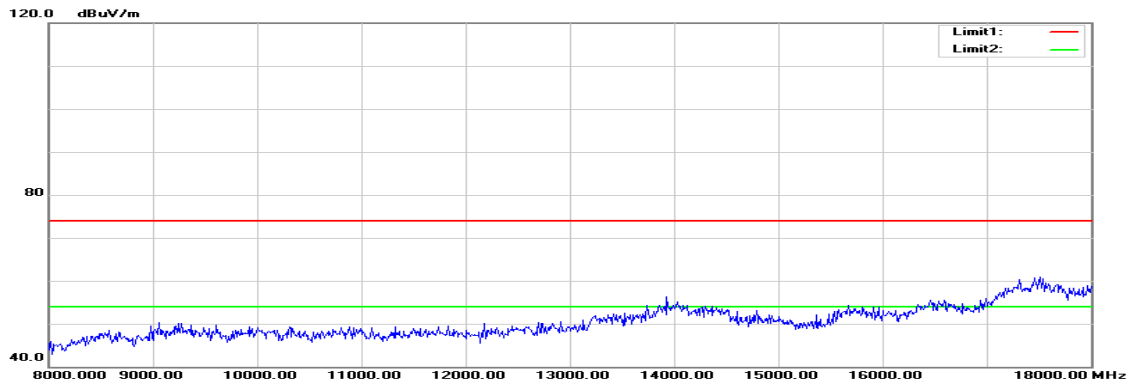
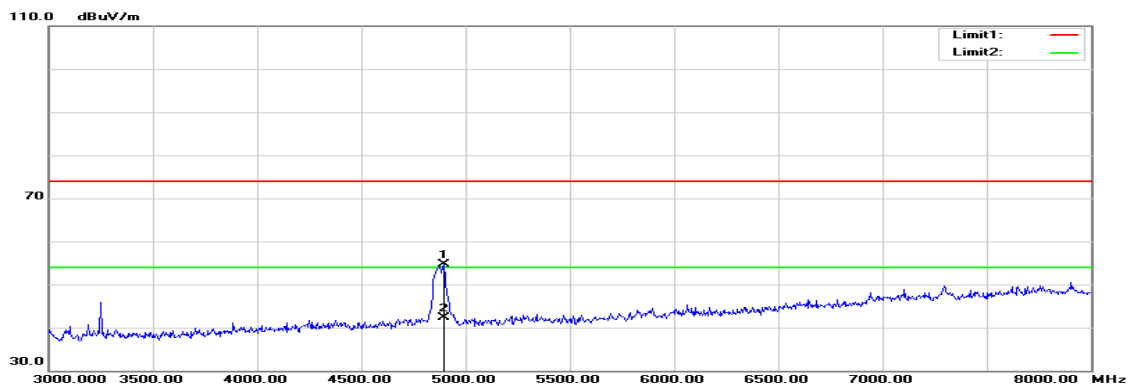
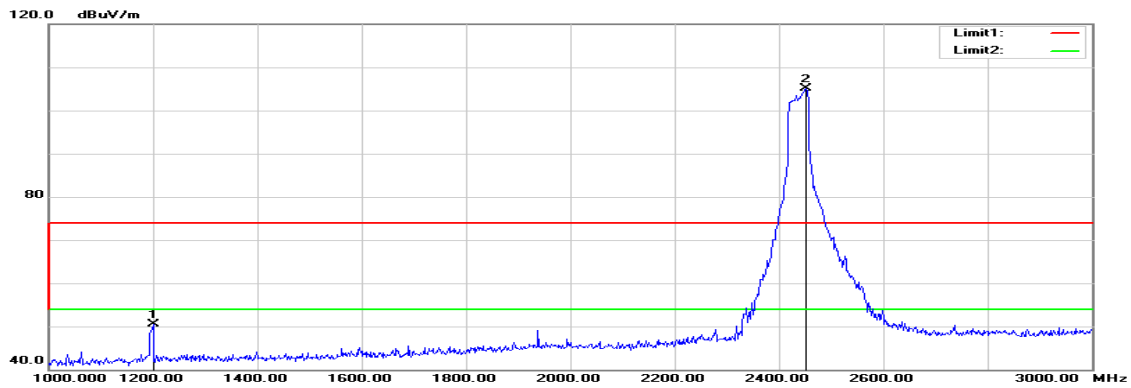

Polarity: Horizontal

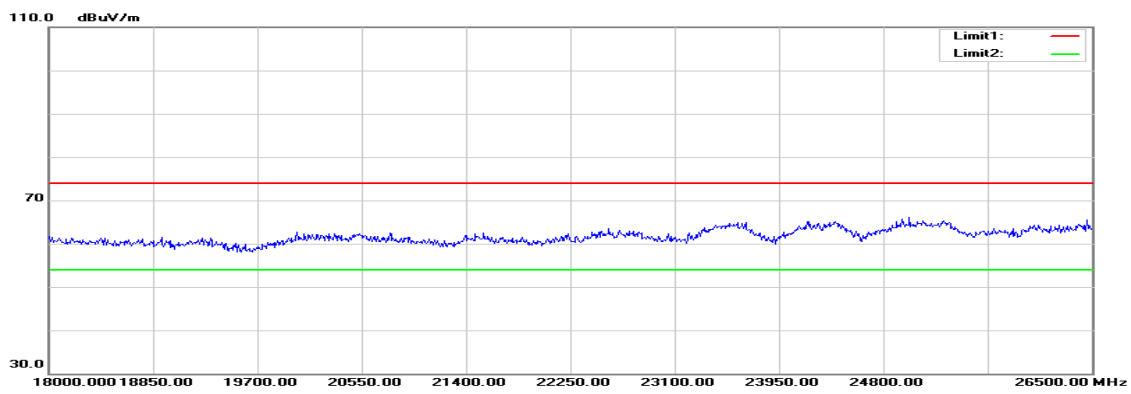
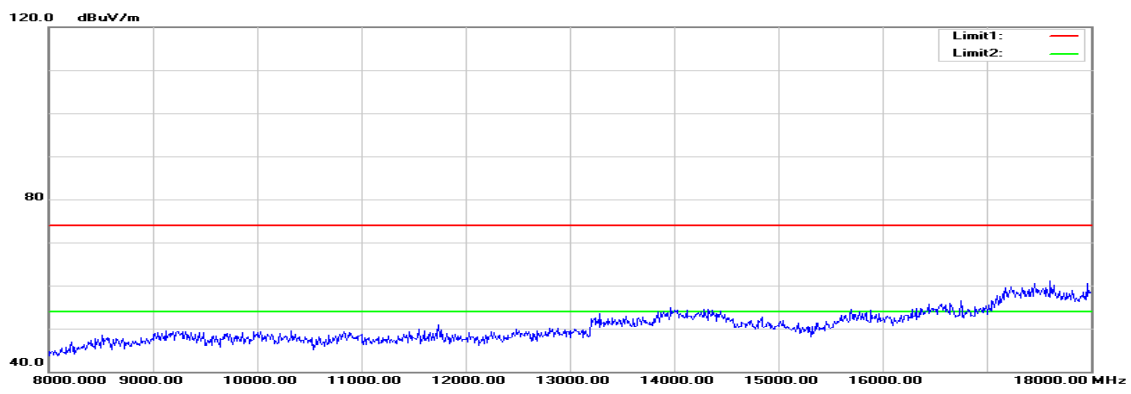
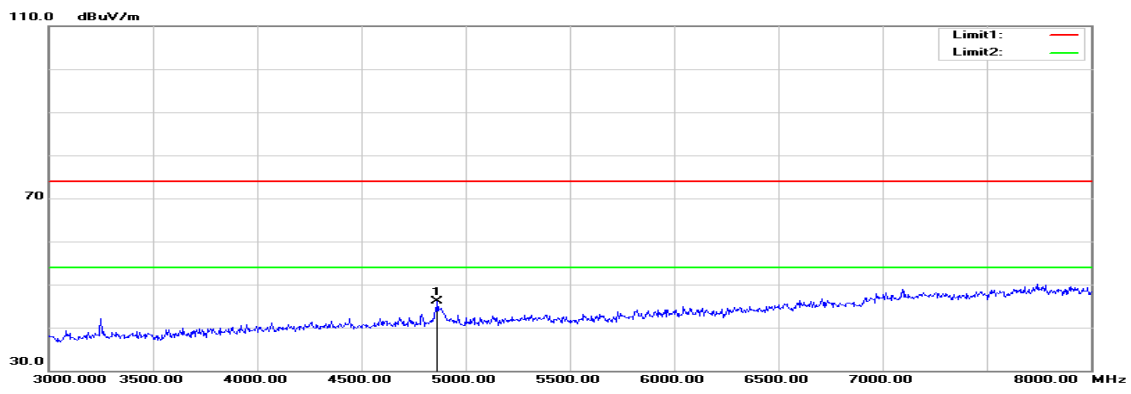
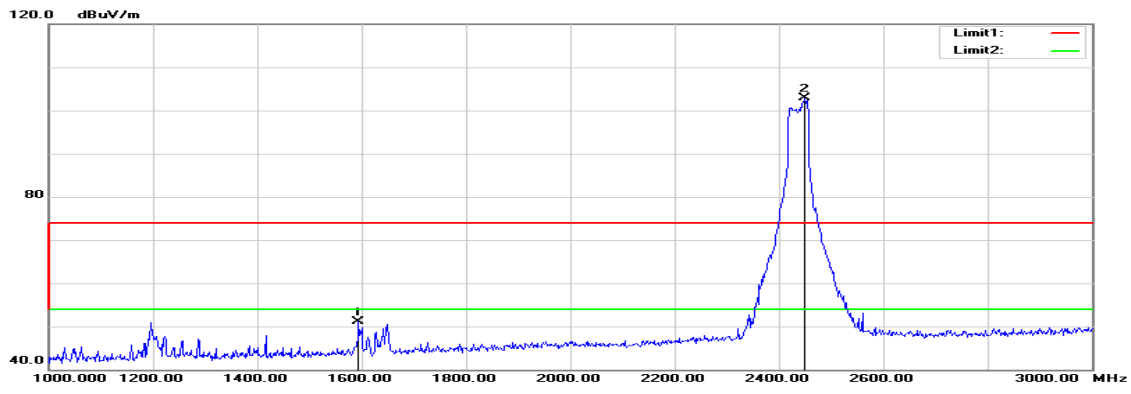

Operation Mode: TX / IEEE 802.11n HT 40 MHz / 2437 MHz **Test Date:** November 11, 2015
Temperature: 27°C **Tested by:** Jason Lu
Humidity: 53% RH **Polarity:** Ver. / Hor.

Frequency (MHz)	Reading (dBuV)	Correction (dB/m)	Result (dBuV/m)	Limit (dBuV/m)	Margin (dB)	Remark	Ant.Pol. (H/V)
1200.000	57.71	-7.24	50.47	74.00	-23.53	peak	V
4895.000	49.33	5.29	54.62	74.00	-19.38	peak	V
4895.000	37.05	5.29	42.34	54.00	-11.66	AVG	V
N/A							
1594.000	56.81	-5.70	51.11	74.00	-22.89	peak	H
4865.000	40.86	5.21	46.07	74.00	-27.93	peak	H
N/A							

Remark:

1. Measuring frequencies from 1 GHz to the 10th harmonic of highest fundamental frequency.
2. Radiated emissions measured in frequency above 1000MHz were made with an instrument using peak/average detector mode.
3. Average test would be performed if the peak result were greater than the average limit or as required by the applicant.
4. Data of measurement within this frequency range shown “ --- ” in the table above means the reading of emissions are attenuated more than 20dB below the permissible limits or the field strength is too small to be measured.
5. Measurements above show only up to 6 maximum emissions noted, or would be lesser, with “ N/A ” remark, if no specific emissions from the EUT are recorded (ie: margin>20dB from the applicable limit) and considered that's already beyond the background noise floor.
6. Margin (dB) = Result (dBuV/m) – limit (dBuV/m).

TX / IEEE 802.11n HT 40 MHz / 2452 MHz

Polarity: Vertical

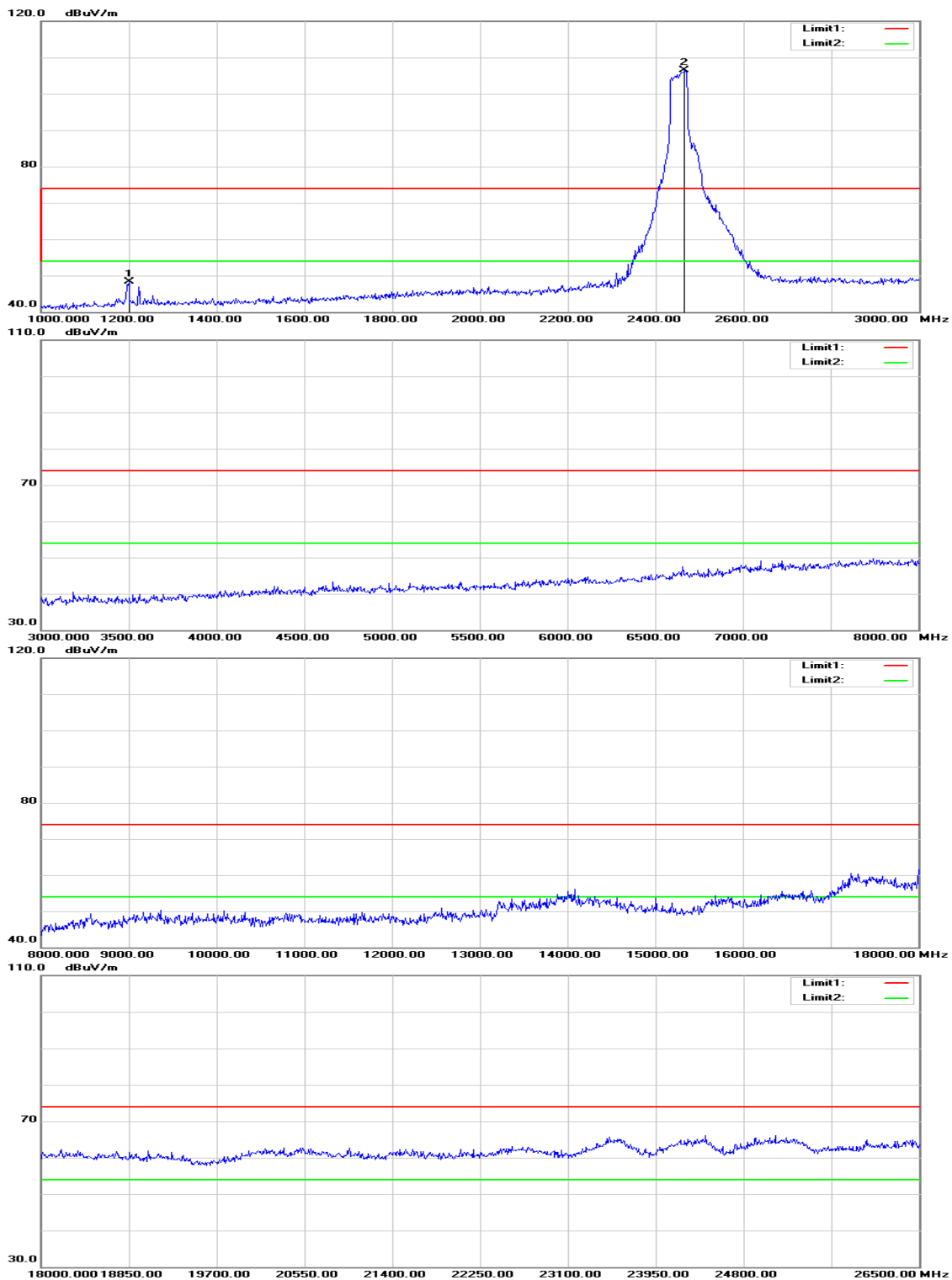

Polarity: Horizontal

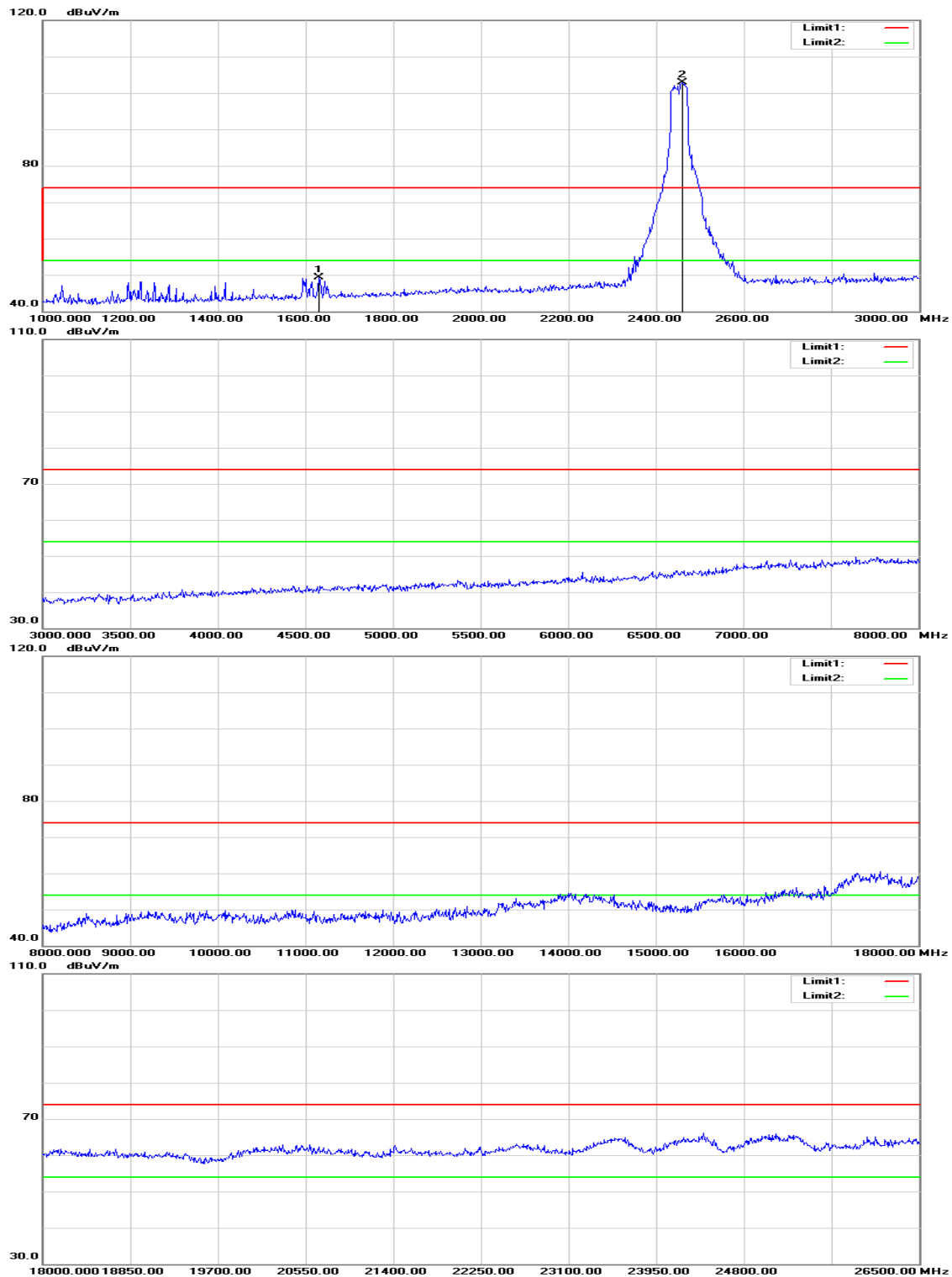

Operation Mode: TX / IEEE 802.11n HT 40 MHz / 2452 MHz **Test Date:** November 11, 2015
Temperature: 27°C **Tested by:** Jason Lu
Humidity: 53% RH **Polarity:** Ver. / Hor.

Frequency (MHz)	Reading (dBuV)	Correction (dB/m)	Result (dBuV/m)	Limit (dBuV/m)	Margin (dB)	Remark	Ant.Pol. (H/V)
1200.000	55.55	-7.24	48.31	74.00	-25.69	peak	V
N/A							
1630.000	54.91	-5.52	49.39	74.00	-24.61	peak	H
N/A							

Remark:

1. Measuring frequencies from 1 GHz to the 10th harmonic of highest fundamental frequency.
2. Radiated emissions measured in frequency above 1000MHz were made with an instrument using peak/average detector mode.
3. Average test would be performed if the peak result were greater than the average limit or as required by the applicant.
4. Data of measurement within this frequency range shown " --- " in the table above means the reading of emissions are attenuated more than 20dB below the permissible limits or the field strength is too small to be measured.
5. Measurements above show only up to 6 maximum emissions noted, or would be lesser, with " N/A " remark, if no specific emissions from the EUT are recorded (ie: margin>20dB from the applicable limit) and considered that's already beyond the background noise floor.
6. Margin (dB) = Result (dBuV/m) – limit (dBuV/m).

7.7 POWERLINE CONDUCTED EMISSIONS

LIMIT

According to §15.207(a), except as shown in paragraphs (b) and (c) of this section, for an intentional radiator that is designed to be connected to the public utility (AC) power line, the radio frequency voltage that is conducted back onto the AC power line on any frequency or frequencies within the band 150 kHz to 30 MHz shall not exceed the limits in the following table, as measured using a 50 μ H/50 ohms line impedance stabilization network (LISN). Compliance with the provisions of this paragraph shall be based on the measurement of the radio frequency voltage between each power line and ground at the power terminal. The lower limit applies at the boundary between the frequency ranges.

Frequency Range (MHz)	Limits (dB μ V)	
	Quasi-peak	Average
0.15 to 0.50	66 to 56*	56 to 46*
0.50 to 5	56	46
5 to 30	60	50

* Decreases with the logarithm of the frequency.

Test Configuration

See test photographs attached in Appendix 1 for the actual connections between EUT and support equipment.

TEST PROCEDURE

1. The EUT was placed on a table, which is 0.8m above ground plane.
2. Maximum procedure was performed on the six highest emissions to ensure EUT compliance.
3. Repeat above procedures until all frequency measured were complete.

TEST RESULTS

Not applicable, because EUT not connect to AC Main Source direct.