



**FCC 47 CFR PART 15 SUBPART C AND ANSI C63.10:2009
TEST REPORT**

For

Computer

Model : TREK-572 ; TREK-572XXXXXXXXXXXXXXXXXX
(where "X" may be any alphanumeric character , "-" or blank)

Trade Name : ADVANTECH

Issued for

Advantech Co. Ltd.

**No.1, Alley 20, Lane 26, Rueiguang Road, Neihu District, Taipei 114, Taiwan,
R.O.C.**

Issued by

**Compliance Certification Services Inc.
Hsinchu Lab.**

**NO. 989-1 Wen Shan Rd., Shang Shan Village,
Qionglin Shiang Hsinchu County 30741, Taiwan, R.O.C**

TEL: +886-3-5921698

FAX: +886-3-5921108

<http://www.ccsrf.com>

E-Mail : service@ccsrf.com

Issued Date: March 11, 2015



Note: This report shall not be reproduced except in full, without the written approval of Compliance Certification Services Inc. This document may be altered or revised by Compliance Certification Services Inc. personnel only, and shall be noted in the revision section of the document. The client should not use it to claim product endorsement by TAF or any government agencies. The test results of this report relate only to the tested sample identified in this report.



Revision History

Rev.	Issue Date	Revisions	Effect Page	Revised By
00	03/11/2015	Initial Issue	All Page 108	Dola Hsieh



TABLE OF CONTENTS

TITLE	PAGE NO.
1. TEST REPORT CERTIFICATION	4
2. EUT DESCRIPTION	5
3. DESCRIPTION OF TEST MODES	7
4. TEST METHODOLOGY	9
5. FACILITIES AND ACCREDITATION	9
5.1 FACILITIES	9
5.2 ACCREDITATIONS.....	9
5.3 MEASUREMENT UNCERTAINTY	10
6. SETUP OF EQUIPMENT UNDER TEST.....	11
7. FCC PART 15.247 REQUIREMENTS	13
7.1 6dB BANDWIDTH	13
7.2 MAXIMUM PEAK OUTPUT POWER	26
7.3 AVERAGE POWER	30
7.4 POWER SPECTRAL DENSITY	33
7.5 CONDUCTED SPURIOUS EMISSION	47
7.6 RADIATED EMISSION.....	63
7.7 CONDUCTED EMISSION.....	103
APPENDIX SETUP PHOTOS	106



1. TEST REPORT CERTIFICATION

Applicant : Advantech Co. Ltd.
Address : No.1, Alley 20, Lane 26, Rueiguang Road, Neihu District,
 Taipei 114, Taiwan, R.O.C.
Equipment Under Test : Computer
Model : TREK-572 ; TREK-572XXXXXXXXXXXXXXXXXX
 (where "X" may be any alphanumeric character , "-" or blank)
Trade Name : ADVANTECH
Tested Date : September 11 ~ December 02, 2014

APPLICABLE STANDARD	
Standard	Test Result
FCC Part 15 Subpart C AND ANSI C63.10:2009	PASS

WE HEREBY CERTIFY THAT: The above equipment has been tested by Compliance Certification Services Inc., and found compliance with the requirements set forth in the technical standards mentioned above. The results of testing in this report apply only to the product/system, which was tested. Other similar equipment will not necessarily produce the same results due to production tolerance and measurement uncertainties.

Approved by:

Reviewed by:

Sb. Lu
Sr. Engineer

Gundam Lin
Sr. Engineer



2. EUT DESCRIPTION

Product Name	Computer
Model Number	TREK-572 ; TREK-572XXXXXXXXXXXXXXXXXX (where "X" may be any alphanumeric character , "-" or blank)
Identify Number	T140911L12-A
Received Date	September 11, 2014
Frequency Range	IEEE 802.11b/g, 802.11gn HT20 : 2412MHz ~ 2462MHz IEEE 802.11gn HT40 : 2422MHz ~ 2452MHz Bluetooth 4.0 : 2402MHz ~ 2480MHz
Transmit Power	IEEE 802.11b : 23.94 dBm (0.2477 W) IEEE 802.11g : 26.38 dBm (0.4345 W) IEEE 802.11gn HT20 : 26.01 dBm (0.3990 W) IEEE 802.11gn HT40 : 24.67 dBm (0.2931 W) Bluetooth 4.0 : 2.63 dBm (0.0018W)
Channel Spacing	IEEE 802.11b/g, 802.11gn HT20/HT40 : 5MHz Bluetooth 4.0: 2MHz
Channel Number	IEEE 802.11b/g, 802.11gn HT20 : 11 Channels IEEE 802.11gn HT40 : 7 Channels Bluetooth 4.0 : 40 Channels
Transmit Data Rate	IEEE 802.11b : up to 11 Mbps IEEE 802.11g : up to 54 Mbps IEEE 802.11gn (HT20,800ns GI) : up to 65.00 Mbps IEEE 802.11gn (HT20,400ns GI) : up to 72.20 Mbps IEEE 802.11gn (HT40,800ns GI) : up to 135.00 Mbps IEEE 802.11gn (HT40,400ns GI) : up to 150.00 Mbps Bluetooth 4.0 : Additional GFSK
Type of Modulation	IEEE 802.11b : DSSS (CCK, DQPSK, DBPSK) IEEE 802.11g : OFDM (64QAM, 16QAM, QPSK, BPSK) IEEE 802.11gn HT20/40 : OFDM (64QAM, 16QAM, QPSK, BPSK) Bluetooth 4.0 : DSSS
Antenna Type	PIFA Antenna , Antenna Gain : 3.97 dBi
Power Rating	9-32Vdc
Test Voltage	120Vac, 60Hz
DC Power Cable Type	Non-shielded cable, 1.5m × 1 (Detachable)
I/O Port	EUT : RJ-45 Port × 1, USB Port × 1, Power Port × 1, VGA Port × 1, Signal Port × 1, Audio Port × 2 Panel : Signal Port × 1, USB Port × 1
Signal Cable	Shielded signal cable, 2m × 1 (Detachable), with two ferrite core



The difference of the series model

Model Number	Difference
TREK-572	1. For marketing purpose only. 2. where "X" may be any alphanumeric character , "-" or blank
TREK-572XXXXXXXXXXXXXXXXXXXX	

Remark :

1. The sample selected for test was engineering sample that approximated to production product and was provided by manufacturer.
2. For more details, please refer to the User's manual of the EUT.
3. The model TREK-572 was considered the main model for testing.
- 4 This submittal(s) (test report) is intended for FCC ID: M82-TREK572LTE filing to comply with Section 15.207, 15.209 and 15.247 of the FCC Part 15, Subpart C Rules.



3. DESCRIPTION OF TEST MODES

The EUT is an 802.11n transceiver in Computer form factor.
For IEEE 802.11b/g, 802.11gn HT20/HT40 mode : 1TX/1RX.

Conducted Emission / Radiated Emission Test (Below 1 GHz)

1. The following test modes were scanned during the preliminary test:

No.	Pre-Test Mode
1	TX Mode

2. After the preliminary scan, the following test mode was found to produce the highest emission level.

Final Test Mode		
Emission	Radiated Emission	TX Mode
	Conducted Emission	N/A

Remark : Then, the above highest emission mode of the configuration of the EUT and cable was chosen for all final test items.



Conducted / Radiated Emission Test (Above 1 GHz)

IEEE 802.11b, 802.11g, 802.11gn HT20 mode

The EUT had been tested under operating condition.

There are three channels have been tested as following :

Channel	Frequency (MHz)
Low	2412
Middle	2437
High	2462

IEEE 802.11b mode : 1Mbps data rate (worst case) were chosen for full testing.

IEEE 802.11g mode : 6Mbps data rate (worst case) were chosen for full testing.

IEEE 802.11gn HT20 mode : 6.5Mbps data rate (worst case) were chosen for full testing.

IEEE 802.11gn HT40 mode

The EUT had been tested under operating condition.

There are three channels have been tested as following :

Channel	Frequency (MHz)
Low	2422
Middle	2437
High	2452

IEEE 802.11gn HT40 mode : 13.5Mbps data rate (worst case) were chosen for full testing.

Bluetooth 4.0 mode

The EUT had been tested under operating condition.

There are three channels have been tested as following :

Channel	Frequency (MHz)
Low	2402
Middle	2440
High	2480

Remark : The field strength of spurious emission was measured in the following position: EUT stand-up position(X axis), lie-down position(X, Y axis). The worst emission was found in stand-up position(Z axis) and the worst case was recorded.



4. TEST METHODOLOGY

The tests documented in this report were performed in accordance with ANSI C63.10: 2009 and FCC CFR 47, 15.207, 15.209 and 15.247.

5. FACILITIES AND ACCREDITATION

5.1 FACILITIES

All measurement facilities used to collect the measurement data are located at

NO. 989-1 Wen Shan Rd., Shang Shan Village,
Qionglin Shiang Hsinchu County 30741, Taiwan, R.O.C

The sites are constructed in conformance with the requirements of ANSI C63.10:2009 and CISPR 22. All receiving equipment conforms to CISPR 16-1-1, CISPR 16-1-2, CISPR 16-1-3, CISPR 16-1-4, CISPR 16-1-5.

5.2 ACCREDITATIONS

Our laboratories are accredited and approved by the following approval agencies according to ISO/IEC 17025.

Taiwan	TAF
---------------	-----

The measuring facility of laboratories has been authorized or registered by the following approval agencies.

Canada	INDUSTRY CANADA
Japan	VCCI
Taiwan	BSMI
USA	FCC MRA

Copies of granted accreditation certificates are available for downloading from our web site, <http://www.ccsrf.com>

Remark: FCC Designation Number TW1027.



5.3 MEASUREMENT UNCERTAINTY

The following table is for the measurement uncertainty, which is calculated as per the document CISPR 16-4-2.

PARAMETER	UNCERTAINTY
Semi Anechoic Chamber (966 Chamber_B) / Radiated Emission, 30 to 1000 MHz	+/- 3.97
Semi Anechoic Chamber (966 Chamber_B) / Radiated Emission, 1 to 18GHz	+/- 3.58
Semi Anechoic Chamber (966 Chamber_B) / Radiated Emission, 18 to 26 GHz	+/- 3.59
Semi Anechoic Chamber (966 Chamber_B) / Radiated Emission, 26 to 40 GHz	+/- 3.81
Conducted Emission (Mains Terminals), 9kHz to 30MHz	+/- 2.48

This uncertainty represents an expanded uncertainty expressed at approximately the 95% confidence level using a coverage factor of $k=2$.

Consistent with industry standard (e.g. CISPR 22, clause 11, Measurement Uncertainty) determining compliance with the limits shall be base on the results of the compliance measurement. Consequently the measure emissions being less than the maximum allowed emission result in this be a compliant test or passing test.

The acceptable measurement uncertainty value without requiring revision of the compliance statement is base on conducted and radiated emissions being less than U_{CISPR} which is 3.6dB and 5.2dB respectively. CCS values (called U_{Lab} in CISPR 16-4-2) is less than U_{CISPR} as shown in the table above. Therefore, MU need not be considered for compliance.



6. SETUP OF EQUIPMENT UNDER TEST

SUPPORT EQUIPMENT

No.	Product	Manufacturer	Model No.	Serial No.
1	Notebook PC	HP	ProBook 4421s	CNF03242PJ
2	DC Power Supply	Rohde & Schwarz	NGSM 32/10	100232

No.	Signal Cable Description
1	Non-shielded RJ-45 cable, 12m × 1



SETUP DIAGRAM FOR TESTS

EUT & peripherals setup diagram is shown in appendix setup photos.

EUT OPERATING CONDITION

WiFi

1. EUT & peripherals setup diagram is shown in appendix setup photos.
2. Run Test software. “artqui”

(1) TX Mode:

- Tx Data Rate: 1Mbps Bandwidth 20 (IEEE 802.11b mode)
- 6Mbps Bandwidth 20 (IEEE 802.11g mode)
- 6.5Mbps Bandwidth 20 (IEEE 802.11gn HT20 mode)
- 13.5Mbps Bandwidth 40 (IEEE 802.11gn HT40 mode)

Power control

- IEEE 802.11b Channel Low (2412MHz) Power set 17.5
 - IEEE 802.11b Channel Mid (2442MHz) Power set 22
 - IEEE 802.11b Channel High (2472MHz) Power set 18
 - IEEE 802.11g Channel Low (2412MHz) Power set 14
 - IEEE 802.11g Channel Mid (2442MHz) Power set 21
 - IEEE 802.11g Channel High (2472MHz) Power set 15
 - IEEE 802.11gn HT20 Channel Low (2412MHz) Power set 13
 - IEEE 802.11gn HT20 Channel Mid (2442MHz) Power set 20
 - IEEE 802.11gn HT20 Channel High (2472MHz) Power set 14
 - IEEE 802.11gn HT40 Channel Low (2422MHz) Power set 11
 - IEEE 802.11gn HT40 Channel Mid (2442MHz) Power set 16
 - IEEE 802.11gn HT40 Channel High (2462MHz) Power set 12
3. All of the functions are under run.
 4. Start test.

Bluetooth 4.0

1. EUT & peripherals setup diagram is shown in appendix setup photos.
2. Run “BtUSBTool” Software to test
3. PACKET TRANSMIT (TX Mode)
 - Freq: 2402, 2440, 2480
 - Power Setting : Default
4. All of the functions are under run.
5. Start test



7. FCC PART 15.247 REQUIREMENTS

7.1 6dB BANDWIDTH

LIMITS

§ 15.247(a) (2) For direct sequence systems, the minimum 6dB bandwidth shall be at least 500kHz.

TEST EQUIPMENT

Name of Equipment	Manufacturer	Model	Serial Number	Calibration Due
Spectrum Analyzer	Agilent	E4446A	MY43360132	06/10/2015

Remark: Each piece of equipment is scheduled for calibration once a year.

TEST SETUP



TEST PROCEDURE

1. The transmitter output was connected to a spectrum analyzer.
2. Set RBW = 100 kHz.
3. Set the video bandwidth (VBW) $\geq 3 \times$ RBW.
4. Detector = Peak.
5. Trace mode = max hold.
6. Sweep = auto couple.
7. Allow the trace to stabilize.
8. Measure the maximum width of the emission that is constrained by the frequencies associated with the two outermost amplitude points (upper and lower frequencies) that are attenuated by 6 dB relative to the maximum level measured in the fundamental emission.



TEST RESULTS

IEEE 802.11b Mode

Channel	Channel Frequency (MHz)	6dB Bandwidth (MHz)	Minimum Limit (kHz)	Pass / Fail
Low	2412	10.04	500	PASS
Middle	2437	10.07	500	PASS
High	2462	10.06	500	PASS

IEEE 802.11g Mode

Channel	Channel Frequency (MHz)	6dB Bandwidth (MHz)	Minimum Limit (kHz)	Pass / Fail
Low	2412	16.35	500	PASS
Middle	2437	16.39	500	PASS
High	2462	16.36	500	PASS

IEEE 802.11gn HT20 Mode

Channel	Channel Frequency (MHz)	6dB Bandwidth (MHz)	Minimum Limit (kHz)	Pass / Fail
Low	2412	17.54	500	PASS
Middle	2437	17.31	500	PASS
High	2462	17.56	500	PASS

IEEE 802.11gn HT40 Mode

Channel	Channel Frequency (MHz)	6dB Bandwidth (MHz)	Minimum Limit (kHz)	Pass / Fail
Low	2422	36.38	500	PASS
Middle	2437	36.40	500	PASS
High	2452	36.33	500	PASS



Bluetooth 4.0 Mode

Channel	Channel Frequency (MHz)	6dB Bandwidth (kHz)	Minimum Limit (kHz)	Pass / Fail
Low	2402	664.2	500	PASS
Middle	2440	669.3	500	PASS
High	2480	669.3	500	PASS



6dB BANDWIDTH

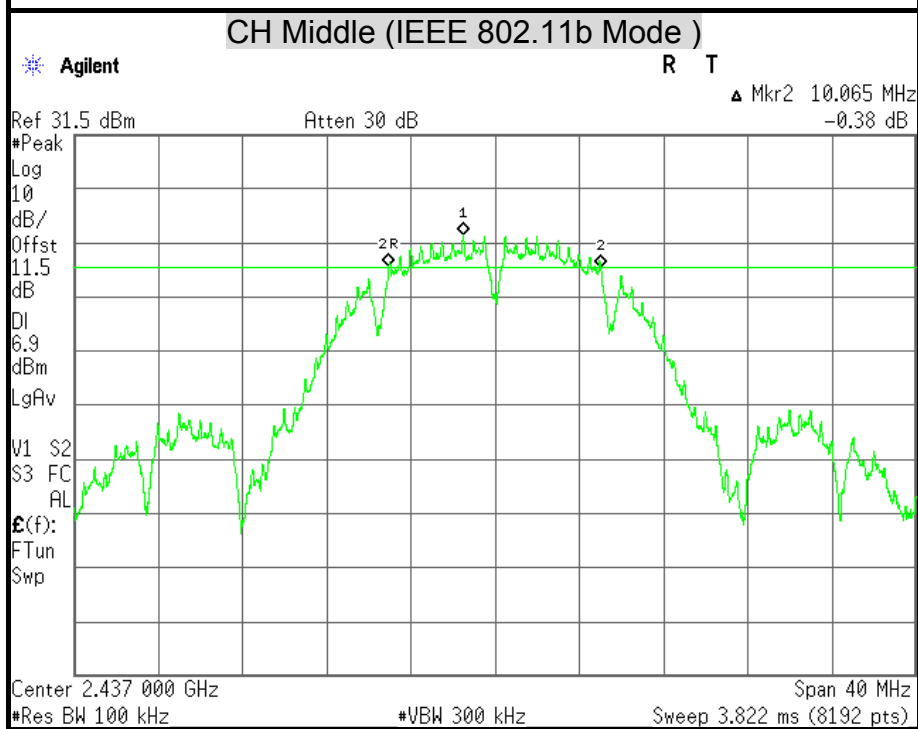
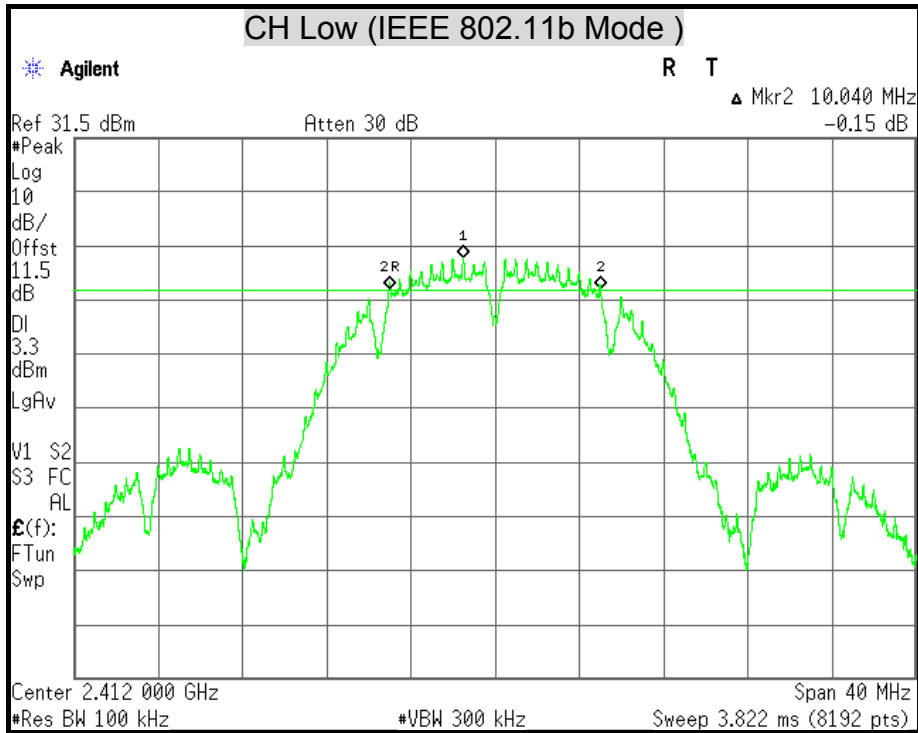

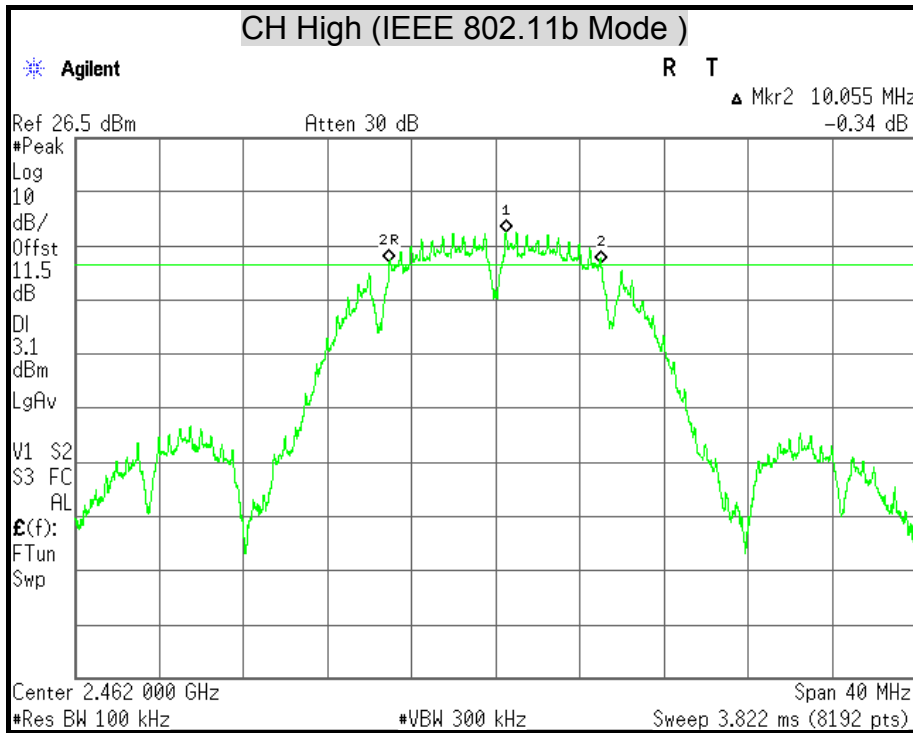

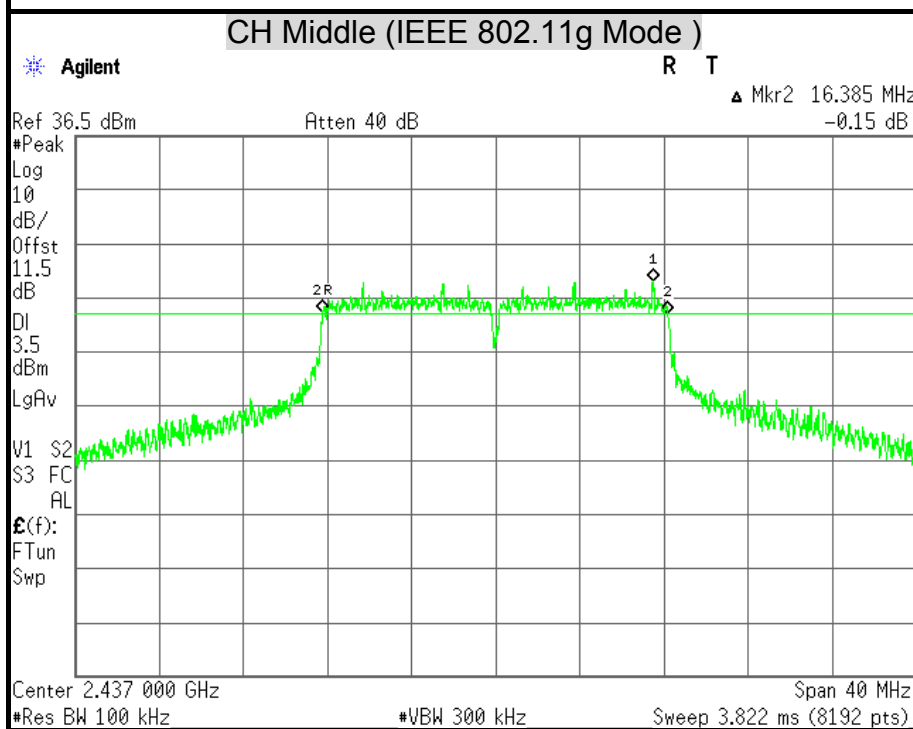
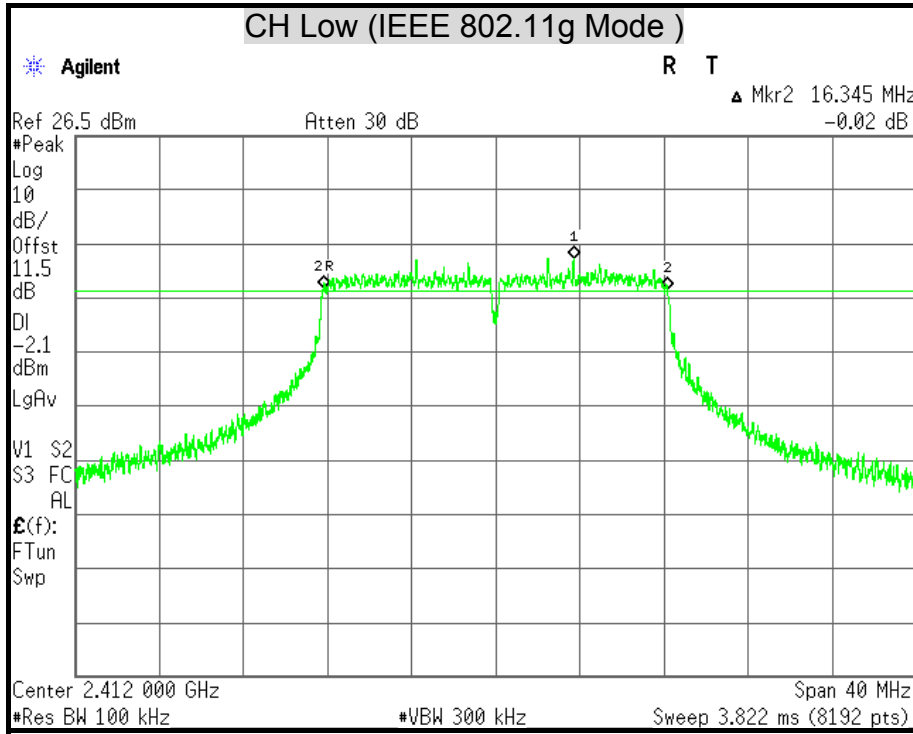

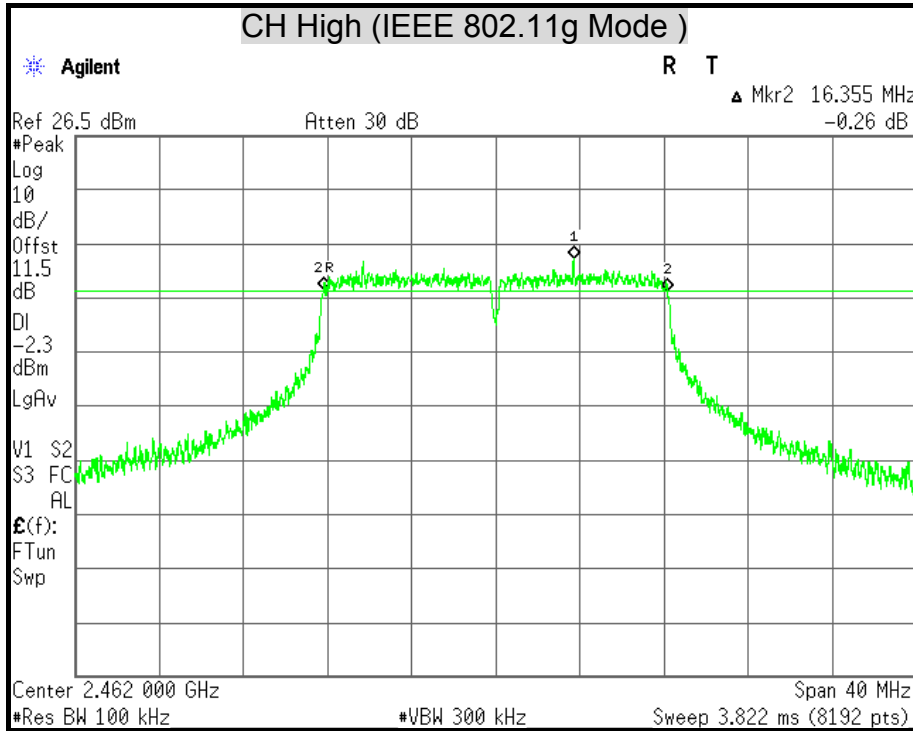

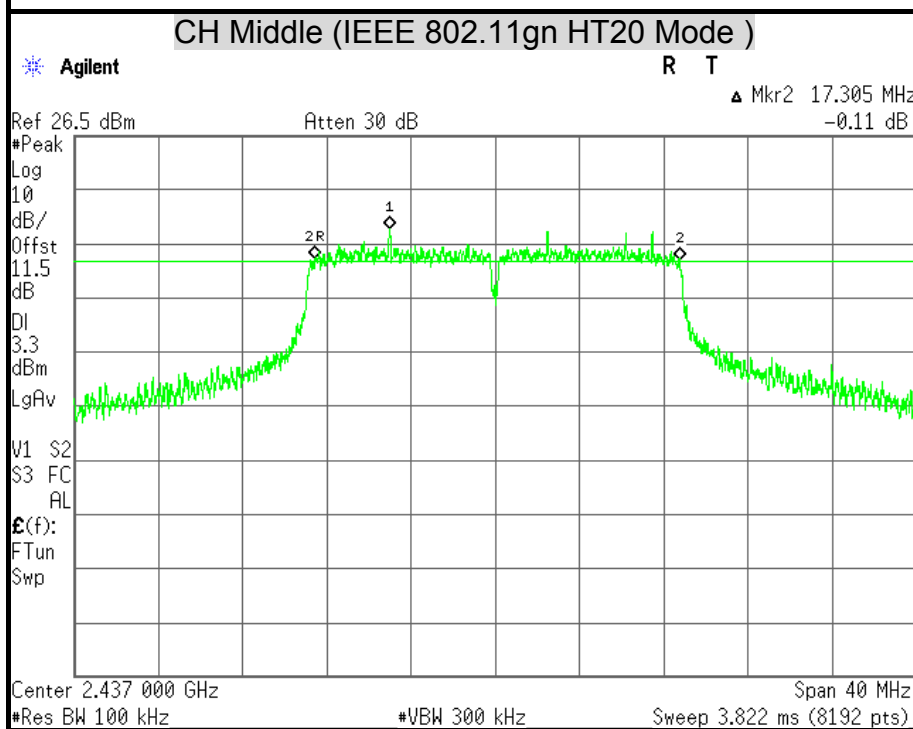
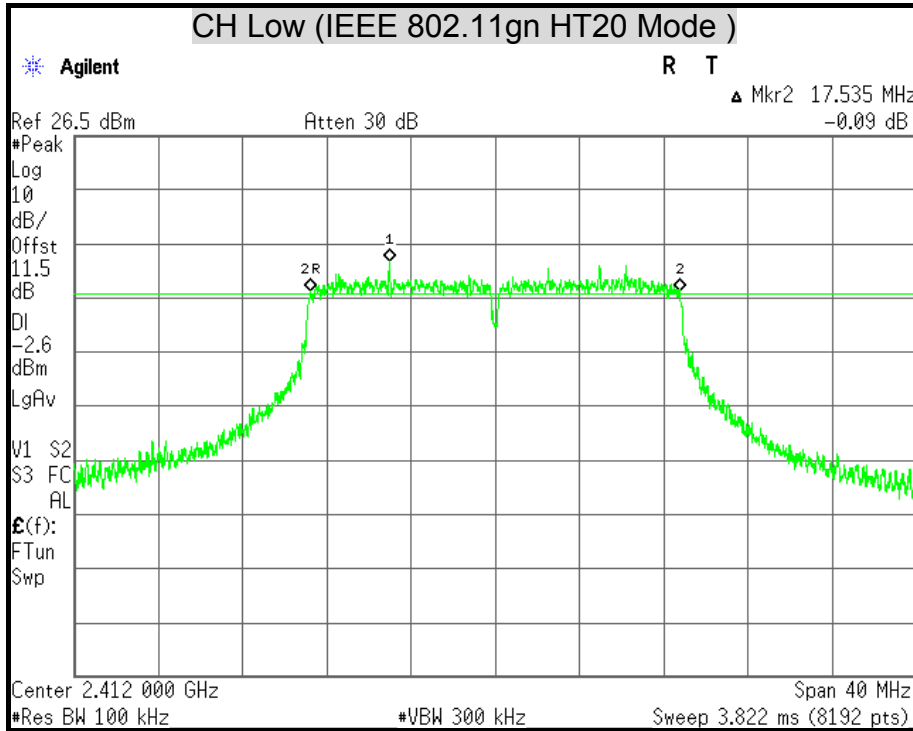

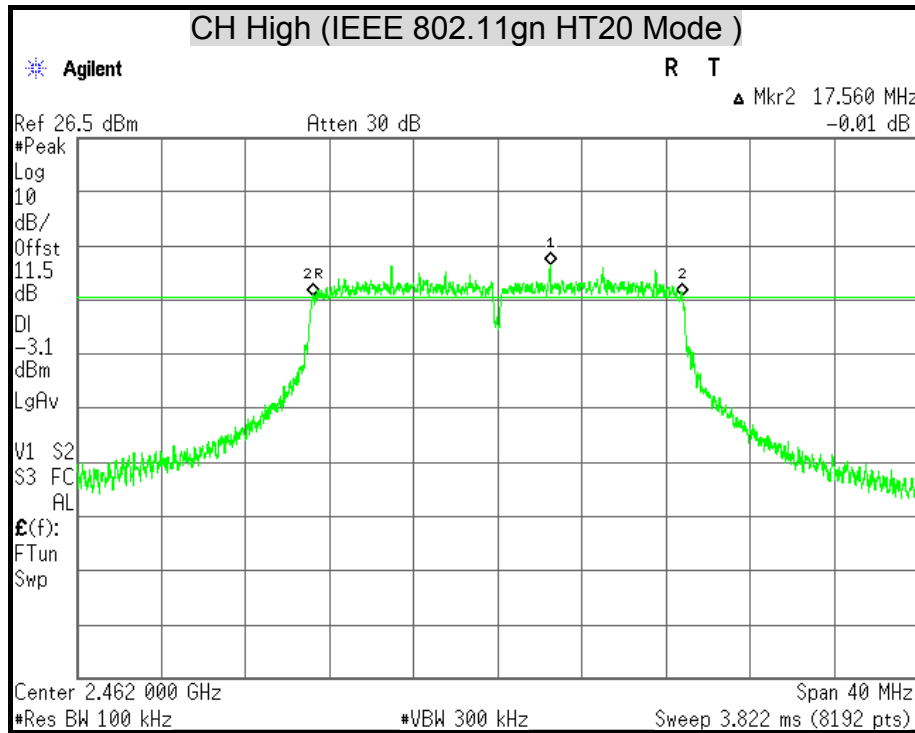

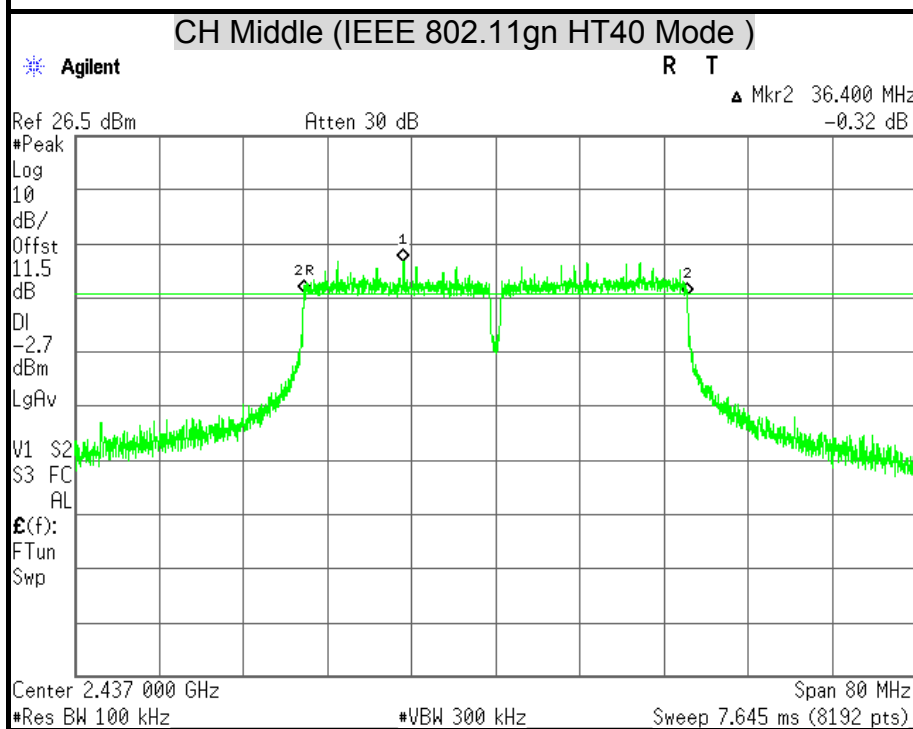
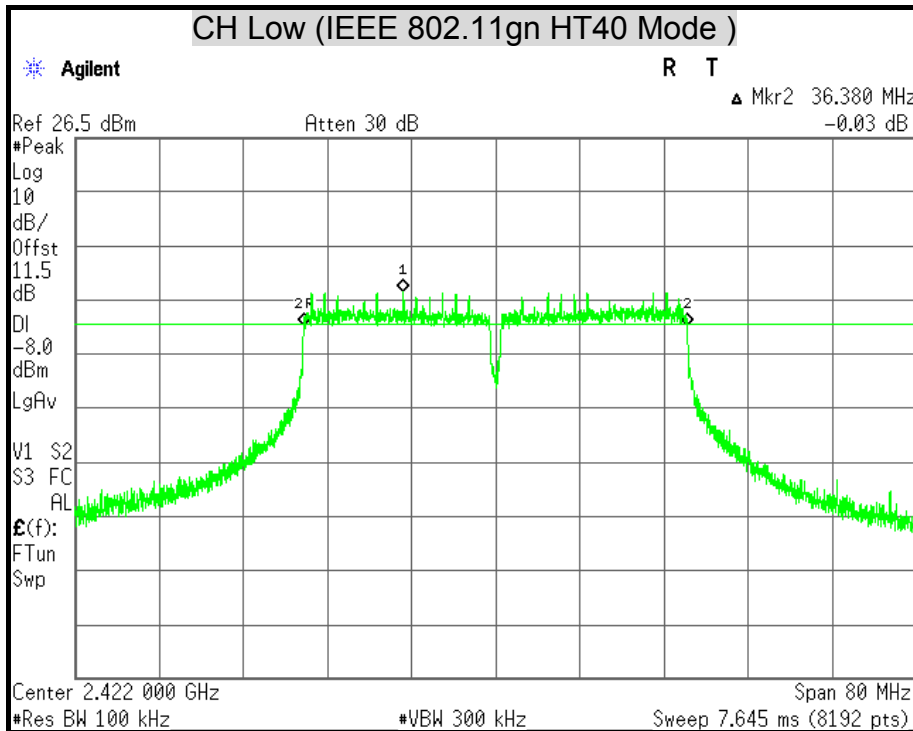

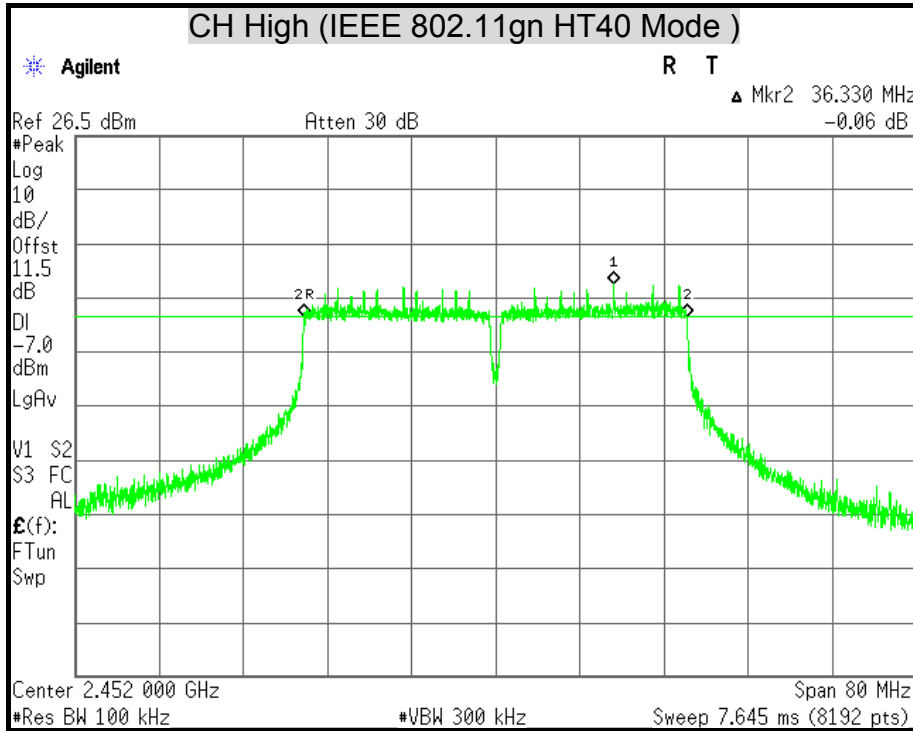

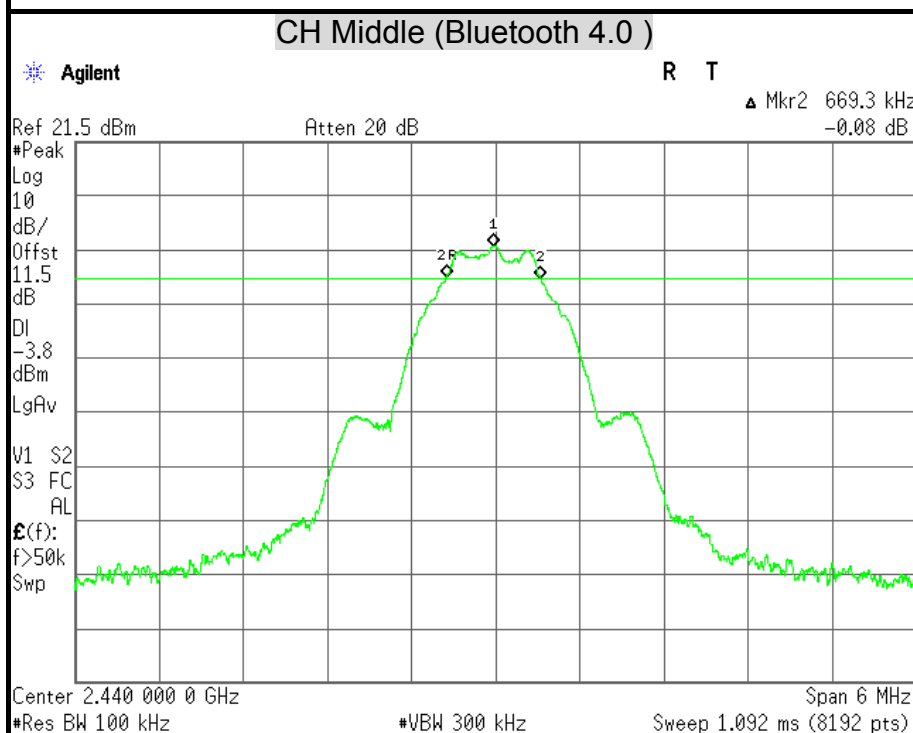
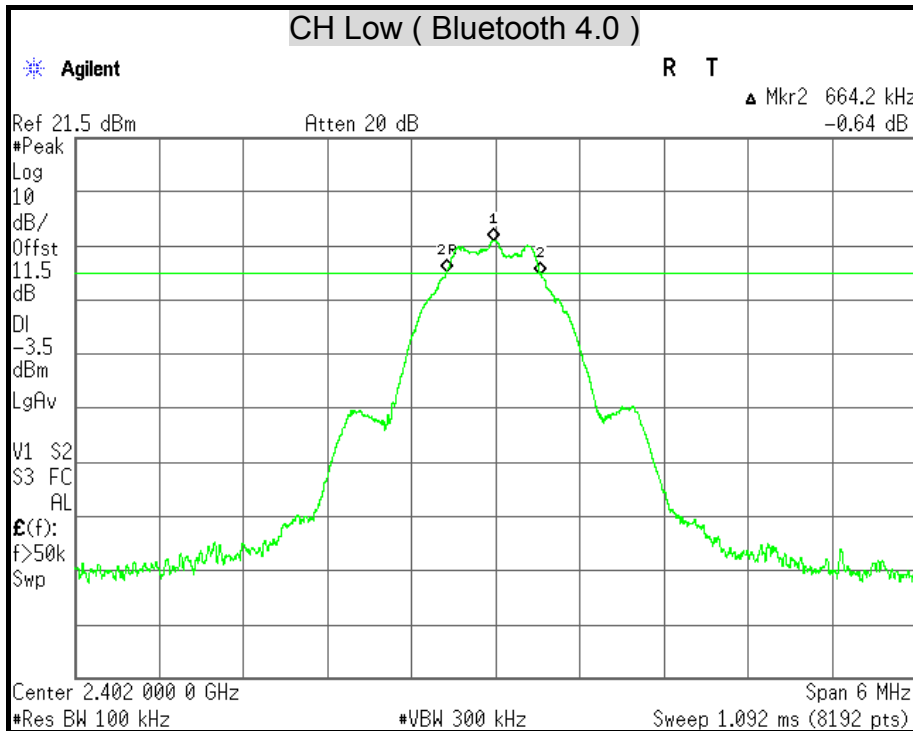

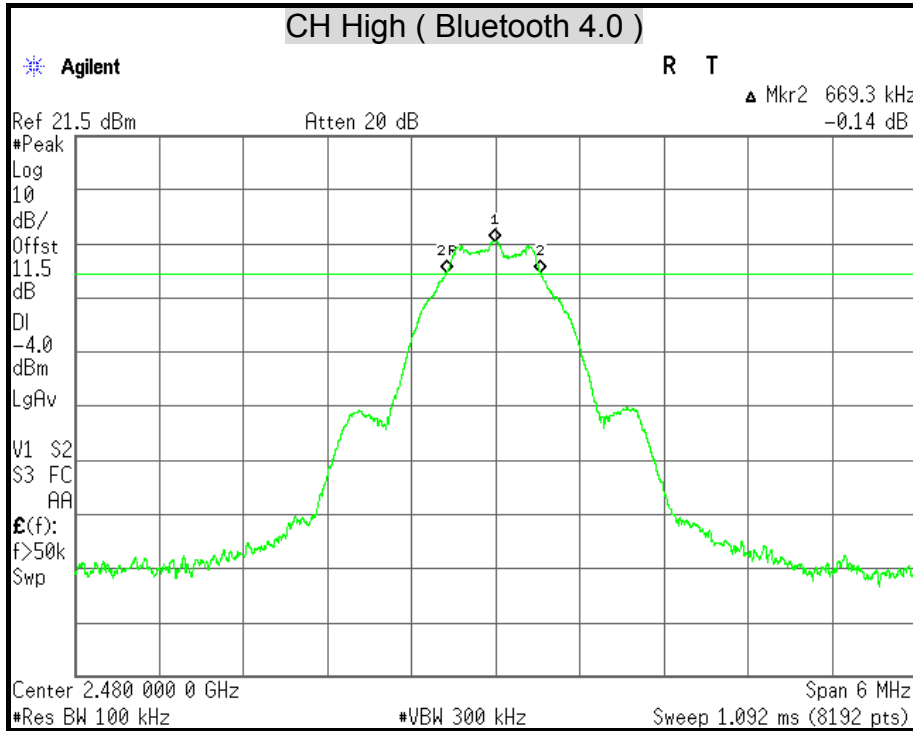



7.2 MAXIMUM PEAK OUTPUT POWER

LIMITS

§ 15.247(b) The maximum peak output power of the intentional radiator shall not exceed the following :

§ 15.247(b) (3) For systems using digital modulation in the 902-928 MHz, 2400-2483.5 MHz, and 5725-5850 MHz bands : 1 watt.

§ 15.247(b) (4) Except as shown in paragraphs (c) of this section, if transmitting antennas of directional gain greater than 6 dBi are used the peak output power from the intentional radiator shall be reduced below the stated values in paragraphs (b)(1) or (b)(2), and (b)(3) of this section, as appropriate, by the amount in dB that the directional gain of the antenna exceeds 6 dBi.

TEST EQUIPMENT

Name of Equipment	Manufacturer	Model	Serial Number	Calibration Due
Power Meter	Anritsu	ML2495A	1149001	12/06/2014
Power Sensor	Anritsu	MA2411B	1126148	12/06/2014

Remark: Each piece of equipment is scheduled for calibration once a year.

TEST SETUP

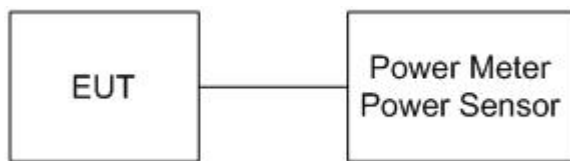

TEST PROCEDURE

The transmitter output is connected to the power meter. The power meter is set to the peak power detection.



TEST RESULTS

IEEE 802.11b Mode

Channel	Channel Frequency (MHz)	Peak Power		Peak Power Limit		Pass / Fail
		(dBm)	(W)	(dBm)	(W)	
Low	2412	20.49	0.1119	30	1	PASS
Middle	2437	23.94	0.2477	30	1	PASS
High	2462	20.36	0.1086	30	1	PASS

Remark:

1. At final test to get the worst-case emission at 1Mbps.
2. The cable assembly insertion loss of 10.5dB (including 10 dB pad and 0.5 dB cable) was Entered as an offset in the power meter to allow for direct reading of power.

IEEE 802.11g Mode

Channel	Channel Frequency (MHz)	Peak Power		Peak Power Limit		Pass / Fail
		(dBm)	(W)	(dBm)	(W)	
Low	2412	23.11	0.2046	30	1	PASS
Middle	2437	26.38	0.4345	30	1	PASS
High	2462	23.02	0.2004	30	1	PASS

Remark:

1. At final test to get the worst-case emission at 6Mbps.
2. The cable assembly insertion loss of 10.5dB (including 10 dB pad and 0.5 dB cable) was Entered as an offset in the power meter to allow for direct reading of power.



IEEE 802.11gn HT20 Mode

Channel	Channel Frequency (MHz)	Peak Power		Peak Power Limit		Pass / Fail
		(dBm)	(W)	(dBm)	(W)	
Low	2412	22.56	0.1803	30	1	PASS
Middle	2437	26.01	0.3990	30	1	PASS
High	2462	22.51	0.1782	30	1	PASS

Remark:

1. At final test to get the worst-case emission at 6.5Mbps.
2. The cable assembly insertion loss of 10.5dB (including 10 dB pad and 0.5 dB cable) was Entered as an offset in the power meter to allow for direct reading of power.

IEEE 802.11gn HT40 Mode

Channel	Channel Frequency (MHz)	Peak Power		Peak Power Limit		Pass / Fail
		(dBm)	(W)	(dBm)	(W)	
Low	2422	20.51	0.1125	30	1	PASS
Middle	2437	24.67	0.2931	30	1	PASS
High	2452	21.00	0.1259	30	1	PASS

Remark:

1. At final test to get the worst-case emission at 13.5Mbps.
2. The cable assembly insertion loss of 10.5dB (including 10 dB pad and 0.5 dB cable) was Entered as an offset in the power meter to allow for direct reading of power.



Bluetooth 4.0 Mode

Channel	Channel Frequency (MHz)	Peak Power		Peak Power Limit		Pass / Fail
		(dBm)	(W)	(dBm)	(W)	
Low	2402	2.63	0.0018	30	1	PASS
Middle	2440	2.47	0.0018	30	1	PASS
High	2480	2.46	0.0018	30	1	PASS

Remark: The cable assembly insertion loss of 10.5 dB (including 10 dB pad and 0.5 dB cable) was Entered as an offset in the power meter to allow for direct reading of power.



7.3 AVERAGE POWER

LIMITS

None; for reporting purposes only.

TEST EQUIPMENT

Name of Equipment	Manufacturer	Model	Serial Number	Calibration Due
Power Meter	ANRITSU	ML2495A	1149001	12/06/2014
Power Sensor	ANRITSU	MA2411B	1126148	12/06/2014

Remark: Each piece of equipment is scheduled for calibration once a year.

TEST SETUP

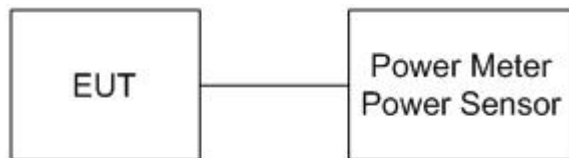

TEST PROCEDURE

The transmitter output is connected to the power meter. The power meter is set to the average power detection.



TEST RESULTS

IEEE 802.11b Mode

Channel	Channel Frequency (MHz)	Average Power (dBm)
Low	2412	18.35
Middle	2437	21.94
High	2462	18.16

Remark:

1. At final test to get the worst-case emission at 1Mbps.
2. The cable assembly insertion loss of 10.5 dB (including 10 dB pad and 0.5 dB cable) was Entered as an offset in the power meter to allow for direct reading of power.

IEEE 802.11g Mode

Channel	Channel Frequency (MHz)	Average Power (dBm)
Low	2412	15.28
Middle	2437	20.88
High	2462	15.30

Remark:

1. At final test to get the worst-case emission at 6Mbps.
2. The cable assembly insertion loss of 10.5 dB (including 10 dB pad and 0.5 dB cable) was Entered as an offset in the power meter to allow for direct reading of power.



IEEE 802.11gn HT20 Mode

Channel	Channel Frequency (MHz)	Average Power (dBm)
Low	2412	14.44
Middle	2437	19.95
High	2462	14.48

Remark:

1. At final test to get the worst-case emission at 6.5Mbps.
2. The cable assembly insertion loss of 10.5 dB (including 10 dB pad and 0.5 dB cable) was Entered as an offset in the power meter to allow for direct reading of power.

IEEE 802.11gn HT40 Mode

Channel	Channel Frequency (MHz)	Average Power (dBm)
Low	2422	12.35
Middle	2437	17.41
High	2452	12.80

Remark:

1. At final test to get the worst-case emission at 13.5Mbps.
2. The cable assembly insertion loss of 10.5 dB (including 10 dB pad and 0.5 dB cable) was Entered as an offset in the power meter to allow for direct reading of power.

Bluetooth 4.0 Mode

Channel	Channel Frequency (MHz)	Average Power (dBm)
Low	2402	2.39
Middle	2440	2.22
High	2480	2.21

Remark: The cable assembly insertion loss of 10.5 dB (including 10 dB pad and 0.5 dB cable) was Entered as an offset in the power meter to allow for direct reading of power.



7.4 POWER SPECTRAL DENSITY

LIMITS

§ 15.247(e) For digitally modulated systems, the power spectral density conducted from the intentional radiator to the antenna shall not greater than 8 dBm in any 3 kHz band during any time interval of continuous transmission.

TEST EQUIPMENT

Name of Equipment	Manufacturer	Model	Serial Number	Calibration Due
Spectrum Analyzer	Agilent	E4446A	MY43360132	06/10/2015

Remark: Each piece of equipment is scheduled for calibration once a year.

TEST SETUP



TEST PROCEDURE

1. The transmitter output was connected to the spectrum analyzer.
2. Set analyzer center frequency to DTS channel center frequency.
3. Set the span to 1.5 times the DTS channel bandwidth.
4. Set the RBW to: $3 \text{ kHz} \leq \text{RBW} \leq 100 \text{ kHz}$.
5. Set the VBW $\geq 3 \times \text{RBW}$.
6. Detector = peak.
7. Sweep time = auto couple.
8. Trace mode = max hold.
9. Allow trace to fully stabilize.
10. Use the peak marker function to determine the maximum amplitude level within the RBW.
11. If measured value exceeds limit, reduce RBW (no less than 3 kHz) and repeat.



TEST RESULTS

IEEE 802.11b Mode

Channel	Channel Frequency (MHz)	Final RF Power Level in 3KHz BW (dBm)	Minimum Limit (dBm)	Pass / Fail
Low	2412	-4.30	8	PASS
Middle	2437	-0.10	8	PASS
High	2462	-5.23	8	PASS

Remark:

1. At final test to get the worst-case emission at 1Mbps.
2. The cable assembly insertion loss of 10.5dB (including 10 dB pad and 0.5 dB cable) was Entered as an offset in the spectrum analyzer to allow for direct reading of power.

IEEE 802.11g Mode

Channel	Channel Frequency (MHz)	Final RF Power Level in 3KHz BW (dBm)	Minimum Limit (dBm)	Pass / Fail
Low	2412	-8.76	8	PASS
Middle	2437	-4.32	8	PASS
High	2462	-9.33	8	PASS

Remark:

1. At final test to get the worst-case emission at 6Mbps.
2. The cable assembly insertion loss of 10.5dB (including 10 dB pad and 0.5 dB cable) was Entered as an offset in the spectrum analyzer to allow for direct reading of power.



IEEE 802.11gn HT20 Mode

Channel	Channel Frequency (MHz)	Final RF Power Level in 3KHz BW (dBm)	Minimum Limit (dBm)	Pass / Fail
Low	2412	-11.61	8	PASS
Middle	2437	-5.53	8	PASS
High	2462	-10.57	8	PASS

Remark:

1. At final test to get the worst-case emission at 6.5Mbps.
2. The cable assembly insertion loss of 10.5dB (including 10 dB pad and 0.5 dB cable) was Entered as an offset in the spectrum analyzer to allow for direct reading of power.

IEEE 802.11gn HT40 Mode

Channel	Channel Frequency (MHz)	Final RF Power Level in 3KHz BW (dBm)	Minimum Limit (dBm)	Pass / Fail
Low	2422	-15.53	8	PASS
Middle	2437	-11.24	8	PASS
High	2452	-15.88	8	PASS

Remark:

1. At final test to get the worst-case emission at 13.5Mbps.
2. The cable assembly insertion loss of 10.5dB (including 10 dB pad and 0.5 dB cable) was Entered as an offset in the spectrum analyzer to allow for direct reading of power.



Bluetooth 4.0 Mode

Channel	Channel Frequency (MHz)	Final RF Power Level in 3KHz BW (dBm)	Minimum Limit (dBm)	Pass / Fail
Low	2402	-7.13	8	PASS
Middle	2440	-7.47	8	PASS
High	2480	-7.63	8	PASS

Remark: The cable assembly insertion loss of 10.5 dB (including 10 dB pad and 0.5 dB cable) was Entered as an offset in the spectrum analyzer to allow for direct reading of power.



POWER SPECTRAL DENSITY

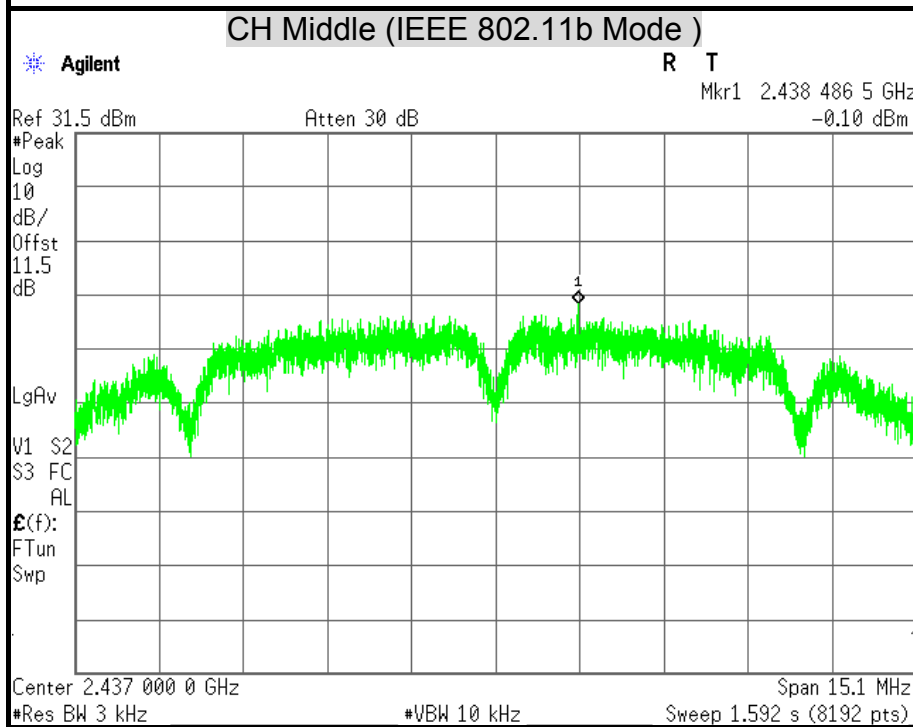
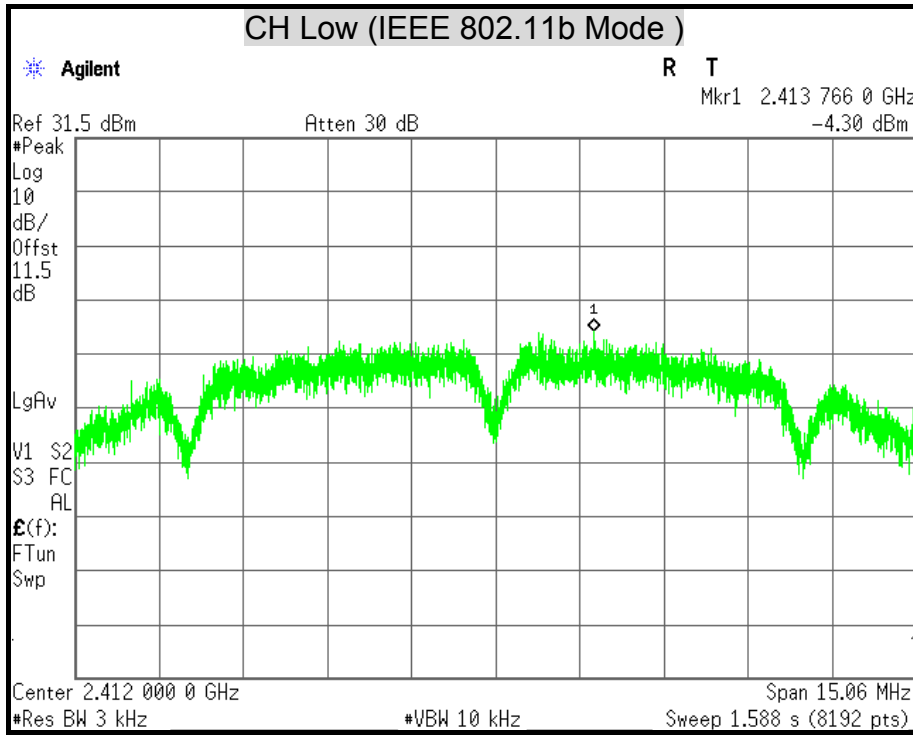

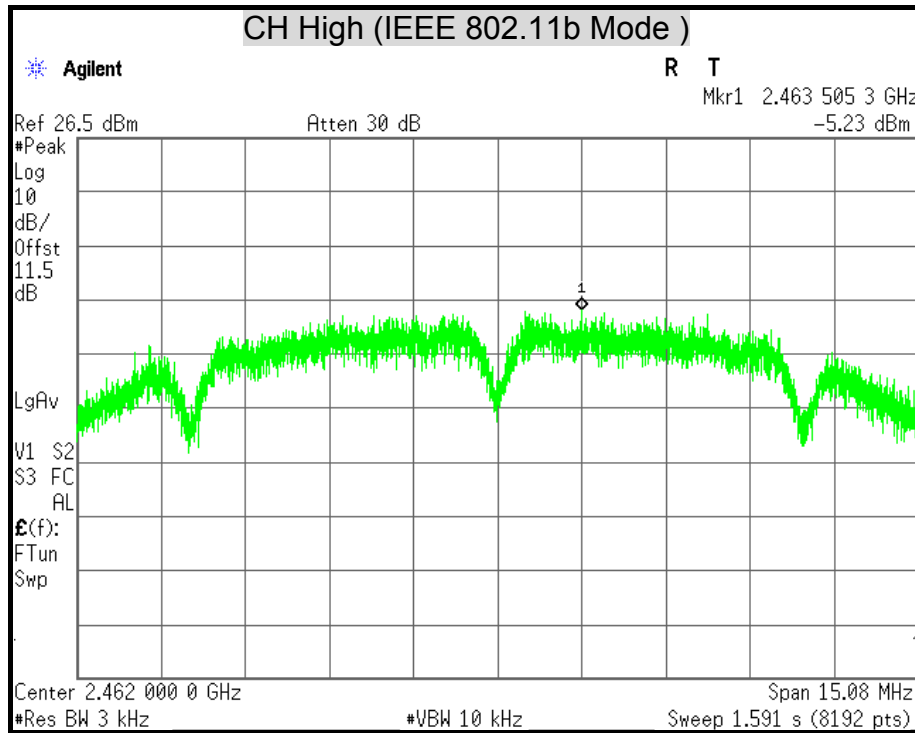

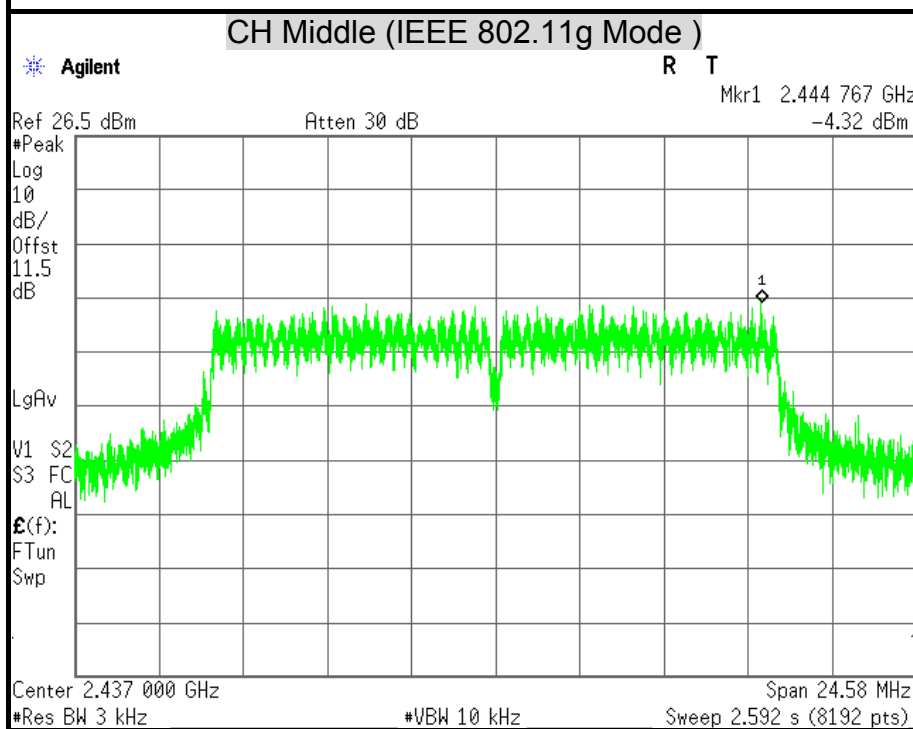
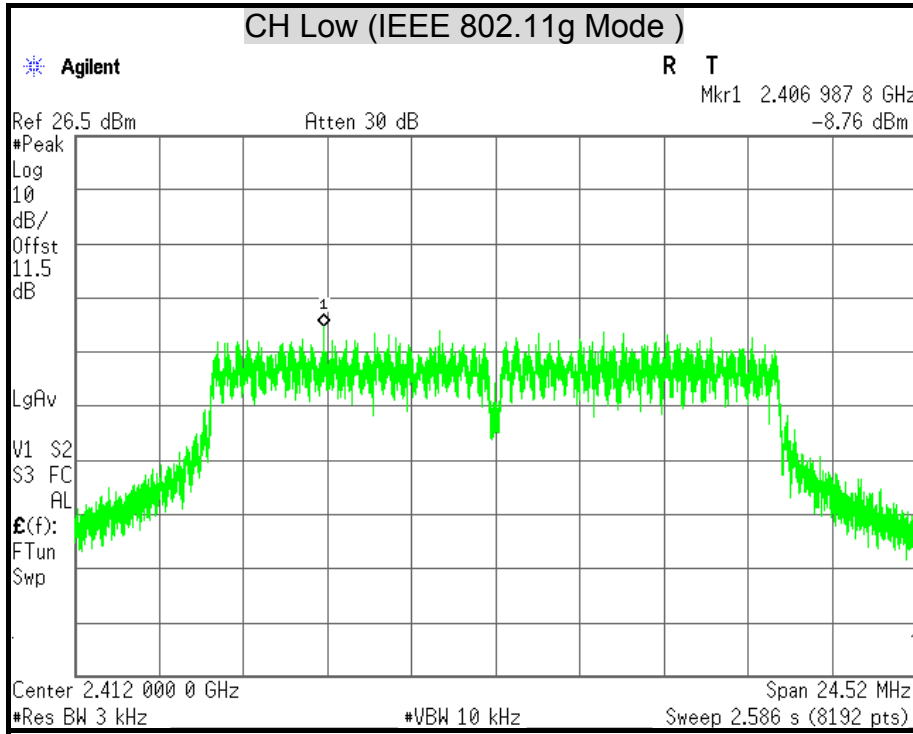

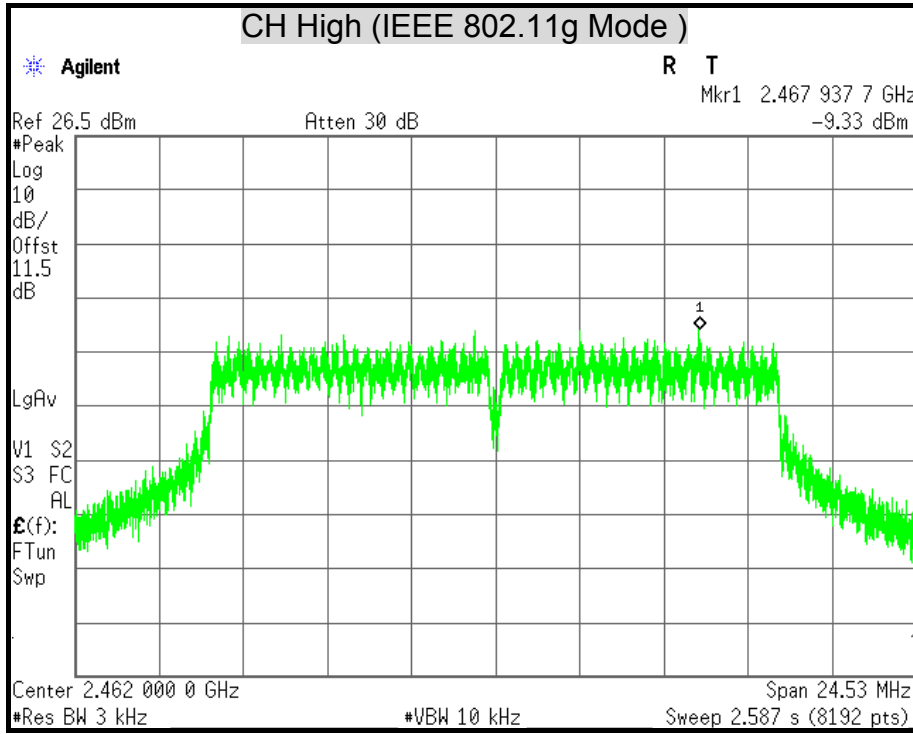

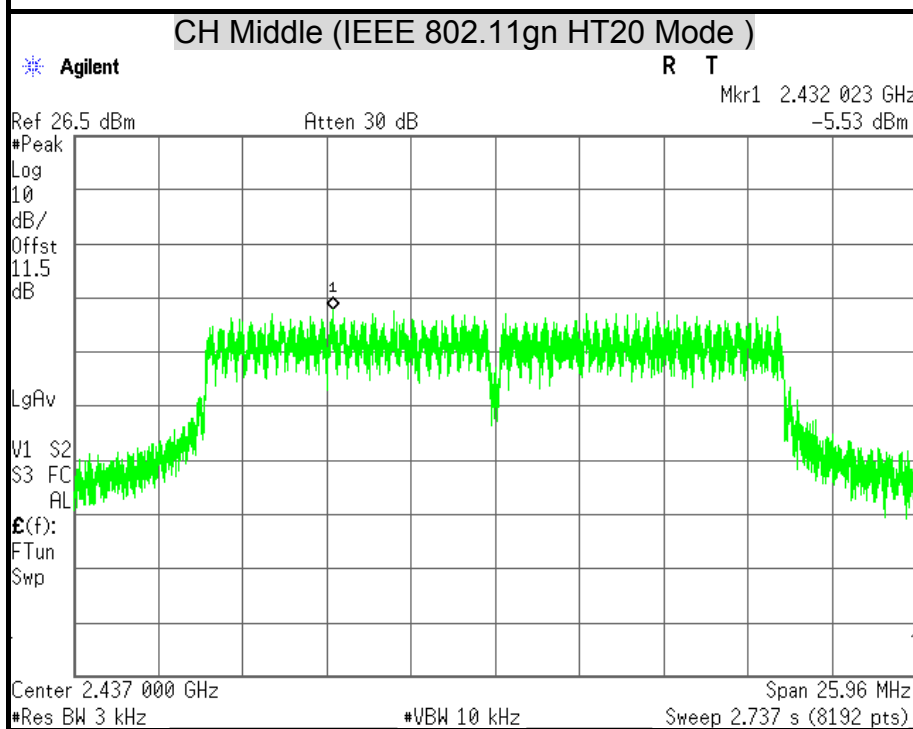
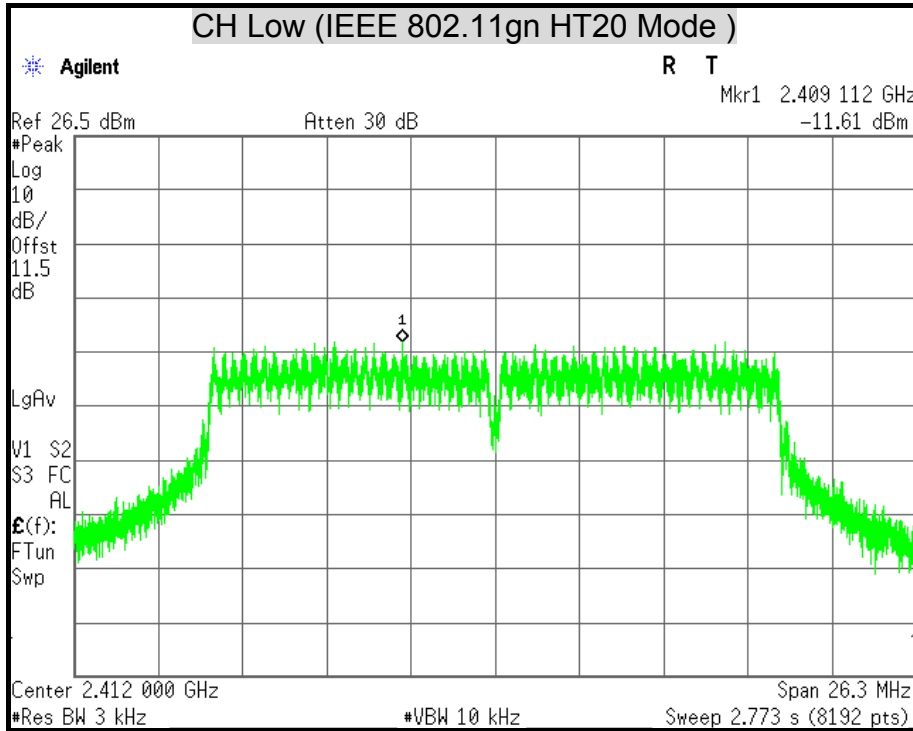

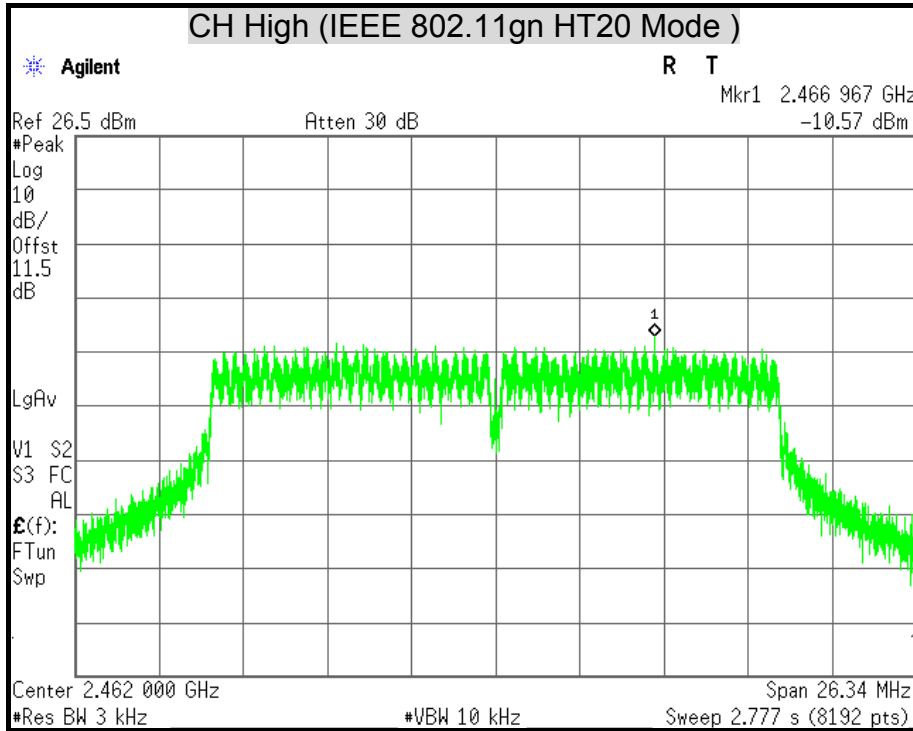

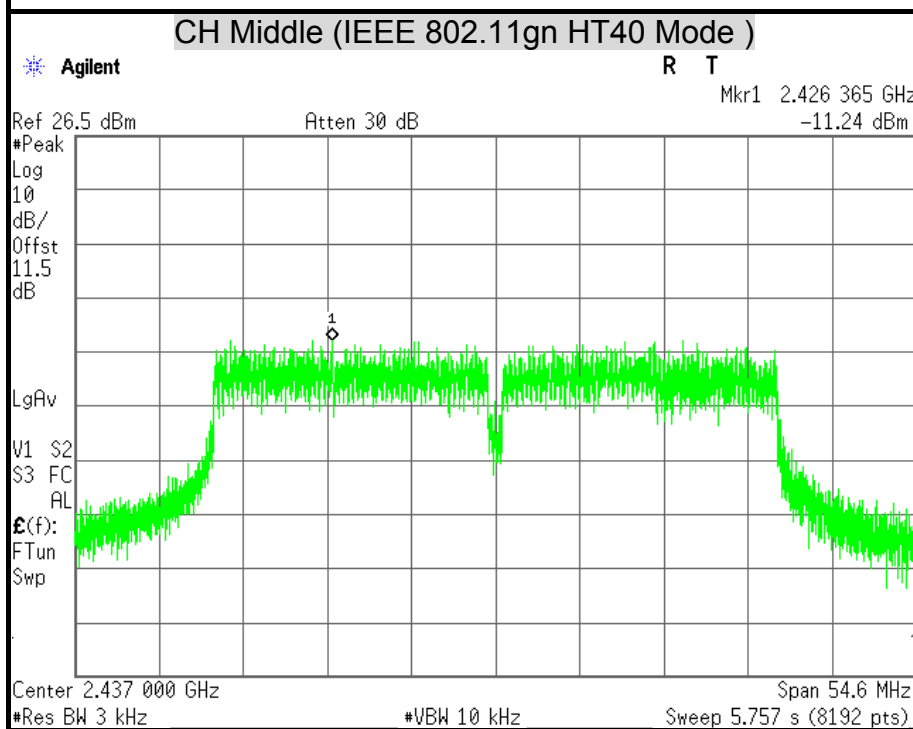
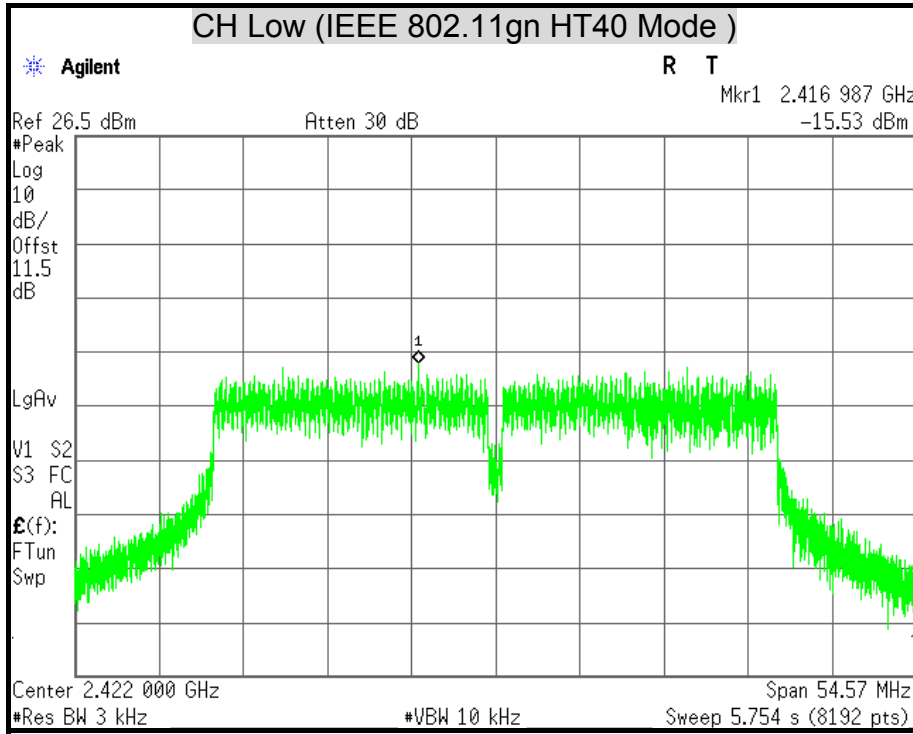

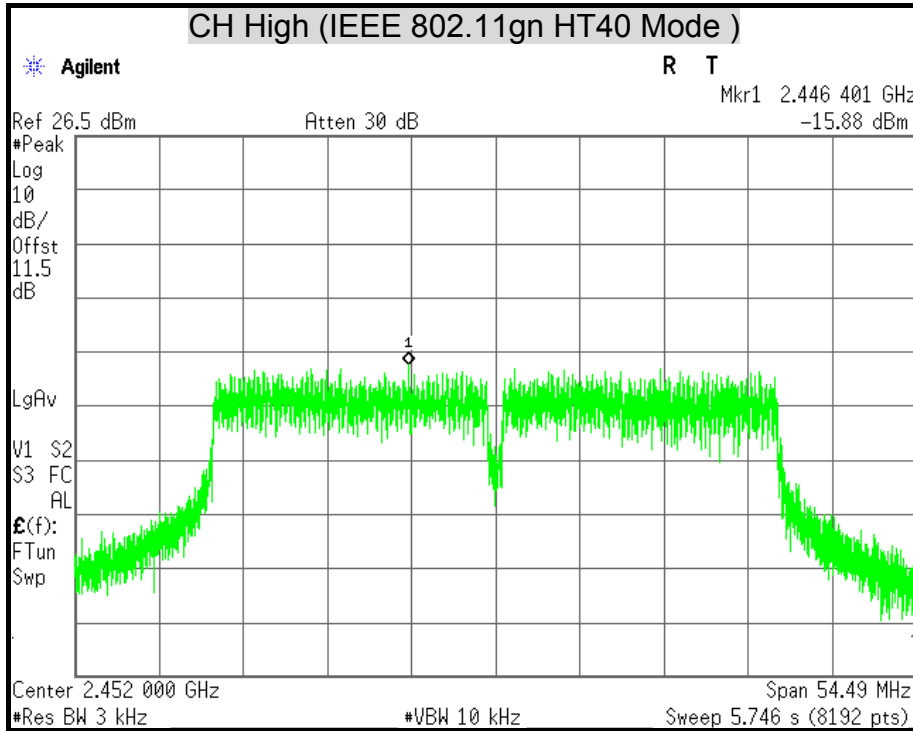

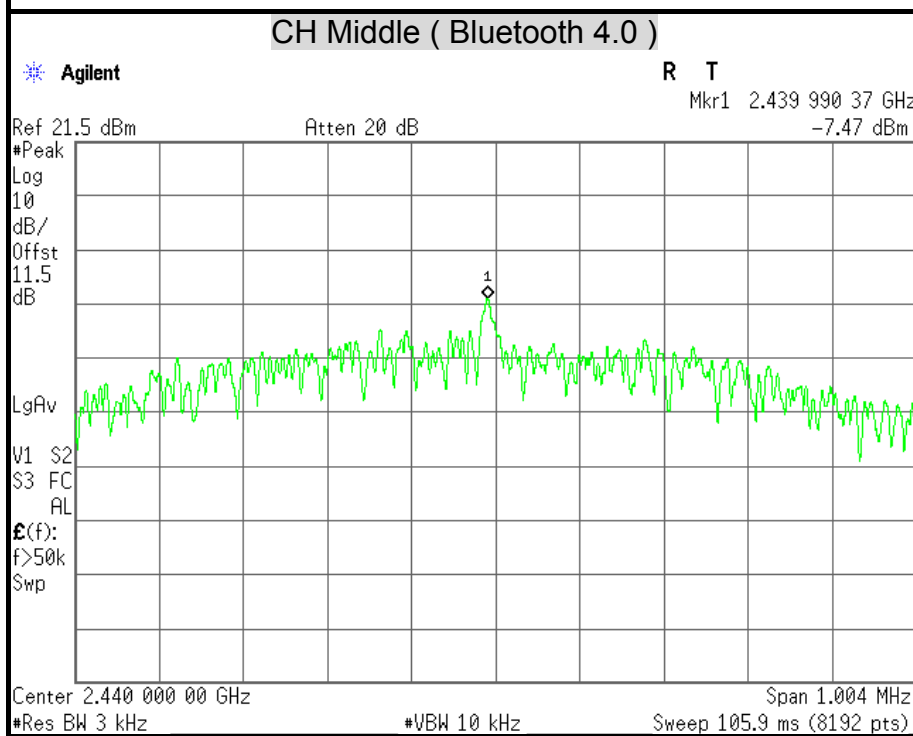
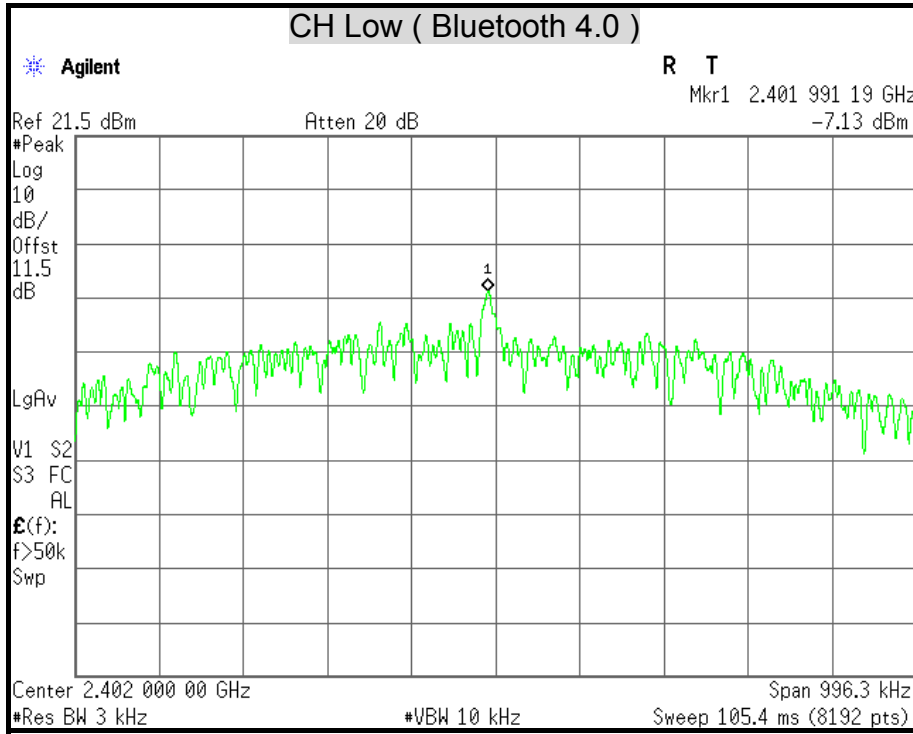

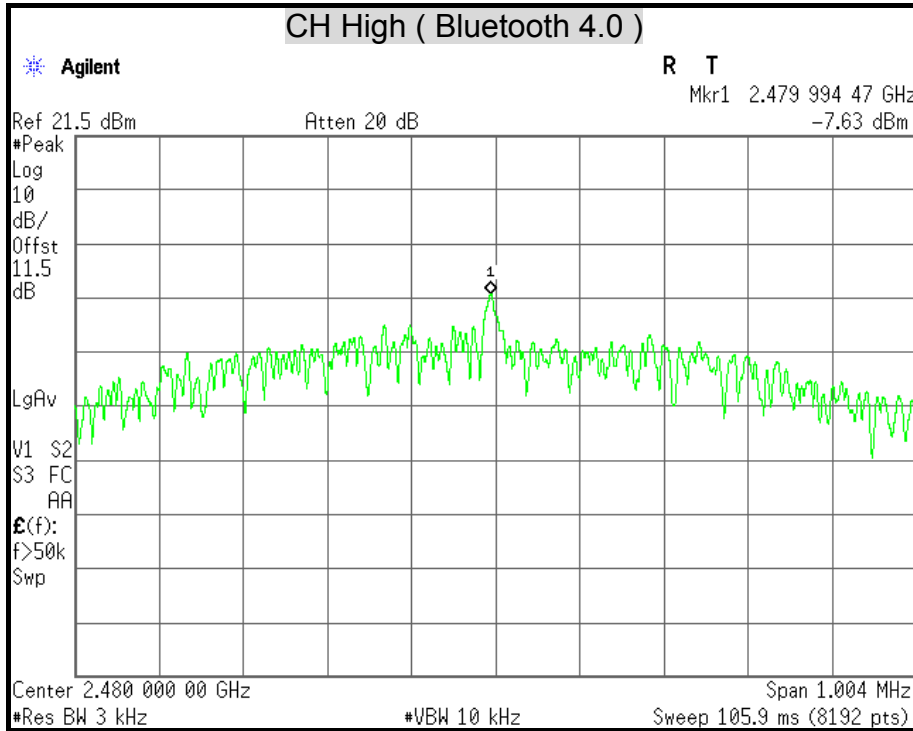



7.5 CONDUCTED SPURIOUS EMISSION

LIMITS

§ 15.247(d) In any 100 kHz bandwidth outside the frequency band in which the spread spectrum intentional radiator is operating, the radio frequency power that is produced by the intentional radiator shall be at least 20 dB below that in the 100 kHz bandwidth within the band that contains the highest level of the desired power, based on either an RF conducted or a radiated measurement. Attenuation below the general limits specified in § 15.209(a) is not required. In addition, radiated emissions which fall in the restricted bands, as defined in § 15.205(a), must also comply with the radiated emission limits specified in § 15.209(a) (see § 15.205(c)).

TEST EQUIPMENT

Name of Equipment	Manufacturer	Model	Serial Number	Calibration Due
Spectrum Analyzer	Agilent	E4446A	MY43360132	06/10/2015

Remark: Each piece of equipment is scheduled for calibration once a year.

TEST SETUP

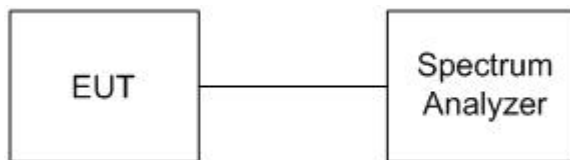

TEST PROCEDURE

The transmitter output is connected to a spectrum analyzer. The resolution bandwidth is set to 100 kHz. The video bandwidth is set to 300 kHz.

The spectrum from 30 MHz to 26.5 GHz is investigated with the transmitter set to the lowest, middle, and highest channels in the 2.4 GHz band.



TEST RESULTS

OUT-OF-BAND SPURIOUS EMISSIONS-CONDUCTED MEASUREMENT

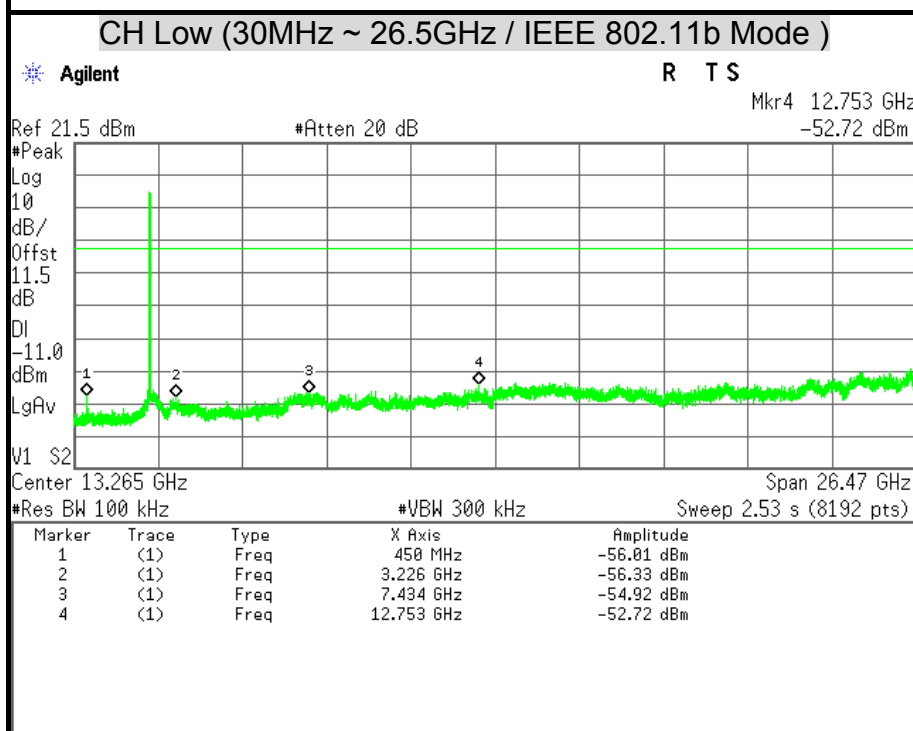
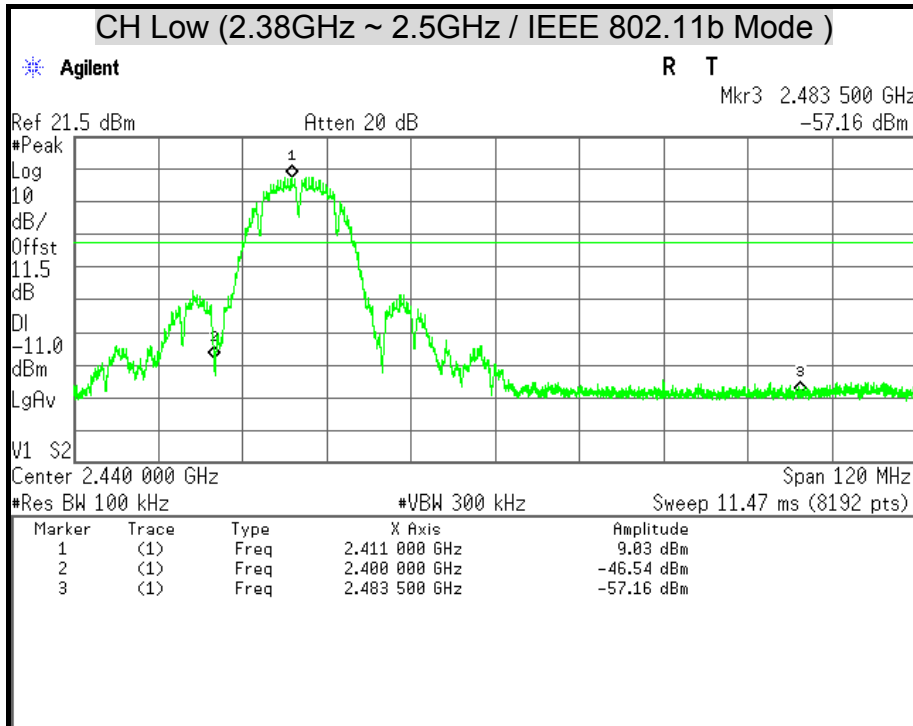

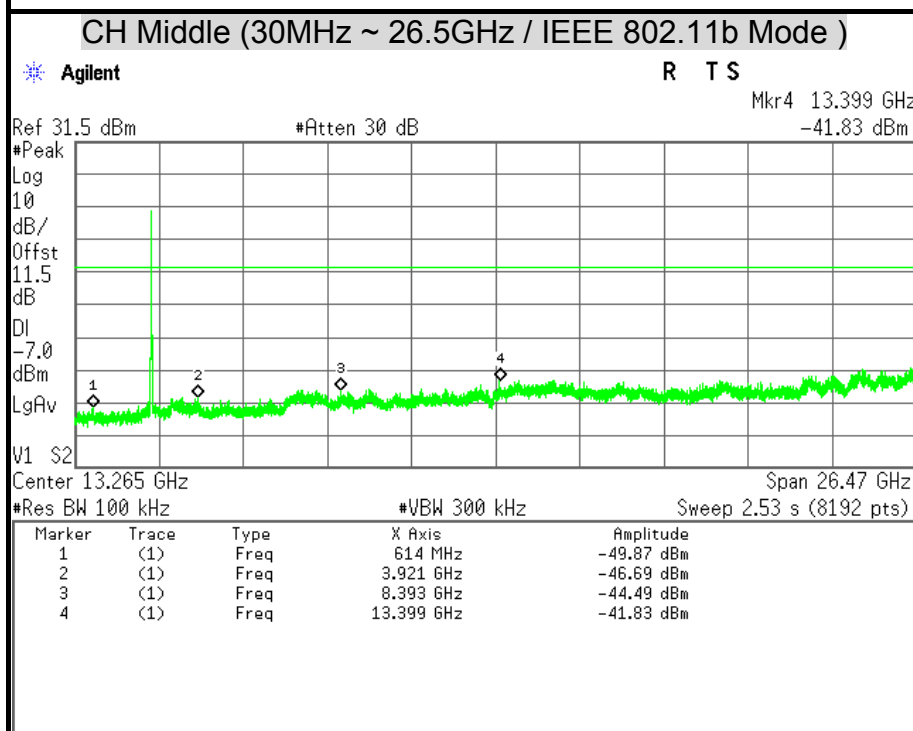
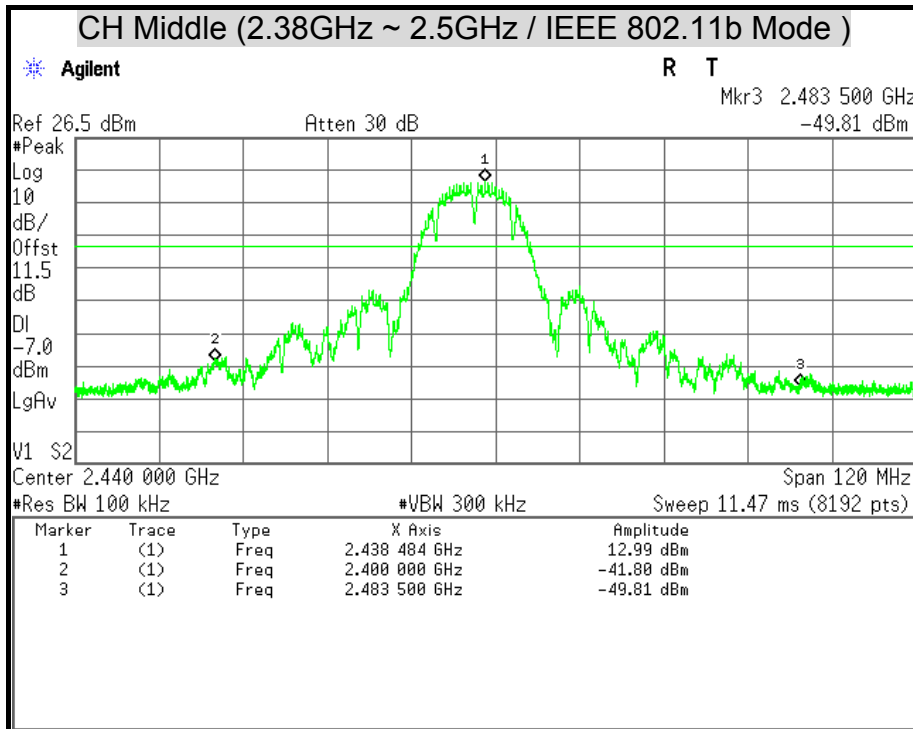

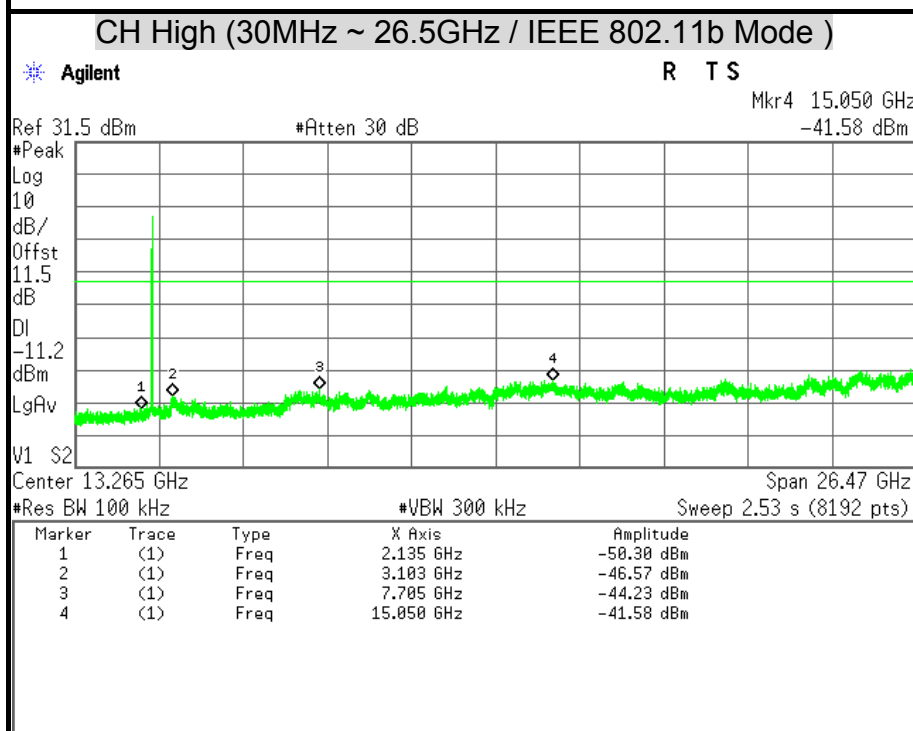
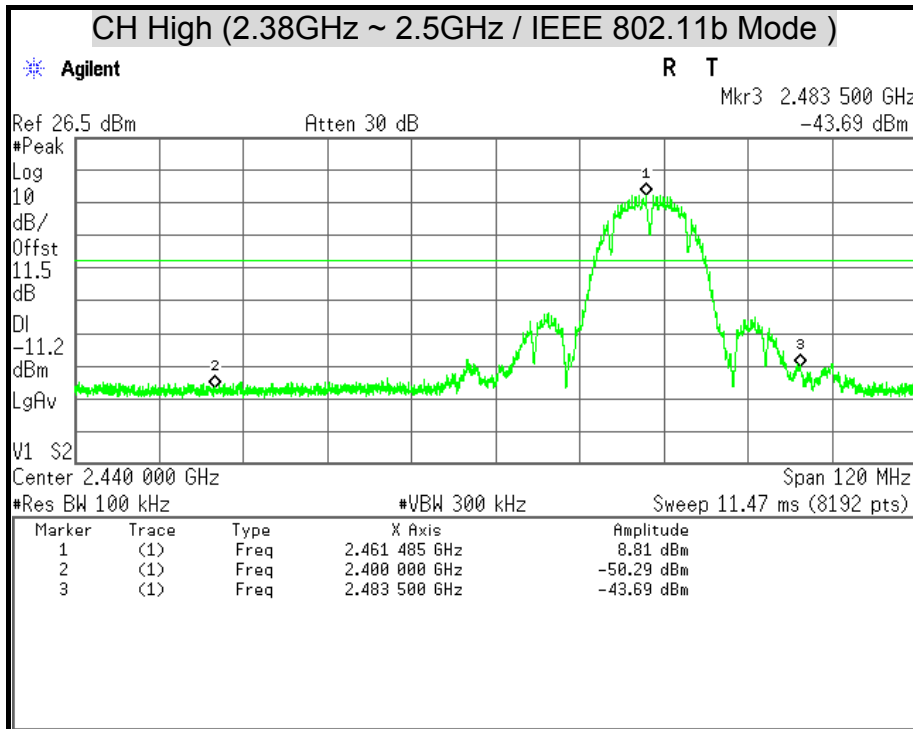

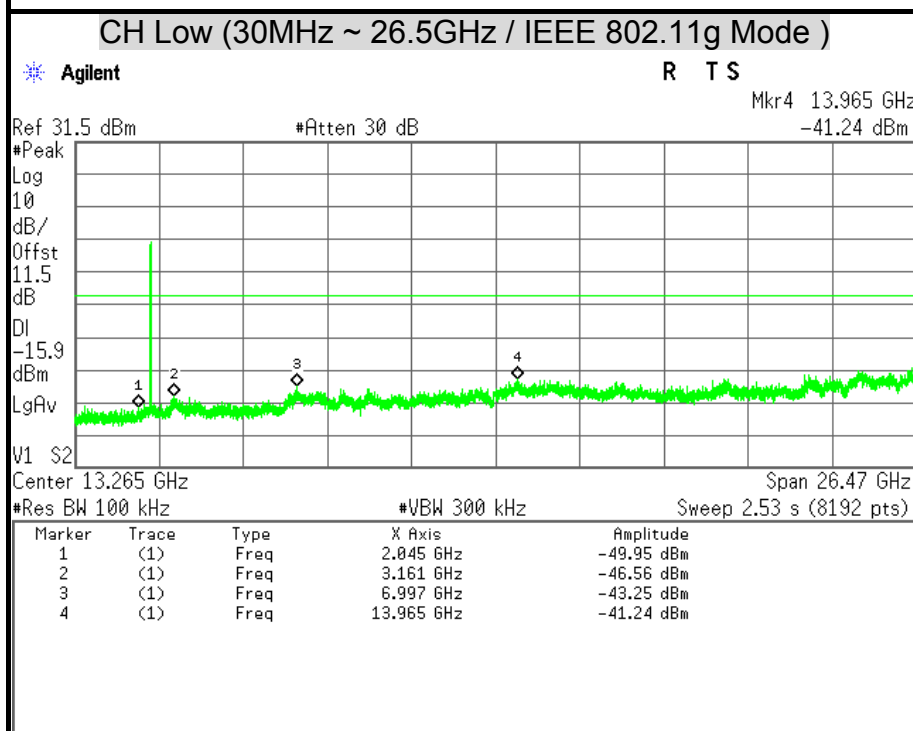
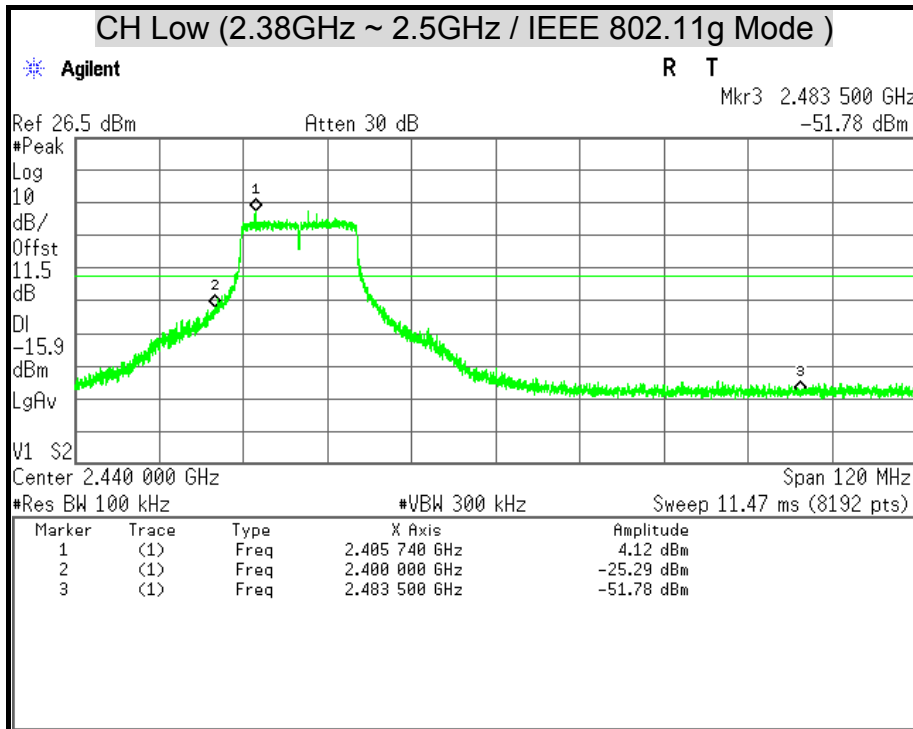

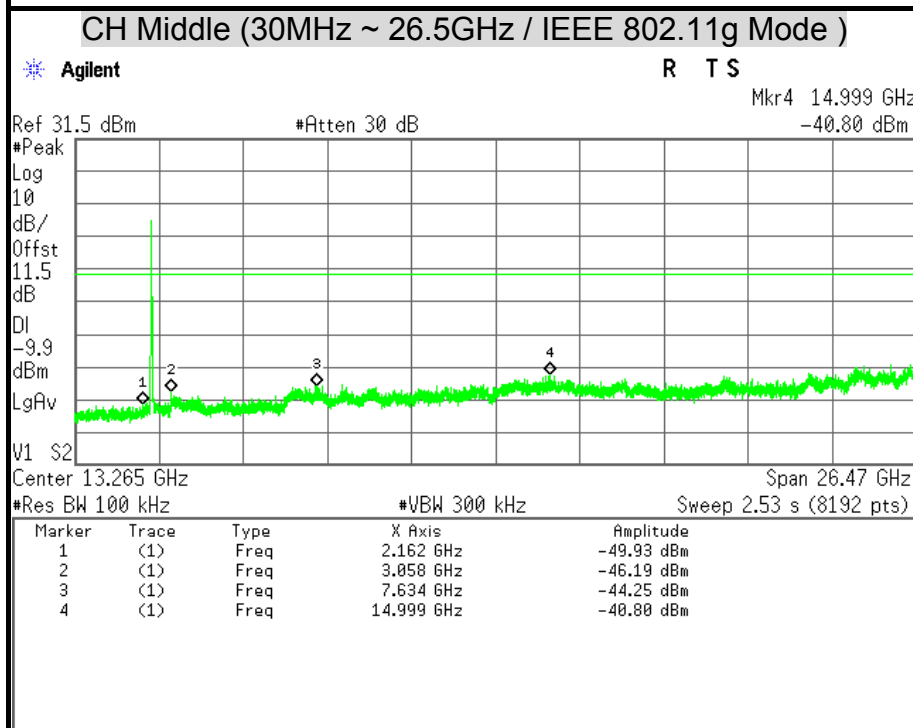
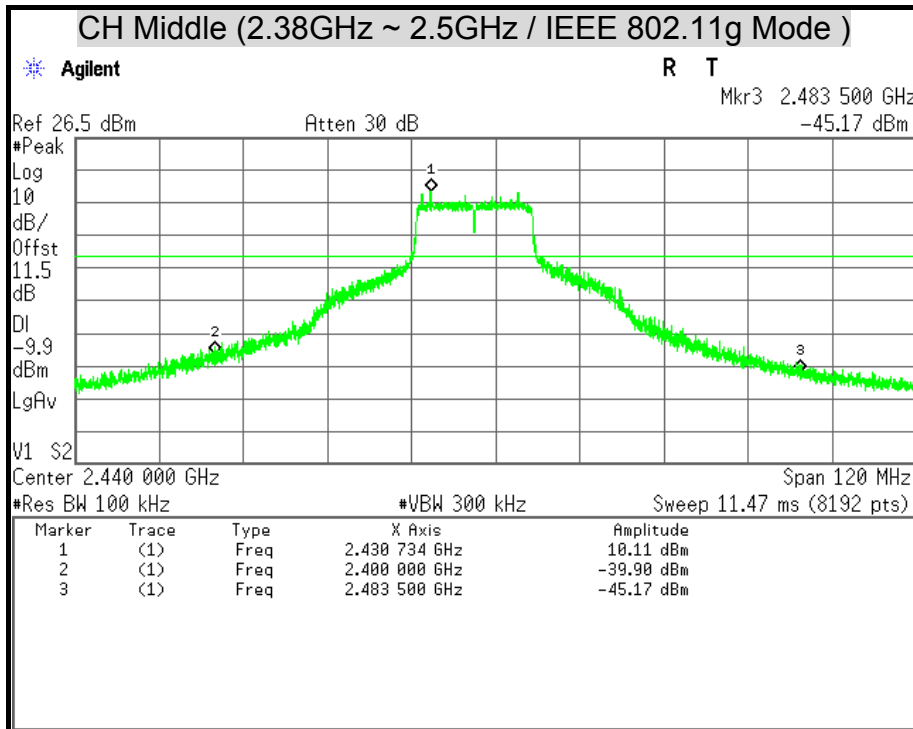

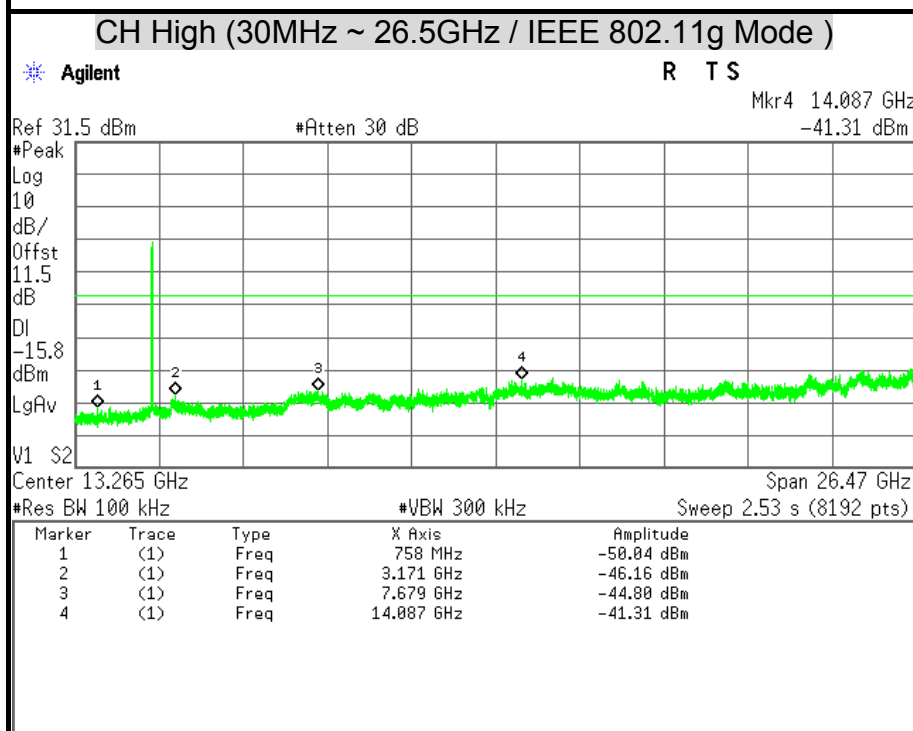
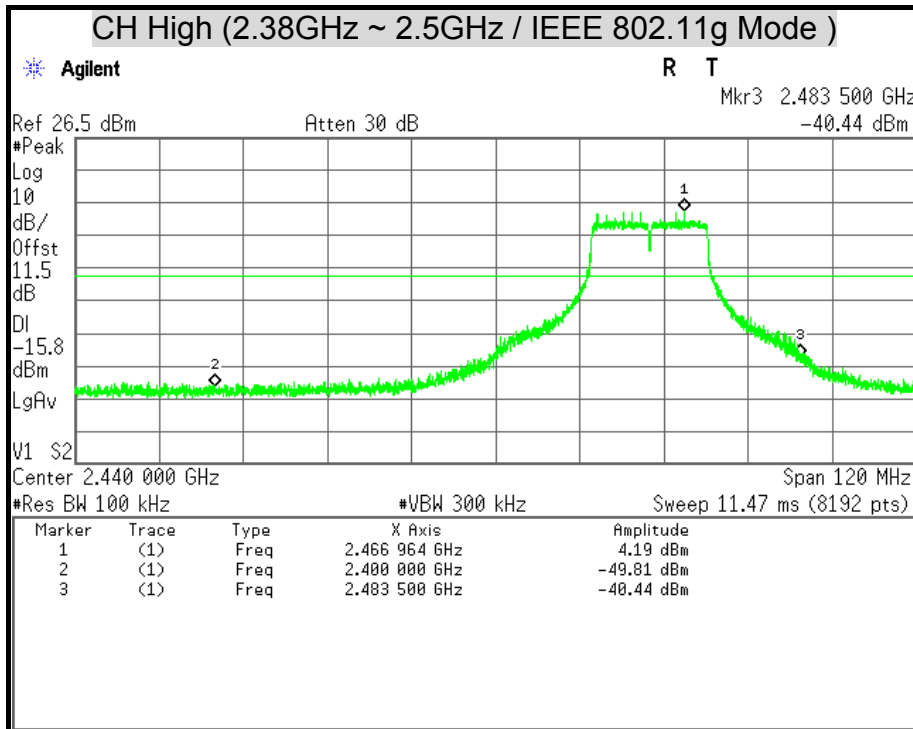

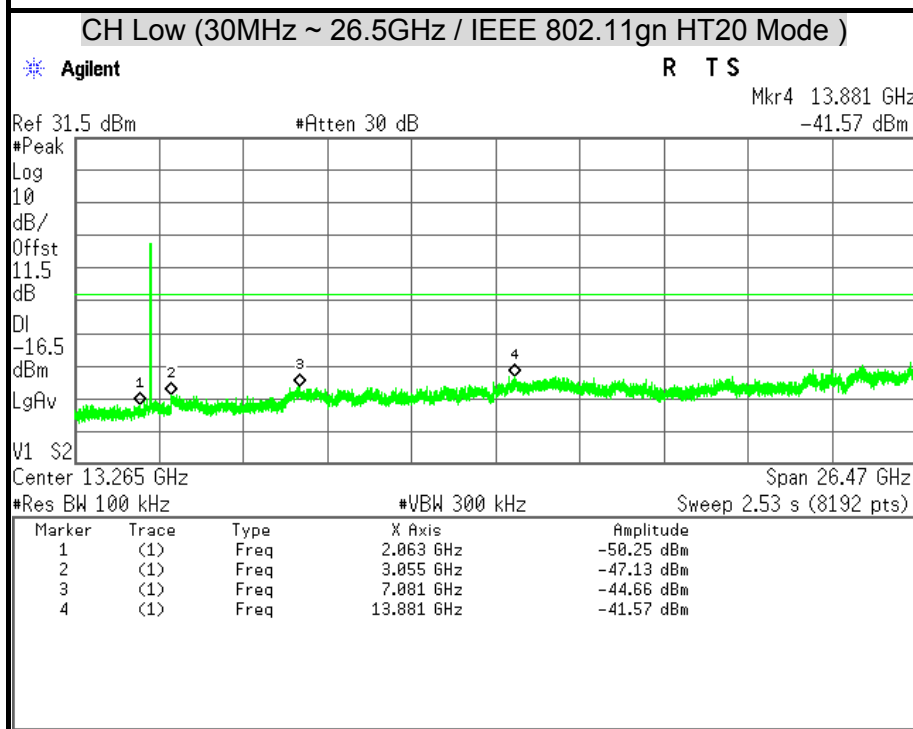
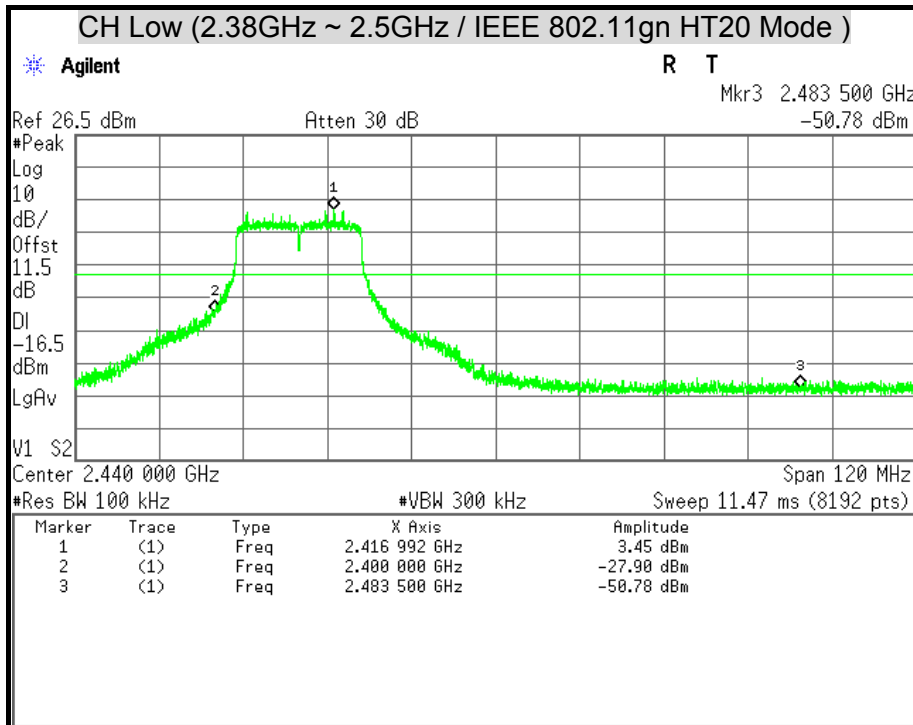

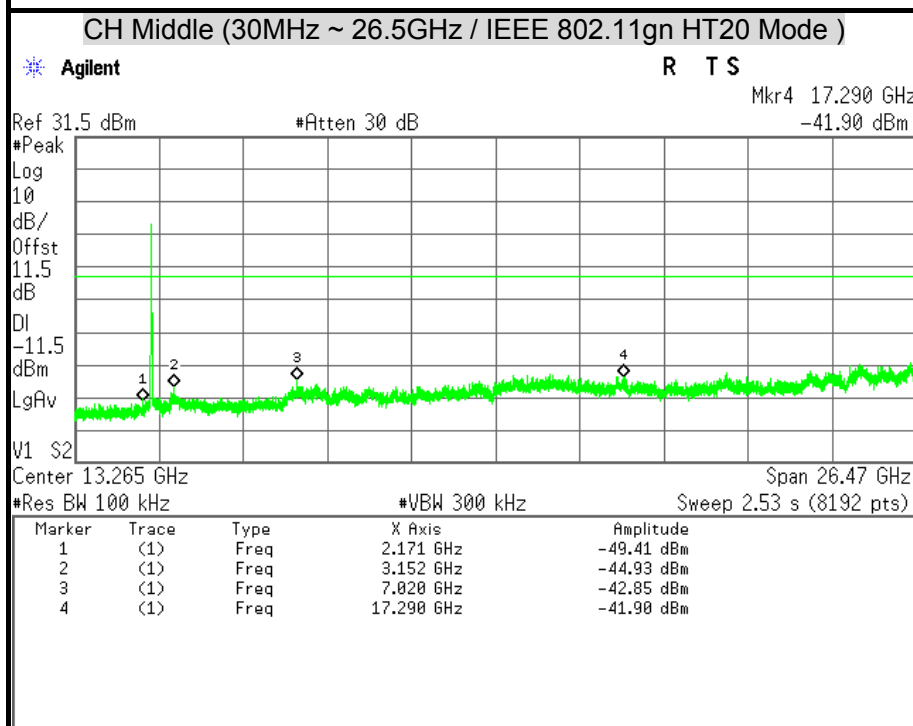
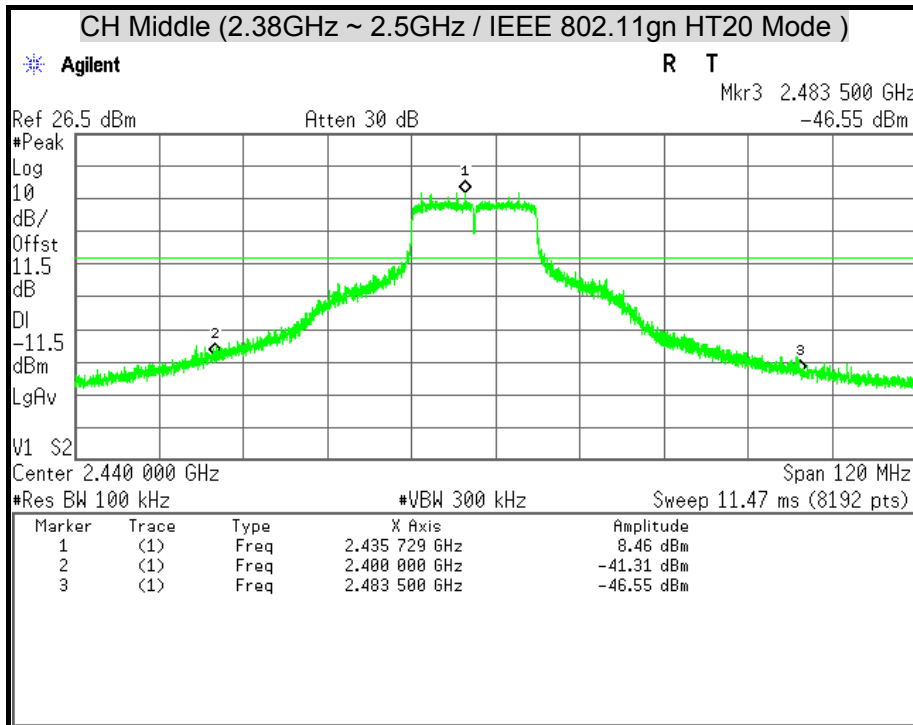

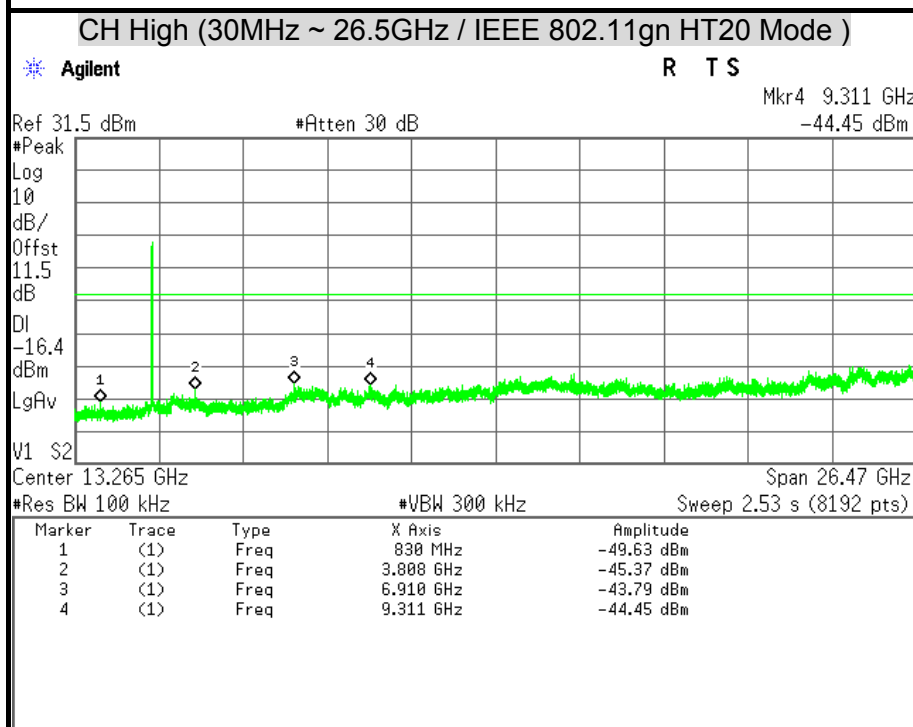
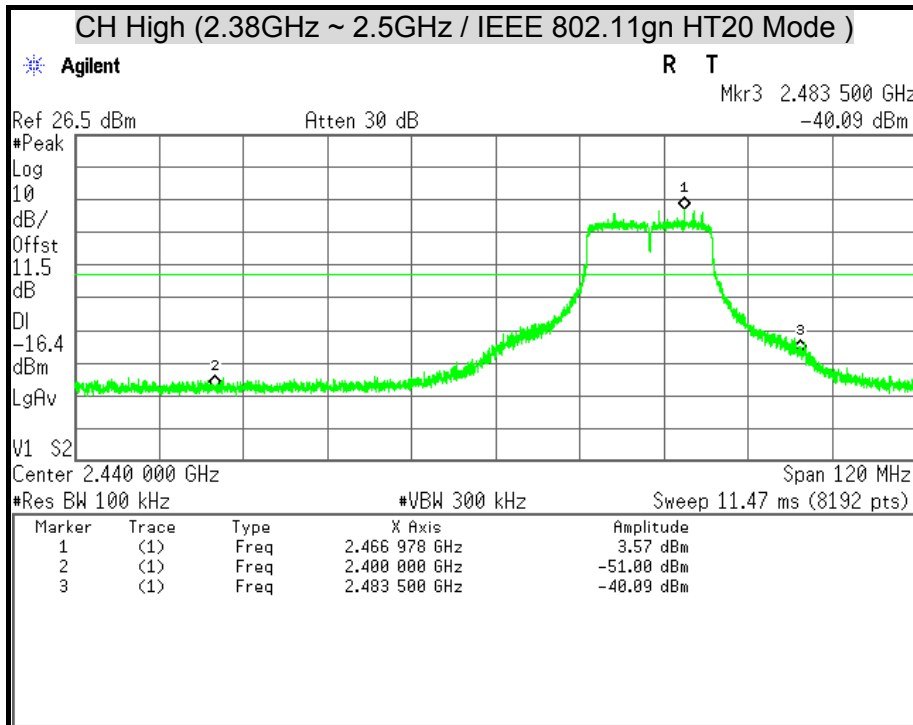

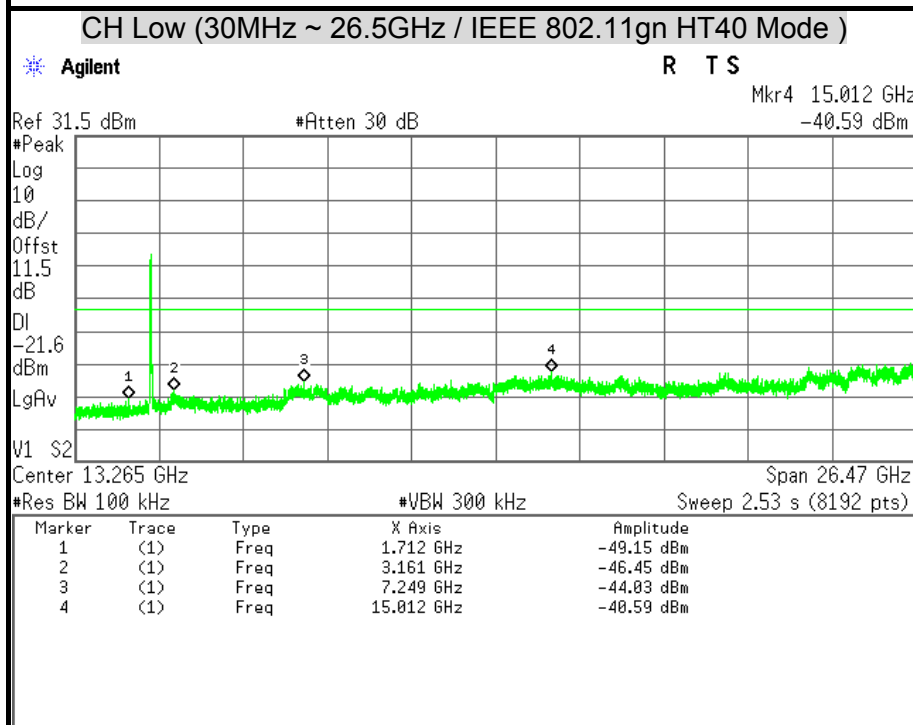
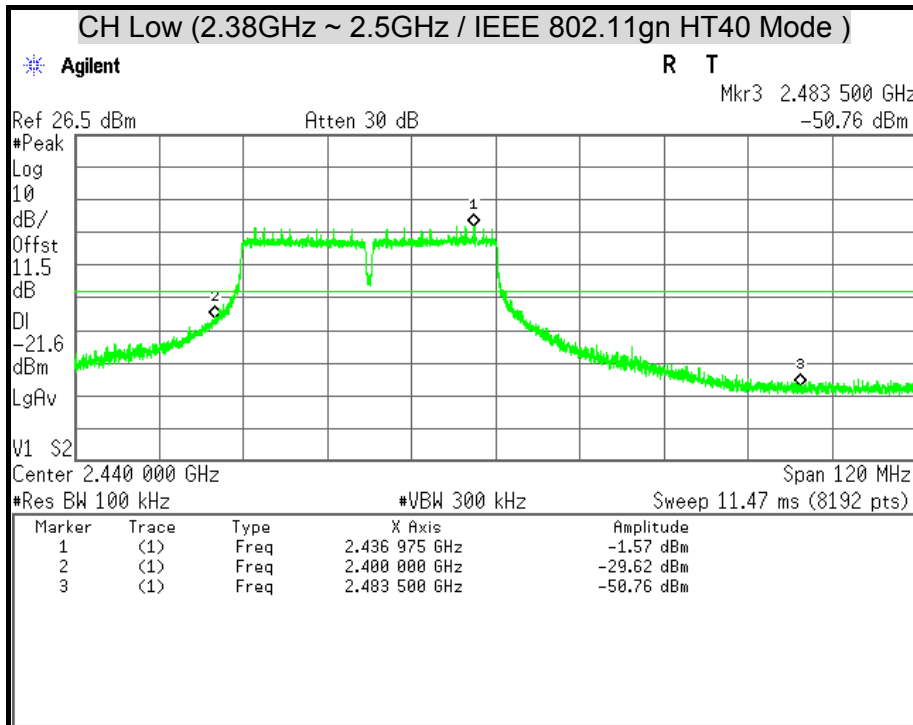

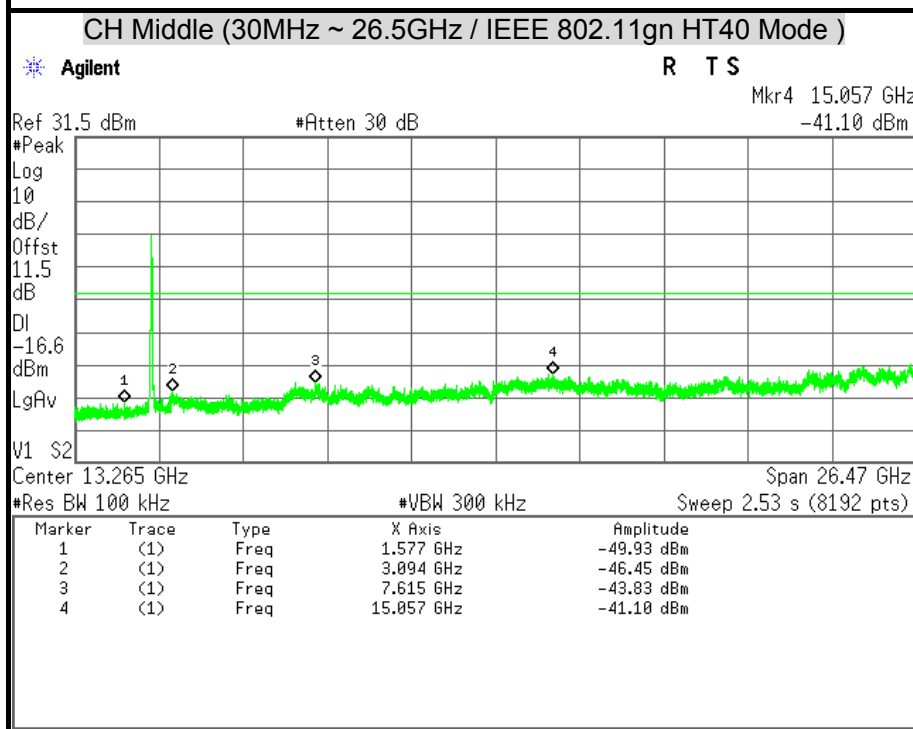
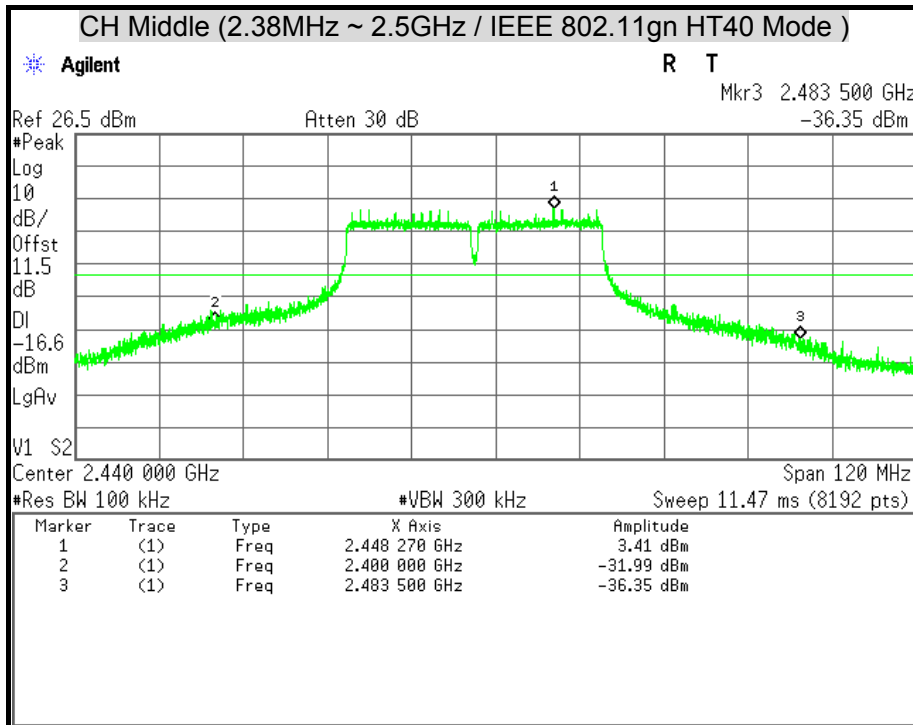

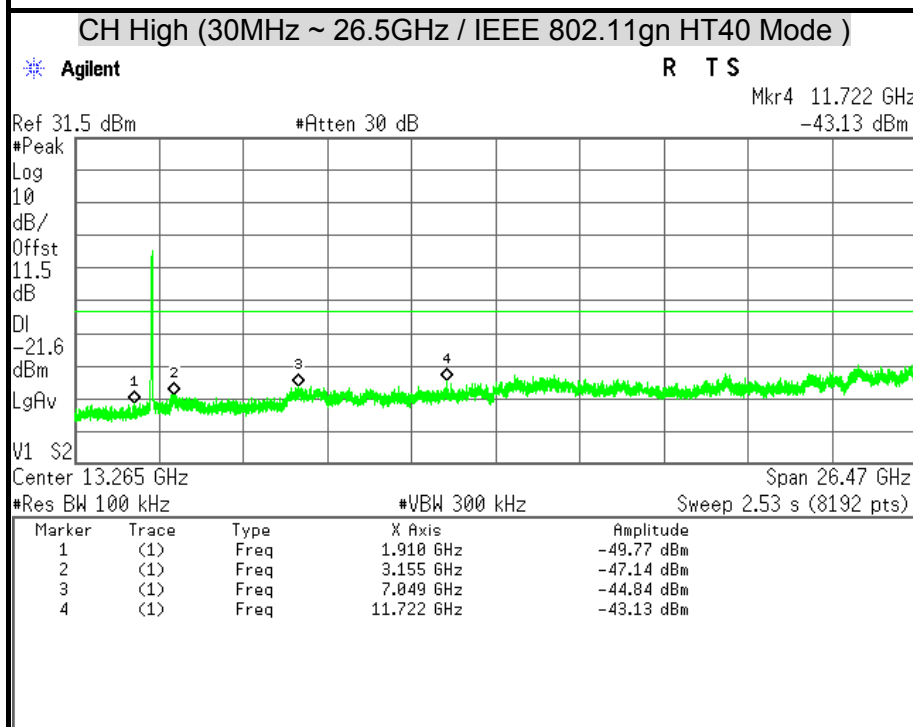
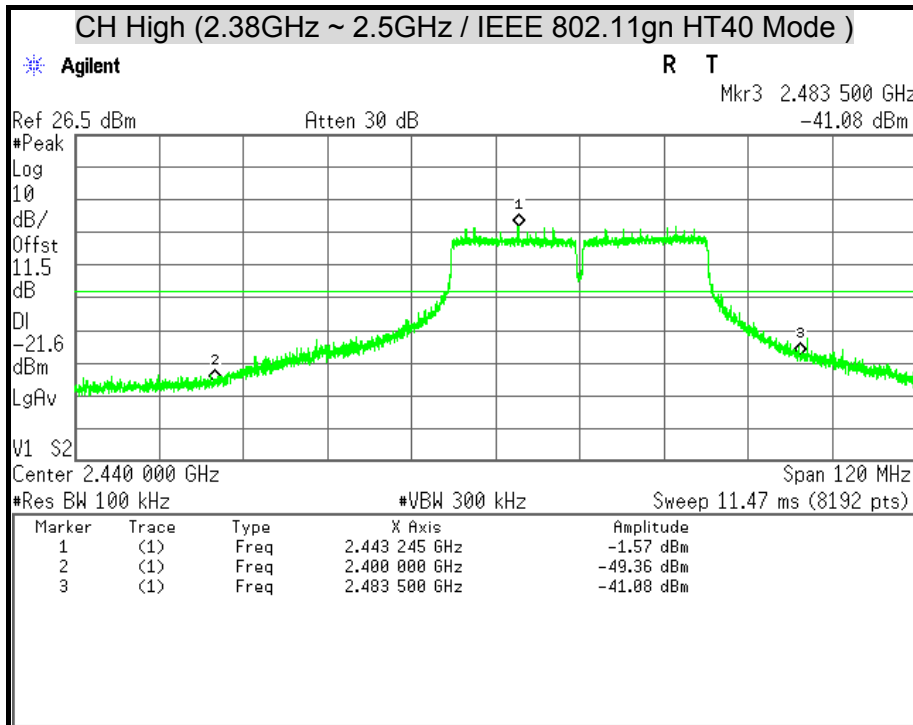

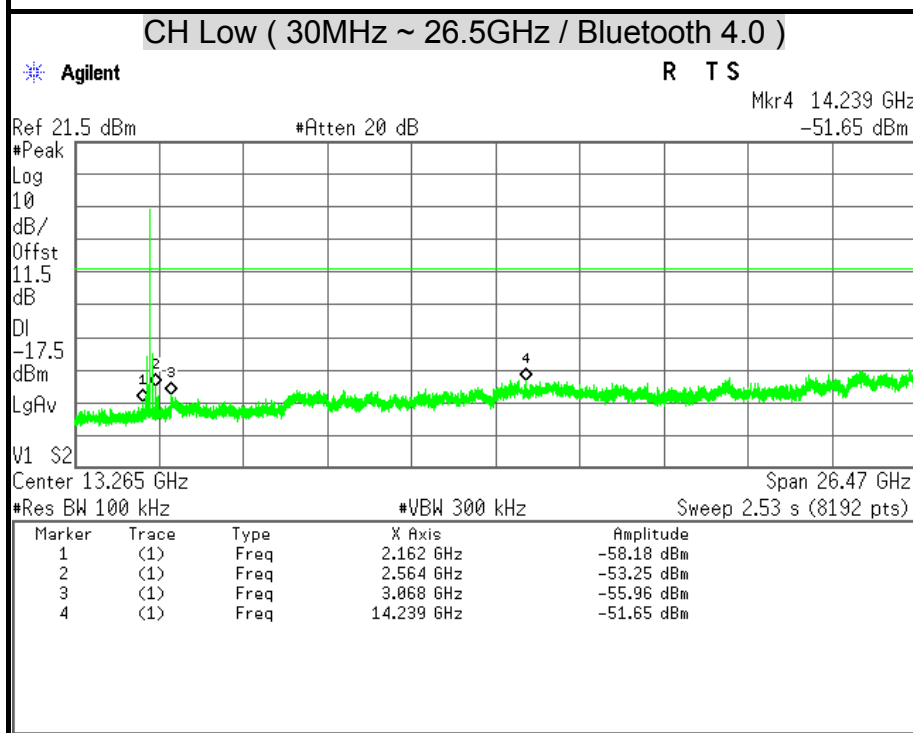
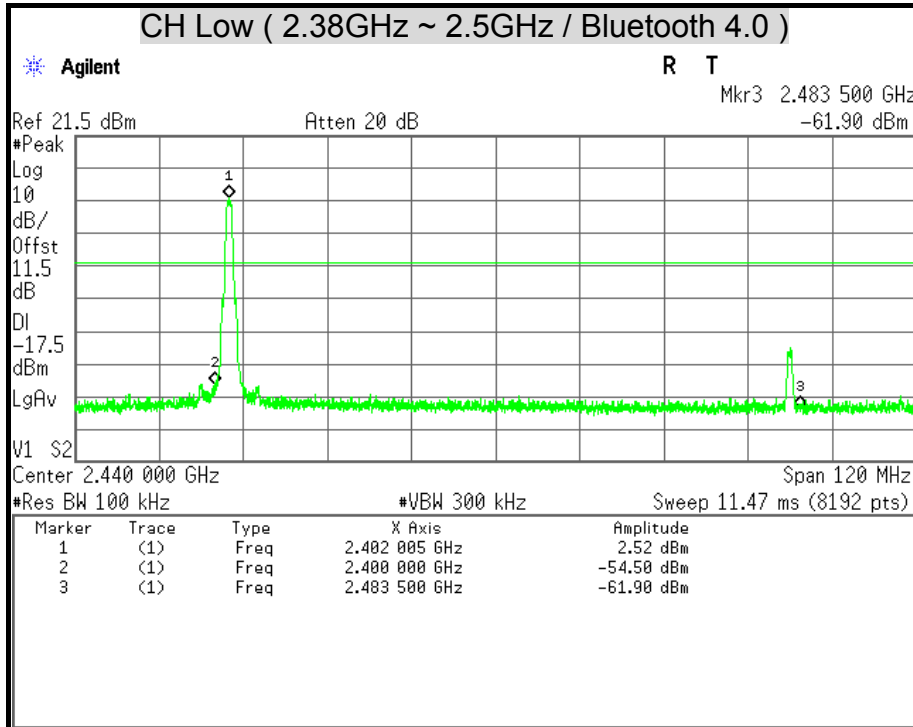

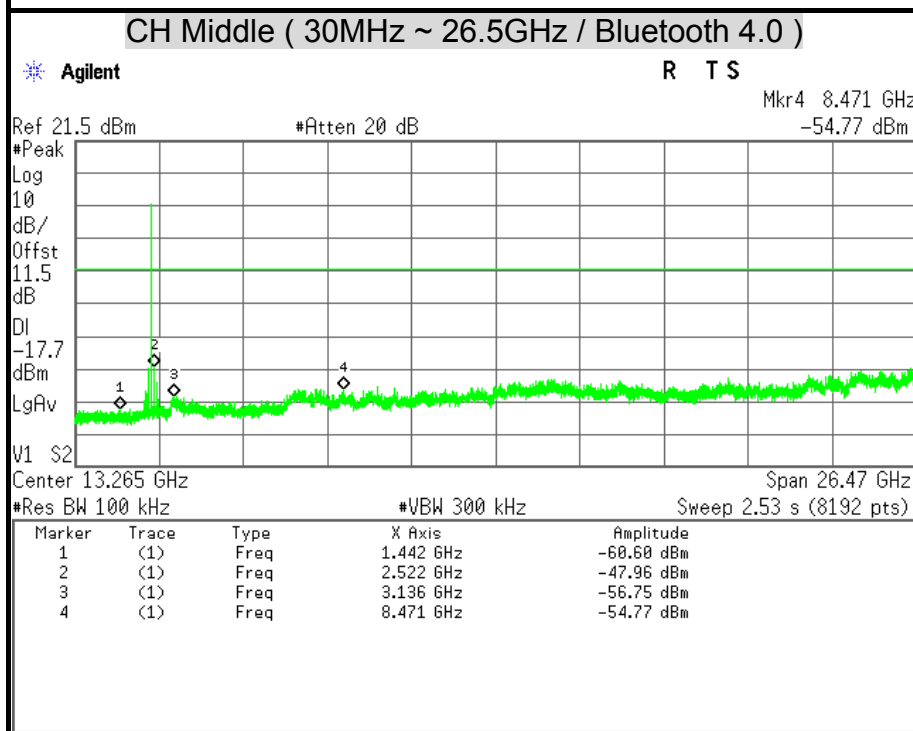
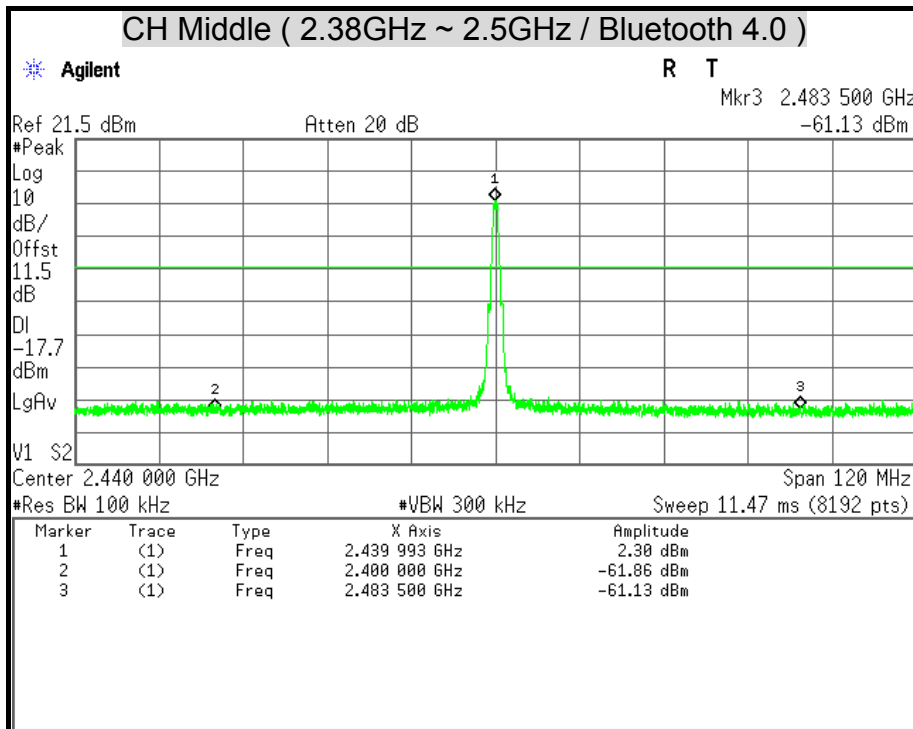

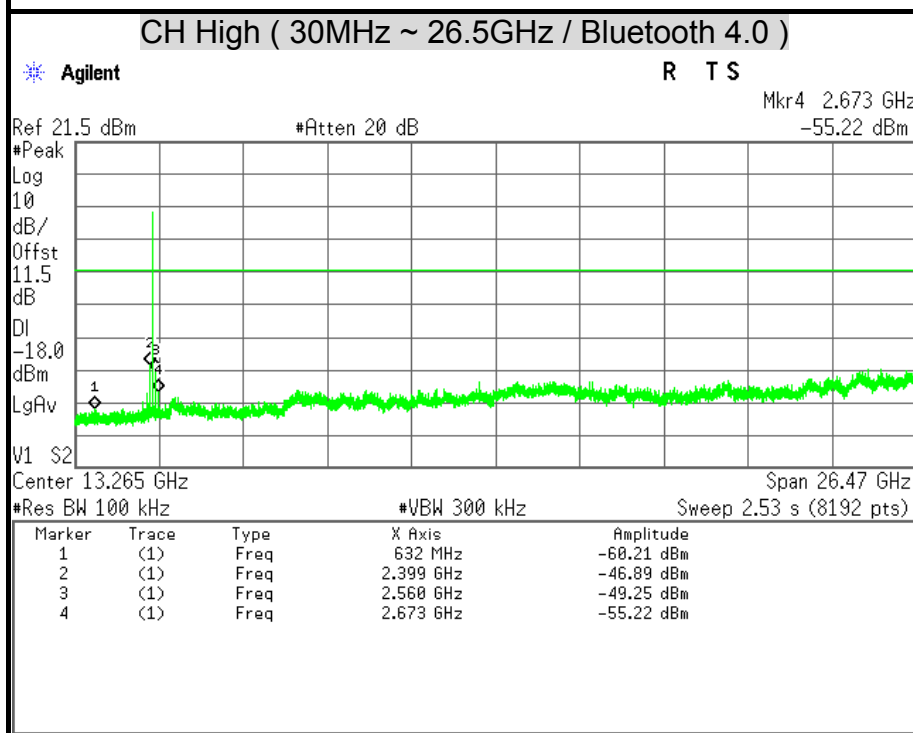
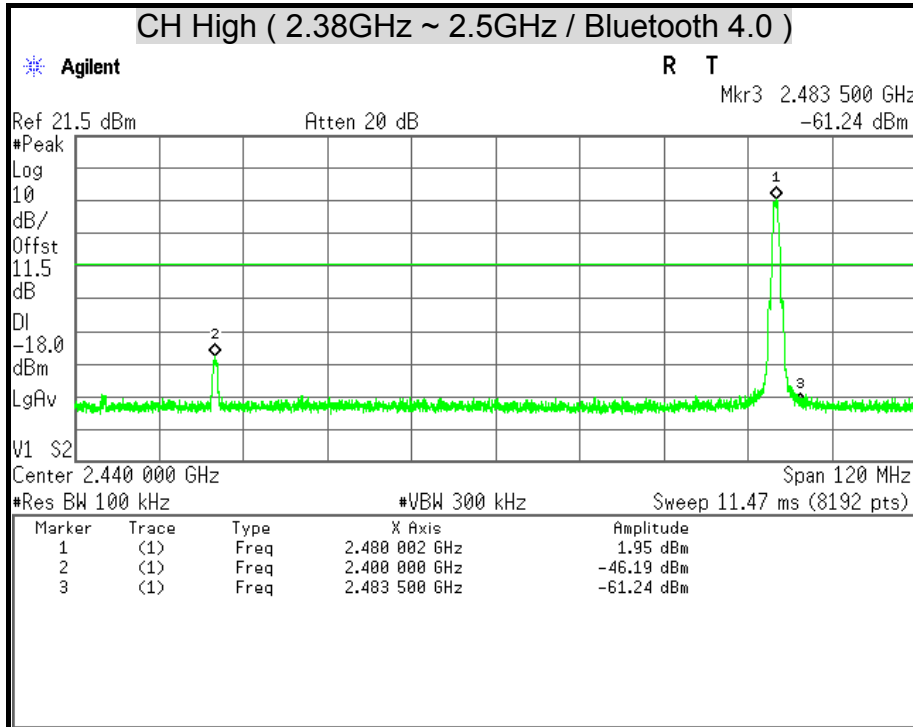



7.6 RADIATED EMISSION

LIMITS

(1) According to § 15.205 (a) Except as shown in paragraph (d) of this section, only spurious emissions are permitted in any of the frequency bands listed below:

MHz	MHz	MHz	GHz
0.090 - 0.110	16.42 - 16.423	399.9 - 410	4.5 - 5.15
¹ 0.495 - 0.505	16.69475 - 16.69525	608 - 614	5.35 - 5.46
2.1735 - 2.1905	16.80425 - 16.80475	960 - 1240	7.25 - 7.75
4.125 - 4.128	25.5 - 25.67	1300 - 1427	8.025 - 8.5
4.17725 - 4.17775	37.5 - 38.25	1435 - 1626.5	9.0 - 9.2
4.20725 - 4.20775	73 - 74.6	1645.5 - 1646.5	9.3 - 9.5
6.215 - 6.218	74.8 - 75.2	1660 - 1710	10.6 - 12.7
6.26775 - 6.26825	108 - 121.94	1718.8 - 1722.2	13.25 - 13.4
6.31175 - 6.31225	123 - 138	2200 - 2300	14.47 - 14.5
8.291 - 8.294	149.9 - 150.05	2310 - 2390	15.35 - 16.2
8.362 - 8.366	156.52475 - 156.52525	2483.5 - 2500	17.7 - 21.4
8.37625 - 8.38675	156.7 - 156.9	2655 - 2900	22.01 - 23.12
8.41425 - 8.41475	162.0125 - 167.17	3260 - 3267	23.6 - 24.0
12.29 - 12.293	167.72 - 173.2	3332 - 3339	31.2 - 31.8
12.51975 - 12.52025	240 - 285	3345.8 - 3338	36.43 - 36.5
12.57675 - 12.57725	322 - 335.4	3600 - 4400	(²)
13.36 - 13.41			

Remark:

- 1. ¹ Until February 1, 1999, this restricted band shall be 0.490-0.510 MHz.
- 2. ² Above 38.6

(2) According to § 15.205 (b) Except as provided in paragraphs (d) and (e), the field strength of emissions appearing within these frequency bands shall not exceed the limits shown in Section 15.209. At frequencies equal to or less than 1000 MHz, compliance with the limits in Section 15.209 shall be demonstrated using measurement instrumentation employing a CISPR quasi-peak detector. Above 1000 MHz, compliance with the emission limits in Section 15.209 shall be demonstrated based on the average value of the measured emissions. The provisions in Section 15.35 apply to these measurements.



(3) According to § 15.209 (a) Except as provided elsewhere in this Subpart, the emissions from an intentional radiator shall not exceed the field strength levels specified in the following table :

Frequency (MHz)	Field Strength (microvolts/meter)	Measurement Distance (meters)
0.009 – 0.490	2400/F(KHz)	300
0.490 – 1.705	24000/F(KHz)	30
1.705 – 30.0	30	30
30 - 88	100 **	3
88 - 216	150 **	3
216 - 960	200 **	3
Above 960	500	3

Remark: **Except as provided in paragraph (g), fundamental emissions from intentional radiators operating under this Section shall not be located in the frequency bands 54-72 MHz, 76-88 MHz, 174-216 MHz or 470-806 MHz. However, operation within these frequency bands is permitted under other sections of this Part, e.g., Sections 15.231 and 15.241.

(4) According to § 15.209 (b) In the emission table above, the tighter limit applies at the band edges.

TEST EQUIPMENT

Radiated Emission / 966Chamber_B

Name of Equipment	Manufacture	Model	Serial Number	Calibration Due
Spectrum Analyzer	Agilent	E4446A	MY46180323	04/15/2015
EMI Test Receiver	ROHDE & SCHWARZ	ESCS 30	835418/008	10/14/2015
Bi-log Antenna	SCHWARZBECK	VULB 9168	9168-250	08/21/2015
Broad-Band Horn Antenna	SCHWARZBECK	BBHA 9120 D	9120D-778	08/19/2015
Double-Ridged Waveguide Horn	ETS-LINDGREN	3117	00078733	12/05/2014
Horn Antenna	COM-POWER	AH-840	03077	12/18/2014
Pre-Amplifier	Agilent	8447D	2944A10052	07/15/2015
Pre-Amplifier	Agilent	8449B	3008A01916	07/15/2015
LOOP Antenna	EMCO	6502	8905-2356	09/23/2015
Notch Filters Band Reject	Micro-Tronics	BRM05702-01	026	N.C.R

Remark: 1. Each piece of equipment is scheduled for calibration once a year.
2. N.C.R = No Calibration Request.



TEST SETUP

The diagram below shows the test setup that is utilized to make the measurements for emission below 1GHz.

9kHz ~ 30MHz

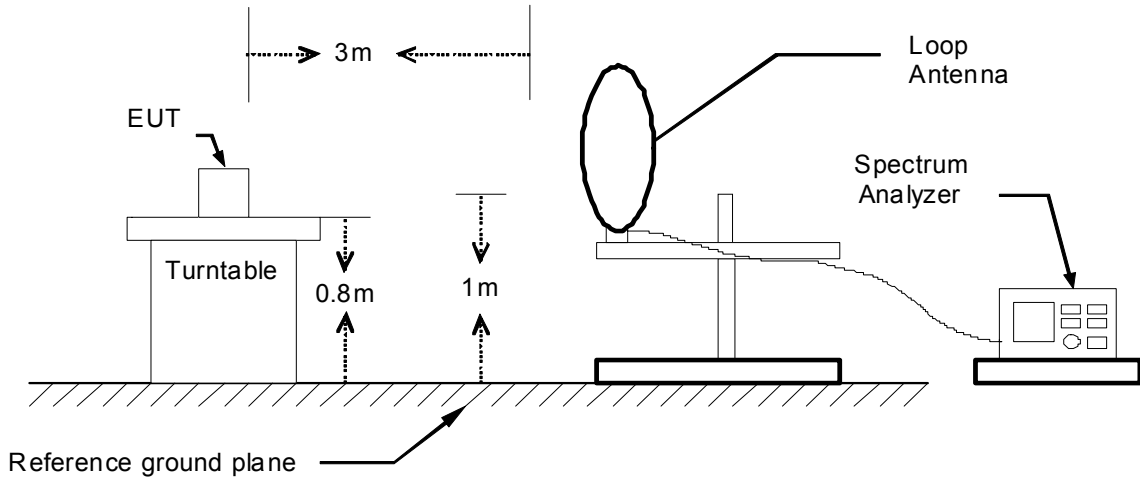

30MHz ~ 1GHz

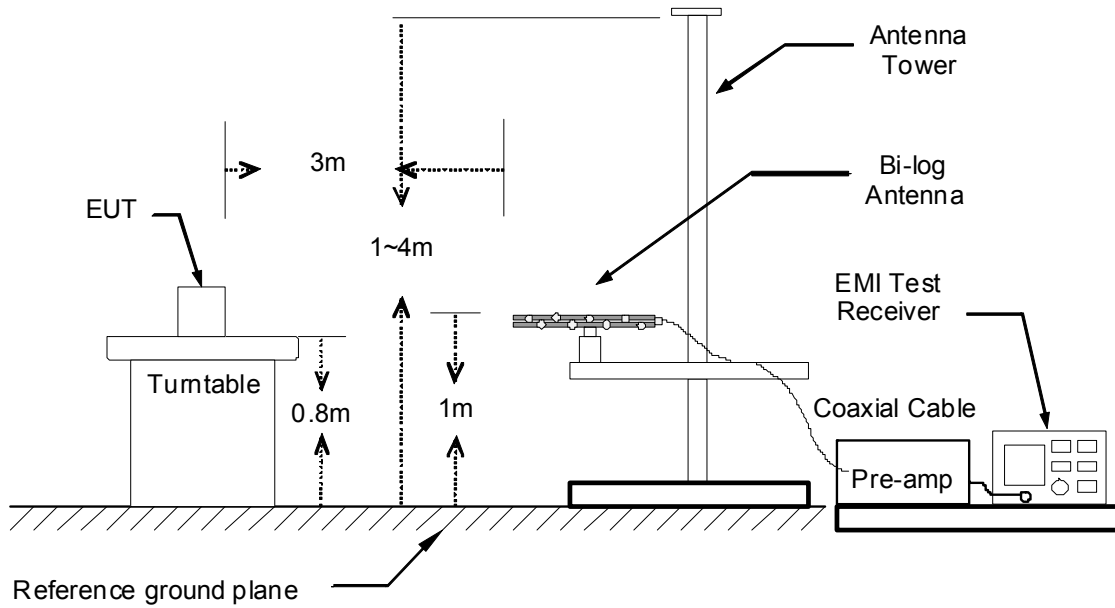



The diagram below shows the test setup that is utilized to make the measurements for emission above 1GHz.

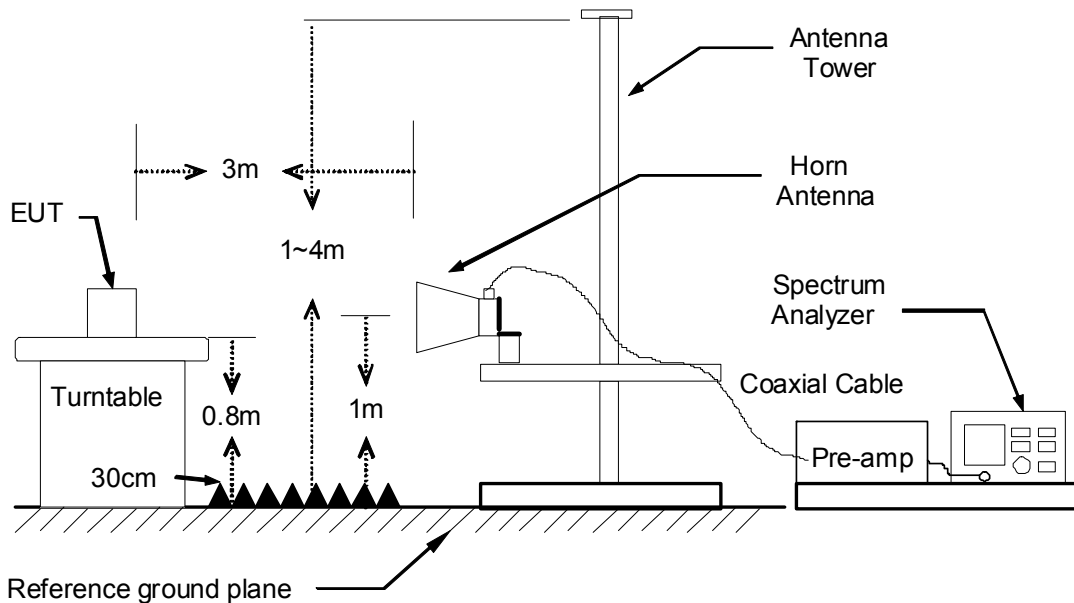

TEST PROCEDURE

1. The EUT was placed on the top of a rotating table 0.8 meters above the ground. The table was rotated 360 degrees to determine the position of the highest radiation.
2. While measuring the radiated emission below 1GHz, the EUT was set 3 meters away from the interference-receiving antenna, which was mounted on the top of a variable-height antenna tower. While measuring the radiated emission above 1GHz, the EUT was set 3 meters away from the interference-receiving antenna.
3. The antenna is a broadband antenna, and its height is varied from one meter to four meters above the ground to determine the maximum value of the field strength. Both horizontal and vertical polarization of the antenna are set to make the measurement.
4. For each suspected emission, the EUT was arranged to its worst case and then the antenna was tuned to heights from 1 meter to 4 meters and the table was turned from 0 degrees to 360 degrees to find the maximum reading.
5. The test-receiver system was set to Peak Detect Function and Specified Bandwidth with Maximum Hold Mode.
6. If the emission level of the EUT in peak mode was 10 dB lower than the limit specified, then testing could be stopped and the peak values of the EUT would be reported. Otherwise the emissions that did not have 10 dB margin would be re-tested one by one using peak, quasi-peak or average method as specified and then reported in a data sheet.

Remark :

1. The resolution bandwidth and video bandwidth of test receiver/spectrum analyzer is 120 KHz for Peak detection (PK) and Quasi-peak detection (QP) at frequency below 1GHz.
2. The resolution bandwidth and video bandwidth of test receiver/spectrum analyzer is 1 MHz for Peak detection and frequency above 1GHz.
3. The resolution bandwidth of test receiver/spectrum analyzer is 1 MHz and the video bandwidth is 10 Hz for Average detection (AV) at frequency above 1GHz.



TEST RESULTS

Below 1 GHz (9kHz ~ 30MHz)

No emission found between lowest internal used/generated frequency to 30MHz.

Below 1 GHz (30MHz ~ 1GHz)

Product Name	Computer	Test By	Waternil Guan
Test Model	TREK-572	Test Date	2014/10/30
Test Mode	TX Mode	Temp. & Humidity	27°C, 54%

966 Chamber_B at 3Meter / Horizontal						
Frequency (MHz)	Reading (dBµV)	Correction Factor (dB/m)	Result (dBµV/m)	Limit (dBµV/m)	Margin (dB)	Remark
70.74	42.98	-16.53	26.45	40.00	-13.55	Peak
106.63	43.67	-17.79	25.88	43.50	-17.62	Peak
159.01	37.00	-13.43	23.58	43.50	-19.92	Peak
250.19	39.97	-13.71	26.26	46.00	-19.74	Peak
389.87	39.55	-10.12	29.43	46.00	-16.57	Peak
474.26	37.36	-8.53	28.83	46.00	-17.17	Peak
685.72	33.90	-5.02	28.88	46.00	-17.12	Peak
833.16	38.06	-2.45	35.62	46.00	-10.38	Peak

966 Chamber_B at 3Meter / Vertical						
Frequency (MHz)	Reading (dBµV)	Correction Factor (dB/m)	Result (dBµV/m)	Limit (dBµV/m)	Margin (dB)	Remark
34.85	51.66	-15.08	36.58	40.00	-3.42	Peak
73.65	49.47	-17.20	32.27	40.00	-7.73	Peak
106.63	44.14	-17.79	26.35	43.50	-17.15	Peak
151.25	32.96	-13.63	19.32	43.50	-24.18	Peak
250.19	36.67	-13.71	22.96	46.00	-23.04	Peak
277.35	36.14	-12.47	23.68	46.00	-22.32	Peak
396.66	35.58	-9.99	25.59	46.00	-20.41	Peak
837.04	33.99	-2.37	31.62	46.00	-14.38	Peak

Remark:

1. Quasi-peak test would be performed if the peak result were greater than the quasi-peak limit.
2. Data of measurement within this frequency range shown " --- " in the table above means the reading of emissions are attenuated more than 20dB below the permissible limits or the field strength is too small to be measured.
3. Correction Factor (dB/m) = Antenna Factor (dB/m) + Cable Loss (dB) – PreAmp.Gain (dB)
4. Result (dBµV/m) = Reading (dBµV) + Correction Factor (dB/m)
5. Margin (dB) = Remark result (dBµV/m) - Quasi-peak limit (dBµV/m).



Above 1 GHz

Product Name	Computer	Test By	Davis Tseng
Test Model	TREK-572	Test Date	2014/10/29
Test Mode	IEEE 802.11b TX / CH Low	Temp. & Humidity	25°C, 55%

966 Chamber_B at 3Meter / Horizontal									
Frequency (MHz)	Reading-PK (dBuV)	Reading-AV (dBuV)	Correction Factor (dB/m)	Result-PK (dBuV/m)	Result-AV (dBuV/m)	Limit-PK (dBuV/m)	Limit-AV (dBuV/m)	Margin (dB)	Remark
1782.00	48.43	---	-0.24	48.20	---	74.00	54.00	-5.80	Peak
2330.00	49.42	---	2.47	51.90	---	74.00	54.00	-2.10	Peak
2484.00	48.73	---	2.78	51.51	---	74.00	54.00	-2.49	Peak
4875.00	39.31	---	8.18	47.50	---	74.00	54.00	-6.50	Peak
6315.00	38.13	---	11.73	49.86	---	74.00	54.00	-4.14	Peak
7260.00	37.37	---	12.94	50.30	---	74.00	54.00	-3.70	Peak

966 Chamber_B at 3Meter / Vertical									
Frequency (MHz)	Reading-PK (dBuV)	Reading-AV (dBuV)	Correction Factor (dB/m)	Result-PK (dBuV/m)	Result-AV (dBuV/m)	Limit-PK (dBuV/m)	Limit-AV (dBuV/m)	Margin (dB)	Remark
1852.00	48.35	---	0.42	48.77	---	74.00	54.00	-5.23	Peak
2186.00	47.39	---	2.19	49.58	---	74.00	54.00	-4.42	Peak
2490.00	47.77	---	2.79	50.56	---	74.00	54.00	-3.44	Peak
4830.00	38.29	---	8.09	46.38	---	74.00	54.00	-7.62	Peak
5250.00	40.55	---	8.87	49.42	---	74.00	54.00	-4.58	Peak
6270.00	38.56	---	11.59	50.15	---	74.00	54.00	-3.85	Peak

Remark:

1. Measuring frequencies from 1 GHz to the 10th harmonic of highest fundamental frequency.
2. Average test would be performed if the peak result were greater than the average limit.
3. Data of measurement within this frequency range shown " --- " in the table above means the reading of emissions are attenuated more than 20dB below the permissible limits or the field strength is too small to be measured.
4. Measurements above show only up to 6 maximum emissions noted, or would be lesser, with " N/A " remark, if no specific emissions from the EUT are recorded (ie: margin>20dB from the applicable limit) and considered that's already beyond the background noise floor.
5. Result = Reading + Correction Factor
Margin = Result - Limit
Remark Peak = Result(PK) - Limit(AV)
Remark AVG = Result(AV) - Limit(AV)



Product Name	Computer	Test By	Davis Tseng
Test Model	TREK-572	Test Date	2014/10/29
Test Mode	IEEE 802.11b TX / CH Middle	Temp. & Humidity	25°C, 55%

966 Chamber_B at 3Meter / Horizontal									
Frequency (MHz)	Reading-PK (dBuV)	Reading-AV (dBuV)	Correction Factor (dB/m)	Result-PK (dBuV/m)	Result-AV (dBuV/m)	Limit-PK (dBuV/m)	Limit-AV (dBuV/m)	Margin (dB)	Remark
1850.00	48.21	---	0.40	48.61	---	74.00	54.00	-5.39	Peak
2390.00	49.09	---	2.59	51.69	---	74.00	54.00	-2.31	Peak
2484.00	50.01	---	2.78	52.79	---	74.00	54.00	-1.21	Peak
4875.00	39.79	---	8.18	47.98	---	74.00	54.00	-6.02	Peak
5775.00	38.83	---	10.13	48.96	---	74.00	54.00	-5.04	Peak
6420.00	38.37	---	12.03	50.41	---	74.00	54.00	-3.59	Peak

966 Chamber_B at 3Meter / Vertical									
Frequency (MHz)	Reading-PK (dBuV)	Reading-AV (dBuV)	Correction Factor (dB/m)	Result-PK (dBuV/m)	Result-AV (dBuV/m)	Limit-PK (dBuV/m)	Limit-AV (dBuV/m)	Margin (dB)	Remark
1976.00	47.95	---	1.59	49.55	---	74.00	54.00	-4.45	Peak
2390.00	46.52	---	2.59	49.11	---	74.00	54.00	-4.89	Peak
2484.00	50.44	---	2.78	53.22	---	74.00	54.00	-0.78	Peak
3915.00	41.74	---	5.63	47.36	---	74.00	54.00	-6.64	Peak
4920.00	38.51	---	8.28	46.78	---	74.00	54.00	-7.22	Peak
5475.00	38.83	---	9.27	48.10	---	74.00	54.00	-5.90	Peak

Remark:

1. Measuring frequencies from 1 GHz to the 10th harmonic of highest fundamental frequency.
2. Average test would be performed if the peak result were greater than the average limit.
3. Data of measurement within this frequency range shown " --- " in the table above means the reading of emissions are attenuated more than 20dB below the permissible limits or the field strength is too small to be measured.
4. Measurements above show only up to 6 maximum emissions noted, or would be lesser, with " N/A " remark, if no specific emissions from the EUT are recorded (ie: margin>20dB from the applicable limit) and considered that's already beyond the background noise floor.
5. Result = Reading + Correction Factor
 Margin = Result - Limit
 Remark Peak = Result(PK) - Limit(AV)
 Remark AVG = Result(AV) - Limit(AV)



Product Name	Computer	Test By	Davis Tseng
Test Model	TREK-572	Test Date	2014/10/29
Test Mode	IEEE 802.11b TX / CH High	Temp. & Humidity	25°C, 55%

966 Chamber_B at 3Meter / Horizontal									
Frequency (MHz)	Reading-PK (dBuV)	Reading-AV (dBuV)	Correction Factor (dB/m)	Result-PK (dBuV/m)	Result-AV (dBuV/m)	Limit-PK (dBuV/m)	Limit-AV (dBuV/m)	Margin (dB)	Remark
1314.00	49.69	---	-2.89	46.80	---	74.00	54.00	-7.20	Peak
1976.00	49.13	---	1.59	50.73	---	74.00	54.00	-3.27	Peak
2334.00	48.61	---	2.48	51.09	---	74.00	54.00	-2.91	Peak
4860.00	39.14	---	8.15	47.29	---	74.00	54.00	-6.71	Peak
6270.00	38.72	---	11.59	50.31	---	74.00	54.00	-3.69	Peak
7305.00	38.94	---	13.08	52.01	---	74.00	54.00	-1.99	Peak

966 Chamber_B at 3Meter / Vertical									
Frequency (MHz)	Reading-PK (dBuV)	Reading-AV (dBuV)	Correction Factor (dB/m)	Result-PK (dBuV/m)	Result-AV (dBuV/m)	Limit-PK (dBuV/m)	Limit-AV (dBuV/m)	Margin (dB)	Remark
1858.00	47.82	---	0.48	48.30	---	74.00	54.00	-5.70	Peak
2010.00	49.08	---	1.84	50.92	---	74.00	54.00	-3.08	Peak
2370.00	47.58	---	2.55	50.13	---	74.00	54.00	-3.87	Peak
3225.00	41.68	---	4.26	45.94	---	74.00	54.00	-8.06	Peak
4830.00	39.51	---	8.09	47.60	---	74.00	54.00	-6.40	Peak
6360.00	38.87	---	11.86	50.73	---	74.00	54.00	-3.27	Peak

Remark:

1. Measuring frequencies from 1 GHz to the 10th harmonic of highest fundamental frequency.
2. Average test would be performed if the peak result were greater than the average limit.
3. Data of measurement within this frequency range shown " --- " in the table above means the reading of emissions are attenuated more than 20dB below the permissible limits or the field strength is too small to be measured.
4. Measurements above show only up to 6 maximum emissions noted, or would be lesser, with " N/A " remark, if no specific emissions from the EUT are recorded (ie: margin>20dB from the applicable limit) and considered that's already beyond the background noise floor.
5. Result = Reading + Correction Factor
Margin = Result - Limit
Remark Peak = Result(PK) - Limit(AV)
Remark AVG = Result(AV) - Limit(AV)



Product Name	Computer	Test By	Davis Tseng
Test Model	TREK-572	Test Date	2014/10/29
Test Mode	IEEE 802.11g TX / CH Low	Temp. & Humidity	25°C, 55%

966 Chamber_B at 3Meter / Horizontal									
Frequency (MHz)	Reading-PK (dBuV)	Reading-AV (dBuV)	Correction Factor (dB/m)	Result-PK (dBuV/m)	Result-AV (dBuV/m)	Limit-PK (dBuV/m)	Limit-AV (dBuV/m)	Margin (dB)	Remark
1962.00	48.46	---	1.46	49.92	---	74.00	54.00	-4.08	Peak
2230.00	48.08	---	2.28	50.35	---	74.00	54.00	-3.65	Peak
2498.00	48.27	---	2.81	51.08	---	74.00	54.00	-2.92	Peak
3840.00	41.20	---	5.42	46.62	---	74.00	54.00	-7.38	Peak
4755.00	39.70	---	7.94	47.63	---	74.00	54.00	-6.37	Peak
6435.00	37.89	---	12.08	49.97	---	74.00	54.00	-4.03	Peak

966 Chamber_B at 3Meter / Vertical									
Frequency (MHz)	Reading-PK (dBuV)	Reading-AV (dBuV)	Correction Factor (dB/m)	Result-PK (dBuV/m)	Result-AV (dBuV/m)	Limit-PK (dBuV/m)	Limit-AV (dBuV/m)	Margin (dB)	Remark
1822.00	49.11	---	0.14	49.25	---	74.00	54.00	-4.75	Peak
2056.00	48.65	---	1.93	50.58	---	74.00	54.00	-3.42	Peak
2496.00	47.35	---	2.80	50.15	---	74.00	54.00	-3.85	Peak
4815.00	39.13	---	8.06	47.19	---	74.00	54.00	-6.81	Peak
5160.00	38.54	---	8.72	47.26	---	74.00	54.00	-6.74	Peak
6240.00	38.46	---	11.51	49.97	---	74.00	54.00	-4.03	Peak

Remark:

1. Measuring frequencies from 1 GHz to the 10th harmonic of highest fundamental frequency.
2. Average test would be performed if the peak result were greater than the average limit.
3. Data of measurement within this frequency range shown " --- " in the table above means the reading of emissions are attenuated more than 20dB below the permissible limits or the field strength is too small to be measured.
4. Measurements above show only up to 6 maximum emissions noted, or would be lesser, with " N/A " remark, if no specific emissions from the EUT are recorded (ie: margin>20dB from the applicable limit) and considered that's already beyond the background noise floor.
5. Result = Reading + Correction Factor
Margin = Result - Limit
Remark Peak = Result(PK) - Limit(AV)
Remark AVG = Result(AV) - Limit(AV)



Product Name	Computer	Test By	Davis Tseng
Test Model	TREK-572	Test Date	2014/10/29
Test Mode	IEEE 802.11g TX / CH Middle	Temp. & Humidity	25°C, 55%

966 Chamber_B at 3Meter / Horizontal									
Frequency (MHz)	Reading-PK (dBuV)	Reading-AV (dBuV)	Correction Factor (dB/m)	Result-PK (dBuV/m)	Result-AV (dBuV/m)	Limit-PK (dBuV/m)	Limit-AV (dBuV/m)	Margin (dB)	Remark
1654.00	49.22	---	-1.45	47.77	---	74.00	54.00	-6.23	Peak
2390.00	63.20	47.36	2.59	65.79	49.95	74.00	54.00	-4.05	AVG
2484.00	59.11	42.31	2.78	61.89	45.09	74.00	54.00	-8.91	AVG
4740.00	39.33	---	7.90	47.24	---	74.00	54.00	-6.76	Peak
5535.00	38.83	---	9.41	48.24	---	74.00	54.00	-5.76	Peak
6420.00	37.96	---	12.03	49.99	---	74.00	54.00	-4.01	Peak

966 Chamber_B at 3Meter / Vertical									
Frequency (MHz)	Reading-PK (dBuV)	Reading-AV (dBuV)	Correction Factor (dB/m)	Result-PK (dBuV/m)	Result-AV (dBuV/m)	Limit-PK (dBuV/m)	Limit-AV (dBuV/m)	Margin (dB)	Remark
1630.00	49.17	---	-1.67	47.49	---	74.00	54.00	-6.51	Peak
2390.00	58.92	42.46	2.59	61.51	45.05	74.00	54.00	-8.95	AVG
2484.00	51.06	40.36	2.78	53.84	43.14	74.00	54.00	-10.86	AVG
3645.00	41.84	---	4.89	46.73	---	74.00	54.00	-7.27	Peak
4860.00	39.18	---	8.15	47.33	---	74.00	54.00	-6.67	Peak
5520.00	38.90	---	9.37	48.27	---	74.00	54.00	-5.73	Peak

Remark:

1. Measuring frequencies from 1 GHz to the 10th harmonic of highest fundamental frequency.
2. Average test would be performed if the peak result were greater than the average limit.
3. Data of measurement within this frequency range shown " --- " in the table above means the reading of emissions are attenuated more than 20dB below the permissible limits or the field strength is too small to be measured.
4. Measurements above show only up to 6 maximum emissions noted, or would be lesser, with " N/A " remark, if no specific emissions from the EUT are recorded (ie: margin>20dB from the applicable limit) and considered that's already beyond the background noise floor.
5. Result = Reading + Correction Factor
Margin = Result - Limit
Remark Peak = Result(PK) - Limit(AV)
Remark AVG = Result(AV) - Limit(AV)



Product Name	Computer	Test By	Davis Tseng
Test Model	TREK-572	Test Date	2014/10/29
Test Mode	IEEE 802.11g TX / CH High	Temp. & Humidity	25°C, 55%

966 Chamber_B at 3Meter / Horizontal									
Frequency (MHz)	Reading-PK (dBuV)	Reading-AV (dBuV)	Correction Factor (dB/m)	Result-PK (dBuV/m)	Result-AV (dBuV/m)	Limit-PK (dBuV/m)	Limit-AV (dBuV/m)	Margin (dB)	Remark
1788.00	48.63	---	-0.18	48.45	---	74.00	54.00	-5.55	Peak
2262.00	48.87	---	2.34	51.21	---	74.00	54.00	-2.79	Peak
2380.00	48.88	---	2.57	51.45	---	74.00	54.00	-2.55	Peak
4920.00	39.30	---	8.28	47.57	---	74.00	54.00	-6.43	Peak
6510.00	38.34	---	12.27	50.61	---	74.00	54.00	-3.39	Peak
7275.00	38.84	---	12.98	51.82	---	74.00	54.00	-2.18	Peak
966 Chamber_B at 3Meter / Vertical									
Frequency (MHz)	Reading-PK (dBuV)	Reading-AV (dBuV)	Correction Factor (dB/m)	Result-PK (dBuV/m)	Result-AV (dBuV/m)	Limit-PK (dBuV/m)	Limit-AV (dBuV/m)	Margin (dB)	Remark
1948.00	48.23	---	1.33	49.56	---	74.00	54.00	-4.44	Peak
2096.00	48.42	---	2.01	50.43	---	74.00	54.00	-3.57	Peak
2370.00	47.75	---	2.55	50.31	---	74.00	54.00	-3.69	Peak
4215.00	40.63	---	6.53	47.16	---	74.00	54.00	-6.84	Peak
4980.00	39.73	---	8.40	48.13	---	74.00	54.00	-5.87	Peak
7155.00	39.15	---	12.61	51.76	---	74.00	54.00	-2.24	Peak

Remark:

1. Measuring frequencies from 1 GHz to the 10th harmonic of highest fundamental frequency.
2. Average test would be performed if the peak result were greater than the average limit.
3. Data of measurement within this frequency range shown " --- " in the table above means the reading of emissions are attenuated more than 20dB below the permissible limits or the field strength is too small to be measured.
4. Measurements above show only up to 6 maximum emissions noted, or would be lesser, with " N/A " remark, if no specific emissions from the EUT are recorded (ie: margin>20dB from the applicable limit) and considered that's already beyond the background noise floor.
5. Result = Reading + Correction Factor
Margin = Result - Limit
Remark Peak = Result(PK) - Limit(AV)
Remark AVG = Result(AV) - Limit(AV)



Product Name	Computer	Test By	Davis Tseng
Test Model	TREK-572	Test Date	2014/10/29
Test Mode	IEEE 802.11gn HT20 TX / CH Low	Temp. & Humidity	25°C, 55%

966 Chamber_B at 3Meter / Horizontal

Frequency (MHz)	Reading-PK (dBuV)	Reading-AV (dBuV)	Correction Factor (dB/m)	Result-PK (dBuV/m)	Result-AV (dBuV/m)	Limit-PK (dBuV/m)	Limit-AV (dBuV/m)	Margin (dB)	Remark
1838.00	48.49	---	0.29	48.79	---	74.00	54.00	-5.21	Peak
2040.00	49.05	---	1.90	50.95	---	74.00	54.00	-3.05	Peak
2484.00	48.54	---	2.78	51.32	---	74.00	54.00	-2.68	Peak
4830.00	38.37	---	8.09	46.46	---	74.00	54.00	-7.54	Peak
5115.00	39.31	---	8.64	47.95	---	74.00	54.00	-6.05	Peak
6690.00	37.73	---	12.22	49.95	---	74.00	54.00	-4.05	Peak

966 Chamber_B at 3Meter / Vertical

Frequency (MHz)	Reading-PK (dBuV)	Reading-AV (dBuV)	Correction Factor (dB/m)	Result-PK (dBuV/m)	Result-AV (dBuV/m)	Limit-PK (dBuV/m)	Limit-AV (dBuV/m)	Margin (dB)	Remark
1962.00	48.10	---	1.46	49.56	---	74.00	54.00	-4.44	Peak
2246.00	47.64	---	2.31	49.95	---	74.00	54.00	-4.05	Peak
2500.00	47.34	---	2.81	50.15	---	74.00	54.00	-3.85	Peak
4815.00	38.98	---	8.06	47.04	---	74.00	54.00	-6.96	Peak
6210.00	38.12	---	11.42	49.54	---	74.00	54.00	-4.46	Peak
7110.00	38.26	---	12.47	50.73	---	74.00	54.00	-3.27	Peak

Remark:

1. Measuring frequencies from 1 GHz to the 10th harmonic of highest fundamental frequency.
2. Average test would be performed if the peak result were greater than the average limit.
3. Data of measurement within this frequency range shown " --- " in the table above means the reading of emissions are attenuated more than 20dB below the permissible limits or the field strength is too small to be measured.
4. Measurements above show only up to 6 maximum emissions noted, or would be lesser, with " N/A " remark, if no specific emissions from the EUT are recorded (ie: margin>20dB from the applicable limit) and considered that's already beyond the background noise floor.
5. Result = Reading + Correction Factor
Margin = Result - Limit
Remark Peak = Result(PK) - Limit(AV)
Remark AVG = Result(AV) - Limit(AV)



Product Name	Computer	Test By	Davis Tseng
Test Model	TREK-572	Test Date	2014/10/29
Test Mode	IEEE 802.11gn HT20 TX / CH Middle	Temp. & Humidity	25°C, 55%

966 Chamber_B at 3Meter / Horizontal									
Frequency (MHz)	Reading-PK (dBuV)	Reading-AV (dBuV)	Correction Factor (dB/m)	Result-PK (dBuV/m)	Result-AV (dBuV/m)	Limit-PK (dBuV/m)	Limit-AV (dBuV/m)	Margin (dB)	Remark
1710.00	49.29	---	-0.92	48.37	---	74.00	54.00	-5.63	Peak
2390.00	62.08	47.34	2.59	64.67	49.93	74.00	54.00	-4.07	AVG
2484.00	60.40	43.38	2.78	63.18	46.16	74.00	54.00	-7.84	AVG
4875.00	38.83	---	8.18	47.02	---	74.00	54.00	-6.98	Peak
5970.00	37.97	---	10.71	48.69	---	74.00	54.00	-5.31	Peak
6795.00	39.44	---	12.19	51.63	---	74.00	54.00	-2.37	Peak

966 Chamber_B at 3Meter / Vertical									
Frequency (MHz)	Reading-PK (dBuV)	Reading-AV (dBuV)	Correction Factor (dB/m)	Result-PK (dBuV/m)	Result-AV (dBuV/m)	Limit-PK (dBuV/m)	Limit-AV (dBuV/m)	Margin (dB)	Remark
1722.00	49.15	---	-0.80	48.35	---	74.00	54.00	-5.65	Peak
2386.00	56.34	41.61	2.58	58.92	44.19	74.00	54.00	-9.81	AVG
2484.00	50.63	---	2.78	53.41	---	74.00	54.00	-0.59	Peak
4860.00	38.57	---	8.15	46.72	---	74.00	54.00	-7.28	Peak
5970.00	38.20	---	10.71	48.91	---	74.00	54.00	-5.09	Peak
7065.00	39.12	---	12.33	51.45	---	74.00	54.00	-2.55	Peak

Remark:

1. Measuring frequencies from 1 GHz to the 10th harmonic of highest fundamental frequency.
2. Average test would be performed if the peak result were greater than the average limit.
3. Data of measurement within this frequency range shown " --- " in the table above means the reading of emissions are attenuated more than 20dB below the permissible limits or the field strength is too small to be measured.
4. Measurements above show only up to 6 maximum emissions noted, or would be lesser, with " N/A " remark, if no specific emissions from the EUT are recorded (ie: margin>20dB from the applicable limit) and considered that's already beyond the background noise floor.
5. Result = Reading + Correction Factor
Margin = Result - Limit
Remark Peak = Result(PK) - Limit(AV)
Remark AVG = Result(AV) - Limit(AV)



Product Name	Computer	Test By	Davis Tseng
Test Model	TREK-572	Test Date	2014/10/29
Test Mode	IEEE 802.11gn HT20 TX / CH High	Temp. & Humidity	25°C, 55%

966 Chamber_B at 3Meter / Horizontal									
Frequency (MHz)	Reading-PK (dBuV)	Reading-AV (dBuV)	Correction Factor (dB/m)	Result-PK (dBuV/m)	Result-AV (dBuV/m)	Limit-PK (dBuV/m)	Limit-AV (dBuV/m)	Margin (dB)	Remark
1262.00	50.01	---	-2.89	47.12	---	74.00	54.00	-6.88	Peak
2008.00	47.80	---	1.84	49.64	---	74.00	54.00	-4.36	Peak
2334.00	48.77	---	2.48	51.25	---	74.00	54.00	-2.75	Peak
4890.00	38.26	---	8.21	46.47	---	74.00	54.00	-7.53	Peak
5820.00	37.92	---	10.26	48.18	---	74.00	54.00	-5.82	Peak
6705.00	38.73	---	12.21	50.94	---	74.00	54.00	-3.06	Peak

966 Chamber_B at 3Meter / Vertical									
Frequency (MHz)	Reading-PK (dBuV)	Reading-AV (dBuV)	Correction Factor (dB/m)	Result-PK (dBuV/m)	Result-AV (dBuV/m)	Limit-PK (dBuV/m)	Limit-AV (dBuV/m)	Margin (dB)	Remark
1270.00	50.26	---	-2.89	47.37	---	74.00	54.00	-6.63	Peak
2182.00	48.43	---	2.18	50.62	---	74.00	54.00	-3.38	Peak
2366.00	47.93	---	2.54	50.47	---	74.00	54.00	-3.53	Peak
4965.00	38.75	---	8.37	47.12	---	74.00	54.00	-6.88	Peak
5820.00	38.03	---	10.26	48.29	---	74.00	54.00	-5.71	Peak
7245.00	38.87	---	12.89	51.76	---	74.00	54.00	-2.24	Peak

Remark:

1. Measuring frequencies from 1 GHz to the 10th harmonic of highest fundamental frequency.
2. Average test would be performed if the peak result were greater than the average limit.
3. Data of measurement within this frequency range shown " --- " in the table above means the reading of emissions are attenuated more than 20dB below the permissible limits or the field strength is too small to be measured.
4. Measurements above show only up to 6 maximum emissions noted, or would be lesser, with " N/A " remark, if no specific emissions from the EUT are recorded (ie: margin>20dB from the applicable limit) and considered that's already beyond the background noise floor.
5. Result = Reading + Correction Factor
Margin = Result - Limit
Remark Peak = Result(PK) - Limit(AV)
Remark AVG = Result(AV) - Limit(AV)



Product Name	Computer	Test By	Davis Tseng
Test Model	TREK-572	Test Date	2014/10/29
Test Mode	IEEE 802.11gn HT40 TX / CH Low	Temp. & Humidity	25°C, 55%

966 Chamber_B at 3Meter / Horizontal

Frequency (MHz)	Reading-PK (dBuV)	Reading-AV (dBuV)	Correction Factor (dB/m)	Result-PK (dBuV/m)	Result-AV (dBuV/m)	Limit-PK (dBuV/m)	Limit-AV (dBuV/m)	Margin (dB)	Remark
2088.00	47.67	---	1.99	49.67	---	74.00	54.00	-4.33	Peak
2262.00	48.04	---	2.34	50.38	---	74.00	54.00	-3.62	Peak
2484.00	47.88	---	2.78	50.66	---	74.00	54.00	-3.34	Peak
4785.00	39.19	---	8.00	47.19	---	74.00	54.00	-6.81	Peak
6345.00	38.10	---	11.81	49.92	---	74.00	54.00	-4.08	Peak
7260.00	37.41	---	12.94	50.35	---	74.00	54.00	-3.65	Peak

966 Chamber_B at 3Meter / Vertical

Frequency (MHz)	Reading-PK (dBuV)	Reading-AV (dBuV)	Correction Factor (dB/m)	Result-PK (dBuV/m)	Result-AV (dBuV/m)	Limit-PK (dBuV/m)	Limit-AV (dBuV/m)	Margin (dB)	Remark
2100.00	47.61	---	2.02	49.63	---	74.00	54.00	-4.37	Peak
2276.00	47.91	---	2.37	50.28	---	74.00	54.00	-3.72	Peak
2484.00	46.26	---	2.78	49.04	---	74.00	54.00	-4.96	Peak
4770.00	39.36	---	7.97	47.33	---	74.00	54.00	-6.67	Peak
6390.00	38.58	---	11.95	50.52	---	74.00	54.00	-3.48	Peak
7170.00	39.07	---	12.66	51.72	---	74.00	54.00	-2.28	Peak

Remark:

1. Measuring frequencies from 1 GHz to the 10th harmonic of highest fundamental frequency.
2. Average test would be performed if the peak result were greater than the average limit.
3. Data of measurement within this frequency range shown " --- " in the table above means the reading of emissions are attenuated more than 20dB below the permissible limits or the field strength is too small to be measured.
4. Measurements above show only up to 6 maximum emissions noted, or would be lesser, with " N/A " remark, if no specific emissions from the EUT are recorded (ie: margin>20dB from the applicable limit) and considered that's already beyond the background noise floor.
5. Result = Reading + Correction Factor
Margin = Result - Limit
Remark Peak = Result(PK) - Limit(AV)
Remark AVG = Result(AV) - Limit(AV)



Product Name	Computer	Test By	Davis Tseng
Test Model	TREK-572	Test Date	2014/10/29
Test Mode	IEEE 802.11gn HT40 TX / CH Middle	Temp. & Humidity	25°C, 55%

966 Chamber_B at 3Meter / Horizontal									
Frequency (MHz)	Reading-PK (dBuV)	Reading-AV (dBuV)	Correction Factor (dB/m)	Result-PK (dBuV/m)	Result-AV (dBuV/m)	Limit-PK (dBuV/m)	Limit-AV (dBuV/m)	Margin (dB)	Remark
2006.00	47.71	---	1.83	49.55	---	74.00	54.00	-4.45	Peak
2390.00	65.99	51.11	2.59	68.58	53.70	74.00	54.00	-0.30	AVG
2484.00	62.94	48.11	2.78	65.72	50.89	74.00	54.00	-3.11	AVG
4905.00	38.85	---	8.24	47.09	---	74.00	54.00	-6.91	Peak
6360.00	38.45	---	11.86	50.31	---	74.00	54.00	-3.69	Peak
7695.00	37.58	---	13.52	51.10	---	74.00	54.00	-2.90	Peak

966 Chamber_B at 3Meter / Vertical									
Frequency (MHz)	Reading-PK (dBuV)	Reading-AV (dBuV)	Correction Factor (dB/m)	Result-PK (dBuV/m)	Result-AV (dBuV/m)	Limit-PK (dBuV/m)	Limit-AV (dBuV/m)	Margin (dB)	Remark
2048.00	49.34	---	1.92	51.25	---	74.00	54.00	-2.75	Peak
2390.00	62.30	45.11	2.59	64.89	47.70	74.00	54.00	-6.30	AVG
2484.00	56.21	42.28	2.78	58.99	45.06	74.00	54.00	-8.94	AVG
3990.00	41.72	---	5.83	47.55	---	74.00	54.00	-6.45	Peak
4860.00	38.48	---	8.15	46.63	---	74.00	54.00	-7.37	Peak
7725.00	38.17	---	13.50	51.67	---	74.00	54.00	-2.33	Peak

Remark:

1. Measuring frequencies from 1 GHz to the 10th harmonic of highest fundamental frequency.
2. Average test would be performed if the peak result were greater than the average limit.
3. Data of measurement within this frequency range shown " --- " in the table above means the reading of emissions are attenuated more than 20dB below the permissible limits or the field strength is too small to be measured.
4. Measurements above show only up to 6 maximum emissions noted, or would be lesser, with " N/A " remark, if no specific emissions from the EUT are recorded (ie: margin>20dB from the applicable limit) and considered that's already beyond the background noise floor.
5. Result = Reading + Correction Factor
Margin = Result - Limit
Remark Peak = Result(PK) - Limit(AV)
Remark AVG = Result(AV) - Limit(AV)



Product Name	Computer	Test By	Davis Tseng
Test Model	TREK-572	Test Date	2014/10/29
Test Mode	IEEE 802.11gn HT40 TX / CH High	Temp. & Humidity	25°C, 55%

966 Chamber_B at 3Meter / Horizontal									
Frequency (MHz)	Reading-PK (dBuV)	Reading-AV (dBuV)	Correction Factor (dB/m)	Result-PK (dBuV/m)	Result-AV (dBuV/m)	Limit-PK (dBuV/m)	Limit-AV (dBuV/m)	Margin (dB)	Remark
1934.00	47.51	---	1.20	48.71	---	74.00	54.00	-5.29	Peak
2070.00	47.59	---	1.96	49.55	---	74.00	54.00	-4.45	Peak
2362.00	47.63	---	2.54	50.16	---	74.00	54.00	-3.84	Peak
4485.00	40.14	---	7.36	47.50	---	74.00	54.00	-6.50	Peak
4905.00	40.16	---	8.24	48.40	---	74.00	54.00	-5.60	Peak
7455.00	37.65	---	13.54	51.19	---	74.00	54.00	-2.81	Peak

966 Chamber_B at 3Meter / Vertical									
Frequency (MHz)	Reading-PK (dBuV)	Reading-AV (dBuV)	Correction Factor (dB/m)	Result-PK (dBuV/m)	Result-AV (dBuV/m)	Limit-PK (dBuV/m)	Limit-AV (dBuV/m)	Margin (dB)	Remark
1478.00	48.88	---	-2.90	45.98	---	74.00	54.00	-8.02	Peak
1986.00	47.82	---	1.69	49.51	---	74.00	54.00	-4.49	Peak
2314.00	47.09	---	2.44	49.53	---	74.00	54.00	-4.47	Peak
4875.00	39.02	---	8.18	47.21	---	74.00	54.00	-6.79	Peak
5640.00	38.68	---	9.73	48.40	---	74.00	54.00	-5.60	Peak
6975.00	38.58	---	12.14	50.72	---	74.00	54.00	-3.28	Peak

Remark:

1. Measuring frequencies from 1 GHz to the 10th harmonic of highest fundamental frequency.
2. Average test would be performed if the peak result were greater than the average limit.
3. Data of measurement within this frequency range shown " --- " in the table above means the reading of emissions are attenuated more than 20dB below the permissible limits or the field strength is too small to be measured.
4. Measurements above show only up to 6 maximum emissions noted, or would be lesser, with " N/A " remark, if no specific emissions from the EUT are recorded (ie: margin>20dB from the applicable limit) and considered that's already beyond the background noise floor.
5. Result = Reading + Correction Factor
 Margin = Result - Limit
 Remark Peak = Result(PK) - Limit(AV)
 Remark AVG = Result(AV) - Limit(AV)



Product Name	Computer	Test By	Waternil Guan
Test Model	TREK-572	Test Date	2014/10/30
Test Mode	Bluetooth 4.0 / TX Mode / CH Low	Temp. & Humidity	27°C, 54%

966 Chamber_B at 3Meter / Horizontal									
Frequency (MHz)	Reading-PK (dBuV)	Reading-AV (dBuV)	Correction Factor (dB/m)	Result-PK (dBuV/m)	Result-AV (dBuV/m)	Limit-PK (dBuV/m)	Limit-AV (dBuV/m)	Margin (dB)	Remark
2322.00	53.19	44.25	2.46	55.65	46.71	74.00	54.00	-7.29	AVG
2482.00	51.35	42.61	2.77	54.12	45.38	74.00	54.00	-8.62	AVG
2562.00	44.82	---	2.97	47.79	---	74.00	54.00	-6.21	Peak
4800.00	38.76	---	8.03	46.79	---	74.00	54.00	-7.21	Peak
5040.00	40.26	---	8.51	48.77	---	74.00	54.00	-5.23	Peak
6270.00	38.75	---	11.59	50.35	---	74.00	54.00	-3.65	Peak

966 Chamber_B at 3Meter / Vertical									
Frequency (MHz)	Reading-PK (dBuV)	Reading-AV (dBuV)	Correction Factor (dB/m)	Result-PK (dBuV/m)	Result-AV (dBuV/m)	Limit-PK (dBuV/m)	Limit-AV (dBuV/m)	Margin (dB)	Remark
1662.00	44.47	---	-1.37	43.10	---	74.00	54.00	-10.90	Peak
2322.00	46.14	---	2.46	48.59	---	74.00	54.00	-5.41	Peak
2482.00	46.86	---	2.77	49.63	---	74.00	54.00	-4.37	Peak
4740.00	40.09	---	7.90	48.00	---	74.00	54.00	-6.00	Peak
5070.00	40.06	---	8.56	48.63	---	74.00	54.00	-5.37	Peak
6045.00	38.78	---	10.93	49.72	---	74.00	54.00	-4.28	Peak

Remark:

1. Measuring frequencies from 1 GHz to the 10th harmonic of highest fundamental frequency.
2. Average test would be performed if the peak result were greater than the average limit.
3. Data of measurement within this frequency range shown " --- " in the table above means the reading of emissions are attenuated more than 20dB below the permissible limits or the field strength is too small to be measured.
4. Measurements above show only up to 6 maximum emissions noted, or would be lesser, with " N/A " remark, if no specific emissions from the EUT are recorded (ie: margin>20dB from the applicable limit) and considered that's already beyond the background noise floor.
5. Result = Reading + Correction Factor
Margin = Result - Limit
Remark Peak = Result(PK) - Limit(AV)
Remark AVG = Result(AV) - Limit(AV)



Product Name	Computer	Test By	Waternil Guan
Test Model	TREK-572	Test Date	2014/10/30
Test Mode	Bluetooth 4.0 / TX Mode / CH Middle	Temp. & Humidity	27°C, 54%

966 Chamber_B at 3Meter / Horizontal									
Frequency (MHz)	Reading-PK (dBuV)	Reading-AV (dBuV)	Correction Factor (dB/m)	Result-PK (dBuV/m)	Result-AV (dBuV/m)	Limit-PK (dBuV/m)	Limit-AV (dBuV/m)	Margin (dB)	Remark
1734.00	47.49	---	-0.69	46.80	---	74.00	54.00	-7.20	Peak
2360.00	48.14	---	2.53	50.67	---	74.00	54.00	-3.33	Peak
2520.00	47.32	---	2.86	50.18	---	74.00	54.00	-3.82	Peak
4890.00	38.39	---	8.21	46.61	---	74.00	54.00	-7.39	Peak
6030.00	38.89	---	10.89	49.78	---	74.00	54.00	-4.22	Peak
6465.00	39.17	---	12.17	51.34	---	74.00	54.00	-2.66	Peak

966 Chamber_B at 3Meter / Vertical									
Frequency (MHz)	Reading-PK (dBuV)	Reading-AV (dBuV)	Correction Factor (dB/m)	Result-PK (dBuV/m)	Result-AV (dBuV/m)	Limit-PK (dBuV/m)	Limit-AV (dBuV/m)	Margin (dB)	Remark
1908.00	43.62	---	0.95	44.57	---	74.00	54.00	-9.43	Peak
2360.00	45.59	---	2.53	48.12	---	74.00	54.00	-5.88	Peak
2520.00	44.53	---	2.86	47.39	---	74.00	54.00	-6.61	Peak
4845.00	39.19	---	8.12	47.31	---	74.00	54.00	-6.69	Peak
5220.00	40.14	---	8.82	48.96	---	74.00	54.00	-5.04	Peak
6510.00	38.72	---	12.27	50.99	---	74.00	54.00	-3.01	Peak

Remark:

1. Measuring frequencies from 1 GHz to the 10th harmonic of highest fundamental frequency.
2. Average test would be performed if the peak result were greater than the average limit.
3. Data of measurement within this frequency range shown " --- " in the table above means the reading of emissions are attenuated more than 20dB below the permissible limits or the field strength is too small to be measured.
4. Measurements above show only up to 6 maximum emissions noted, or would be lesser, with " N/A " remark, if no specific emissions from the EUT are recorded (ie: margin>20dB from the applicable limit) and considered that's already beyond the background noise floor.
5. Result = Reading + Correction Factor
Margin = Result - Limit
Remark Peak = Result(PK) - Limit(AV)
Remark AVG = Result(AV) - Limit(AV)



Product Name	Computer	Test By	Waternil Guan
Test Model	TREK-572	Test Date	2014/10/30
Test Mode	Bluetooth 4.0 / TX Mode / CH High	Temp. & Humidity	27°C, 54%

966 Chamber_B at 3Meter / Horizontal									
Frequency (MHz)	Reading-PK (dBuV)	Reading-AV (dBuV)	Correction Factor (dB/m)	Result-PK (dBuV/m)	Result-AV (dBuV/m)	Limit-PK (dBuV/m)	Limit-AV (dBuV/m)	Margin (dB)	Remark
2288.00	44.86	---	2.39	47.25	---	74.00	54.00	-6.75	Peak
2560.00	47.05	---	2.96	50.01	---	74.00	54.00	-3.99	Peak
2672.00	43.41	---	3.25	46.66	---	74.00	54.00	-7.34	Peak
4950.00	39.63	---	8.34	47.97	---	74.00	54.00	-6.03	Peak
5355.00	39.58	---	9.06	48.64	---	74.00	54.00	-5.36	Peak
6540.00	39.79	---	12.26	52.05	---	74.00	54.00	-1.95	Peak

966 Chamber_B at 3Meter / Vertical									
Frequency (MHz)	Reading-PK (dBuV)	Reading-AV (dBuV)	Correction Factor (dB/m)	Result-PK (dBuV/m)	Result-AV (dBuV/m)	Limit-PK (dBuV/m)	Limit-AV (dBuV/m)	Margin (dB)	Remark
1826.00	42.98	---	0.18	43.16	---	74.00	54.00	-10.84	Peak
2012.00	42.58	---	1.84	44.43	---	74.00	54.00	-9.57	Peak
2560.00	43.87	---	2.96	46.83	---	74.00	54.00	-7.17	Peak
4725.00	39.85	---	7.87	47.72	---	74.00	54.00	-6.28	Peak
4995.00	39.25	---	8.43	47.68	---	74.00	54.00	-6.32	Peak
6270.00	38.29	---	11.59	49.88	---	74.00	54.00	-4.12	Peak

Remark:

1. Measuring frequencies from 1 GHz to the 10th harmonic of highest fundamental frequency.
2. Average test would be performed if the peak result were greater than the average limit.
3. Data of measurement within this frequency range shown " --- " in the table above means the reading of emissions are attenuated more than 20dB below the permissible limits or the field strength is too small to be measured.
4. Measurements above show only up to 6 maximum emissions noted, or would be lesser, with " N/A " remark, if no specific emissions from the EUT are recorded (ie: margin>20dB from the applicable limit) and considered that's already beyond the background noise floor.
5. Result = Reading + Correction Factor
Margin = Result - Limit
Remark Peak = Result(PK) - Limit(AV)
Remark AVG = Result(AV) - Limit(AV)



Restricted Band Edges

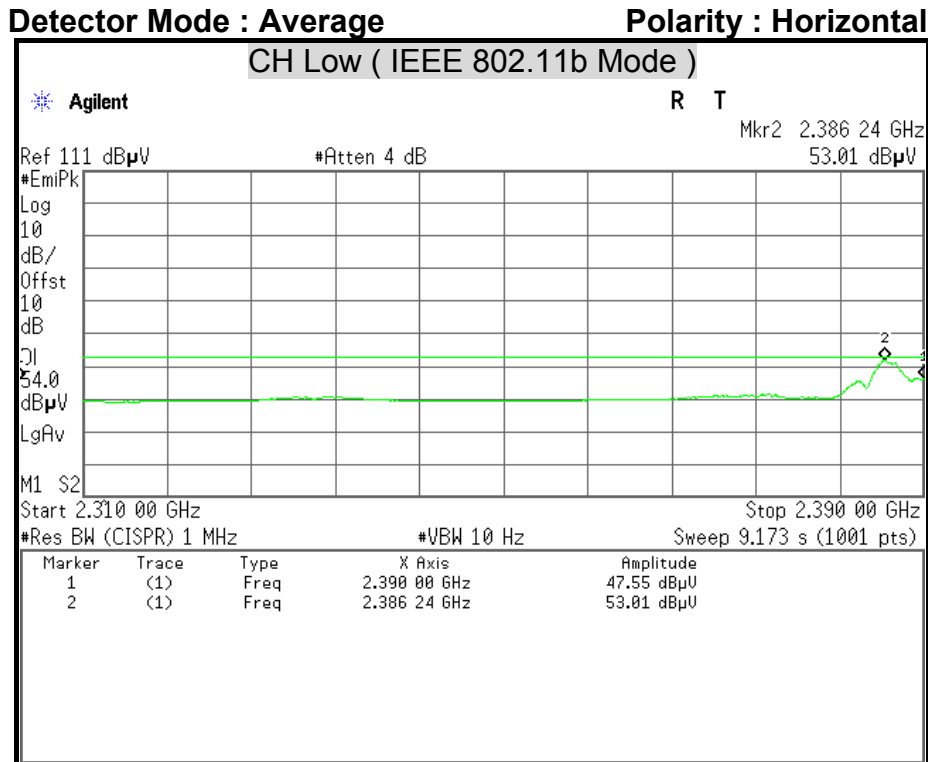
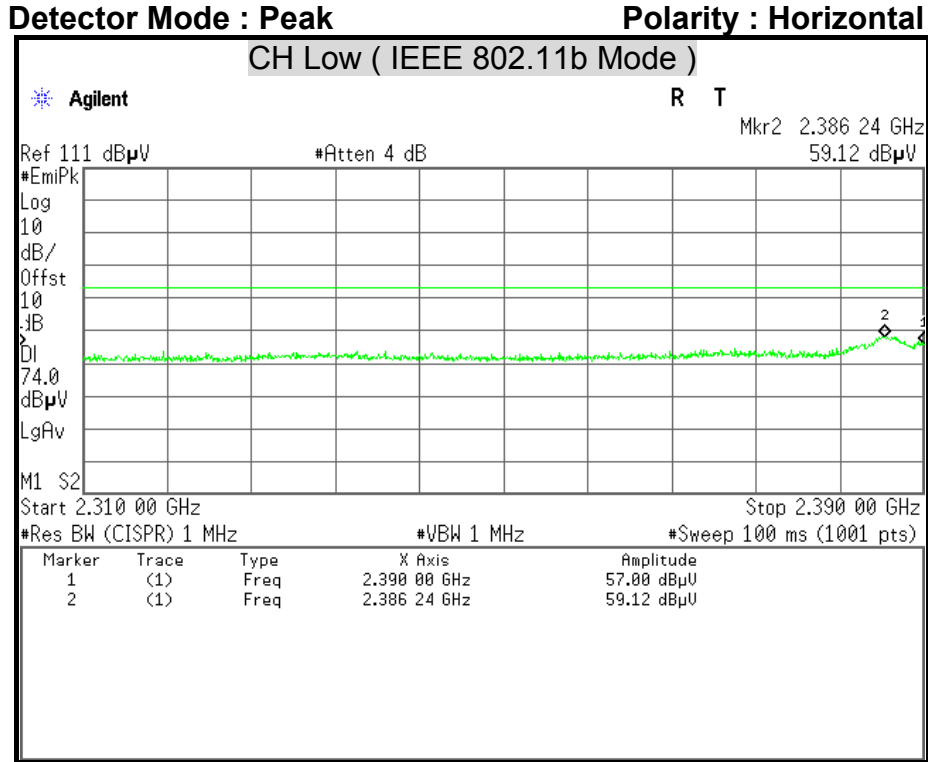



Detector Mode : Peak

Polarity : Vertical

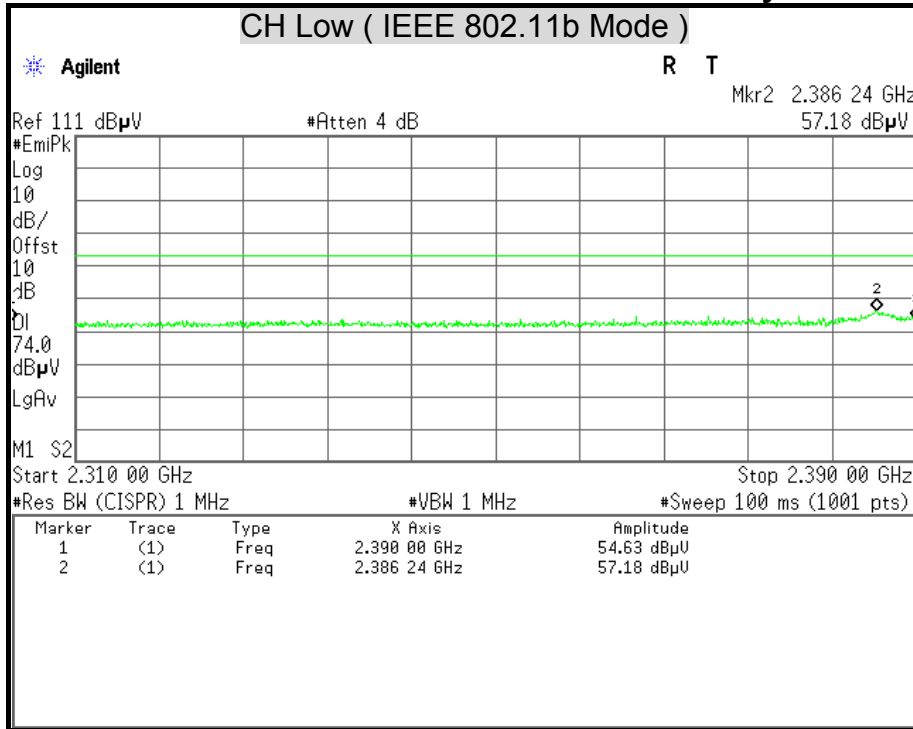

Detector Mode : Average

Polarity : Vertical

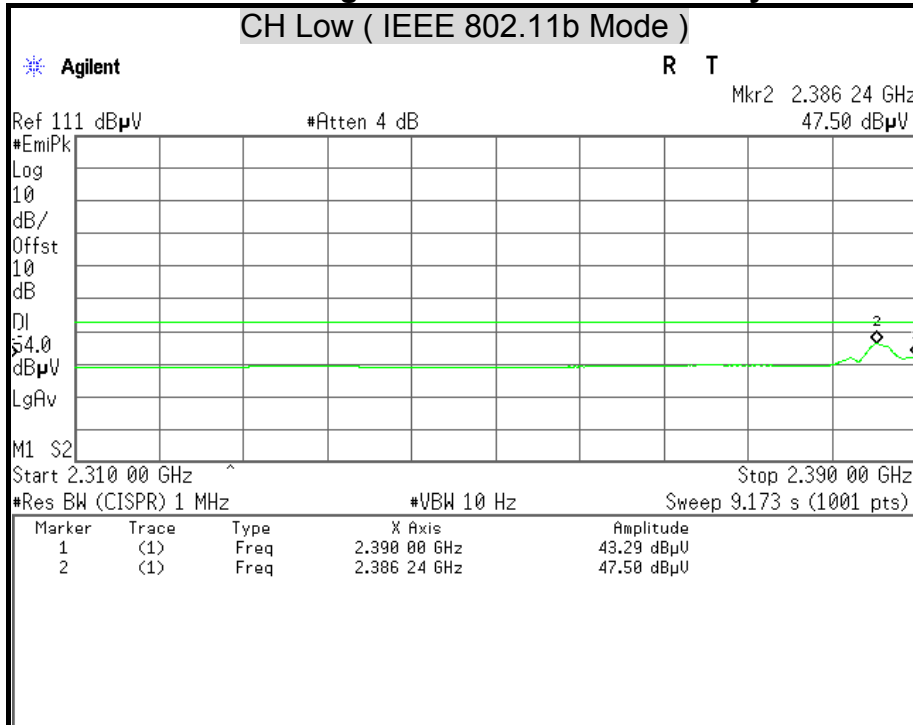



Detector Mode : Peak

Polarity : Horizontal

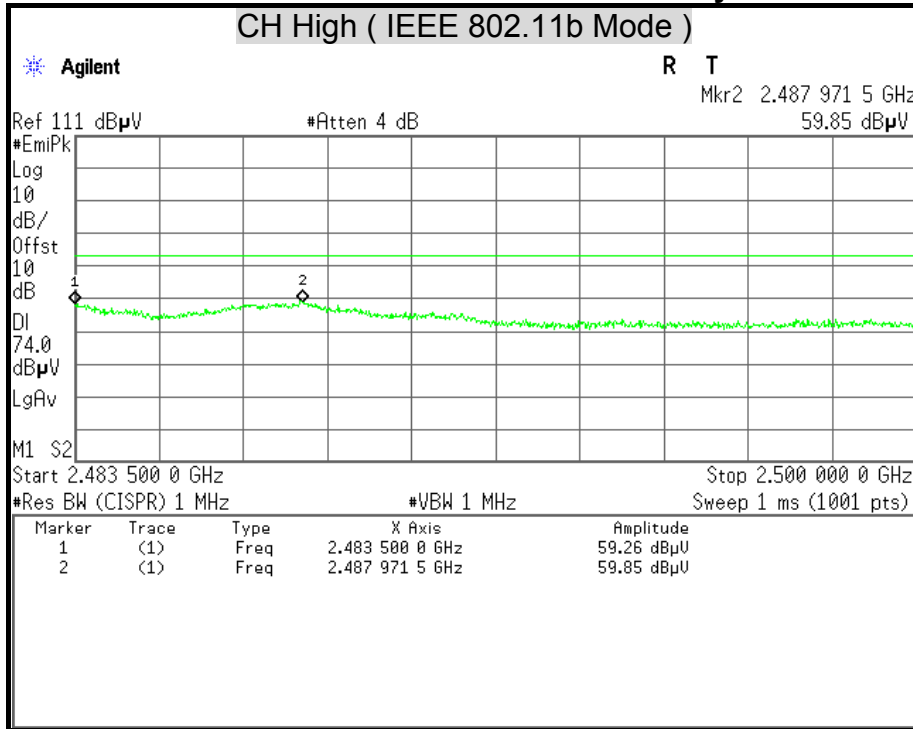

Detector Mode : Average

Polarity : Horizontal

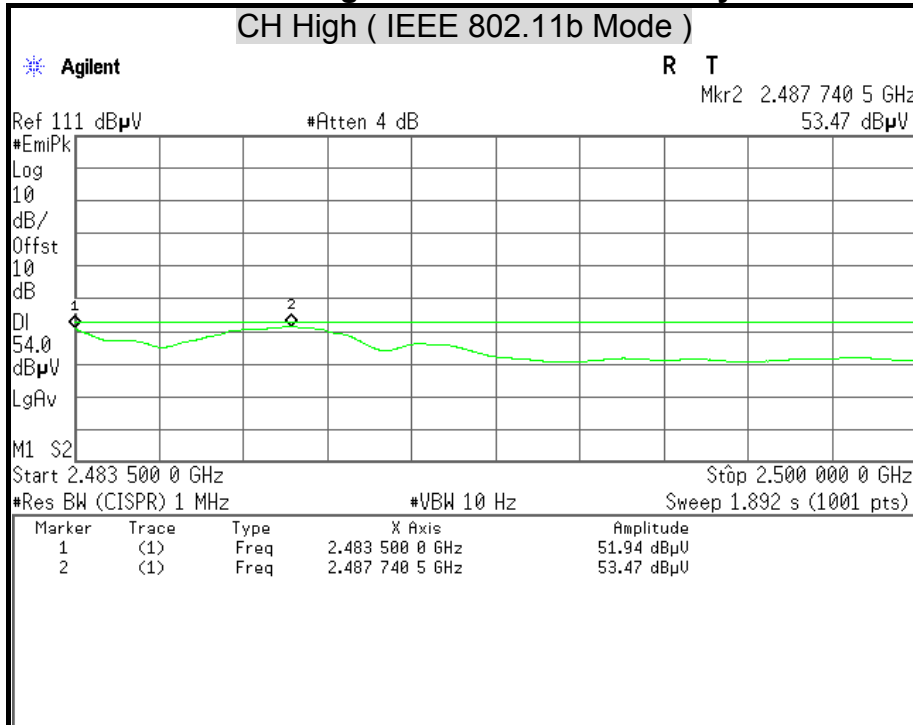



Detector Mode : Peak

Polarity : Vertical

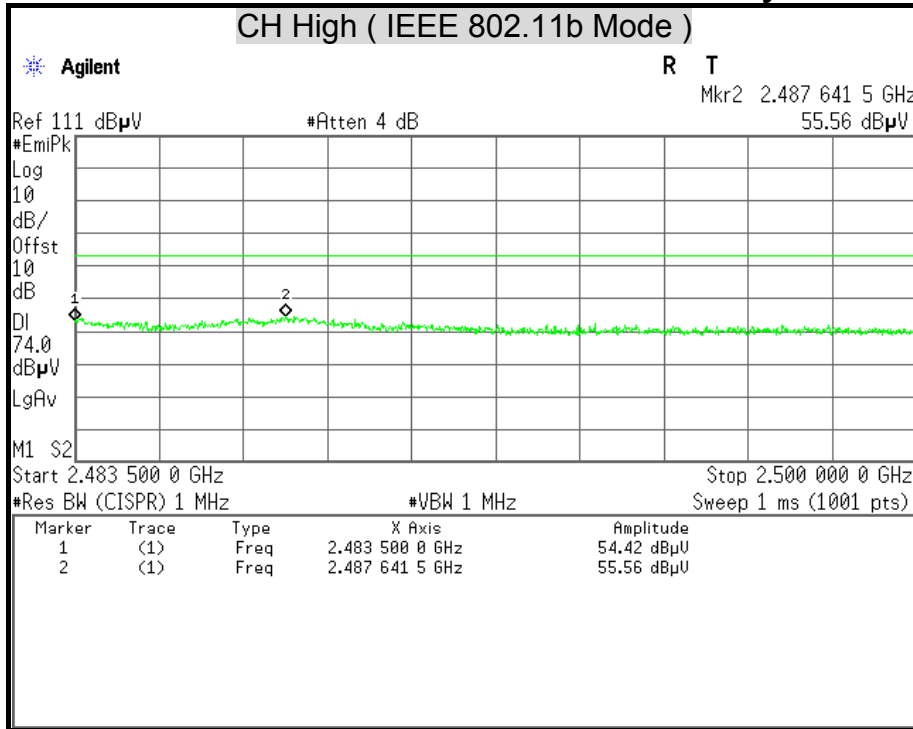

Detector Mode : Average

Polarity : Vertical

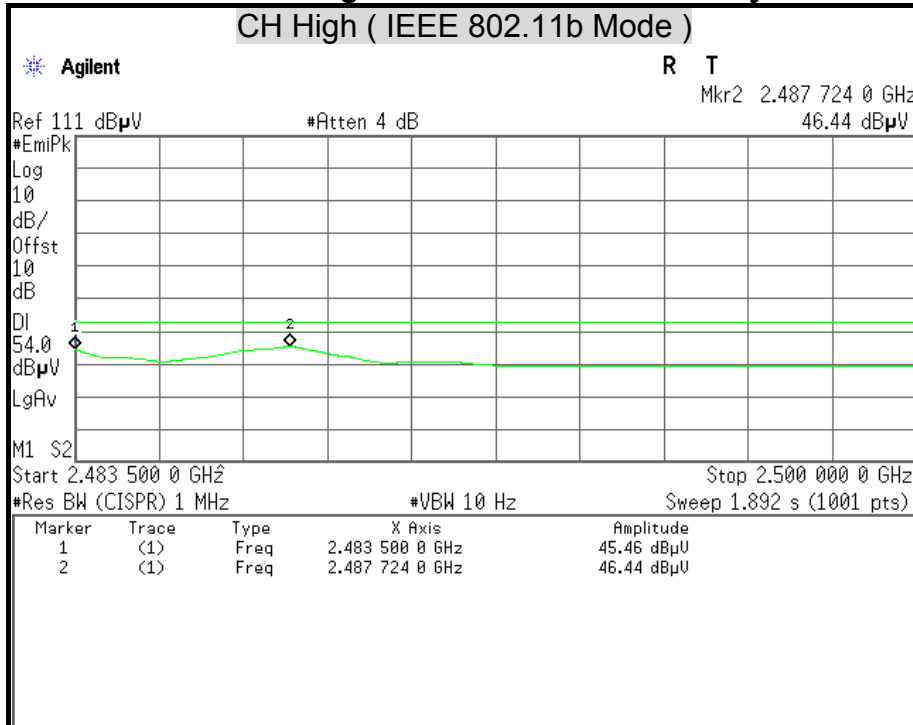



Detector Mode : Peak

Polarity : Horizontal

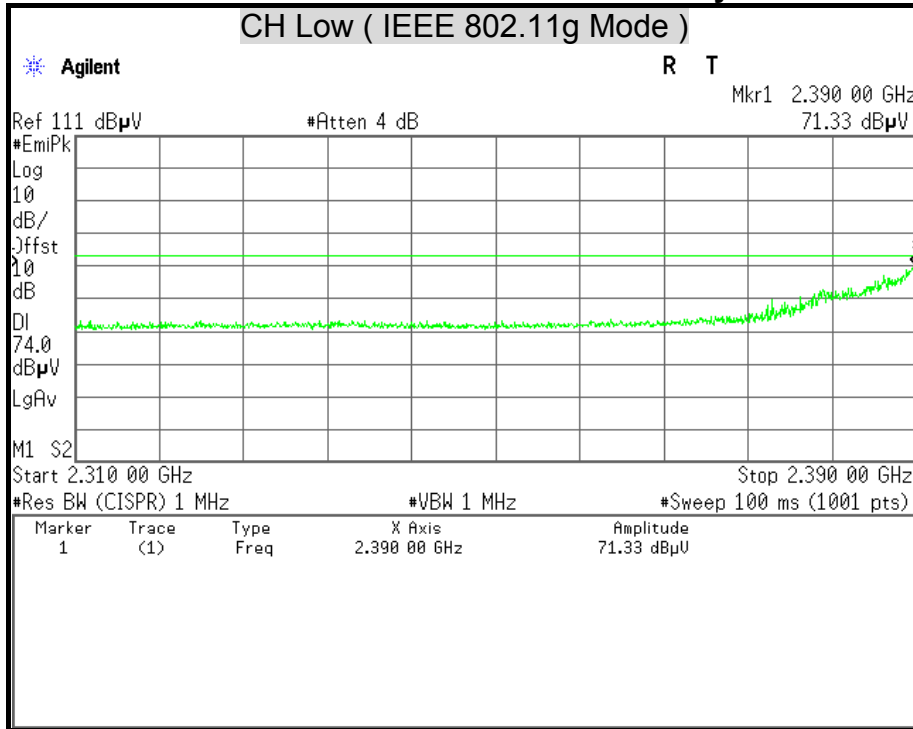

Detector Mode : Average

Polarity : Horizontal

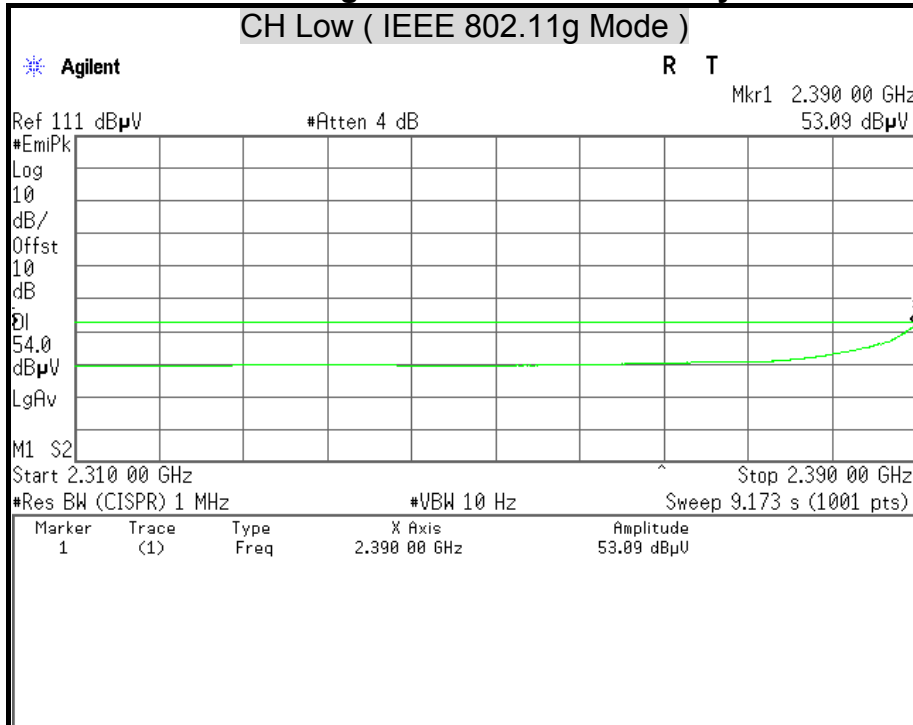



Detector Mode : Peak

Polarity : Vertical

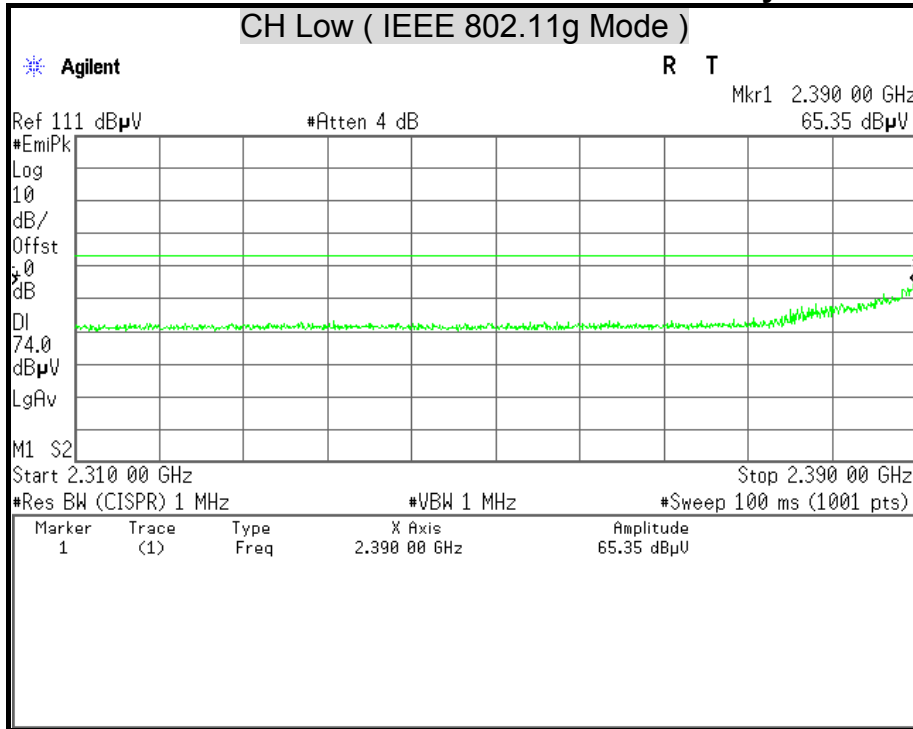

Detector Mode : Average

Polarity : Vertical

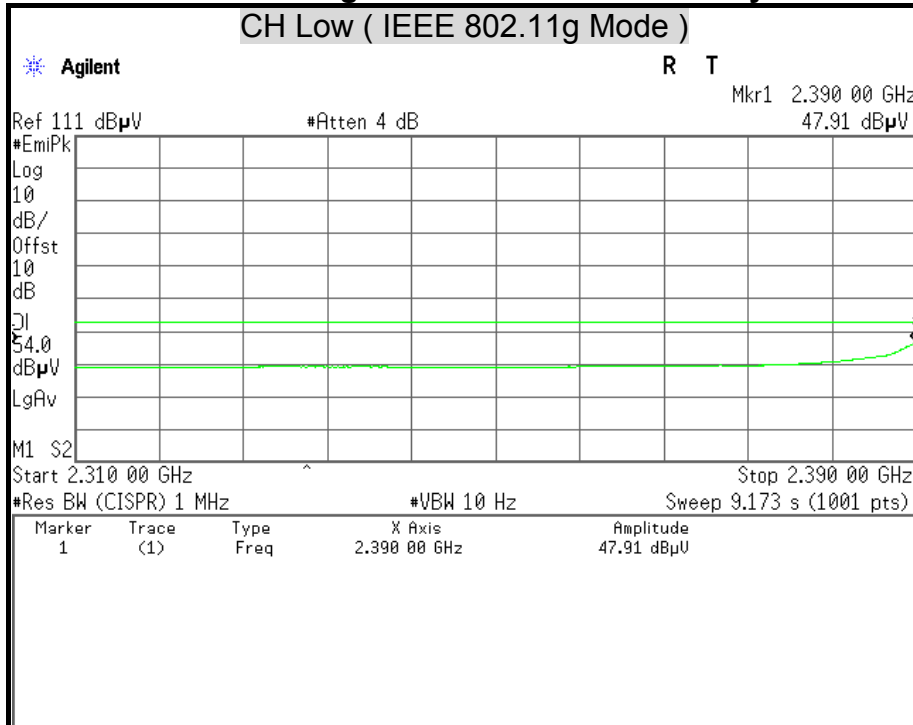



Detector Mode : Peak

Polarity : Horizontal

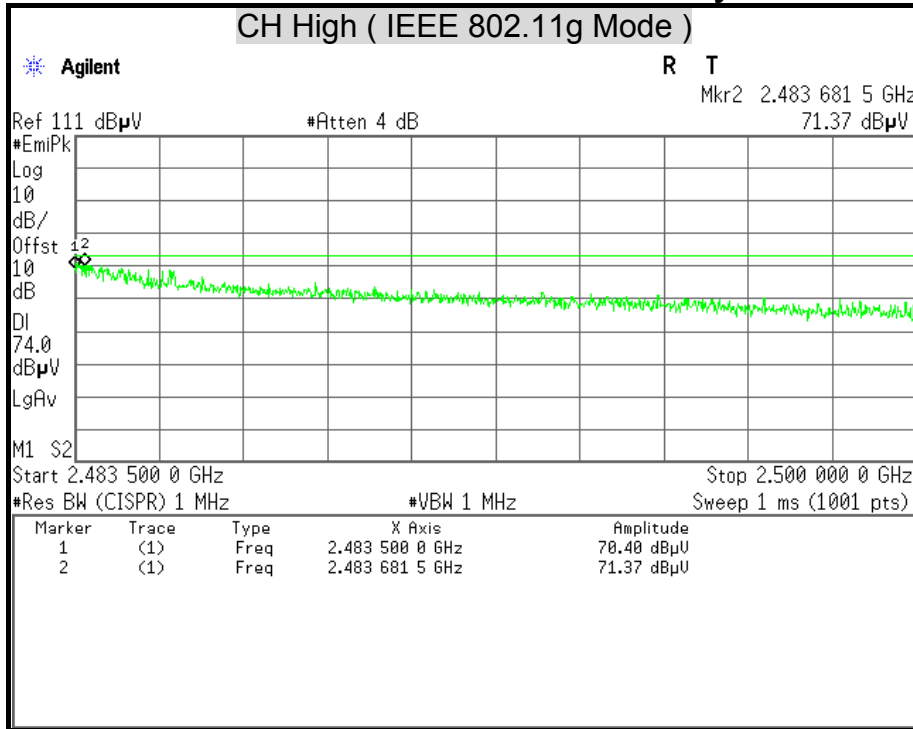

Detector Mode : Average

Polarity : Horizontal

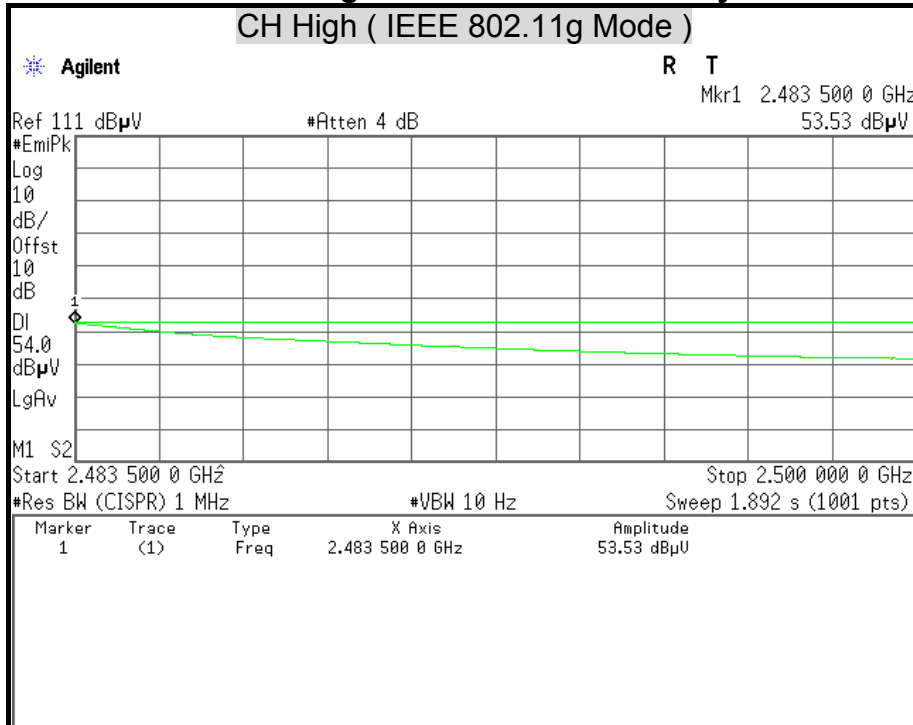



Detector Mode : Peak

Polarity : Vertical

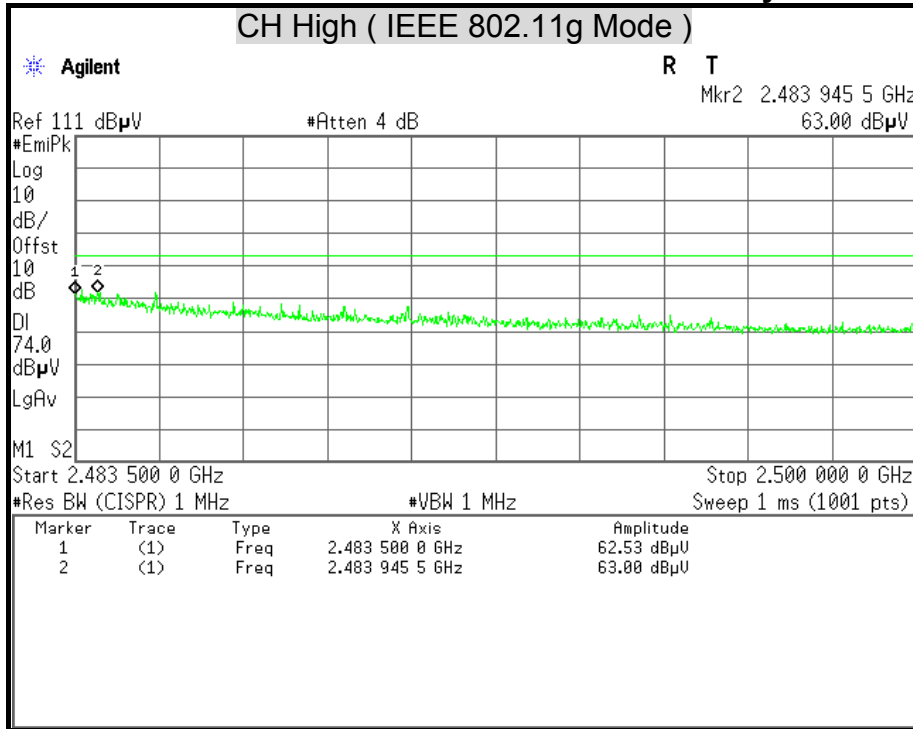

Detector Mode : Average

Polarity : Vertical

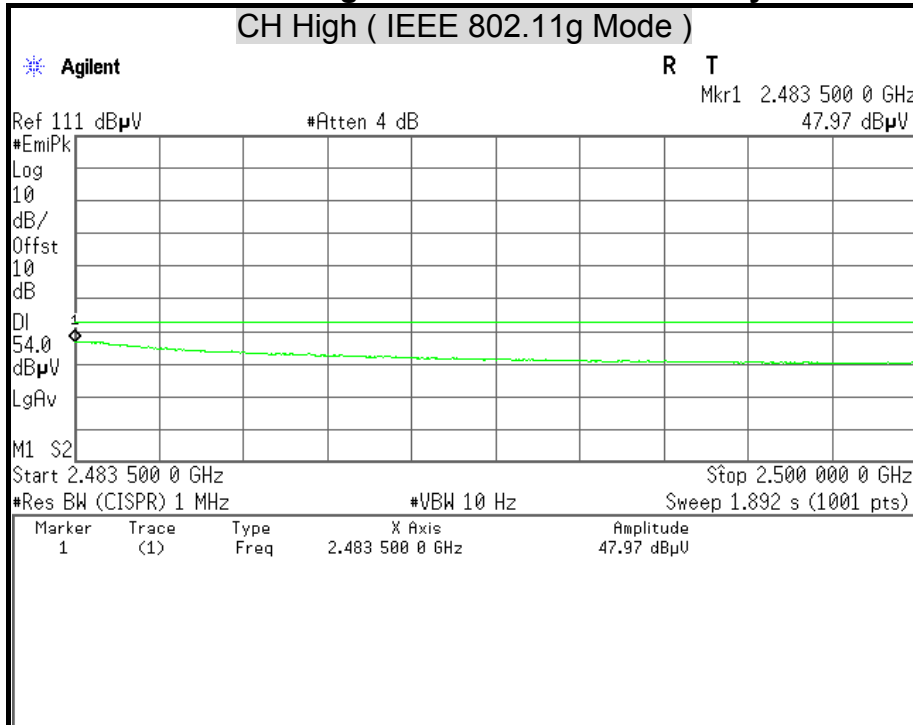



Detector Mode : Peak

Polarity : Horizontal

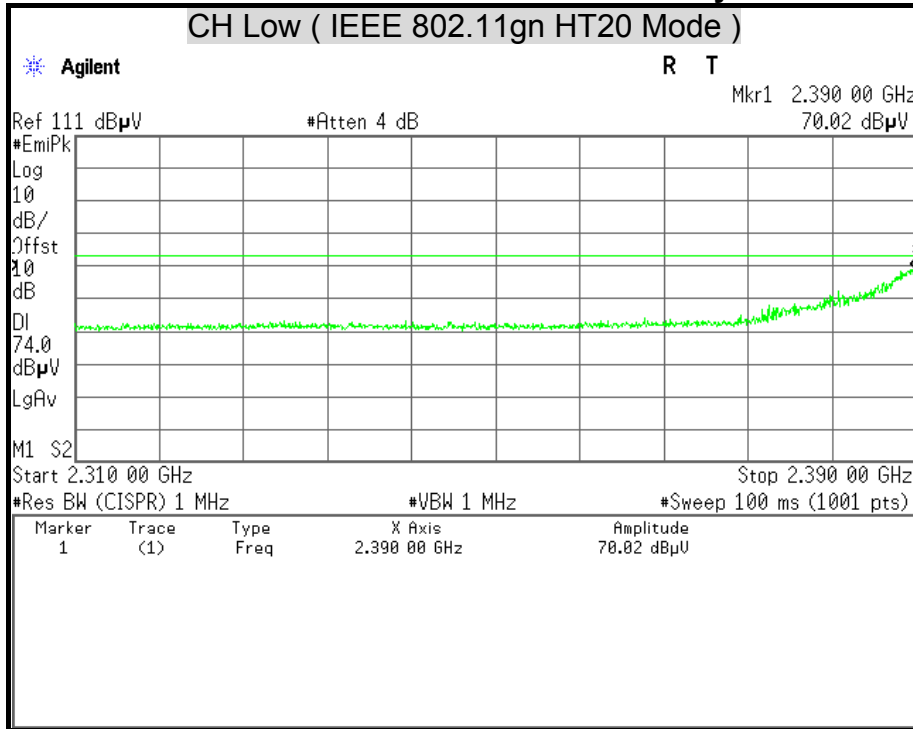

Detector Mode : Average

Polarity : Horizontal

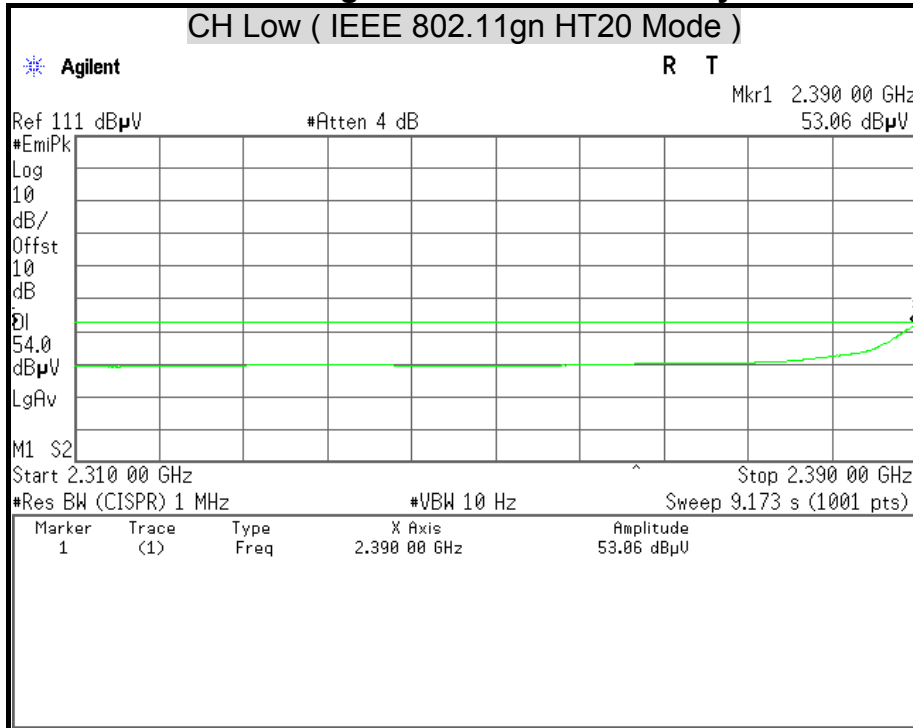



Detector Mode : Peak

Polarity : Vertical

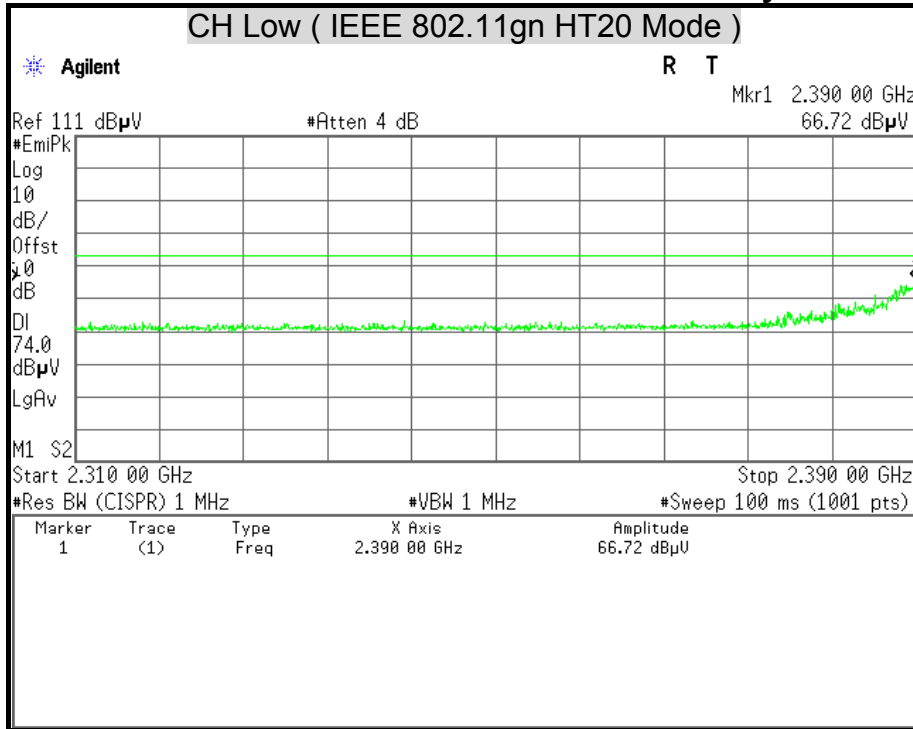

Detector Mode : Average

Polarity : Vertical

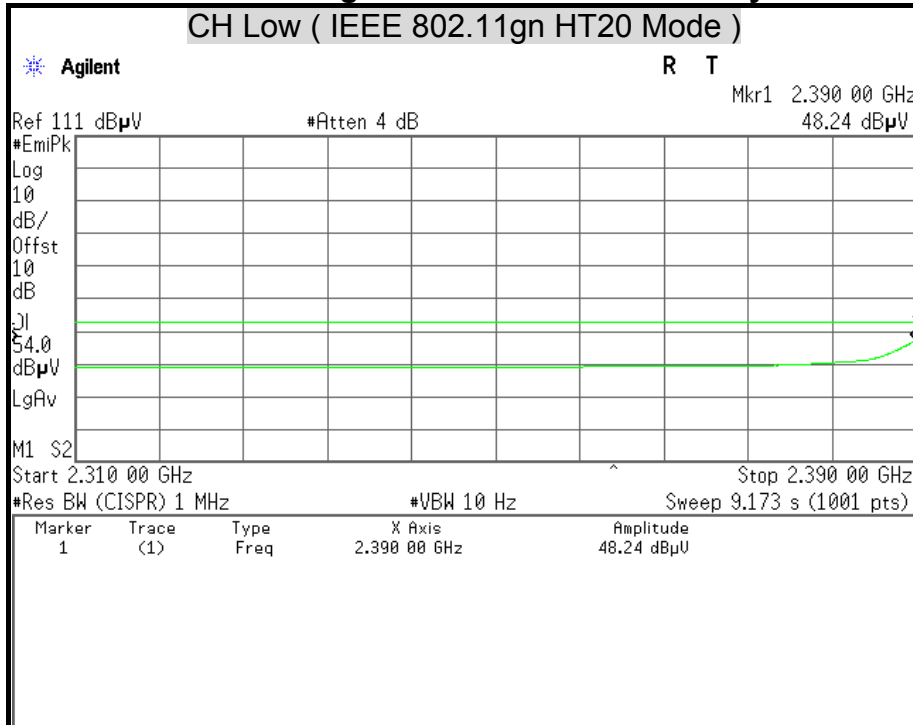



Detector Mode : Peak

Polarity : Horizontal

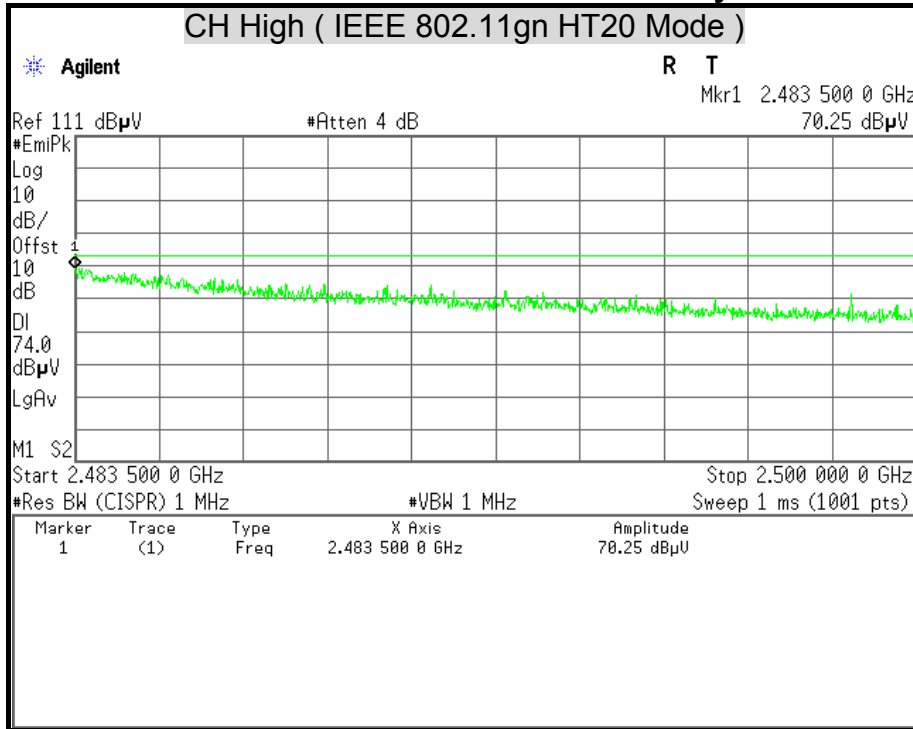

Detector Mode : Average

Polarity : Horizontal

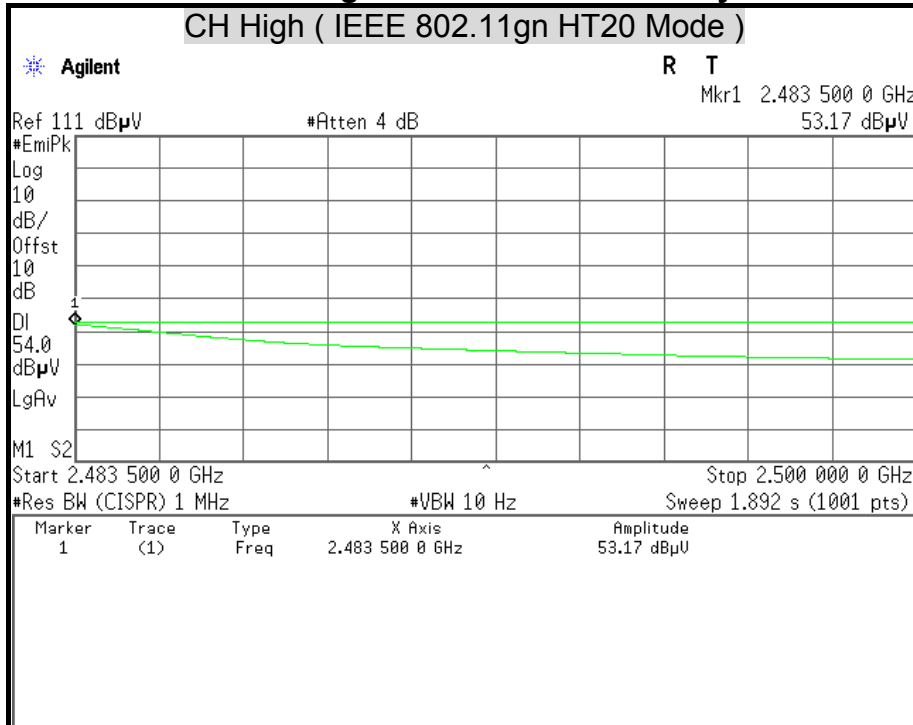



Detector Mode : Peak

Polarity : Vertical

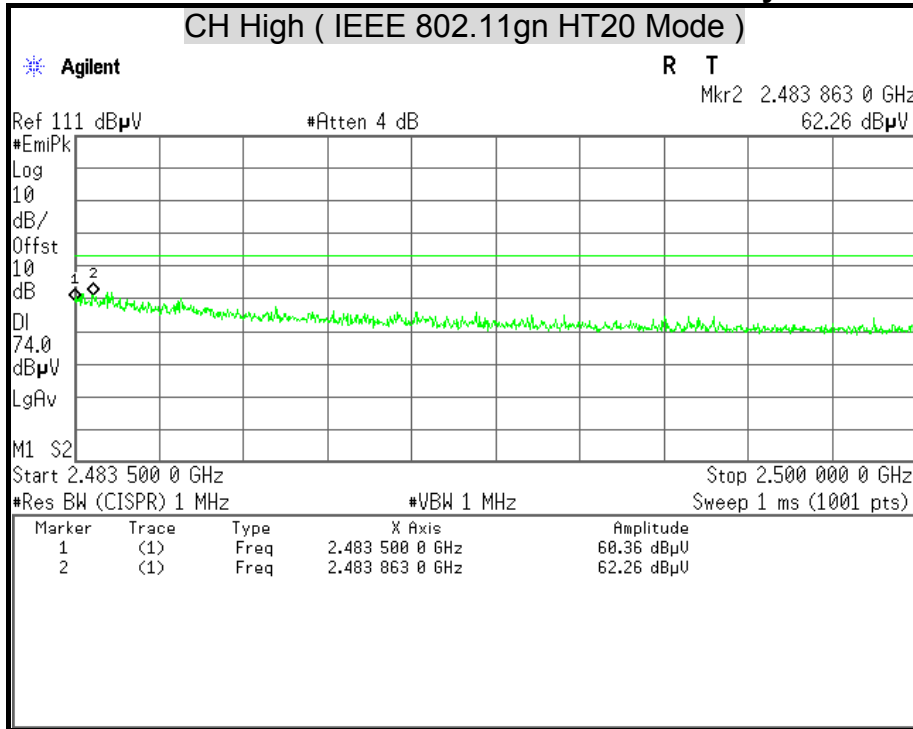

Detector Mode : Average

Polarity : Vertical

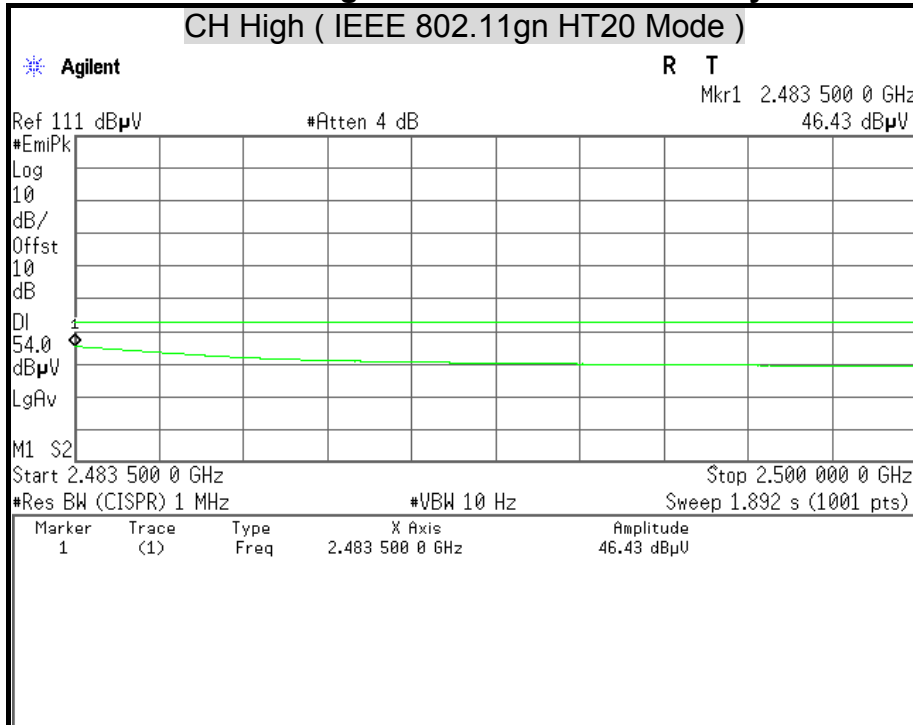



Detector Mode : Peak

Polarity : Horizontal

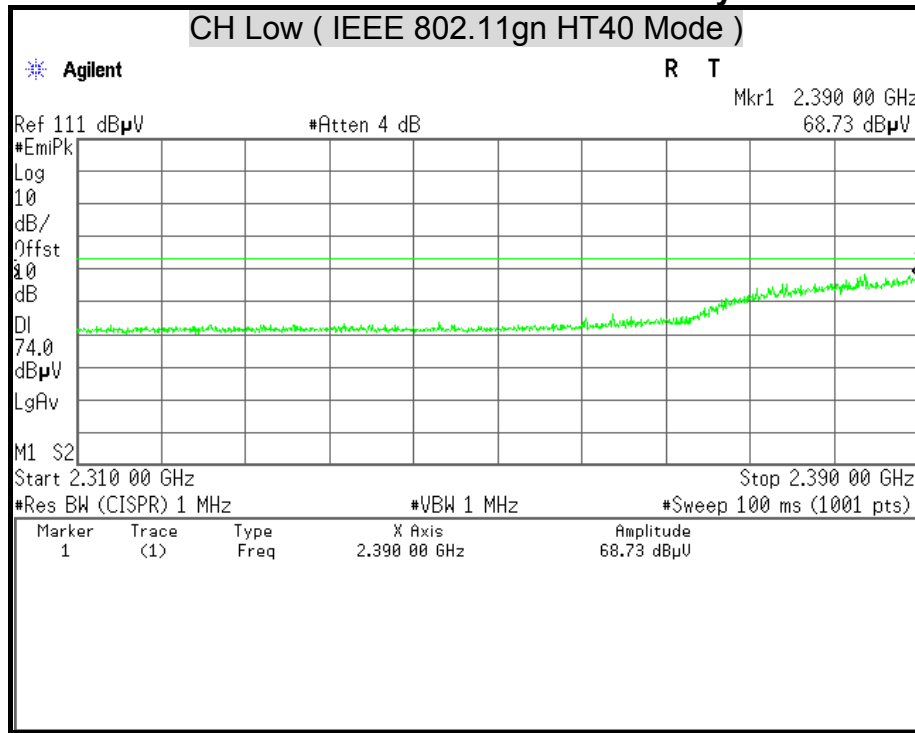

Detector Mode : Average

Polarity : Horizontal

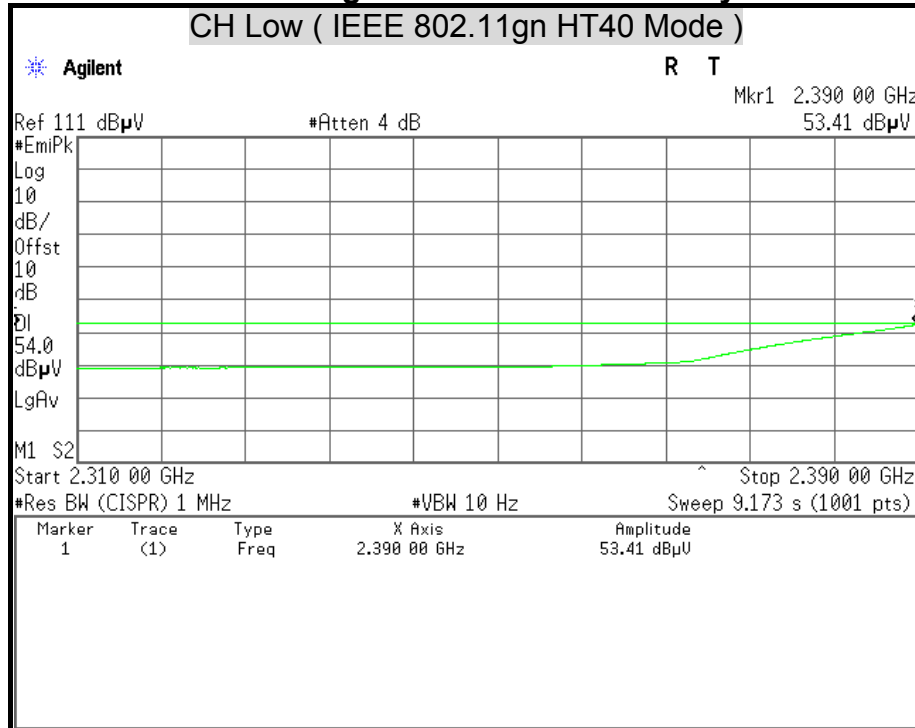



Detector Mode : Peak

Polarity : Vertical

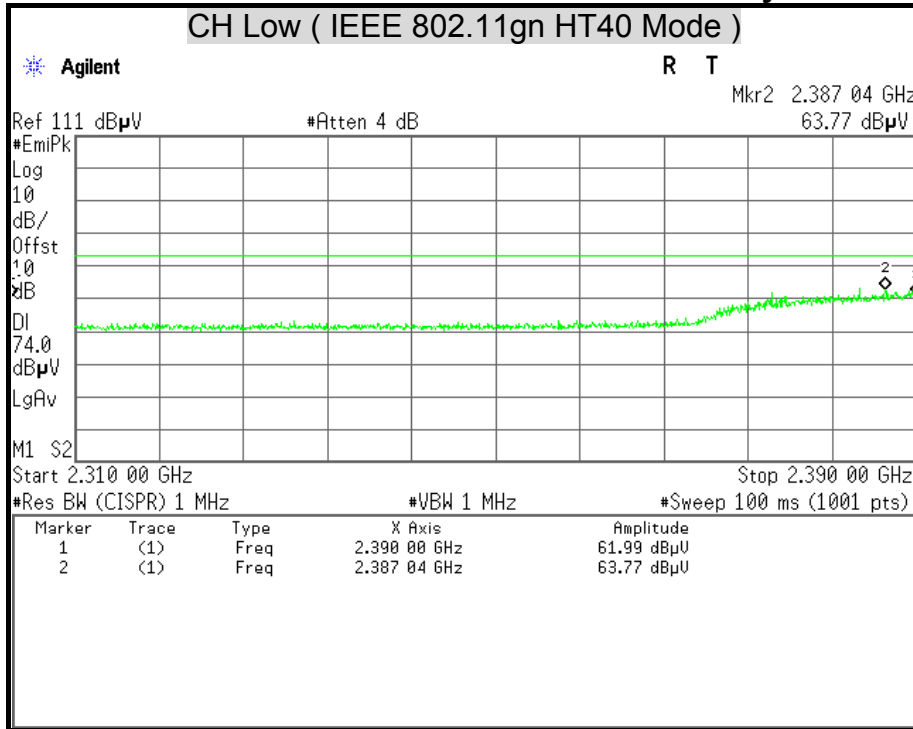

Detector Mode : Average

Polarity : Vertical

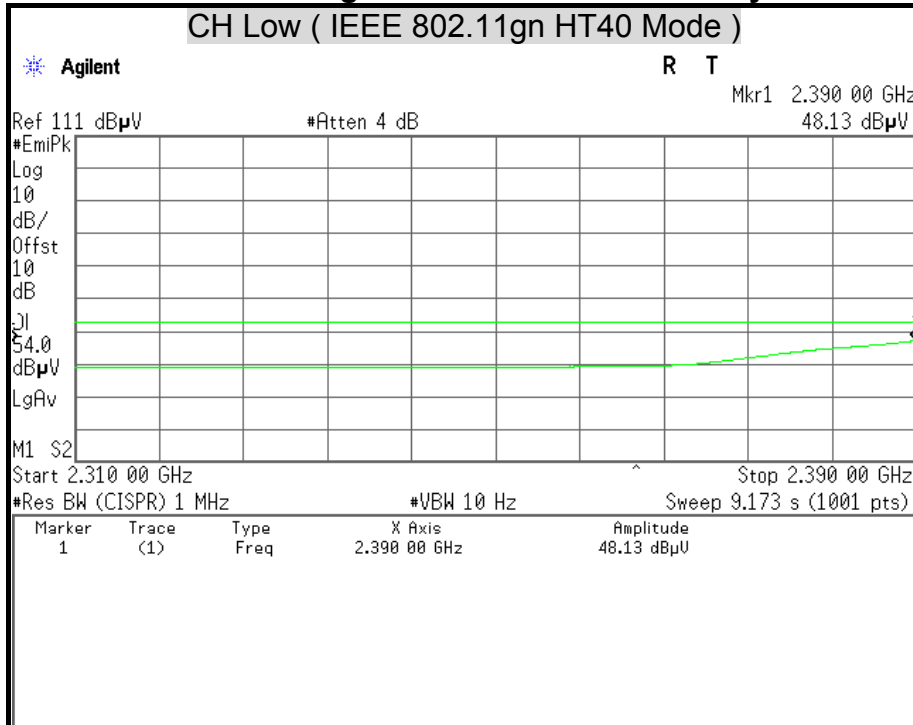



Detector Mode : Peak

Polarity : Horizontal

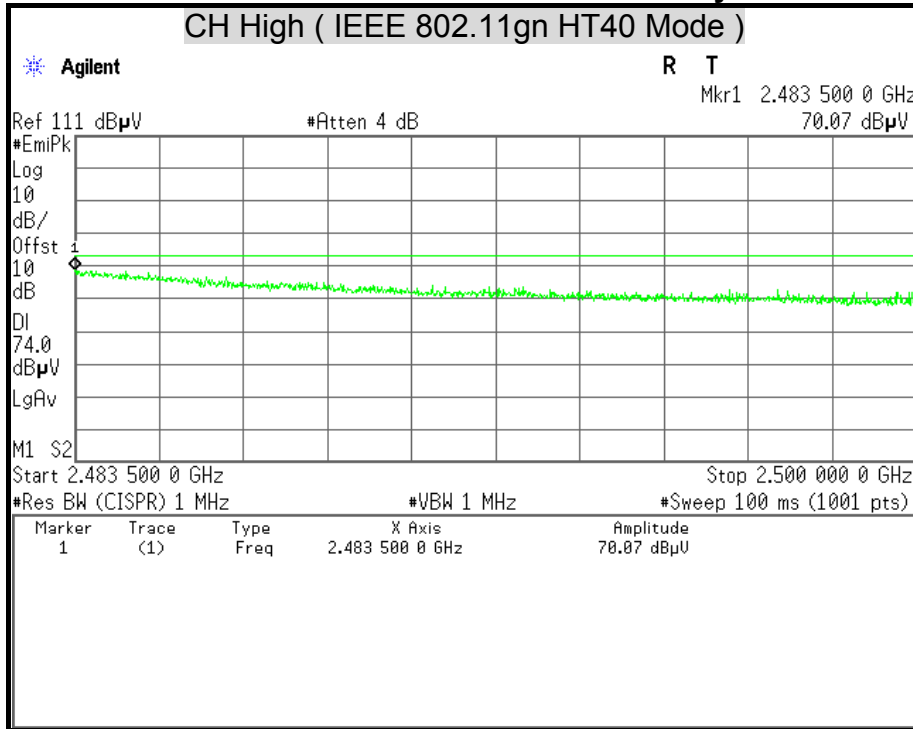

Detector Mode : Average

Polarity : Horizontal

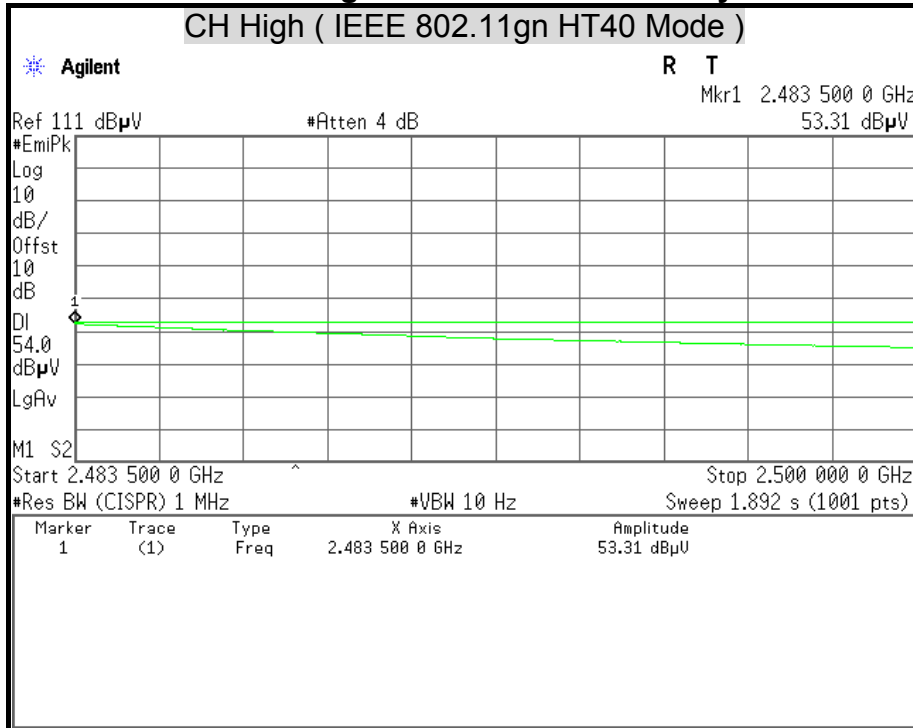



Detector Mode : Peak

Polarity : Vertical

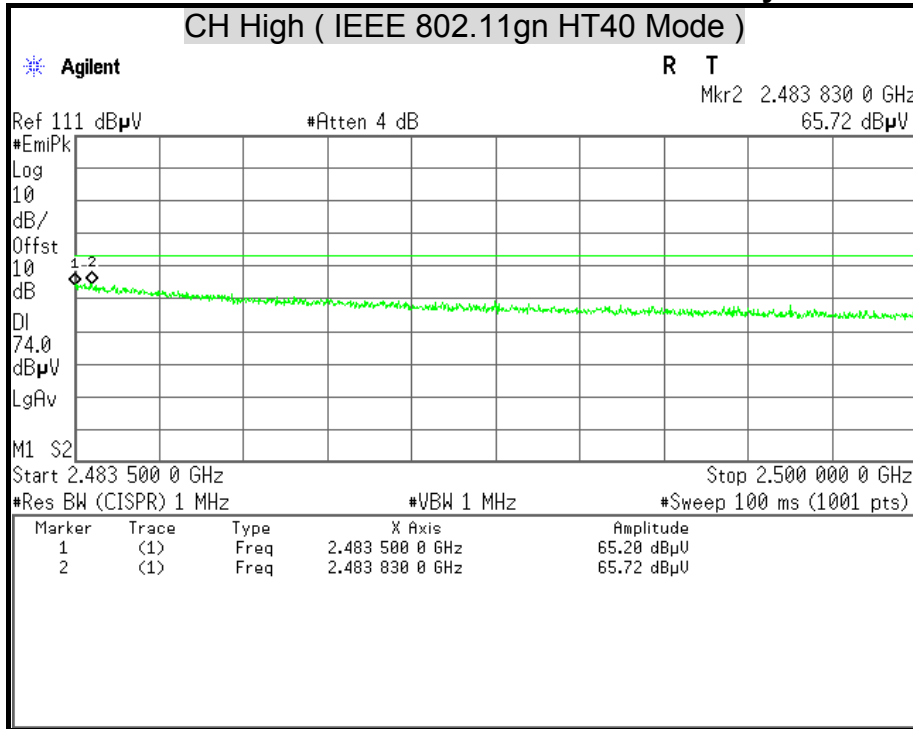

Detector Mode : Average

Polarity : Vertical

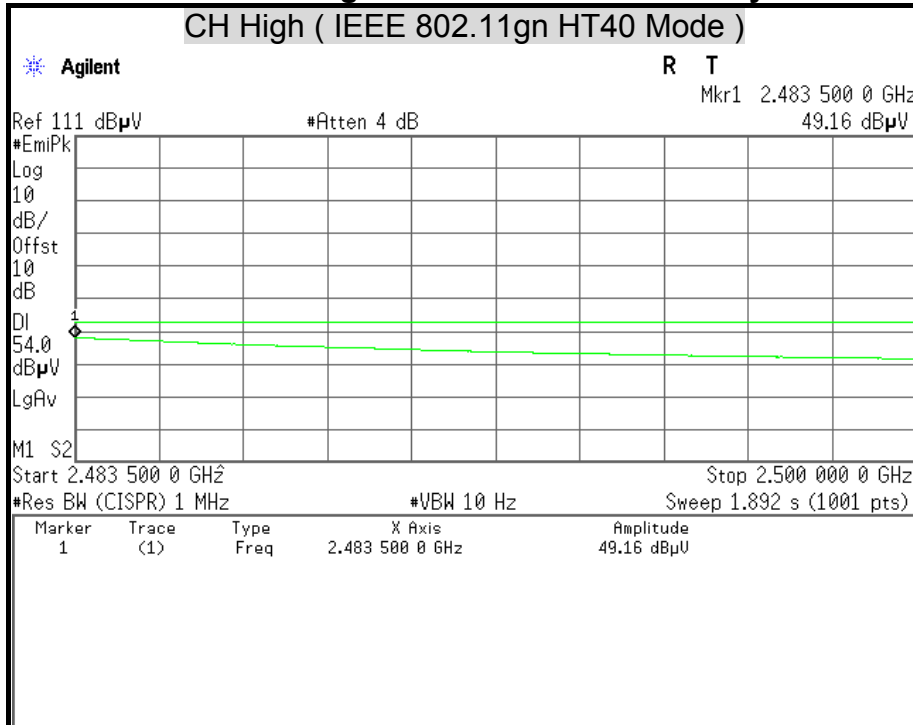



Detector Mode : Peak

Polarity : Horizontal

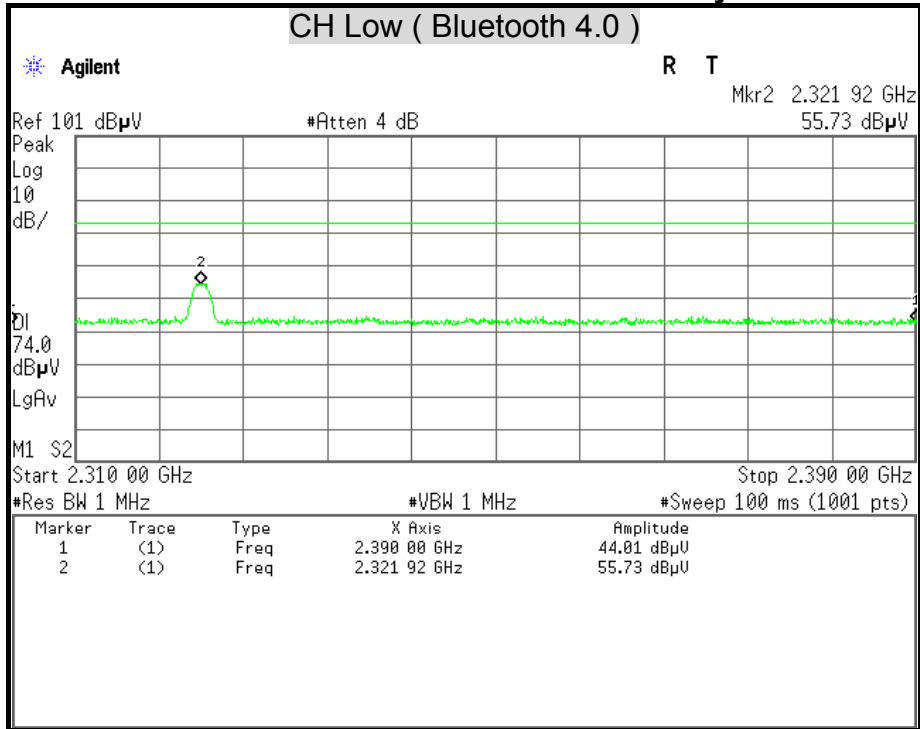

Detector Mode : Average

Polarity : Horizontal

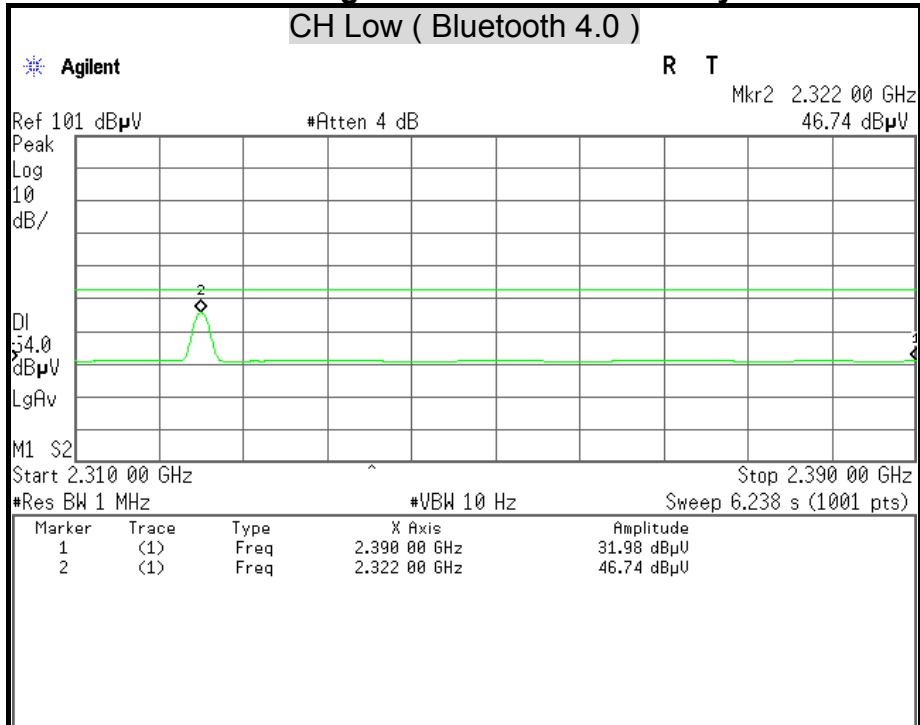



Detector Mode : Peak

Polarity : Vertical

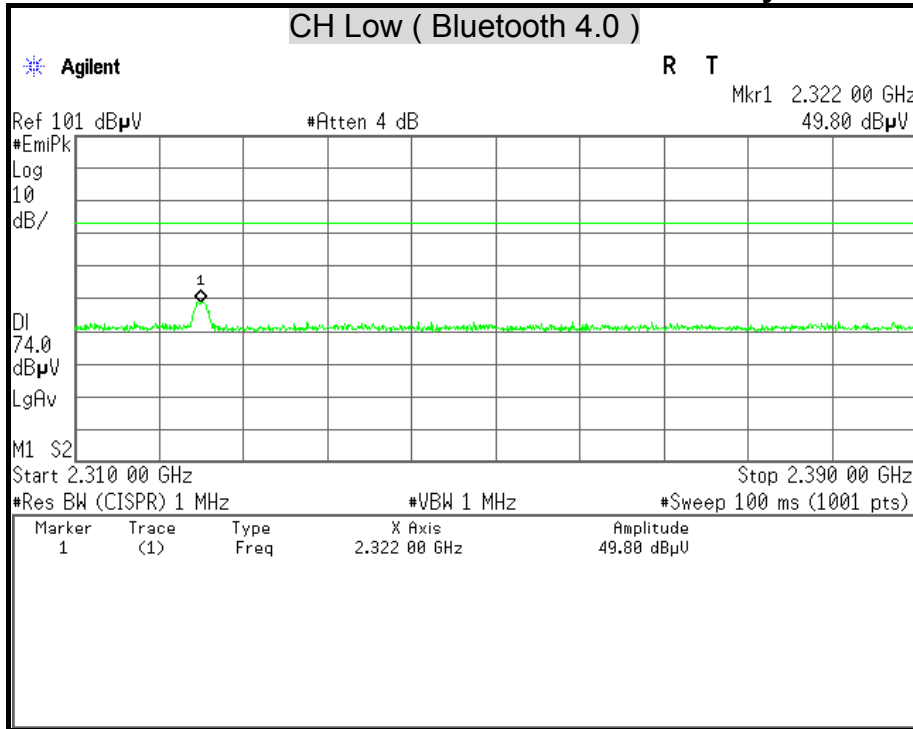

Detector Mode : Average

Polarity : Vertical

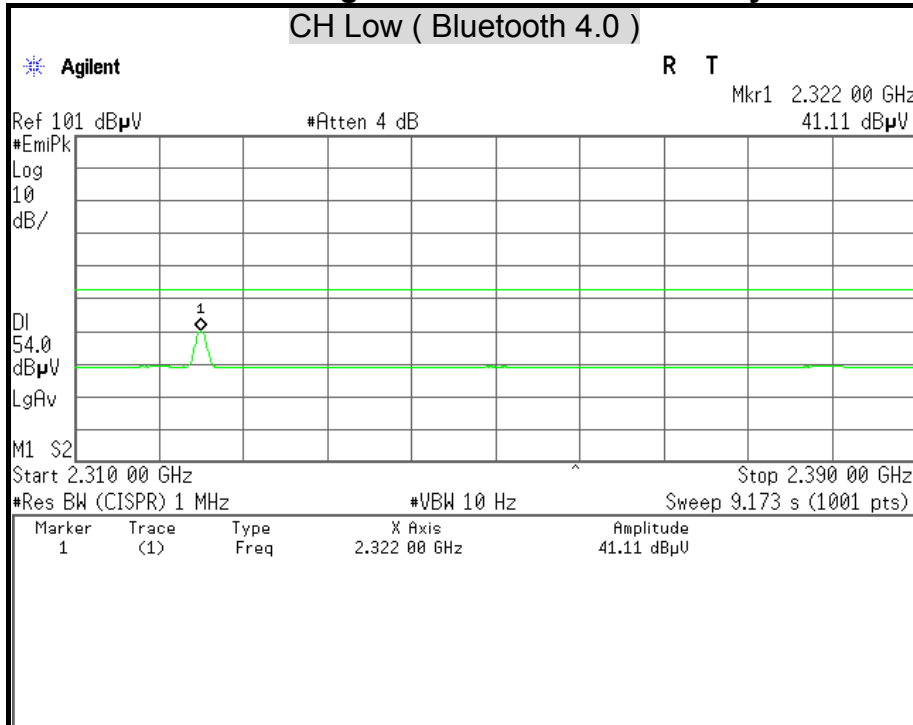



Detector Mode : Peak

Polarity : Horizontal

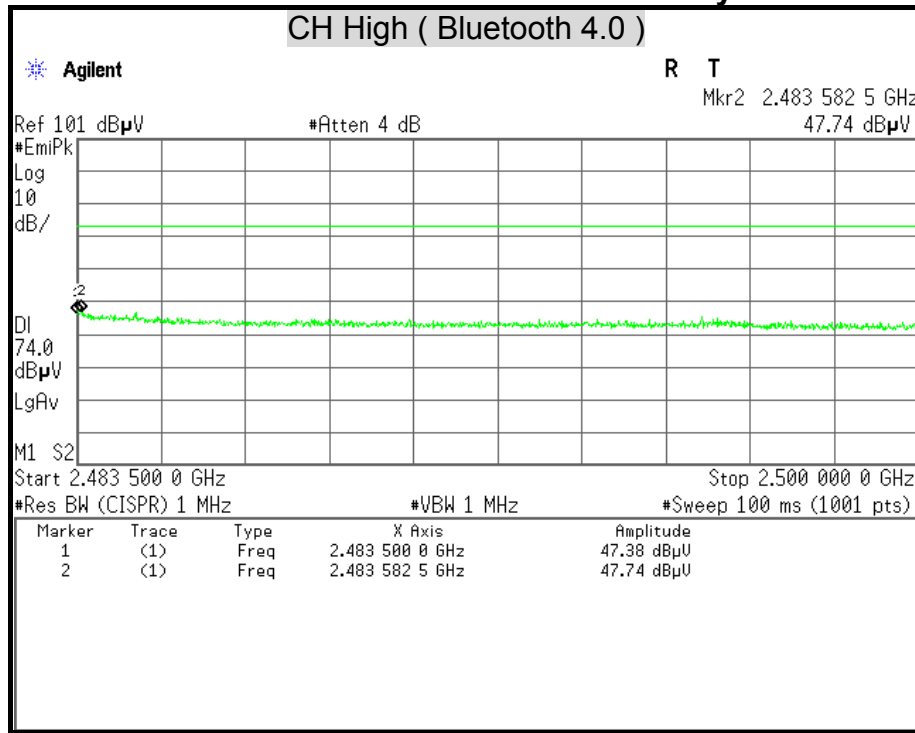

Detector Mode : Average

Polarity : Horizontal

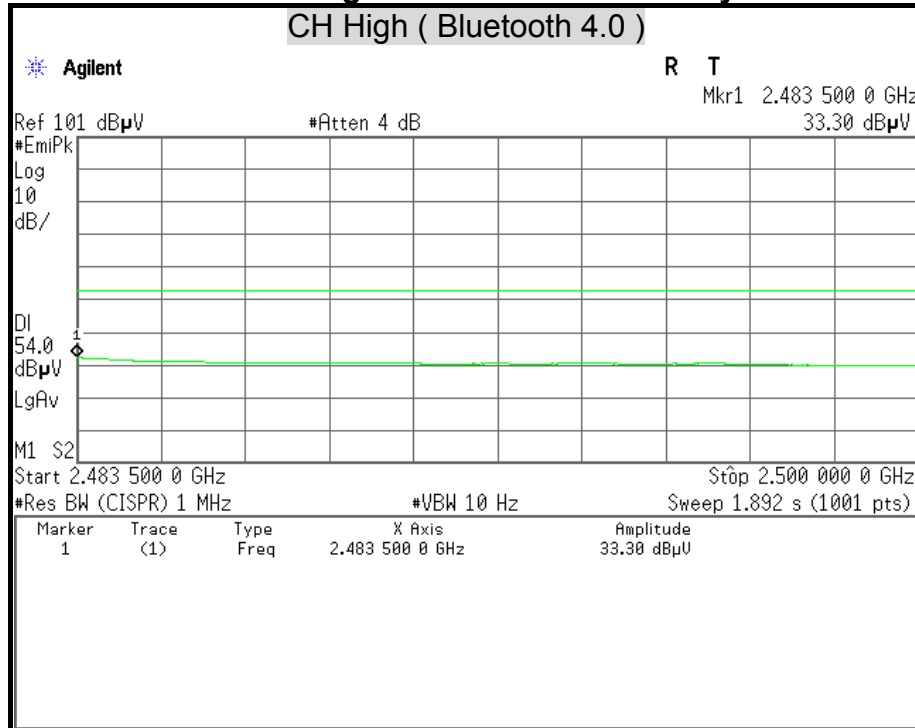



Detector Mode : Peak

Polarity : Vertical

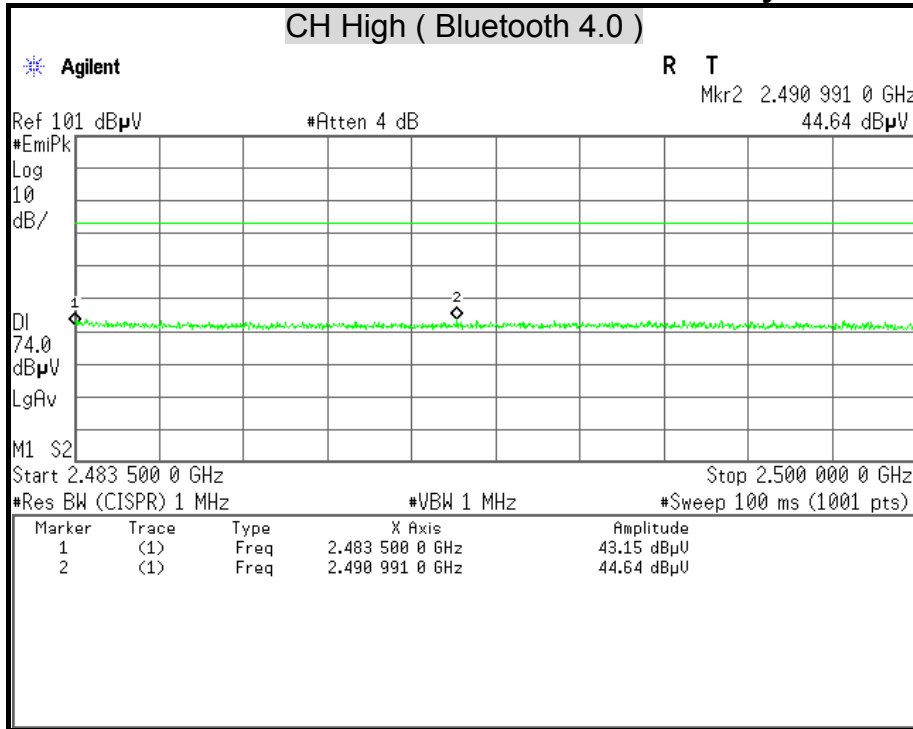

Detector Mode : Average

Polarity : Vertical

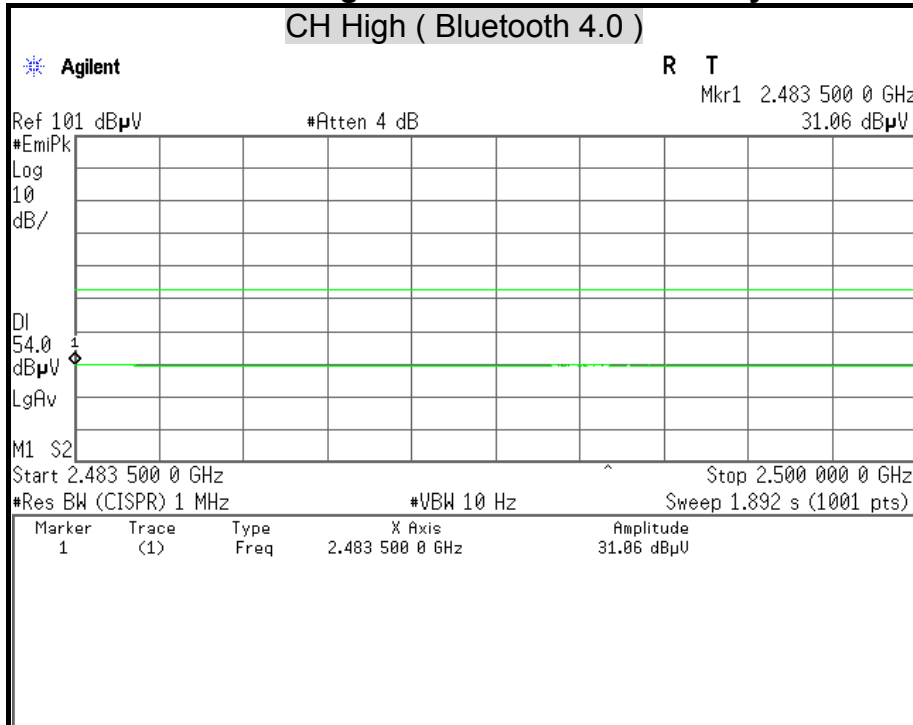



7.7 CONDUCTED EMISSION

LIMITS

§ 15.207 (a) Except as shown in paragraph (b) and (c) this section, for an intentional radiator that is designed to be connected to the public utility (AC) power line, the radio frequency voltage that is conducted back onto the AC power line on any frequency or frequencies within the band 150 kHz to 30 MHz shall not exceed the limits in the following table, as measured using a 50 μ H/50 ohms line impedance stabilization network (LISN). Compliance with the provisions of this paragraph shall be based on the measurement of the radio frequency voltage between each power line and ground at the power terminal. The lower limit applies at the boundary between the frequency ranges.

Frequency Range (MHz)	Conducted Limit (dB μ v)	
	Quasi-peak	Average
0.15 - 0.50	66 to 56	56 to 46
0.50 - 5.00	56	46
5.00 - 30.0	60	50

TEST EQUIPMENT

Name of Equipment	Manufacturer	Model	Serial Number	Calibration Due
L.I.S.N	SCHWARZBECK	NSLK 8127	8127-465	08/06/2015
L.I.S.N	SCHWARZBECK	NSLK 8127	8127-473	03/10/2015
EMI Receiver	ROHDE & SCHWARZ	ESHS 30	838550/003	11/02/2015
Pulse Limiter	ROHDE & SCHWARZ	ESH3-Z2	100111	06/30/2015

Remark: Each piece of equipment is scheduled for calibration once a year.



TEST SETUP

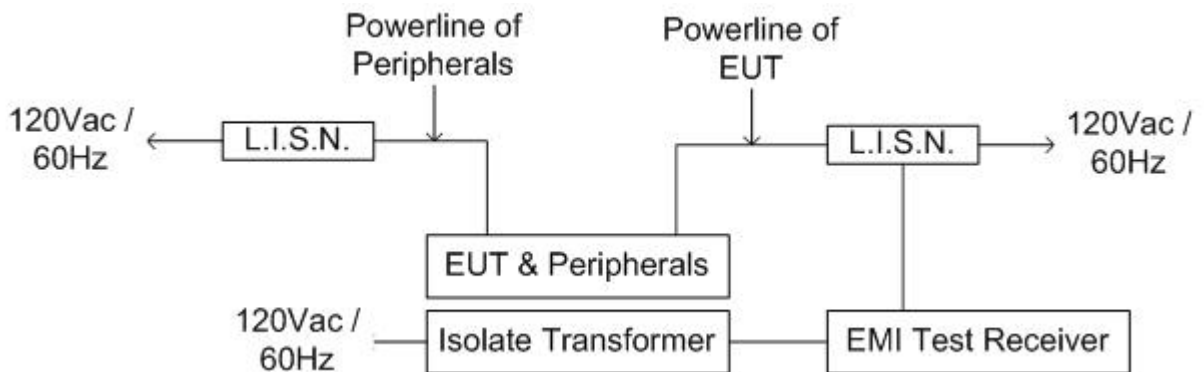
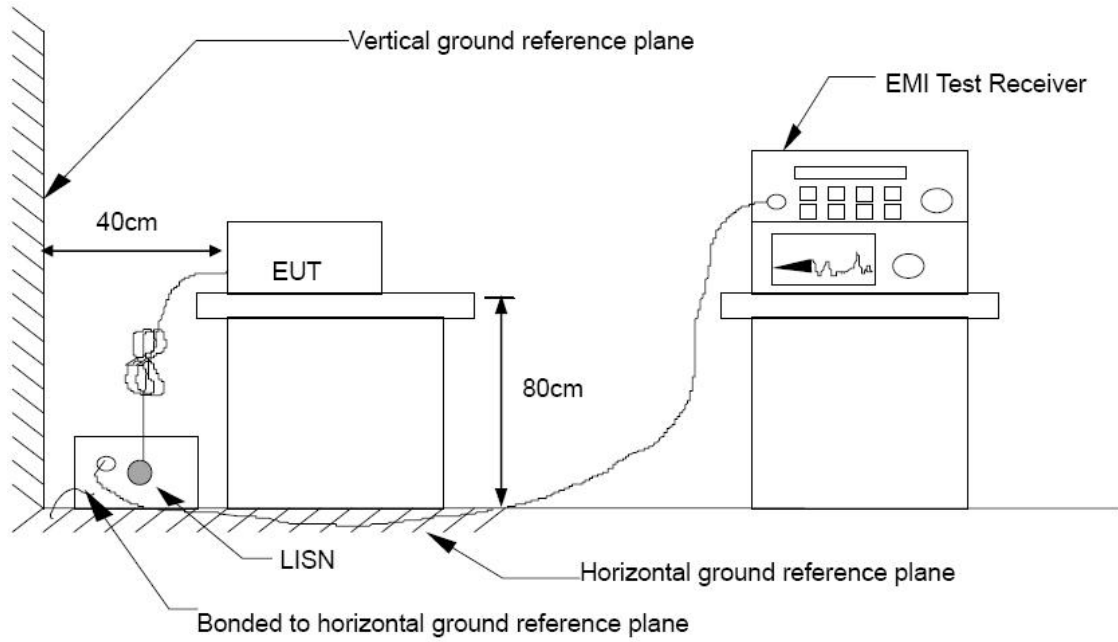



TEST PROCEDURE

The basic test procedure was in accordance with ANSI C63.10:2009.

The test procedure is performed in a 4m × 3m × 2.4m (L×W×H) shielded room.

The EUT along with its peripherals were placed on a 1.0m (W) × 1.5m (L) and 0.8m in height wooden table and the EUT was adjusted to maintain a 0.4 meter space from a vertical reference plane.

The EUT was connected to power mains through a line impedance stabilization network (LISN) which provides 50 ohm coupling impedance for measuring instrument and the chassis ground was bounded to the horizontal ground plane of shielded room. All peripherals were connected to the second LISN and the chassis ground also bounded to the horizontal ground plane of shielded room.

The EUT was located so that the distance between the boundary of the EUT and the closest surface of the LISN is 0.8 m. Where a mains flexible cord was provided by the manufacturer shall be 1 m long, or if in excess of 1 m, the excess cable was folded back and forth as far as possible so as to form a bundle not exceeding 0.4 m in length.

TEST RESULTS

Since the EUT is powered by DC Source, this test item is not applicable.