



**FCC 47 CFR PART 15 SUBPART C**

**TEST REPORT**

**For**

**Computer**

**Model: TREK-520; TREK-520XXXXXXXXXXXXXXXXXX;  
TREK520XXXXXXXXXXXXXXXXXX**  
(where "X" may be any alphanumeric character, "-", "\_" or blank)

**Trade Name: ADVANTECH**

*Issued to*

**Advantech Co. Ltd.  
No.1, Alley 20, Lane 26, Rueiguang Road, Neihu District, Taipei 114,  
Taiwan, R.O.C.**

*Issued by*

**Compliance Certification Services Inc.  
No.81-1, Lane 210, Bade 2nd Rd., Lujhu Township,  
Taoyuan County 33841, Taiwan, R.O.C.  
TEL: 886-3-324-0332  
FAX: 886-3-324-5235  
<http://www.ccsrf.com>  
[service@ccsrf.com](mailto:service@ccsrf.com)**



**Note:** *This report shall not be reproduced except in full, without the written approval of Compliance Certification Services Inc. This document may be altered or revised by Compliance Certification Services Inc. personnel only, and shall be noted in the revision section of the document. The client should not use it to claim product endorsement by TAF, A2LA, NIST or any government agencies. The test results in the report only apply to the tested sample.*



**Compliance Certification Services Inc.**

Report No.: T130822L04-RP2    FCC ID: M82-TREK520    Date of Issue: October 30, 2013

---

**Revision History**

Rev.	Issue Date	Revisions	Effect Page	Revised By
00	October 30, 2013	Initial Issue	All	Iren Wang



## TABLE OF CONTENTS

<b>1</b>	<b>TEST RESULT CERTIFICATION</b> .....	<b>4</b>
<b>2</b>	<b>EUT DESCRIPTION</b> .....	<b>5</b>
<b>3</b>	<b>TEST METHODOLOGY</b> .....	<b>6</b>
3.1.	EUT CONFIGURATION.....	6
3.2.	EUT EXERCISE.....	6
3.3.	GENERAL TEST PROCEDURES .....	6
3.4.	FCC PART 15.205 RESTRICTED BANDS OF OPERATIONS .....	7
3.5.	DESCRIPTION OF TEST MODES .....	8
<b>4</b>	<b>INSTRUMENT CALIBRATION</b> .....	<b>9</b>
4.1.	MEASUREMENT EQUIPMENT USED.....	9
4.2.	MEASUREMENT UNCERTAINTY .....	10
<b>5</b>	<b>FACILITIES AND ACCREDITATIONS</b> .....	<b>11</b>
5.1.	FACILITIES.....	11
5.2.	EQUIPMENT .....	11
5.3.	TABLE OF ACCREDITATIONS AND LISTINGS .....	12
<b>6</b>	<b>SETUP OF EQUIPMENT UNDER TEST</b> .....	<b>13</b>
6.1.	SETUP CONFIGURATION OF EUT .....	13
6.2.	SUPPORT EQUIPMENT .....	13
<b>7</b>	<b>FCC PART 15.247 REQUIREMENTS</b> .....	<b>14</b>
7.1.	20DB BANDWIDTH .....	14
7.2.	PEAK POWER.....	18
7.3.	AVERAGE POWER .....	20
7.4.	BAND EDGES MEASUREMENT.....	21
7.5.	FREQUENCY SEPARATION .....	35
7.6.	NUMBER OF HOPPING FREQUENCY.....	37
7.7.	TIME OF OCCUPANCY (DWELL TIME).....	40
7.8.	SPURIOUS EMISSIONS .....	52
7.9.	POWERLINE CONDUCTED EMISSIONS.....	66
<b>8</b>	<b>PHOTOGRAPHS OF TEST SETUP</b> .....	<b>67</b>
	<b>APPENDIX 1: PHOTOGRAPHS OF EUT</b> .....	<b>70</b>



# 1 TEST RESULT CERTIFICATION

**Applicant:**                                    **Advantech Co. Ltd.**  
 No.1, Alley 20, Lane 26, Rueiguang Road, Neihu District,  
 Taipei 114, Taiwan, R.O.C.

**Manufacturer:**                              **Advantech Co. Ltd.**  
 No.1, Alley 20, Lane 26, Rueiguang Road, Neihu District,  
 Taipei 114, Taiwan, R.O.C.

**Equipment Under Test:**    Computer

**Trade Name:**                                ADVANTECH

**Model:**                                        TREK-520; TREK-520XXXXXXXXXXXXXXXXXX;  
 TREK520XXXXXXXXXXXXXXXXXX (where "X" may be any  
 alphanumeric character, "-", "\_" or blank)

**Date of Test:**                                October 8, 2013

APPLICABLE STANDARDS	
STANDARD	TEST RESULT
FCC 47 CFR Part 15 Subpart C	No non-compliance noted

## We hereby certify that:

The above equipment was tested by Compliance Certification Services Inc. The test data, data evaluation, test procedures, and equipment configurations shown in this report were made in accordance with the procedures given in ANSI C63.4 and the energy emitted by the sample EUT tested as described in this report is in compliance with the requirements of FCC Rules Part 15.207, 15.209, 15.247.

The test results of this report relate only to the tested sample EUT identified in this report.

**Approved by:**

**Reviewed by:**

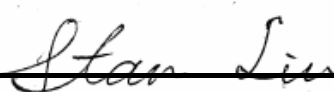
  
 \_\_\_\_\_  
 Stan Lin  
 Section Manager

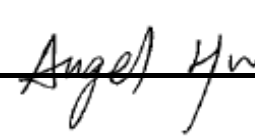
  
 \_\_\_\_\_  
 Angel Hu  
 Section Manager



## 2 EUT DESCRIPTION

<b>Product</b>	Computer
<b>Trade Name</b>	ADVANTECH
<b>Model Number</b>	TREK-520; TREK-520XXXXXXXXXXXXXXXXXX; TREK520XXXXXXXXXXXXXXXXXX (where "X" may be any alphanumeric character, "-", "_" or blank)
<b>Model Name Discrepancy</b>	N/A
<b>EUT Power Rating</b>	12-32VDC
<b>Operating Frequency Range</b>	2402 ~ 2480 MHz
<b>Transmit Power</b>	<b>For GFSK</b> 9.01dBm (0.0080W) <b>For 8DPSK</b> 8.71dBm (0.0074W)
<b>Modulation Technique</b>	GFSK; $\pi/4$ -DQPSK; 8DPSK
<b>Transmit Data Rate</b>	GFSK for 1Mbps; $\pi/4$ -DQPSK for 2Mbps; 8DPSK for 3Mbps
<b>Number of Channels</b>	79 Channels
<b>Antenna Specification</b>	Dipole Antenna / Gain: -3.03dBi

**Remark:**

1. The sample selected for test was production product and was provided by manufacturer.
2. This submittal(s) (test report) is intended for FCC ID: **M82-TREK520** filing to comply with Section 15.207, 15.209 and 15.247 of the FCC Part 15, Subpart C Rules.



### **3 TEST METHODOLOGY**

The tests documented in this report were performed in accordance with ANSI C63.4 (2009), DA00-705 and FCC CFR 47 15.207, 15.209 and 15.247.

#### **3.1. EUT CONFIGURATION**

The EUT configuration for testing is installed on RF field strength measurement to meet the Commissions requirement and operating in a manner that intends to maximize its emission characteristics in a continuous normal application.

#### **3.2. EUT EXERCISE**

The EUT was operated in the engineering mode to fix the TX frequency that was for the purpose of the measurements.

According to its specifications, the EUT must comply with the requirements of the Section 15.207, 15.209 and 15.247 under the FCC Rules Part 15 Subpart C.

#### **3.3. GENERAL TEST PROCEDURES**

##### **Conducted Emissions**

The EUT is placed on the turntable, which is 0.8 m above ground plane. According to the requirements in Section 13.1.4.1 of ANSI C63.4 Conducted emissions from the EUT measured in the frequency range between 0.15 MHz and 30MHz using CISPR Quasi-peak and average detector modes.

##### **Radiated Emissions**

The EUT is placed on a turn table, which is 0.8 m above ground plane. The turntable shall rotate 360 degrees to determine the position of maximum emission level. EUT is set 3m away from the receiving antenna, which varied from 1m to 4m to find out the highest emission. And also, each emission was to be maximized by changing the polarization of receiving antenna both horizontal and vertical. In order to find out the maximum emissions, exploratory radiated emission measurements were made according to the requirements in Section 13.1.4.1 of ANSI C63.4.



### 3.4. FCC PART 15.205 RESTRICTED BANDS OF OPERATIONS

(a) Except as shown in paragraph (d) of this section, only spurious emissions are permitted in any of the frequency bands listed below:

MHz	MHz	MHz	GHz
0.090 - 0.110	16.42 - 16.423	399.9 - 410	4.5 - 5.15
<sup>1</sup> 0.495 - 0.505	16.69475 - 16.69525	608 - 614	5.35 - 5.46
2.1735 - 2.1905	16.80425 - 16.80475	960 - 1240	7.25 - 7.75
4.125 - 4.128	25.5 - 25.67	1300 - 1427	8.025 - 8.5
4.17725 - 4.17775	37.5 - 38.25	1435 - 1626.5	9.0 - 9.2
4.20725 - 4.20775	73 - 74.6	1645.5 - 1646.5	9.3 - 9.5
6.215 - 6.218	74.8 - 75.2	1660 - 1710	10.6 - 12.7
6.26775 - 6.26825	108 - 121.94	1718.8 - 1722.2	13.25 - 13.4
6.31175 - 6.31225	123 - 138	2200 - 2300	14.47 - 14.5
8.291 - 8.294	149.9 - 150.05	2310 - 2390	15.35 - 16.2
8.362 - 8.366	156.52475 -	2483.5 - 2500	17.7 - 21.4
8.37625 - 8.38675	156.52525	2655 - 2900	22.01 - 23.12
8.41425 - 8.41475	156.7 - 156.9	3260 - 3267	23.6 - 24.0
12.29 - 12.293	162.0125 - 167.17	3332 - 3339	31.2 - 31.8
12.51975 - 12.52025	167.72 - 173.2	3345.8 - 3358	36.43 - 36.5
12.57675 - 12.57725	240 - 285	3600 - 4400	( <sup>2</sup> )
13.36 - 13.41	322 - 335.4		

<sup>1</sup> Until February 1, 1999, this restricted band shall be 0.490-0.510 MHz.

<sup>2</sup> Above 38.6

(b) Except as provided in paragraphs (d) and (e), the field strength of emissions appearing within these frequency bands shall not exceed the limits shown in Section 15.209. At frequencies equal to or less than 1000 MHz, compliance with the limits in Section 15.209 shall be demonstrated using measurement instrumentation employing a CISPR quasi-peak detector. Above 1000 MHz, compliance with the emission limits in Section 15.209 shall be demonstrated based on the average value of the measured emissions. The provisions in Section 15.35 apply to these measurements.



### **3.5. DESCRIPTION OF TEST MODES**

The EUT (model: TREK-520) had been tested under operating condition and had been reported as worst case on this test report.

Test program used to control the EUT for staying in continuous transmitting mode was programmed.

After Pre-Scan, 3Mbps is worst case, because 3Mbps output power > 2Mbps.

Following channel(s) was (were) selected for the final test as listed below.

<b>Tested Channel</b>	<b>Modulation Type</b>	<b>Packet Type</b>	<b>Date Rate</b>
Low, Mid, High	GFSK	DH 5	1
Low, Mid, High	8DPSK	DH 5	3

After verification, all tests were carried out with the worst case test modes as shown below except radiated spurious emission below 1GHz and power line conducted emissions below 30MHz, which worst case was in normal link mode only.

Channel Low (2402MHz), Mid (2441MHz) and High (2480MHz) with 1Mbps data rate was chosen for full testing.





## 4 INSTRUMENT CALIBRATION

The measuring equipment, which was utilized in performing the tests documented herein, has been calibrated in accordance with the manufacturer's recommendations for utilizing calibration equipment, which is traceable to recognized national standards.

### 4.1. MEASUREMENT EQUIPMENT USED

#### Equipment Used for Emissions Measurement

Conducted Emissions Test Site				
Name of Equipment	Manufacturer	Model	Serial Number	Calibration Due
Spectrum Analyzer	Agilent	E4446A	MY48250064	01/13/2014
Spectrum Analyzer	Agilent	N9010A	MY52220817	02/22/2014
Power meter	Anritsu	ML2495A	1033009	09/29/2014
Power Sensor	Anritsu	MA2411B	0917221	09/29/2014

3M Semi Anechoic Chamber				
Name of Equipment	Manufacturer	Model	Serial Number	Calibration Due
Spectrum Analyzer	Agilent	E4446A	MY48250064	01/13/2014
Pre-Amplifier	HP	8447D	2944A06530	04/23/2014
Pre-Amplifier	EMEC	EM01M26G	060570	07/25/2014
Pre-Amplifier	MITEQ	AMF-6F-26040 0-40-8P	985646	08/08/2014
Pre-Amplifier	Agilent	8449B	3008A01738	04/23/2014
EMI Test Receiver	SCHAFFNER	SCR 3501	430	03/24/2014
Loop Antenna	EMCO	6502	2356	06/12/2014
Bilog Antenna	TESEQ	CBL 6112D	35378	09/11/2014
Horn Antenna	EMCO	3115	00022250	08/04/2014
Horn Antenna	EMCO	3116	00026370	01/07/2014
Antenna Tower	CCS	CC-A-1F	N/A	N.C.R
Test S/W	EZ-EMC			

**NOTE:** 1. The calibration interval of the above test instruments is 12 months and the calibrations are traceable to NML/ROC and NIST/USA.  
 2. N.C.R = No Calibration Request.



## 4.2. MEASUREMENT UNCERTAINTY

For the test methods, according to the present document, the measurement uncertainty figures shall be calculated in accordance with TR 100 028-1 [2] and shall correspond to an expansion factor (coverage factor)  $k = 1,96$  or  $k = 2$  (which provide confidence levels of respectively 95 % and 95,45 % in the case where the distributions characterizing the actual measurement uncertainties are normal (Gaussian)).

Table 6 is based on such expansion factors.

**Table 6: Maximum measurement uncertainty**

Parameter	Uncertainty
Powerline Conducted Emission	N/A
3M Semi Anechoic Chamber / 30MHz ~ 200MHz	$\pm 3.5921$
3M Semi Anechoic Chamber / 200MHz ~ 1GHz	$\pm 3.5657$
3M Semi Anechoic Chamber / 1 ~ 8GHz	$\pm 2.5873$
3M Semi Anechoic Chamber / 8 ~ 18GHz	$\pm 2.6646$
3M Semi Anechoic Chamber / 18 ~ 26GHz	$\pm 2.9617$
3M Semi Anechoic Chamber / 26 ~ 40GHz	$\pm 3.4250$

**Remark:** This uncertainty represents an expanded uncertainty expressed at approximately the 95% confidence level using a coverage factor of  $k=2$ .



## **5 FACILITIES AND ACCREDITATIONS**

### **5.1. FACILITIES**

All measurement facilities used to collect the measurement data are located at

- No.199, Chunghsen Road, Hsintien City, Taipei Hsien, Taiwan, R.O.C.  
Tel: 886-2-2217-0894 / Fax: 886-2-2217-1029
  
- No.11, Wugong 6th Rd., Wugu Industrial Park, Taipei Hsien 248, Taiwan  
Tel: 886-2-2299-9720 / Fax: 886-2-2298-4045
  
- No.81-1, Lane 210, Bade 2nd Rd., Lujhu Township, Taoyuan County 33841, Taiwan, R.O.C.  
Tel: 886-3-324-0332 / Fax: 886-3-324-5235

The sites are constructed in conformance with the requirements of ANSI C63.7, ANSI C63.4 and CISPR Publication 22.

### **5.2. EQUIPMENT**

Radiated emissions are measured with one or more of the following types of linearly polarized antennas: tuned dipole, biconical, log periodic, bi-log, and/or ridged waveguide, horn. Spectrum analyzers with pre-selectors and quasi-peak detectors are used to perform radiated measurements.





Conducted emissions are measured with Line Impedance Stabilization Networks and EMI Test Receivers.

Calibrated wideband preamplifiers, coaxial cables, and coaxial attenuators are also used for making measurements.

All receiving equipment conforms to CISPR Publication 16-1, "Radio Interference Measuring Apparatus and Measurement Methods."



**5.3. TABLE OF ACCREDITATIONS AND LISTINGS**

Country	Agency	Scope of Accreditation	Logo
USA	A2LA	CFR 47, FCC Part15/18, CISPR 22, EN 55022, ICES-003, AS/NZS CISPR 22, VCCI V-3, EN 55011, CISPR 11, IEC/EN 61000-4-2/3/4/5/6/8/11, EN 61000-6-1/2/3/4, EN 55024, CISPR 24, AS/NZS CISPR 24, AS/NZS 61000.6.2, EN 55014-1/-2, ETSI EN 300 386 v1.3.2/v1.3.3, IEC/EN 61000-3-2, AS/NZS 61000.3.2, IEC/EN 61000-3-3, AS/NZS 61000.3.3	 TESTING CERT #0824.01
USA	FCC MRA	3 meter Open Area Test Sites to perform FCC Part 15/18 measurements	
Japan	VCCI	3/10 meter Open Area Test Sites and conducted test sites to perform radiated/conducted measurements	<b>VCCI</b> R-2882/2541/2798/725/1868 C-402/747/912 T-1930/1646
Taiwan	TAF	EN 55014-1, CISPR 14, CNS 13781-1, EN 55013, CISPR 13, CNS 13439, EN 55011, CISPR 11, CNS 13803, PLMN09, IS2045-0, LP0002 FCC Part 27/90, Part 15B/C/D/E, RSS-192/193/210/310 ETSI EN 300 328/ 300 220-1/ 300 220-2/ 301 893/ 301 489-01/ 301 489-03/ 301 489-07 / 301 489-17/ 300 440-1/ 300 440-2 AS/NZS 4268, AS/NZS 4771 CISPR 22, EN 55022, CNS 13438, AS/NZS CISPR 22, VCCI, IEC/EN 61000-4-2/3/4/5/6/8/11, CNS 14676-2/3/4/5/6/8, CNS 14934-2/3, CNS 13783-1, CNS 13439, CNS 13803	
Taiwan	BSMI	CNS 13438, CNS 13783-1, CNS 13439, CNS 14115	SL2-IS-E-0014 / IN-E-0014 /A1-E-0014 /R1-E-0014 /R2-E-0014 /L1-E-0014
Canada	Industry Canada	RSS-Gen Issue 3	

**Note:** No part of this report may be used to claim or imply product endorsement by A2LA, TAF or other government agency.



## 6 SETUP OF EQUIPMENT UNDER TEST

### 6.1. SETUP CONFIGURATION OF EUT

See test photographs attached in Appendix 1 for the actual connections between EUT and support equipment.

### 6.2. SUPPORT EQUIPMENT

#### For Conducted Emissions and Radiated Emissions(Above 1GHz)

No.	Device Type	Brand	Model	Series No.	FCC ID	Data Cable	Power Cord
1	7" LCD Display	ADVANTECH	TREK-303	N/A	N/A	GPIB Cable: Shielded, 1.8m With two cores	N/A

#### For Radiated Emissions(Below 1GHz)

No.	Device Type	Brand	Model	Series No.	FCC ID	Data Cable	Power Cord
1	7" LCD Display	ADVANTECH	TREK-303	N/A	N/A	GPIB Cable: Shielded, 1.8m With two cores	N/A
2	Notebook Computer	TP00013A	LR-9XH2K	FCC DOC	LENOVO	USB Cable: Unshielded, 1.8m	AC I/P: Unshielded, 1.8m DC O/P: Unshielded, 1.8m with a core
3	Modem	ACEEX	DM-1414	304012261	IFAXDM1414	Unshielded, 1.8m	Shielded, 1.8m
4	Earphone	Logitech	ClearChat	N/A	N/A	Unshielded, 1.8m	N/A
5	USB Mouse	HP	MO19UCA	020440953	FCC DoC	Unshielded, 1.8m	N/A

**Remark:** Grounding was established in accordance with the manufacturer's requirements and conditions for the intended use.



## **7 FCC PART 15.247 REQUIREMENTS**

### **7.1. 20DB BANDWIDTH**

#### **LIMIT**

None; for reporting purposes only.

#### **TEST CONFIGURATION**

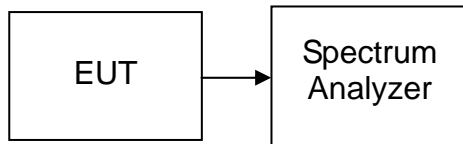

#### **TEST PROCEDURE**

1. Place the EUT on the table and set it in the transmitting mode.
2. Remove the antenna from the EUT and then connect a low loss RF cable from the antenna port to the spectrum analyzer.
3. Set the spectrum analyzer as RBW=30kHz, VBW = 100kHz, Span = 3MHz, Sweep = auto.
4. Set the spectrum analyzer as RBW=30kHz, VBW = 100kHz, Span = 3MHz, Sweep = auto.
5. Mark the peak frequency and 20dB (upper and lower) frequency.
6. Repeat until all the rest channels are investigated.

#### **TEST RESULTS**

*No non-compliance noted*



**Test Plot**

**GFSK**

**CH Low**

Agilent

R T

Mkr1 930 kHz  
-1.31 dB

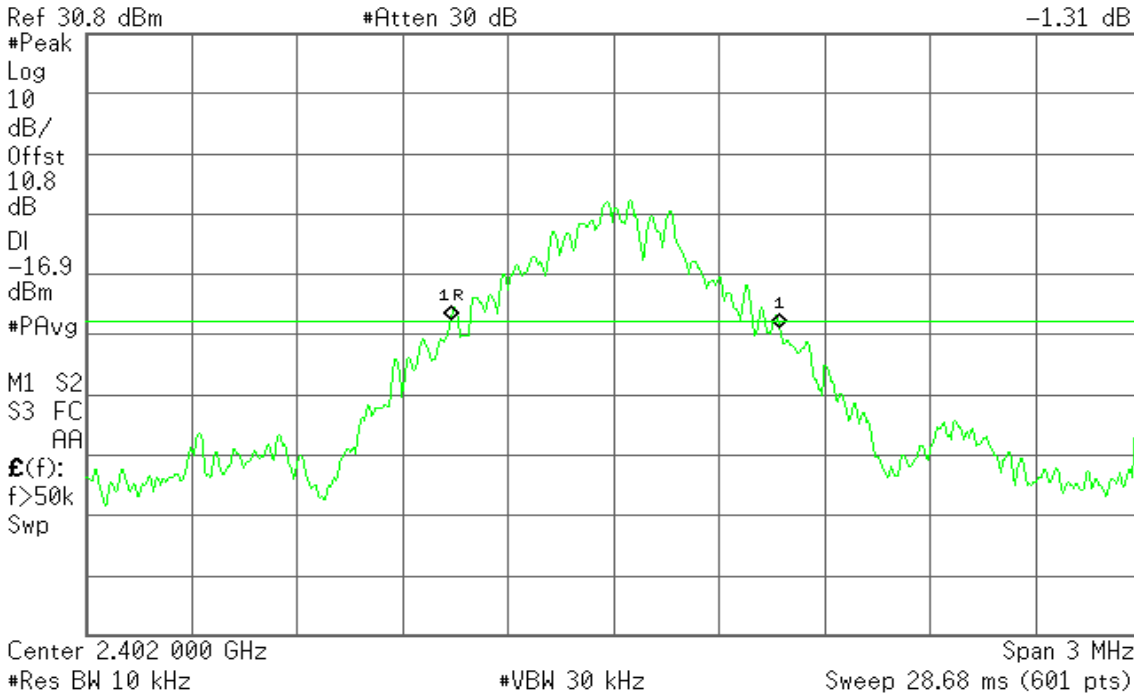

**CH Mid**

Agilent

R T

Mkr1 930 kHz  
-0.66 dB

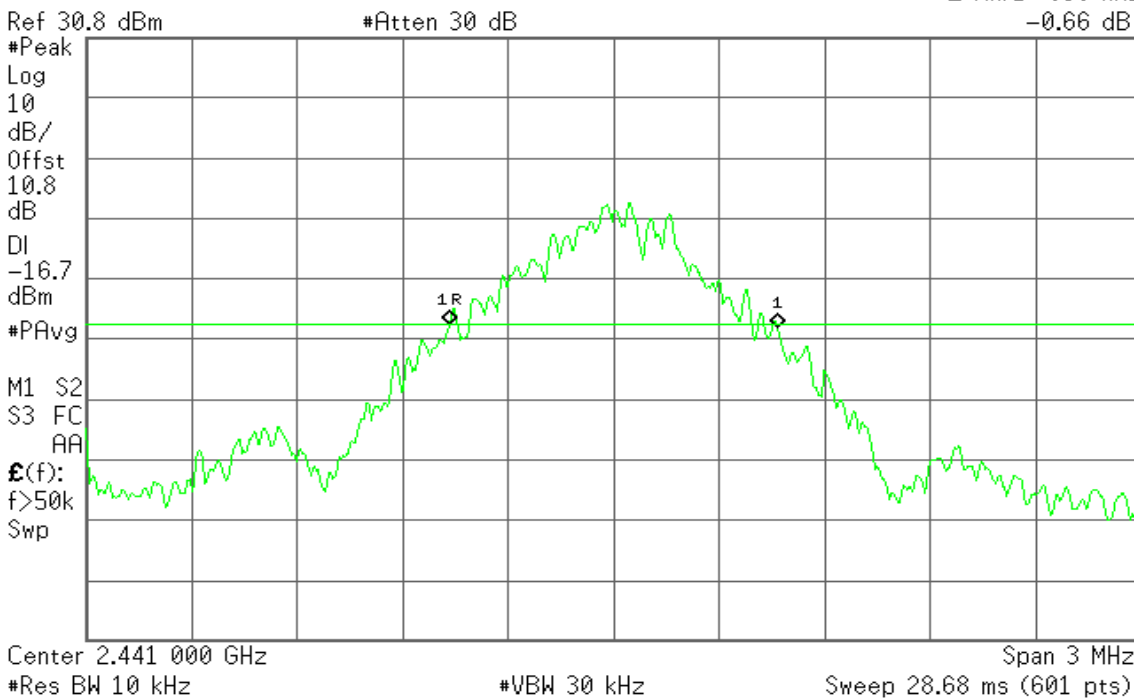



### CH High

Agilent

R T

Mkr1 930 kHz  
-0.60 dB

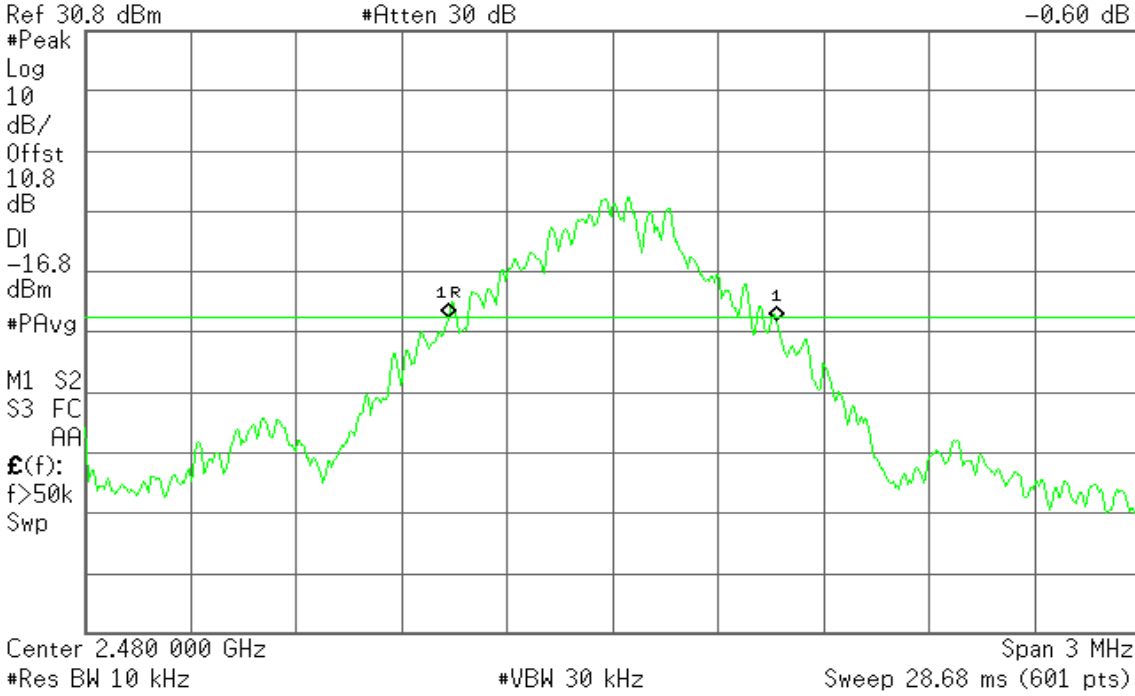

### 8DPSK

### CH Low

Agilent

R T

Mkr1 1.290 MHz  
0.04 dB

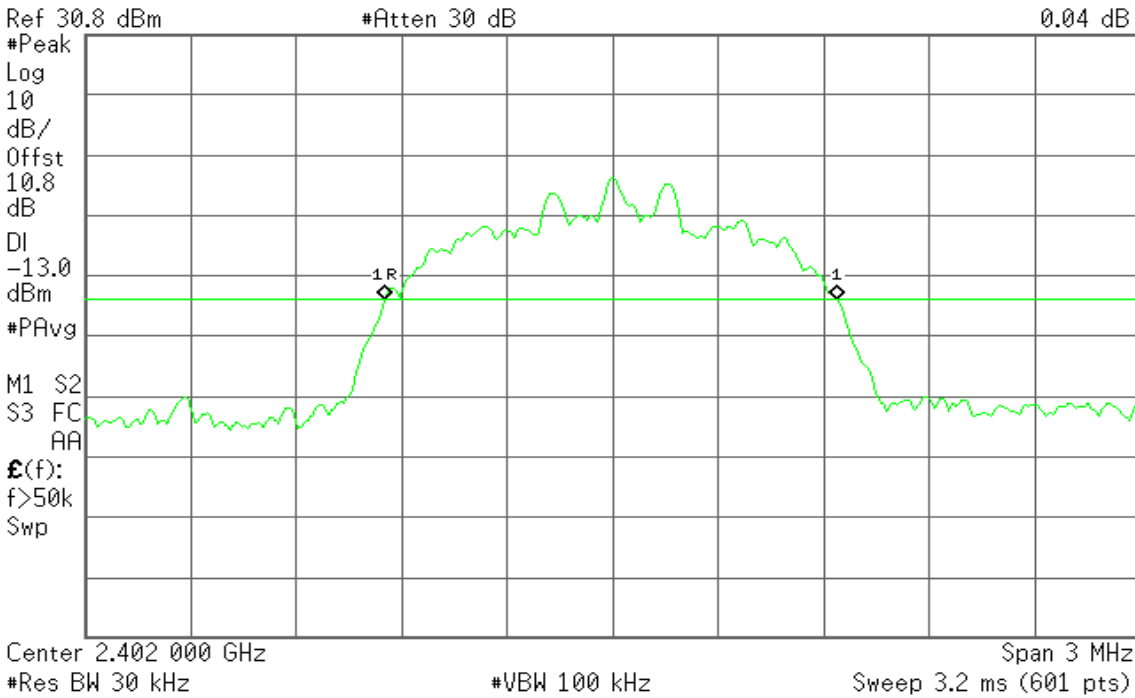





### CH Mid

Agilent

R T

Mkr1 1.290 MHz  
0.33 dB

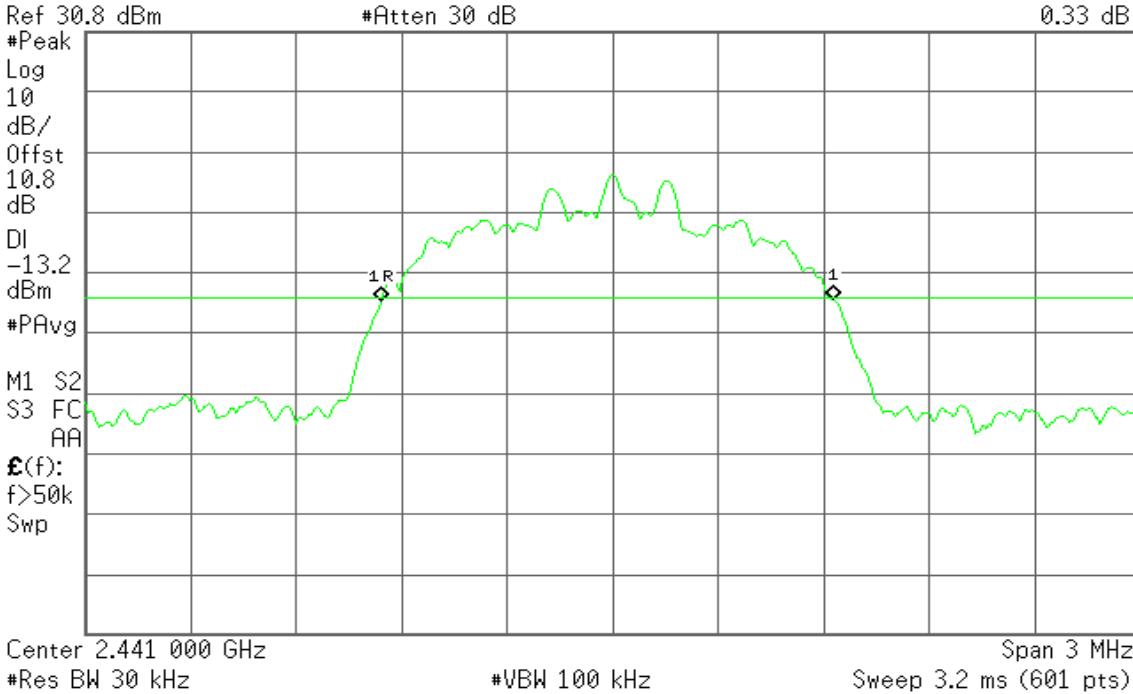

### CH High

Agilent

R T

Mkr1 1.290 MHz  
0.23 dB

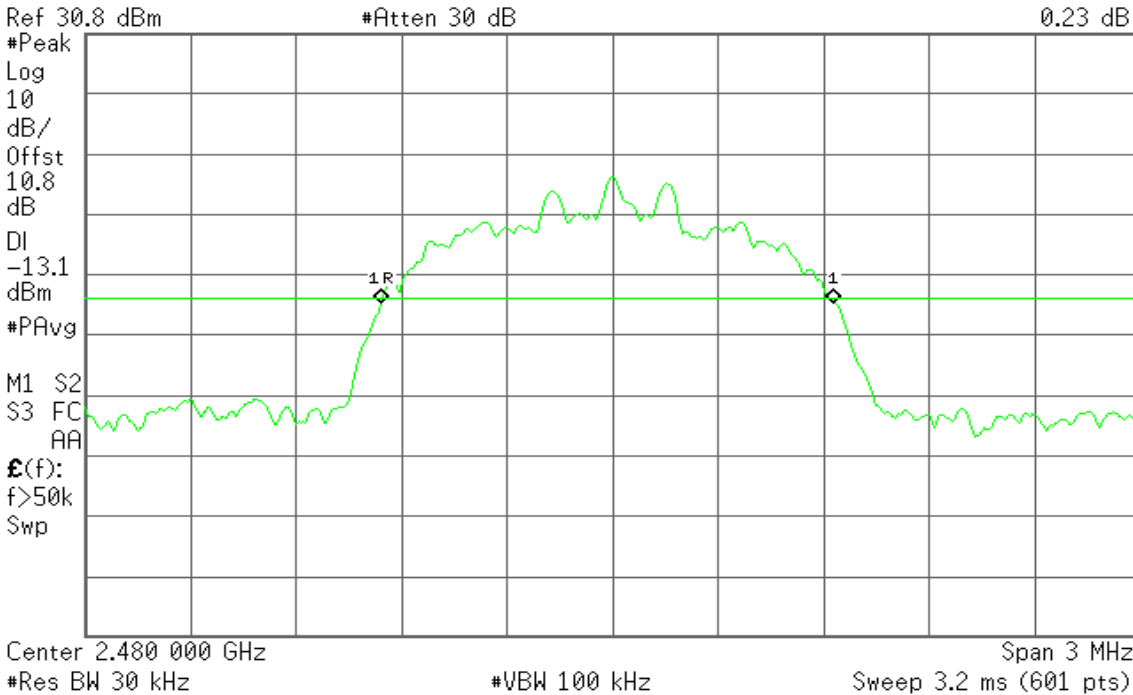



## **7.2. PEAK POWER**

### **LIMIT**

According to §15.247, the maximum peak output power of the intentional radiator shall not exceed the following:

1. According to §15.247(b)(3), for systems using digital modulation in the bands of 902-928 MHz, 2400-2483.5 MHz, and 5725-5850 MHz: 1 watt.
2. According to §15.247(b) (4), the conducted output power limit specified in paragraph (b) of this section is based on the use of antennas with directional gains that do not exceed 6 dBi. Except as shown in paragraph (c) of this section, if transmitting antennas of directional gain greater than 6 dBi are used, the conducted output power from the intentional radiator shall be reduced below the stated values in paragraphs (b)(1), (b)(2), and (b)(3) of this section, as appropriate, by the amount in dB that the directional gain of the antenna exceeds 6 dBi.

### **TEST CONFIGURATION**

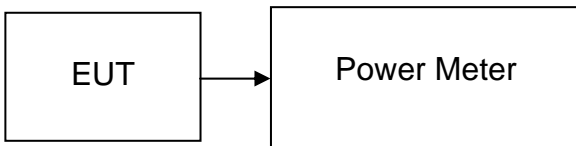

### **TEST PROCEDURE**

The transmitter output is connected to the Power Meter. The Power Meter is set to the peak power detection.

### **TEST RESULTS**

*No non-compliance noted*



## **TEST DATA**

### **GFSK**

<b>Channel</b>	<b>Frequency (MHz)</b>	<b>Output Power (dBm)</b>	<b>Output Power (W)</b>	<b>Limit (W)</b>	<b>Test Result</b>
Low	2402	8.81	0.0076	0.125	PASS
Mid	2441	9.01	0.0080		PASS
High	2480	8.88	0.0077		PASS

### **8DPSK**

<b>Channel</b>	<b>Frequency (MHz)</b>	<b>Output Power (dBm)</b>	<b>Output Power (W)</b>	<b>Limit (W)</b>	<b>Test Result</b>
Low	2402	8.55	0.0072	0.125	PASS
Mid	2441	8.71	0.0074		PASS
High	2480	8.63	0.0073		PASS



### **7.3. AVERAGE POWER**

#### **LIMIT**

None; for reporting purposes only.

#### **TEST CONFIGURATION**

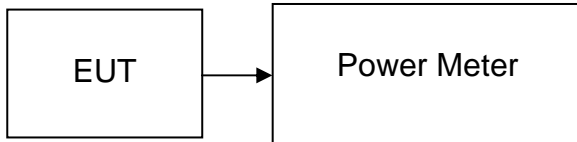

#### **TEST PROCEDURE**

The transmitter output is connected to the Power Meter. The Power Meter is set to the average power detection.

#### **TEST RESULTS**

*No non-compliance noted*

#### **TEST DATA**

##### **GFSK**

Channel	Frequency (MHz)	Output Power (dBm)	Output Power (W)
Low	2402	7.31	0.0054
Mid	2441	7.50	0.0056
High	2480	7.39	0.0055

##### **8DPSK**

Channel	Frequency (MHz)	Output Power (dBm)	Output Power (W)
Low	2402	5.59	0.0036
Mid	2441	5.60	0.0036
High	2480	5.30	0.0034



## 7.4. BAND EDGES MEASUREMENT

### LIMIT

According to §15.247(d), in any 100 kHz bandwidth outside the frequency band in which the spread spectrum or digitally modulated intentional radiator is operating, the radio frequency power that is produced by the intentional radiator shall be at least 20 dB below that in the 100 kHz bandwidth within the band that contains the highest level of this paragraph shall be 30 dB instead of 20 dB. Attenuation below the general limits specified in Section 15.209(a) is not required. In addition, radiated emissions which fall in the restricted bands, as defined in Section 15.205(a), must also comply with the radiated emission limits specified in Section 15.209(a) (see Section 15.205(c)).

### TEST CONFIGURATION

#### For Radiated

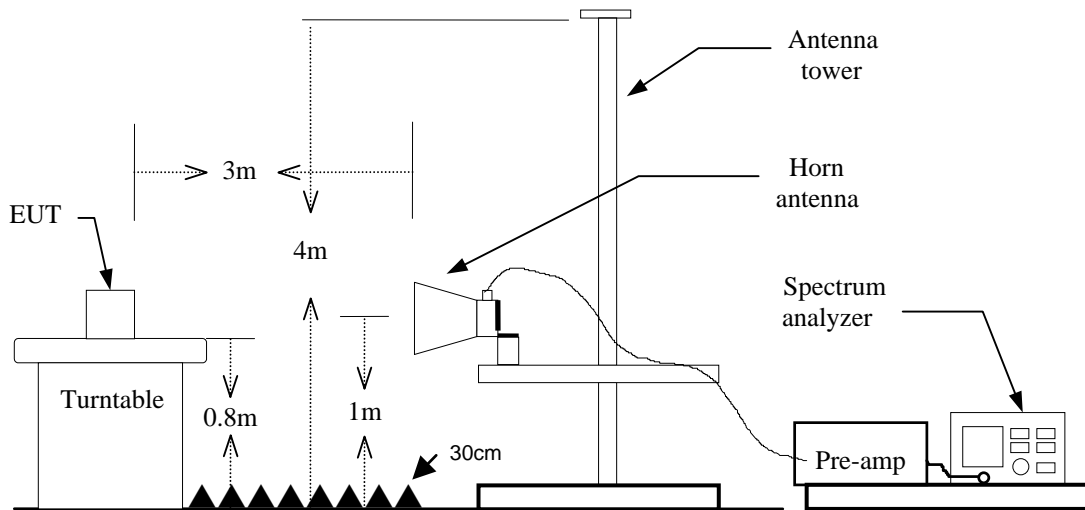

#### For Conducted

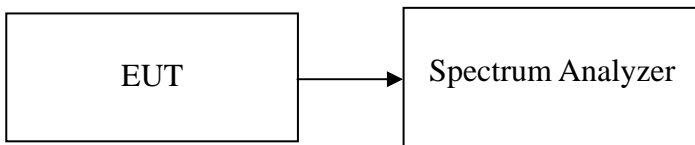



## **TEST PROCEDURE**

### **For Radiated**

1. The EUT is placed on a turntable, which is 0.8m above the ground plane.
2. The turntable shall be rotated for 360 degrees to determine the position of maximum emission level.
3. EUT is set 3m away from the receiving antenna, which is varied from 1m to 4m to find out the highest emission.
4. Set the spectrum analyzer in the following setting in order to capture the lower and upper band-edges of the emission:
  - (a) PEAK:RBW=1MHz VBW=RBW\*3 / Sweep=100ms
  - (b) AVERAGE: RBW=1MHz / VBW=300Hz / Sweep=AUTO
5. Repeat the procedures until all the PEAK and AVERAGE versus POLARIZATION are measured.

### **For Conducted**

Conducted RF measurements of the transmitter output were made to confirm that the EUT antenna port conducted emissions meet the specified limit and to identify any spurious signals that require further investigation or measurements on the radiated emissions site.

The transmitter output is connected to the spectrum analyzer. The resolution bandwidth is set to 100 kHz. The video bandwidth is set to 100 kHz.

## **TEST RESULTS**

*No non-compliance noted*

## **TEST DATA**

Refer to attach spectrum analyzer data chart.



**GFSK**

**CH Low**

**Detector mode: Peak**

**Polarity: Vertical**

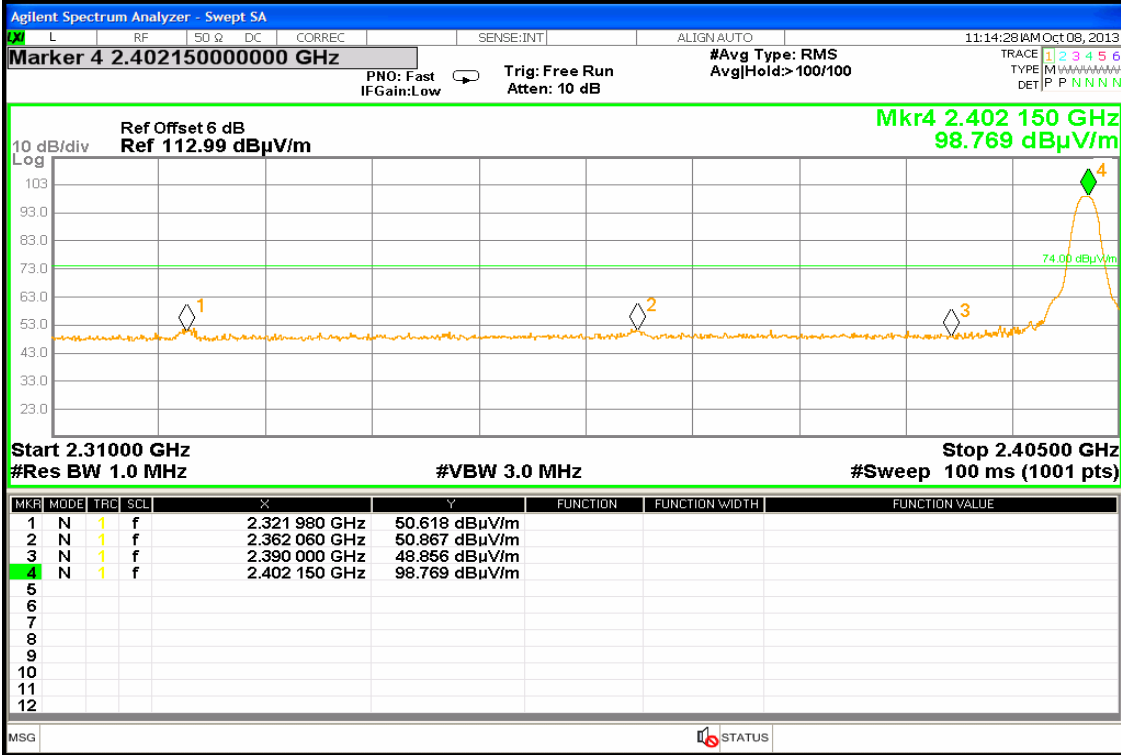

**Detector mode: Average**

**Polarity: Vertical**

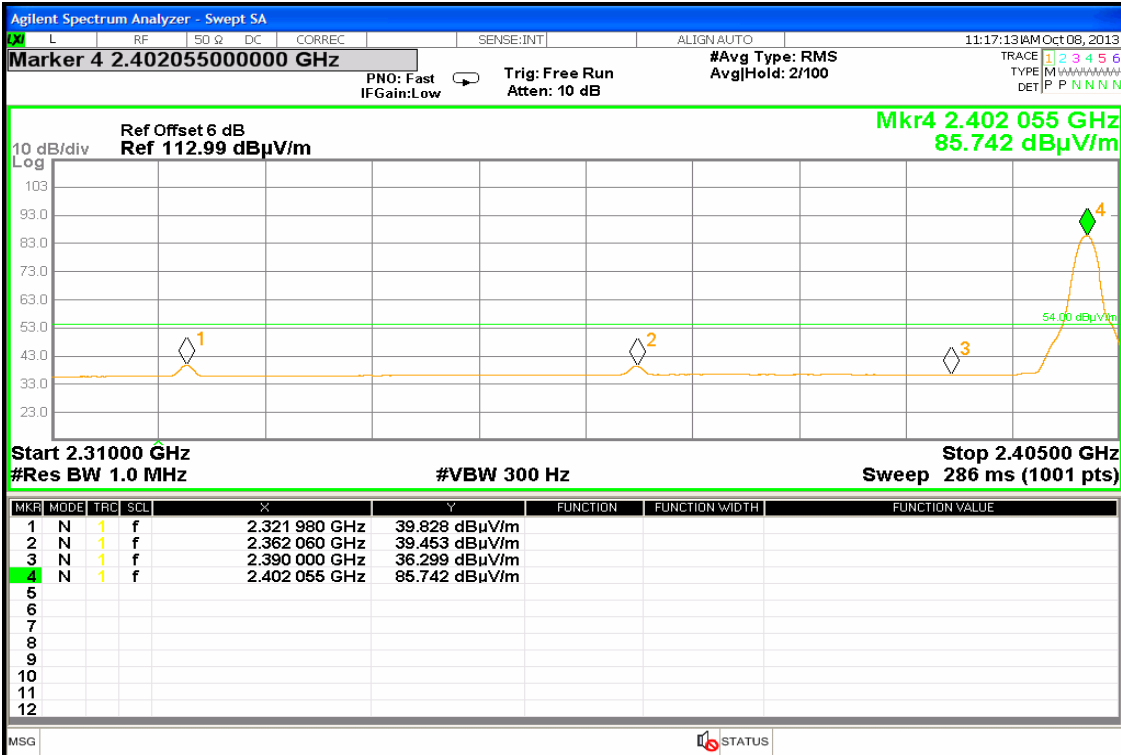



**Detector mode: Peak**

**Polarity: Horizontal**

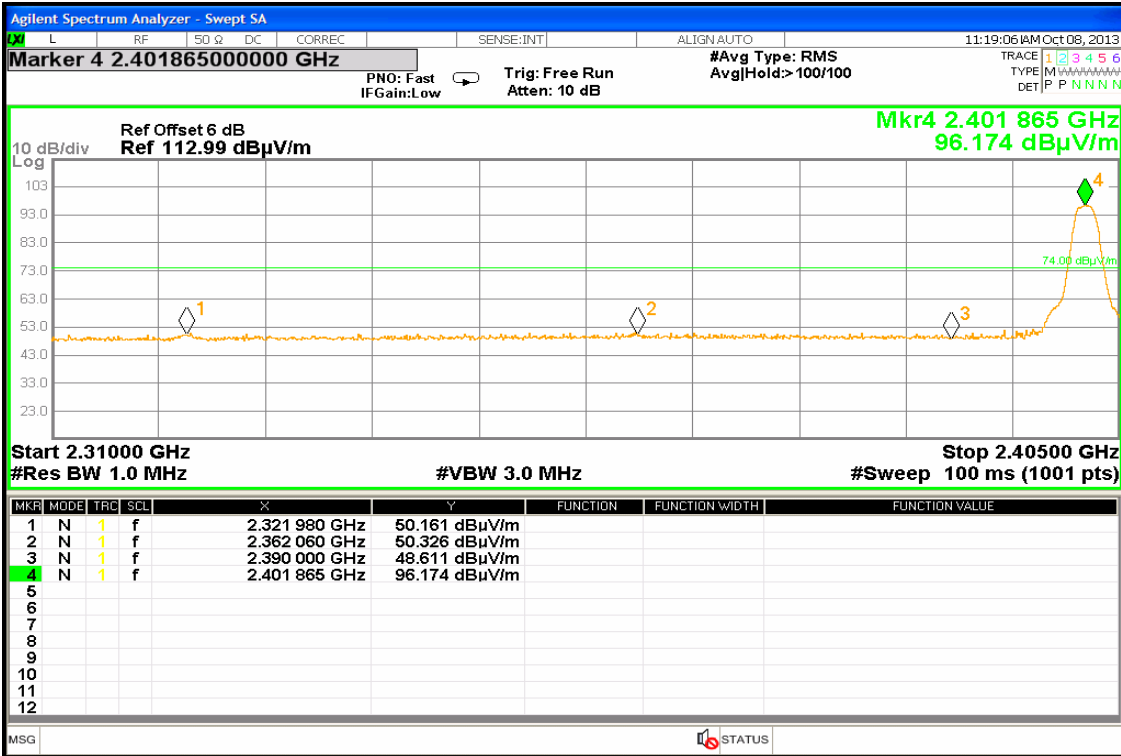

**Detector mode: Average**

**Polarity: Horizontal**

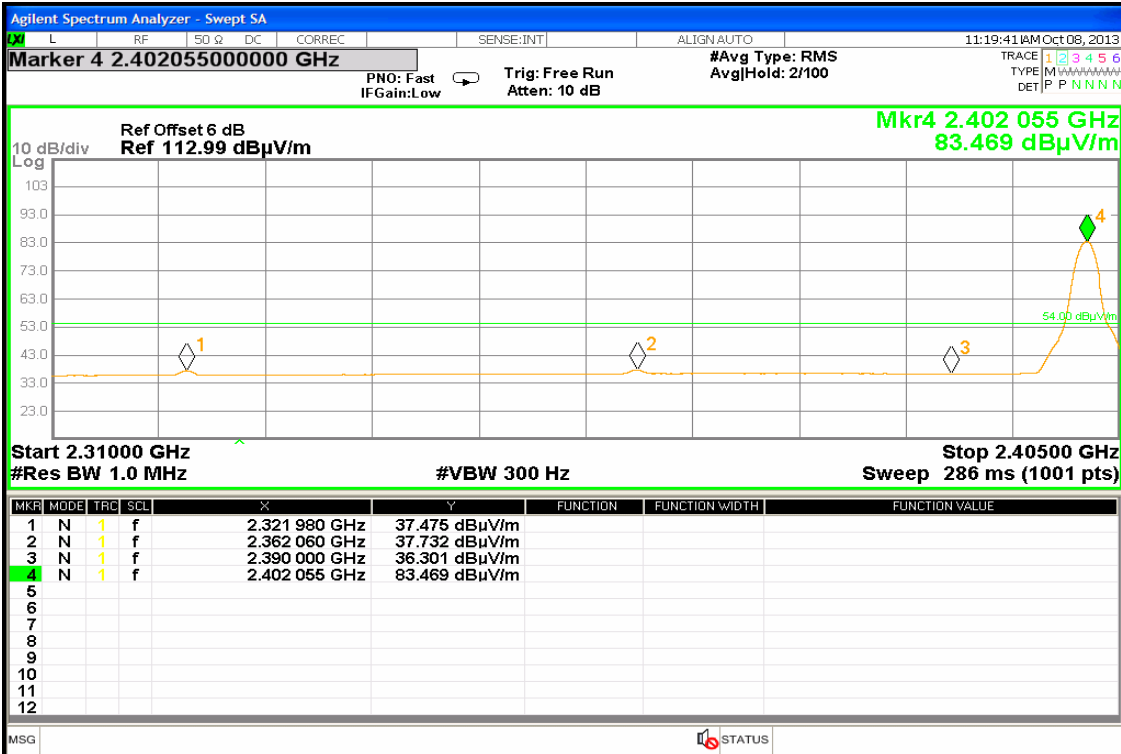





CH High

Detector mode: Peak

Polarity: Vertical

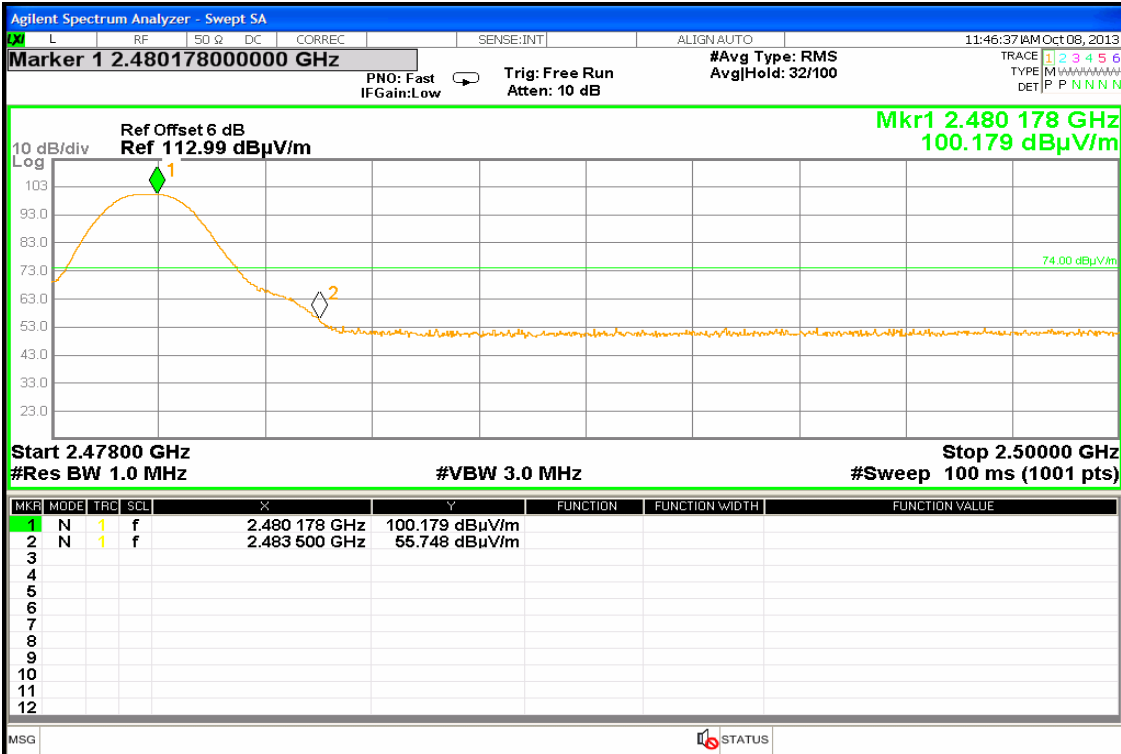

Detector mode: Average

Polarity: Vertical

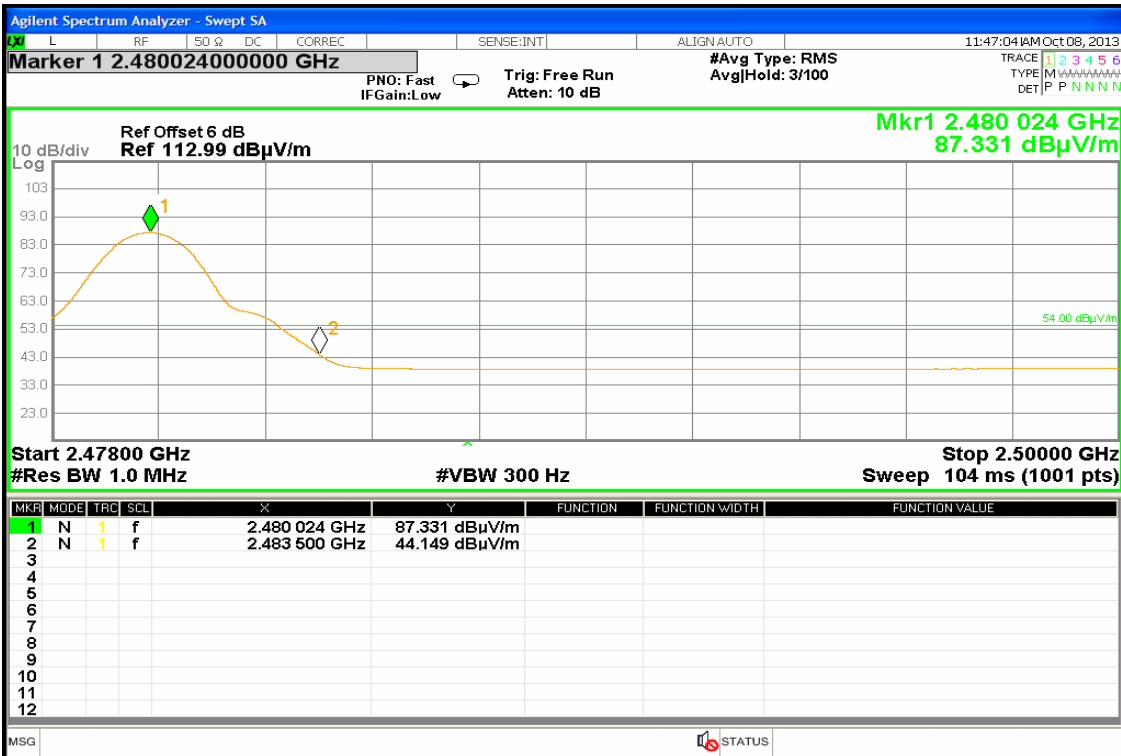



**Detector mode: Peak**

**Polarity: Horizontal**

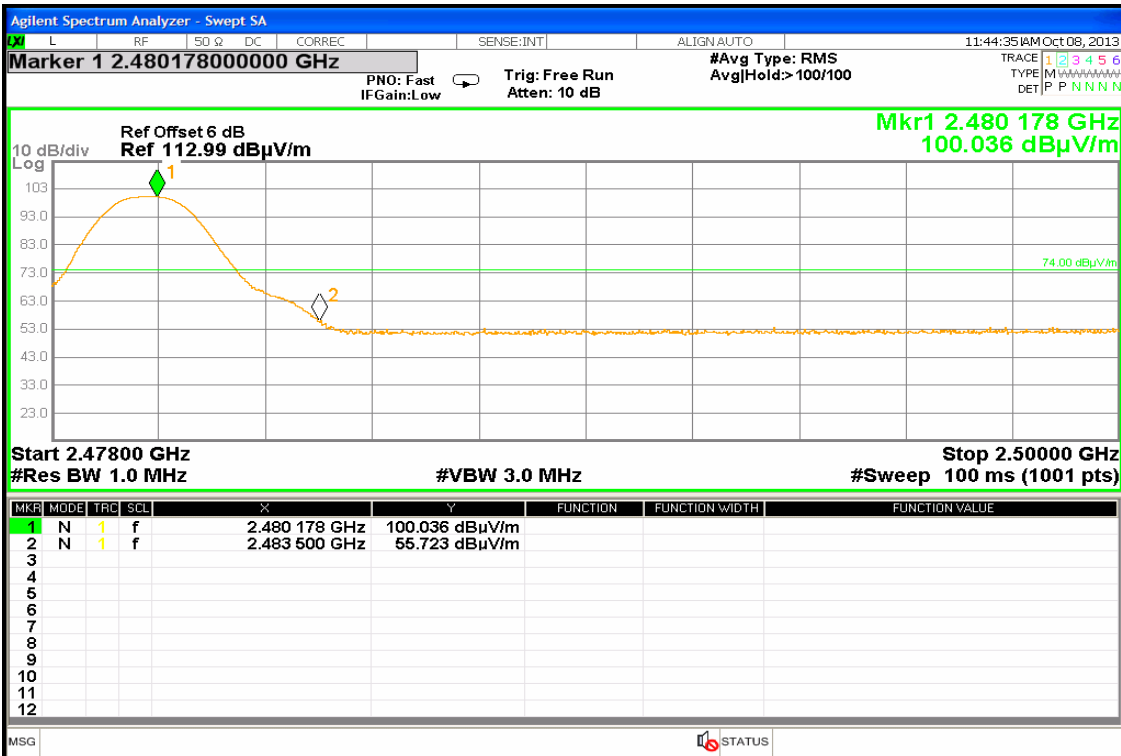

**Detector mode: Average**

**Polarity: Horizontal**

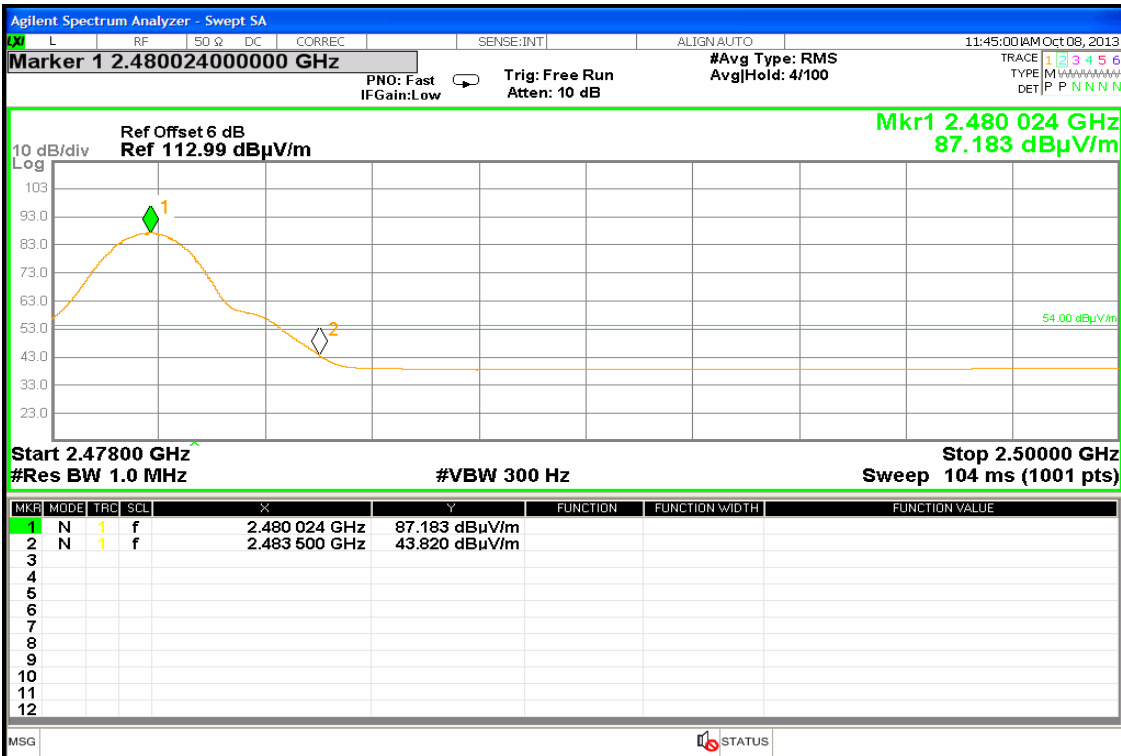



**8DPSK**

**CH Low**

**Detector mode: Peak**

**Polarity: Vertical**

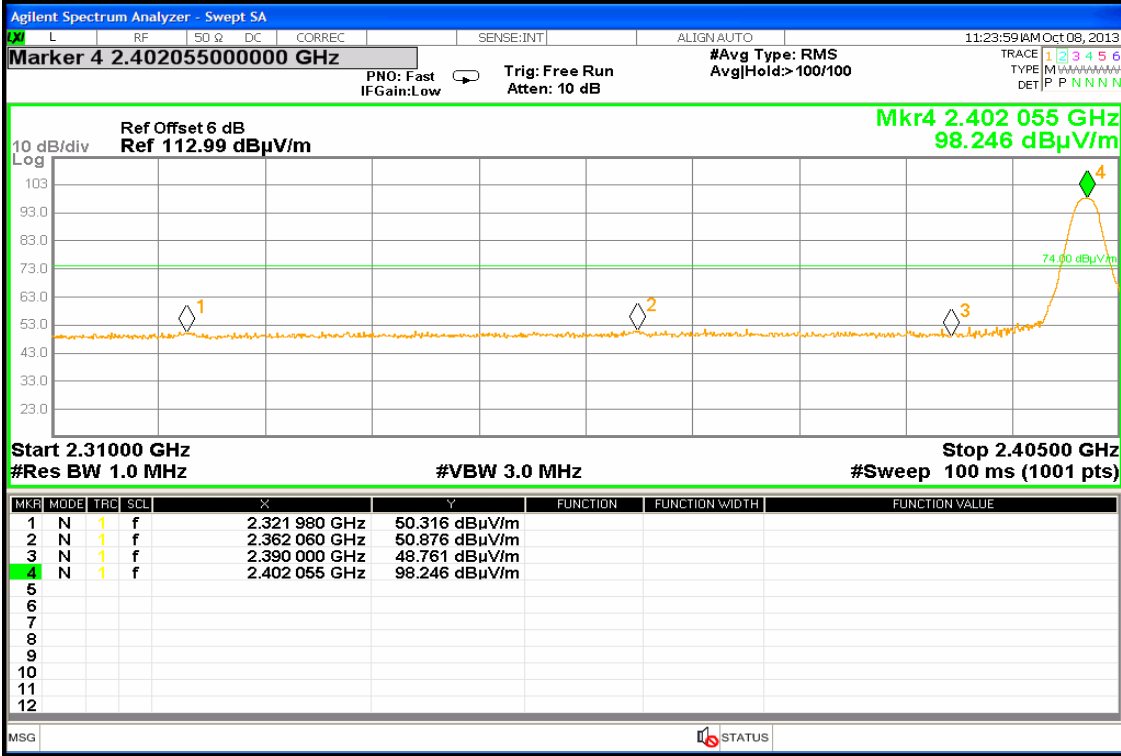

**Detector mode: Average**

**Polarity: Vertical**

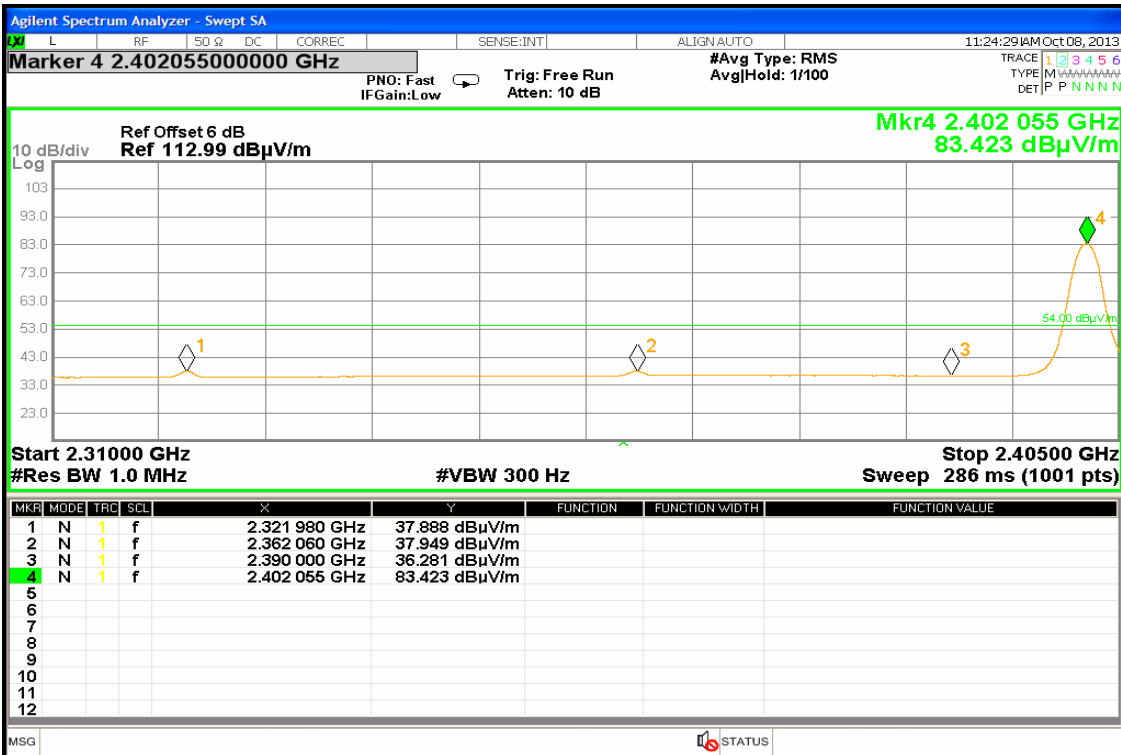



**Detector mode: Peak**

**Polarity: Horizontal**

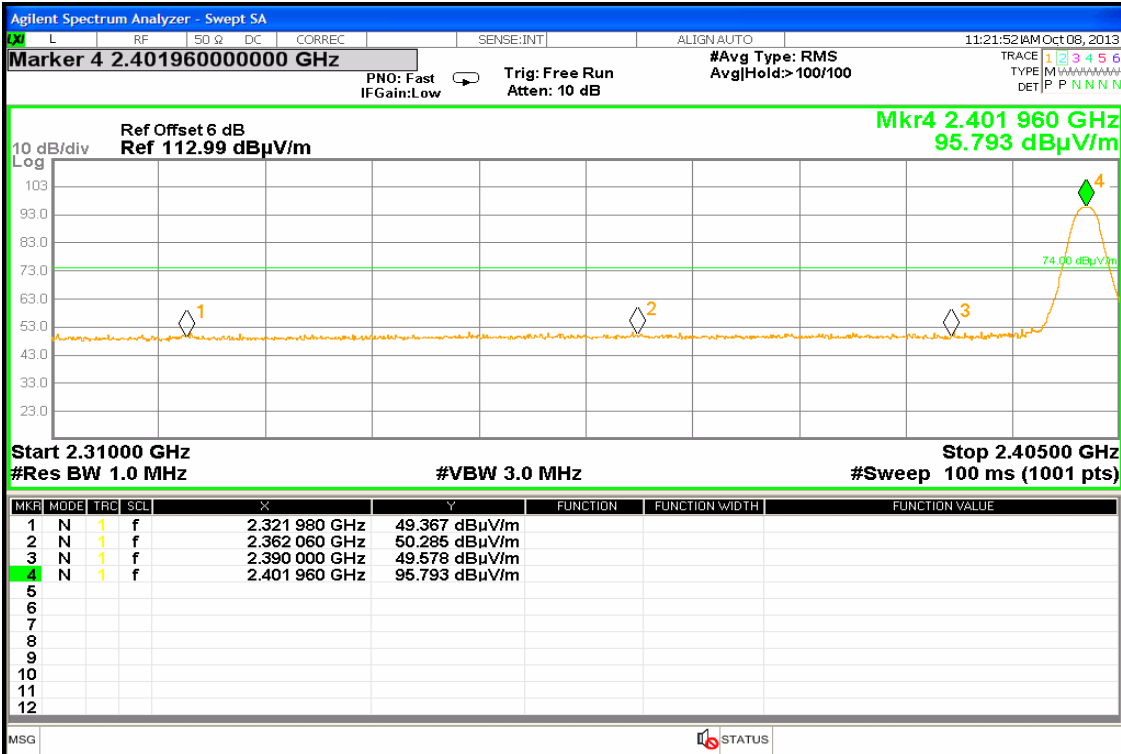

**Detector mode: Average**

**Polarity: Horizontal**

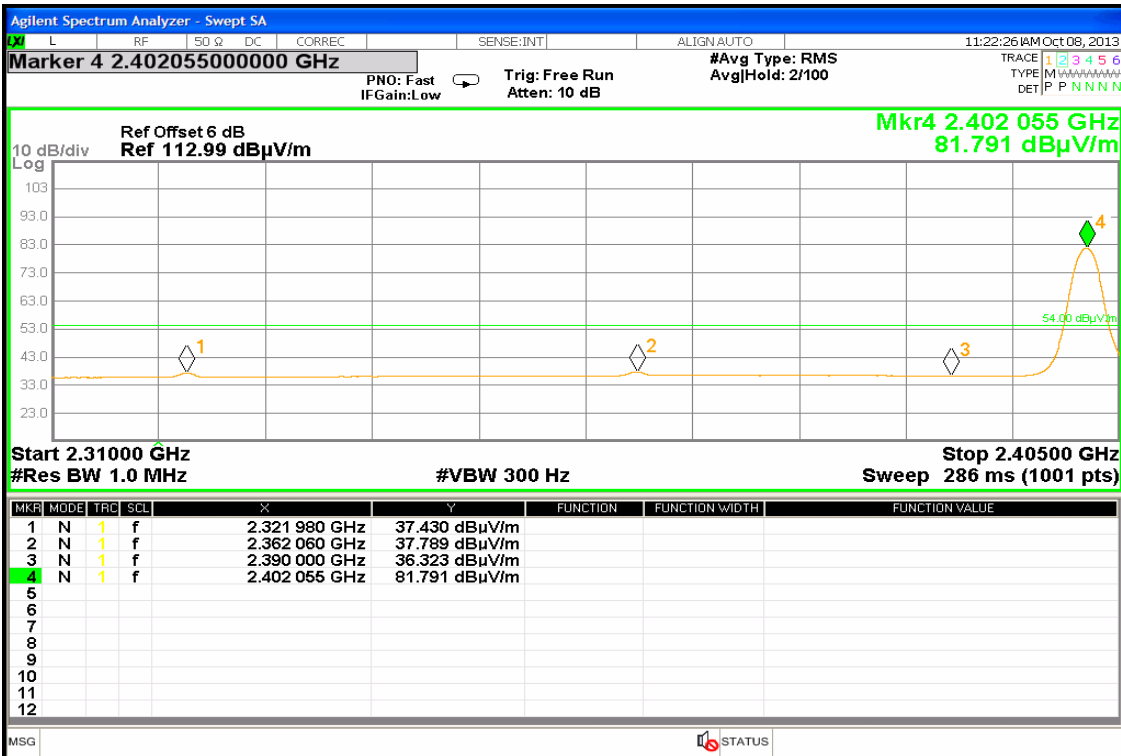



**Compliance Certification Services Inc.**

Report No.: T130822L04-RP2    FCC ID: M82-TREK520    Date of Issue: October 30, 2013

**CH High**

**Detector mode: Peak**

**Polarity: Vertical**

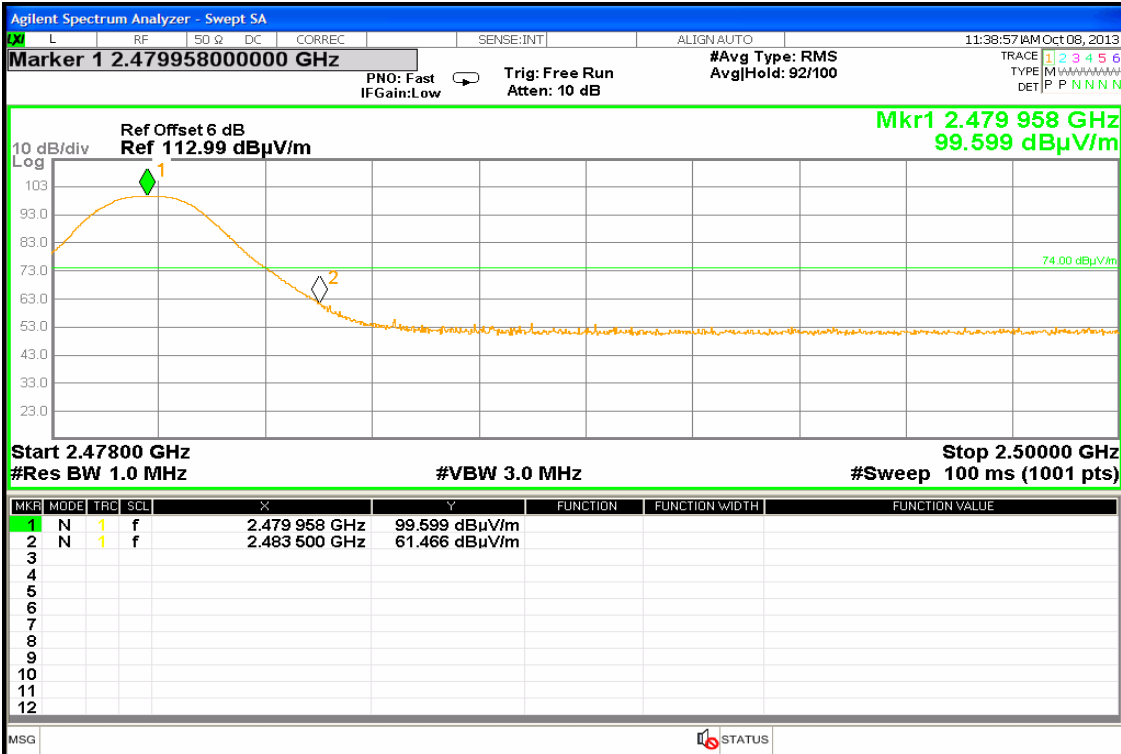

**Detector mode: Average**

**Polarity: Vertical**

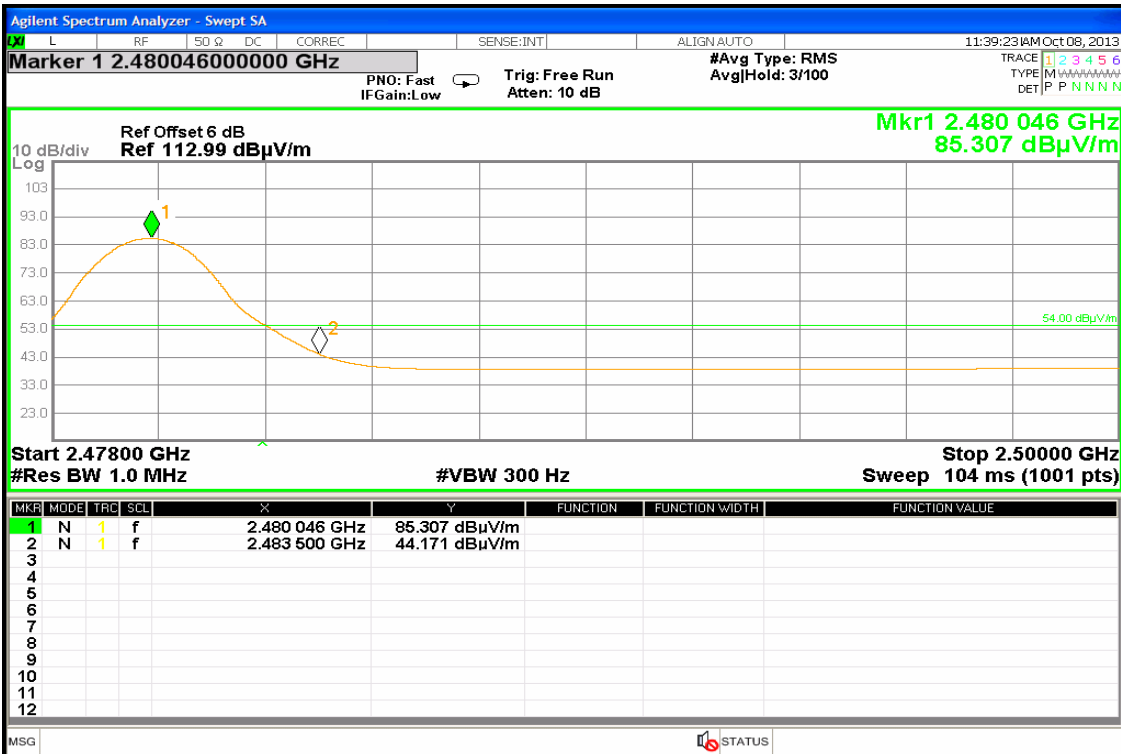



**Detector mode: Peak**

**Polarity: Horizontal**

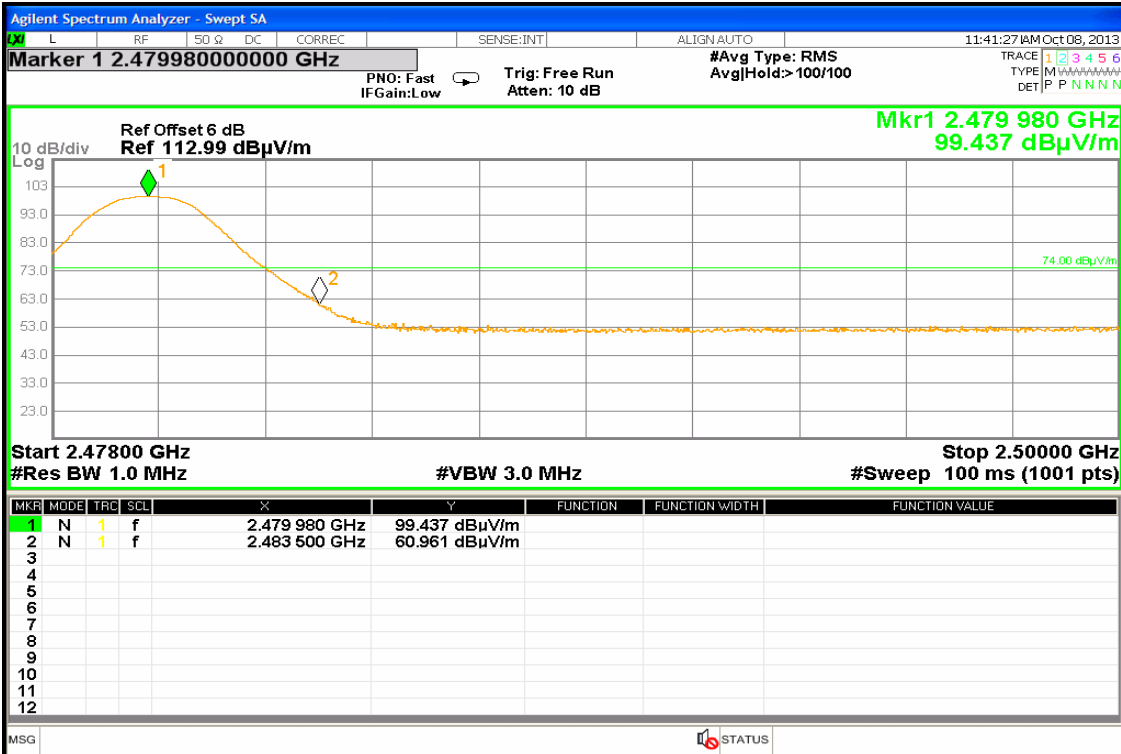

**Detector mode: Average**

**Polarity: Horizontal**

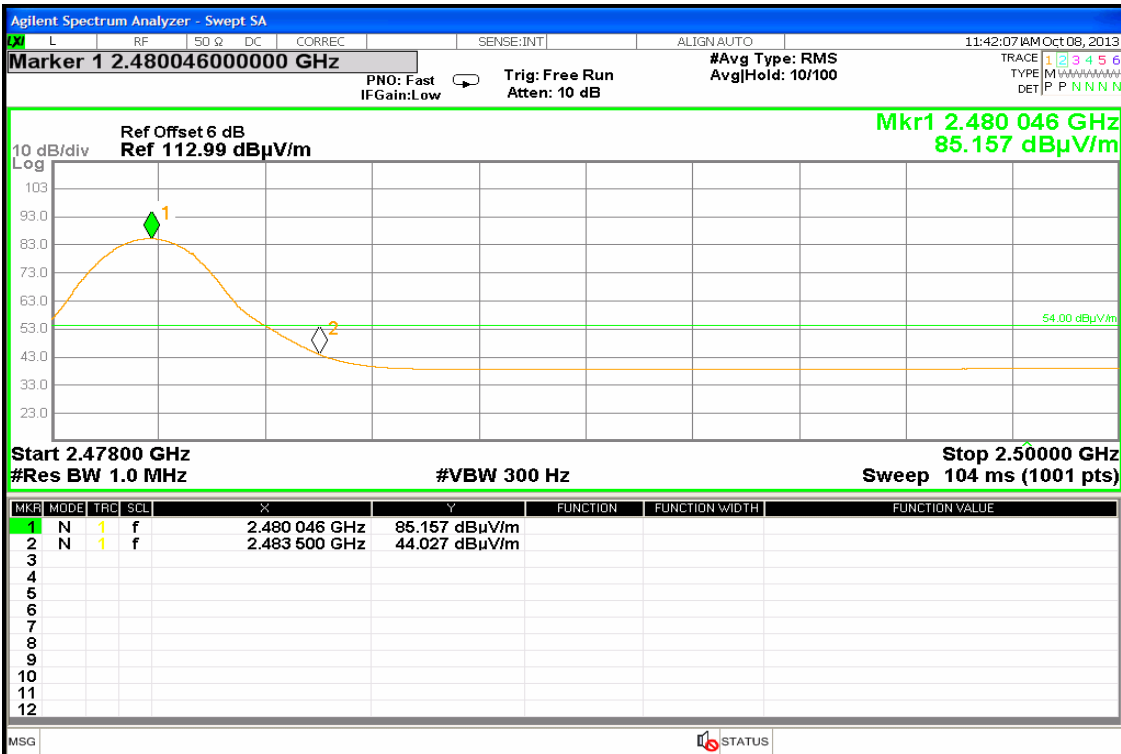



**Conducted band-edge**

**GFSK**

**CH Low**

\* Agilent

R T

Mkr3 2.402 150 GHz  
8.59 dBm

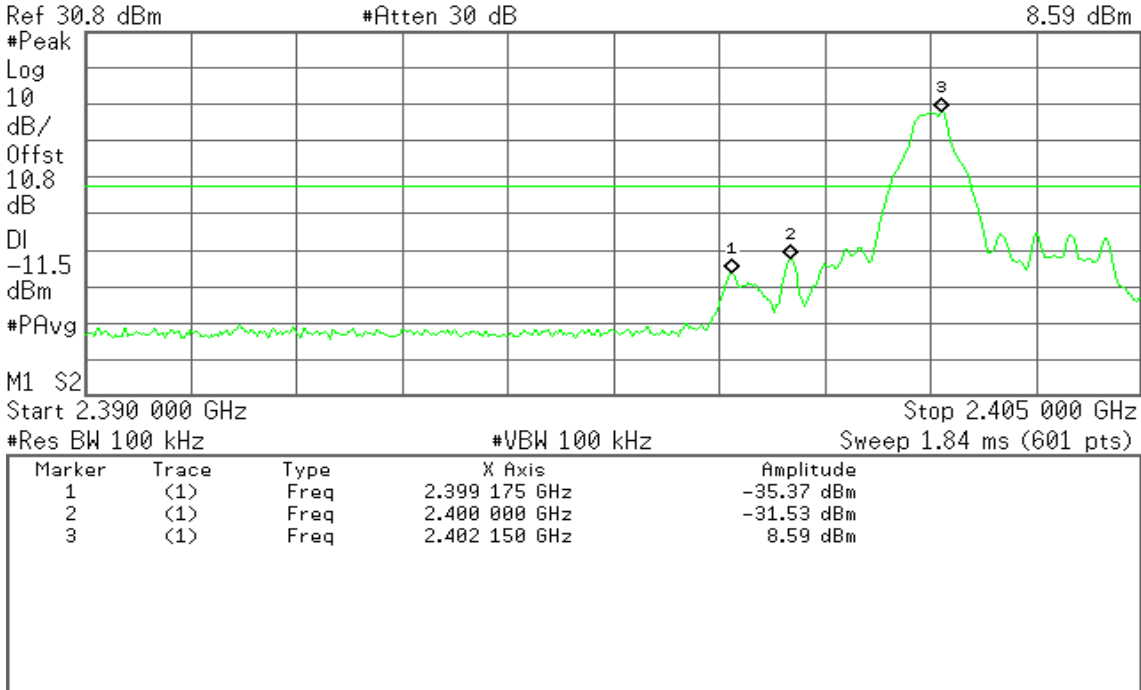

**CH High**

\* Agilent

R T

Mkr1 2.479 98 GHz  
8.61 dBm

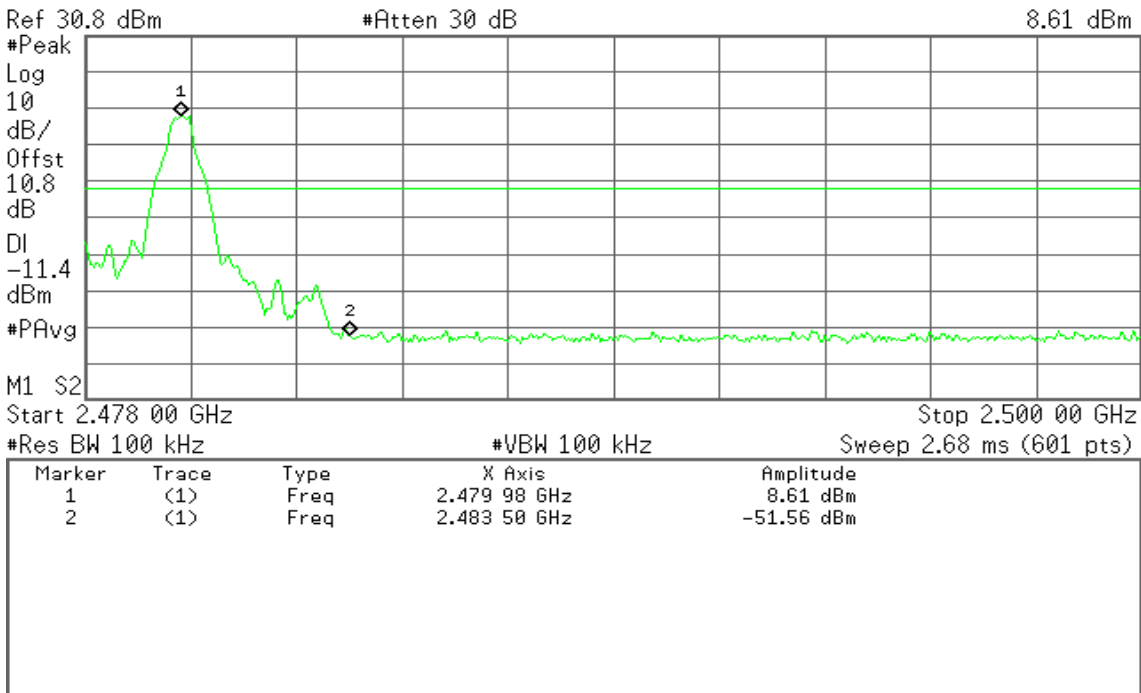



### Hopping On

Agilent

R T

Mkr2 2.465 17 GHz  
9.36 dBm

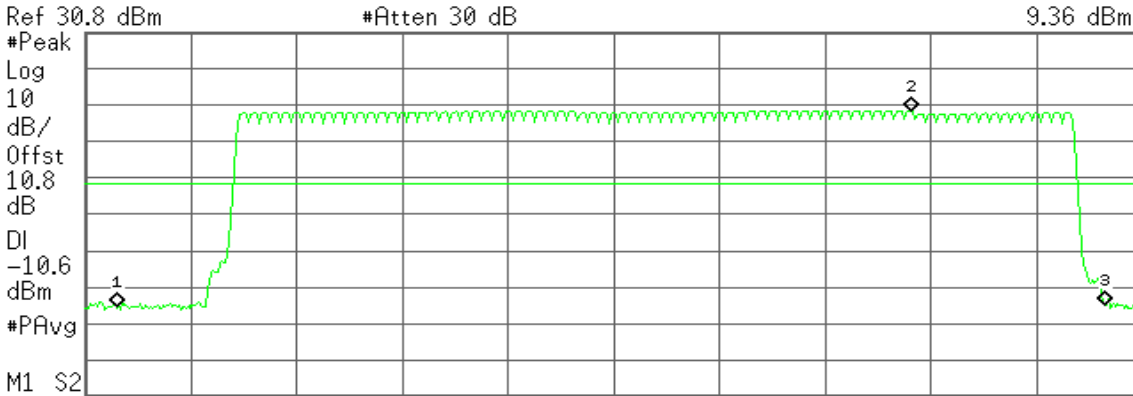

Start 2.387 00 GHz    Stop 2.487 00 GHz  
#Res BW 510 kHz    #VBW 510 kHz    Sweep 1 ms (601 pts)

Marker	Trace	Type	X Axis	Amplitude
1	(1)	Freq	2.390 00 GHz	-44.74 dBm
2	(1)	Freq	2.465 17 GHz	9.36 dBm
3	(1)	Freq	2.483 50 GHz	-44.00 dBm

### Hopping Off

Agilent

R T

Mkr2 2.480 00 GHz  
8.68 dBm

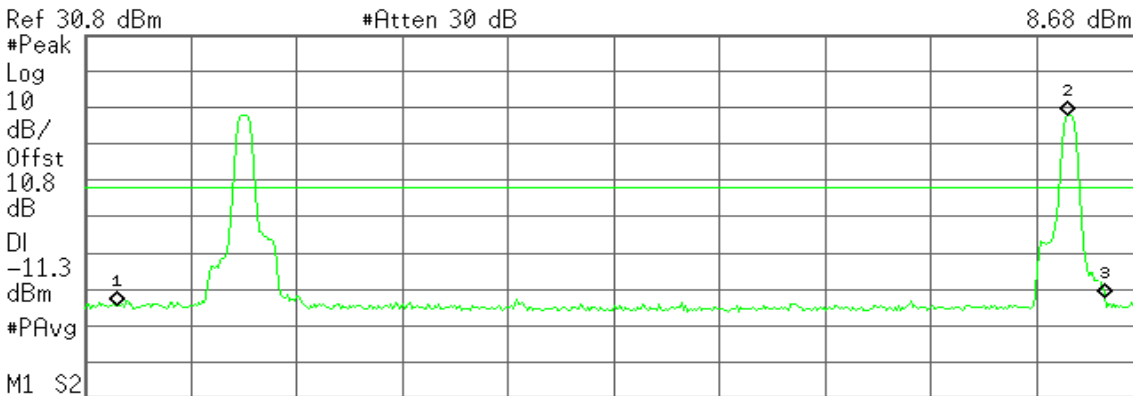

Start 2.387 00 GHz    Stop 2.487 00 GHz  
#Res BW 510 kHz    #VBW 510 kHz    Sweep 1 ms (601 pts)

Marker	Trace	Type	X Axis	Amplitude
1	(1)	Freq	2.390 00 GHz	-43.52 dBm
2	(1)	Freq	2.480 00 GHz	8.68 dBm
3	(1)	Freq	2.483 50 GHz	-41.63 dBm





### 8DPSK

### CH Low

Agilent

R T

Mkr2 2.402 150 GHz  
7.63 dBm

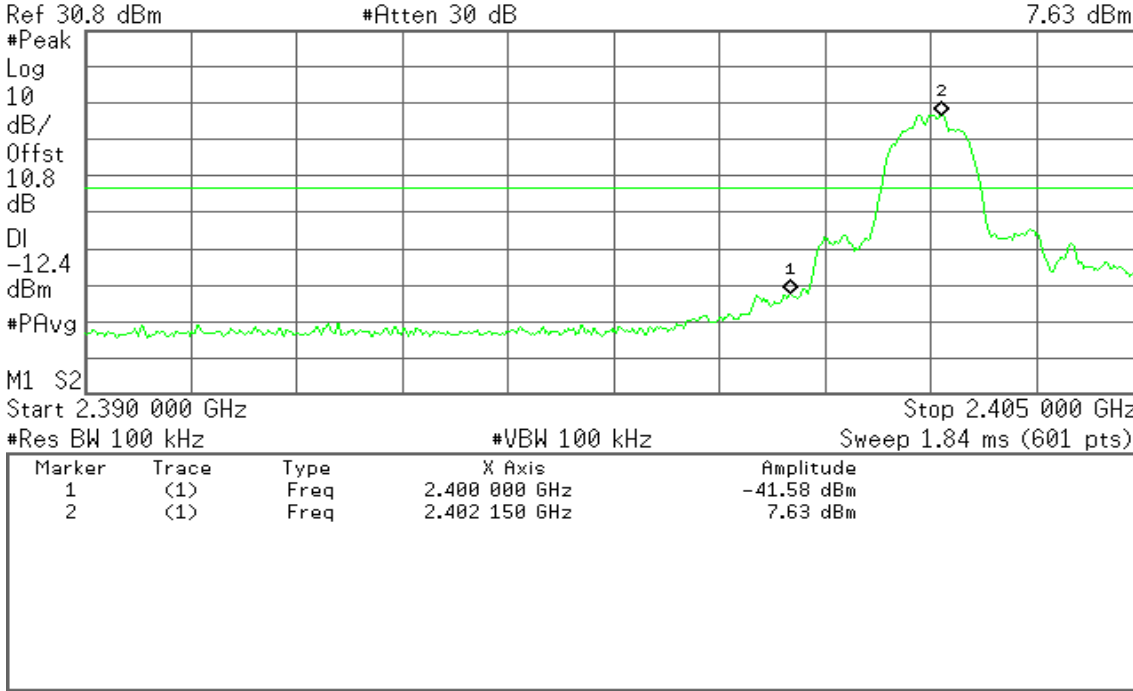

### CH High

Agilent

R T

Mkr1 2.479 98 GHz  
7.57 dBm

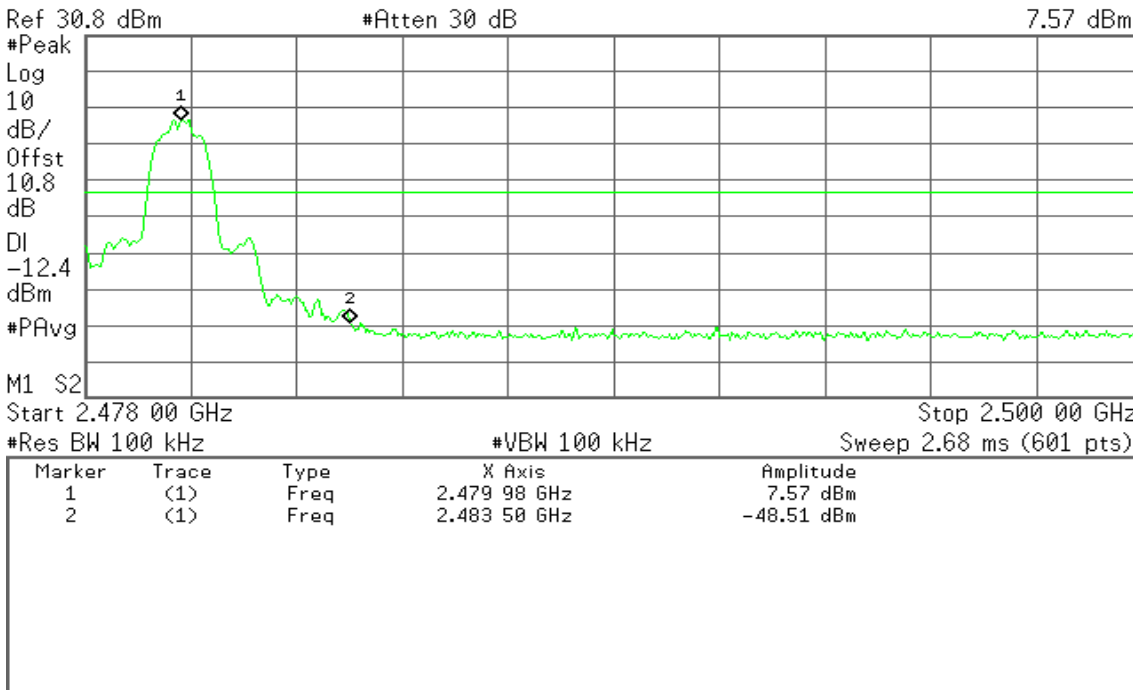



### Hopping On

Agilent

R T

Mkr2 2.463 17 GHz  
8.57 dBm

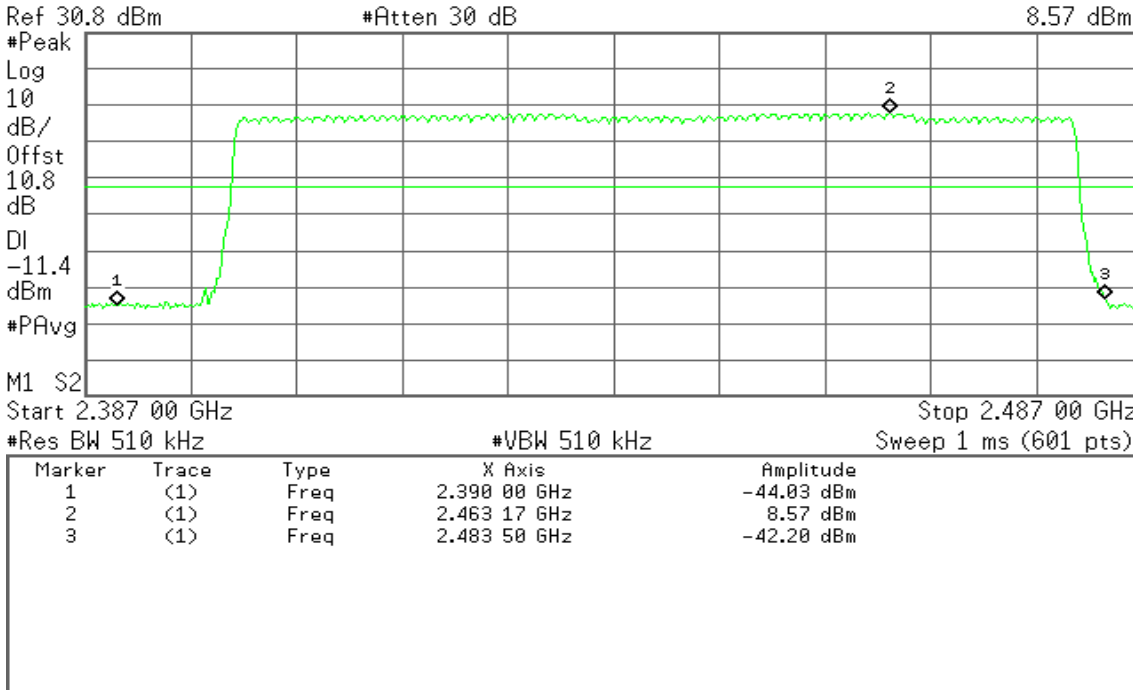

### Hopping Off

Agilent

R T

Mkr2 2.402 17 GHz  
7.61 dBm

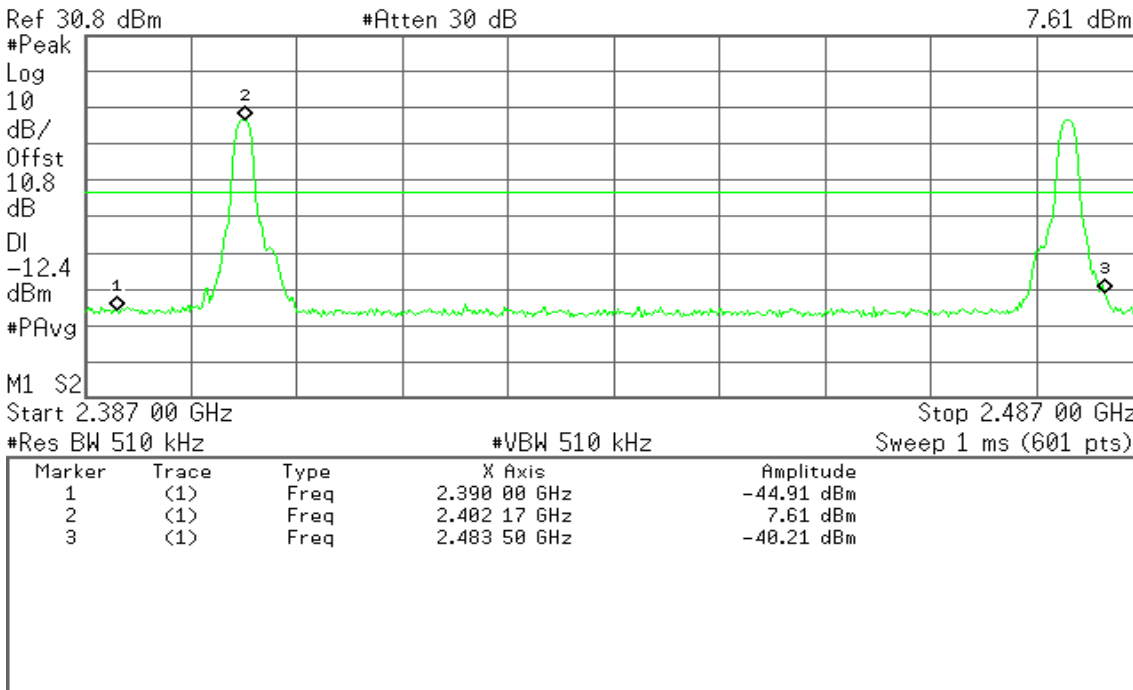



## **7.5. FREQUENCY SEPARATION**

### **LIMIT**

According to §15.247(a)(1), Frequency hopping systems shall have hopping channel carrier frequencies separated by a minimum of 25 kHz or the 20 dB bandwidth of the hopping channel, whichever is greater. Alternatively, frequency hopping systems operating in the 2400-2483.5 MHz band may have hopping channel carrier frequencies that are separated by 25 kHz or two-thirds of the 20 dB bandwidth of the hopping channel, whichever is greater, provided the systems operate with an output power no greater than 125 mW.

### **TEST CONFIGURATION**

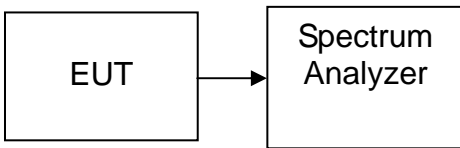

### **TEST PROCEDURE**

1. Place the EUT on the table and set it in transmitting mode.
2. Remove the antenna from the EUT and then connect a low loss RF cable from the antenna port to the spectrum analyzer.
3. Set center frequency of spectrum analyzer = middle of hopping channel.
4. Set the spectrum analyzer as RBW = 30kHz, VBW = 100kHz, Span = 3MHz, Sweep = auto.
5. Max hold, mark 3 peaks of hopping channel and record the 3 peaks frequency.

### **TEST RESULTS**

*No non-compliance noted*

### **TEST DATA**

#### **GFSK**

<b>Channel Separation (MHz)</b>	<b>two-thirds of the 20 dB bandwidth</b>	<b>Channel Separation Limit</b>	<b>Result</b>
1.00	620	> 20dB Bandwidth or two-thirds of the 20 dB bandwidth	Pass

#### **8DPSK**

<b>Channel Separation (MHz)</b>	<b>two-thirds of the 20 dB bandwidth</b>	<b>Channel Separation Limit</b>	<b>Result</b>
1.00	860	> 20dB Bandwidth or two-thirds of the 20 dB bandwidth	Pass



**Test Plot**

**Measurement of Channel Separation**

**GFSK**

Agilent

R T

Mkr2 2.440 995 GHz  
7.82 dBm

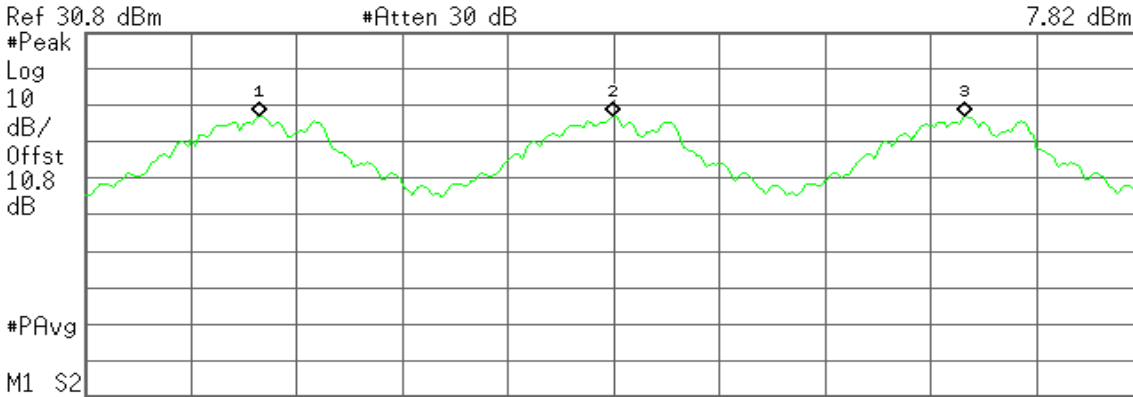

Center 2.441 000 GHz                      Span 3 MHz  
#Res BW 30 kHz                      #VBW 100 kHz                      Sweep 3.2 ms (601 pts)

Marker	Trace	Type	X Axis	Amplitude
1	(1)	Freq	2.439 995 GHz	7.84 dBm
2	(1)	Freq	2.440 995 GHz	7.82 dBm
3	(1)	Freq	2.441 995 GHz	7.80 dBm

**8DPSK**

Agilent

R T

Mkr3 2.442 000 GHz  
7.11 dBm

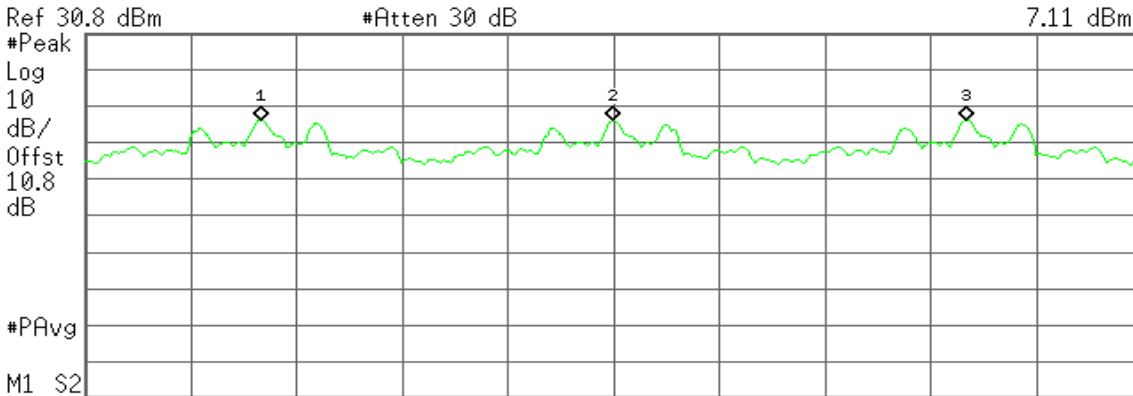

Center 2.441 000 GHz                      Span 3 MHz  
#Res BW 30 kHz                      #VBW 100 kHz                      Sweep 3.2 ms (601 pts)

Marker	Trace	Type	X Axis	Amplitude
1	(1)	Freq	2.440 000 GHz	7.12 dBm
2	(1)	Freq	2.441 000 GHz	7.14 dBm
3	(1)	Freq	2.442 000 GHz	7.11 dBm



## **7.6. NUMBER OF HOPPING FREQUENCY**

### **LIMIT**

According to §15.247(a)(1)(ii), Frequency hopping systems operating in the 2400MHz-2483.5 MHz bands shall use at least 15 hopping frequencies.

### **TEST CONFIGURATION**

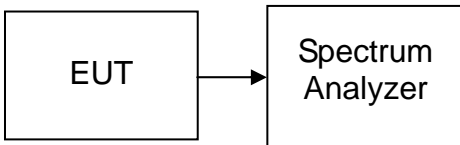

### **TEST PROCEDURE**

1. Place the EUT on the table and set it in transmitting mode.
2. Remove the antenna from the EUT and then connect a low loss RF cable from the antenna port to the spectrum analyzer.
3. Set spectrum analyzer Start=2400MHz, Stop = 2441.5MHz, Sweep = auto and Start=2441.5MHz, Stop = 2483.5MHz, Sweep = auto.
4. Set the spectrum analyzer as RBW, VBW=510kHz.
5. Max hold, view and count how many channel in the band.

### **TEST RESULTS**

*No non-compliance noted*

### **TEST DATA**

<b>Result (No. of CH)</b>	<b>Limit (No. of CH)</b>	<b>Result</b>
79	>15	PASS



**Test Plot**

**GFSK**

**Channel Number**

**2.4 GHz – 2.4415 GHz**

\* Agilent

R T

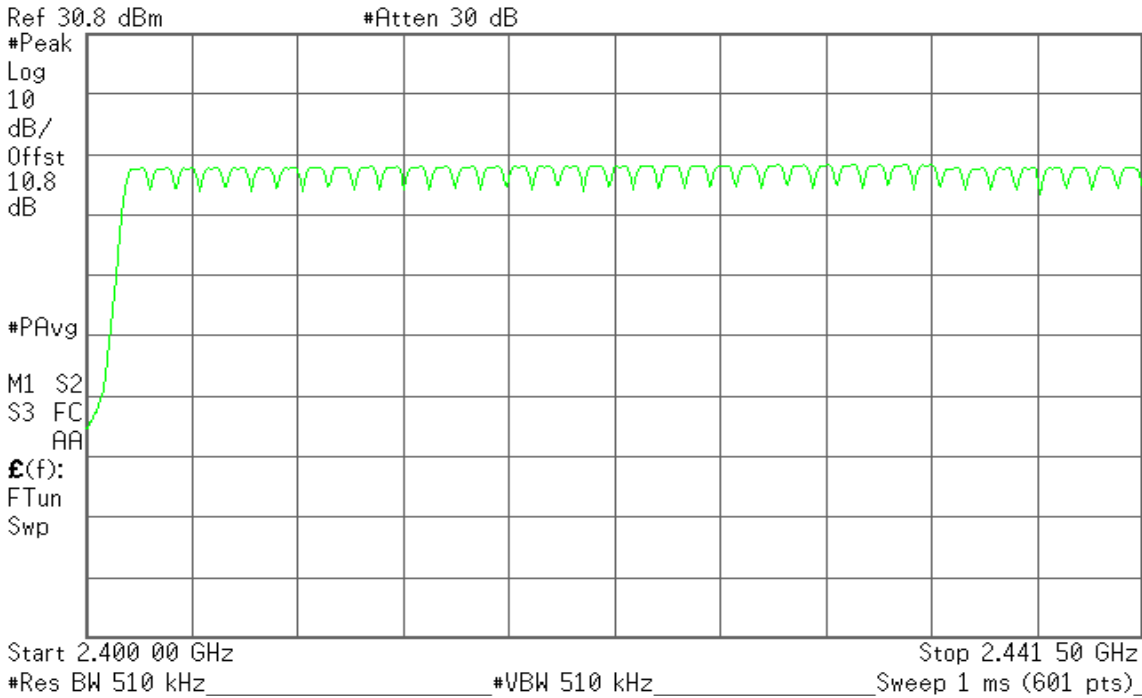

**2.4415 GHz – 2.4835 GHz**

\* Agilent

R T

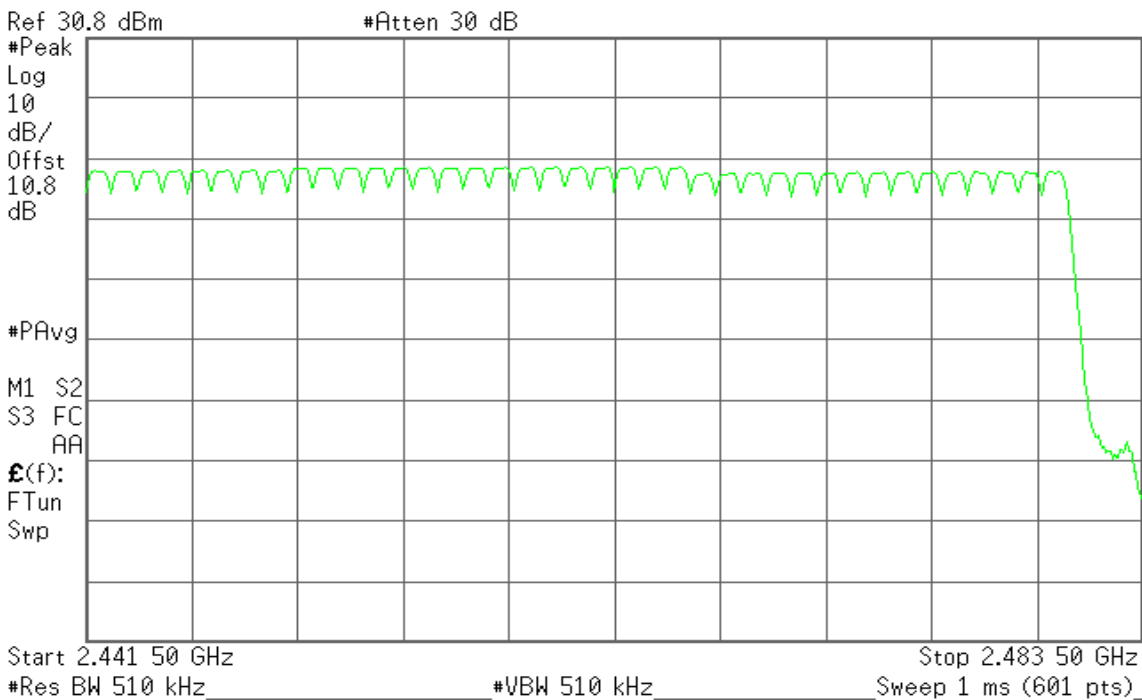



# Compliance Certification Services Inc.

Report No.: T130822L04-RP2    FCC ID: M82-TREK520    Date of Issue: October 30, 2013

## 8DPSK

### Channel Number

2.4 GHz – 2.4415 GHz

Agilent

R T

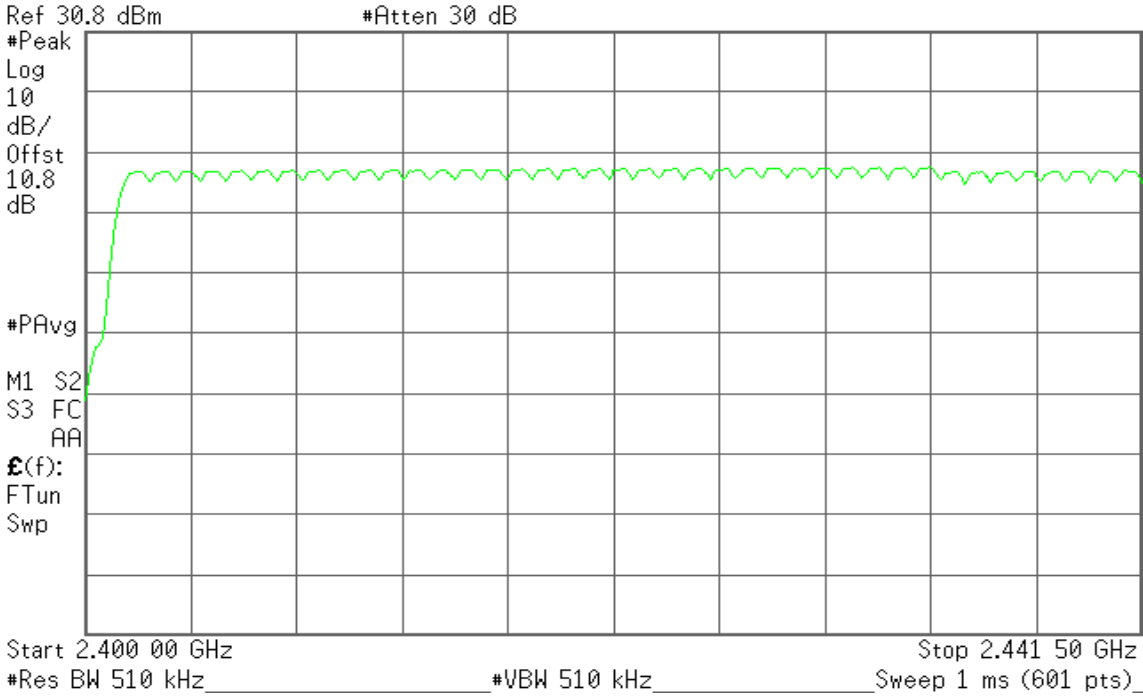

2.4415 GHz – 2.4835 GHz

Agilent

R T

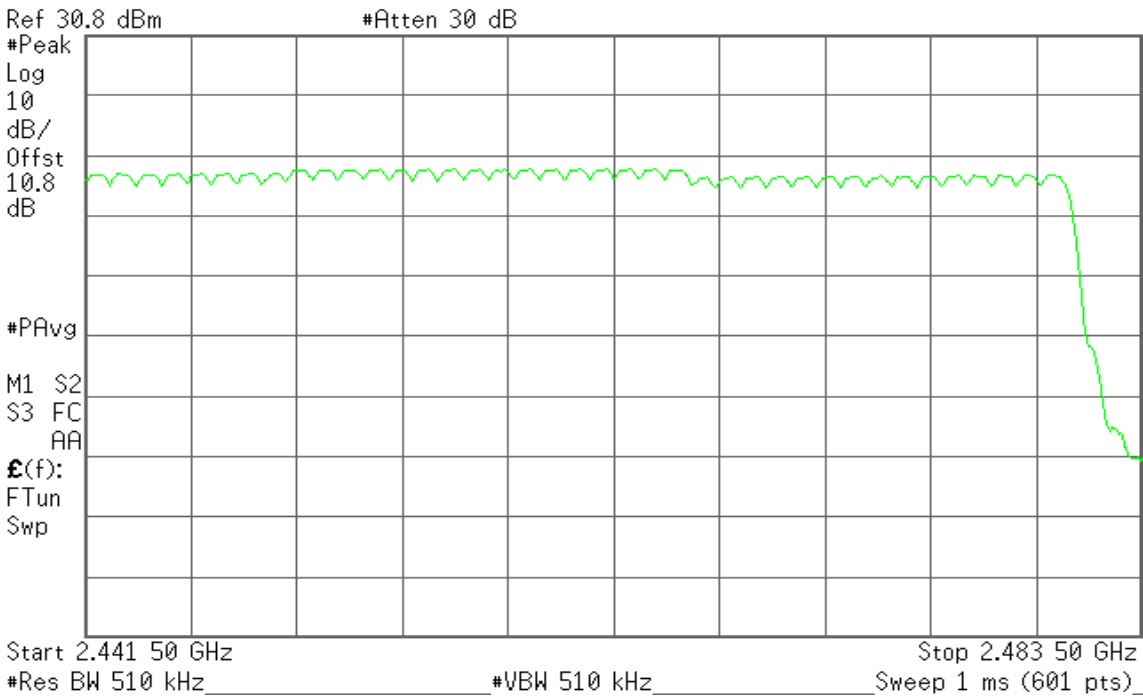



## **7.7. TIME OF OCCUPANCY (DWELL TIME)**

### **LIMIT**

According to §15.247(a)(1)(iii), Frequency hopping systems operating in the 2400MHz-2483.5 MHz bands. The average time of occupancy on any channels shall not greater than 0.4 s within a period 0.4 s multiplied by the number of hopping channels employed.

### **TEST CONFIGURATION**

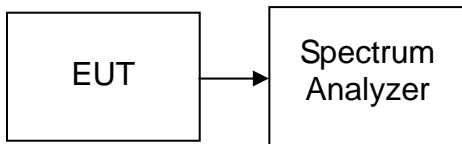

### **TEST PROCEDURE**

1. Place the EUT on the table and set it in transmitting mode.
2. Remove the antenna from the EUT and then connect a low loss RF cable from the antenna port to the spectrum analyzer.
3. Set center frequency of spectrum analyzer = operating frequency.
4. Set the spectrum analyzer as RBW, VBW=1MHz, Span = 0Hz, Sweep = 10ms.
5. Repeat above procedures until all frequency measured were complete.

### **TEST RESULTS**

*No non-compliance noted*





**TEST DATA**

**GFSK**

**DH 1**

CH Low:  $0.3833 * (1600/2)/79 * 31.60 = 122.66$  (ms)

CH Mid:  $0.3833 * (1600/2)/79 * 31.60 = 122.66$  (ms)

CH High:  $0.3833 * (1600/2)/79 * 31.60 = 122.66$  (ms)

CH	Pulse Time (ms)	Total of Dwell (ms)	Period Time (s)	Limit (ms)	Result
Low	0.3833	122.66	31.60	400.00	PASS
Mid	0.3833	122.66	31.60		PASS
High	0.3833	122.66	31.60		PASS

**DH 3**

CH Low:  $1.65 * (1600/4)/79 * 31.60 = 264.00$  (ms)

CH Mid:  $1.65 * (1600/4)/79 * 31.60 = 264.00$  (ms)

CH High:  $1.65 * (1600/4)/79 * 31.60 = 264.00$  (ms)

CH	Pulse Time (ms)	Total of Dwell (ms)	Period Time (s)	Limit (ms)	Result
Low	1.65	264.00	31.60	400.00	PASS
Mid	1.65	264.00	31.60		PASS
High	1.65	264.00	31.60		PASS

**DH 5**

CH Low:  $2.90 * (1600/6)/79 * 31.60 = 309.33$  (ms)

CH Mid:  $2.90 * (1600/6)/79 * 31.60 = 309.33$  (ms)

CH High:  $2.90 * (1600/6)/79 * 31.60 = 309.33$  (ms)

CH	Pulse Time (ms)	Total of Dwell (ms)	Period Time (s)	Limit (ms)	Result
Low	2.90	309.33	31.60	400.00	PASS
Mid	2.90	309.33	31.60		PASS
High	2.90	309.33	31.60		PASS



**8DPSK**

**DH 1**

CH Low:  $0.4167 * (1600/2)/79 * 31.60 = 133.34$  (ms)

CH Mid:  $0.4167 * (1600/2)/79 * 31.60 = 133.34$  (ms)

CH High:  $0.4167 * (1600/2)/79 * 31.60 = 133.34$  (ms)

CH	Pulse Time (ms)	Total of Dwell (ms)	Period Time (s)	Limit (ms)	Result
Low	0.4167	133.34	31.60	400.00	PASS
Mid	0.4167	133.34	31.60		PASS
High	0.4167	133.34	31.60		PASS

**DH 3**

CH Low:  $1.65 * (1600/4)/79 * 31.60 = 264.00$  (ms)

CH Mid:  $1.65 * (1600/4)/79 * 31.60 = 264.00$  (ms)

CH High:  $1.65 * (1600/4)/79 * 31.60 = 264.00$  (ms)

CH	Pulse Time (ms)	Total of Dwell (ms)	Period Time (s)	Limit (ms)	Result
Low	1.65	264.00	31.60	400.00	PASS
Mid	1.65	264.00	31.60		PASS
High	1.65	264.00	31.60		PASS

**DH 5**

CH Low:  $2.90 * (1600/6)/79 * 31.60 = 309.33$  (ms)

CH Mid:  $2.90 * (1600/6)/79 * 31.60 = 309.33$  (ms)

CH High:  $2.90 * (1600/6)/79 * 31.60 = 309.33$  (ms)

CH	Pulse Time (ms)	Total of Dwell (ms)	Period Time (s)	Limit (ms)	Result
Low	2.90	309.33	31.60	400.00	PASS
Mid	2.90	309.33	31.60		PASS
High	2.90	309.33	31.60		PASS



**Test Plot**

**GFSK**

**DH 1**

**(CH Low)**

Agilent

R T

Mkr1 383.3  $\mu$ s  
-4.99 dB

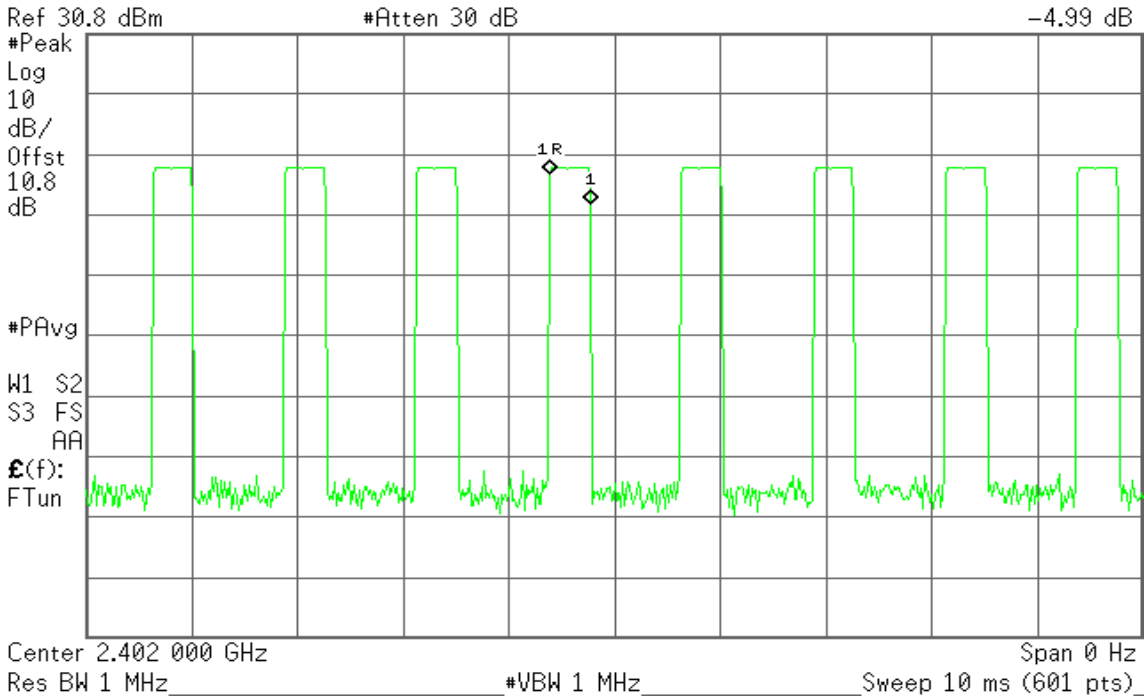

**(CH Mid)**

Agilent

R T

Mkr1 383.3  $\mu$ s  
-6.68 dB

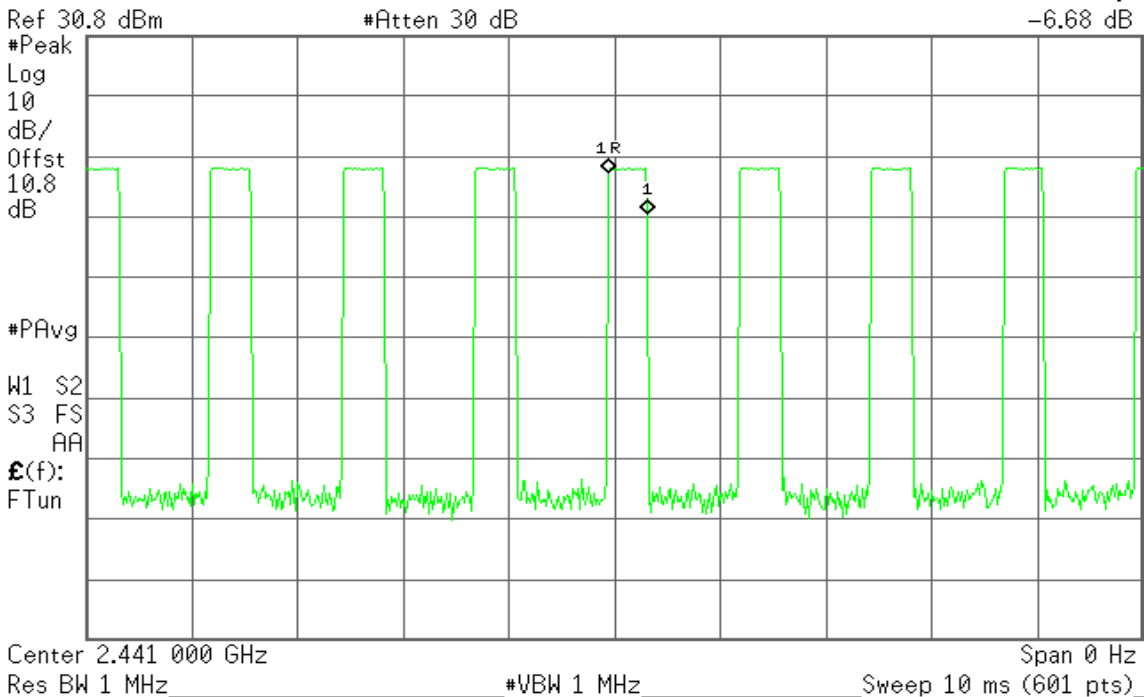



**(CH High)**

Agilent

R T

Mkr1 383.3  $\mu$ s  
-4.21 dB

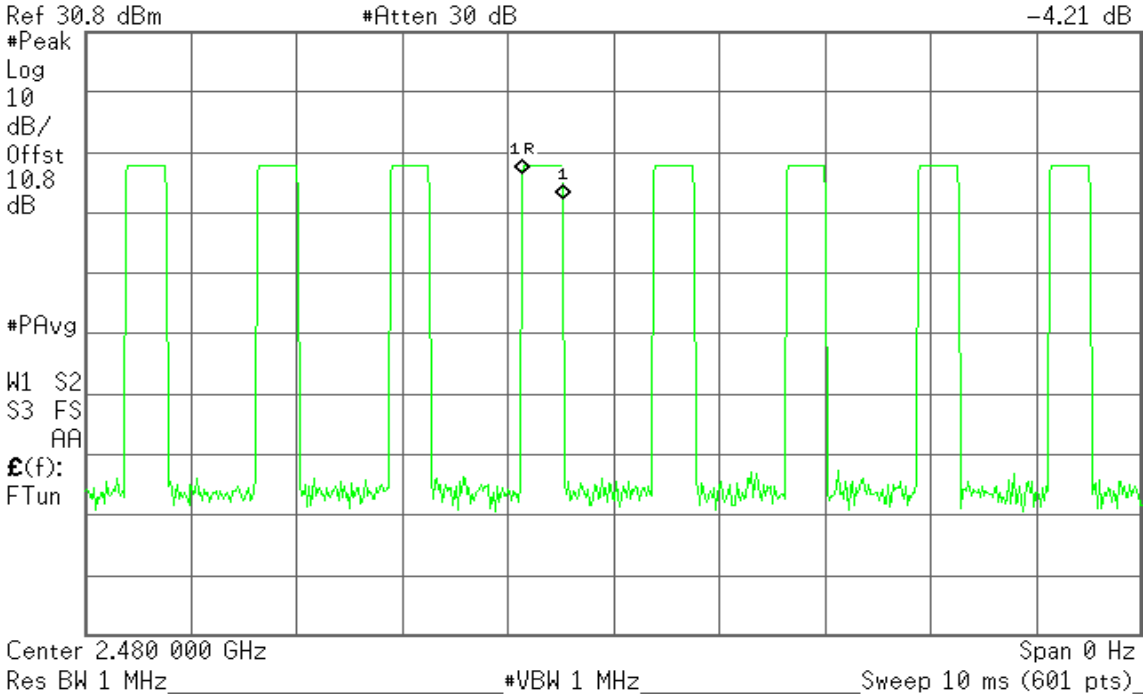

**DH 3**

**(CH Low)**

Agilent

R T

Mkr1 1.65 ms  
0.07 dB

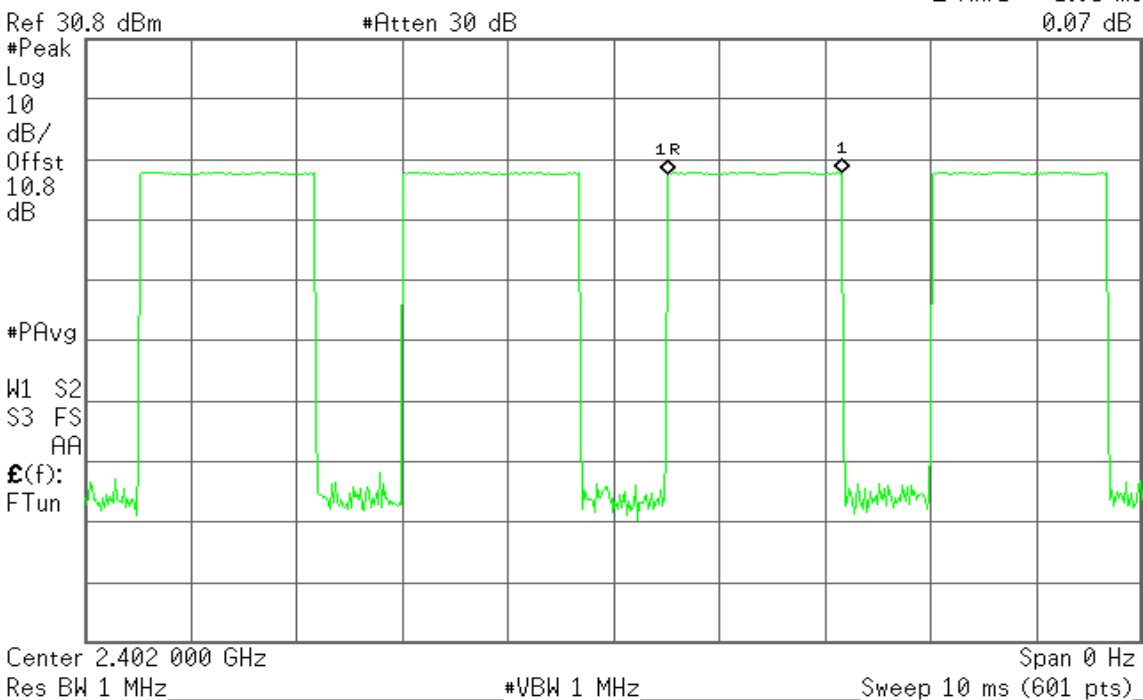



**(CH Mid)**

Agilent

R T

Mkr1 1.65 ms  
0.05 dB

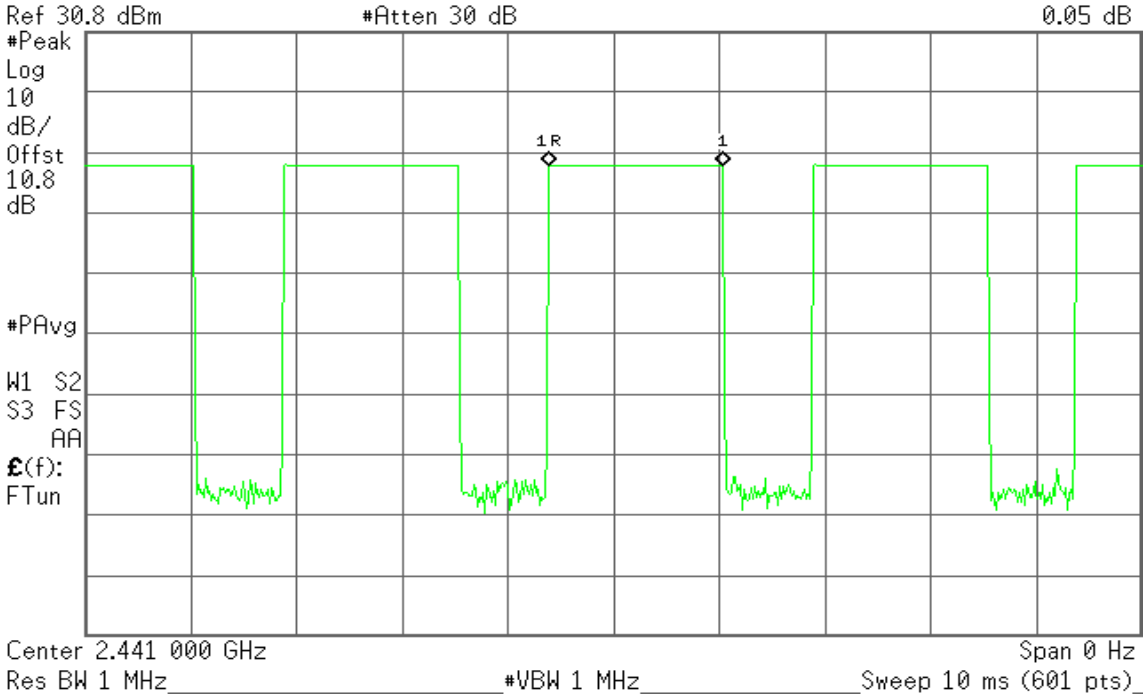

**(CH High)**

Agilent

R T

Mkr1 1.65 ms  
0.05 dB

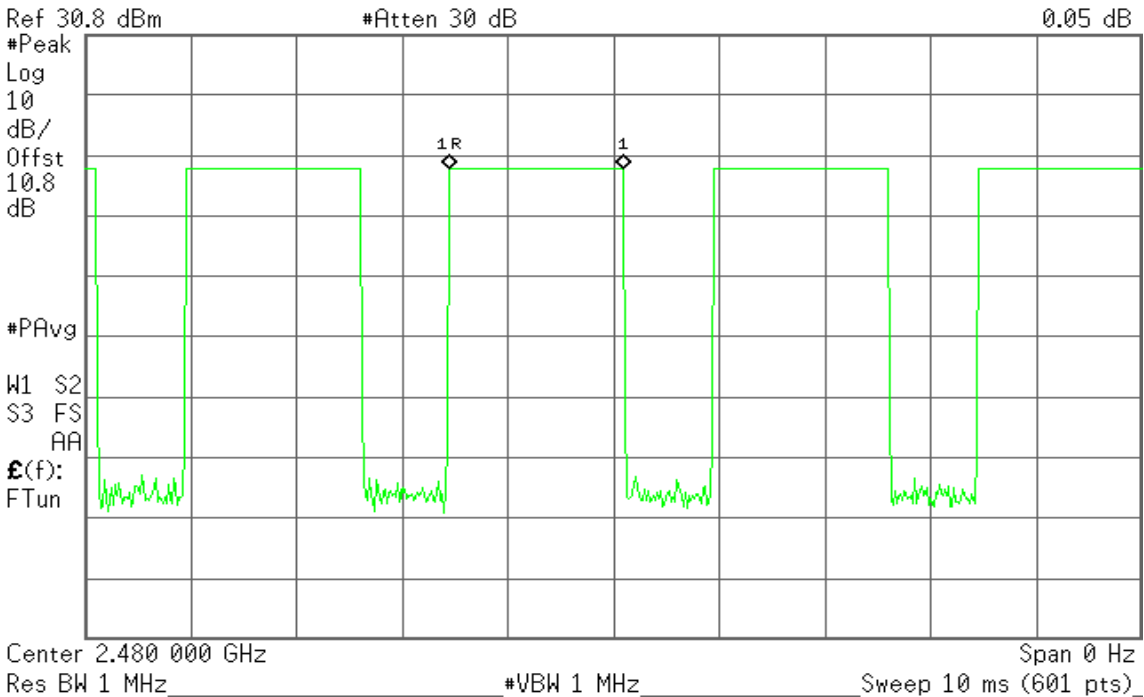



**DH 5**

**(CH Low)**

Agilent

R T

Mkr1 2.9 ms  
0.55 dB

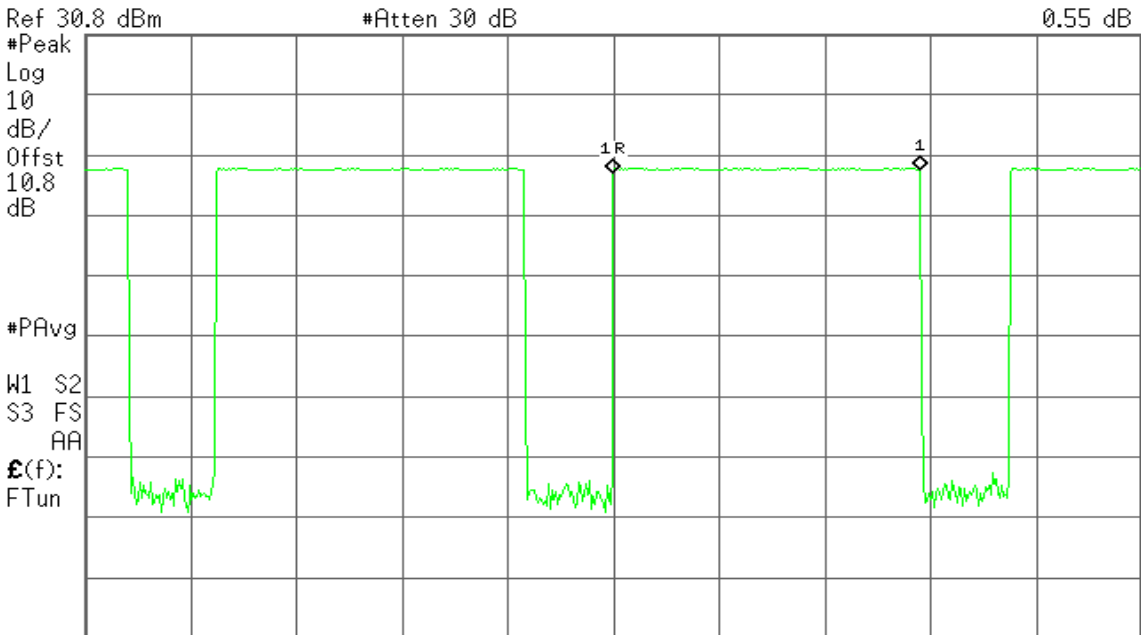

**(CH Mid)**

Agilent

R T

Mkr1 2.9 ms  
2.29 dB





**(CH High)**

Agilent

R T

▲ Mkr1 2.9 ms  
2.93 dB

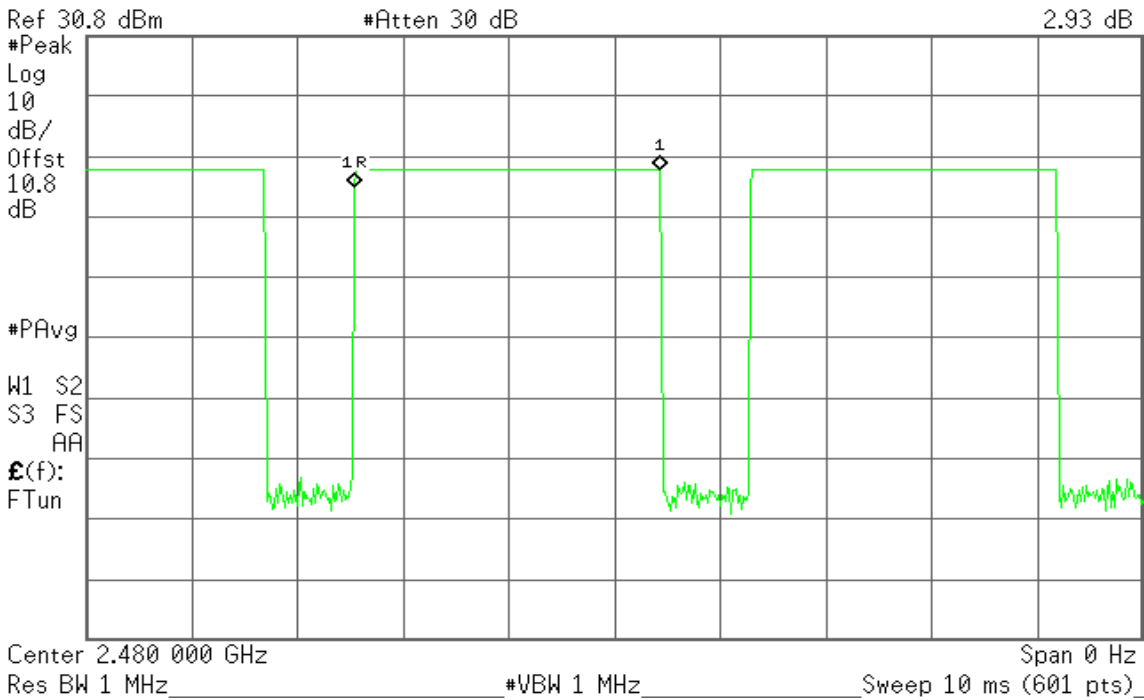

**8DPSK**

**DH 1**

**(CH Low)**

Agilent

R T

▲ Mkr1 416.7  $\mu$ s  
-2.38 dB

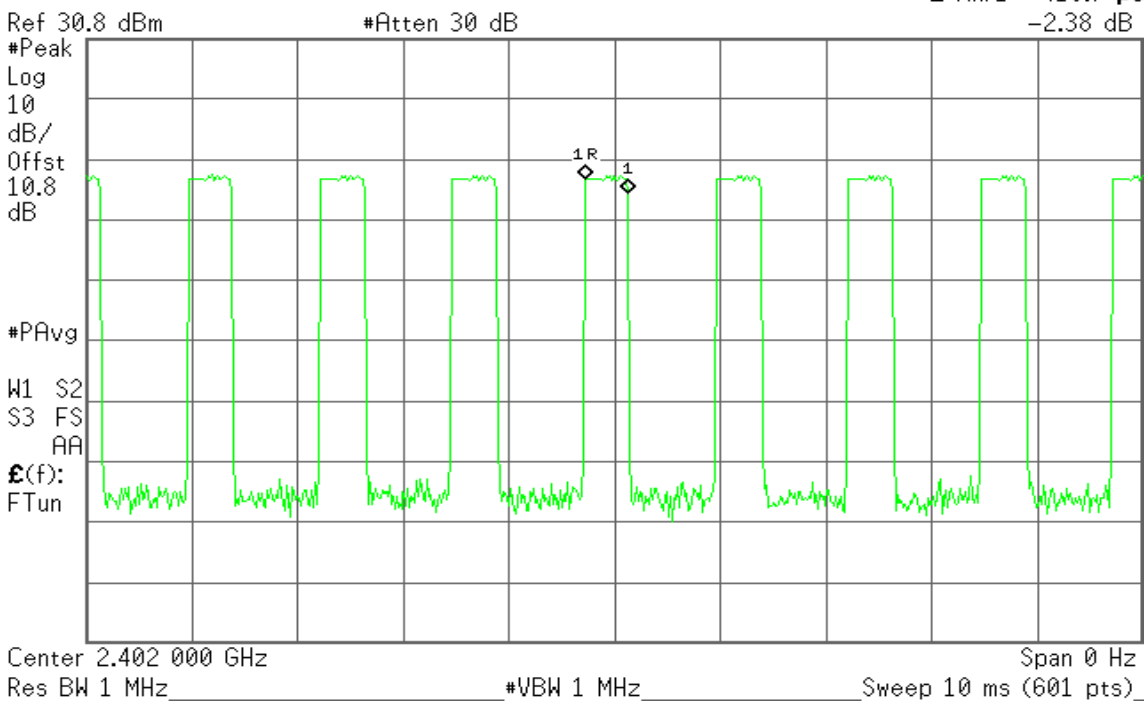



**(CH Mid)**

Agilent

R T

Mkr1 416.7  $\mu$ s  
-6.85 dB

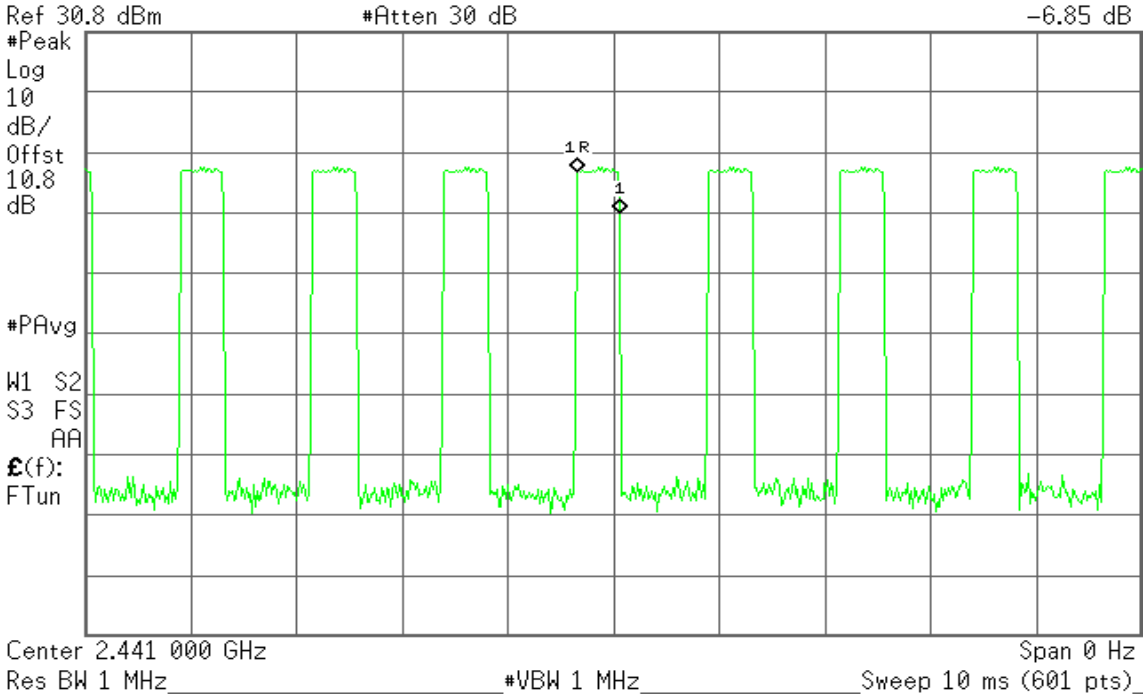

**(CH High)**

Agilent

R T

Mkr1 416.7  $\mu$ s  
-5.46 dB

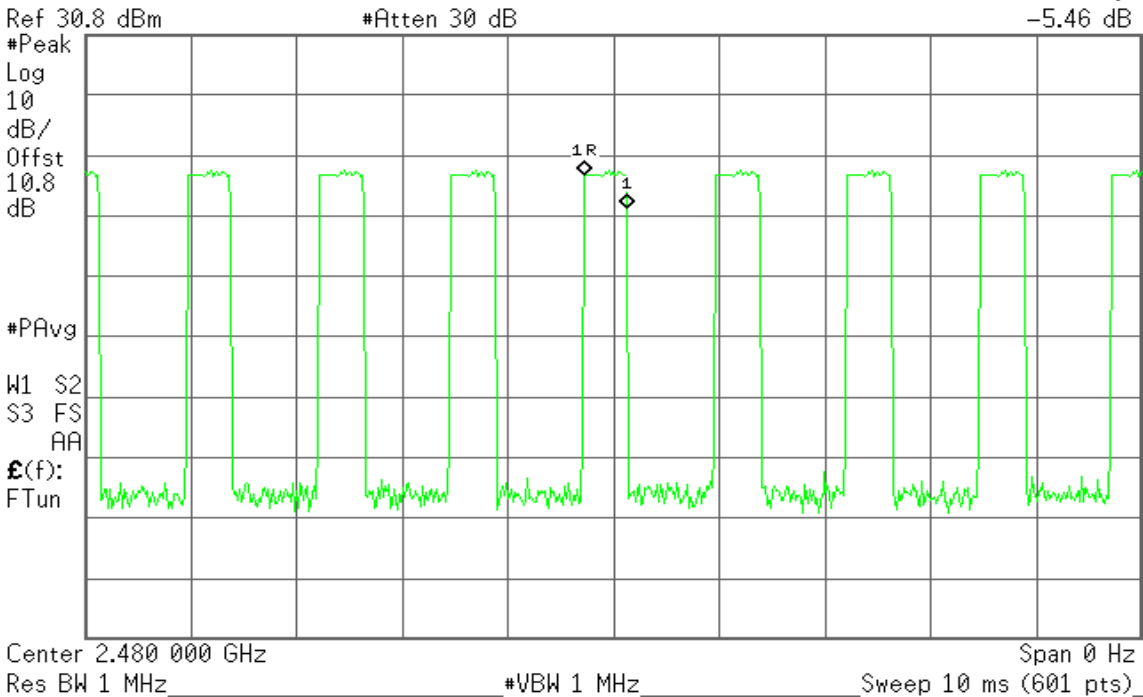





**DH 3**

**(CH Low)**

Agilent

R T

Mkr1 1.65 ms  
-0.28 dB

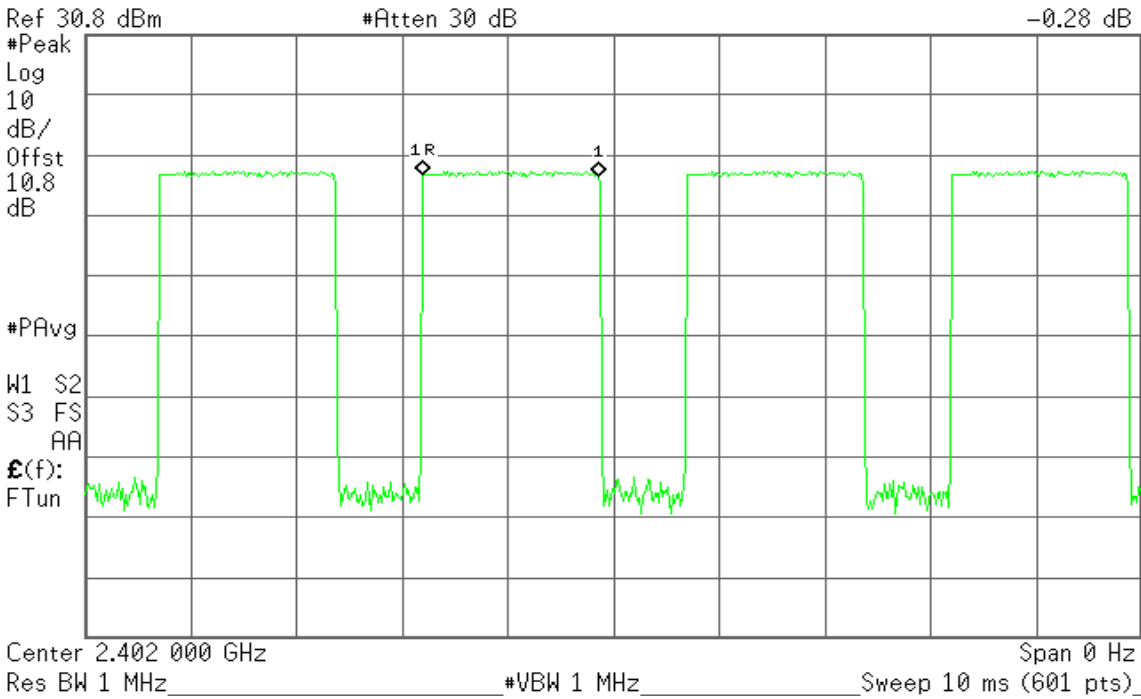

**(CH Mid)**

Agilent

R T

Mkr1 1.65 ms  
-0.68 dB

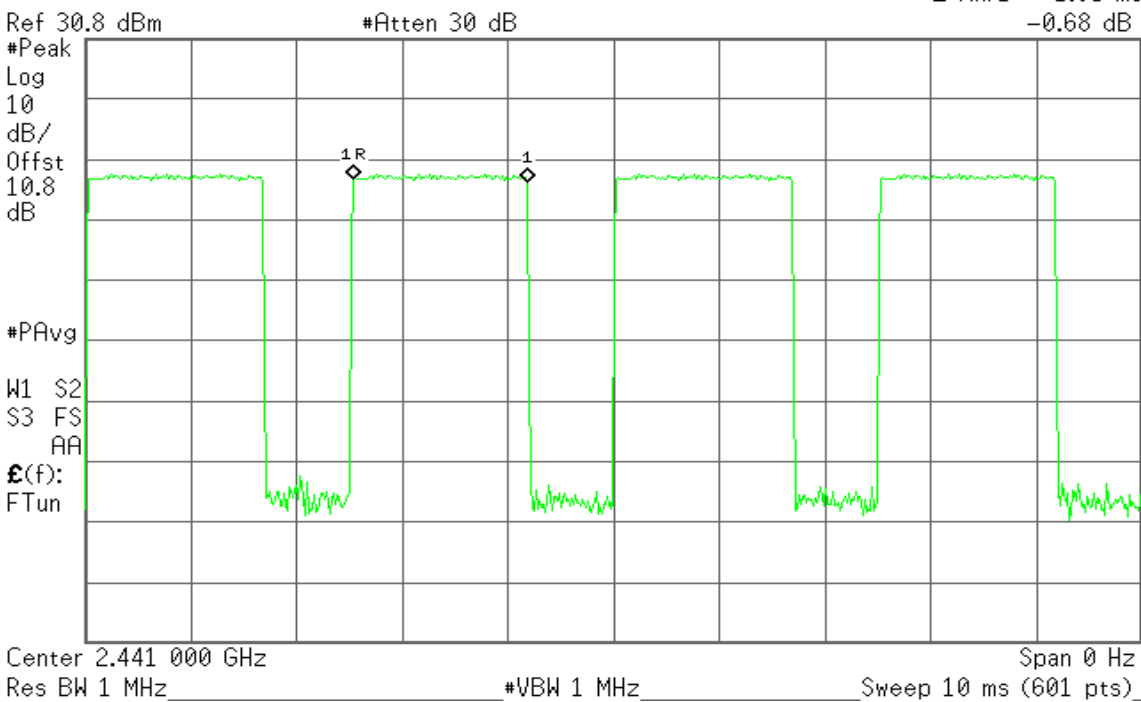



**(CH High)**

Agilent

R T

Mkr1 1.65 ms  
-0.22 dB

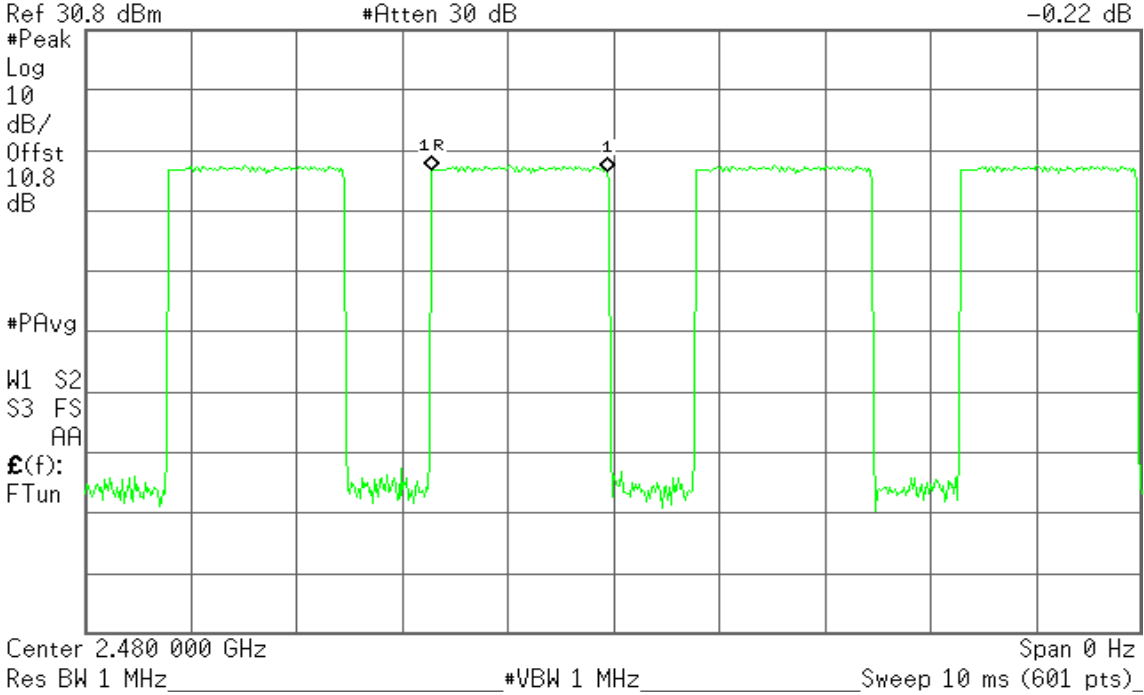

**DH 5**

**(CH Low)**

Agilent

R T

Mkr1 2.9 ms  
-0.67 dB

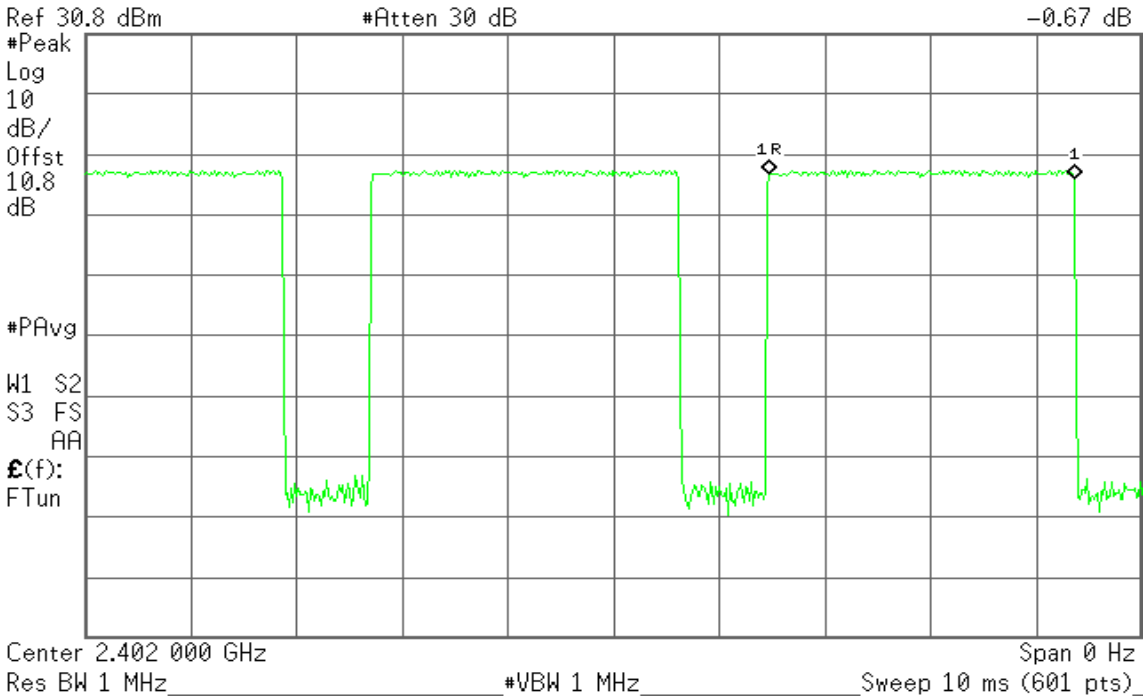



**(CH Mid)**

Agilent

R T

Mkr1 2.9 ms  
0.23 dB

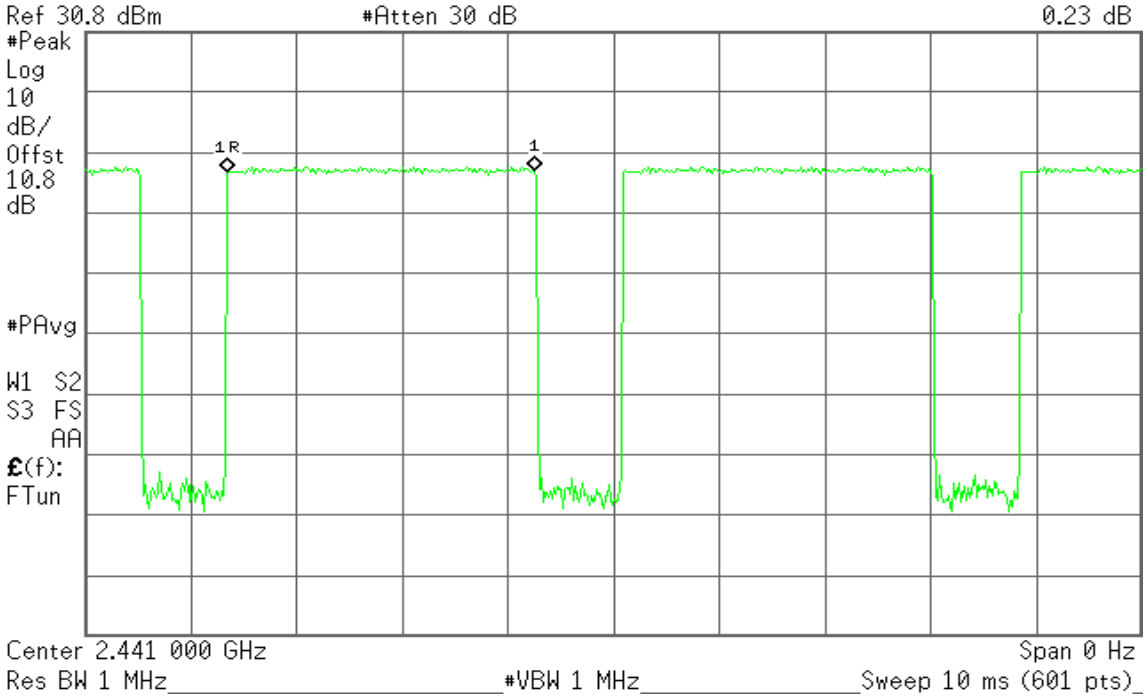

**(CH High)**

Agilent

R T

Mkr1 2.9 ms  
0.57 dB

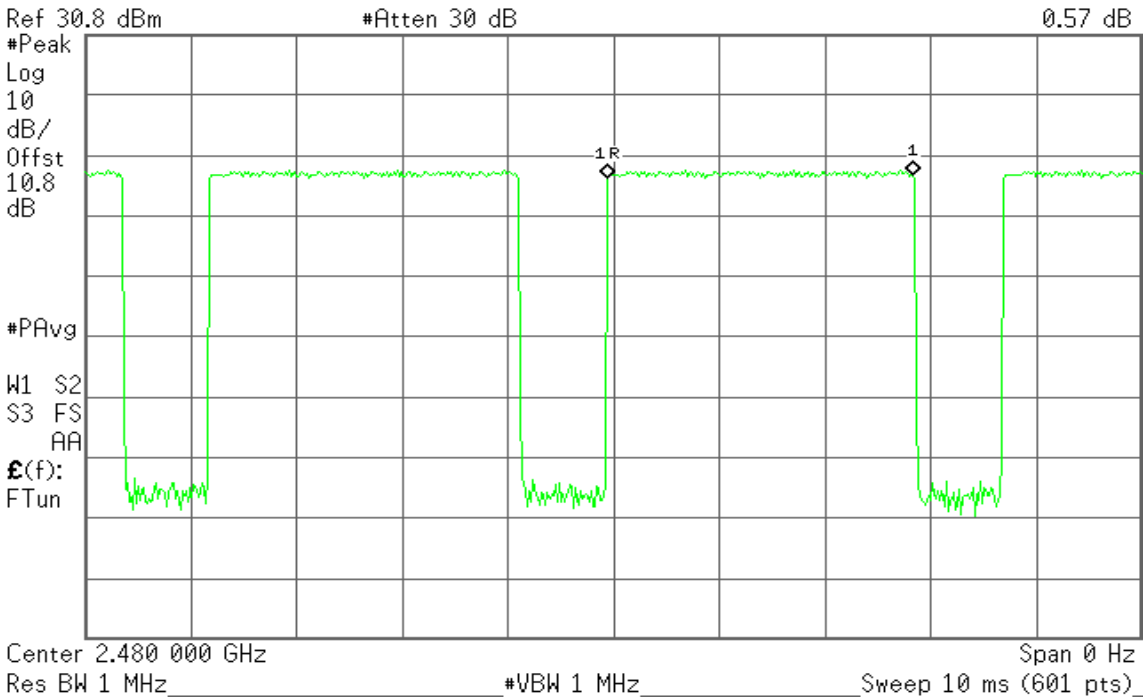



## **7.8. SPURIOUS EMISSIONS**

### **7.8.1 Conducted Measurement**

#### **LIMIT**

In any 100 kHz bandwidth outside the frequency band in which the spread spectrum or digitally modulated intentional radiator is operating, the radio frequency power that is produced by the intentional radiator shall be at least 20 dB below that in the 100 kHz bandwidth within the band that contains the highest level of the desired power, based on either an RF conducted or a radiated measurement. Attenuation below the general limits specified in Section 15.209(a) is not required. In addition, radiated emissions which fall in the restricted bands, as defined in Section 15.205(a), must also comply with the radiated emission limits specified in Section 15.209(a) (see Section 15.205(c)).

#### **TEST CONFIGURATION**

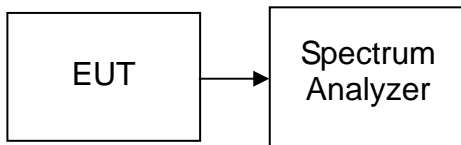

#### **TEST PROCEDURE**

Conducted RF measurements of the transmitter output were made to confirm that the EUT antenna port conducted emissions meet the specified limit and to identify any spurious signals that require further investigation or measurements on the radiated emissions site.

The transmitter output is connected to the spectrum analyzer. The resolution bandwidth is set to 100 kHz. The video bandwidth is set to 100 kHz.

Measurements are made over the 30MHz to 26GHz range with the transmitter set to the lowest, middle, and highest channels.

#### **TEST RESULTS**

*No non-compliance noted*

#### **TEST DATA**

Refer to attach spectrum analyzer data chart.



**Test Plot**

**Spurious Emissions**

**GFSK**

**CH Low**

Agilent

R T

Mkr1 2.41 GHz  
7.40 dBm

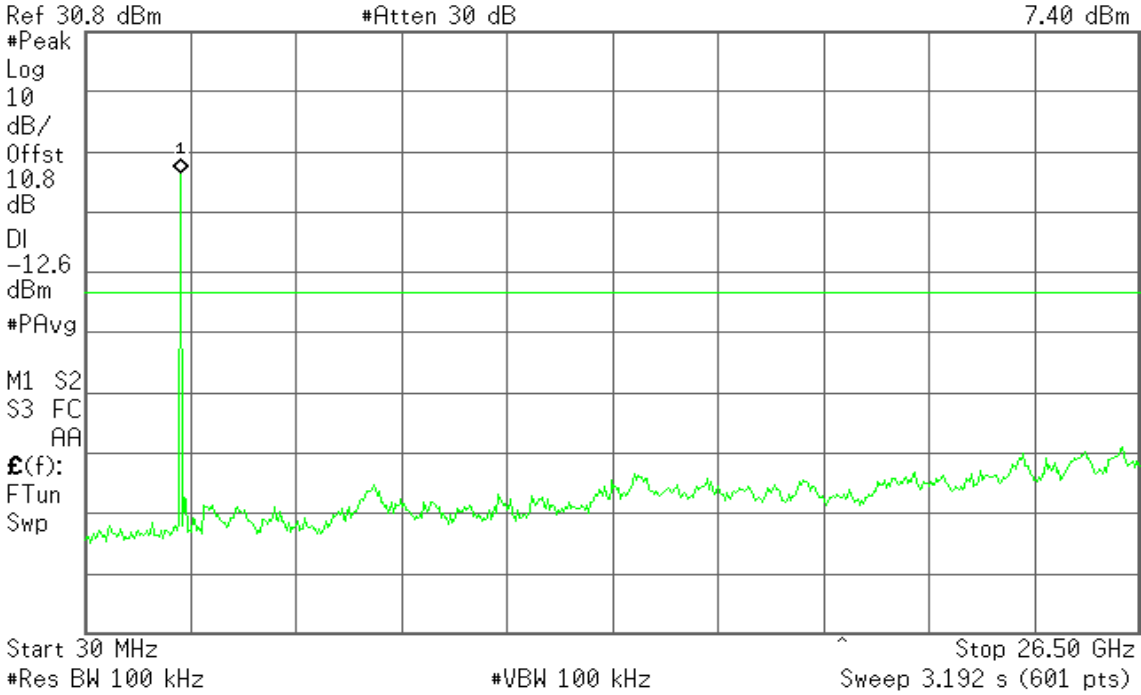

**CH Mid**

Agilent

R T

Mkr1 2.46 GHz  
9.08 dBm

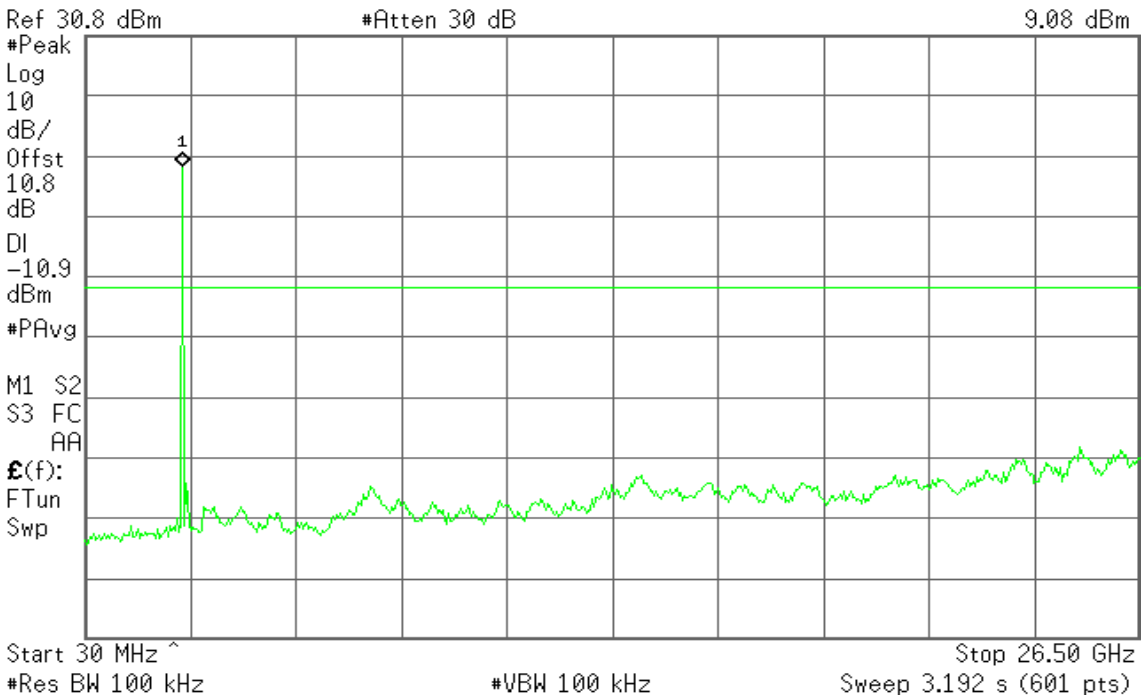



### CH High

Agilent

R T

Mkr1 2.50 GHz  
7.40 dBm

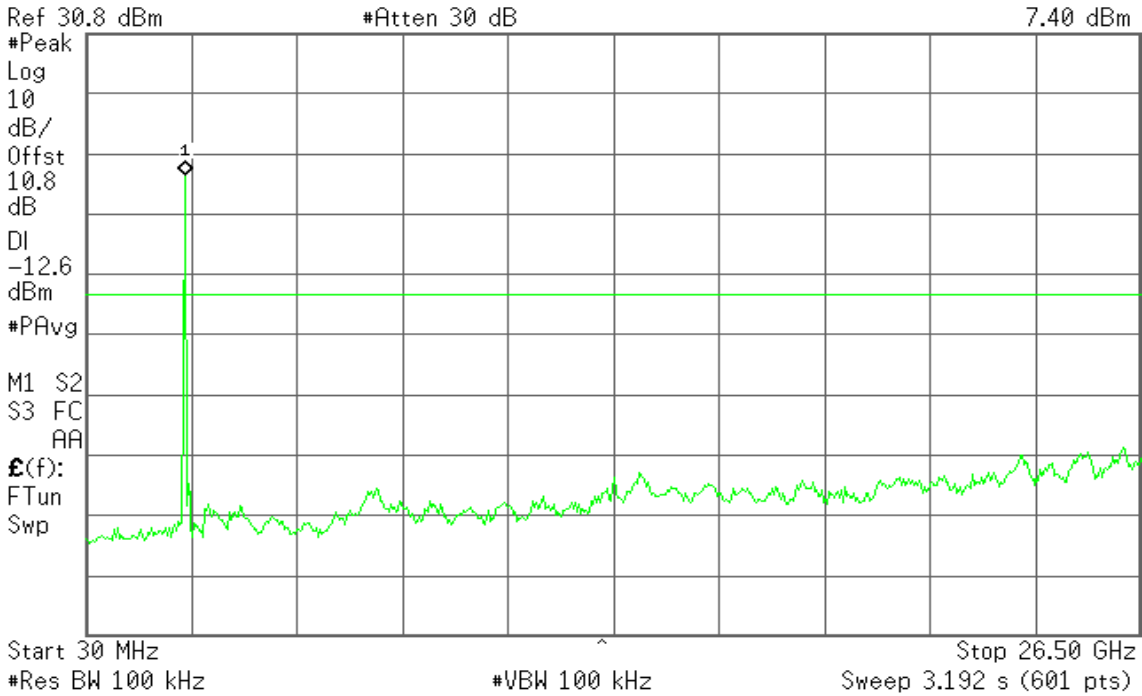

### 8DPSK

### CH Low

Agilent

R T

Mkr1 2.41 GHz  
5.00 dBm

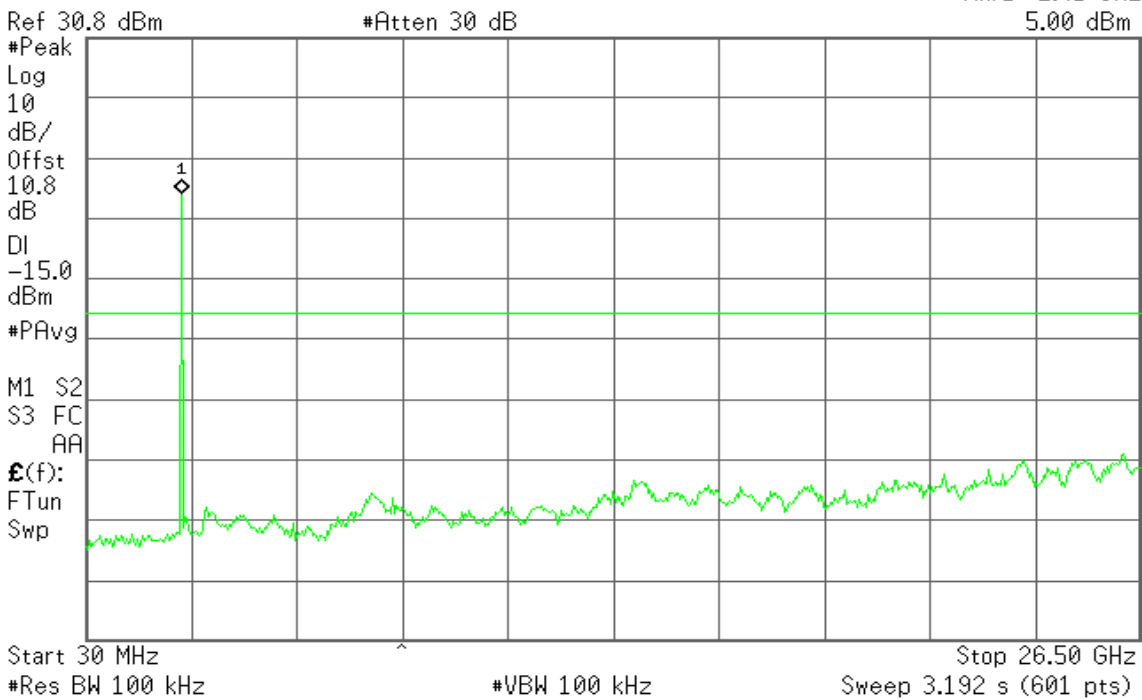



### CH Mid

Agilent

R T

Mkr1 2.46 GHz  
8.11 dBm

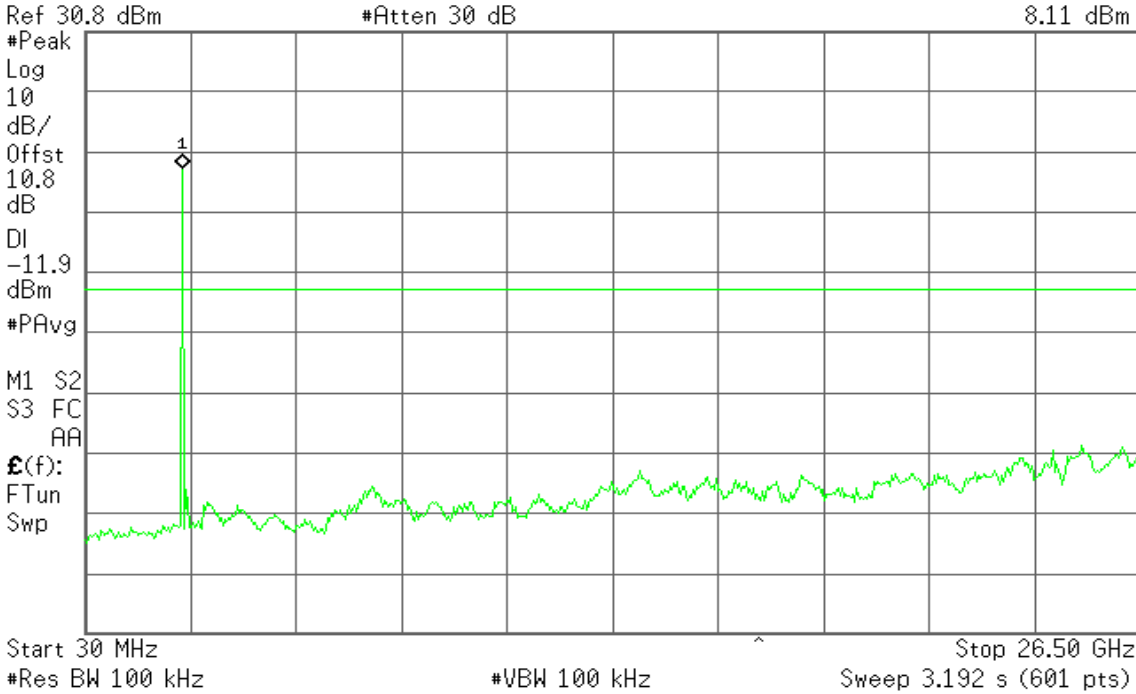

### CH High

Agilent

R T

Mkr1 2.50 GHz  
5.84 dBm

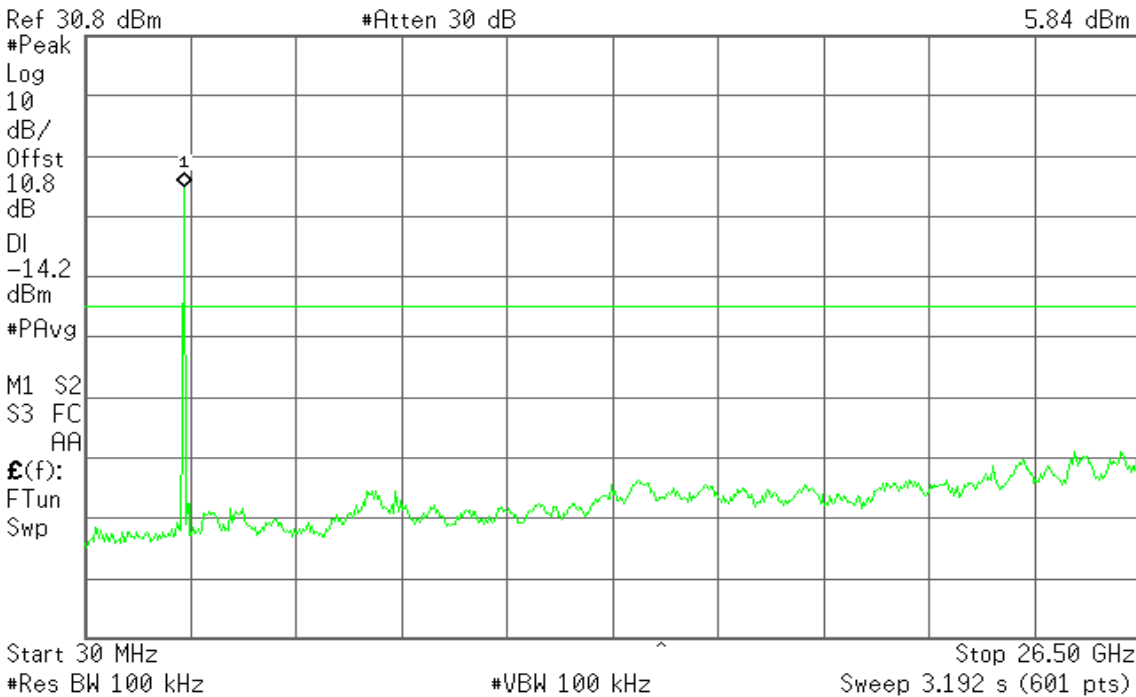



## 7.8.2 RADIATED EMISSIONS

### LIMIT

1. According to §15.209(a), except as provided elsewhere in this Subpart, the emissions from an intentional radiator shall not exceed the field strength levels specified in the following table:

Frequency (MHz)	Field Strength (µV/m)	Measurement Distance (m)
0.009-0.490	2400/F(kHz)	300
0.490-1.705	24000/F(kHz)	30
1.705-30.0	30	30
30-88	100*	3
88-216	150*	3
216-960	200*	3
Above 960	500	3

**Remark:** Except as provided in paragraph (g), fundamental emissions from intentional radiators operating under this Section shall not be located in the frequency bands 54-72 MHz, 76-88 MHz, 174-216 MHz or 470-806 MHz. However, operation within these frequency bands is permitted under other sections of this Part, e.g., Sections 15.231 and 15.241.

2. In the emission table above, the tighter limit applies at the band edges.

Frequency (Hz)	Field Strength (µV/m at 3-meter)	Field Strength (dBµV/m at 3-meter)
30-88	100	40
88-216	150	43.5
216-960	200	46
Above 960	500	54





## TEST CONFIGURATION

### Below 1 GHz

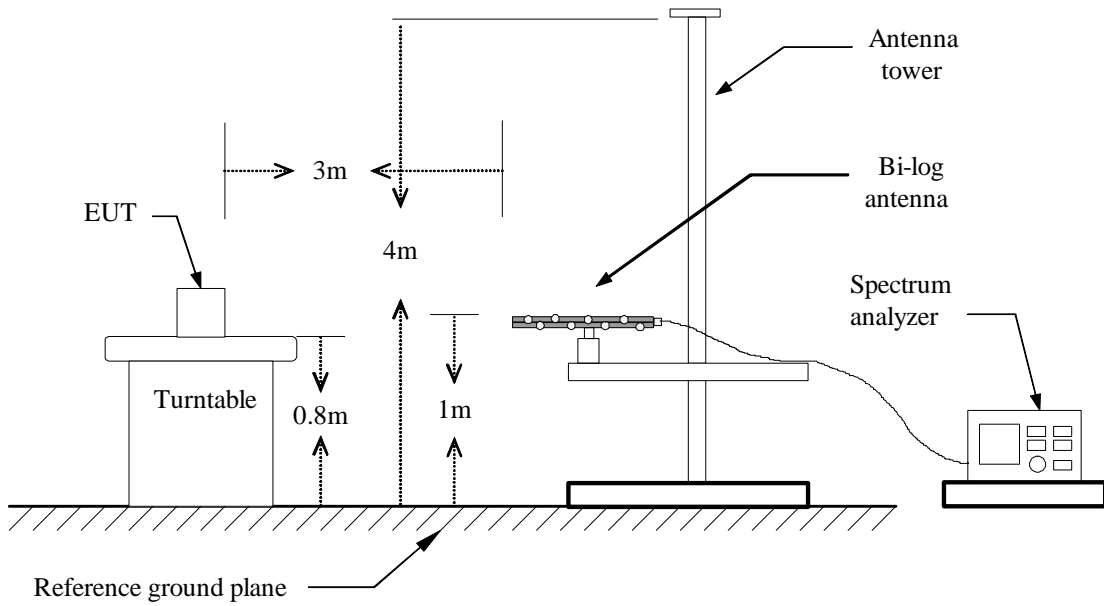

### Above 1 GHz

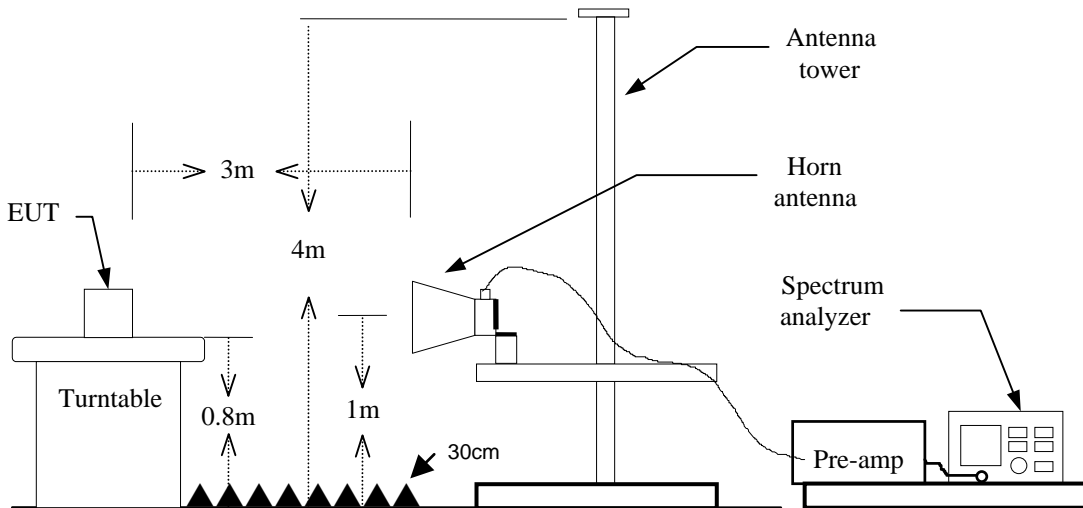



## **TEST PROCEDURE**

1. The EUT is placed on a turntable, which is 0.8m above ground plane.
2. The turntable shall be rotated for 360 degrees to determine the position of maximum emission level.
3. EUT is set 3m away from the receiving antenna, which is varied from 1m to 4m to find out the highest emissions.
4. Maximum procedure was performed on the six highest emissions to ensure EUT compliance.
5. And also, each emission was to be maximized by changing the polarization of receiving antenna both horizontal and vertical.
6. Set the spectrum analyzer in the following setting as:

### **Below 30MHz**

RBW=10kHz / VBW=30kHz / Sweep=AUTO

### **30 ~ 1000MHz:**

RBW=100kHz / VBW=300KHz / Sweep=AUTO

### **Above 1GHz:**

a) PEAK:RBW=1MHz VBW=RBW\*3 / Sweep=100ms

b) AVERAGE: RBW=1MHz / VBW=300Hz / Sweep=AUTO

7. Repeat above procedures until the measurements for all frequencies are complete.

In case the emission is lower than 30MHz. loop antenna has to be used for measurement and the recorded data should be QP measured by receiver. High - Low scan is not required in this case

## **TEST RESULTS**

### ***Below 1 GHz (9kHz ~ 30MHz)***

*No emission found between lowest internal used/generated frequency to 30MHz*

### ***Below 1 GHz (30 ~ 1000MHz)***

*No non-compliance noted*



**TEST DATA**

**Below 1 GHz**

<b>Operation Mode:</b>	Transmitting	<b>Test Date:</b>	2013/9/30
<b>Temperature:</b>	26°C	<b>Tested by:</b>	Louis Shen
<b>Humidity:</b>	56 % RH	<b>Polarity:</b>	Ver. / Hor.

Frequency (MHz)	Reading (dBuV)	Correction Factor (dB/m)	Result (dBuV/m)	Limit (dBuV/m)	Margin (dB)	Ant. Pol. (H/V)	Remark
35.8200	22.00	-11.29	10.71	40.00	-29.29	V	QP
75.2000	35.30	-20.45	14.85	40.00	-25.15	V	QP
647.9900	51.80	-7.00	44.80	46.00	-1.20	V	QP
678.8500	32.90	-6.82	26.08	46.00	-19.92	V	QP
699.3000	27.91	-6.72	21.19	46.00	-24.81	V	QP
771.4254	39.50	-5.50	34.00	46.00	-12.00	V	QP
894.8600	34.00	-3.54	30.46	46.00	-15.54	V	QP
36.0168	50.30	-11.40	38.90	40.00	-1.10	H	QP
75.1000	51.00	-20.46	30.54	40.00	-9.46	H	QP
92.5500	46.50	-17.72	28.78	43.50	-14.72	H	QP
339.4300	36.70	-11.13	25.57	46.00	-20.43	H	QP
647.9967	41.10	-7.00	34.10	46.00	-11.90	H	QP
802.3000	43.00	-5.07	37.93	46.00	-8.07	H	QP
898.6500	33.70	-3.47	30.23	46.00	-15.77	H	QP

**Remark:**

1. No emission found between lowest internal used / generated frequency to 30 MHz. (9kHz ~ 30MHz)
2. Measuring frequencies from 30 MHz to the 1GHz.
3. Radiated emissions measured in frequency range from 30 MHz to 1000MHz were made with an instrument using Peak detector mode.
4. Data of measurement within this frequency range shown " --- " in the table above means the reading of emissions are attenuated more than 20dB below the permissible limits or the field strength is too small to be measured.
5. The IF bandwidth of SPA between 30MHz to 1GHz was 100kHz.



**Above 1 GHz**

**GFSK**

<b>Operation Mode:</b>	TX / CH Low	<b>Test Date:</b>	2013/10/8
<b>Temperature:</b>	26°C	<b>Tested by:</b>	Francis Lee
<b>Humidity:</b>	56% RH	<b>Polarity:</b>	Ver. / Hor.

Freq. (MHz)	Reading (dBuV)	Correct Factor (dB/m)	Result (dBuV/m)	Limit (dBuV/m)	Margin (dB)	Ant. Pol H/V	Remark
1598.000	52.44	-4.80	47.64	74.00	-26.36	V	peak
2340.000	57.04	-1.60	55.44	74.00	-18.56	V	peak
2340.000	38.62	-1.60	37.02	54.00	-16.98	V	AVG
2380.000	56.62	-1.65	54.97	74.00	-19.03	V	peak
2380.000	38.67	-1.65	37.02	54.00	-16.98	V	AVG
2506.000	56.34	-1.00	55.34	74.00	-18.66	V	peak
2506.000	38.67	-1.00	37.67	54.00	-16.33	V	AVG
3815.000	36.55	3.36	39.91	74.00	-34.09	V	peak
5010.000	35.03	5.23	40.26	74.00	-33.74	V	peak
7650.000	34.78	11.34	46.12	74.00	-27.88	V	peak
1412.000	53.44	-7.15	46.29	74.00	-27.71	H	peak
2126.000	51.90	-3.72	48.18	74.00	-25.82	H	peak
2516.000	52.38	-3.74	48.64	74.00	-25.36	H	peak
3885.000	37.30	5.20	42.50	74.00	-31.50	H	peak
4685.000	34.62	7.10	41.72	74.00	-32.28	H	peak
7315.000	33.40	11.74	45.14	74.00	-28.86	H	peak

**Remark:**

1. Measuring frequencies from 1 GHz to the 10th harmonic of highest fundamental frequency.
2. Radiated emissions measured in frequency above 1000MHz were made with an instrument using peak/average detector mode.
3. Average test would be performed if the peak result were greater than the average limit or as required by the applicant.
4. Data of measurement within this frequency range shown " --- " in the table above means the reading of emissions are attenuated more than 20dB below the permissible limits or the field strength is too small to be measured.
5. Measurements above show only up to 6 maximum emissions noted, or would be lesser, with " N/A " remark, if no specific emissions from the EUT are recorded (ie: margin>20dB from the applicable limit) and considered that's already beyond the background noise floor.
6. Margin (dB) = Remark result (dBuV/m) – Average limit (dBuV/m).



## Compliance Certification Services Inc.

Report No.: T130822L04-RP2    FCC ID: M82-TREK520    Date of Issue: October 30, 2013

**Operation Mode:** TX / CH Mid                      **Test Date:** 2013/10/7~8  
**Temperature:** 26°C                                      **Tested by:** Francis Lee  
**Humidity:** 56% RH                                      **Polarity:** Ver. / Hor.

Freq. (MHz)	Reading (dBuV)	Correct Factor (dB/m)	Result (dBuV/m)	Limit (dBuV/m)	Margin (dB)	Ant. Pol H/V	Remark
1998.000	50.92	-1.33	49.59	74.00	-24.41	V	peak
2340.000	57.04	-1.60	55.44	74.00	-18.56	V	peak
2340.000	38.67	-1.60	37.07	54.00	-16.93	V	AVG
2380.000	56.62	-1.65	54.97	74.00	-19.03	V	peak
2380.000	38.29	-1.65	36.64	54.00	-17.36	V	AVG
2506.000	56.34	-1.00	55.34	74.00	-18.66	V	peak
2506.000	38.55	-1.00	37.55	54.00	-16.45	V	AVG
3725.000	36.70	2.78	39.48	74.00	-34.52	V	peak
5185.000	35.08	5.36	40.44	74.00	-33.56	V	peak
7595.000	34.19	11.89	46.08	74.00	-27.92	V	peak
1402.000	51.82	-6.94	44.88	74.00	-29.12	H	peak
2126.000	51.40	-3.72	47.68	74.00	-26.32	H	peak
2844.000	50.52	-2.15	48.37	74.00	-25.63	H	peak
3865.000	36.23	5.18	41.41	74.00	-32.59	H	peak
5575.000	34.65	9.11	43.76	74.00	-30.24	H	peak
7700.000	36.05	9.09	45.14	74.00	-28.86	H	peak

**Remark:**

1. Measuring frequencies from 1 GHz to the 10th harmonic of highest fundamental frequency.
2. Radiated emissions measured in frequency above 1000MHz were made with an instrument using peak/average detector mode.
3. Average test would be performed if the peak result were greater than the average limit or as required by the applicant.
4. Data of measurement within this frequency range shown " --- " in the table above means the reading of emissions are attenuated more than 20dB below the permissible limits or the field strength is too small to be measured.
5. Measurements above show only up to 6 maximum emissions noted, or would be lesser, with " N/A " remark, if no specific emissions from the EUT are recorded (ie: margin>20dB from the applicable limit) and considered that's already beyond the background noise floor.
6.  $Margin (dB) = Remark\ result (dBuV/m) - Average\ limit (dBuV/m)$ .



**Compliance Certification Services Inc.**

Report No.: T130822L04-RP2    FCC ID: M82-TREK520    Date of Issue: October 30, 2013

**Operation Mode:** TX / CH High

**Test Date:** 2013/10/7

**Temperature:** 26°C

**Tested by:** Francis Lee

**Humidity:** 56% RH

**Polarity:** Ver. / Hor.

Freq. (MHz)	Reading (dBuV)	Correct Factor (dB/m)	Result (dBuV/m)	Limit (dBuV/m)	Margin (dB)	Ant. Pol H/V	Remark
1994.000	51.37	-1.39	49.98	74.00	-24.02	V	peak
2340.000	56.12	-1.60	54.52	74.00	-19.48	V	peak
2340.000	38.90	-1.60	37.30	54.00	-16.70	V	AVG
2380.000	58.35	-1.65	56.70	74.00	-17.30	V	peak
2380.000	39.14	-1.65	37.49	54.00	-16.51	V	AVG
2454.000	57.47	-1.27	56.20	74.00	-17.80	V	peak
2454.000	38.77	-1.27	37.50	54.00	-16.50	V	AVG
2748.000	50.94	-1.77	49.17	74.00	-24.83	V	peak
3800.000	36.23	3.69	39.92	74.00	-34.08	V	peak
5435.000	34.17	6.33	40.50	74.00	-33.50	V	peak
7655.000	35.65	11.28	46.93	74.00	-27.07	V	peak
1410.000	52.29	-7.11	45.18	74.00	-28.82	H	peak
2140.000	51.13	-3.69	47.44	74.00	-26.56	H	peak
2816.000	50.40	-2.36	48.04	74.00	-25.96	H	peak
4280.000	35.29	7.32	42.61	74.00	-31.39	H	peak
5640.000	34.87	8.76	43.63	74.00	-30.37	H	peak
7415.000	34.49	11.25	45.74	74.00	-28.26	H	peak

**Remark:**

1. Measuring frequencies from 1 GHz to the 10th harmonic of highest fundamental frequency.
2. Radiated emissions measured in frequency above 1000MHz were made with an instrument using peak/average detector mode.
3. Average test would be performed if the peak result were greater than the average limit or as required by the applicant.
4. Data of measurement within this frequency range shown " --- " in the table above means the reading of emissions are attenuated more than 20dB below the permissible limits or the field strength is too small to be measured.
5. Measurements above show only up to 6 maximum emissions noted, or would be lesser, with " N/A " remark, if no specific emissions from the EUT are recorded (ie: margin>20dB from the applicable limit) and considered that's already beyond the background noise floor.
6. Margin (dB) = Remark result (dBuV/m) – Average limit (dBuV/m).



**8DPSK**

<b>Operation Mode:</b>	TX / CH Low	<b>Test Date:</b>	2013/10/7~8
<b>Temperature:</b>	26°C	<b>Tested by:</b>	Francis Lee
<b>Humidity:</b>	56% RH	<b>Polarity:</b>	Ver. / Hor.

Freq. (MHz)	Reading (dBuV)	Correct Factor (dB/m)	Result (dBuV/m)	Limit (dBuV/m)	Margin (dB)	Ant. Pol H/V	Remark
1512.000	52.85	-5.20	47.65	74.00	-26.35	V	peak
2340.000	56.04	-1.60	54.44	74.00	-19.56	V	peak
2340.000	38.61	-1.60	37.01	54.00	-16.99	V	AVG
2382.000	56.33	-1.65	54.68	74.00	-19.32	V	peak
2382.000	38.68	-1.65	37.03	54.00	-16.97	V	AVG
2506.000	56.84	-1.00	55.84	74.00	-18.16	V	peak
2506.000	38.74	-1.00	37.74	54.00	-16.26	V	AVG
3805.000	36.48	3.58	40.06	74.00	-33.94	V	peak
5355.000	35.14	5.87	41.01	74.00	-32.99	V	peak
7605.000	34.65	11.85	46.50	74.00	-27.50	V	peak
1412.000	53.44	-7.15	46.29	74.00	-27.71	H	peak
2126.000	51.90	-3.72	48.18	74.00	-25.82	H	peak
2516.000	52.38	-3.74	48.64	74.00	-25.36	H	peak
4315.000	35.14	7.55	42.69	74.00	-31.31	H	peak
5600.000	35.02	9.20	44.22	74.00	-29.78	H	peak
7260.000	34.73	11.29	46.02	74.00	-27.98	H	peak

**Remark:**

1. Measuring frequencies from 1 GHz to the 10th harmonic of highest fundamental frequency.
2. Radiated emissions measured in frequency above 1000MHz were made with an instrument using peak/average detector mode.
3. Average test would be performed if the peak result were greater than the average limit or as required by the applicant.
4. Data of measurement within this frequency range shown " --- " in the table above means the reading of emissions are attenuated more than 20dB below the permissible limits or the field strength is too small to be measured.
5. Measurements above show only up to 6 maximum emissions noted, or would be lesser, with " N/A " remark, if no specific emissions from the EUT are recorded (ie: margin>20dB from the applicable limit) and considered that's already beyond the background noise floor.
6. Margin (dB) = Remark result (dBuV/m) – Average limit (dBuV/m).



**Compliance Certification Services Inc.**

Report No.: T130822L04-RP2    FCC ID: M82-TREK520    Date of Issue: October 30, 2013

**Operation Mode:** TX / CH Mid                      **Test Date:** 2013/10/7~8  
**Temperature:** 26°C                                      **Tested by:** Francis Lee  
**Humidity:** 56% RH                                      **Polarity:** Ver. / Hor.

Freq. (MHz)	Reading (dBuV)	Correct Factor (dB/m)	Result (dBuV/m)	Limit (dBuV/m)	Margin (dB)	Ant. Pol H/V	Remark
1616.000	51.69	-4.93	46.76	74.00	-27.24	V	peak
2340.000	57.04	-1.60	55.44	74.00	-18.56	V	peak
2340.000	38.81	-1.60	37.21	54.00	-16.79	V	AVG
2380.000	56.62	-1.65	54.97	74.00	-19.03	V	peak
2380.000	38.39	-1.65	36.74	54.00	-17.26	V	AVG
2506.000	56.34	-1.00	55.34	74.00	-18.66	V	peak
2506.000	38.29	-1.00	37.29	54.00	-16.71	V	AVG
3835.000	38.24	2.91	41.15	74.00	-32.85	V	peak
5695.000	36.48	5.94	42.42	74.00	-31.58	V	peak
7595.000	34.61	11.89	46.50	74.00	-27.50	V	peak
1442.000	54.17	-7.78	46.39	74.00	-27.61	H	peak
2156.000	52.75	-3.66	49.09	74.00	-24.91	H	peak
2784.000	50.43	-2.62	47.81	74.00	-26.19	H	peak
4270.000	35.95	7.16	43.11	74.00	-30.89	H	peak
5600.000	35.09	9.20	44.29	74.00	-29.71	H	peak
7325.000	35.39	11.69	47.08	74.00	-26.92	H	peak

**Remark:**

1. Measuring frequencies from 1 GHz to the 10th harmonic of highest fundamental frequency.
2. Radiated emissions measured in frequency above 1000MHz were made with an instrument using peak/average detector mode.
3. Average test would be performed if the peak result were greater than the average limit or as required by the applicant.
4. Data of measurement within this frequency range shown " --- " in the table above means the reading of emissions are attenuated more than 20dB below the permissible limits or the field strength is too small to be measured.
5. Measurements above show only up to 6 maximum emissions noted, or would be lesser, with " N/A " remark, if no specific emissions from the EUT are recorded (ie: margin>20dB from the applicable limit) and considered that's already beyond the background noise floor.
6. Margin (dB) = Remark result (dBuV/m) – Average limit (dBuV/m).





**Compliance Certification Services Inc.**

Report No.: T130822L04-RP2    FCC ID: M82-TREK520    Date of Issue: October 30, 2013

**Operation Mode:** TX / CH High                      **Test Date:** 2013/10/7~8  
**Temperature:** 26°C                                      **Tested by:** Francis Lee  
**Humidity:** 56% RH                                      **Polarity:** Ver. / Hor.

Freq. (MHz)	Reading (dBuV)	Correct Factor (dB/m)	Result (dBuV/m)	Limit (dBuV/m)	Margin (dB)	Ant. Pol H/V	Remark
1998.000	50.92	-1.33	49.59	74.00	-24.41	V	peak
2340.000	57.04	-1.60	55.44	74.00	-18.56	V	peak
2340.000	38.59	-1.60	36.99	54.00	-17.01	V	AVG
2380.000	56.62	-1.65	54.97	74.00	-19.03	V	peak
2380.000	38.87	-1.65	37.22	54.00	-16.78	V	AVG
2454.000	55.00	-1.27	53.73	74.00	-20.27	V	peak
2454.000	38.62	-1.27	37.35	54.00	-16.65	V	AVG
2506.000	56.34	-1.00	55.34	74.00	-18.66	V	peak
2506.000	38.82	-1.00	37.82	54.00	-16.18	V	AVG
3800.000	36.53	3.69	40.22	74.00	-33.78	V	peak
5435.000	34.35	6.33	40.68	74.00	-33.32	V	peak
7215.000	35.55	10.12	45.67	74.00	-28.33	V	peak
1472.000	52.39	-8.41	43.98	74.00	-30.02	H	peak
2140.000	51.13	-3.69	47.44	74.00	-26.56	H	peak
2886.000	50.62	-1.83	48.79	74.00	-25.21	H	peak
3830.000	37.14	5.14	42.28	74.00	-31.72	H	peak
6110.000	35.53	8.63	44.16	74.00	-29.84	H	peak
7110.000	35.90	10.37	46.27	74.00	-27.73	H	peak

**Remark:**

1. Measuring frequencies from 1 GHz to the 10th harmonic of highest fundamental frequency.
2. Radiated emissions measured in frequency above 1000MHz were made with an instrument using peak/average detector mode.
3. Average test would be performed if the peak result were greater than the average limit or as required by the applicant.
4. Data of measurement within this frequency range shown " --- " in the table above means the reading of emissions are attenuated more than 20dB below the permissible limits or the field strength is too small to be measured.
5. Measurements above show only up to 6 maximum emissions noted, or would be lesser, with " N/A " remark, if no specific emissions from the EUT are recorded (ie: margin>20dB from the applicable limit) and considered that's already beyond the background noise floor.
6. Margin (dB) = Remark result (dBuV/m) – Average limit (dBuV/m).



## **7.9. POWERLINE CONDUCTED EMISSIONS**

### **LIMIT**

For an intentional radiator which is designed to be connected to the public utility (AC) power line, the radio frequency voltage that is conducted back onto the AC power line on any frequency or frequencies within the band 150 kHz to 30 MHz shall not exceed 250 microvolts (The limit decreases linearly with the logarithm of the frequency in the range 0.15 MHz to 0.50 MHz). The limits at specific frequency range is listed as follows:

Frequency Range (MHz)	Limits (dB $\mu$ V)	
	Quasi-peak	Average
0.15 to 0.50	66 to 56	56 to 46
0.50 to 5	56	46
5 to 30	60	50

Compliance with this provision shall be based on the measurement of the radio frequency voltage between each power line (LINE and NEUTRAL) and ground at the power terminals.

### **TEST CONFIGURATION**

See test photographs attached in Appendix 1 for the actual connections between EUT and support equipment.

### **TEST PROCEDURE**

1. The EUT was placed on a table, which is 0.8m above ground plane.
2. Maximum procedure was performed on the six highest emissions to ensure EUT compliance.
3. Repeat above procedures until all frequency measured were complete.

### **TEST RESULTS**

The initial step in collecting conducted data is a spectrum analyzer peak scan of the measurement range. Significant peaks are then marked as shown on the following data page, and these signals are then quasi-peaked.

### **TEST DATA**

**Not applicable, because the EUT is not connected to AC Main Source directly.**



## 8 PHOTOGRAPHS OF TEST SETUP

### Radiated Emission Setup Photos

#### Below 1GHz





## Above 1GHz





## Conducted Emission Setup Photo

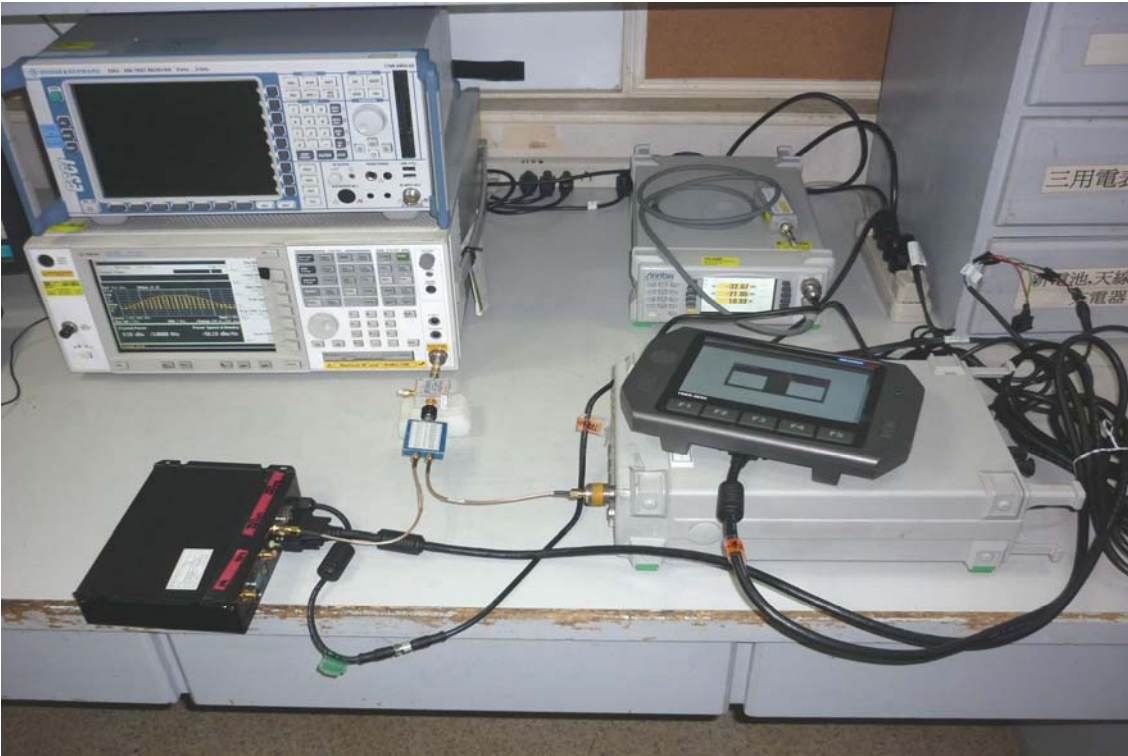



**APPENDIX 1: PHOTOGRAPHS OF EUT**  
**Refer to T130822L04 External Photographs.**