



FCC 47 CFR PART 22 SUBPART H AND PART 24 SUBPART E

TEST REPORT

For

Computer

Trade Name: ADVANTECH

**Model: TREK-753, TREK-753XXXXXXXXXXXXXXXXXX; X= (where “X”
may be any alphanumeric character , “-” or blank)**

Issued to

Advantech Co., Ltd.

**No.1, Alley 20, Lane 26, Rueiguang Road, Neihu District,
Taipei 114, Taiwan, R.O.C.**

Issued by

Compliance Certification Services Inc.

**No.11, Wu-Gong 6th Rd., Wugu Industrial Park,
New Taipei City 248, Taiwan (R.O.C.)**

<http://www.ccsrf.com>

service@ccsrf.com

Issued Date: February 1, 2012



Testing Laboratory
1309

Note: This report shall not be reproduced except in full, without the written approval of Compliance Certification Services Inc. This document may be altered or revised by Compliance Certification Services Inc. personnel only, and shall be noted in the revision section of the document.



Revision History

Rev.	Issue Date	Revisions	Effect Page	Revised By
00	February 1, 2012	Initial Issue	ALL	Sandy Lin



TABLE OF CONTENTS

1. TEST RESULT CERTIFICATION.....	4
2. EUT DESCRIPTION	5
3. TEST METHODOLOGY	6
3.1 EUT CONFIGURATION	6
3.2 EUT EXERCISE	6
3.3 GENERAL TEST PROCEDURES	6
3.4 DESCRIPTION OF TEST MODES	7
4. INSTRUMENT CALIBRATION.....	8
4.1 MEASURING INSTRUMENT CALIBRATION	8
4.2 MEASUREMENT EQUIPMENT USED	9
4.3 MEASUREMENT UNCERTAINTY	10
5. FACILITIES AND ACCREDITATIONS	11
5.1 FACILITIES	11
5.2 EQUIPMENT	11
5.3 TABLE OF ACCREDITATIONS AND LISTINGS	12
6. SETUP OF EQUIPMENT UNDER TEST	13
6.1 SETUP CONFIGURATION OF EUT	13
6.2 SUPPORT EQUIPMENT	13
7. FCC PART 22 & 24 REQUIREMENTS	14
7.1 TRANSMIT POWER.....	14
7.2 ERP & EIRP MEASUREMENT	16
7.3 OCCUPIED BANDWIDTH MEASUREMENT	19
7.4 OUT OF BAND EMISSION AT ANTENNA TERMINALS	26
7.5 FIELD STRENGTH OF SPURIOUS RADIATION MEASUREMENT	38
7.6 FREQUENCY STABILITY V.S. TEMPERATURE MEASUREMENT	64
7.7 FREQUENCY STABILITY V.S. VOLTAGE MEASUREMENT	67
7.8 POWERLINE CONDUCTED EMISSIONS	70
APPENDIX I PHOTOGRAPHS OF TEST SETUP.....	71
APPENDIX 1 - PHOTOGRAPHS OF EUT	



1. TEST RESULT CERTIFICATION

Applicant: Advantech Co., Ltd.
 No.1, Alley 20, Lane 26, Rueiguang Road,
 Neihu District, Taipei 114, Taiwan, R.O.C.

Equipment Under Test: Computer

Trade Name: ADVANTECH

Model: TREK-753, TREK-753XXXXXXXXXXXXXXXXXXXX; X= (where "X" may be any alphanumeric character, "-" or blank)

Date of Test: September 28 ~ 29, 2011

APPLICABLE STANDARDS	
STANDARD	TEST RESULT
FCC 47 CFR Part 22 Subpart H & Part 24 Subpart E	No non-compliance noted

We hereby certify that:

The above equipment was tested by Compliance Certification Services Inc. The test data, data evaluation, test procedures, and equipment configurations shown in this report were made in accordance with the procedures given in TIA/EIA-603-C: 2004 and the energy emitted by the sample EUT tested as described in this report is in compliance with conducted and radiated emission limits of FCC Rule FCC PART 22 Subpart H and PART 24 Subpart E.

The test results of this report relate only to the tested sample identified in this report.

Approved by:

Reviewed by:

Jason Lin
 Section Manager
 Compliance Certification Services Inc.

Gina Lo
 Section Manager
 Compliance Certification Services Inc.



2. EUT DESCRIPTION

Product	Computer
Trade Name	ADVANTECH
Model Number	TREK-753, TREK-753XXXXXXXXXXXXXXXXXX; X= (where "X" may be any alphanumeric character , "-" or blank)
Model Discrepancy	All the specification and layout are identical except they come with different model numbers for marketing purposes.
Received Date	Jane 16, 2011
Power Rating	Powered from Battery DC 12V/24V & 48V
Frequency Range	TX: 824.7 ~ 848.31 MHz / 1851.25 ~ 1908.75 MHz RX: 869.7 ~ 893.31 MHz / 1931.25 ~ 1988.75 MHz
Transmit Power (ERP & EIRP Power)	CDMA2000 1xRTT 850 MHz: Slide Mode: 20.79 dBm 1900 MHz: Slide Mode: 25.49 dBm CDMA2000 1xEVDO 850 MHz: Close Mode: 23.73 dBm 1900 MHz: Close Mode: 26.25 dBm
Cellular Phone Protocol	CDMA2000 1xRTT CDMA2000 1xEVDO
Type of Emission	CDMA2000 1xRTT: 824.7 ~ 848.31 MHz: 1M28F9W--- 1851.25 ~ 1908.75 MHz: 1M29F9W--- CDMA2000 1xEVDO 824.7 ~ 848.31 MHz: 1M28F9W--- 1851.25 ~ 1908.75 MHz: 1M29F9W---
Antenna Gain	850 MHz: -1.75dBi 1900 MHz: 7.62dBi
Antenna Type	Dipole Antenna

Remark:

1. The sample selected for test was engineering sample that approximated to production product and was provided by manufacturer.
2. This submittal(s) (test report) is intended for FCC ID: **M82-TREK-753** filing to comply with Part 22 and Part 24 of the FCC 47 CFR Rules.



3. TEST METHODOLOGY

Both conducted and radiated testing were performed according to the procedures document on chapter 13 of ANSI C63.4: 2003, TIA/EIA-603-C: 2004 and FCC CFR 47, 2.1046, 2.1047, 2.1049, 2.1051, 2.1053, 2.1055 and 2.1057.

3.1 EUT CONFIGURATION

The EUT configuration for testing is installed on RF field strength measurement to meet the Commissions requirement and operating in a manner that intends to maximize its emission characteristics in a continuous normal application.

3.2 EUT EXERCISE

The EUT was operated in the engineering mode to fix the TX frequency that was for the purpose of the measurements.

3.3 GENERAL TEST PROCEDURES

Conducted Emissions

The EUT is placed on the turntable, which is 0.8 m above ground plane. According to the requirements in Section 13.1.4.1 of ANSI C63.4. Conducted emissions from the EUT measured in the frequency range between 0.15 MHz and 30MHz using CISPR Quasi-peak and average detector modes.

Radiated Emissions

The EUT is placed on a turn table, which is 0.8 m above ground plane. The turntable shall rotate 360 degrees to determine the position of maximum emission level. EUT is set 3m away from the receiving antenna, which varied from 1m to 4m to find out the highest emission. And also, each emission was to be maximized by changing the polarization of receiving antenna both horizontal and vertical. In order to find out the maximum emissions, exploratory radiated emission measurements were made according to the requirements in Section 13.1.4.1 of ANSI C63.4.



3.4 DESCRIPTION OF TEST MODES

The EUT (model: TREK-753) had been tested under operating condition.

After verification, all tests were carried out with the worst case test modes as shown below except radiated spurious emission below 1GHz and power line conducted emissions below 30MHz, which worst case was in normal link mode only.

EUT staying in continuous transmitting mode was programmed.

Pre-scan was performed on RF conducted port to determine the worst-case scenario:

RC/TAP (REV)	SO/TAP (REV)	CDMA 850 / Cellular band			CDMA 1900 / PCS band		
		1013	384	777	25	600	1175
RC1	SO2	23.3	23.1	23.2	23.7	23.4	23.5
RC1	SO55	23.5	23.3	23.2	23.2	23.1	23.5
RC2	SO9	23.1	22.8	22.9	23.4	23.3	23.2
RC2	SO55	23.4	23.1	23.3	23.9	23.7	23.6
RC3	SO55	23.6	23.5	23.4	24.1	24	23.8
RC3	SO32	23.2	23.1	23.3	23.8	23.7	23.5
1xEvDO Rev.0	(FTAP) (dBm)	23.4	23.2	23.2	23.7	23.9	23.7

Based on the above results from the different modulations, CDMA2000 1xRTT RC3, SO32 (+F-SCH) and 1Xevdo, FTAP370 were determined to be the worst-case scenario for all tests.

The worst emission was found:

in lie-down (Y axis) for CDMA 2000 1xRTT cellular mode and CDMA2000 1xEVDO PCS mode, in lie-down (X axis) for CDMA2000 1xEVDO Cellular mode and CDMA2000 1xRTT PCS mode.



4. INSTRUMENT CALIBRATION

4.1 MEASURING INSTRUMENT CALIBRATION

The measuring equipment, which was utilized in performing the tests documented herein, has been calibrated in accordance with the manufacturer's recommendations for utilizing calibration equipment, which is traceable to recognized national standards.



4.2 MEASUREMENT EQUIPMENT USED

Equipment Used for Emissions Measurement

Remark: Each piece of equipment is scheduled for calibration once a year and Loop Antenna is scheduled for calibration once three years.

Conducted Emissions Test Site				
Name of Equipment	Manufacturer	Model	Serial Number	Calibration Due
Spectrum Analyzer	Agilent	E4446A	MY43360131	03/17/2012
Power Meter	Anritsu	ML2495A	1012009	04/27/2012
Power Sensor	Anritsu	MA2411A	0917072	04/27/2012
Temp. / Humidity Chamber	Terchy	MHG-150LF	930619	10/19/2012

Wugu 966 Chamber A				
Name of Equipment	Manufacturer	Model	Serial Number	Calibration Due
Spectrum Analyzer	Agilent	E4446A	US42510252	11/02/2012
EMI Test Receiver	R&S	ESCI	100064	02/17/2012
Pre-Amplifier	Mini-Circuits	ZFL-1000LN	SF350700823	01/12/2013
Pre-Amplifier	MITEQ	AFS44-00102650-42-10P-44	1415367	11/19/2012
Bilog Antenna	Sunol Sciences	JB3	A030105	10/03/2012
Bilog Antenna	Sunol Sciences	JB3	A030205	10/03/2012
Horn Antenna	EMCO	3117	00055165	01/11/2013
Horn Antenna	EMCO	3117	00055167	12/05/2012
Horn Antenna	EMCO	3116	00026370	10/12/2012
Loop Antenna	EMCO	6502	8905/2356	06/10/2013
Turn Table	CCS	CC-T-1F	N/A	N.C.R
Antenna Tower	CCS	CC-A-1F	N/A	N.C.R
Controller	CCS	CC-C-1F	N/A	N.C.R
Site NSA	CCS	N/A	N/A	12/25/2012
Site NSA	CCS	N/A	N/A	12/25/2012
Test S/W	EZ-EMC (CCS-3A1RE)			



4.3 MEASUREMENT UNCERTAINTY

PARAMETER	UNCERTAINTY
Powerline Conducted Emission	N/A
3M Semi Anechoic Chamber / 30M~200M	+/- 4.0138
3M Semi Anechoic Chamber / 200M~1000M	+/- 3.9483
3M Semi Anechoic Chamber / 1G~8G	+/- 2.5975
3M Semi Anechoic Chamber / 8G~18G	+/- 2.6112
3M Semi Anechoic Chamber / 18G~26G	+/- 2.7389
3M Semi Anechoic Chamber / 26G~40G	+/- 2.9683

Remark: This uncertainty represents an expanded uncertainty expressed at approximately the 95% confidence level using a coverage factor of $k=2$.



5. FACILITIES AND ACCREDITATIONS

5.1 FACILITIES

All measurement facilities used to collect the measurement data are located at

No.199, Chunghsen Road, Hsintien City, Taipei Hsien, Taiwan, R.O.C.

Tel: 886-2-2217-0894 / Fax: 886-2-2217-1029

No.11, Wu-Gong 6th Rd., Wugu Industrial Park, New Taipei City 248, Taiwan (R.O.C.)

Tel: 886-2-2299-9720 / Fax: 886-2-2298-4045

No.81-1, Lane 210, Bade 2nd Rd., Lujhu Township, Taoyuan County 33841, TAIWAN, R.O.C.

Tel: 886-3-324-0332 / Fax: 886-3-324-5235

The sites are constructed in conformance with the requirements of ANSI C63.7, ANSI C63.4 and CISPR Publication 22.

5.2 EQUIPMENT

Radiated emissions are measured with one or more of the following types of linearly polarized antennas: tuned dipole, biconical, log periodic, bi-log, and/or ridged waveguide, horn. Spectrum analyzers with pre-selectors and quasi-peak detectors are used to perform radiated measurements.



Conducted emissions are measured with Line Impedance Stabilization Networks and EMI Test Receivers.

Calibrated wideband preamplifiers, coaxial cables, and coaxial attenuators are also used for making measurements.

All receiving equipment conforms to CISPR Publication 16-1, "Radio Interference Measuring Apparatus and Measurement Methods."



5.3 TABLE OF ACCREDITATIONS AND LISTINGS

Country	Agency	Scope of Accreditation	Logo
USA	FCC	3M Semi Anechoic Chamber (FCC MRA: TW1039) to perform FCC Part 15 measurements	 FCC MRA: TW1039
Taiwan	TAF	LP0002, RTTE01, FCC Method-47 CFR Part 15 Subpart C, D, E, RSS-210, RSS-310 IDA TS SRD, AS/NZS 4268, AS/NZS 4771, TS 12.1 & 12.2, ETSI EN 300 440-1, ETSI EN 300 440-2, ETSI EN 300 328, ETSI EN 300 220-1, ETSI EN 300 220-2, ETSI EN 301 893, ETSI EN 301 489-1/3/7/17 FCC OET Bulletin 65 + Supplement C, EN 50360, EN 50361, EN 50371, RSS 102, EN 50383, EN 50385, EN 50392, IEC 62209, CNS 14958-1, CNS 14959 FCC Method -47 CFR Part 15 Subpart B IEC / EN 61000-3-2, IEC / EN 61000-3-3, IEC / EN 61000-4-2/3/4/5/6/8/11	
Canada	Industry Canada	3M Semi Anechoic Chamber (IC 2324G-1 / IC 2324G-2) to perform	 IC 2324G-1 IC 2324G-2

* No part of this report may be used to claim or imply product endorsement by A2LA or any agency of the US Government.



6. SETUP OF EQUIPMENT UNDER TEST

6.1 SETUP CONFIGURATION OF EUT

See test photographs attached in Appendix I for the actual connections between EUT and support equipment.

6.2 SUPPORT EQUIPMENT

No.	Device Type	Brand	Model	Series No.	FCC ID	Data Cable	Power Cord
1.	8960 Series 10 Wireless Communication test set (Remote)	Agilent	E5515C	GB44051665	N/A	N/A	Unshielded, 1.8m

Remark:

1. All the equipment/cables were placed in the worst-case configuration to maximize the emission during the test.
2. Grounding was established in accordance with the manufacturer's requirements and conditions for the intended use.



7. FCC PART 22 & 24 REQUIREMENTS

7.1 TRANSMIT POWER

LIMIT

According to FCC §2.1046.

Test Configuration

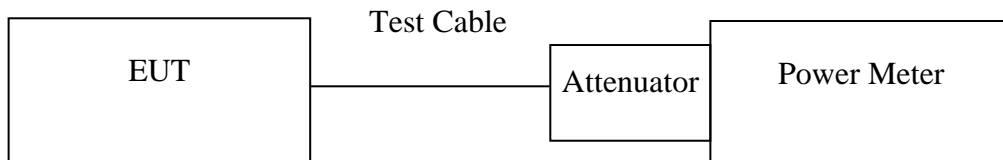

Remark: Measurement setup for testing on Antenna connector

TEST PROCEDURE

The transmitter output was connected to a calibrated attenuator, the other end of which was connected to a power meter. Transmitter output was read off the power meter in dBm. The power output at the transmitter antenna port was determined by adding the value of the attenuator to the power meter reading.

TEST RESULTS

No non-compliance noted.

**Test Data****Average Power**

Test Mode	CH	Frequency (MHz)	Average Power (dBm)
CDMA2000 1xRTT Cellular	1013	824.70	23.6
	384	836.52	23.5
	777	848.31	23.4
CDMA2000 1xEVDO Cellular	1013	824.70	23.4
	384	836.52	23.2
	777	848.31	23.2

Test Mode	CH	Frequency (MHz)	Average Power (dBm)
CDMA2000 1xRTT PCS	25	1851.25	24.1
	600	1880.00	24
	1175	1908.75	23.8
CDMA2000 1xEVDO PCS	25	1851.25	23.7
	600	1880.00	23.9
	1175	1908.75	23.7

Remark: The value of factor includes both the loss of cable and external attenuator

Peak Power

Test Mode	CH	Frequency (MHz)	Peak Power (dBm)
CDMA2000 1xRTT Cellular	1013	824.70	24.3
	384	836.52	24.1
	777	848.31	24.3
CDMA2000 1xEVDO Cellular	1013	824.70	24.8
	384	836.52	24.5
	777	848.31	24.6

Test Mode	CH	Frequency (MHz)	Peak Power (dBm)
CDMA2000 1xRTT PCS	25	1851.25	25.1
	600	1880.00	24.9
	1175	1908.75	24.6
CDMA2000 1xEVDO PCS	25	1851.25	24.2
	600	1880.00	24.8
	1175	1908.75	24.5

Remark: The value of factor includes both the loss of cable and external attenuator



7.2 ERP & EIRP MEASUREMENT

LIMIT

According to FCC §2.1046

FCC 22.913(b): The Effective Radiated Power (ERP) of mobile transmitters must not exceed 7 Watts.

FCC 24.232(b): The equivalent Isotropic Radiated Power (EIRP) must not exceed 2 Watts.

TEST CONFIGURATION

Below 1 GHz

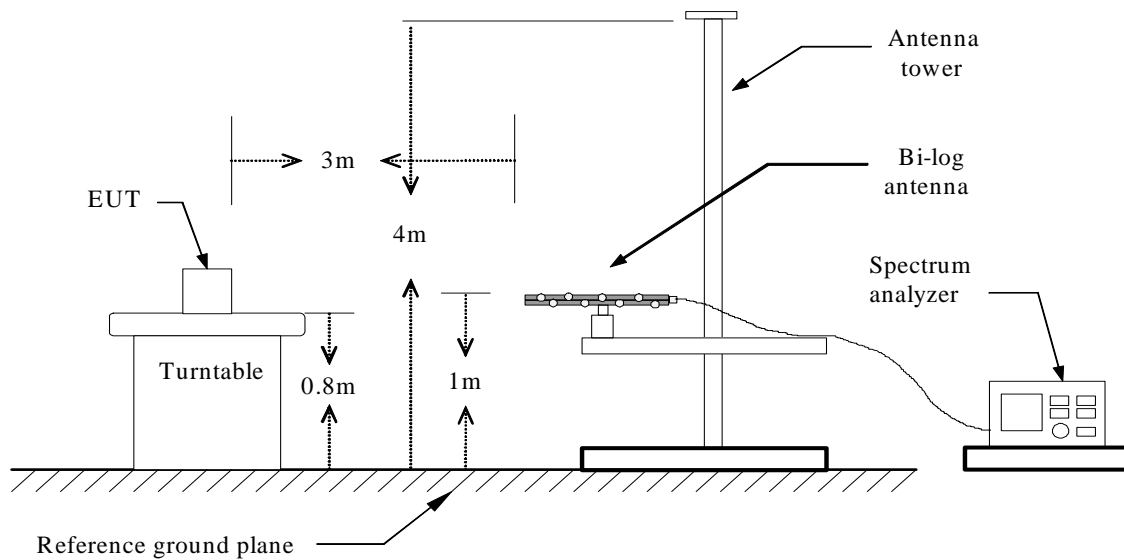

Above 1 GHz

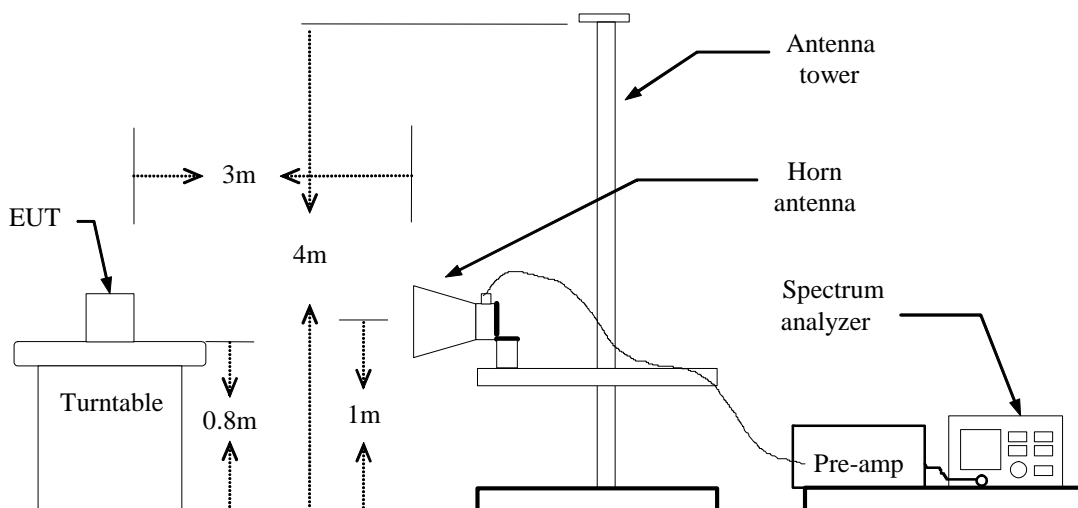



For Substituted Method Test Set-UP

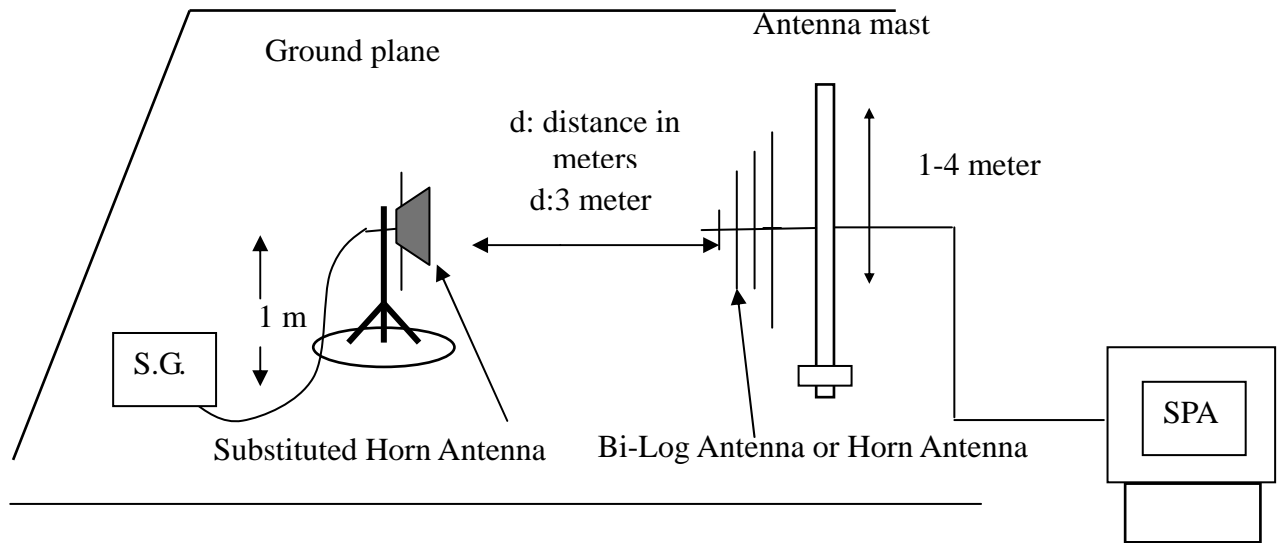

TEST PROCEDURE

The EUT was placed on a non-conductive turntable using a non-conductive support. The radiated emission at the fundamental frequency was measured at 3 m with a test antenna and EMI spectrum analyzer.

During the measurement of the EUT, the resolution bandwidth was set to 3MHz and the average bandwidth was set to 3MHz. The highest emission was recorded with the rotation of the turntable and the lowering of the test antenna. The reading was recorded and the field strength (E in dBuV/m) was calculated.

ERP in frequency band 824-849MHz, and EIRP in frequency band 1851.25 –1910MHz were measured using a substitution method. The EUT was replaced by half-wave dipole (824-849MHz) or horn antenna (1851.25-1910MHz) connected to a signal generator. The spectrum analyzer reading was recorded and ERP/EIRP was calculated as follows:

$$\text{ERP} = \text{S.G. output (dBm)} + \text{Antenna Gain (dBd)} - \text{Cable (dB)}$$

$$\text{EIRP} = \text{S.G. output (dBm)} + \text{Antenna Gain (dBi)} - \text{Cable (dB)}$$

**TEST RESULTS***No non-compliance noted.***CDMA2000 1xRTT Cellular Test Data**

Channel	Frequency (MHz)	Antenna Pol.	S.G. (dBm)	Cable loss (dB)	Ant.Gain (dBi)	Emission level (dBm)	Limit (dBm)	Margin (dB)
1013	824.70	V	16.83	3.39	6.24	19.68	38.45	-18.77
	824.70	H	13.99	3.39	6.24	16.84	38.45	-21.61
384	836.52	V	17.56	3.4	6.36	20.52	38.45	-17.93
	836.52	H	12.96	3.4	6.37	15.93	38.45	-22.52
777	848.31	V	17.79	3.4	6.4	*20.79	38.45	-17.66
	848.31	H	12.4	3.4	6.4	15.40	38.45	-23.05

CDMA2000 1xEVDO Cellular Test Data

Channel	Frequency (MHz)	Antenna Pol.	S.G. (dBm)	Cable loss (dB)	Ant.Gain (dBi)	Emission level (dBm)	Limit (dBm)	Margin (dB)
1013	824.70	V	7.99	3.39	6.24	10.84	38.45	-27.61
	824.70	H	18.99	3.39	6.24	21.84	38.45	-16.61
384	836.52	V	8.46	3.4	6.37	11.43	38.45	-27.02
	836.52	H	18.87	3.4	6.36	21.83	38.45	-16.62
777	848.31	V	8.43	3.4	6.4	11.43	38.45	-27.02
	848.31	H	20.73	3.4	6.4	*23.73	38.45	-14.72

CDMA2000 1xRTT PCS Test Data

Channel	Frequency (MHz)	Antenna Pol.	S.G. (dBm)	Cable loss (dB)	Ant.Gain (dBi)	Emission level (dBm)	Limit (dBm)	Margin (dB)
25	1851.25	V	16.95	5.37	5.67	17.25	33.00	-15.75
	1851.25	H	24.53	5.37	5.67	24.83	33.00	-8.17
600	1880.00	V	16.11	5.42	5.62	16.31	33.00	-16.69
	1880.00	H	25.29	5.42	5.62	*25.49	33.00	-7.51
1175	1908.75	V	15.53	5.47	5.56	15.62	33.00	-17.38
	1908.75	H	24.95	5.47	5.56	25.04	33.00	-7.96

CDMA2000 1xEVDO PCS Test Data

Channel	Frequency (MHz)	Antenna Pol.	S.G. (dBm)	Cable loss (dB)	Ant.Gain (dBi)	Emission level (dBm)	Limit (dBm)	Margin (dB)
25	1851.25	V	13.01	5.37	5.67	13.31	33.00	-19.69
	1851.25	H	21.97	5.37	5.67	22.27	33.00	-10.73
600	1880.00	V	16.13	5.42	5.62	16.33	33.00	-16.67
	1880.00	H	26.05	5.42	5.62	*26.25	33.00	-6.75
1175	1908.75	V	16.92	5.47	5.56	17.01	33.00	-15.99
	1908.75	H	25.8	5.47	5.56	25.89	33.00	-7.11



7.3 OCCUPIED BANDWIDTH MEASUREMENT

LIMIT

According to §FCC 2.1049.

Test Configuration

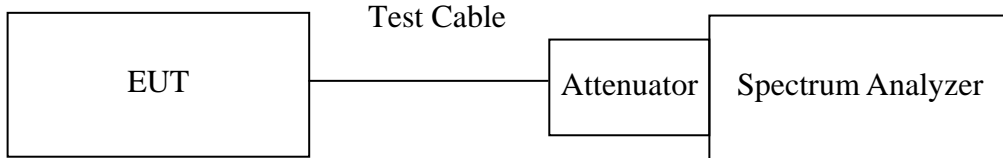

Remark: Measurement setup for testing on Antenna connector

TEST PROCEDURE

The EUT’s output RF connector was connected with a short cable to the spectrum analyzer, RBW was set to about 1% of emission BW, VBW is set to 3 times the RBW, -26dBc display line was placed on the screen (or 99% bandwidth), the occupied bandwidth is the delta frequency between the two points where the display line intersects the signal trace.

TEST RESULTS

No non-compliance noted.

Test Data

Test Mode	CH	Frequency (MHz)	Bandwidth (MHz)
CDMA2000 1xRTT Cellular	1013	824.70	1.2733
	384	836.52	1.2835
	777	848.31	1.2802
CDMA2000 1xEVDO Cellular	1013	824.70	1.2807
	384	836.52	1.2768
	777	848.31	1.2810

Test Mode	CH	Frequency (MHz)	Bandwidth (MHz)
CDMA2000 1xRTT PCS	25	1851.25	1.2963
	600	1880.00	1.2872
	1175	1908.75	1.2909
CDMA2000 1xEVDO PCS	25	1851.25	1.2942
	600	1880.00	1.2901
	1175	1908.75	1.2881



Test Plot

CDMA2000 1xRTT Cellular / CH Low

Agilent 15:01:18 Sep 29, 2011

R T

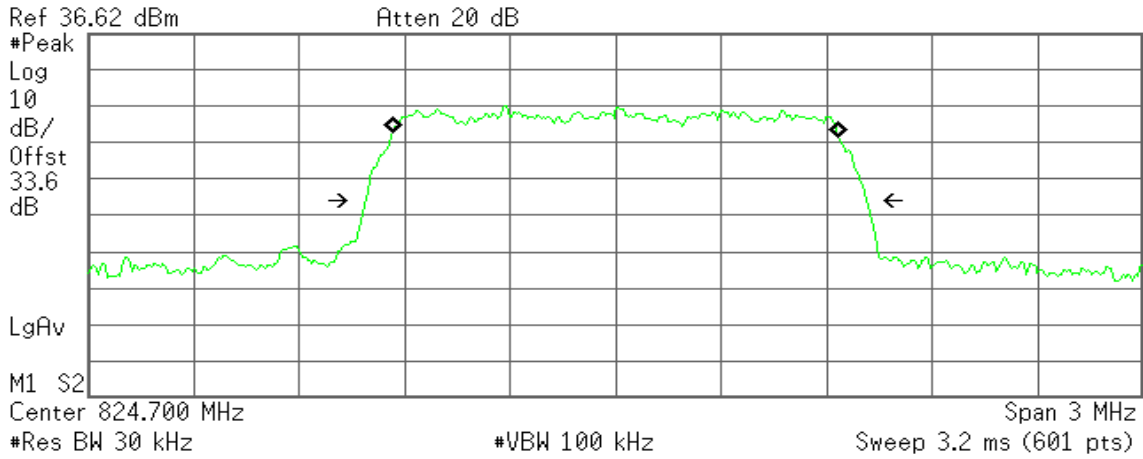

Occupied Bandwidth
1.2733 MHz

Occ BW % Pwr 99.00 %
x dB -26.00 dB

Transmit Freq Error -231.511 Hz
x dB Bandwidth 1.429 MHz

CDMA2000 1xRTT Cellular / CH Mid

Agilent 14:58:34 Sep 29, 2011

R T

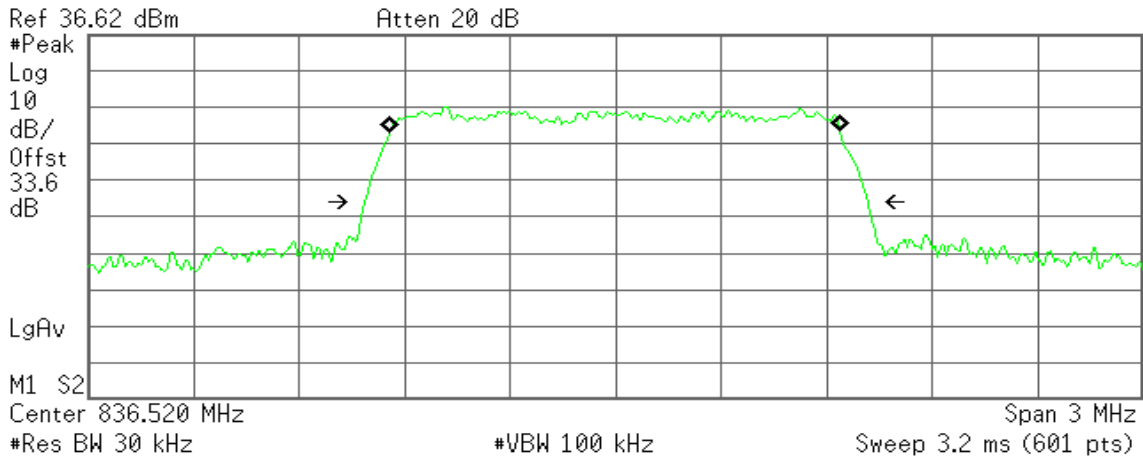

Occupied Bandwidth
1.2835 MHz

Occ BW % Pwr 99.00 %
x dB -26.00 dB

Transmit Freq Error -1.957 kHz
x dB Bandwidth 1.433 MHz



CDMA2000 1xRTT Cellular / CH High

Agilent 15:00:45 Sep 29, 2011

R T

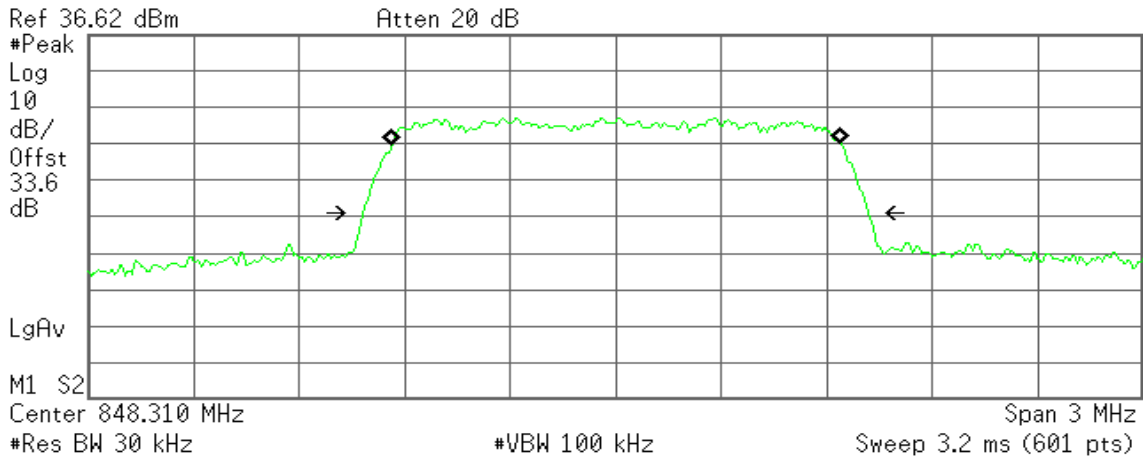

Occupied Bandwidth
1.2802 MHz

Occ BW % Pwr 99.00 %
x dB -26.00 dB

Transmit Freq Error 2.292 kHz
x dB Bandwidth 1.439 MHz

CDMA2000 1xEVDO Cellular / CH Low

Agilent 15:01:52 Sep 29, 2011

R T

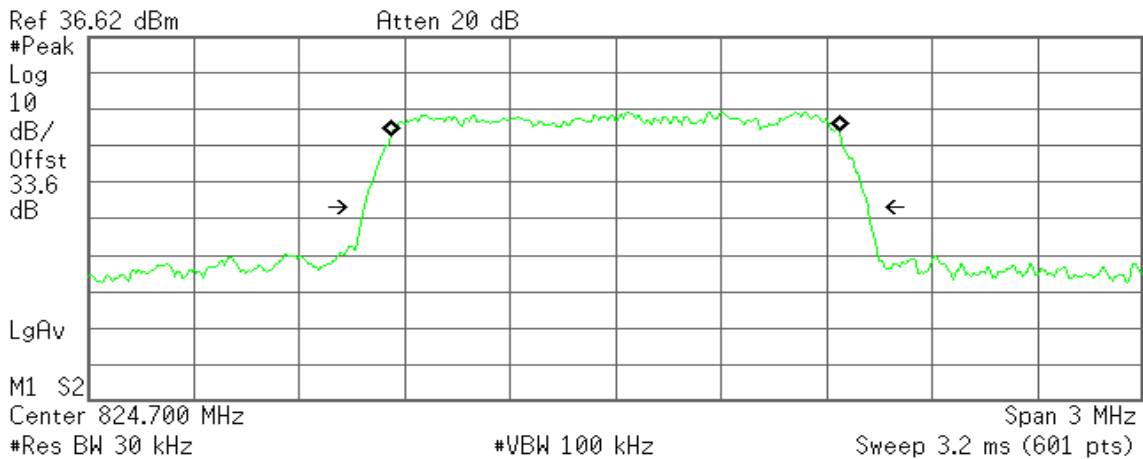

Occupied Bandwidth
1.2807 MHz

Occ BW % Pwr 99.00 %
x dB -26.00 dB

Transmit Freq Error -628.369 Hz
x dB Bandwidth 1.435 MHz



CDMA2000 1xEVDO Cellular / CH Mid

Agilent 14:59:38 Sep 29, 2011

R T

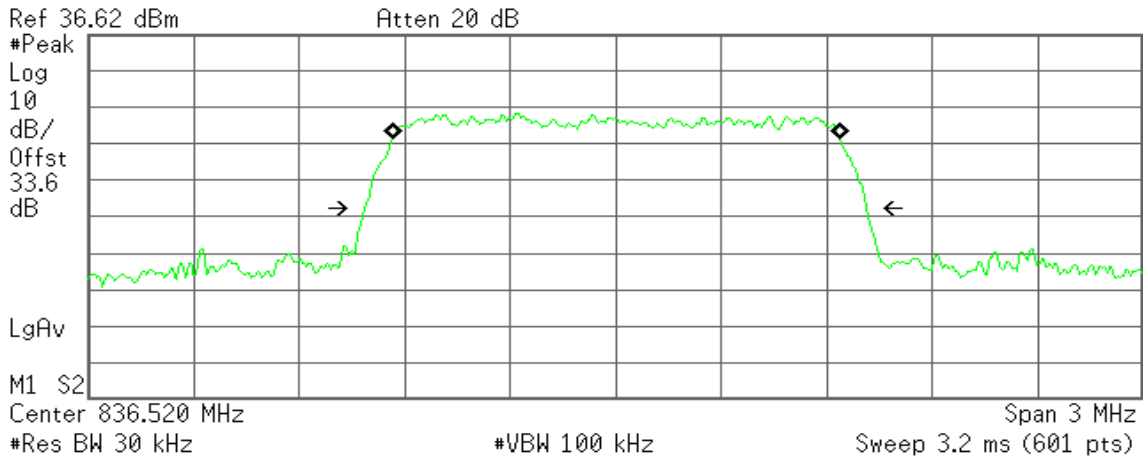

Occupied Bandwidth
1.2768 MHz

Occ BW % Pwr 99.00 %
x dB -26.00 dB

Transmit Freq Error 1.961 kHz
x dB Bandwidth 1.431 MHz

CDMA2000 1xEVDO Cellular / CH High

Agilent 15:00:10 Sep 29, 2011

R T

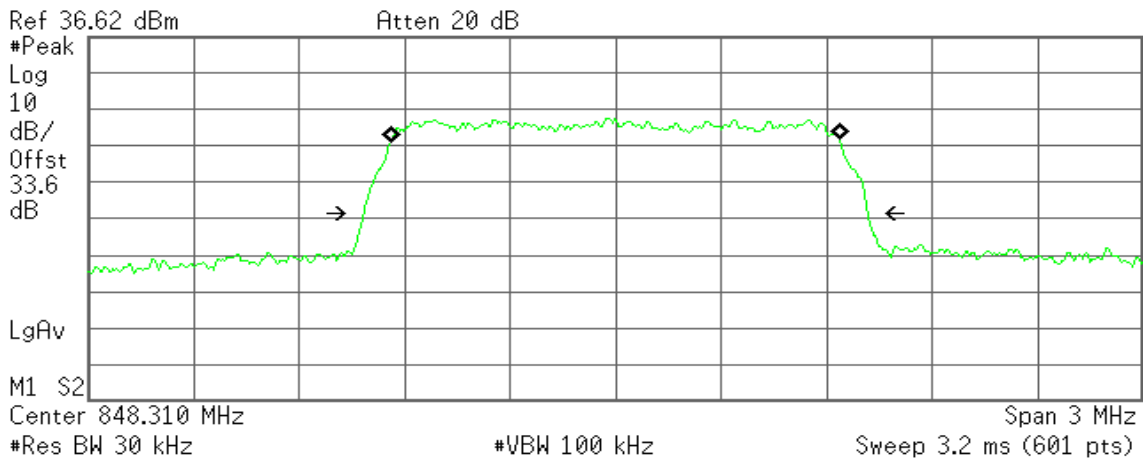

Occupied Bandwidth
1.2810 MHz

Occ BW % Pwr 99.00 %
x dB -26.00 dB

Transmit Freq Error 12.498 Hz
x dB Bandwidth 1.437 MHz



CDMA2000 1xRTT PCS / CH Low

Agilent 15:56:29 Sep 29, 2011

R T

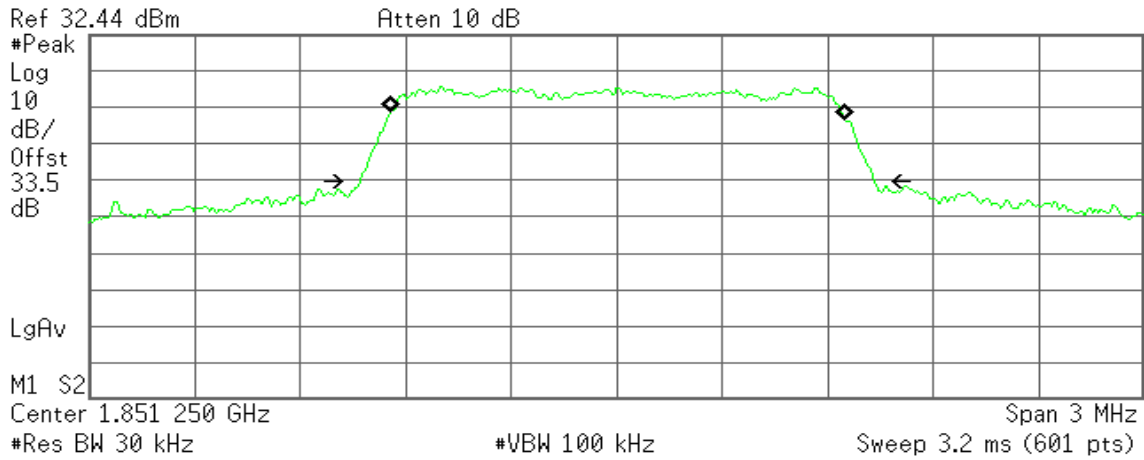

Occupied Bandwidth
1.2963 MHz

Occ BW % Pwr 99.00 %
x dB -26.00 dB

Transmit Freq Error 2.096 kHz
x dB Bandwidth 1.467 MHz

CDMA2000 1xRTT PCS / CH Mid

Agilent 15:58:21 Sep 29, 2011

R T

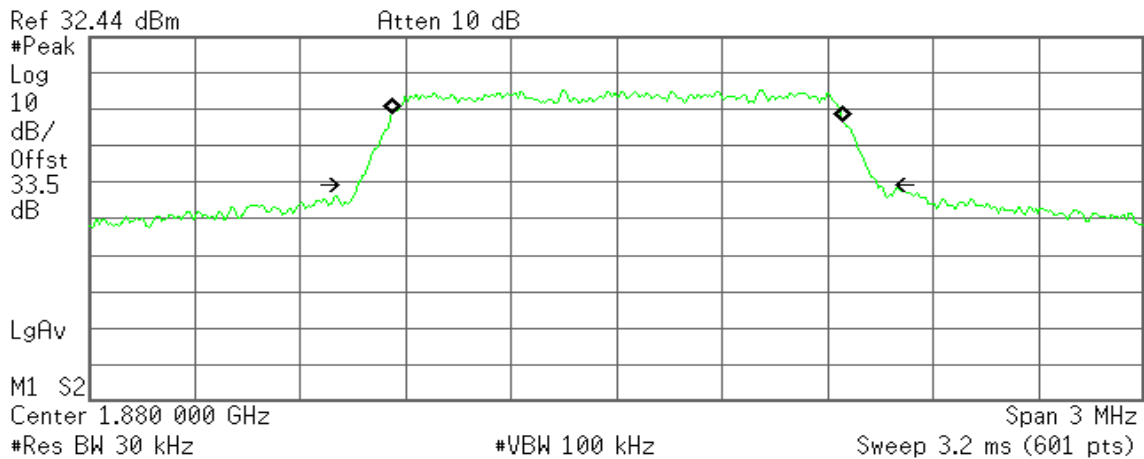

Occupied Bandwidth
1.2872 MHz

Occ BW % Pwr 99.00 %
x dB -26.00 dB

Transmit Freq Error 2.390 kHz
x dB Bandwidth 1.481 MHz



CDMA2000 1xRTT PCS / CH High

Agilent 16:00:59 Sep 29, 2011

R T

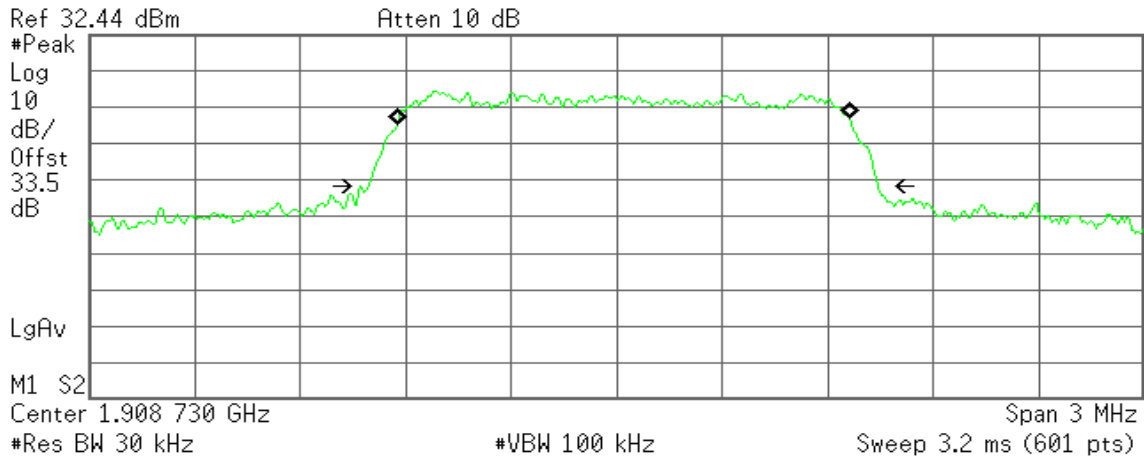

Occupied Bandwidth
1.2909 MHz

Occ BW % Pwr 99.00 %
x dB -26.00 dB

Transmit Freq Error 20.401 kHz
x dB Bandwidth 1.450 MHz

CDMA2000 1xEVDO PCS / CH Low

Agilent 15:57:31 Sep 29, 2011

R T

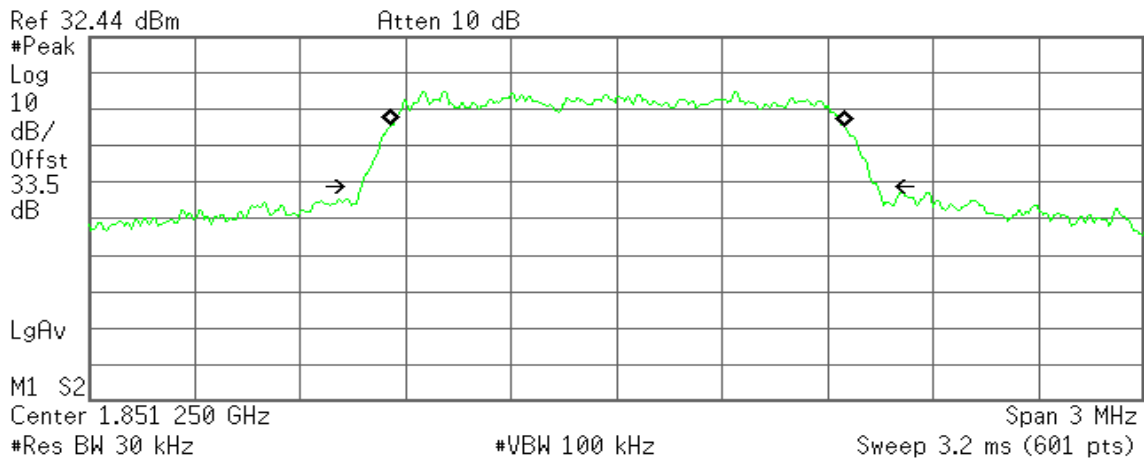

Occupied Bandwidth
1.2942 MHz

Occ BW % Pwr 99.00 %
x dB -26.00 dB

Transmit Freq Error 3.604 kHz
x dB Bandwidth 1.470 MHz



CDMA2000 1xEVDO PCS / CH Mid

Agilent 15:58:12 Sep 29, 2011

R T

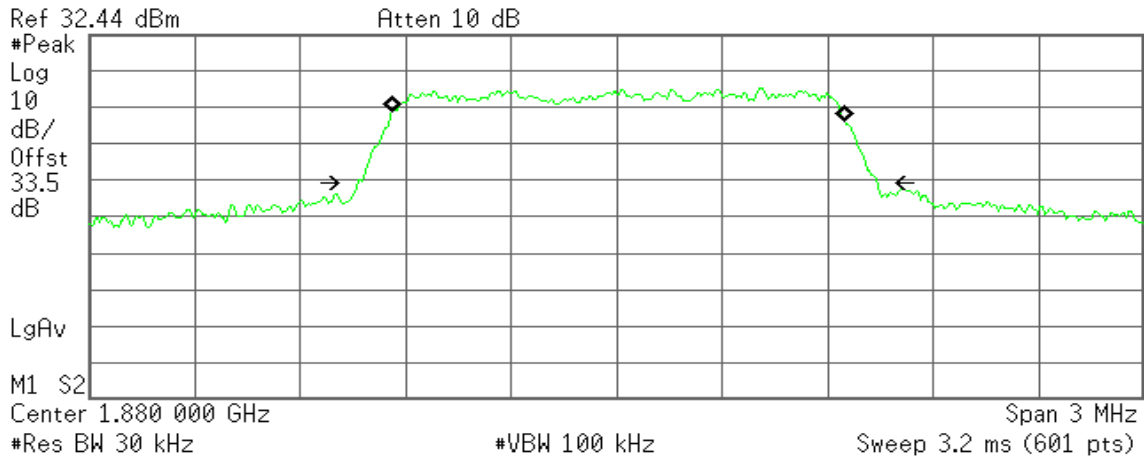

Occupied Bandwidth
1.2901 MHz

Occ BW % Pwr 99.00 %
x dB -26.00 dB

Transmit Freq Error 2.893 kHz
x dB Bandwidth 1.481 MHz

CDMA2000 1xEVDO PCS / CH High

Agilent 16:01:07 Sep 29, 2011

R T

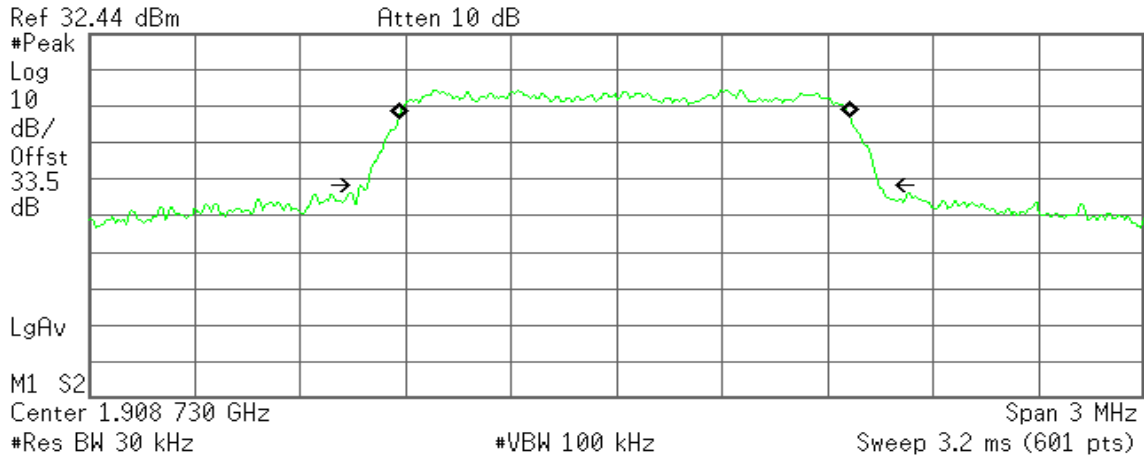

Occupied Bandwidth
1.2881 MHz

Occ BW % Pwr 99.00 %
x dB -26.00 dB

Transmit Freq Error 21.650 kHz
x dB Bandwidth 1.455 MHz



7.4 OUT OF BAND EMISSION AT ANTENNA TERMINALS

LIMIT

According to FCC §2.1051, FCC §22.917, FCC §24.238(a).

Out of Band Emissions: The mean power of emission must be attenuated below the mean power of the non-modulated carrier (P) on any frequency twice or more than twice the fundamental frequency by at least $43 + 10 \log P$ dB.

Mobile Emissions in Base Frequency Range: The mean power of any emissions appearing in the base station frequency range from cellular mobile transmitters operated must be attenuated to a level not exceed -80 dBm at the transmit antenna connector.

Band Edge Requirements: In the 1MHz bands immediately outside and adjacent to the frequency block, a resolution bandwidth of at least 1% of the emission bandwidth of the fundamental emission of the transmitter may be employed to measure the Out of band Emission

TEST CONFIGURATION

Out of band emission at antenna terminals:

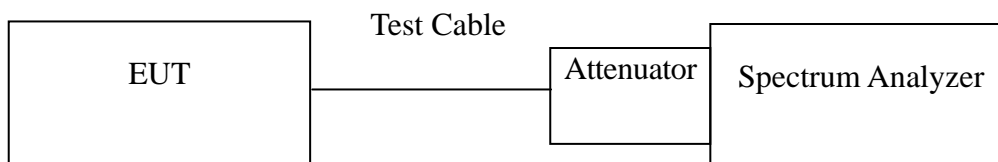

TEST PROCEDURE

The RF output of the transceiver was connected to a spectrum analyzer through appropriate attenuation. The resolution bandwidth of the spectrum analyzer was set at 1MHz, sufficient scans were taken to show the out of band Emissions if any up to 10th harmonic.

For the out of band: Set the RBW, VBW = 1MHz, Start=30MHz, Stop= 10 th harmonic. Limit = -13dBm

Band Edge Requirements (824 MHz and 849 MHz /1850MHz and 1910MHz): In the 1 MHz bands immediately outside and adjacent to the frequency block, a resolution bandwidth of at least 1 percent of the emission bandwidth of the fundamental emission of the transmitter may be employed to measure the out of band Emissions. Limit, -13dBm.

**TEST RESULTS***No non-compliance noted.***Test Data**

Mode	CH	Location	Description
CDMA2000 1xRTT Cellular	1013	Figure 7-1	Conducted spurious emissions, 30MHz - 20GHz
	384	Figure 7-2	Conducted spurious emissions, 30MHz - 20GHz
	777	Figure 7-3	Conducted spurious emissions, 30MHz - 20GHz
Mode	CH	Location	Description
CDMA2000 1xEVDO Cellular	1013	Figure 8-1	Conducted spurious emissions, 30MHz - 20GHz
	384	Figure 8-2	Conducted spurious emissions, 30MHz - 20GHz
	777	Figure 8-3	Conducted spurious emissions, 30MHz - 20GHz
Mode	CH	Location	Description
CDMA2000 1xRTT PCS	25	Figure 9-1	Conducted spurious emissions, 30MHz - 20GHz
	600	Figure 9-2	Conducted spurious emissions, 30MHz - 20GHz
	1175	Figure 9-3.	Conducted spurious emissions, 30MHz - 20GHz
Mode	CH	Location	Description
CDMA2000 1xEVDO PCS	25	Figure 10-1	Conducted spurious emissions, 30MHz - 20GHz
	600	Figure 10-2	Conducted spurious emissions, 30MHz - 20GHz
	1175	Figure 10-3.	Conducted spurious emissions, 30MHz - 20GHz
Mode	CH	Location	Description
CDMA2000 1xRTT Cellular	1013	Figure 11-1	Band Edge emissions
	384	Figure11-2	Band Edge emissions
Mode	CH	Location	Description
CDMA2000 1xEVDO Cellular	1013	Figure 12-1	Band Edge emissions
	384	Figure 12-2	Band Edge emissions
Mode	CH	Location	Description
CDMA2000 1xRTT PCS	25	Figure 13-1	Band Edge emissions
	1175	Figure 13-2	Band Edge emissions
Mode	CH	Location	Description
CDMA2000 1xEVDO PCS	25	Figure 14-1	Band Edge emissions
	1175	Figure 14-2	Band Edge emissions



Test Plot

CDMA2000 1xRTT Cellular

Figure 7-1: Out of Band emission at antenna terminals – CDMA2000 1xRTT / CH Low

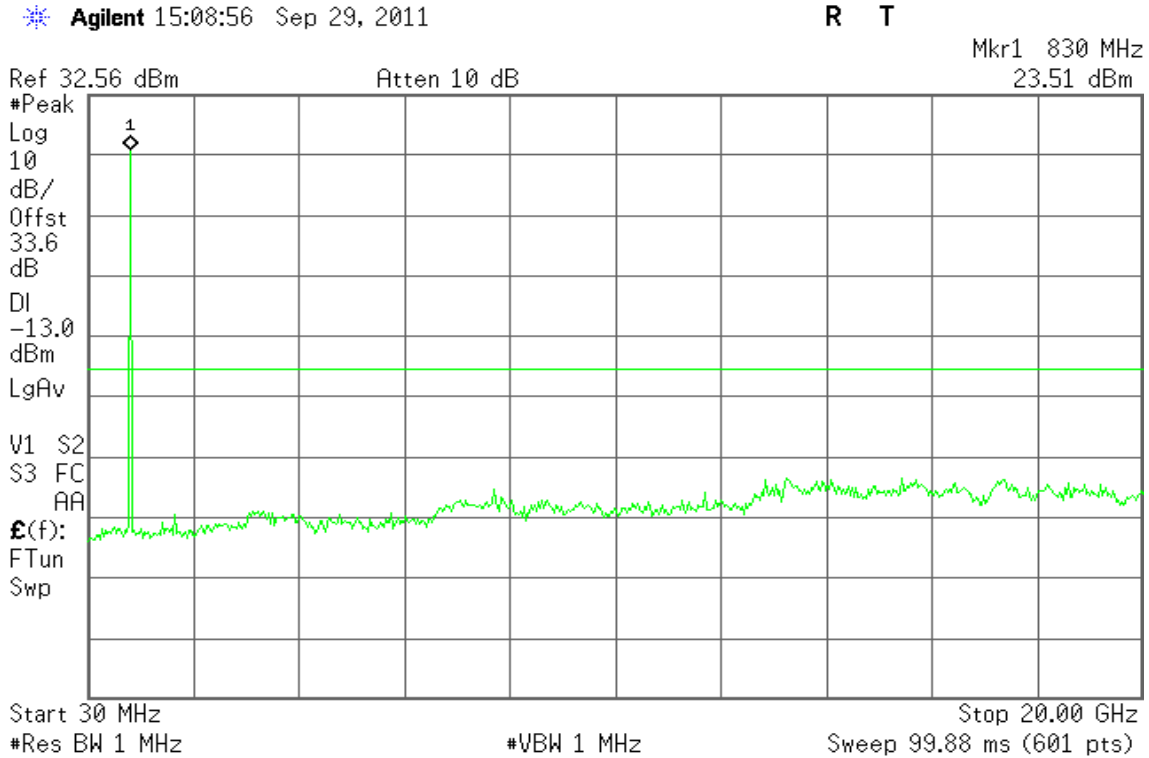

Figure 7-2: Out of Band emission at antenna terminals – CDMA2000 1xRTT / CH Mid

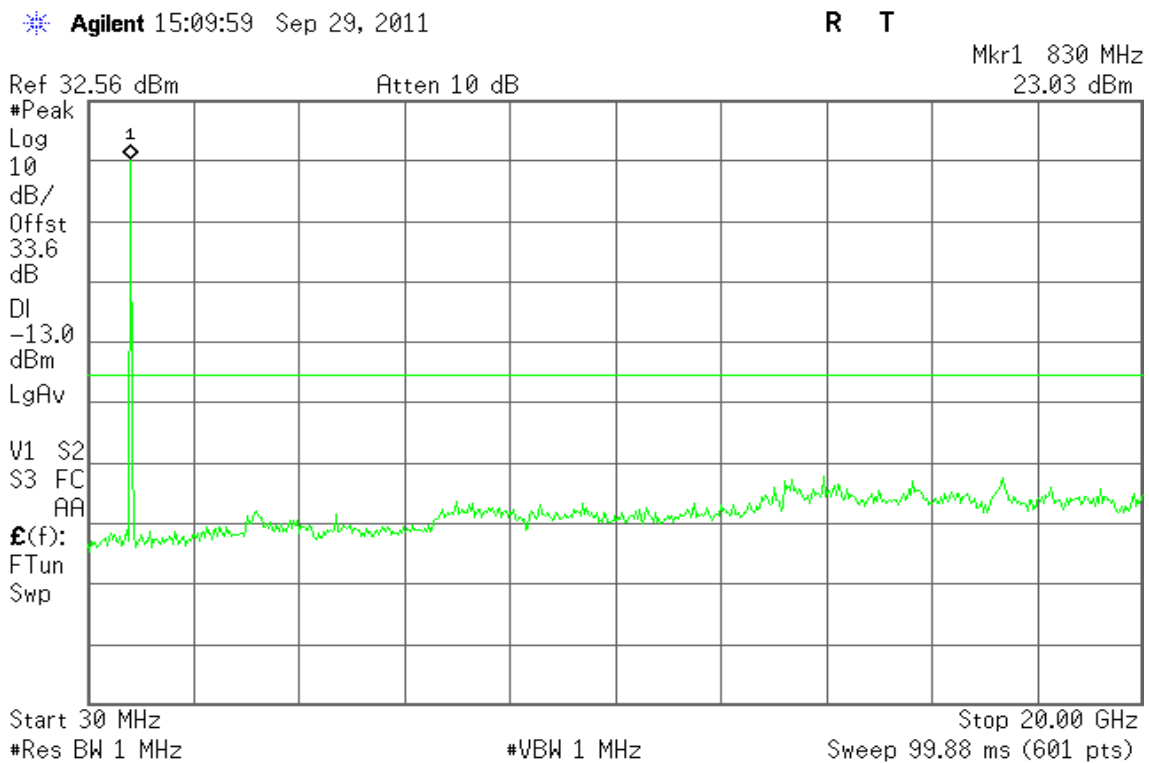
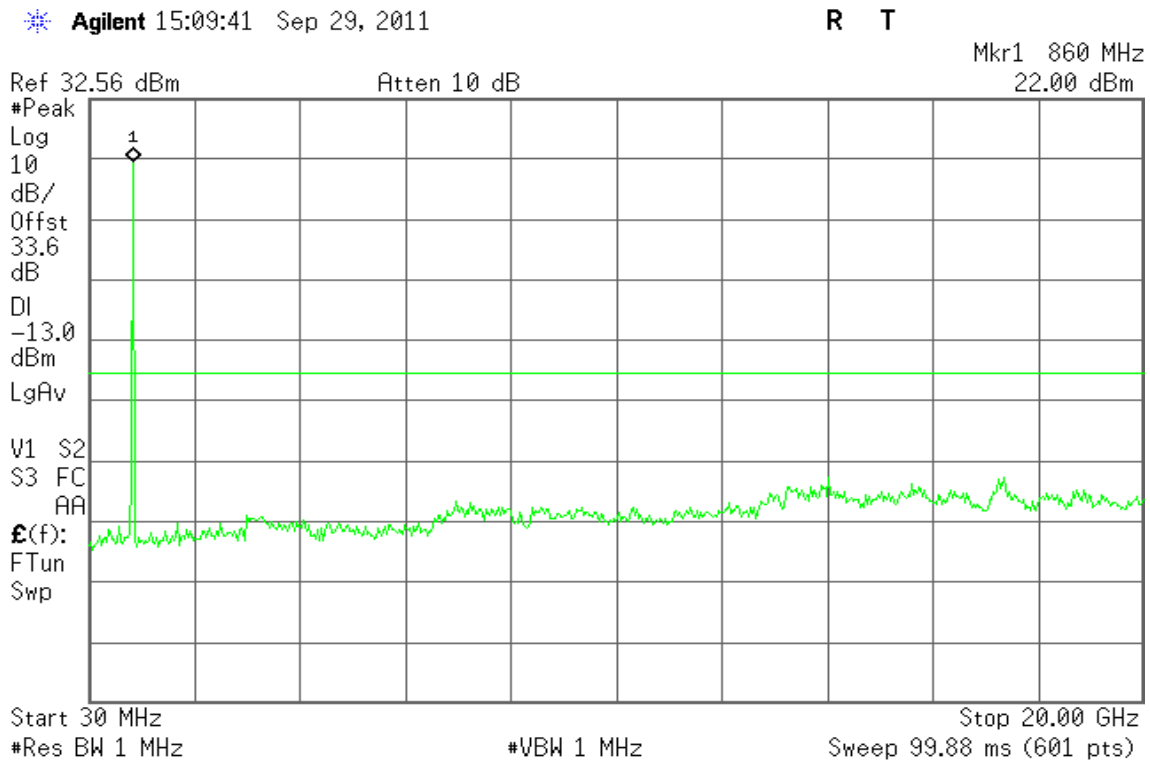



Figure 7-3: Out of Band emission at antenna terminals – CDMA2000 1xRTT / CH High



1xEVDO Cellular

Figure 8-1: Out of Band emission at antenna terminals – CDMA2000 1xEVDO / CH Low

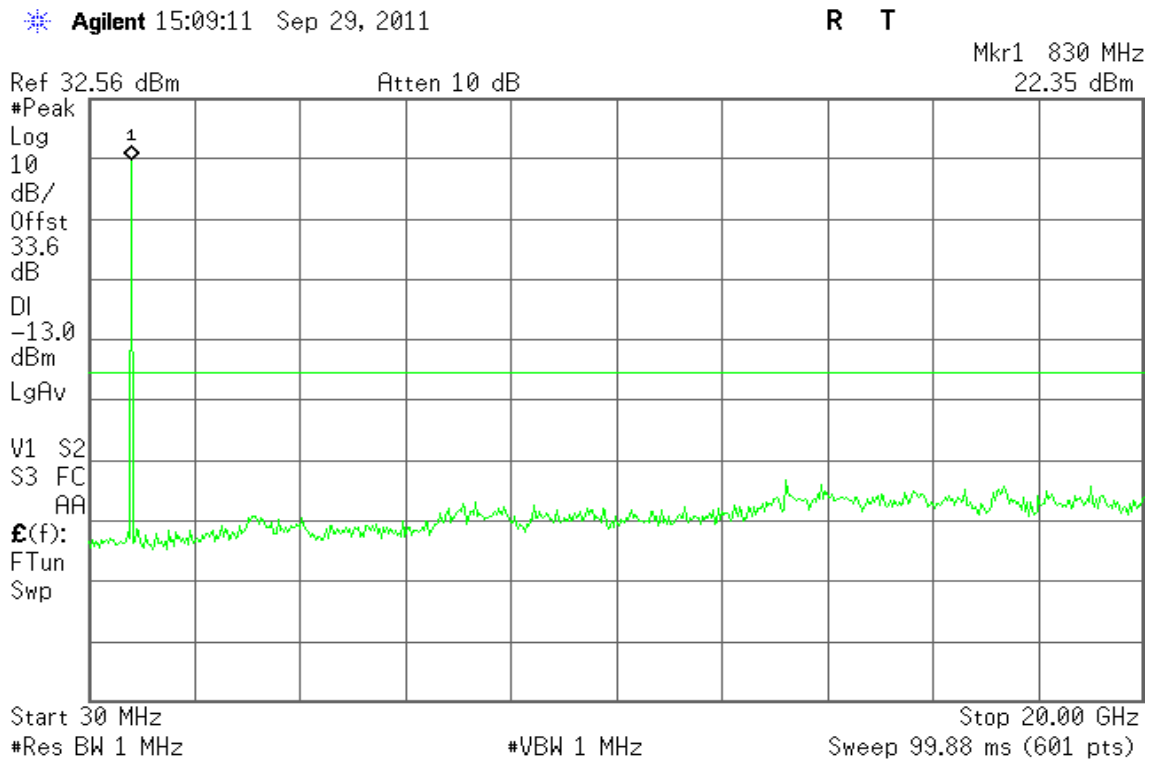



Figure 8-2: Out of Band emission at antenna terminals – CDMA2000 1xEVDO / CH Mid

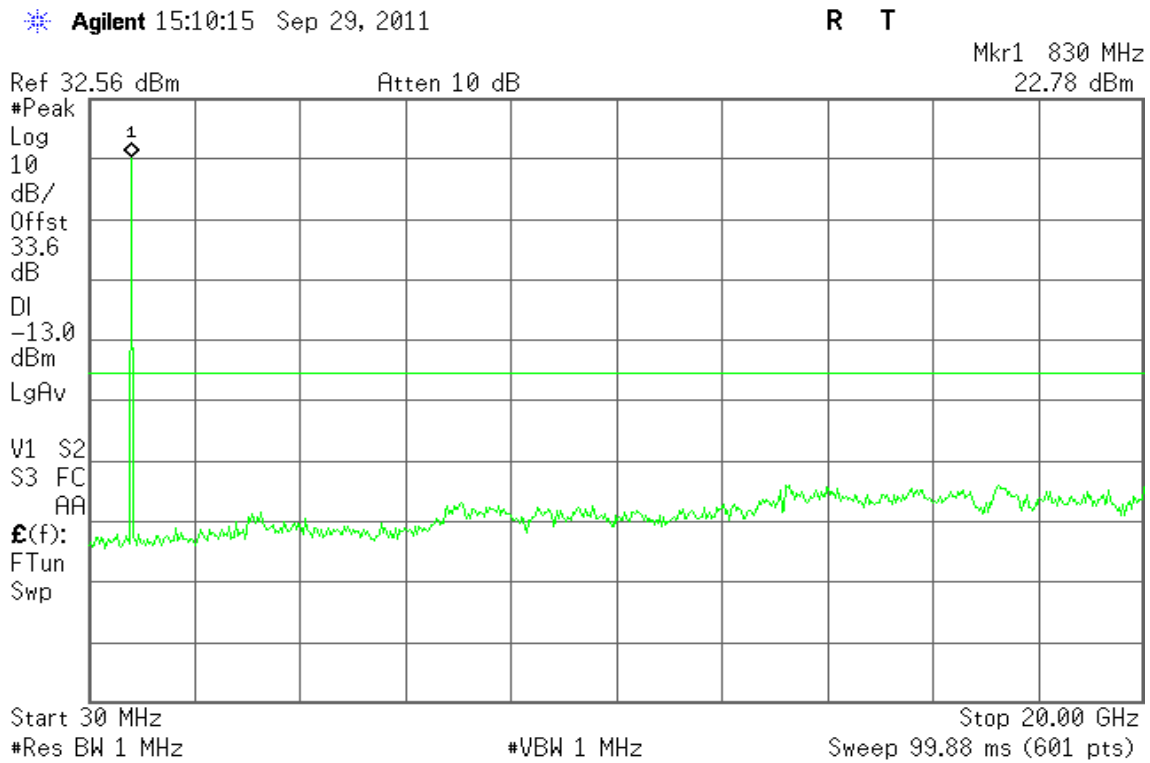
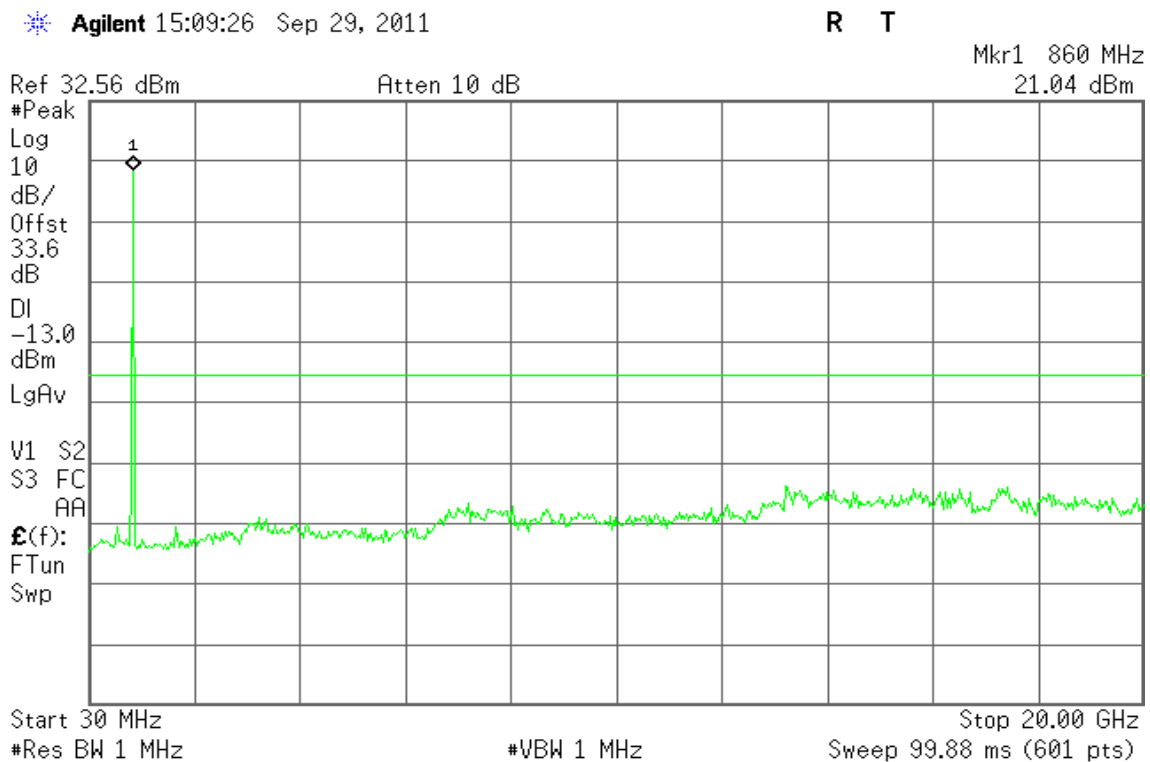

Figure 8-3: Out of Band emission at antenna terminals – CDMA2000 1xEVDO / CH High





CDMA2000 1xRTT PCS

Figure 9-1: Out of Band emission at antenna terminals – CDMA2000 1xRTT / CH Low

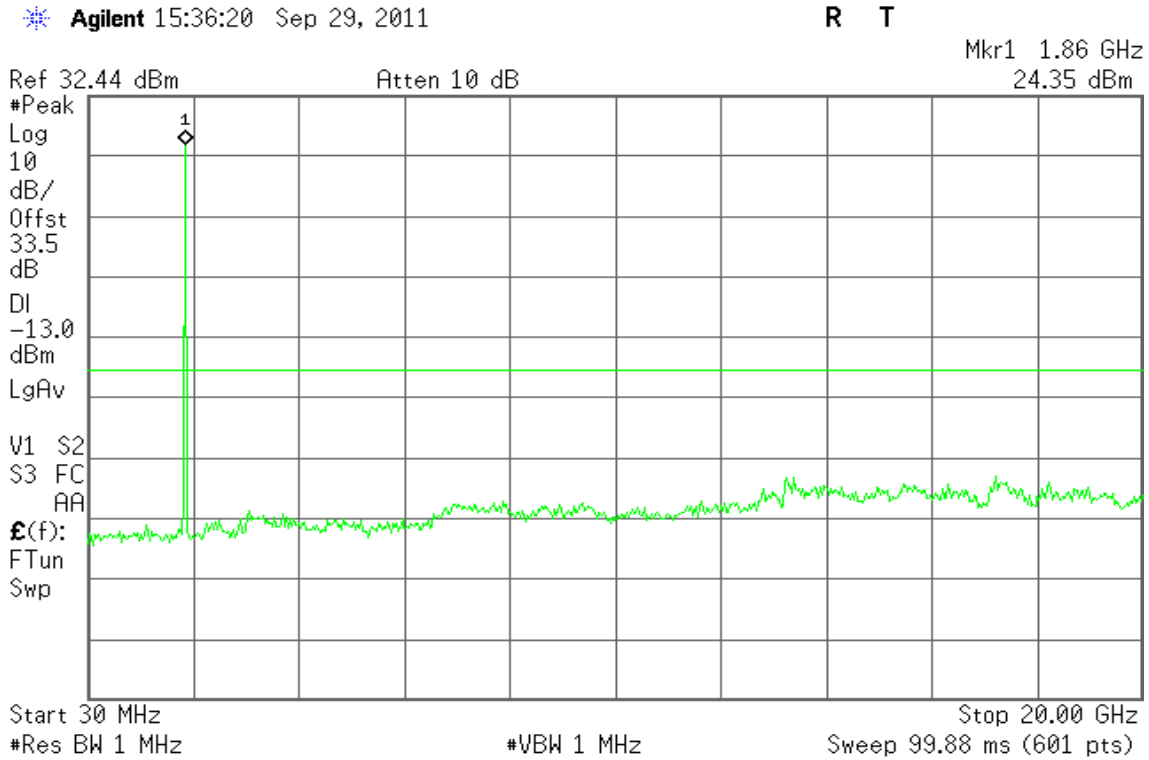

Figure 9-2: Out of Band emission at antenna terminals – CDMA2000 1xRTT / CH Mid

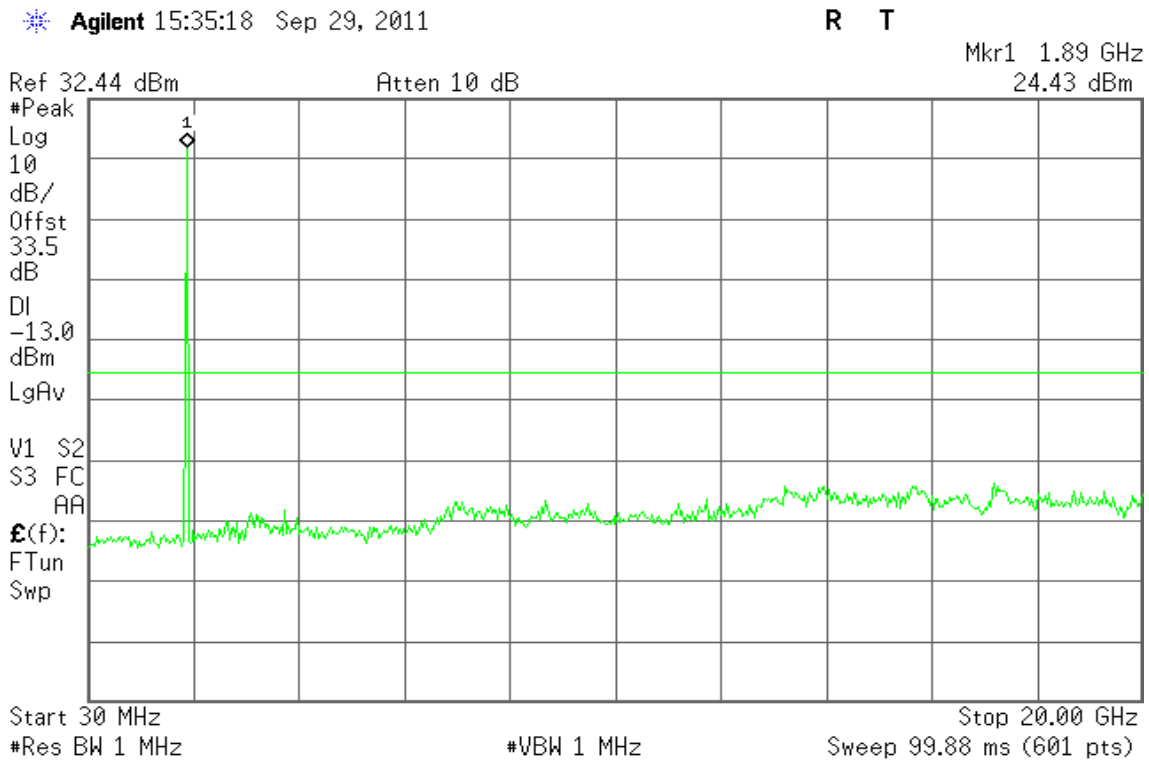
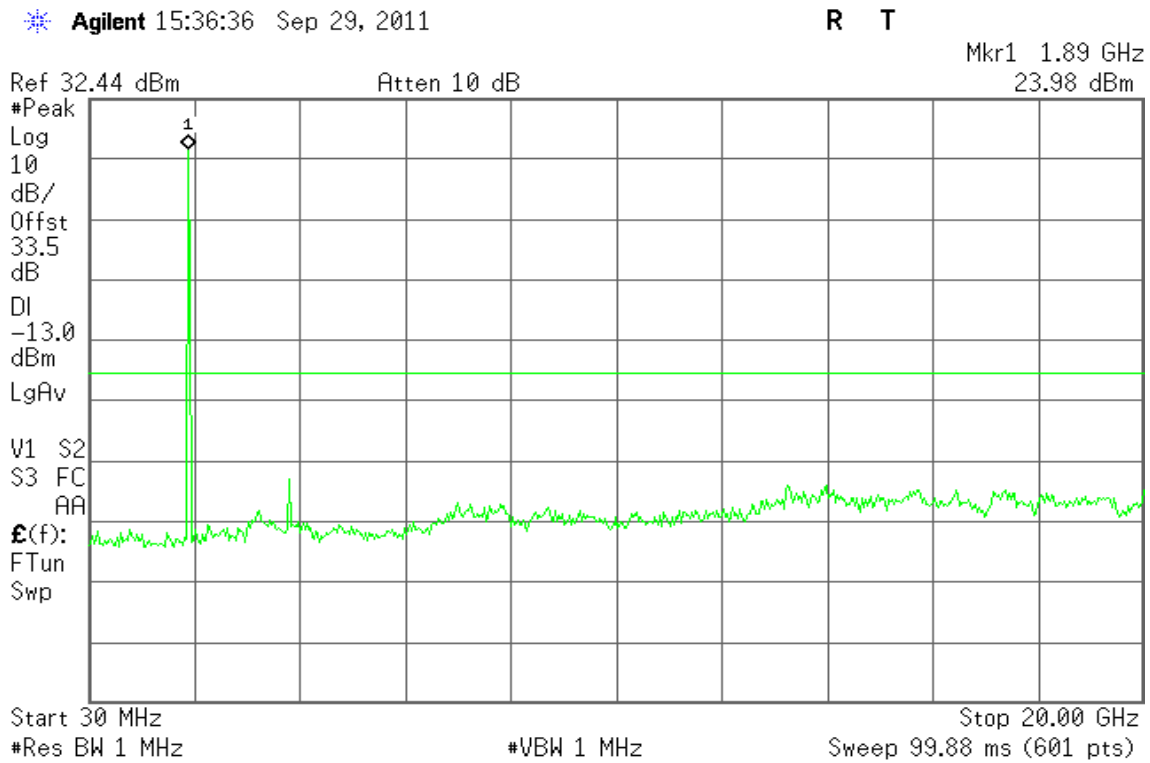



Figure 9-3: Out of Band emission at antenna terminals – CDMA2000 1xRTT / CH High



CDMA2000 1xEVDO PCS

Figure 10-1: Out of Band emission at antenna terminals – CDMA2000 1xEVDO / CH Low

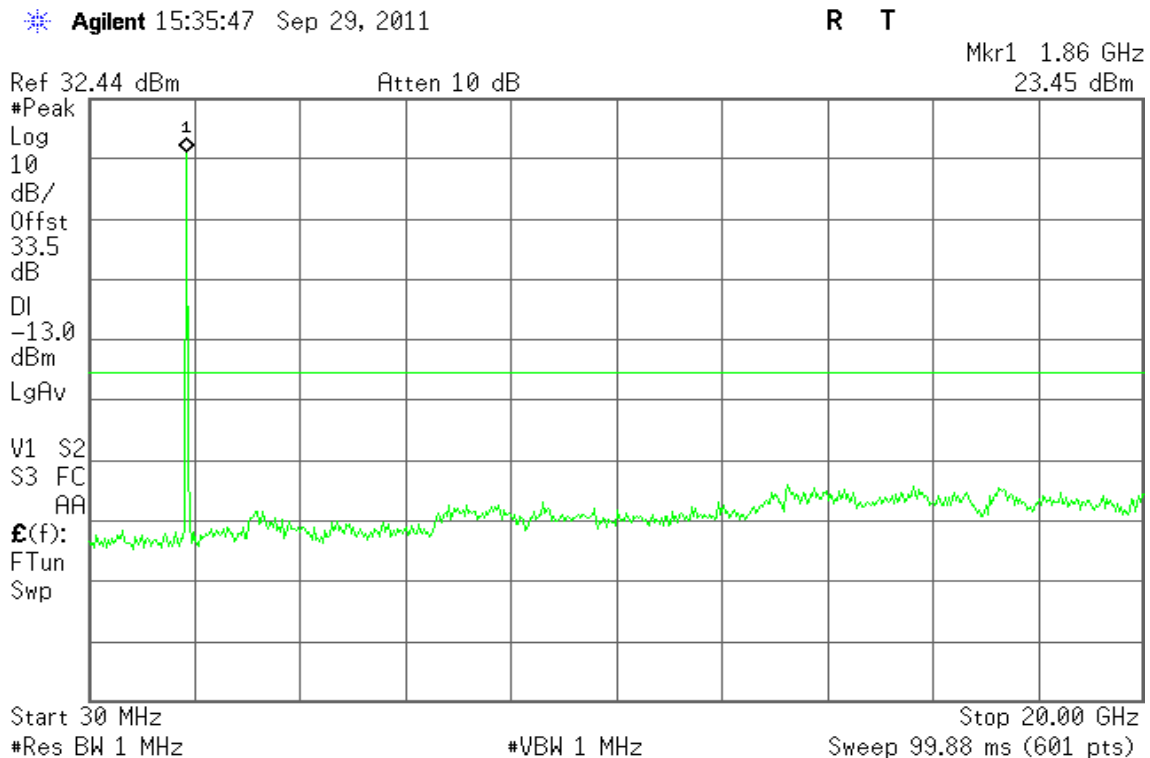



Figure 10-2: Out of Band emission at antenna terminals – CDMA2000 1xEVDO / CH Mid

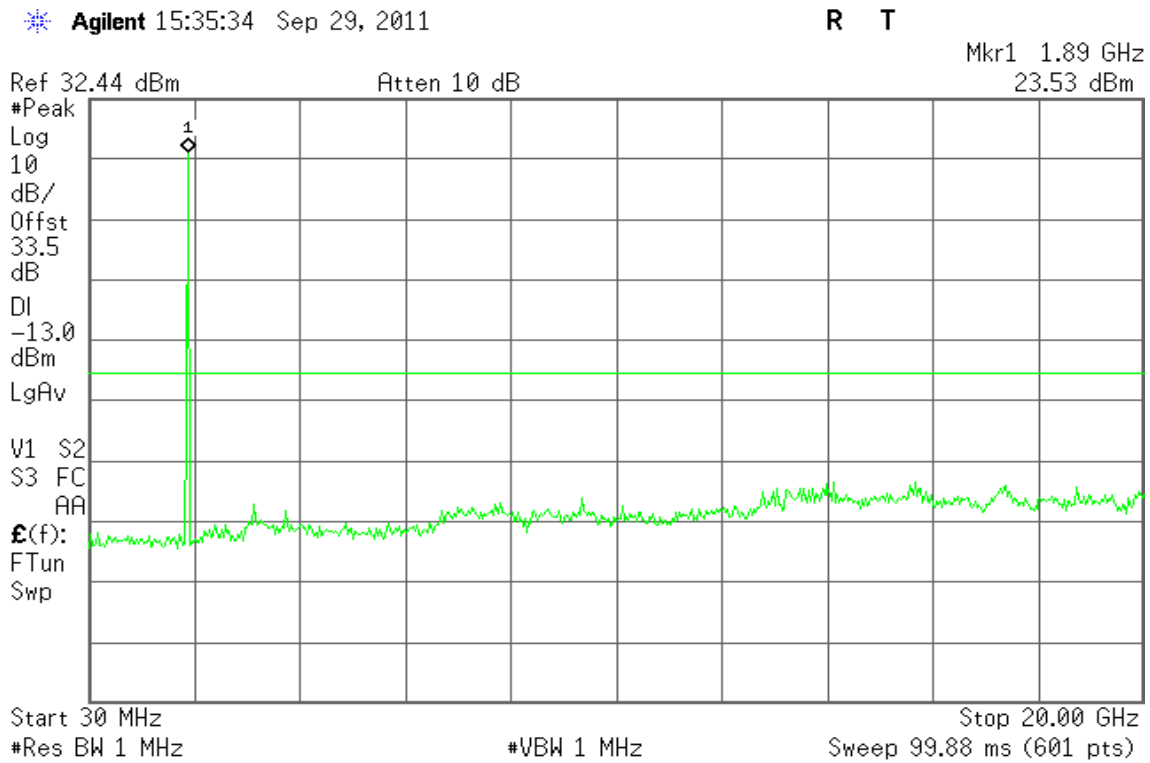
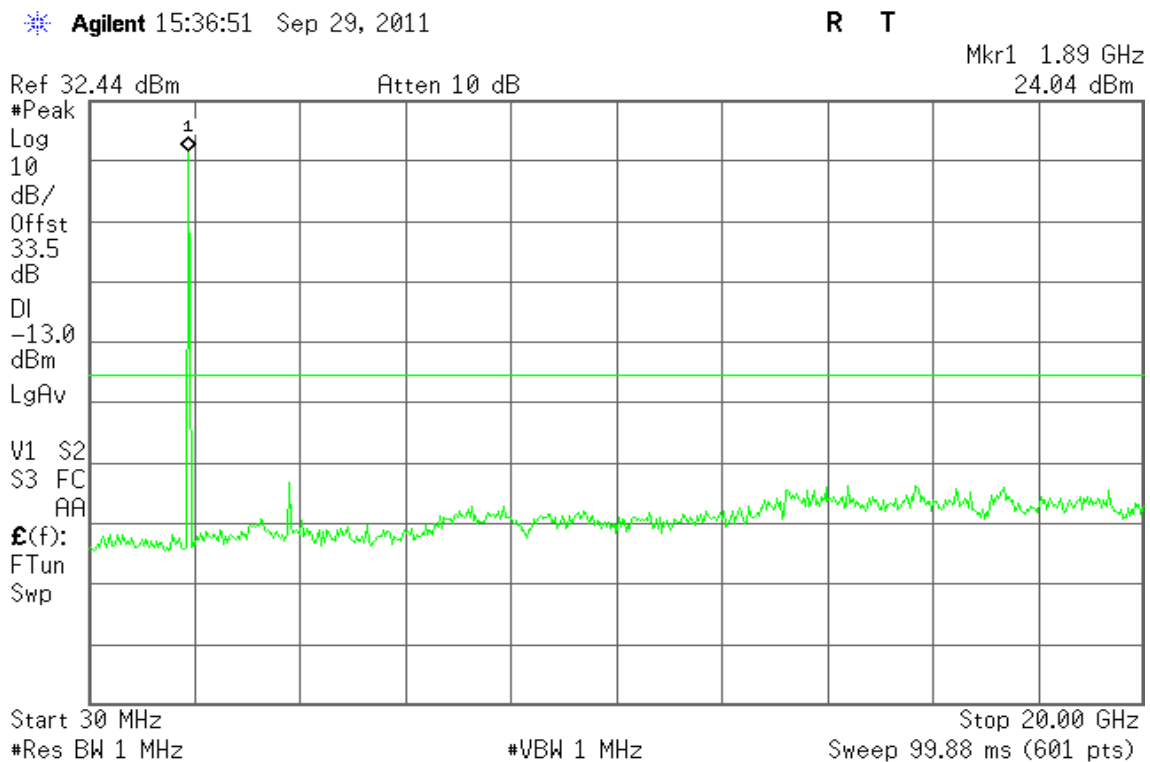

Figure 10-3: Out of Band emission at antenna terminals – CDMA2000 1xEVDO / CH High





CDMA2000 1xRTT Cellular

Figure 11-1: Band Edge emissions – CDMA2000 1xRTT / CH Low

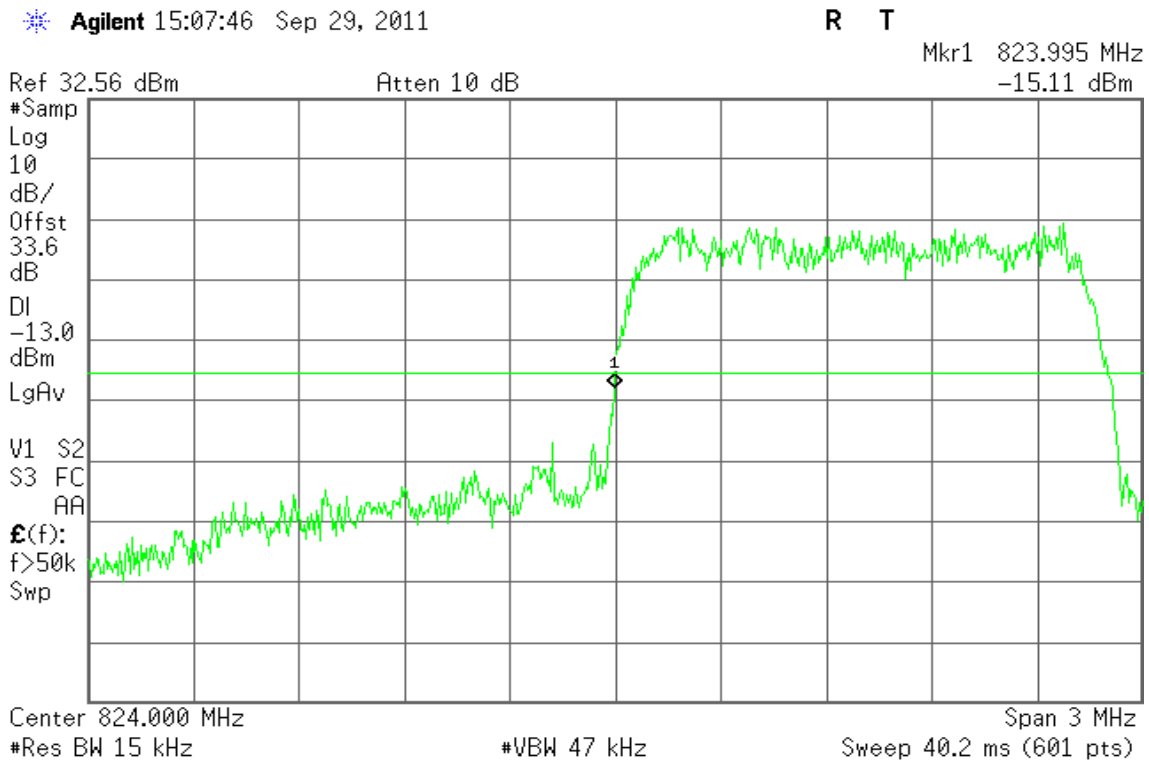
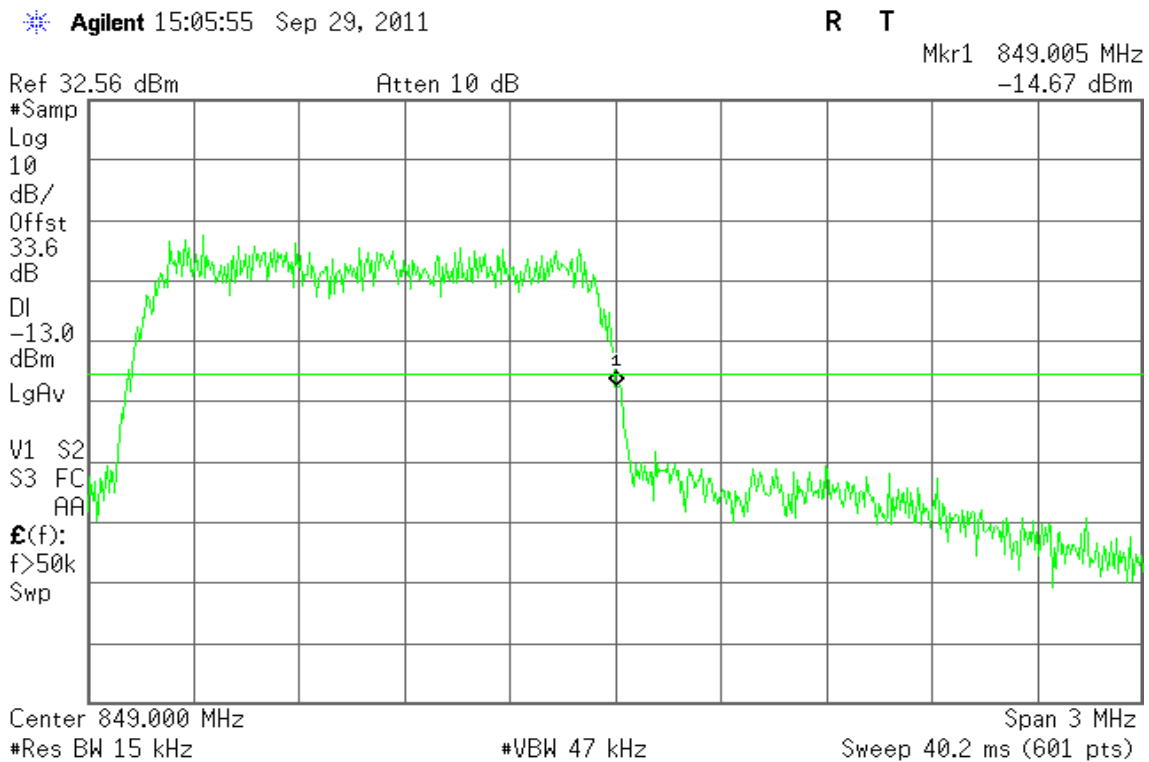

Figure 11-2: Band Edge emissions – CDMA2000 1xRTT / CH High





CDMA2000 1xEVDO Cellular

Figure 12-1: Band Edge emissions – CDMA2000 1xEVDO / CH Low

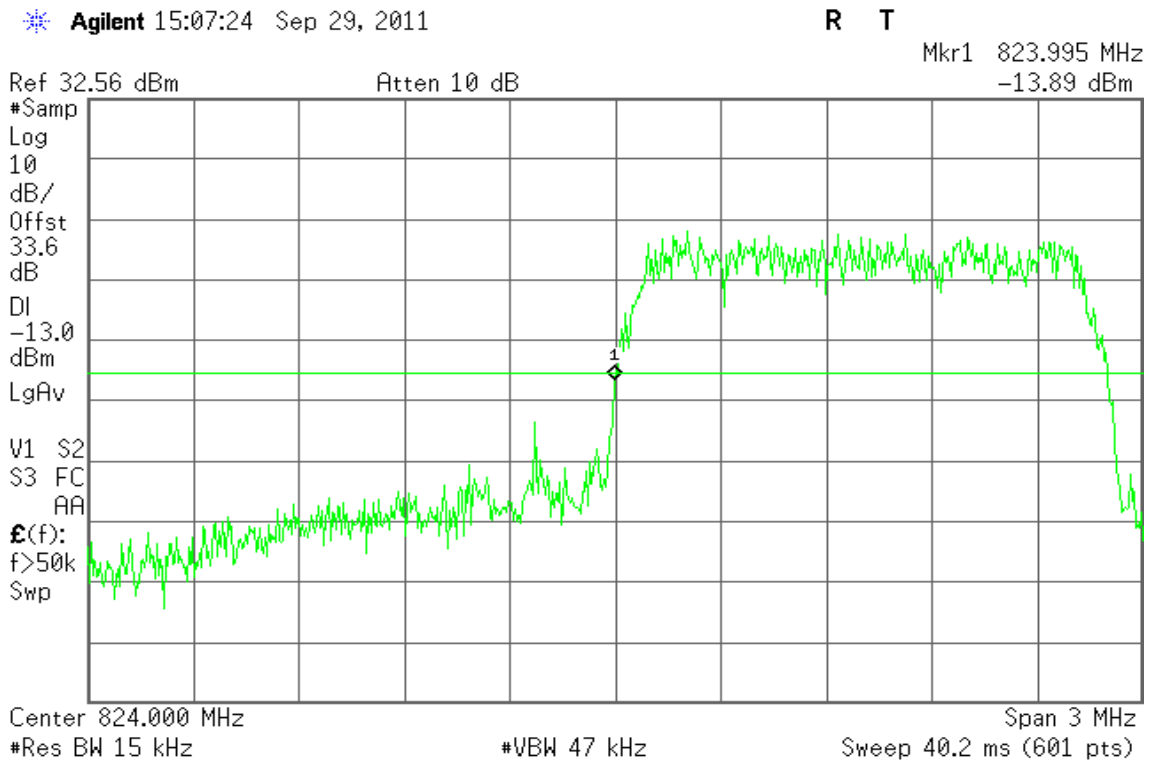
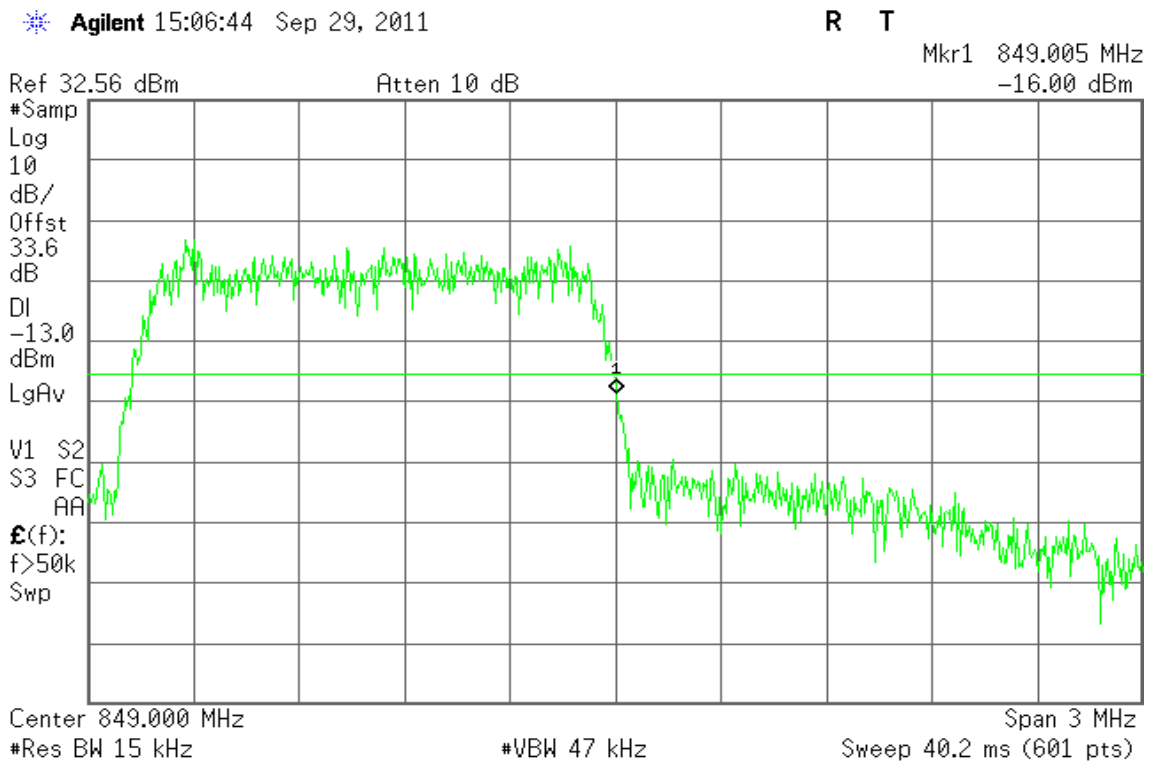

Figure 12-2: Band Edge emissions – CDMA2000 1xEVDO / CH High





CDMA2000 1xRTT PCS

Figure 13-1: Band Edge emissions – CDMA2000 1xRTT / CH Low

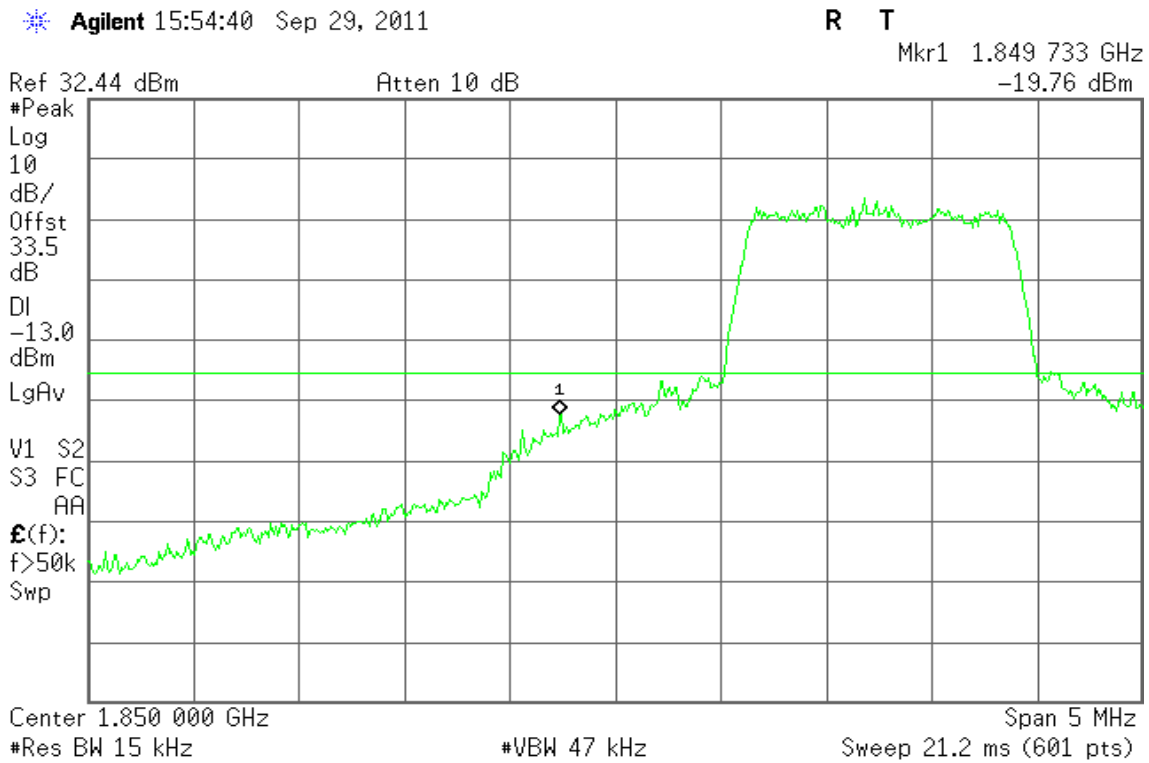
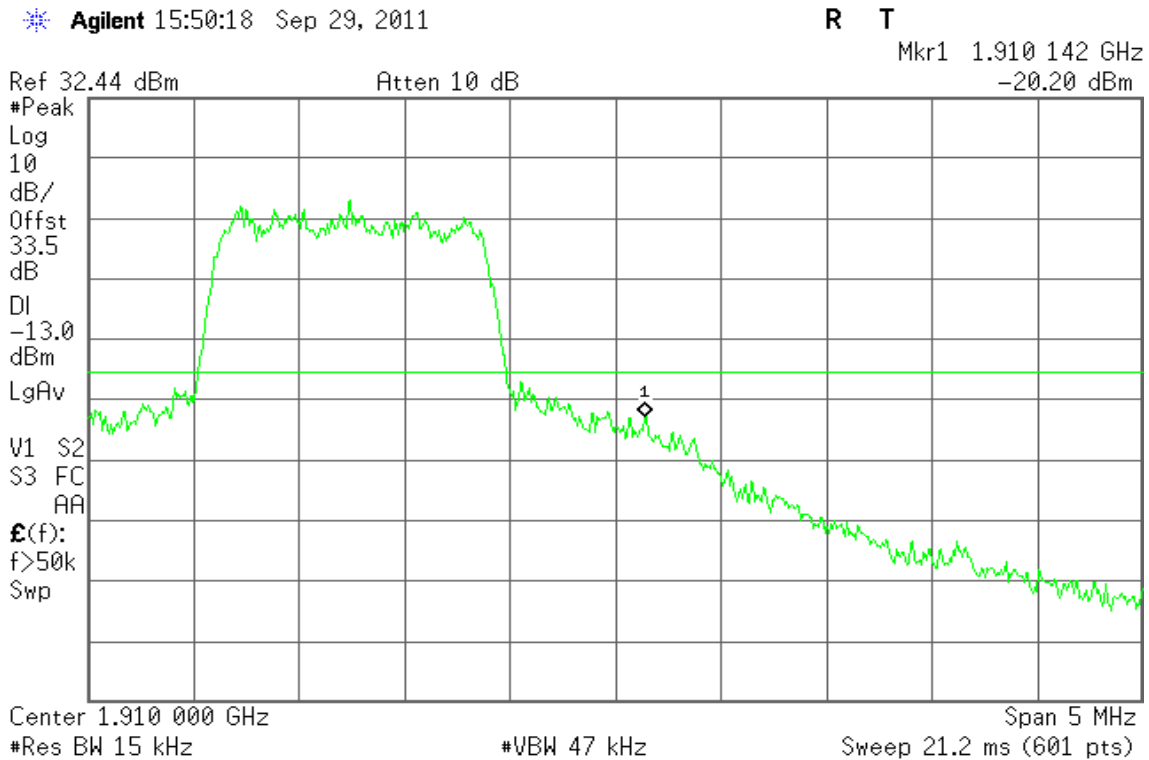

Figure 13-2: Band Edge emissions – CDMA2000 1xRTT / CH High





CDMA2000 1xEVDO PCS

Figure 14-1: Band Edge emissions – CDMA2000 1xEVDO / CH Low

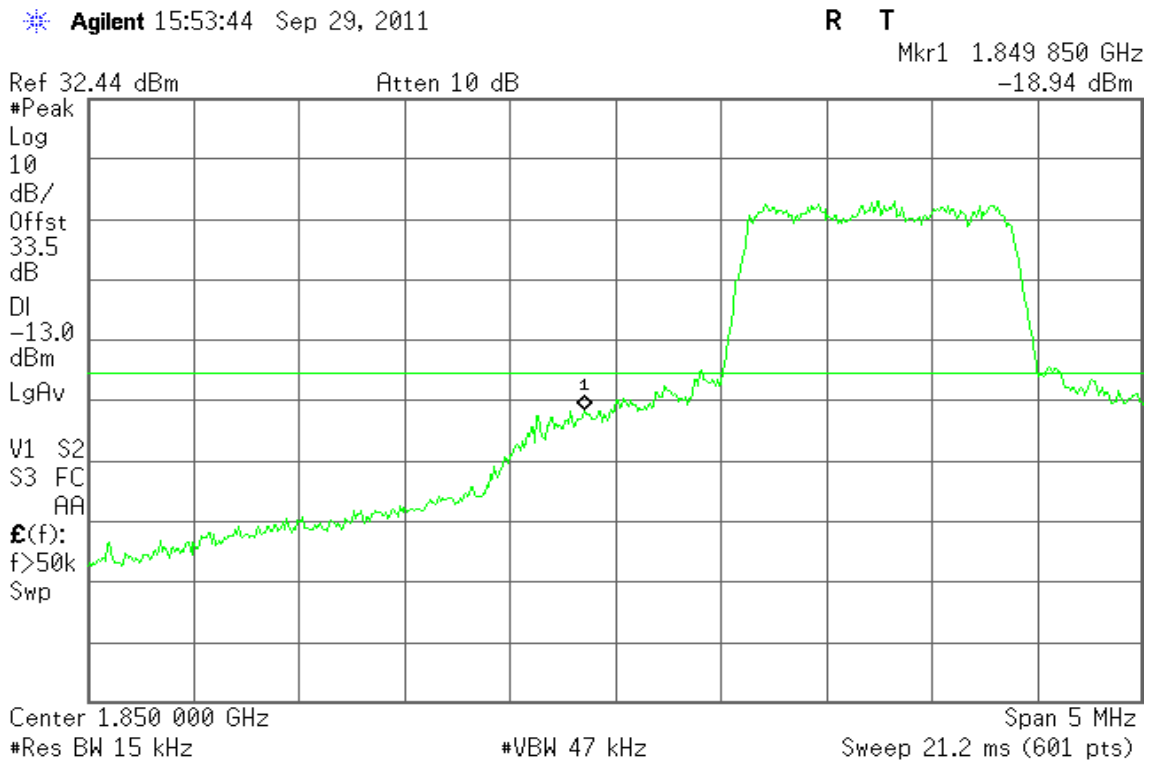
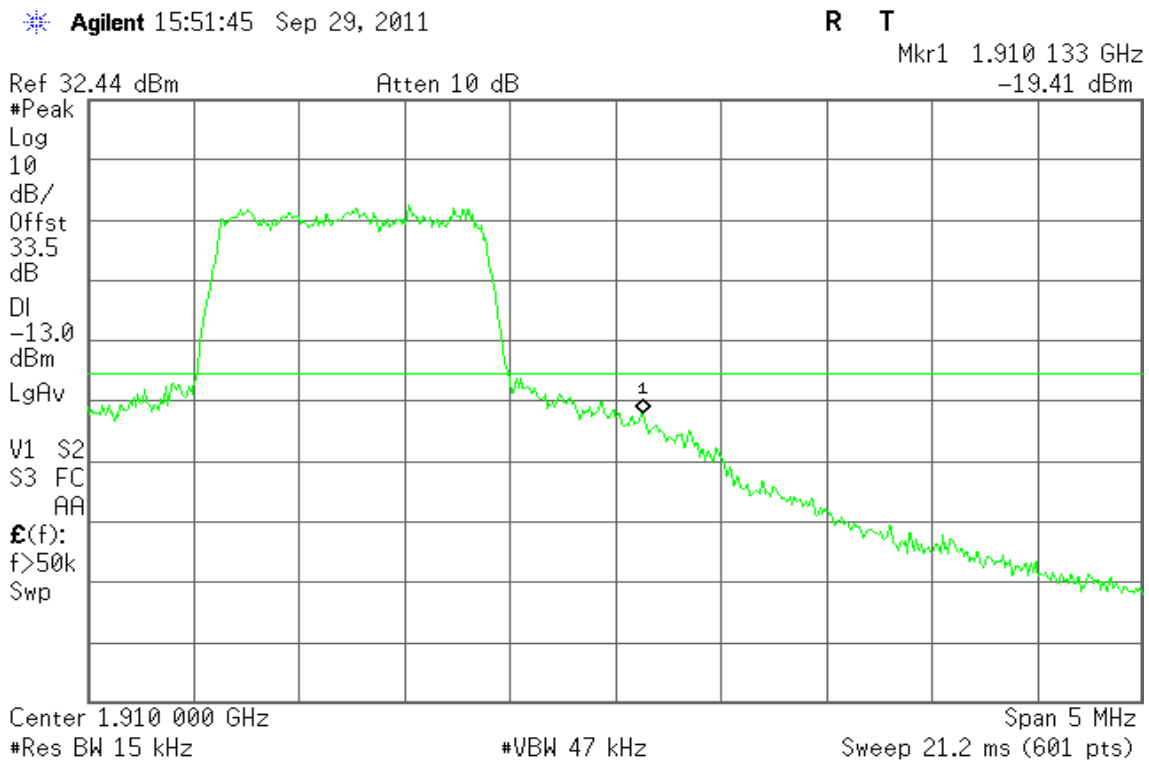

Figure 14-2: Band Edge emissions – CDMA2000 1xEVDO / CH High





7.5 FIELD STRENGTH OF SPURIOUS RADIATION MEASUREMENT

LIMIT

According to FCC §2.1053

Test Configuration

Below 1 GHz

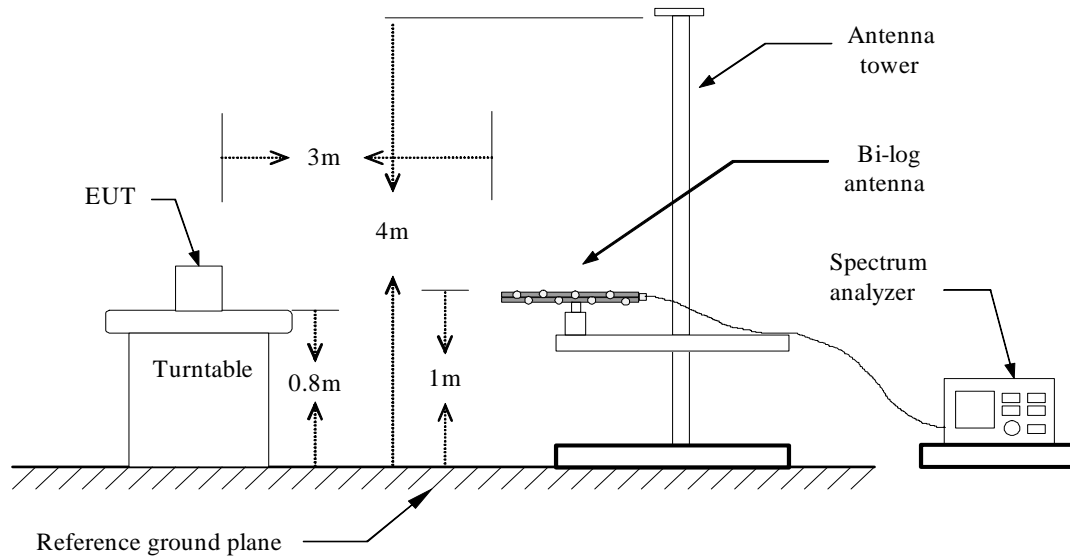

Above 1 GHz

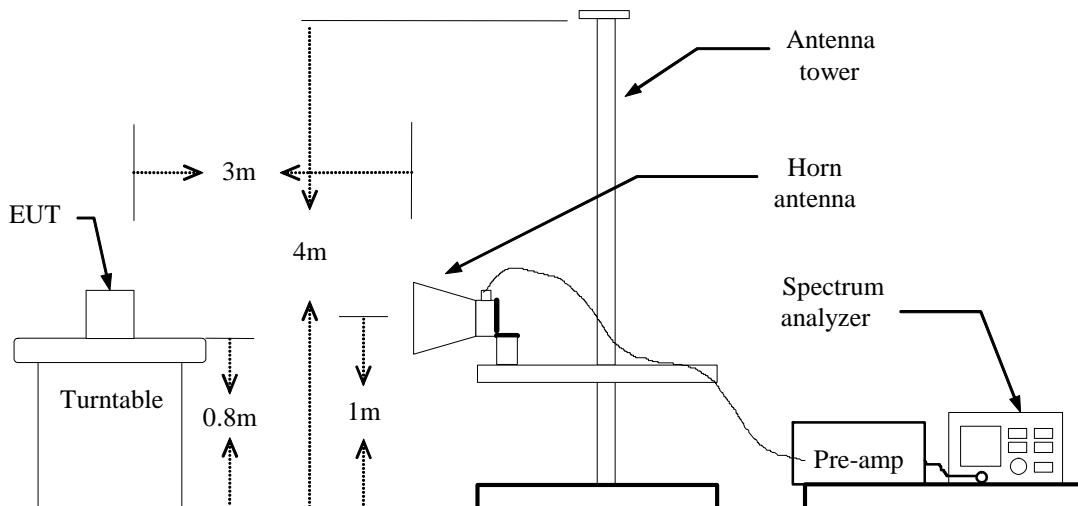



Substituted Method Test Set-up

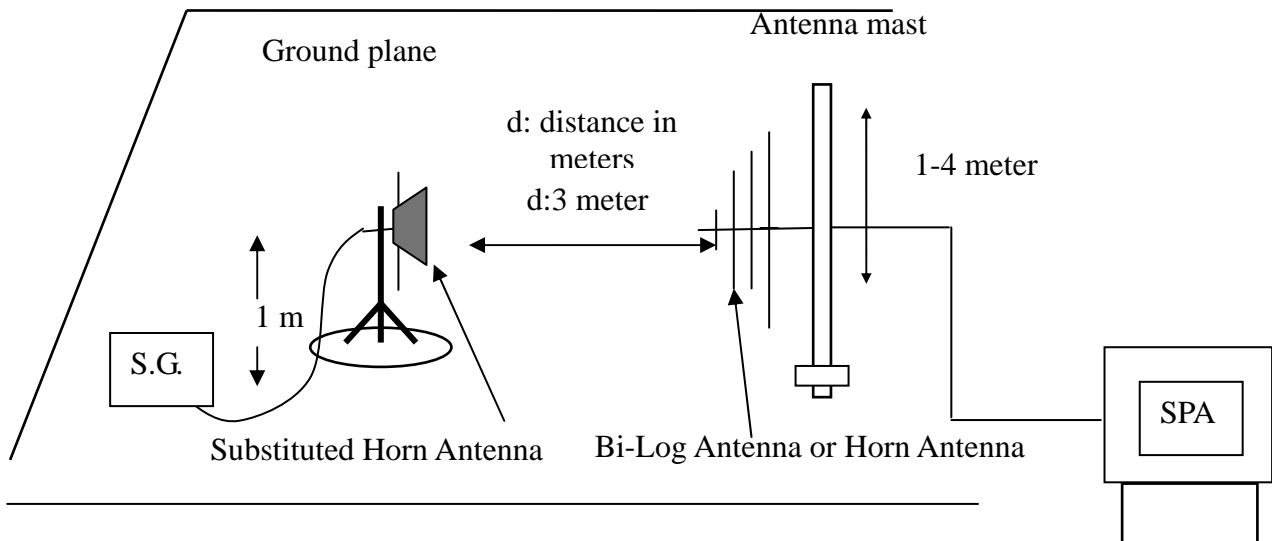

TEST PROCEDURE

The EUT was placed on a non-conductive, the measurement antenna was placed at a distance of 3 meters from the EUT. During the tests, the antenna height and the EUT azimuth were varied in order to identify the maximum level of emissions from the EUT. This maximization process was repeated with the EUT positioned in each of its three orthogonal orientations.

The frequency range up to tenth harmonic was investigated for each of three fundamental frequency (low, middle and high channels). Once spurious emission were identified, the power of the emission was determined using the substitution method.

The spurious emissions attenuation was calculated as the difference between radiated power at the fundamental frequency and the spurious emissions frequency.

$$\text{ERP} = \text{S.G. output (dBm)} + \text{Antenna Gain (dBd)} - \text{Cable (dB)}$$

$$\text{EIRP} = \text{S.G. output (dBm)} + \text{Antenna Gain (dBi)} - \text{Cable (dB)}$$

TEST RESULTS

Refer to the attached tabular data sheets.



Radiated Spurious Emission Measurement Result

Below 1GHz

Operation Mode: CDMA2000 / 850 / TX / CH 384

Test Date: September 28, 2011

Temperature: 25°C

Tested by: Edward Lin

Humidity: 50 % RH

Polarity: Ver. / Hor.

Frequency (MHz)	S.G. (dBm)	Cable loss (dB)	Ant.Gain (dBi)	Emission level (dBm)	Limit (dBm)	Margin (dB)	Antenna Polarization (V/H)
207.0250	-80.94	1.67	4.82	-77.79	-13.00	-64.79	V
265.2250	-79.75	1.95	5.34	-76.36	-13.00	-63.36	V
323.4250	-75.76	2.18	5.7	-72.24	-13.00	-59.24	V
384.0500	-76.97	2.31	5.99	-73.29	-13.00	-60.29	V
442.2500	-78.23	2.55	5.85	-74.93	-13.00	-61.93	V
531.9750	-76.59	2.76	6.07	-73.28	-13.00	-60.28	V
207.0250	-74.45	1.67	4.82	-71.30	-13.00	-58.30	H
265.2250	-73.16	1.95	5.34	-69.77	-13.00	-56.77	H
384.0500	-71.11	2.31	5.99	-67.43	-13.00	-54.43	H
442.2500	-72.14	2.55	5.85	-68.84	-13.00	-55.84	H
531.9750	-73.22	2.76	6.07	-69.91	-13.00	-56.91	H
619.2750	-75.02	2.94	6.11	-71.85	-13.00	-58.85	H

Remark:

1. *Measuring frequencies from 1 GHz to the 10th harmonic of highest fundamental frequency.*
2. *Measurements above show only up to 6 maximum emissions noted, or would be lesser, with " N/A " remark, if no specific emissions from the EUT are recorded (ie: margin>20dB from the applicable limit) and considered that's already beyond the background noise floor.*



Operation Mode: CDMA2000 / 850 / TX / CH 777

Test Date: September 28, 2011

Temperature: 25°C

Tested by: Edward Lin

Humidity: 50 % RH

Polarity: Ver. / Hor.

Frequency (MHz)	S.G. (dBm)	Cable loss (dB)	Ant.Gain (dBi)	Emission level (dBm)	Limit (dBm)	Margin (dB)	Antenna Polarization (V/H)
119.7250	-75.3	1.27	-2.09	-78.66	-13.00	-65.66	V
207.0250	-80.15	1.67	4.82	-77.00	-13.00	-64.00	V
265.2250	-80.22	1.95	5.34	-76.83	-13.00	-63.83	V
325.8500	-76.58	2.17	5.71	-73.04	-13.00	-60.04	V
384.0500	-75.97	2.31	5.99	-72.29	-13.00	-59.29	V
531.9750	-76.08	2.76	6.07	-72.77	-13.00	-59.77	V
119.7250	-67.26	1.27	-2.09	-70.62	-13.00	-57.62	H
207.0250	-73.18	1.67	4.82	-70.03	-13.00	-57.03	H
265.2250	-69.95	1.95	5.34	-66.56	-13.00	-53.56	H
384.0500	-70.69	2.31	5.99	-67.01	-13.00	-54.01	H
531.9750	-72.63	2.76	6.07	-69.32	-13.00	-56.32	H
619.2750	-75.06	2.94	6.11	-71.89	-13.00	-58.89	H

Remark:

- 1. Measuring frequencies from 1 GHz to the 10th harmonic of highest fundamental frequency.*
- 2. Measurements above show only up to 6 maximum emissions noted, or would be lesser, with " N/A " remark, if no specific emissions from the EUT are recorded (ie: margin>20dB from the applicable limit) and considered that's already beyond the background noise floor.*



Operation Mode: CDMA2000 / 850 / TX / CH 1013

Test Date: September 28, 2011

Temperature: 25°C

Tested by: Edward Lin

Humidity: 50 % RH

Polarity: Ver. / Hor.

Frequency (MHz)	S.G. (dBm)	Cable loss (dB)	Ant.Gain (dBi)	Emission level (dBm)	Limit (dBm)	Margin (dB)	Antenna Polarization (V/H)
148.8250	-77.6	1.42	0.58	-78.44	-13.00	-65.44	V
207.0250	-80.48	1.67	4.82	-77.33	-13.00	-64.33	V
265.2250	-79.14	1.95	5.34	-75.75	-13.00	-62.75	V
325.8500	-75.63	2.17	5.71	-72.09	-13.00	-59.09	V
384.0500	-76.65	2.31	5.99	-72.97	-13.00	-59.97	V
534.4000	-74.35	2.76	6.13	-70.98	-13.00	-57.98	V
207.0250	-73.4	1.67	4.82	-70.25	-13.00	-57.25	H
265.2250	-71.95	1.95	5.34	-68.56	-13.00	-55.56	H
384.0500	-69.42	2.31	5.99	-65.74	-13.00	-52.74	H
442.2500	-70.34	2.55	5.85	-67.04	-13.00	-54.04	H
531.9750	-71.11	2.76	6.07	-67.80	-13.00	-54.80	H
619.2750	-74.79	2.94	6.11	-71.62	-13.00	-58.62	H

Remark:

- 1. Measuring frequencies from 1 GHz to the 10th harmonic of highest fundamental frequency.*
- 2. Measurements above show only up to 6 maximum emissions noted, or would be lesser, with " N/A " remark, if no specific emissions from the EUT are recorded (ie: margin>20dB from the applicable limit) and considered that's already beyond the background noise floor.*



Operation Mode: CDMA2000 / 1900 / TX / CH 25

Test Date: September 28, 2011

Temperature: 25°C

Tested by: Edward Lin

Humidity: 50 % RH

Polarity: Ver. / Hor.

Frequency (MHz)	S.G. (dBm)	Cable loss (dB)	Ant.Gain (dBi)	Emission level (dBm)	Limit (dBm)	Margin (dB)	Antenna Polarization (V/H)
187.6250	-76.94	1.62	3.9	-74.66	-13.00	-61.66	V
325.8500	-75.09	2.17	5.71	-71.55	-13.00	-58.55	V
384.0500	-76.68	2.31	5.99	-73.00	-13.00	-60.00	V
531.9750	-75.1	2.76	6.07	-71.79	-13.00	-58.79	V
558.6500	-76.63	2.84	6.04	-73.43	-13.00	-60.43	V
796.3000	-65.87	3.33	6.41	-62.79	-13.00	-49.79	V
207.0250	-73.45	1.67	4.82	-70.30	-13.00	-57.30	H
265.2250	-71.9	1.95	5.34	-68.51	-13.00	-55.51	H
384.0500	-70.23	2.31	5.99	-66.55	-13.00	-53.55	H
442.2500	-70.72	2.55	5.85	-67.42	-13.00	-54.42	H
531.9750	-72.62	2.76	6.07	-69.31	-13.00	-56.31	H
798.7250	-63.65	3.33	6.48	-60.50	-13.00	-47.50	H

Remark:

1. *Measuring frequencies from 1 GHz to the 10th harmonic of highest fundamental frequency.*
2. *Measurements above show only up to 6 maximum emissions noted, or would be lesser, with " N/A " remark, if no specific emissions from the EUT are recorded (ie: margin>20dB from the applicable limit) and considered that's already beyond the background noise floor.*



Operation Mode: CDMA2000 / 1900 / TX / CH 600

Test Date: September 28, 2011

Temperature: 25°C

Tested by: Edward Lin

Humidity: 50 % RH

Polarity: Ver. / Hor.

Frequency (MHz)	S.G. (dBm)	Cable loss (dB)	Ant.Gain (dBi)	Emission level (dBm)	Limit (dBm)	Margin (dB)	Antenna Polarization (V/H)
207.0250	-80.95	1.67	4.82	-77.80	-13.00	-64.80	V
265.2250	-79.85	1.95	5.34	-76.46	-13.00	-63.46	V
325.8500	-76.15	2.17	5.71	-72.61	-13.00	-59.61	V
384.0500	-77.18	2.31	5.99	-73.50	-13.00	-60.50	V
531.9750	-76.11	2.76	6.07	-72.80	-13.00	-59.80	V
798.7250	-67.13	3.33	6.48	-63.98	-13.00	-50.98	V
119.7250	-65.77	1.27	-2.09	-69.13	-13.00	-56.13	H
384.0500	-71.02	2.31	5.99	-67.34	-13.00	-54.34	H
442.2500	-70.9	2.55	5.85	-67.60	-13.00	-54.60	H
534.4000	-73.18	2.76	6.13	-69.81	-13.00	-56.81	H
619.2750	-75.2	2.94	6.11	-72.03	-13.00	-59.03	H
798.7250	-67.3	3.33	6.48	-64.15	-13.00	-51.15	H

Remark:

1. *Measuring frequencies from 1 GHz to the 10th harmonic of highest fundamental frequency.*
2. *Measurements above show only up to 6 maximum emissions noted, or would be lesser, with " N/A " remark, if no specific emissions from the EUT are recorded (ie: margin > 20dB from the applicable limit) and considered that's already beyond the background noise floor.*



Operation Mode: CDMA2000 / 1900 / TX / CH 1175

Test Date: September 28, 2011

Temperature: 25°C

Tested by: Edward Lin

Humidity: 50 % RH

Polarity: Ver. / Hor.

Frequency (MHz)	S.G. (dBm)	Cable loss (dB)	Ant.Gain (dBi)	Emission level (dBm)	Limit (dBm)	Margin (dB)	Antenna Polarization (V/H)
207.0250	-80.71	1.67	4.82	-77.56	-13.00	-64.56	V
325.8500	-75.66	2.17	5.71	-72.12	-13.00	-59.12	V
384.0500	-77.96	2.31	5.99	-74.28	-13.00	-61.28	V
531.9750	-75.88	2.76	6.07	-72.57	-13.00	-59.57	V
558.6500	-76.61	2.84	6.04	-73.41	-13.00	-60.41	V
801.1500	-68.17	3.33	6.55	-64.95	-13.00	-51.95	V
119.7250	-67.47	1.27	-2.09	-70.83	-13.00	-57.83	H
265.2250	-72.6	1.95	5.34	-69.21	-13.00	-56.21	H
384.0500	-70.92	2.31	5.99	-67.24	-13.00	-54.24	H
442.2500	-71.97	2.55	5.85	-68.67	-13.00	-55.67	H
534.4000	-73.19	2.76	6.13	-69.82	-13.00	-56.82	H
801.1500	-66.37	3.33	6.55	-63.15	-13.00	-50.15	H

Remark:

1. *Measuring frequencies from 1 GHz to the 10th harmonic of highest fundamental frequency.*
2. *Measurements above show only up to 6 maximum emissions noted, or would be lesser, with " N/A " remark, if no specific emissions from the EUT are recorded (ie: margin > 20dB from the applicable limit) and considered that's already beyond the background noise floor.*



Operation Mode: EVDO / 850 / TX / CH 384

Test Date: September 28, 2011

Temperature: 25°C

Tested by: Edward Lin

Humidity: 50 % RH

Polarity: Ver. / Hor.

Frequency (MHz)	S.G. (dBm)	Cable loss (dB)	Ant.Gain (dBi)	Emission level (dBm)	Limit (dBm)	Margin (dB)	Antenna Polarization (V/H)
148.8250	-74.18	1.42	0.58	-75.02	-13.00	-62.02	V
207.0250	-79.42	1.67	4.82	-76.27	-13.00	-63.27	V
279.7750	-79.88	2	5.3	-76.58	-13.00	-63.58	V
384.0500	-80.81	2.31	5.99	-77.13	-13.00	-64.13	V
442.2500	-78.99	2.55	5.85	-75.69	-13.00	-62.69	V
531.9750	-76.86	2.76	6.07	-73.55	-13.00	-60.55	V
105.1750	-63.52	1.18	-1.07	-65.77	-13.00	-52.77	H
221.5750	-75.63	1.77	5.34	-72.06	-13.00	-59.06	H
279.7750	-75.43	2	5.3	-72.13	-13.00	-59.13	H
442.2500	-73.23	2.55	5.85	-69.93	-13.00	-56.93	H
466.5000	-71.89	2.61	5.82	-68.68	-13.00	-55.68	H
531.9750	-74.06	2.76	6.07	-70.75	-13.00	-57.75	H

Remark:

1. *Measuring frequencies from 1 GHz to the 10th harmonic of highest fundamental frequency.*
2. *Measurements above show only up to 6 maximum emissions noted, or would be lesser, with " N/A " remark, if no specific emissions from the EUT are recorded (ie: margin > 20dB from the applicable limit) and considered that's already beyond the background noise floor.*



Operation Mode: EVDO / 850 / TX / CH 777

Test Date: September 28, 2011

Temperature: 25°C

Tested by: Edward Lin

Humidity: 50 % RH

Polarity: Ver. / Hor.

Frequency (MHz)	S.G. (dBm)	Cable loss (dB)	Ant.Gain (dBi)	Emission level (dBm)	Limit (dBm)	Margin (dB)	Antenna Polarization (V/H)
148.8250	-74.46	1.42	0.58	-75.30	-13.00	-62.30	V
250.6750	-78.74	1.84	5.7	-74.88	-13.00	-61.88	V
282.2000	-78.85	2.01	5.33	-75.53	-13.00	-62.53	V
384.0500	-81.14	2.31	5.99	-77.46	-13.00	-64.46	V
442.2500	-80.26	2.55	5.85	-76.96	-13.00	-63.96	V
531.9750	-76.83	2.76	6.07	-73.52	-13.00	-60.52	V
102.7500	-66.22	1.16	-0.76	-68.14	-13.00	-55.14	H
221.5750	-75.91	1.77	5.34	-72.34	-13.00	-59.34	H
250.6750	-76.43	1.84	5.7	-72.57	-13.00	-59.57	H
384.0500	-76.45	2.31	5.99	-72.77	-13.00	-59.77	H
442.2500	-74.29	2.55	5.85	-70.99	-13.00	-57.99	H
531.9750	-76.12	2.76	6.07	-72.81	-13.00	-59.81	H

Remark:

- 1. Measuring frequencies from 1 GHz to the 10th harmonic of highest fundamental frequency.*
- 2. Measurements above show only up to 6 maximum emissions noted, or would be lesser, with " N/A " remark, if no specific emissions from the EUT are recorded (ie: margin > 20dB from the applicable limit) and considered that's already beyond the background noise floor.*



Operation Mode: EVDO / 850 / TX / CH 1013

Test Date: September 28, 2011

Temperature: 25°C

Tested by: Edward Lin

Humidity: 50 % RH

Polarity: Ver. / Hor.

Frequency (MHz)	S.G. (dBm)	Cable loss (dB)	Ant.Gain (dBi)	Emission level (dBm)	Limit (dBm)	Margin (dB)	Antenna Polarization (V/H)
102.7500	-75.39	1.16	-0.76	-77.31	-13.00	-64.31	V
163.3750	-71.82	1.51	1.77	-71.56	-13.00	-58.56	V
279.7750	-75.02	2	5.3	-71.72	-13.00	-58.72	V
384.0500	-76.8	2.31	5.99	-73.12	-13.00	-60.12	V
442.2500	-75.58	2.55	5.85	-72.28	-13.00	-59.28	V
531.9750	-73.68	2.76	6.07	-70.37	-13.00	-57.37	V
102.7500	-65.23	1.16	-0.76	-67.15	-13.00	-54.15	H
221.5750	-74.04	1.77	5.34	-70.47	-13.00	-57.47	H
250.6750	-73.97	1.84	5.7	-70.11	-13.00	-57.11	H
325.8500	-76.27	2.17	5.71	-72.73	-13.00	-59.73	H
464.0750	-72.47	2.61	5.84	-69.24	-13.00	-56.24	H
531.9750	-74.52	2.76	6.07	-71.21	-13.00	-58.21	H

Remark:

- 1. Measuring frequencies from 1 GHz to the 10th harmonic of highest fundamental frequency.*
- 2. Measurements above show only up to 6 maximum emissions noted, or would be lesser, with " N/A " remark, if no specific emissions from the EUT are recorded (ie: margin > 20dB from the applicable limit) and considered that's already beyond the background noise floor.*



Operation Mode: EVDO / 1900 / TX / CH 25

Test Date: September 28, 2011

Temperature: 25°C

Tested by: Edward Lin

Humidity: 50 % RH

Polarity: Ver. / Hor.

Frequency (MHz)	S.G. (dBm)	Cable loss (dB)	Ant.Gain (dBi)	Emission level (dBm)	Limit (dBm)	Margin (dB)	Antenna Polarization (V/H)
71.2250	-75.15	0.97	-1.7	-77.82	-13.00	-64.82	V
250.6750	-75.34	1.84	5.7	-71.48	-13.00	-58.48	V
308.8750	-77.17	2.13	5.78	-73.52	-13.00	-60.52	V
384.0500	-77.77	2.31	5.99	-74.09	-13.00	-61.09	V
531.9750	-77.41	2.76	6.07	-74.10	-13.00	-61.10	V
798.7250	-62.84	3.33	6.48	-59.69	-13.00	-46.69	V
105.1750	-64.88	1.18	-1.07	-67.13	-13.00	-54.13	H
250.6750	-72.53	1.84	5.7	-68.67	-13.00	-55.67	H
354.9500	-73.32	2.25	5.75	-69.82	-13.00	-56.82	H
384.0500	-70.91	2.31	5.99	-67.23	-13.00	-54.23	H
442.2500	-69.97	2.55	5.85	-66.67	-13.00	-53.67	H
798.7250	-65.71	3.33	6.48	-62.56	-13.00	-49.56	H

Remark:

1. *Measuring frequencies from 1 GHz to the 10th harmonic of highest fundamental frequency.*
2. *Measurements above show only up to 6 maximum emissions noted, or would be lesser, with " N/A " remark, if no specific emissions from the EUT are recorded (ie: margin>20dB from the applicable limit) and considered that's already beyond the background noise floor.*



Operation Mode: EVDO / 1900 / TX / CH 600

Test Date: September 28, 2011

Temperature: 25°C

Tested by: Edward Lin

Humidity: 50 % RH

Polarity: Ver. / Hor.

Frequency (MHz)	S.G. (dBm)	Cable loss (dB)	Ant.Gain (dBi)	Emission level (dBm)	Limit (dBm)	Margin (dB)	Antenna Polarization (V/H)
163.3750	-78.72	1.51	1.77	-78.46	-13.00	-65.46	V
250.6750	-76.69	1.84	5.7	-72.83	-13.00	-59.83	V
308.8750	-76.86	2.13	5.78	-73.21	-13.00	-60.21	V
384.0500	-77.61	2.31	5.99	-73.93	-13.00	-60.93	V
534.4000	-77.96	2.76	6.13	-74.59	-13.00	-61.59	V
801.1500	-66.2	3.33	6.55	-62.98	-13.00	-49.98	V
102.7500	-65.27	1.16	-0.76	-67.19	-13.00	-54.19	H
250.6750	-72.84	1.84	5.7	-68.98	-13.00	-55.98	H
354.9500	-73.23	2.25	5.75	-69.73	-13.00	-56.73	H
384.0500	-69.97	2.31	5.99	-66.29	-13.00	-53.29	H
442.2500	-69.7	2.55	5.85	-66.40	-13.00	-53.40	H
798.7250	-63.19	3.33	6.48	-60.04	-13.00	-47.04	H

Remark:

1. *Measuring frequencies from 1 GHz to the 10th harmonic of highest fundamental frequency.*
2. *Measurements above show only up to 6 maximum emissions noted, or would be lesser, with " N/A " remark, if no specific emissions from the EUT are recorded (ie: margin > 20dB from the applicable limit) and considered that's already beyond the background noise floor.*



Operation Mode: EVDO / 1900 / TX / CH 1175

Test Date: September 28, 2011

Temperature: 25°C

Tested by: Edward Lin

Humidity: 50 % RH

Polarity: Ver. / Hor.

Frequency (MHz)	S.G. (dBm)	Cable loss (dB)	Ant.Gain (dBi)	Emission level (dBm)	Limit (dBm)	Margin (dB)	Antenna Polarization (V/H)
207.0250	-81.5	1.67	4.82	-78.35	-13.00	-65.35	V
250.6750	-77.63	1.84	5.7	-73.77	-13.00	-60.77	V
323.4250	-77.82	2.18	5.7	-74.30	-13.00	-61.30	V
384.0500	-78.11	2.31	5.99	-74.43	-13.00	-61.43	V
531.9750	-78.01	2.76	6.07	-74.70	-13.00	-61.70	V
796.3000	-65.11	3.33	6.41	-62.03	-13.00	-49.03	V
102.7500	-63.66	1.16	-0.76	-65.58	-13.00	-52.58	H
250.6750	-72.61	1.84	5.7	-68.75	-13.00	-55.75	H
384.0500	-69.61	2.31	5.99	-65.93	-13.00	-52.93	H
442.2500	-68.86	2.55	5.85	-65.56	-13.00	-52.56	H
561.0750	-73.04	2.85	6	-69.89	-13.00	-56.89	H
798.7250	-63.16	3.33	6.48	-60.01	-13.00	-47.01	H

Remark:

1. *Measuring frequencies from 1 GHz to the 10th harmonic of highest fundamental frequency.*
2. *Measurements above show only up to 6 maximum emissions noted, or would be lesser, with " N/A " remark, if no specific emissions from the EUT are recorded (ie: margin > 20dB from the applicable limit) and considered that's already beyond the background noise floor.*



Above 1GHz

Operation Mode: CDMA2000 / 850 / TX / CH 384

Test Date: September 28, 2011

Temperature: 25°C

Tested by: Edward Lin

Humidity: 50 % RH

Polarity: Ver. / Hor.

Frequency (MHz)	S.G. (dBm)	Cable loss (dB)	Ant.Gain (dBi)	Emission level (dBm)	Limit (dBm)	Margin (dB)	Antenna Polarization (V/H)
1682.500	-33.95	5.09	5.97	-33.07	-13.00	-20.07	V
2522.500	-44.52	6.38	6.16	-44.74	-13.00	-31.74	V
N/A							
1682.500	-32.88	5.09	5.97	-32.00	-13.00	-19.00	H
2522.500	-41.5	6.38	6.16	-41.72	-13.00	-28.72	H
N/A							

Remark:

1. *Measuring frequencies from 1 GHz to the 10th harmonic of highest fundamental frequency.*
2. *Measurements above show only up to 6 maximum emissions noted, or would be lesser, with " N/A " remark, if no specific emissions from the EUT are recorded (ie: margin>20dB from the applicable limit) and considered that's already beyond the background noise floor.*



Operation Mode: CDMA2000 / 850 / TX / CH 777

Test Date: September 28, 2011

Temperature: 25°C

Tested by: Edward Lin

Humidity: 50 % RH

Polarity: Ver. / Hor.

Frequency (MHz)	S.G. (dBm)	Cable loss (dB)	Ant.Gain (dBi)	Emission level (dBm)	Limit (dBm)	Margin (dB)	Antenna Polarization (V/H)
1700.000	-33.75	5.11	5.94	-32.92	-13.00	-19.92	V
2557.500	-45.52	6.43	6.25	-45.70	-13.00	-32.70	V
N/A							
1700.000	-34.68	5.11	5.94	-33.85	-13.00	-20.85	H
2557.500	-40.2	6.43	6.25	-40.38	-13.00	-27.38	H
N/A							

Remark:

1. Measuring frequencies from 1 GHz to the 10th harmonic of highest fundamental frequency.
2. Measurements above show only up to 6 maximum emissions noted, or would be lesser, with " N/A " remark, if no specific emissions from the EUT are recorded (ie: margin > 20dB from the applicable limit) and considered that's already beyond the background noise floor.



Operation Mode: CDMA2000 / 850 / TX / CH 1013

Test Date: September 28, 2011

Temperature: 25°C

Tested by: Edward Lin

Humidity: 50 % RH

Polarity: Ver. / Hor.

Frequency (MHz)	S.G. (dBm)	Cable loss (dB)	Ant.Gain (dBi)	Emission level (dBm)	Limit (dBm)	Margin (dB)	Antenna Polarization (V/H)
1647.500	-31.85	5.04	6.03	-30.86	-13.00	-17.86	V
2487.500	-46.54	6.33	6.08	-46.79	-13.00	-33.79	V
N/A							
1647.500	-30.09	5.04	6.03	-29.10	-13.00	-16.10	H
2487.500	-46.07	6.33	6.08	-46.32	-13.00	-33.32	H
N/A							

Remark:

1. Measuring frequencies from 1 GHz to the 10th harmonic of highest fundamental frequency.
2. Measurements above show only up to 6 maximum emissions noted, or would be lesser, with " N/A " remark, if no specific emissions from the EUT are recorded (ie: margin > 20dB from the applicable limit) and considered that's already beyond the background noise floor.



Operation Mode: CDMA2000 / 1900 / TX / CH 25

Test Date: September 28, 2011

Temperature: 25°C

Tested by: Edward Lin

Humidity: 50 % RH

Polarity: Ver. / Hor.

Frequency (MHz)	S.G. (dBm)	Cable loss (dB)	Ant.Gain (dBi)	Emission level (dBm)	Limit (dBm)	Margin (dB)	Antenna Polarization (V/H)
1105.000	-53.28	4.07	3.46	-53.89	-13.00	-40.89	V
5550.000	-54.31	10.06	10.81	-53.56	-13.00	-40.56	V
N/A							
1105.000	-53.12	4.07	3.46	-53.73	-13.00	-40.73	H
3712.500	-49.76	8.21	9.11	-48.86	-13.00	-35.86	H
5567.500	-46.87	10.11	10.81	-46.17	-13.00	-33.17	H
N/A							

Remark:

1. Measuring frequencies from 1 GHz to the 10th harmonic of highest fundamental frequency.
2. Measurements above show only up to 6 maximum emissions noted, or would be lesser, with " N/A " remark, if no specific emissions from the EUT are recorded (ie: margin > 20dB from the applicable limit) and considered that's already beyond the background noise floor.



Operation Mode: CDMA2000 / 1900 / TX / CH 600

Test Date: September 28, 2011

Temperature: 25°C

Tested by: Edward Lin

Humidity: 50 % RH

Polarity: Ver. / Hor.

Frequency (MHz)	S.G. (dBm)	Cable loss (dB)	Ant.Gain (dBi)	Emission level (dBm)	Limit (dBm)	Margin (dB)	Antenna Polarization (V/H)
1105.000	-52.88	4.07	3.46	-53.49	-13.00	-40.49	V
3765.000	-53.65	8.24	9.16	-52.73	-13.00	-39.73	V
5637.500	-54.19	10.18	10.83	-53.54	-13.00	-40.54	V
N/A							
1105.000	-52.98	4.07	3.46	-53.59	-13.00	-40.59	H
3765.000	-48.56	8.24	9.16	-47.64	-13.00	-34.64	H
5637.500	-45.92	10.18	10.83	-45.27	-13.00	-32.27	H
N/A							

Remark:

1. Measuring frequencies from 1 GHz to the 10th harmonic of highest fundamental frequency.
2. Measurements above show only up to 6 maximum emissions noted, or would be lesser, with " N/A " remark, if no specific emissions from the EUT are recorded (ie: margin > 20dB from the applicable limit) and considered that's already beyond the background noise floor.



Operation Mode: CDMA2000 / 1900 / TX / CH 1175

Test Date: September 28, 2011

Temperature: 25°C

Tested by: Edward Lin

Humidity: 50 % RH

Polarity: Ver. / Hor.

Frequency (MHz)	S.G. (dBm)	Cable loss (dB)	Ant.Gain (dBi)	Emission level (dBm)	Limit (dBm)	Margin (dB)	Antenna Polarization (V/H)
1105.000	-52.97	4.07	3.46	-53.58	-13.00	-40.58	V
3817.500	-43.84	8.28	9.22	-42.90	-13.00	-29.90	V
N/A							
3817.500	-38.35	8.28	9.22	-37.41	-13.00	-24.41	H
5725.000	-48.33	10.22	10.84	-47.71	-13.00	-34.71	H
N/A							

Remark:

1. Measuring frequencies from 1 GHz to the 10th harmonic of highest fundamental frequency.
2. Measurements above show only up to 6 maximum emissions noted, or would be lesser, with " N/A " remark, if no specific emissions from the EUT are recorded (ie: margin > 20dB from the applicable limit) and considered that's already beyond the background noise floor.



Operation Mode: EVDO / 850 / TX / CH 384

Test Date: September 28, 2011

Temperature: 25°C

Tested by: Edward Lin

Humidity: 50 % RH

Polarity: Ver. / Hor.

Frequency (MHz)	S.G. (dBm)	Cable loss (dB)	Ant.Gain (dBi)	Emission level (dBm)	Limit (dBm)	Margin (dB)	Antenna Polarization (V/H)
1682.500	-30.83	5.09	5.97	-29.95	-13.00	-16.95	V
2522.500	-39.94	6.38	6.16	-40.16	-13.00	-27.16	V
3345.000	-56.53	7.51	8.44	-55.60	-13.00	-42.60	V
4867.500	-50.99	9.28	10.39	-49.88	-13.00	-36.88	V
6530.000	-50.73	11.1	11.34	-50.49	-13.00	-37.49	V
N/A							
1682.500	-30.62	5.09	5.97	-29.74	-13.00	-16.74	H
2522.500	-30.16	6.38	6.16	-30.38	-13.00	-17.38	H
3345.000	-45.09	7.51	8.44	-44.16	-13.00	-31.16	H
5865.000	-47.79	10.41	10.87	-47.33	-13.00	-34.33	H
N/A							

Remark:

1. Measuring frequencies from 1 GHz to the 10th harmonic of highest fundamental frequency.
2. Measurements above show only up to 6 maximum emissions noted, or would be lesser, with " N/A " remark, if no specific emissions from the EUT are recorded (ie: margin > 20dB from the applicable limit) and considered that's already beyond the background noise floor.



Operation Mode: EVDO / 850 / TX / CH 777

Test Date: September 28, 2011

Temperature: 25°C

Tested by: Edward Lin

Humidity: 50 % RH

Polarity: Ver. / Hor.

Frequency (MHz)	S.G. (dBm)	Cable loss (dB)	Ant.Gain (dBi)	Emission level (dBm)	Limit (dBm)	Margin (dB)	Antenna Polarization (V/H)
1700.000	-34.27	5.11	5.94	-33.44	-13.00	-20.44	V
2557.500	-40.64	6.43	6.25	-40.82	-13.00	-27.82	V
3905.000	-55.98	8.39	9.31	-55.06	-13.00	-42.06	V
N/A							
1700.000	-32.14	5.11	5.94	-31.31	-13.00	-18.31	H
2557.500	-35.73	6.43	6.25	-35.91	-13.00	-22.91	H
3397.500	-49.1	7.57	8.59	-48.08	-13.00	-35.08	H
7265.000	-25.97	11.97	12.32	-25.62	-13.00	-12.62	H
N/A							

Remark:

1. Measuring frequencies from 1 GHz to the 10th harmonic of highest fundamental frequency.
2. Measurements above show only up to 6 maximum emissions noted, or would be lesser, with " N/A " remark, if no specific emissions from the EUT are recorded (ie: margin > 20dB from the applicable limit) and considered that's already beyond the background noise floor.



Operation Mode: EVDO / 850 / TX / CH 1013

Test Date: September 28, 2011

Temperature: 25°C

Tested by: Edward Lin

Humidity: 50 % RH

Polarity: Ver. / Hor.

Frequency (MHz)	S.G. (dBm)	Cable loss (dB)	Ant.Gain (dBi)	Emission level (dBm)	Limit (dBm)	Margin (dB)	Antenna Polarization (V/H)
1647.500	-29.99	5.04	6.03	-29.00	-13.00	-16.00	V
2487.500	-42.9	6.33	6.08	-43.15	-13.00	-30.15	V
3310.000	-53.1	7.47	8.33	-52.24	-13.00	-39.24	V
5392.500	-54.87	9.81	10.76	-53.92	-13.00	-40.92	V
N/A							
1647.500	-31.86	5.04	6.03	-30.87	-13.00	-17.87	H
2487.500	-30.37	6.33	6.08	-30.62	-13.00	-17.62	H
3310.000	-44.31	7.47	8.33	-43.45	-13.00	-30.45	H
5777.500	-50.05	10.36	10.86	-49.55	-13.00	-36.55	H
N/A							

Remark:

1. Measuring frequencies from 1 GHz to the 10th harmonic of highest fundamental frequency.
2. Measurements above show only up to 6 maximum emissions noted, or would be lesser, with " N/A " remark, if no specific emissions from the EUT are recorded (ie: margin > 20dB from the applicable limit) and considered that's already beyond the background noise floor.



Operation Mode: EVDO / 1900 / TX / CH 25

Test Date: September 28, 2011

Temperature: 25°C

Tested by: Edward Lin

Humidity: 50 % RH

Polarity: Ver. / Hor.

Frequency (MHz)	S.G. (dBm)	Cable loss (dB)	Ant.Gain (dBi)	Emission level (dBm)	Limit (dBm)	Margin (dB)	Antenna Polarization (V/H)
1105.000	-48.44	4.07	3.46	-49.05	-13.00	-36.05	V
3712.500	-46.15	8.21	9.11	-45.25	-13.00	-32.25	V
5567.500	-48.04	10.11	10.81	-47.34	-13.00	-34.34	V
N/A							
1105.000	-51.77	4.07	3.46	-52.38	-13.00	-39.38	H
3712.500	-50.12	8.21	9.11	-49.22	-13.00	-36.22	H
5550.000	-49.94	10.06	10.81	-49.19	-13.00	-36.19	H
N/A							

Remark:

1. Measuring frequencies from 1 GHz to the 10th harmonic of highest fundamental frequency.
2. Measurements above show only up to 6 maximum emissions noted, or would be lesser, with " N/A " remark, if no specific emissions from the EUT are recorded (ie: margin > 20dB from the applicable limit) and considered that's already beyond the background noise floor.



Operation Mode: EVDO / 1900 / TX / CH 600

Test Date: September 28, 2011

Temperature: 25°C

Tested by: Edward Lin

Humidity: 50 % RH

Polarity: Ver. / Hor.

Frequency (MHz)	S.G. (dBm)	Cable loss (dB)	Ant.Gain (dBi)	Emission level (dBm)	Limit (dBm)	Margin (dB)	Antenna Polarization (V/H)
1105.000	-51.98	4.07	3.46	-52.59	-13.00	-39.59	V
3765.000	-43.57	8.24	9.16	-42.65	-13.00	-29.65	V
5637.500	-52.72	10.18	10.83	-52.07	-13.00	-39.07	V
N/A							
1105.000	-51.93	4.07	3.46	-52.54	-13.00	-39.54	H
3765.000	-48.91	8.24	9.16	-47.99	-13.00	-34.99	H
5637.500	-48.72	10.18	10.83	-48.07	-13.00	-35.07	H
N/A							

Remark:

1. Measuring frequencies from 1 GHz to the 10th harmonic of highest fundamental frequency.
2. Measurements above show only up to 6 maximum emissions noted, or would be lesser, with " N/A " remark, if no specific emissions from the EUT are recorded (ie: margin > 20dB from the applicable limit) and considered that's already beyond the background noise floor.



Operation Mode: EVDO / 1900 / TX / CH 1175

Test Date: September 28, 2011

Temperature: 25°C

Tested by: Edward Lin

Humidity: 50 % RH

Polarity: Ver. / Hor.

Frequency (MHz)	S.G. (dBm)	Cable loss (dB)	Ant.Gain (dBi)	Emission level (dBm)	Limit (dBm)	Margin (dB)	Antenna Polarization (V/H)
1105.000	-52.34	4.07	3.46	-52.95	-13.00	-39.95	V
3817.500	-36.59	8.28	9.22	-35.65	-13.00	-22.65	V
5725.000	-41.56	10.22	10.84	-40.94	-13.00	-27.94	V
7650.000	-46.12	12.29	12.85	-45.56	-13.00	-32.56	V
N/A							
1105.000	-53.36	4.07	3.46	-53.97	-13.00	-40.97	H
3817.500	-40.21	8.28	9.22	-39.27	-13.00	-26.27	H
5725.000	-47.86	10.22	10.84	-47.24	-13.00	-34.24	H
N/A							

Remark:

1. Measuring frequencies from 1 GHz to the 10th harmonic of highest fundamental frequency.
2. Measurements above show only up to 6 maximum emissions noted, or would be lesser, with " N/A " remark, if no specific emissions from the EUT are recorded (ie: margin > 20dB from the applicable limit) and considered that's already beyond the background noise floor.



7.6 FREQUENCY STABILITY V.S. TEMPERATURE MEASUREMENT

LIMIT

According to FCC §2.1055, FCC §24.235.

Frequency Tolerance: 2.5 ppm

Test Configuration

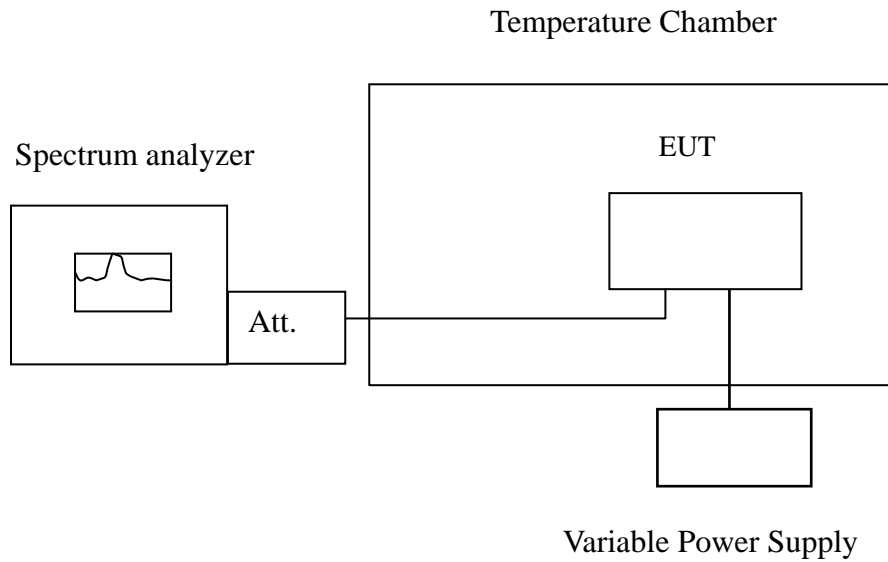

Remark: Measurement setup for testing on Antenna connector



TEST PROCEDURE

The equipment under test was connected to an external AC or DC power supply and input rated voltage. RF output was connected to a frequency counter or spectrum analyzer via feed through attenuators. The EUT was placed inside the temperature chamber. Set the spectrum analyzer RBW low enough to obtain the desired frequency resolution and measure EUT 20°C operating frequency as reference frequency. Turn EUT off and set the chamber temperature to -30°C. After the temperature stabilized for approximately 30 minutes recorded the frequency. Repeat step measure with 10°C increased per stage until the highest temperature of +50°C reached.

TEST RESULTS

No non-compliance noted.

Reference Frequency: CDMA2000 Mid Channel 836.52MHz @ 20°C				
Limit: +/- 2.5 ppm = 2091 Hz				
Power Supply Vdc	Environment Temperature (°C)	Frequency (Hz)	Delta (Hz)	Limit (Hz)
12	50	836520001	0	2091
	40	836520001	0	
	30	836520004	3	
	20	836520001	0	
	10	836520009	8	
	0	836519996	-5	
	-10	836520003	2	
	-20	836519998	-3	
	-30	836520000	-1	

Reference Frequency: CDMA2000 Mid Channel 1880MHz @ 20°C				
Limit: +/- 2.5 ppm = 4700 Hz				
Power Supply Vdc	Environment Temperature (°C)	Frequency (Hz)	Delta (Hz)	Limit (Hz)
12	50	1880000000	-7	4700
	40	1879999996	-11	
	30	1880000021	14	
	20	1880000007	0	
	10	1880000002	-5	
	0	1880000003	-4	
	-10	1879999995	-12	
	-20	1879999997	-10	
	-30	1880000004	-3	



Reference Frequency: EVDO Mid Channel 836.52MHz @ 20°C				
Limit: +/- 2.5 ppm = 2091 Hz				
Power Supply Vdc	Environment Temperature (°C)	Frequency (Hz)	Delta (Hz)	Limit (Hz)
12	50	836519999	5	2091
	40	836519997	3	
	30	836520004	10	
	20	836519994	0	
	10	836520005	11	
	0	836520001	7	
	-10	836520000	6	
	-20	836519999	5	
	-30	836520002	8	

Reference Frequency: EVDO Mid Channel 1880MHz @ 20°C				
Limit: +/- 2.5 ppm = 4700 Hz				
Power Supply Vdc	Environment Temperature (°C)	Frequency (Hz)	Delta (Hz)	Limit (Hz)
12	50	1880000000	1	4700
	40	1879999998	-1	
	30	1880000002	3	
	20	1879999999	0	
	10	1880000008	9	
	0	1880000003	4	
	-10	1880000000	1	
	-20	1879999997	-2	
	-30	1880000001	2	



7.7 FREQUENCY STABILITY V.S. VOLTAGE MEASUREMENT

LIMIT

According to FCC §2.1055, FCC §24.235,

Frequency Tolerance: 2.5 ppm.

Test Configuration

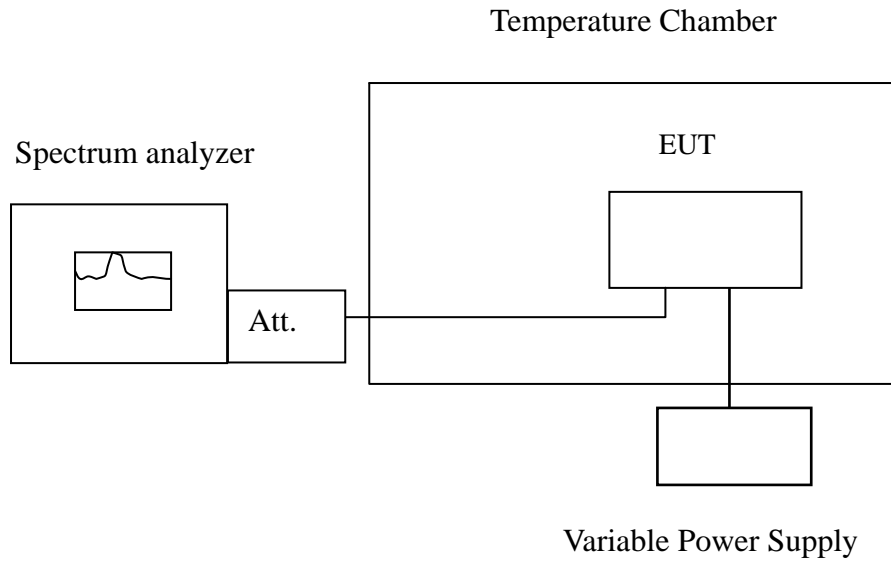

Remark: Measurement setup for testing on Antenna connector.



TEST PROCEDURE

Set chamber temperature to 20°C. Use a variable AC power supply / DC power source to power the EUT and set the voltage to rated voltage. Set the spectrum analyzer RBW low enough to obtain the desired frequency resolution and recorded the frequency.

Reduce the input voltage to specify extreme voltage variation ($\pm 15\%$) and endpoint, record the maximum frequency change.

TEST RESULTS

No non-compliance noted.

Reference Frequency: CDMA2000 Mid Channel 836.52MHz @ 20°C				
Limit: +/- 2.5 ppm = 2091 Hz				
Power Supply Vdc	Environment Temperature (°C)	Frequency (Hz)	Delta (Hz)	Limit (Hz)
13.8	20	836520001	1	2091
12		836520000	0	
11		836519924	-76	
11END		836519916	-84	

Reference Frequency: CDMA2000 Mid Channel 1880MHz @ 20°C				
Limit: ± 2.5 ppm = 4700 Hz				
Power Supply Vdc	Environment Temperature (°C)	Frequency (Hz)	Delta (Hz)	Limit (Hz)
13.8	20	1880000000	-7	4700
12		1880000007	0	
11		1880000058	51	
11END		1880000069	62	



Reference Frequency: EVDO Mid Channel 836.52MHz @ 20°C				
Limit: +/- 2.5 ppm = 2091 Hz				
Power Supply Vdc	Environment Temperature (°C)	Frequency (Hz)	Delta (Hz)	Limit (Hz)
13.8	20	836520000	-2	2091
12		836520002	0	
11		836519923	-79	
11END		836519911	-91	

Reference Frequency: EVDO Mid Channel 1880MHz @ 20°C				
Limit: ± 2.5 ppm = 4700 Hz				
Power Supply Vdc	Environment Temperature (°C)	Frequency (Hz)	Delta (Hz)	Limit (Hz)
13.8	20	1880000007	8	4700
12		1879999999	0	
11		1880000081	82	
11END		1880000073	74	



7.8 POWERLINE CONDUCTED EMISSIONS

LIMIT

For an intentional radiator which is designed to be connected to the public utility (AC) power line, the radio frequency voltage that is conducted back onto the AC power line on any frequency or frequencies within the band 150 kHz to 30 MHz shall not exceed 250 microvolts (The limit decreases linearly with the logarithm of the frequency in the range 0.15 MHz to 0.50 MHz). The limits at specific frequency range is listed as follows:

Frequency Range (MHz)	Limits (dB μ V)	
	Quasi-peak	Average
0.15 to 0.50	66 to 56	56 to 46
0.50 to 5	56	46
5 to 30	60	50

Compliance with this provision shall be based on the measurement of the radio frequency voltage between each power line (LINE and NEUTRAL) and ground at the power terminals.

Test Configuration

See test photographs attached in Appendix 1 for the actual connections between EUT and support equipment.

TEST PROCEDURE

1. The EUT was placed on a table, which is 0.8m above ground plane.
2. Maximum procedure was performed on the six highest emissions to ensure EUT compliance.
3. Repeat above procedures until all frequency measured were complete.

TEST RESULTS

Not applicable, because the EUT is not connected to the AC main source.