



TAOGLAS®

Datasheet

[PCUB77.A.07.A.001]

Part No:
PCUB77.A.07.A.001

Description

2*LTE MIMO

Features:

2* LTE MIMO 698 to 960MHz/1710 to 2170MHz/ 2490 to 2690MHz

1. Introduction.....	2
2. Specification	3
3. Test Setup	5
4. Antenna Characteristics.....	8
5. Radiation Patterns	11
6. Mechanical Drawing	25
7. Packaging.....	26

Taoglas makes no warranties based on the accuracy or completeness of the contents of this document and reserves the right to make changes to specifications and product descriptions at any time without notice. Taoglas reserves all rights to this document and the information contained herein. Reproduction, use or disclosure to third parties without express permission is strictly prohibited.



Introduction



LTE Antenna for Portable Box PC

Specification

Electrical															
Frequency (MHz)	B12_TX	B28_TX	B12_RX	B13_RX	B28_RX	B13_TX	B20_RX	B5_TX	B20_TX	B5_RX	B8_TX	B8_RX	B32_RX	B4_TX	B66_TX
	699-716	703-748	729-746	746-756	758-803	777-787	791-821	824-849	832-862	869-894	880-915	925-960	1452-1496	1710-1755	1710-1780
Efficiency (%)															
Aux	11.5	18.0	21.5	25.4	42.3	40.2	57.1	63.1	57.7	42.3	36.9	21.9	44.1	58.9	59.6
Main	43.5	48.2	50.4	49.8	50.4	50.9	47.6	43.7	38.9	41.6	48.9	59.2	4.9	57.2	57.5
Average Gain (dB)															
Aux	-9.38	-7.45	-6.68	-5.95	-3.73	-3.96	-2.43	-2.00	-2.39	-3.74	-4.32	-6.60	-3.56	-2.30	-2.25
Main	-3.61	-3.17	-2.98	-3.03	-2.98	-2.93	-3.23	-3.60	-4.10	-3.81	-3.11	-2.28	-13.12	-2.43	-2.41
Peak Gain (dBi)															
Aux	-4.88	-2.31	-2.31	-1.86	1.69	0.21	2.10	2.35	2.35	1.64	1.05	-0.61	1.92	3.59	3.73
Main	1.34	2.33	2.33	2.49	3.30	3.30	3.09	2.65	2.73	2.35	3.96	4.71	-6.92	2.90	3.21

Electrical															
Frequency (MHz)	B3_TX	B3_RX	B2_TX	B1_TX	B2_RX	B4_RX	B1_RX	B66_RX	B41	B7_TX	B7_RX	B42	B48_TX	B43	B46
	1710-1785	1805-1880	1850-1910	1920-1980	1930-1990	2110-2155	2110-2170	2110-2200	2496-2690	2500-2570	2620-2690	3400-3600	3500-3700	3600-3800	5150-5925
Efficiency (%)															
Aux	60.0	62.5	57.3	49.6	47.7	56.9	58.2	59.2	45.4	51.2	40.3	36.2	38.3	38.8	3.1
Main	57.5	56.8	55.2	56.1	55.6	52.6	51.8	51.8	56.1	55.8	56.8	51.6	48.4	46.2	22.3
Average Gain (dB)															
Aux	-2.22	-2.04	-2.42	-3.04	-3.21	-2.45	-2.35	-2.28	-3.43	-2.91	-3.94	-4.42	-4.17	-4.11	-15.09
Main	-2.40	-2.45	-2.58	-2.51	-2.55	-2.79	-2.86	-2.86	-2.51	-2.54	-2.46	-2.88	-3.15	-3.35	-6.52
Peak Gain (dBi)															
Aux	3.83	4.47	4.30	3.23	3.06	4.00	4.18	4.41	3.32	3.32	2.54	1.81	2.33	2.33	-3.26
Main	3.21	3.60	3.21	3.20	3.15	3.85	3.85	3.85	3.53	3.37	3.53	7.13	7.13	7.13	2.86

Mechanical	
Dimensions	250*37.2*0.75 (w/o cable)
Weight	FR4
Material	I-PEX MFH4L
Connector	Cable 1: 263.5mm/Cable 2: 194.5mm
Cable	1.13mm coaxial cable
Environmental	
Waterproof Rating	-40°C to 85°C
Temperature Range	-40°C to 85°C
Humidity	40% to 95%

Test Setup

S11 / VSWR / Return Loss

AUT



Vector Network Analyzer



S12 / Isolation

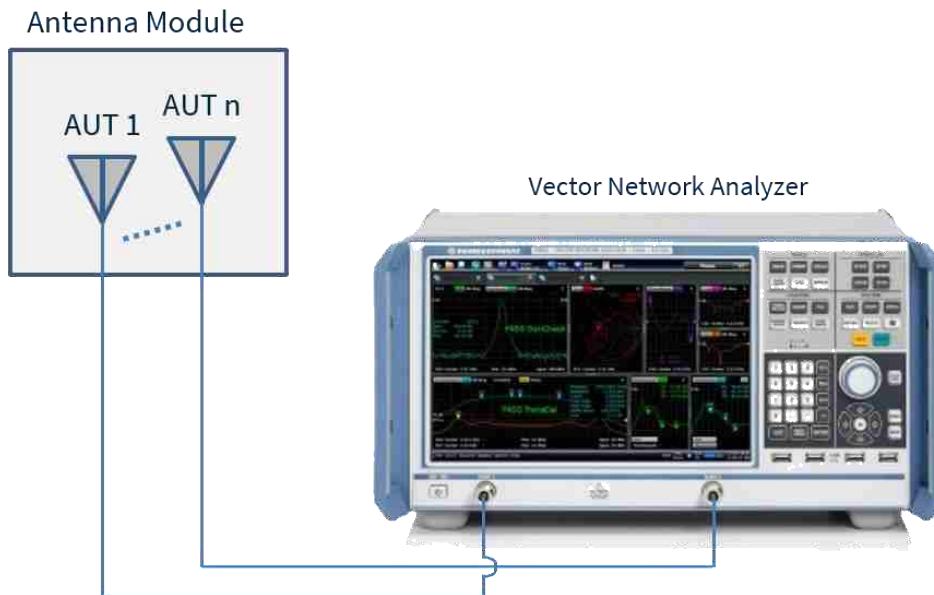

Radiation Performance

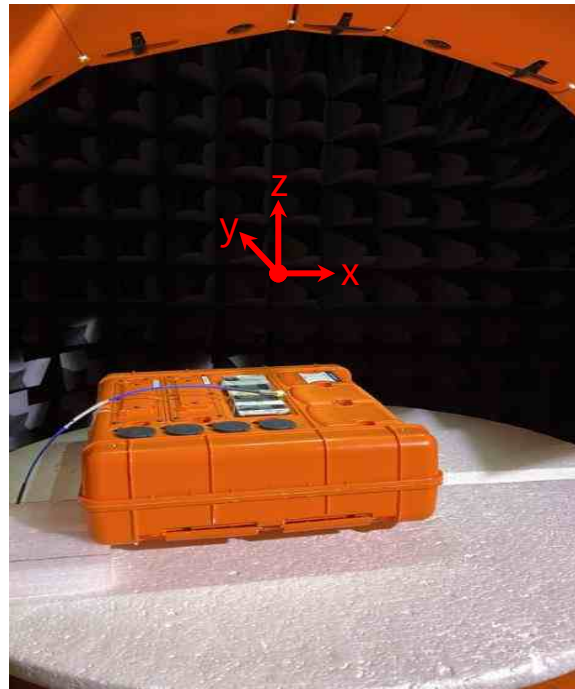
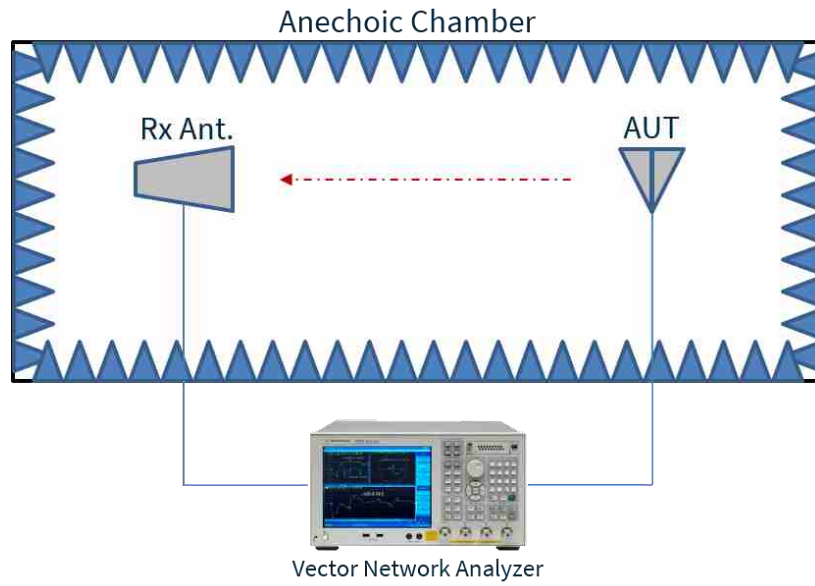

Antenna Characteristics

Return Loss

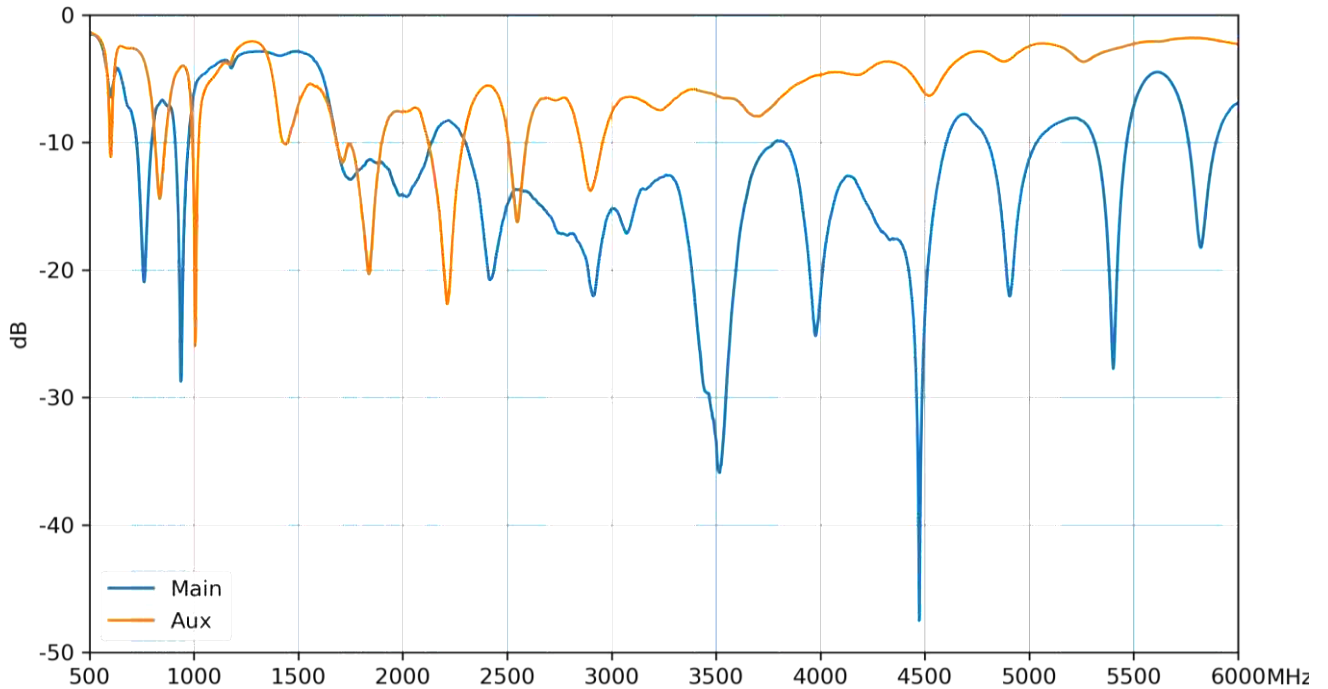

Isolation

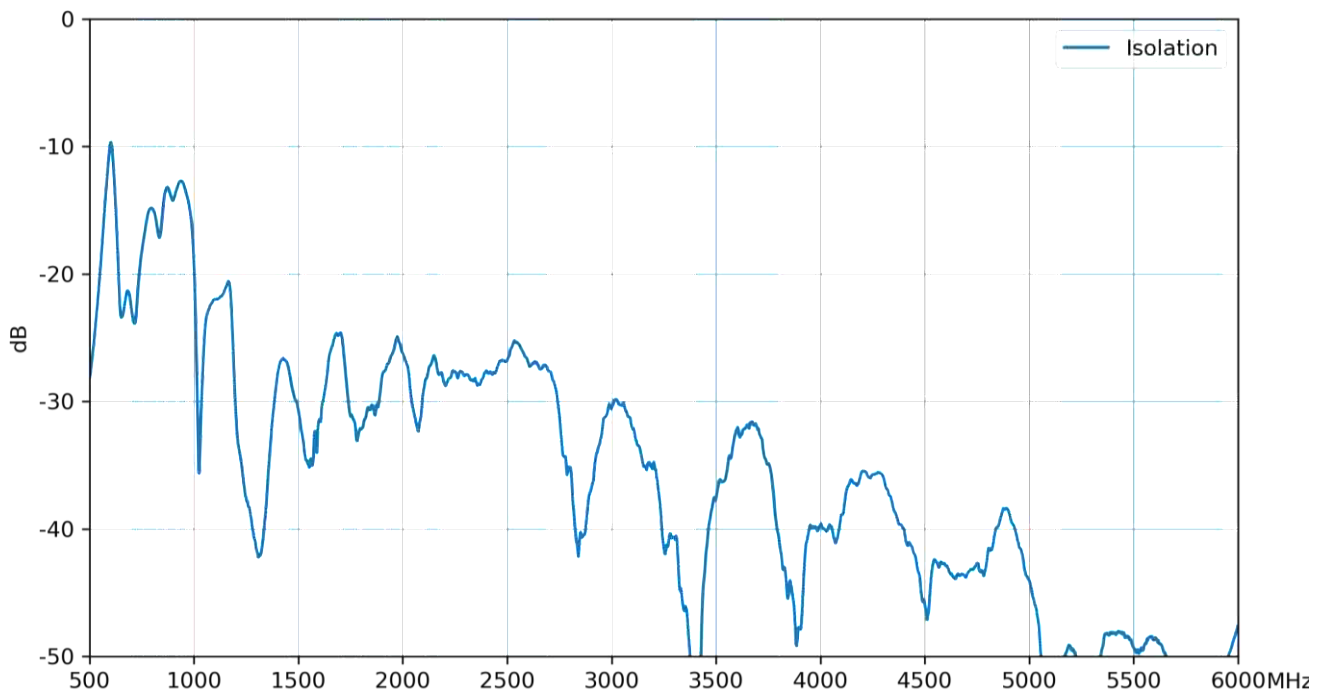

Efficiency

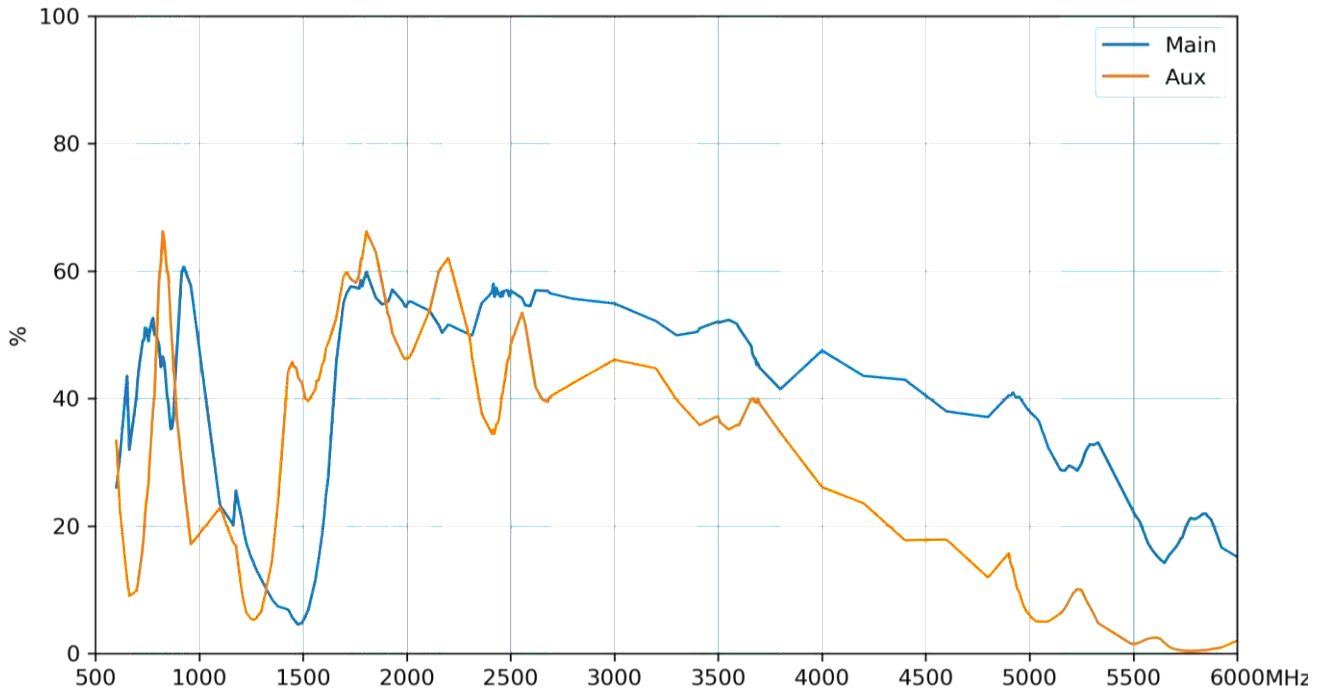

Average Gain

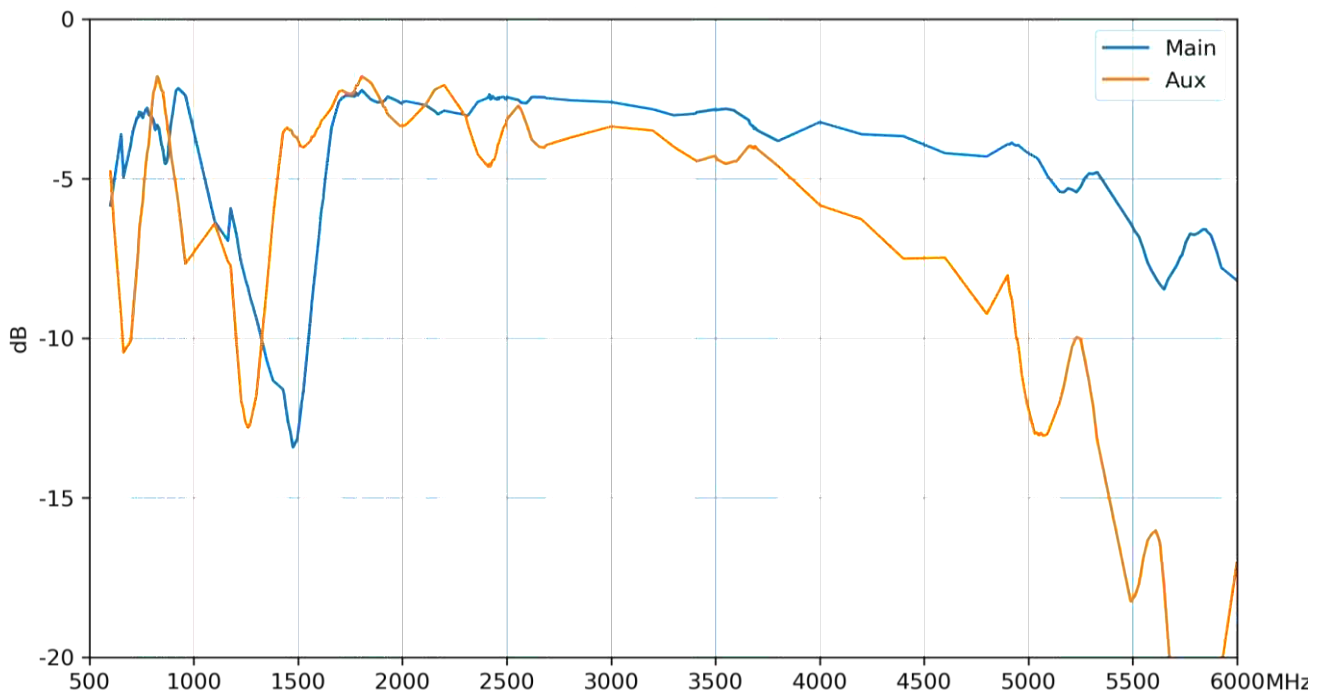

Peak Gain

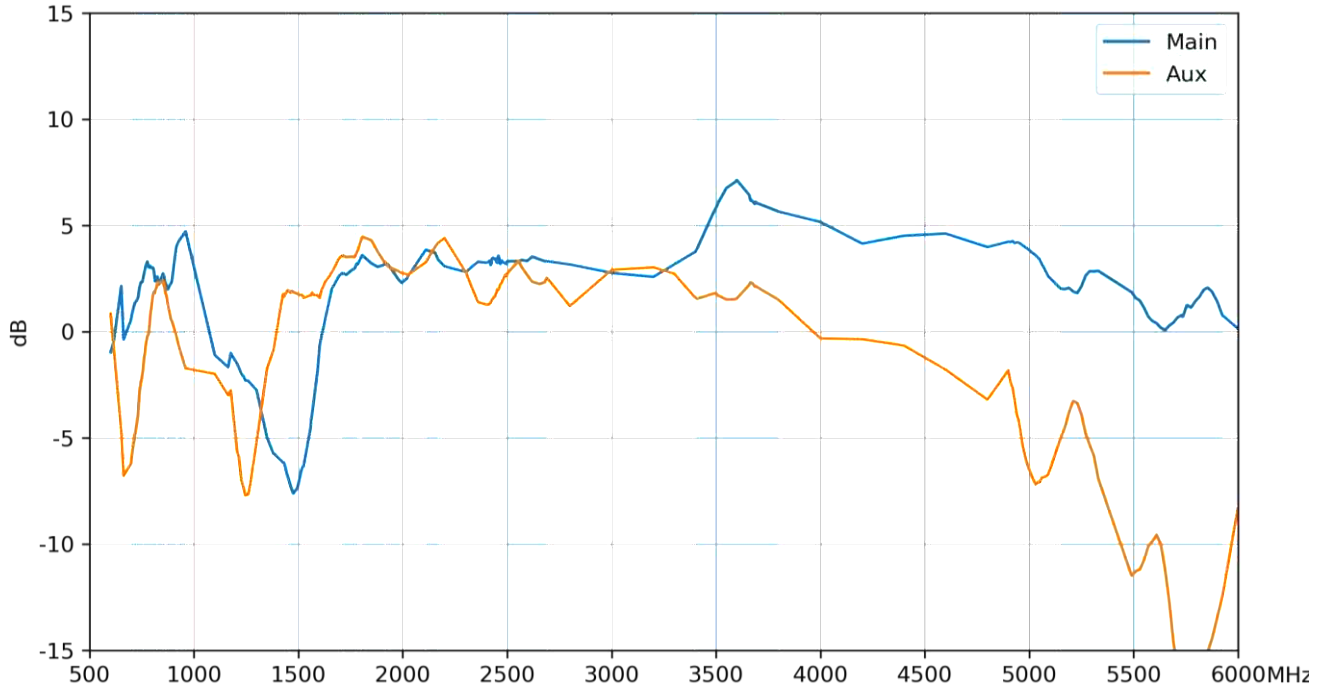

Radiation Patterns

Test Data Main 3D and 2D Radiation Patterns

Gain total, 751MHz

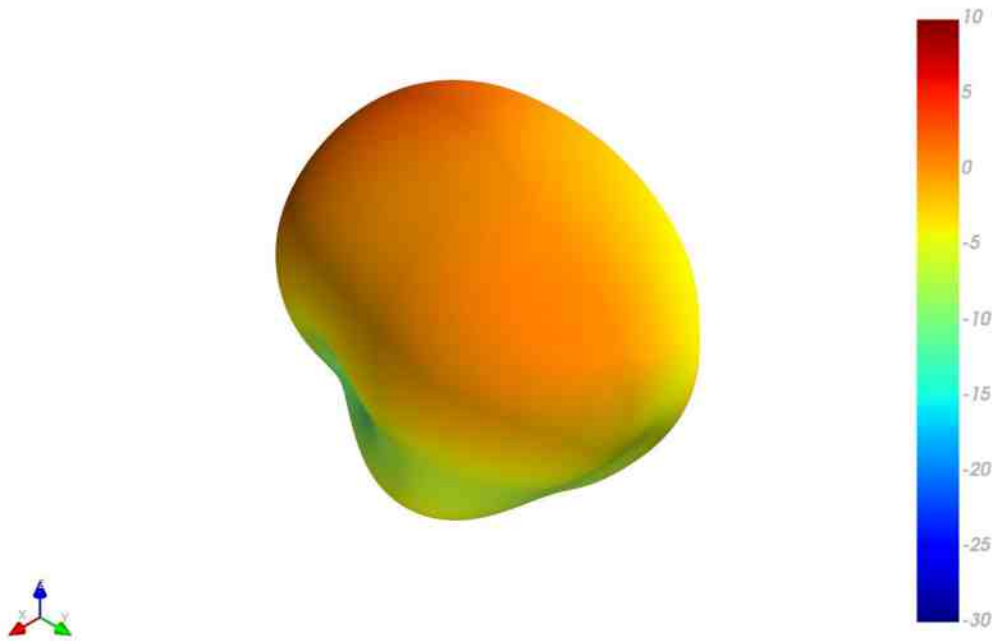

XY Plane XZ Plane YZ Plane

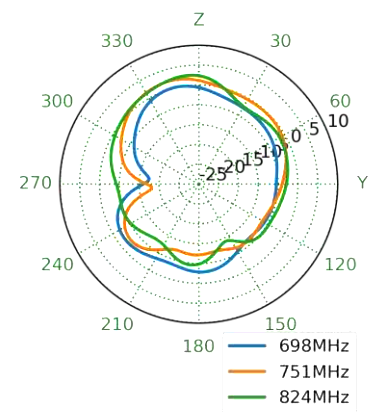
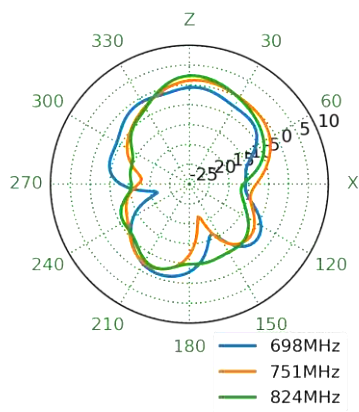
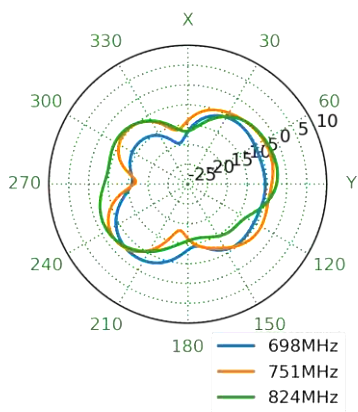

Gain total, 890MHz

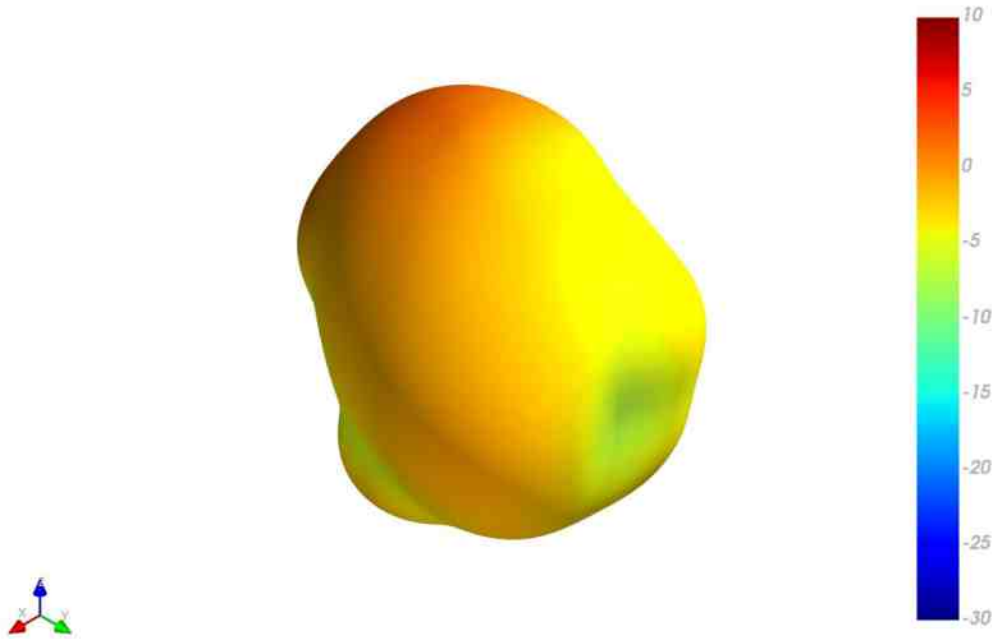

XY Plane XZ Plane YZ Plane

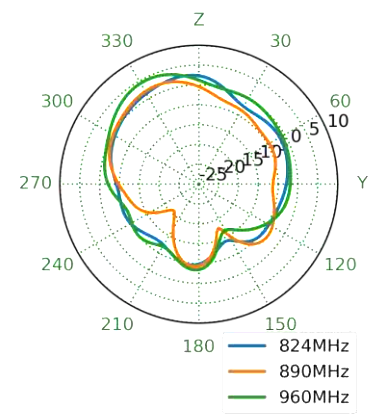
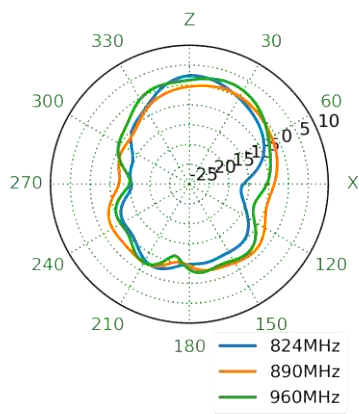
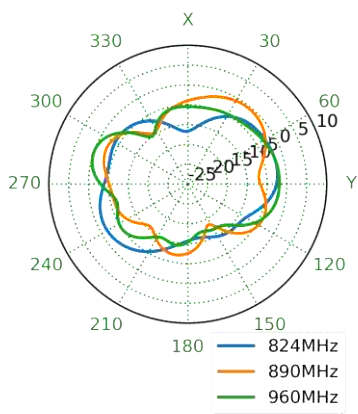

Gain total, 1470MHz

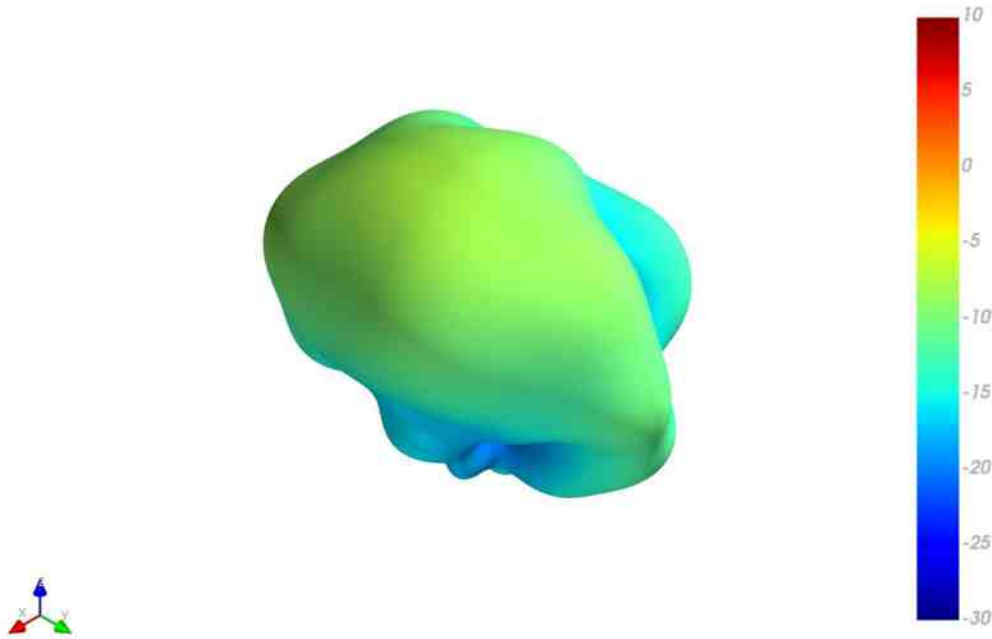

XY Plane XZ Plane YZ Plane

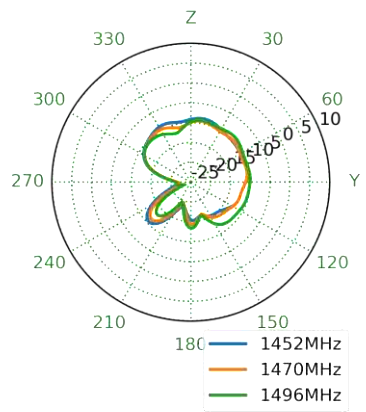
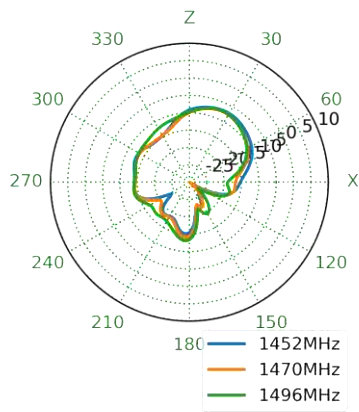
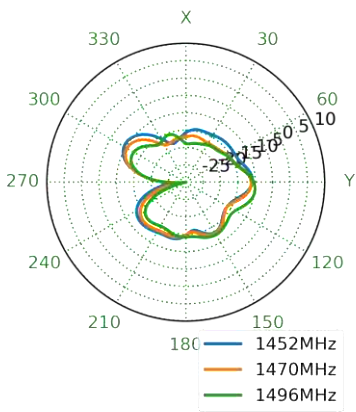

Gain total, 1930MHz

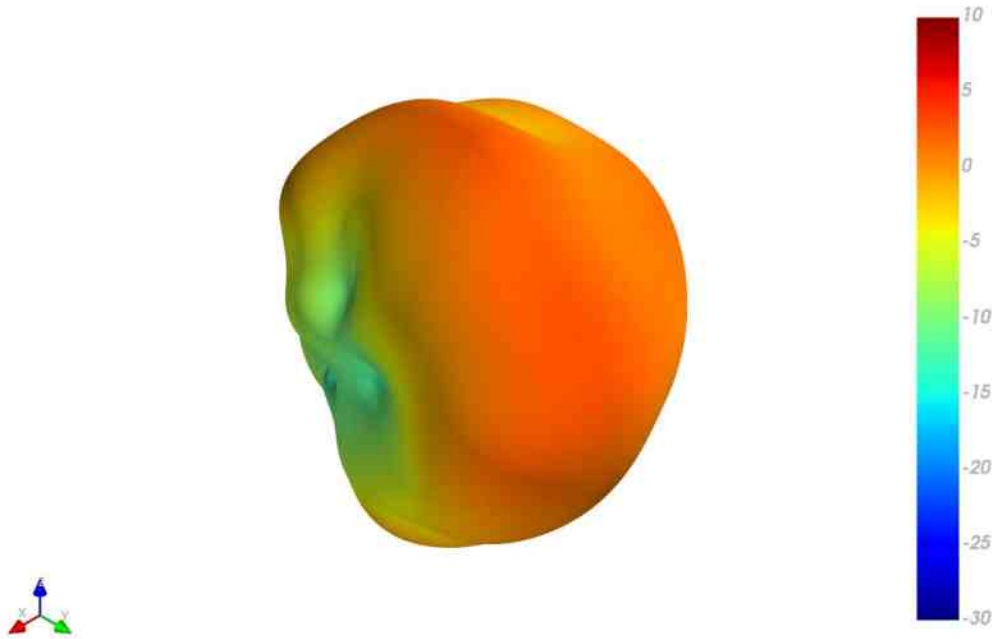

XY Plane XZ Plane YZ Plane

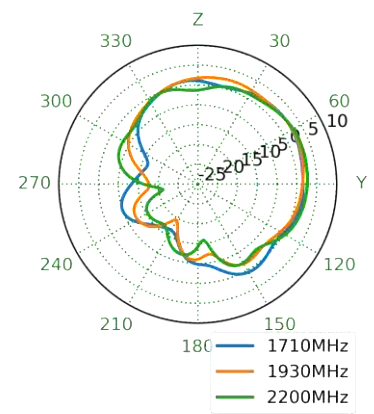
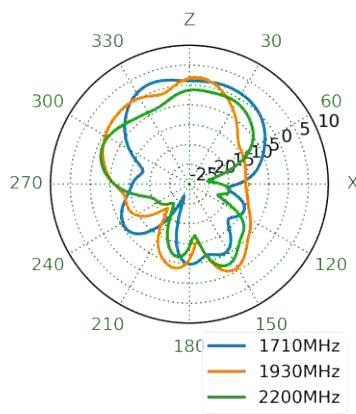
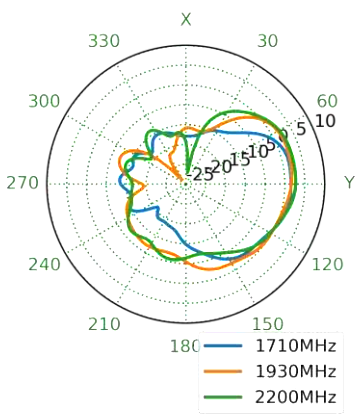

Gain total, 2500MHz

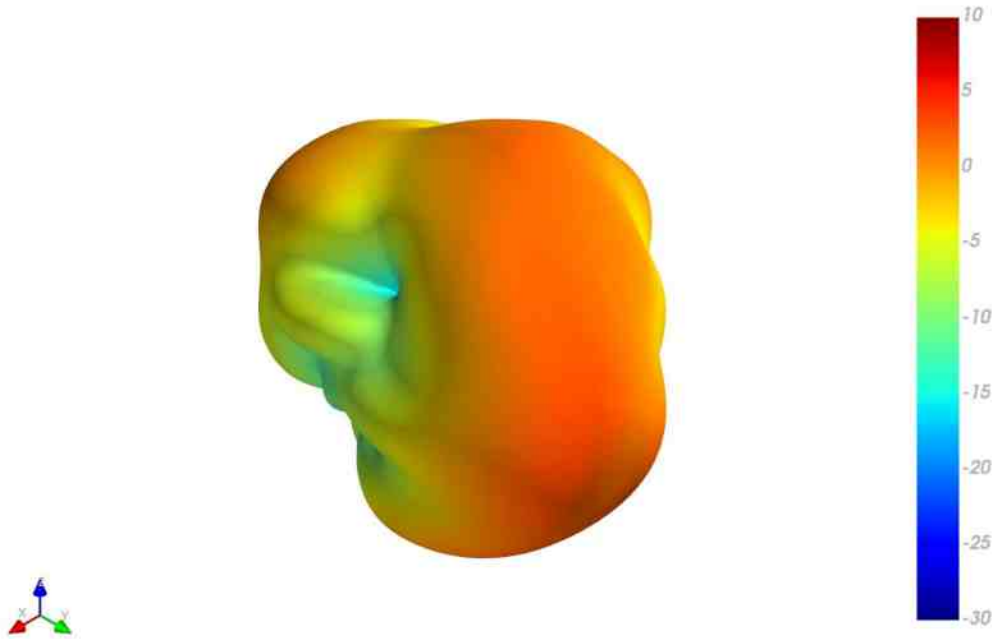

XY Plane XZ Plane YZ Plane

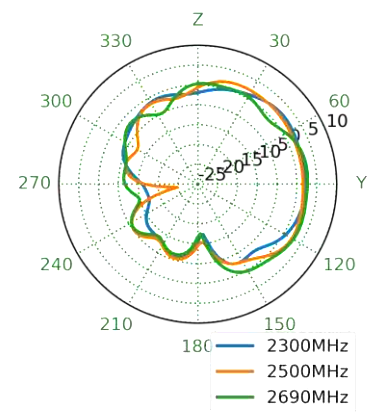
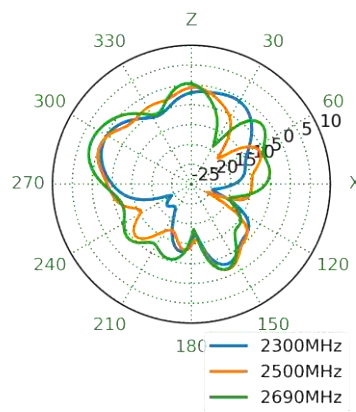
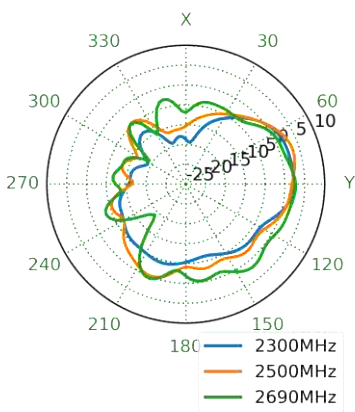

Gain total, 3550MHz

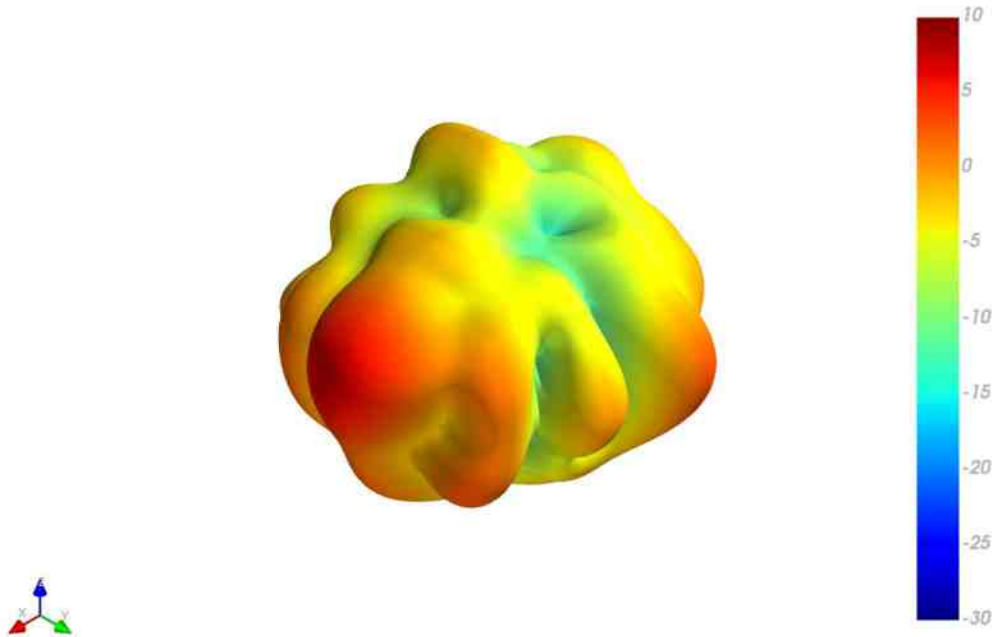

XY Plane XZ Plane YZ Plane

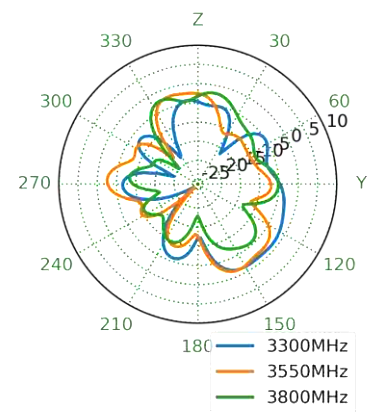
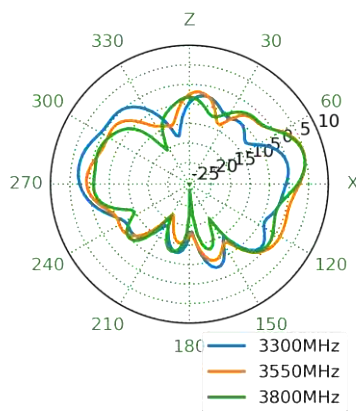
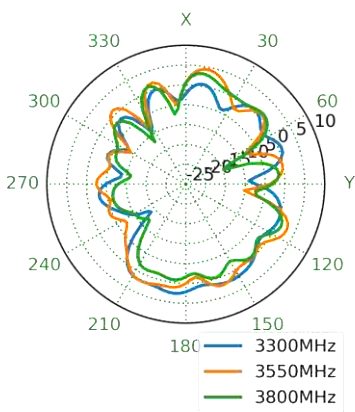

Gain total, 5490MHz

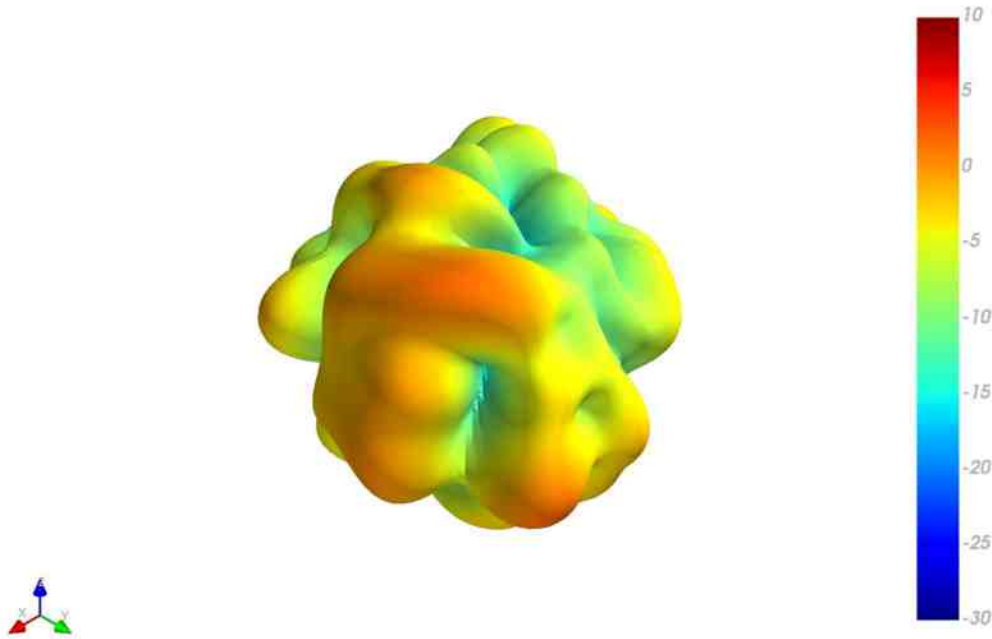

XY Plane XZ Plane YZ Plane

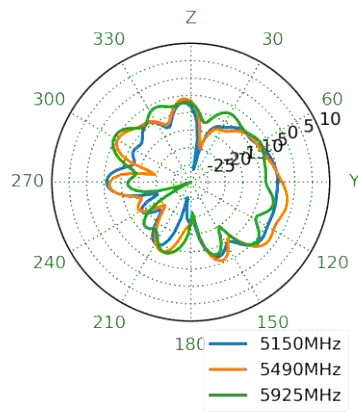
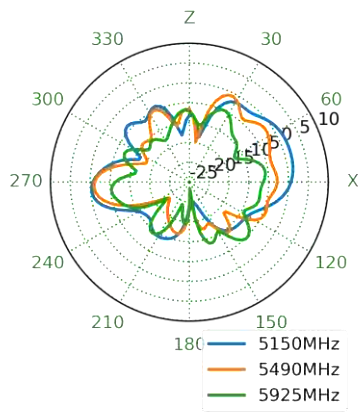
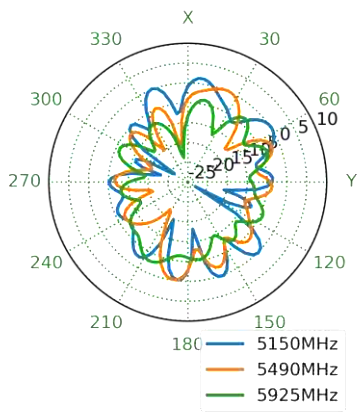

Test Data Aux 3D and 2D Radiation Patterns

Gain total, 751MHz

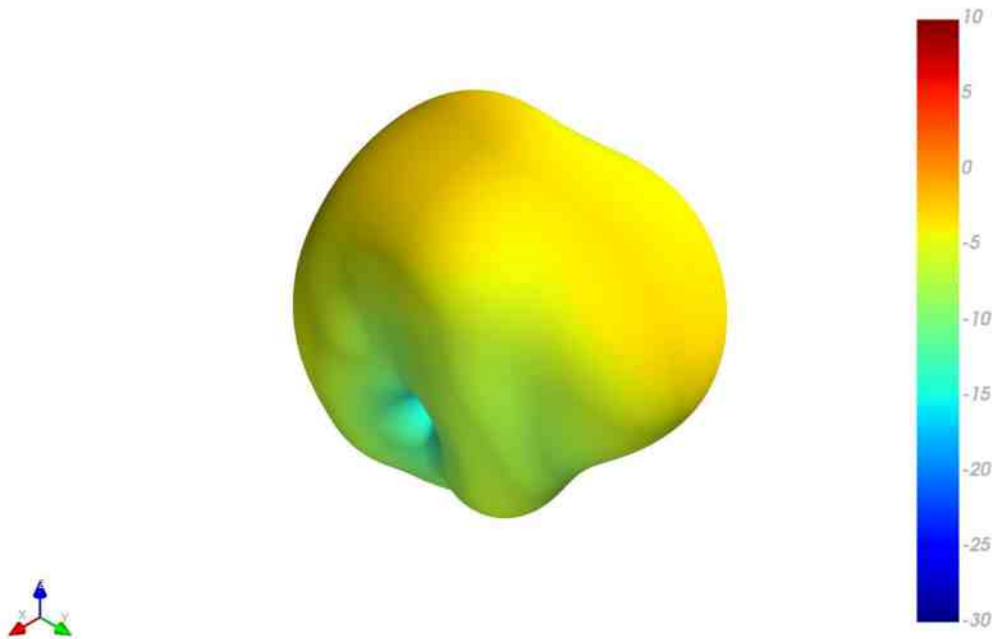

XY Plane

XZ Plane

YZ Plane

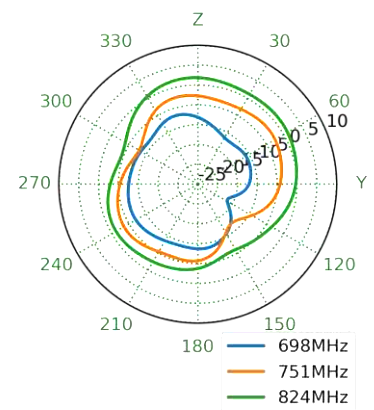
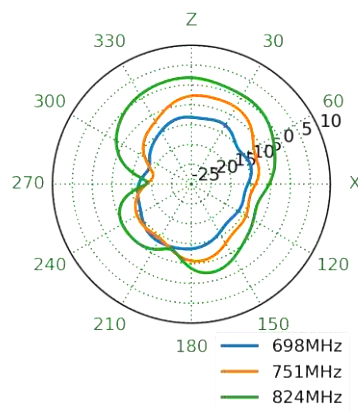
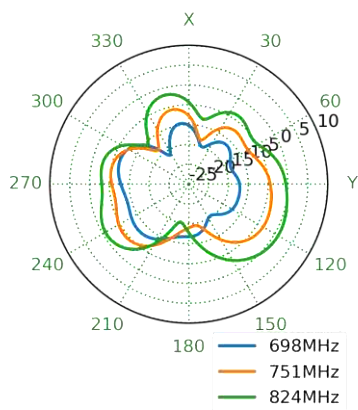

Gain total, 890MHz

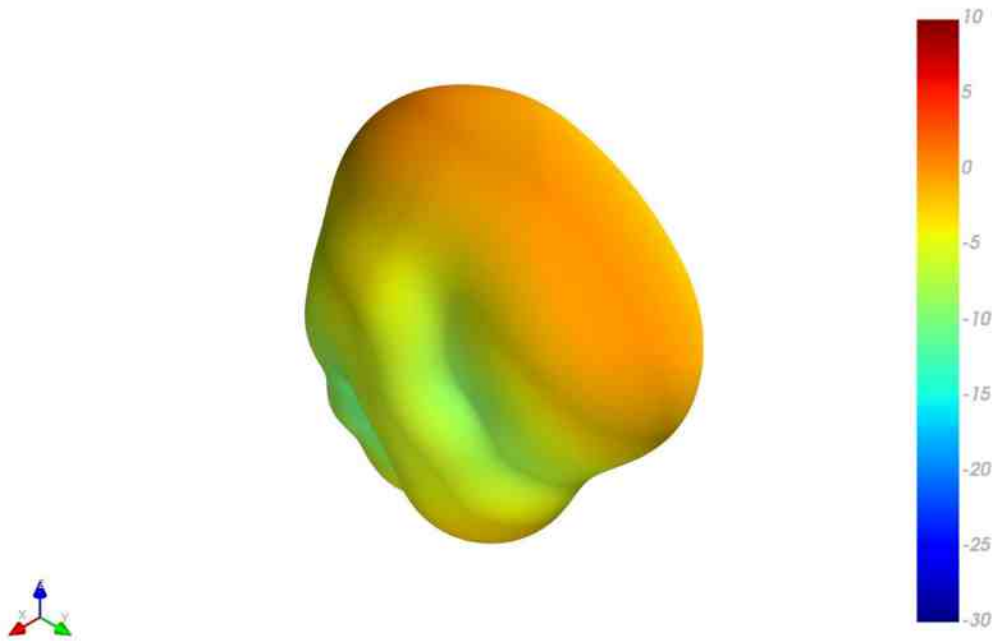

XY Plane XZ Plane YZ Plane

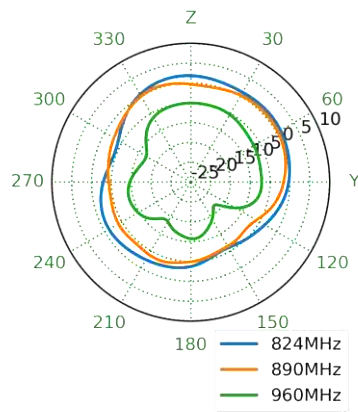
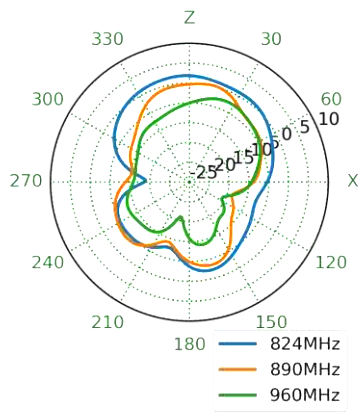
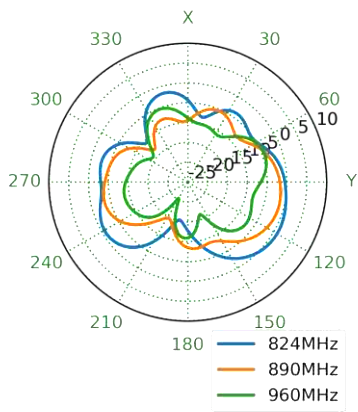

Gain total, 1470MHz

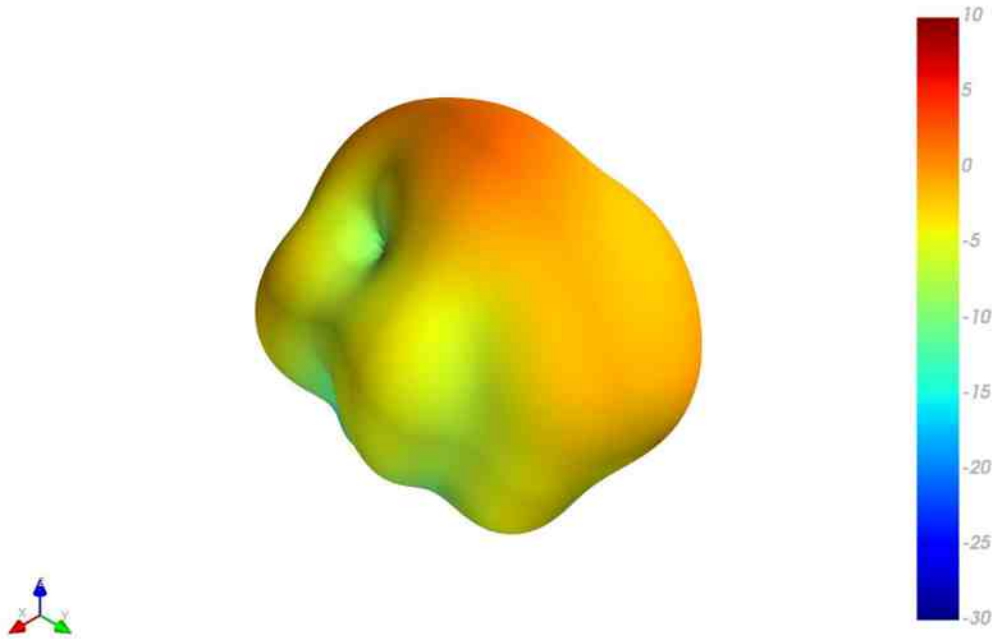

XY Plane XZ Plane YZ Plane

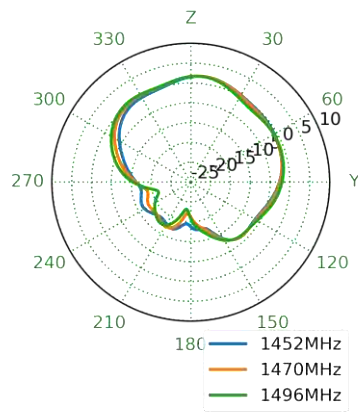
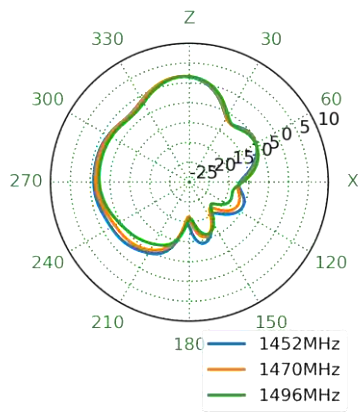
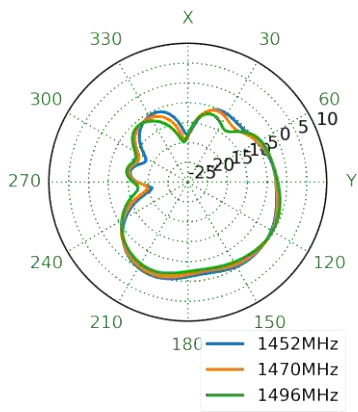

Gain total, 1930MHz

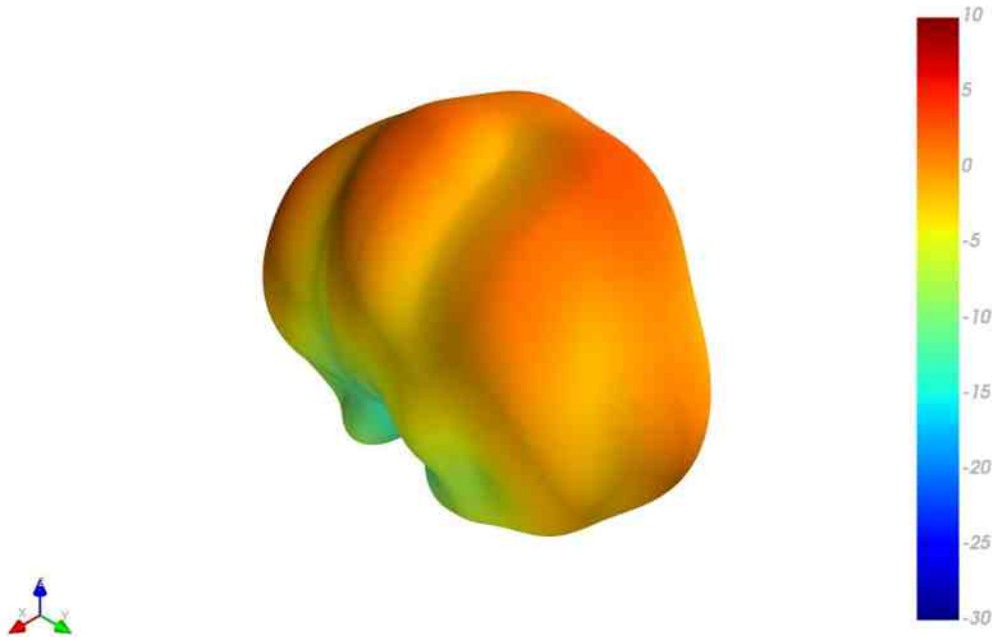

XY Plane XZ Plane YZ Plane

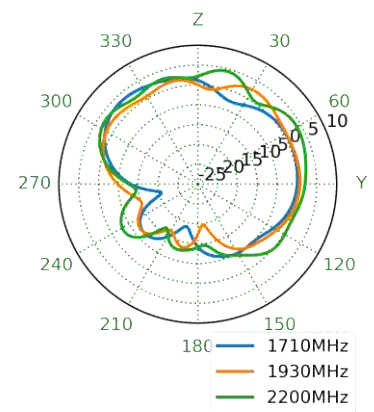
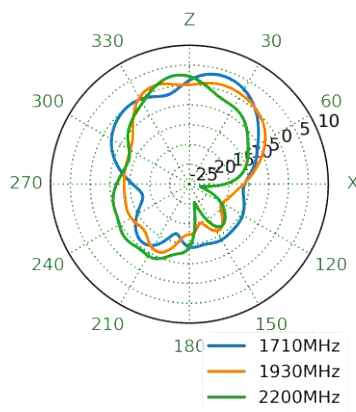
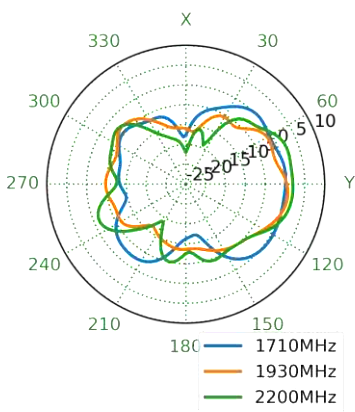

Gain total, 2500MHz

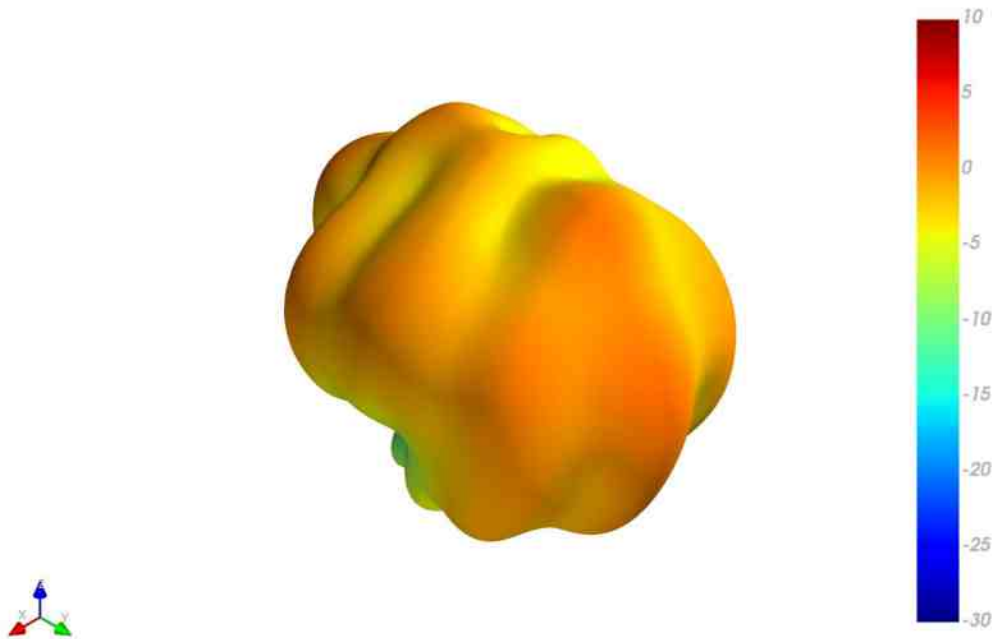

XY Plane XZ Plane YZ Plane

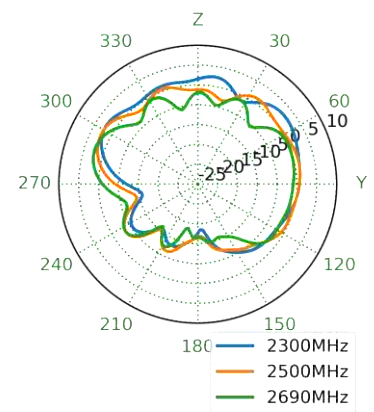
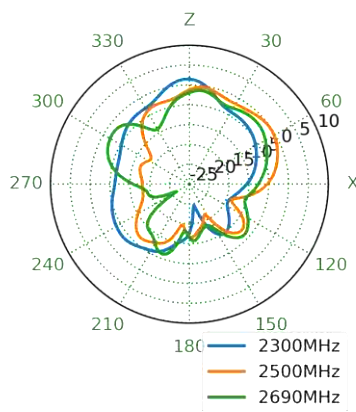
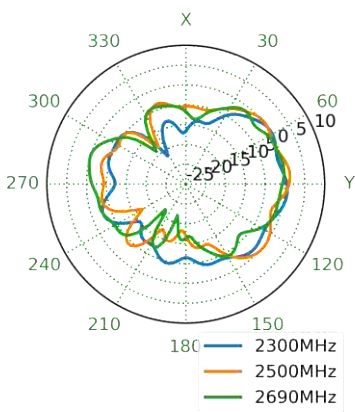

Gain total, 3550MHz

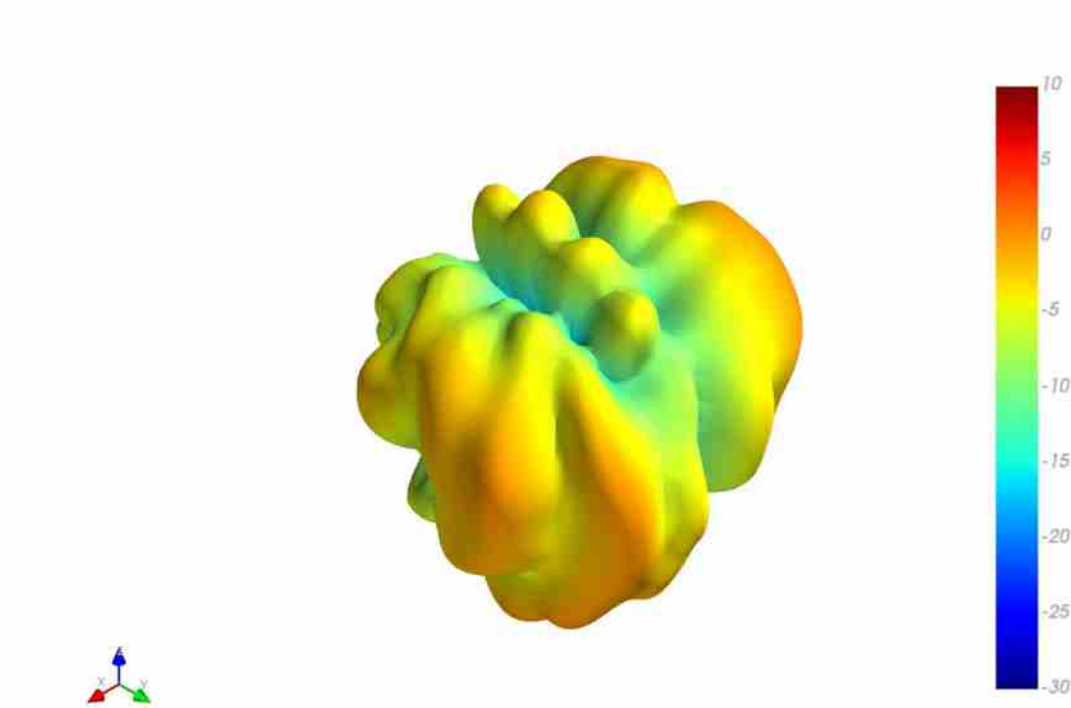

XY Plane XZ Plane YZ Plane

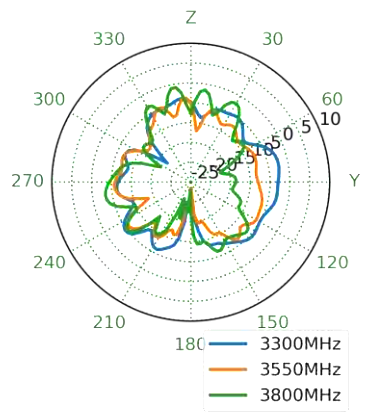
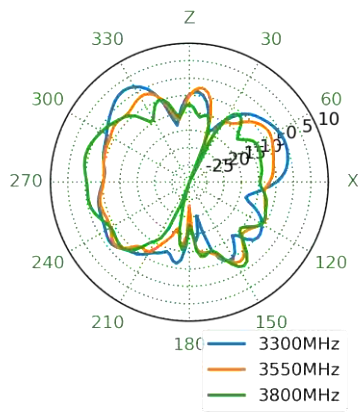
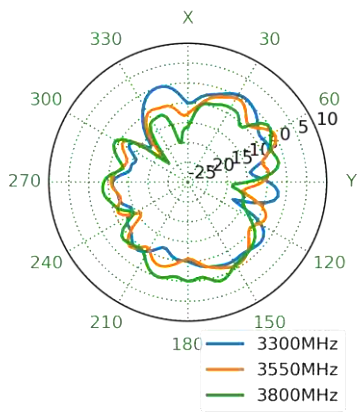

Gain total, 5490MHz

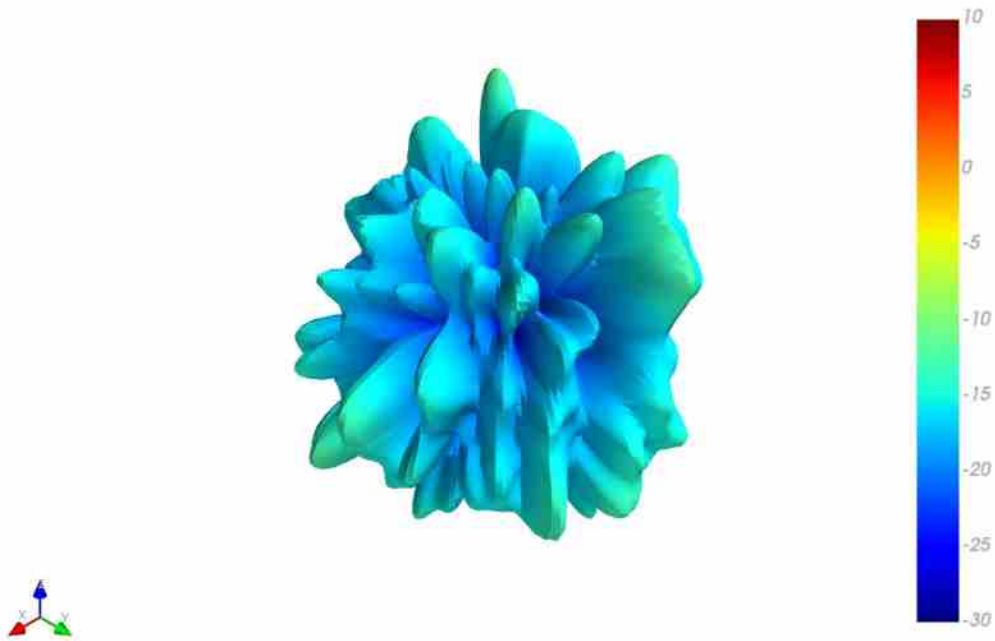

XY Plane XZ Plane YZ Plane

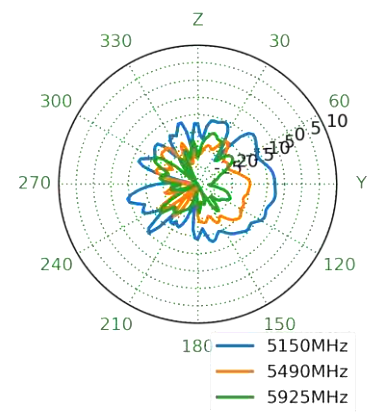
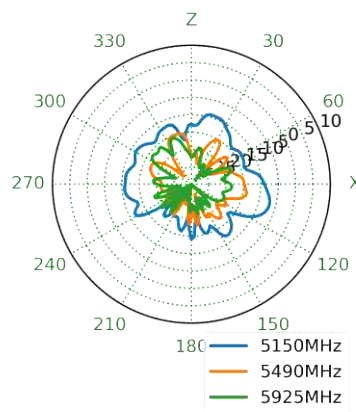
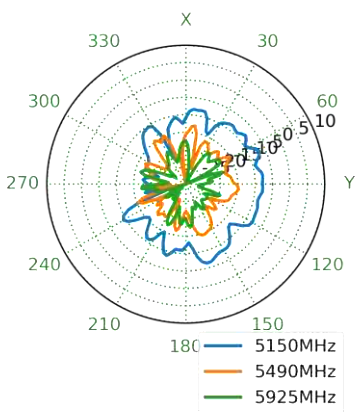

Mechanical Drawing

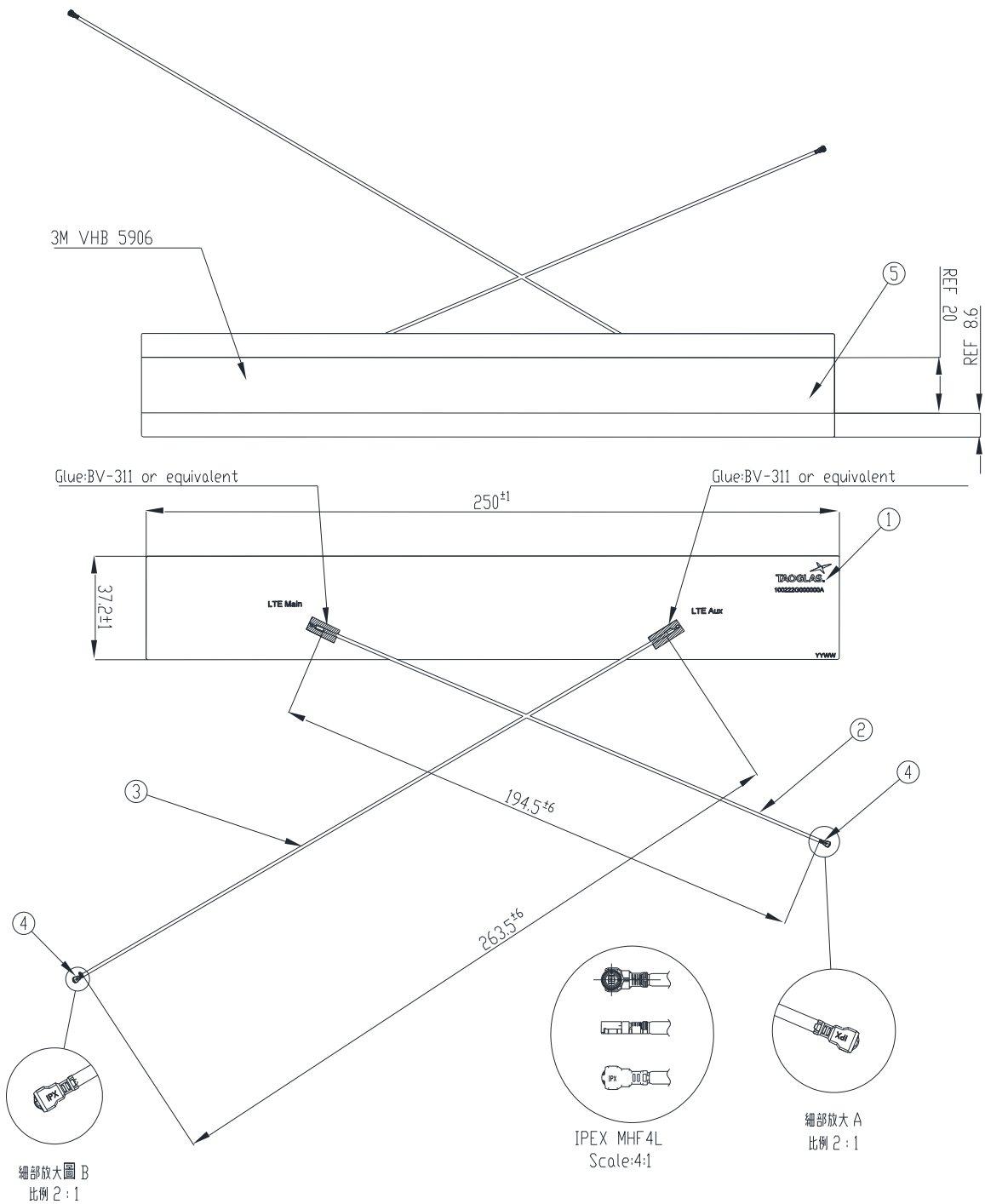

	Name	Material	Finish	QTY
1	PCB	PCB	Black	1
2	1.13 Coaxial cable	FEP	Black	1
3	1.13 Coaxial Cable	FEP	Gray	1
4	IPEX MHF4L	Brass	Au/Ni Plated	2
5	3M VHB 5906		Black	1

Packaging

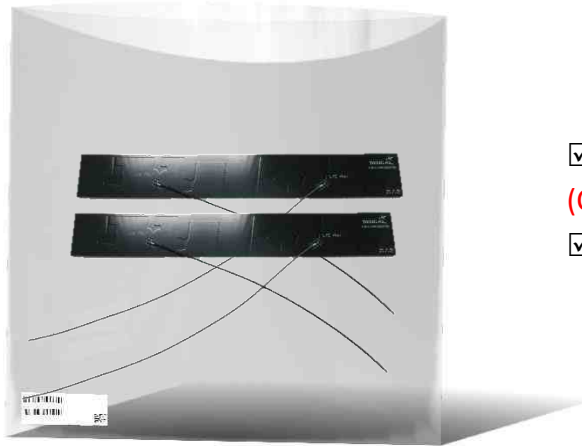

- 20 PCS / PE bag
(Connector needs protective cover)
- SPQ Label



- 400 PCS / Carton
- Carton(mm): 320x250x230
- Carton Label



www.taoglas.com

