



A D T

# FCC TEST REPORT (PART 24)

**REPORT NO.:** RF130521C18H-1

**MODEL NO.:** PWS-770xxxxxxxxxxxxxxxxxxx ("x" can be 0-9 or A-Z or blank or any alphanumeric character for marketing purpose)

**FCC ID:** M82-PWS-770PH

**RECEIVED:** Oct. 01, 2013

**TESTED:** Oct. 02, 2013

**ISSUED:** Oct. 08, 2013

**APPLICANT:** ADVANTECH CO., LTD

**ADDRESS:** No.1, Alley 20, Lane 26, Rueiguang Rd, Neihu District, Taipei, Taiwan 114

**ISSUED BY:** Bureau Veritas Consumer Products Services (H.K.) Ltd., Taoyuan Branch

**LAB ADDRESS:** No. 47, 14th Ling, Chia Pau Vil., Lin Kou Dist., New Taipei City, Taiwan, R.O.C.

**TEST LOCATION:** No. 19, Hwa Ya 2nd Rd, Wen Hwa Tsuen, Kwei Shan Hsiang, Taoyuan Hsien 333, Taiwan, R.O.C.

This report should not be used by the client to claim product certification, approval, or endorsement by TAF or any government agencies.



This report is for your exclusive use. Any copying or replication of this report to or for any other person or entity, or use of our name or trademark, is permitted only with our prior written permission. This report sets forth our findings solely with respect to the test samples identified herein. The results set forth in this report are not indicative or representative of the quality or characteristics of the lot from which a test sample was taken or any similar or identical product unless specifically and expressly noted. Our report includes all of the tests requested by you and the results thereof based upon the information that you provided to us. You have 60 days from date of issuance of this report to notify us of any material error or omission caused by our negligence, provided, however, that such notice shall be in writing and shall specifically address the issue you wish to raise. A failure to raise such issue within the prescribed time shall constitute your unqualified acceptance of the completeness of this report, the tests conducted and the correctness of the report contents. Unless specific mention, the uncertainty of measurement has been explicitly taken into account to declare the compliance or non-compliance to the specification.

## TABLE OF CONTENTS

|  |    |
|--|----|
| RELEASE CONTROL RECORD.....  | 3  |
| 1 CERTIFICATION .....  | 4  |
| 2 SUMMARY OF TEST RESULTS.....   | 5  |
| 2.1 MEASUREMENT UNCERTAINTY .....  | 5  |
| 2.2 TEST SITE AND INSTRUMENTS.....   | 6  |
| 3 GENERAL INFORMATION .....  | 7  |
| 3.1 GENERAL DESCRIPTION OF EUT .....   | 7  |
| 3.2 CONFIGURATION OF SYSTEM UNDER TEST.....  | 8  |
| 3.3 DESCRIPTION OF SUPPORT UNITS.....  | 9  |
| 3.4 TEST ITEM AND TEST CONFIGURATION .....   | 10 |
| 3.5 EUT OPERATING CONDITIONS.....  | 11 |
| 3.6 GENERAL DESCRIPTION OF APPLIED STANDARDS .....   | 11 |
| 4 TEST TYPES AND RESULTS.....  | 12 |
| 4.1 RADIATED EMISSION MEASUREMENT.....   | 12 |
| 4.1.1 LIMITS OF RADIATED EMISSION MEASUREMENT .....  | 12 |
| 4.1.2 TEST PROCEDURES.....   | 12 |
| 4.1.3 DEVIATION FROM TEST STANDARD .....   | 12 |
| 4.1.4 TEST SETUP .....   | 13 |
| 4.1.5 TEST RESULTS .....   | 14 |
| 5 PHOTOGRAPHS OF THE TEST CONFIGURATION .....  | 20 |
| 6 INFORMATION ON THE TESTING LABORATORIES .....  | 21 |
| 7 APPENDIX A – MODIFICATIONS RECORDERS FOR ENGINEERING CHANGES TO THE EUT<br>BY THE LAB..... | 22 |



A D T

## RELEASE CONTROL RECORD

| ISSUE NO.      | REASON FOR CHANGE | DATE ISSUED   |
|----------------|-------------------|---------------|
| RF130521C18H-1 | Original release  | Oct. 08, 2013 |



# 1 CERTIFICATION

**PRODUCT:** Computer

**MODEL:** PWS-770xxxxxxxxxxxxxxxxxxxx  
("x" can be 0-9 or A-Z or blank or any alphanumeric character for marketing purpose)

**BRAND:** **ADVANTECH**

**APPLICANT:** ADVANTECH CO., LTD

**TESTED:** Oct. 02, 2013

**TEST SAMPLE:** ENGINEERING SAMPLE

**STANDARDS:** FCC Part 24, Subpart E

This report is issued as a supplementary report of **RF130521C18** for adding external battery pack. This report shall be used combining with its original report.

**PREPARED BY :** Polly Chiu , **DATE :** Oct. 08, 2013  
Polly Chiu / Specialist

**APPROVED BY :** Anderson Chiu , **DATE :** Oct. 08, 2013  
Anderson Chiu / Senior Engineer

**NOTE:** The radiated spurious emission below 1GHz test was performed for the addendum. Refer to original report for the other test data.



A D T

## 2 SUMMARY OF TEST RESULTS

The EUT has been tested according to the following specifications:

| APPLIED STANDARD: FCC Part 24 & Part 2 |   |        |   |
|--|---|--------|---|
| STANDARD SECTION                       | TEST TYPE                               | RESULT | REMARK  |
| 2.1046<br>24.232                       | Equivalent isotropically radiated power | NA     | Refer to Note   |
| 2.1055<br>24.235                       | Frequency Stability                     | NA     | Refer to Note   |
| 2.1049<br>24.238(b)                    | Occupied Bandwidth                      | NA     | Refer to Note   |
| 24.238(b)                              | Band Edge Measurements                  | NA     | Refer to Note   |
| 2.1051<br>24.238                       | Conducted Spurious Emissions            | NA     | Refer to Note   |
| 2.1053<br>24.238                       | Radiated Spurious Emissions             | PASS   | Meet the requirement of limit. Minimum passing margin is -31.30dB at 198.78MHz. |

**NOTE:** The radiated spurious emission below 1GHz test was performed for the addendum. Refer to original report for the other test data.

### 2.1 MEASUREMENT UNCERTAINTY

Where relevant, the following measurement uncertainty levels have been estimated for tests performed on the EUT as specified in CISPR 16-4-2:

| MEASUREMENT        | FREQUENCY       | UNCERTAINTY |
|--------------------|-----------------|-------------|
| Radiated emissions | 30MHz ~ 200MHz  | 3.34 dB     |
|                    | 200MHz ~1000MHz | 3.35 dB     |

This uncertainty represents an expanded uncertainty expressed at approximately the 95% confidence level using a coverage factor of k=2.



## 2.2 TEST SITE AND INSTRUMENTS

| DESCRIPTION & MANUFACTURER              | MODEL NO.                    | SERIAL NO.       | DATE OF CALIBRATION | DUE DATE OF CALIBRATION |
|---|------------------------------|------------------|---------------------|-------------------------|
| Test Receiver<br>ROHDE & SCHWARZ        | ESI7                         | 838496/016       | Dec. 25, 2012       | Dec. 24, 2013           |
| Spectrum Analyzer<br>ROHDE & SCHWARZ    | FSP40                        | 100039           | Jan. 31, 2013       | Jan. 30, 2014           |
| BILOG Antenna<br>SCHWARZBECK            | VULB9168                     | 9168-160         | Mar. 20, 2013       | Mar. 19, 2014           |
| HORN Antenna<br>SCHWARZBECK             | 9120D                        | 209              | Sep. 12, 2013       | Sep. 11, 2014           |
| HORN Antenna<br>SCHWARZBECK             | BBHA 9170                    | 148              | Jul. 15, 2013       | Jul. 14, 2014           |
| Preamplifier<br>Agilent                 | 8447D                        | 2944A10633       | Oct. 25, 2012       | Oct. 24, 2013           |
| Preamplifier<br>Agilent                 | 8449B                        | 3008A01964       | Oct. 25, 2012       | Oct. 24, 2013           |
| RF signal cable<br>HUBER+SUHNNER        | SUCOFLEX 104                 | 250723/4         | Aug. 23, 2013       | Aug. 22, 2014           |
| RF signal cable<br>HUBER+SUHNNER        | SUCOFLEX 106                 | 12738/6+309224/4 | Aug. 23, 2013       | Aug. 22, 2014           |
| Software<br>BV ADT                      | ADT_Radiated_<br>V7.6.15.9.4 | NA               | NA                  | NA                      |
| Antenna Tower<br>inn-co GmbH            | MA 4000                      | 013303           | NA                  | NA                      |
| Antenna Tower Controller<br>inn-co GmbH | CO2000                       | 017303           | NA                  | NA                      |
| Turn Table<br>BV ADT                    | TT100                        | TT93021703       | NA                  | NA                      |
| Turn Table Controller<br>BV ADT         | SC100                        | SC93021703       | NA                  | NA                      |

- NOTE:**
1. The calibration interval of the above test instruments is 12 months and the calibrations are traceable to NML/ROC and NIST/USA.
  2. The test was performed in HwaYa Chamber 3.
  3. The horn antenna and HP preamplifier (model: 8449B) are used only for the measurement of emission frequency above 1GHz if tested.
  4. The FCC Site Registration No. is 988962.
  5. The IC Site Registration No. is IC 7450F-3.



### 3 GENERAL INFORMATION

#### 3.1 GENERAL DESCRIPTION OF EUT

|                          |   |
|--------------------------|---|
| <b>EUT</b>               | Computer  |
| <b>MODEL NO.</b>         | PWS-770xxxxxxxxxxxxxxxxxxx ("x" can be 0-9 or A-Z or blank or any alphanumeric character for marketing purpose) |
| <b>POWER SUPPLY</b>      | 19Vdc (Adapter or cradle)<br>11.1Vdc (Battery)  |
| <b>MODULATION TYPE</b>   | <b>GSM, GPRS, EDGE:</b> GMSK<br><b>WCDMA, HSDPA, HSUPA:</b> BPSK  |
| <b>FREQUENCY RANGE</b>   | <b>GSM, GPRS, EDGE:</b> 1850.2MHz ~ 1909.8MHz<br><b>WCDMA, HSDPA, HSUPA:</b> 1852.4MHz ~ 1907.6MHz              |
| <b>MAX. EIRP POWER</b>   | <b>GSM:</b> 497.74mW (26.97dBm)<br><b>WCDMA:</b> 91.83mW (19.63dBm)   |
| <b>ANTENNA TYPE</b>      | PIFA antenna with -3.05dBi gain   |
| <b>ANTENNA CONNECTOR</b> | IPEX  |
| <b>I/O PORTS</b>         | Refer to users' manual  |
| <b>DATA CABLE</b>        | NA  |
| <b>ACCESSORY DEVICES</b> | Adapter, Cradle, Stylus, Battery  |

**NOTE:**

1. This is a supplementary report of RF130521C18-1. This report shall be combined together with its original report.
2. This report is prepared for FCC class II permissive change. Difference compared with the original report is adding external battery pack. Therefore, the radiated spurious emission below 1GHz test had been re-tested and presented in the test report.
3. All models are electrically identical, different model names are for marketing purpose. Model PWS-770 is the representative for final test.

| Brand     | Model   |
|-----------|---|
| Advantech | PWS-770xxxxxxxxxxxxxxxxxxx ("x" can be 0-9 or A-Z or blank or any alphanumeric character for marketing purpose) |

4. The EUT contains the following accessories. (New External Battery Pack is marked in boldface.)

| No. | Product                      | Brand                         | Model                  | Description   |
|-----|------------------------------|-------------------------------|------------------------|---|
| 1   | Adapter                      | FSP GROUP INC.                | FSP065-RAB             | Input: 100-240Vac, 1.5A, 50-60Hz<br>Output: 19Vdc, 3.42A<br>Power Line:<br>1.5m cable with 1 core attached on adapter |
| 2   | Battery Pack                 | Joules                        | 1760001576             | Rating: 11.1Vdc, 1880mA, 20.87Wh<br>Type: Li-ion  |
| 3   | Cradle 1                     | ADVANTECH                     | pws-770 cradle         | Rating: 19Vdc, 3.42A  |
| 4   | Cradle 2                     | ADVANTECH                     | pws-770 vehicle cradle | Rating: 18.5Vdc, 4.9A   |
| 5   | <b>External Battery Pack</b> | <b>JOULES MILES CO., LTD.</b> | <b>PWS-770-01</b>      | <b>Rating: 11.1Vdc, 5000mA, 55.5Wh</b>  |

5. HW version is PCB PWS-770 MB A101-4
6. SW version is Image WIN7 pro PWS-770 V1.0 ENG
7. The above EUT information is declared by manufacturer and for more detailed feature description, please refer to the manufacturer's specifications or User's Manual.

### 3.2 CONFIGURATION OF SYSTEM UNDER TEST

#### TEST MODE A, B

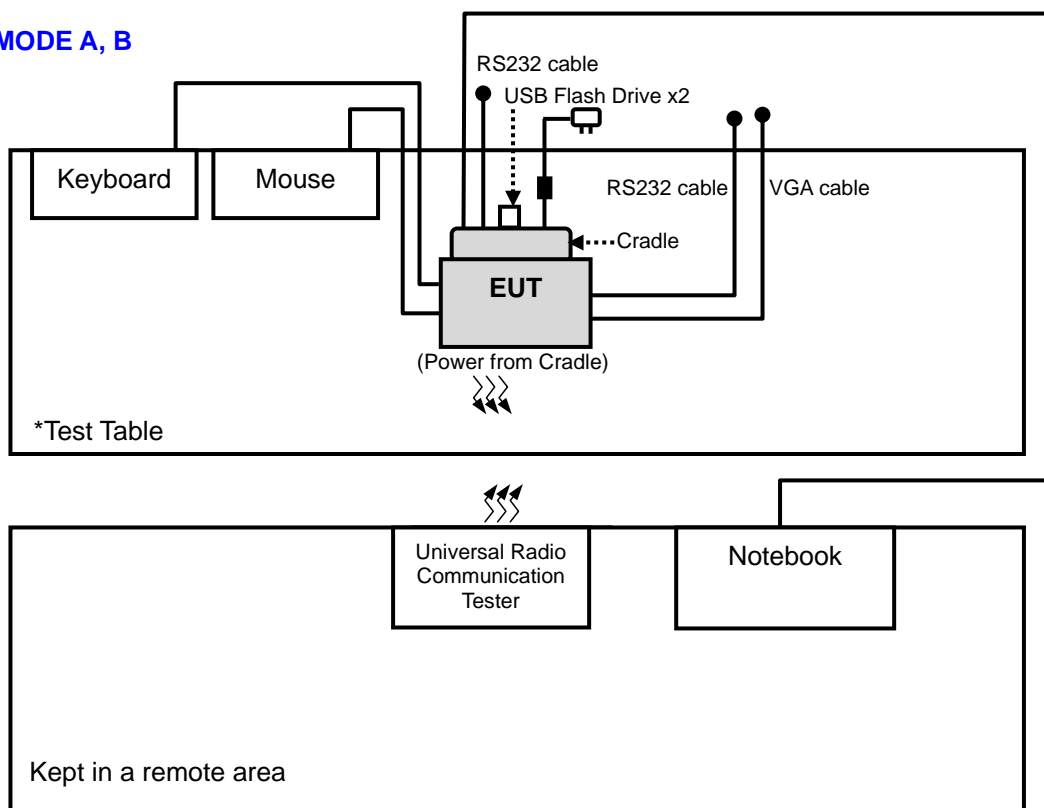

#### TEST MODE C

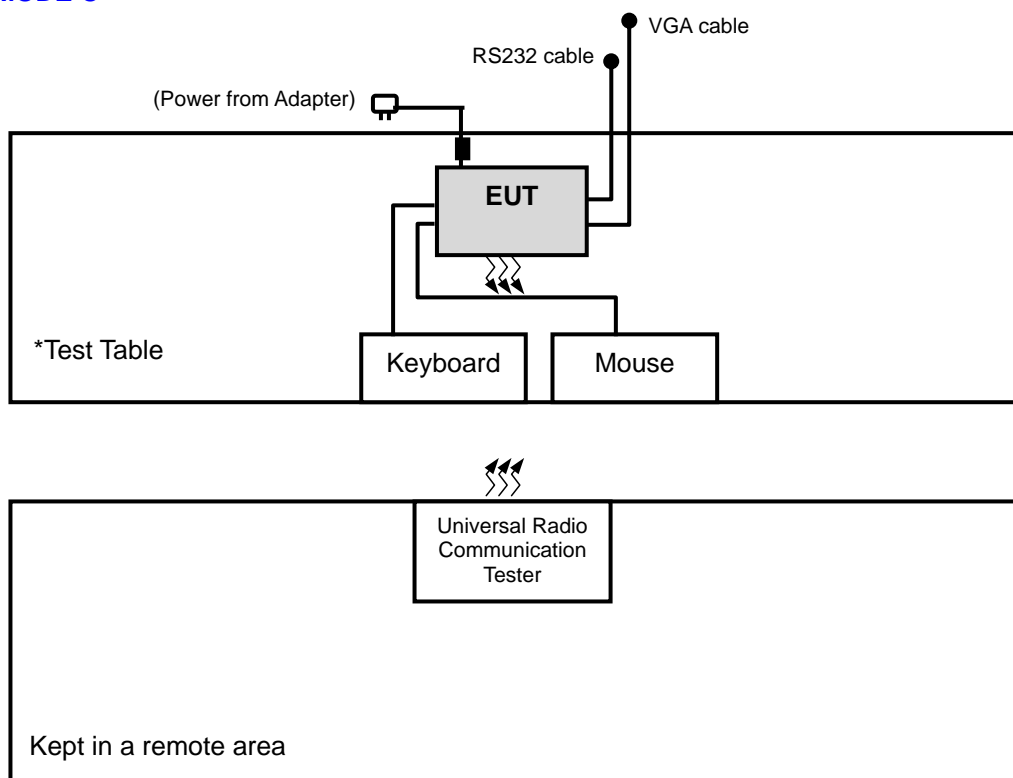



### 3.3 DESCRIPTION OF SUPPORT UNITS

The EUT has been tested as an independent unit together with other necessary accessories or support units. The following support units or accessories were used to form a representative test configuration during the tests.

| NO. | PRODUCT                              | BRAND     | MODEL NO. | SERIAL NO.                   | FCC ID           |
|-----|--------------------------------------|-----------|-----------|------------------------------|------------------|
| 1   | KEYBOARD                             | DELL      | KB4021    | CN-05V23T-71581-1AK-01Q2-A01 | FCC DoC Approved |
| 2   | MOUSE                                | DELL      | MS111-P   | CN-011D3V-71581-1CJ-019E     | FCC DoC Approved |
| 3   | USB FLASH DRIVE                      | Transcend | V85       | 538455 4490                  | NA               |
| 4   | USB FLASH DRIVE                      | Transcend | V85       | 538455 4489                  | NA               |
| 5   | NOTEBOOK                             | DELL      | E5410     | 6RP2YM1                      | FCC DoC Approved |
| 6   | UNIVERSAL RADIO COMMUNICATION TESTER | R&S       | CMU200    | 123112                       | NA               |

| NO. | SIGNAL CABLE DESCRIPTION OF THE ABOVE SUPPORT UNITS |
|-----|---|
| 1   | 1.8m foil shielded wire, USB connector, w/o core    |
| 2   | 1.8m foil shielded wire, USB connector, w/o core    |
| 3   | NA  |
| 4   | NA  |
| 5   | 10m RJ45cable, w/o core                             |
| 6   | NA  |

**NOTE:**

1. All power cords of the above support units are non shielded (1.8m).
2. Item 5-6 acted as communication partners to transfer data.

### 3.4 TEST ITEM AND TEST CONFIGURATION

Pre-Scan has been conducted to determine the worst-case mode from all possible combinations between available modulations, data rates, XYZ axis and antenna ports. The worst case was found when positioned on Z-plane. Following channel(s) was (were) selected for the final test as listed below:

Test results are presented in the report as below.

| Test Mode | Test Condition  |
|-----------|---|
| A         | EUT with external battery pack, power from cradle 1                 |
| B         | EUT with external battery pack, power from cradle 2                 |
| C         | EUT with external battery pack, power from adapter (without cradle) |

#### GSM MODE

| EUT CONFIGURE MODE | TEST ITEM                        | AVAILABLE CHANNEL | TESTED CHANNEL | MODE |
|--------------------|----------------------------------|-------------------|----------------|------|
| A, B, C            | RADIATED EMISSION<br>BELOW 1 GHz | 512 to 810        | 661            | GSM  |

#### WCDMA MODE

| EUT CONFIGURE MODE | TEST ITEM                        | AVAILABLE CHANNEL | TESTED CHANNEL | MODE  |
|--------------------|----------------------------------|-------------------|----------------|-------|
| A, B, C            | RADIATED EMISSION<br>BELOW 1 GHz | 9262 to 9538      | 9400           | WCDMA |

#### TEST CONDITION:

| TEST ITEM                       | ENVIRONMENTAL CONDITIONS | INPUT POWER  | TESTED BY |
|---------------------------------|--------------------------|--------------|-----------|
| RADIATED EMISSION<br>BELOW 1GHz | 25deg. C, 65%RH          | 120Vac, 60Hz | Brad Tung |

### **3.5 EUT OPERATING CONDITIONS**

The EUT makes a call to the communication simulator. The communication simulator station system controlled a EUT to export maximum output power under transmission mode and specific channel frequency

### **3.6 GENERAL DESCRIPTION OF APPLIED STANDARDS**

The EUT is a RF product. According to the specifications of the manufacturer, it must comply with the requirements of the following standards:

**FCC 47 CFR Part 2**

**FCC 47 CFR Part 24**

**ANSI/TIA/EIA-603-C 2004**

**NOTE:** All test items have been performed and recorded as per the above standards.

## 4 TEST TYPES AND RESULTS

### 4.1 RADIATED EMISSION MEASUREMENT

#### 4.1.1 LIMITS OF RADIATED EMISSION MEASUREMENT

The power of any emission outside of the authorized operating frequency ranges must be attenuated below the transmitting power (P) by a factor of at least  $43 + 10 \log(P)$  dB. The emission limit equal to  $-13\text{dBm}$ .

#### 4.1.2 TEST PROCEDURES

- a. Substitution method is used for E.I.R.P measurement. In the semi-anechoic chamber, EUT placed on the 0.8m height of Turn Table, rotated the table around 360 degrees to search the maximum radiation power and receiver antenna shall be rotated vertical and horizontal polarization and moved height from 1m to 4m to find the maximum polar radiated power. The “Read Value” is the spectrum reading the maximum power value.
- b. The substitution horn antenna is substituted for EUT at the same position and signals generator export the CW signal to the substitution antenna via a TX cable. Rotated the Turn Table and moved receiving antenna to find the maximum radiation power. Adjust output power level of S.G to get a Value of spectrum reading equal to “Read Value” of step a. Record the power level of S.G
- c.  $\text{EIRP} = \text{Output power level of S.G} - \text{TX cable loss} + \text{Antenna gain of substitution horn}$ .
- d. E.R.P power can be calculated form E.I.R.P power by subtracting the gain of dipole,  $\text{E.R.P power} = \text{E.I.R.P power} - 2.15\text{dBi}$ .

**NOTE:** The resolution bandwidth and video bandwidth of test receiver/spectrum analyzer is 1MHz/3MHz.

#### 4.1.3 DEVIATION FROM TEST STANDARD

No deviation

#### 4.1.4 TEST SETUP

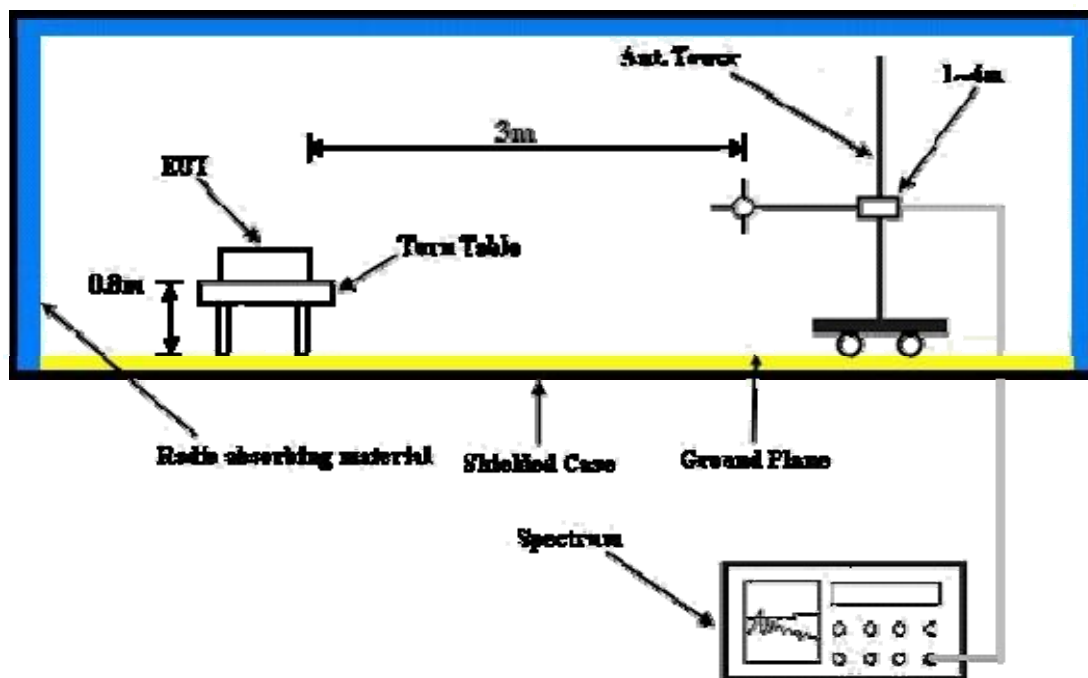

For the actual test configuration, please refer to the attached file (Test Setup Photo).



A D T

#### 4.1.5 TEST RESULTS

##### GSM

|                                 |                 |                        |               |
|---------------------------------|-----------------|------------------------|---------------|
| <b>MODE</b>                     | TX channel 661  | <b>FREQUENCY RANGE</b> | Below 1000MHz |
| <b>ENVIRONMENTAL CONDITIONS</b> | 25deg. C, 65%RH | <b>INPUT POWER</b>     | 120Vac, 60 Hz |
| <b>TESTED BY</b>                | Brad Tung       | <b>TEST MODE</b>       | A             |

| ANTENNA POLARITY & TEST DISTANCE: HORIZONTAL AT 3 M |             |               |                       |                        |            |             |             |
|---|-------------|---------------|-----------------------|------------------------|------------|-------------|-------------|
| No.   | Freq. (MHz) | Reading (dBm) | S.G Power Value (dBm) | Correction Factor (dB) | EIRP (dBm) | Limit (dBm) | Margin (dB) |
| 1   | 198.78      | -45.40        | -49.70                | 5.40                   | -44.30     | -13.00      | -31.30      |
| 2   | 220.12      | -50.60        | -54.90                | 5.40                   | -49.50     | -13.00      | -36.50      |
| 3   | 398.60      | -55.20        | -59.30                | 5.20                   | -54.10     | -13.00      | -41.10      |
| 4   | 497.54      | -59.40        | -63.20                | 4.90                   | -58.30     | -13.00      | -45.30      |
| 5   | 701.24      | -55.60        | -59.70                | 5.20                   | -54.50     | -13.00      | -41.50      |
| 6   | 800.18      | -57.80        | -60.70                | 4.00                   | -56.70     | -13.00      | -43.70      |

| ANTENNA POLARITY & TEST DISTANCE: VERTICAL AT 3 M |             |               |                       |                        |            |             |             |
|---|-------------|---------------|-----------------------|------------------------|------------|-------------|-------------|
| No.   | Freq. (MHz) | Reading (dBm) | S.G Power Value (dBm) | Correction Factor (dB) | EIRP (dBm) | Limit (dBm) | Margin (dB) |
| 1   | 107.60      | -44.60        | -49.10                | 0.50                   | -48.60     | -13.00      | -35.60      |
| 2   | 165.80      | -56.10        | -55.80                | 1.20                   | -54.60     | -13.00      | -41.60      |
| 3   | 198.78      | -44.90        | -52.70                | 5.40                   | -47.30     | -13.00      | -34.30      |
| 4   | 398.60      | -58.80        | -62.10                | 5.20                   | -56.90     | -13.00      | -43.90      |
| 5   | 499.48      | -57.30        | -59.50                | 4.90                   | -54.60     | -13.00      | -41.60      |
| 6   | 699.30      | -63.60        | -61.20                | 5.30                   | -55.90     | -13.00      | -42.90      |

##### REMARKS:

1. Power Value (dBm) = S.G Power Value (dBm) + Correction Factor (dB).
2. Correction Factor (dB) = Substitution Antenna Gain (dB) + Cable Loss (dB).



A D T

|                                 |                 |                        |               |
|---------------------------------|-----------------|------------------------|---------------|
| <b>MODE</b>                     | TX channel 661  | <b>FREQUENCY RANGE</b> | Below 1000MHz |
| <b>ENVIRONMENTAL CONDITIONS</b> | 25deg. C, 65%RH | <b>INPUT POWER</b>     | 120Vac, 60 Hz |
| <b>TESTED BY</b>                | Brad Tung       | <b>TEST MODE</b>       | B             |

| <b>ANTENNA POLARITY &amp; TEST DISTANCE: HORIZONTAL AT 3 M</b> |             |               |                       |                        |            |             |             |
|--|-------------|---------------|-----------------------|------------------------|------------|-------------|-------------|
| No.  | Freq. (MHz) | Reading (dBm) | S.G Power Value (dBm) | Correction Factor (dB) | EIRP (dBm) | Limit (dBm) | Margin (dB) |
| 1  | 198.78      | -46.00        | -50.30                | 5.40                   | -44.90     | -13.00      | -31.90      |
| 2  | 222.06      | -50.50        | -54.80                | 5.40                   | -49.40     | -13.00      | -36.40      |
| 3  | 398.60      | -56.50        | -60.60                | 5.20                   | -55.40     | -13.00      | -42.40      |
| 4  | 497.54      | -60.20        | -64.00                | 4.90                   | -59.10     | -13.00      | -46.10      |
| 5  | 697.36      | -55.00        | -59.20                | 5.30                   | -53.90     | -13.00      | -40.90      |
| 6  | 798.24      | -57.20        | -60.10                | 4.00                   | -56.10     | -13.00      | -43.10      |
| <b>ANTENNA POLARITY &amp; TEST DISTANCE: VERTICAL AT 3 M</b>   |             |               |                       |                        |            |             |             |
| No.  | Freq. (MHz) | Reading (dBm) | S.G Power Value (dBm) | Correction Factor (dB) | EIRP (dBm) | Limit (dBm) | Margin (dB) |
| 1  | 105.66      | -43.90        | -48.50                | 0.60                   | -47.90     | -13.00      | -34.90      |
| 2  | 169.68      | -57.00        | -56.70                | 1.60                   | -55.10     | -13.00      | -42.10      |
| 3  | 198.78      | -44.50        | -52.30                | 5.40                   | -46.90     | -13.00      | -33.90      |
| 4  | 400.54      | -59.00        | -62.30                | 5.20                   | -57.10     | -13.00      | -44.10      |
| 5  | 497.54      | -57.20        | -59.40                | 4.90                   | -54.50     | -13.00      | -41.50      |
| 6  | 699.30      | -62.80        | -60.40                | 5.30                   | -55.10     | -13.00      | -42.10      |

**REMARKS:**

1. Power Value (dBm) = S.G Power Value (dBm) + Correction Factor (dB).
2. Correction Factor (dB) = Substitution Antenna Gain (dB) + Cable Loss (dB).



A D T

|                                 |                 |                        |               |
|---------------------------------|-----------------|------------------------|---------------|
| <b>MODE</b>                     | TX channel 661  | <b>FREQUENCY RANGE</b> | Below 1000MHz |
| <b>ENVIRONMENTAL CONDITIONS</b> | 25deg. C, 65%RH | <b>INPUT POWER</b>     | 120Vac, 60 Hz |
| <b>TESTED BY</b>                | Brad Tung       | <b>TEST MODE</b>       | C             |

| <b>ANTENNA POLARITY &amp; TEST DISTANCE: HORIZONTAL AT 3 M</b> |             |               |                       |                        |            |             |             |
|--|-------------|---------------|-----------------------|------------------------|------------|-------------|-------------|
| No.  | Freq. (MHz) | Reading (dBm) | S.G Power Value (dBm) | Correction Factor (dB) | EIRP (dBm) | Limit (dBm) | Margin (dB) |
| 1  | 198.78      | -45.90        | -50.20                | 5.40                   | -44.80     | -13.00      | -31.80      |
| 2  | 224.00      | -51.10        | -55.40                | 5.40                   | -50.00     | -13.00      | -37.00      |
| 3  | 398.60      | -55.80        | -59.90                | 5.20                   | -54.70     | -13.00      | -41.70      |
| 4  | 497.54      | -58.70        | -62.50                | 4.90                   | -57.60     | -13.00      | -44.60      |
| 5  | 699.30      | -55.60        | -59.80                | 5.30                   | -54.50     | -13.00      | -41.50      |
| 6  | 798.24      | -57.10        | -60.00                | 4.00                   | -56.00     | -13.00      | -43.00      |
| <b>ANTENNA POLARITY &amp; TEST DISTANCE: VERTICAL AT 3 M</b>   |             |               |                       |                        |            |             |             |
| No.  | Freq. (MHz) | Reading (dBm) | S.G Power Value (dBm) | Correction Factor (dB) | EIRP (dBm) | Limit (dBm) | Margin (dB) |
| 1  | 61.04       | -48.50        | -47.20                | -7.30                  | -54.50     | -13.00      | -41.50      |
| 2  | 105.66      | -44.00        | -48.60                | 0.60                   | -48.00     | -13.00      | -35.00      |
| 3  | 198.78      | -44.60        | -52.40                | 5.40                   | -47.00     | -13.00      | -34.00      |
| 4  | 398.60      | -58.20        | -61.50                | 5.20                   | -56.30     | -13.00      | -43.30      |
| 5  | 497.54      | -56.30        | -58.50                | 4.90                   | -53.60     | -13.00      | -40.60      |
| 6  | 699.30      | -62.80        | -60.40                | 5.30                   | -55.10     | -13.00      | -42.10      |

**REMARKS:**

1. Power Value (dBm) = S.G Power Value (dBm) + Correction Factor (dB).
2. Correction Factor (dB) = Substitution Antenna Gain (dB) + Cable Loss (dB).





A D T

**WCDMA**

|                                 |                 |                        |               |
|---------------------------------|-----------------|------------------------|---------------|
| <b>MODE</b>                     | TX channel 9400 | <b>FREQUENCY RANGE</b> | Below 1000MHz |
| <b>ENVIRONMENTAL CONDITIONS</b> | 25deg. C, 65%RH | <b>INPUT POWER</b>     | 120Vac, 60 Hz |
| <b>TESTED BY</b>                | Brad Tung       | <b>TEST MODE</b>       | A             |

**ANTENNA POLARITY & TEST DISTANCE: HORIZONTAL AT 3 M**

| No. | Freq. (MHz) | Reading (dBm) | S.G Power Value (dBm) | Correction Factor (dB) | EIRP (dBm) | Limit (dBm) | Margin (dB) |
|-----|-------------|---------------|-----------------------|------------------------|------------|-------------|-------------|
| 1   | 198.78      | -46.20        | -50.50                | 5.40                   | -45.10     | -13.00      | -32.10      |
| 2   | 222.06      | -51.20        | -55.50                | 5.40                   | -50.10     | -13.00      | -37.10      |
| 3   | 398.60      | -56.40        | -60.50                | 5.20                   | -55.30     | -13.00      | -42.30      |
| 4   | 499.48      | -59.10        | -62.90                | 4.90                   | -58.00     | -13.00      | -45.00      |
| 5   | 697.36      | -55.70        | -59.90                | 5.30                   | -54.60     | -13.00      | -41.60      |
| 6   | 798.24      | -57.60        | -60.50                | 4.00                   | -56.50     | -13.00      | -43.50      |

**ANTENNA POLARITY & TEST DISTANCE: VERTICAL AT 3 M**

| No. | Freq. (MHz) | Reading (dBm) | S.G Power Value (dBm) | Correction Factor (dB) | EIRP (dBm) | Limit (dBm) | Margin (dB) |
|-----|-------------|---------------|-----------------------|------------------------|------------|-------------|-------------|
| 1   | 107.60      | -44.80        | -49.30                | 0.50                   | -48.80     | -13.00      | -35.80      |
| 2   | 165.80      | -55.30        | -55.00                | 1.20                   | -53.80     | -13.00      | -40.80      |
| 3   | 198.78      | -44.70        | -52.50                | 5.40                   | -47.10     | -13.00      | -34.10      |
| 4   | 398.60      | -58.80        | -62.10                | 5.20                   | -56.90     | -13.00      | -43.90      |
| 5   | 499.48      | -57.00        | -59.20                | 4.90                   | -54.30     | -13.00      | -41.30      |
| 6   | 697.36      | -62.60        | -60.20                | 5.30                   | -54.90     | -13.00      | -41.90      |

**REMARKS:**

1. Power Value (dBm) = S.G Power Value (dBm) + Correction Factor (dB).
2. Correction Factor (dB) = Substitution Antenna Gain (dB) + Cable Loss (dB).



A D T

|                                 |                 |                        |               |
|---------------------------------|-----------------|------------------------|---------------|
| <b>MODE</b>                     | TX channel 9400 | <b>FREQUENCY RANGE</b> | Below 1000MHz |
| <b>ENVIRONMENTAL CONDITIONS</b> | 25deg. C, 65%RH | <b>INPUT POWER</b>     | 120Vac, 60 Hz |
| <b>TESTED BY</b>                | Brad Tung       | <b>TEST MODE</b>       | B             |

| <b>ANTENNA POLARITY &amp; TEST DISTANCE: HORIZONTAL AT 3 M</b> |             |               |                       |                        |            |             |             |
|--|-------------|---------------|-----------------------|------------------------|------------|-------------|-------------|
| No.  | Freq. (MHz) | Reading (dBm) | S.G Power Value (dBm) | Correction Factor (dB) | EIRP (dBm) | Limit (dBm) | Margin (dB) |
| 1  | 198.78      | -45.70        | -50.00                | 5.40                   | -44.60     | -13.00      | -31.60      |
| 2  | 225.94      | -51.60        | -55.90                | 5.40                   | -50.50     | -13.00      | -37.50      |
| 3  | 398.60      | -56.20        | -60.30                | 5.20                   | -55.10     | -13.00      | -42.10      |
| 4  | 497.54      | -59.60        | -63.40                | 4.90                   | -58.50     | -13.00      | -45.50      |
| 5  | 699.30      | -55.50        | -59.70                | 5.30                   | -54.40     | -13.00      | -41.40      |
| 6  | 796.30      | -57.40        | -60.40                | 4.10                   | -56.30     | -13.00      | -43.30      |
| <b>ANTENNA POLARITY &amp; TEST DISTANCE: VERTICAL AT 3 M</b>   |             |               |                       |                        |            |             |             |
| No.  | Freq. (MHz) | Reading (dBm) | S.G Power Value (dBm) | Correction Factor (dB) | EIRP (dBm) | Limit (dBm) | Margin (dB) |
| 1  | 107.60      | -44.20        | -48.70                | 0.50                   | -48.20     | -13.00      | -35.20      |
| 2  | 163.86      | -56.20        | -55.80                | 0.90                   | -54.90     | -13.00      | -41.90      |
| 3  | 198.78      | -44.20        | -52.00                | 5.40                   | -46.60     | -13.00      | -33.60      |
| 4  | 398.60      | -59.20        | -62.50                | 5.20                   | -57.30     | -13.00      | -44.30      |
| 5  | 497.54      | -57.90        | -60.10                | 4.90                   | -55.20     | -13.00      | -42.20      |
| 6  | 699.30      | -62.90        | -60.50                | 5.30                   | -55.20     | -13.00      | -42.20      |

**REMARKS:**

1. Power Value (dBm) = S.G Power Value (dBm) + Correction Factor (dB).
2. Correction Factor (dB) = Substitution Antenna Gain (dB) + Cable Loss (dB).



A D T

|                                 |                 |                        |               |
|---------------------------------|-----------------|------------------------|---------------|
| <b>MODE</b>                     | TX channel 9400 | <b>FREQUENCY RANGE</b> | Below 1000MHz |
| <b>ENVIRONMENTAL CONDITIONS</b> | 25deg. C, 65%RH | <b>INPUT POWER</b>     | 120Vac, 60 Hz |
| <b>TESTED BY</b>                | Brad Tung       | <b>TEST MODE</b>       | C             |

| <b>ANTENNA POLARITY &amp; TEST DISTANCE: HORIZONTAL AT 3 M</b> |             |               |                       |                        |            |             |             |
|--|-------------|---------------|-----------------------|------------------------|------------|-------------|-------------|
| No.  | Freq. (MHz) | Reading (dBm) | S.G Power Value (dBm) | Correction Factor (dB) | EIRP (dBm) | Limit (dBm) | Margin (dB) |
| 1  | 198.78      | -45.90        | -50.20                | 5.40                   | -44.80     | -13.00      | -31.80      |
| 2  | 222.06      | -51.50        | -55.80                | 5.40                   | -50.40     | -13.00      | -37.40      |
| 3  | 398.60      | -56.20        | -60.30                | 5.20                   | -55.10     | -13.00      | -42.10      |
| 4  | 497.54      | -60.30        | -64.10                | 4.90                   | -59.20     | -13.00      | -46.20      |
| 5  | 699.30      | -55.60        | -59.80                | 5.30                   | -54.50     | -13.00      | -41.50      |
| 6  | 798.24      | -57.40        | -60.30                | 4.00                   | -56.30     | -13.00      | -43.30      |

| <b>ANTENNA POLARITY &amp; TEST DISTANCE: VERTICAL AT 3 M</b> |             |               |                       |                        |            |             |             |
|--|-------------|---------------|-----------------------|------------------------|------------|-------------|-------------|
| No.  | Freq. (MHz) | Reading (dBm) | S.G Power Value (dBm) | Correction Factor (dB) | EIRP (dBm) | Limit (dBm) | Margin (dB) |
| 1  | 107.60      | -44.70        | -49.20                | 0.50                   | -48.70     | -13.00      | -35.70      |
| 2  | 163.86      | -55.30        | -54.90                | 0.90                   | -54.00     | -13.00      | -41.00      |
| 3  | 198.78      | -45.10        | -52.90                | 5.40                   | -47.50     | -13.00      | -34.50      |
| 4  | 398.60      | -58.60        | -61.90                | 5.20                   | -56.70     | -13.00      | -43.70      |
| 5  | 499.48      | -56.30        | -58.50                | 4.90                   | -53.60     | -13.00      | -40.60      |
| 6  | 697.36      | -62.80        | -60.40                | 5.30                   | -55.10     | -13.00      | -42.10      |

**REMARKS:**

1. Power Value (dBm) = S.G Power Value (dBm) + Correction Factor (dB).
2. Correction Factor (dB) = Substitution Antenna Gain (dB) + Cable Loss (dB).



## 5 PHOTOGRAPHS OF THE TEST CONFIGURATION

Please refer to the attached file (Test Setup Photo).



## 6 INFORMATION ON THE TESTING LABORATORIES

We, Bureau Veritas Consumer Products Services (H.K.) Ltd., Taoyuan Branch, were founded in 1988 to provide our best service in EMC, Radio, Telecom and Safety consultation. Our laboratories are accredited and approved according to ISO/IEC 17025.

If you have any comments, please feel free to contact us at the following:

**Linko EMC/RF Lab:**

Tel: 886-2-26052180

Fax: 886-2-26051924

**Hsin Chu EMC/RF Lab:**

Tel: 886-3-5935343

Fax: 886-3-5935342

**Hwa Ya EMC/RF/Safety/Telecom Lab:**

Tel: 886-3-3183232

Fax: 886-3-3270892

**Email:** [service.adt@tw.bureauveritas.com](mailto:service.adt@tw.bureauveritas.com)

**Web Site:** [www.bureauveritas-adt.com](http://www.bureauveritas-adt.com)

The address and road map of all our labs can be found in our web site also.



A D T

## **7 APPENDIX A – MODIFICATIONS RECORDERS FOR ENGINEERING CHANGES TO THE EUT BY THE LAB**

No any modifications are made to the EUT by the lab during the test.

---END---