



FCC TEST REPORT (WLAN)

REPORT NO.: RF130521C18H-2

MODEL NO.: PWS-770xxxxxxxxxxxxxxxxxxx ("x" can be 0-9 or A-Z or blank or any alphanumeric character for marketing purpose)

FCC ID: M82-PWS-770PH

RECEIVED: Oct. 01, 2013

TESTED: Oct. 01 ~ Oct. 03, 2013

ISSUED: Oct. 08, 2013

APPLICANT: ADVANTECH CO., LTD

ADDRESS: No. 1, Alley 20, Lane 26, Rueiguang Rd, Neihu District, Taipei, Taiwan 114

ISSUED BY: Bureau Veritas Consumer Products Services (H.K.) Ltd., Taoyuan Branch

LAB ADDRESS: No. 47, 14th Ling, Chia Pau Vil., Lin Kou Dist., New Taipei City, Taiwan, R.O.C.

TEST LOCATION: No. 19, Hwa Ya 2nd Rd, Wen Hwa Tsuen, Kwei Shan Hsiang, Taoyuan Hsien 333, Taiwan, R.O.C.

This report should not be used by the client to claim product certification, approval, or endorsement by TAF or any government agencies.



This report is for your exclusive use. Any copying or replication of this report to or for any other person or entity, or use of our name or trademark, is permitted only with our prior written permission. This report sets forth our findings solely with respect to the test samples identified herein. The results set forth in this report are not indicative or representative of the quality or characteristics of the lot from which a test sample was taken or any similar or identical product unless specifically and expressly noted. Our report includes all of the tests requested by you and the results thereof based upon the information that you provided to us. You have 60 days from date of issuance of this report to notify us of any material error or omission caused by our negligence, provided, however, that such notice shall be in writing and shall specifically address the issue you wish to raise. A failure to raise such issue within the prescribed time shall constitute your unqualified acceptance of the completeness of this report, the tests conducted and the correctness of the report contents. Unless specific mention, the uncertainty of measurement has been explicitly taken into account to declare the compliance or non-compliance to the specification.



A D T

TABLE OF CONTENTS

RELEASE CONTROL RECORD	3
1. CERTIFICATION.....	4
2. SUMMARY OF TEST RESULTS	5
2.1 MEASUREMENT UNCERTAINTY	5
3. GENERAL INFORMATION.....	6
3.1 GENERAL DESCRIPTION OF EUT.....	6
3.2 DESCRIPTION OF TEST MODES.....	8
3.2.1 TEST MODE APPLICABILITY AND TESTED CHANNEL DETAIL.....	9
3.3 DESCRIPTION OF SUPPORT UNITS	10
3.3.1 CONFIGURATION OF SYSTEM UNDER TEST	11
3.4 GENERAL DESCRIPTION OF APPLIED STANDARDS.....	12
4. TEST TYPES AND RESULTS	13
4.1 RADIATED EMISSION AND BANDEDGE MEASUREMENT	13
4.1.1 LIMITS OF RADIATED EMISSION AND BANDEDGE MEASUREMENT.....	13
4.1.2 TEST INSTRUMENTS.....	14
4.1.3 TEST PROCEDURES	15
4.1.4 DEVIATION FROM TEST STANDARD	15
4.1.5 TEST SETUP	16
4.1.6 EUT OPERATING CONDITIONS.....	16
4.1.7 TEST RESULTS	17
4.2 CONDUCTED EMISSION MEASUREMENT	20
4.2.1 LIMITS OF CONDUCTED EMISSION MEASUREMENT	20
4.2.2 TEST INSTRUMENTS.....	20
4.2.3 TEST PROCEDURES	21
4.2.4 DEVIATION FROM TEST STANDARD	21
4.2.5 TEST SETUP	21
4.2.6 EUT OPERATING CONDITIONS.....	21
4.2.7 TEST RESULTS	22
5. PHOTOGRAPHS OF THE TEST CONFIGURATION	28
6. INFORMATION ON THE TESTING LABORATORIES.....	29
7. APPENDIX A - MODIFICATIONS RECORDERS FOR ENGINEERING CHANGES TO THE EUT BY THE LAB	30



A D T

RELEASE CONTROL RECORD

ISSUE NO.	REASON FOR CHANGE	DATE ISSUED
RF130521C18H-2	Original release	Oct. 08, 2013



1. CERTIFICATION

PRODUCT: Computer

MODEL NO.: PWS-770xxxxxxxxxxxxxxxxxxxxx ("x" can be 0-9 or A-Z or blank or any alphanumeric character for marketing purpose)

BRAND: **ADVANTECH**

APPLICANT: ADVANTECH CO., LTD

TESTED: Oct. 01 ~ Oct. 03, 2013

TEST SAMPLE: ENGINEERING SAMPLE

STANDARDS: **FCC Part 15, Subpart C (Section 15.247)**
ANSI C63.10-2009

This report is issued as a supplementary report of **RF130521C18-2** for adding external battery pack. This report shall be used combining with its original report.

PREPARED BY : Polly Chien , **DATE :** Oct. 08, 2013
Polly Chien / Specialist

APPROVED BY : Ken Liu , **DATE :** Oct. 08, 2013
Ken Liu / Senior Manager

NOTE: The conducted emission and radiated emission below 1GHz tests were performed for the addendum. Refer to original report for the other test data.



2. SUMMARY OF TEST RESULTS

The EUT has been tested according to the following specifications:

APPLIED STANDARD: FCC PART 15, SUBPART C (SECTION 15.247)			
STANDARD SECTION	TEST TYPE	RESULT	REMARK
15.207	AC Power Conducted Emission	PASS	Meet the requirement of limit. Minimum passing margin is -12.64dB at 0.82969MHz.
15.247(d) 15.209	Radiated Emissions	PASS	Meet the requirement of limit. Minimum passing margin is -6.5dB at 198.71MHz.
15.247(d)	Band Edge Measurement	NA	Refer to Note
15.247(a)(2)	6dB bandwidth	NA	Refer to Note
15.247(b)	Conducted power	NA	Refer to Note
15.247(e)	Power Spectral Density	NA	Refer to Note
15.203	Antenna Requirement	NA	Refer to Note

NOTE: The conducted emission and radiated emission below 1GHz tests were performed for the addendum. Refer to original report for the other test data.

2.1 MEASUREMENT UNCERTAINTY

Where relevant, the following measurement uncertainty levels have been estimated for tests performed on the EUT as specified in CISPR 16-4-2:

MEASUREMENT	FREQUENCY	UNCERTAINTY
Conducted emissions	150kHz~30MHz	2.44 dB
Radiated emissions	30MHz ~ 200MHz	3.34 dB
	200MHz ~1000MHz	3.35 dB

This uncertainty represents an expanded uncertainty expressed at approximately the 95% confidence level using a coverage factor of $k = 2$.



3. GENERAL INFORMATION

3.1 GENERAL DESCRIPTION OF EUT

EUT	Computer
MODEL NO.	PWS-770xxxxxxxxxxxxxxxxxx (“x” can be 0-9 or A-Z or blank or any alphanumeric character for marketing purpose)
POWER SUPPLY	19Vdc (Adapter) 11.1Vdc (Battery)
MODULATION TYPE	CCK, DQPSK, DBPSK for DSSS 64QAM, 16QAM, QPSK, BPSK for OFDM
MODULATION TECHNOLOGY	DSSS, OFDM
TRANSFER RATE	802.11b:11.0/ 5.5/ 2.0/ 1.0Mbps 802.11g: 54.0/ 48.0/ 36.0/ 24.0/ 18.0/ 12.0/ 9.0/ 6.0Mbps 802.11n: up to 150Mbps
OPERATING FREQUENCY	2412 ~ 2462MHz
NUMBER OF CHANNEL	11 for 802.11b, 802.11g, 802.11n (20MHz) 7 for 802.11n (40MHz)
OUTPUT POWER	138.995mW
ANTENNA TYPE	PCB antenna with 1.67dBi gain
ANTENNA CONNECTOR	IPEX
DATA CABLE	NA
I/O PORTS	Refer to user’s manual
ACCESSORY DEVICES	Adapter, Cradle, Stylus, Battery

NOTE:

1. This is a supplementary report of RF130521C18-2. This report shall be combined together with its original report.
2. This report is prepared for FCC class II permissive change. Difference compared with the original report is adding external battery pack. Therefore, the conducted emission and radiated emission below 1GHz tests had been re-tested and presented in the test report.
3. All models are electrically identical, different model names are for marketing purpose. Model PWS-770 is the representative for final test.

Brand	Model
Advantech	PWS-770xxxxxxxxxxxxxxxxxx (“x” can be 0-9 or A-Z or blank or any alphanumeric character for marketing purpose)

4. The EUT provides one completed transmitter and one receiver.

MODULATION MODE	TX FUNCTION
802.11b	1TX
802.11g	1TX
802.11n (20MHz)	1TX
802.11n (40MHz)	1TX



A D T

5. The EUT contains the following accessories. (New External Battery Pack is marked in boldface.)

No.	Product	Brand	Model	Description
1	Adapter	FSP GROUP INC.	FSP065-RAB	Input: 100-240Vac, 1.5A, 50-60Hz Output: 19Vdc, 3.42A Power Line: 1.5m cable with 1 core attached on adapter
2	Battery Pack	Joules	1760001576	Rating: 11.1Vdc, 1880mA, 20.87Wh Type: Li-ion
3	Cradle 1	ADVANTECH	pws-770 cradle	Rating: 19Vdc, 3.42A
4	Cradle 2	ADVANTECH	pws-770 vehicle cradle	Rating: 18.5Vdc, 4.9A
5	External Battery Pack	JOULES MILES CO., LTD.	PWS-770-01	Rating: 11.1Vdc, 5000mA, 55.5Wh

6. The above EUT information is declared by the manufacturer and for more detailed feature description, please refer to the manufacturer's specifications or User's Manual.



3.2 DESCRIPTION OF TEST MODES

11 channels are provided for 802.11b, 802.11g and 802.11n (20MHz):

CHANNEL	FREQUENCY	CHANNEL	FREQUENCY
1	2412MHz	7	2442MHz
2	2417MHz	8	2447MHz
3	2422MHz	9	2452MHz
4	2427MHz	10	2457MHz
5	2432MHz	11	2462MHz
6	2437MHz		

7 channels are provided for 802.11n (40MHz):

CHANNEL	FREQUENCY	CHANNEL	FREQUENCY
3	2422MHz	7	2442MHz
4	2427MHz	8	2447MHz
5	2432MHz	9	2452MHz
6	2437MHz		



3.2.1 TEST MODE APPLICABILITY AND TESTED CHANNEL DETAIL

EUT CONFIGURE MODE	APPLICABLE TO		DESCRIPTION
	RE<1G	PLC	
A	√	√	EUT with external battery pack, Cradle 1
B	√	√	EUT with external battery pack, Cradle 2
C	√	√	EUT with external battery pack, without Cradle

Where **RE<1G**: Radiated Emission below 1GHz **PLC**: Power Line Conducted Emission

NOTE: The EUT had been pre-tested on the positioned of each 3 axis. The worst case was found when positioned on Y-plane.

RADIATED EMISSION TEST (BELOW 1GHz):

- Pre-Scan has been conducted to determine the worst-case mode from all possible combinations between available modulations, data rates and antenna ports (if EUT with antenna diversity architecture).
- Following channel(s) was (were) selected for the final test as listed below.

EUT CONFIGURE MODE	MODE	AVAILABLE CHANNEL	TESTED CHANNEL	MODULATION TECHNOLOGY	MODULATION TYPE	DATA RATE (Mbps)
A, B, C	802.11n (20MHz)	1 to 11	6	OFDM	BPSK	6.5

POWER LINE CONDUCTED EMISSION TEST:

- Pre-Scan has been conducted to determine the worst-case mode from all possible combinations between available modulations, data rates and antenna ports (if EUT with antenna diversity architecture).
- Following channel(s) was (were) selected for the final test as listed below.

EUT CONFIGURE MODE	MODE	AVAILABLE CHANNEL	TESTED CHANNEL	MODULATION TECHNOLOGY	MODULATION TYPE	DATA RATE (Mbps)
A, B, C	802.11n (20MHz)	1 to 11	6	OFDM	BPSK	6.5

TEST CONDITION:

APPLICABLE TO	ENVIRONMENTAL CONDITIONS	INPUT POWER	TESTED BY
RE<1G	25deg. C, 65%RH	120Vac, 60Hz	Brad Tung
PLC	25deg. C, 65%RH	120Vac, 60Hz	Alan Wu



A D T

3.3 DESCRIPTION OF SUPPORT UNITS

The EUT has been tested as an independent unit together with other necessary accessories or support units. The following support units or accessories were used to form a representative test configuration during the tests.

TEST MODE A, B

NO.	PRODUCT	BRAND	MODEL NO.	SERIAL NO.	FCC ID
1	KEYBOARD	DELL	KB4021	CN-05V23T-71581-1A K-01Q2-A01	FCC DoC Approved
2	MOUSE	DELL	MS111-P	CN-011D3V-71581-1C J-019E	FCC DoC Approved
3	USB FLASH DRIVE	Transcend	V85	538455 4490	N/A
4	USB FLASH DRIVE	Transcend	V85	538455 4489	N/A
5	NOTEBOOK	DELL	E5410	6RP2YM1	FCC DoC Approved

NO.	SIGNAL CABLE DESCRIPTION OF THE ABOVE SUPPORT UNITS
1	1.8m foil shielded wire, USB connector, w/o core
2	1.8m foil shielded wire, USB connector, w/o core
3	N/A
4	N/A
5	10m RJ45cable, w/o core

NOTE:

1. All power cords of the above support units are non shielded (1.8m).
2. Item 5 acted as communication partner to transfer data.

TEST MODE C

NO.	PRODUCT	BRAND	MODEL NO.	SERIAL NO.	FCC ID
1	USB FLASH	SANDISK	SDCZ6-1024	N/A	N/A

NO.	SIGNAL CABLE DESCRIPTION OF THE ABOVE SUPPORT UNITS
1	N/A

3.3.1 CONFIGURATION OF SYSTEM UNDER TEST

TEST MODE A, B

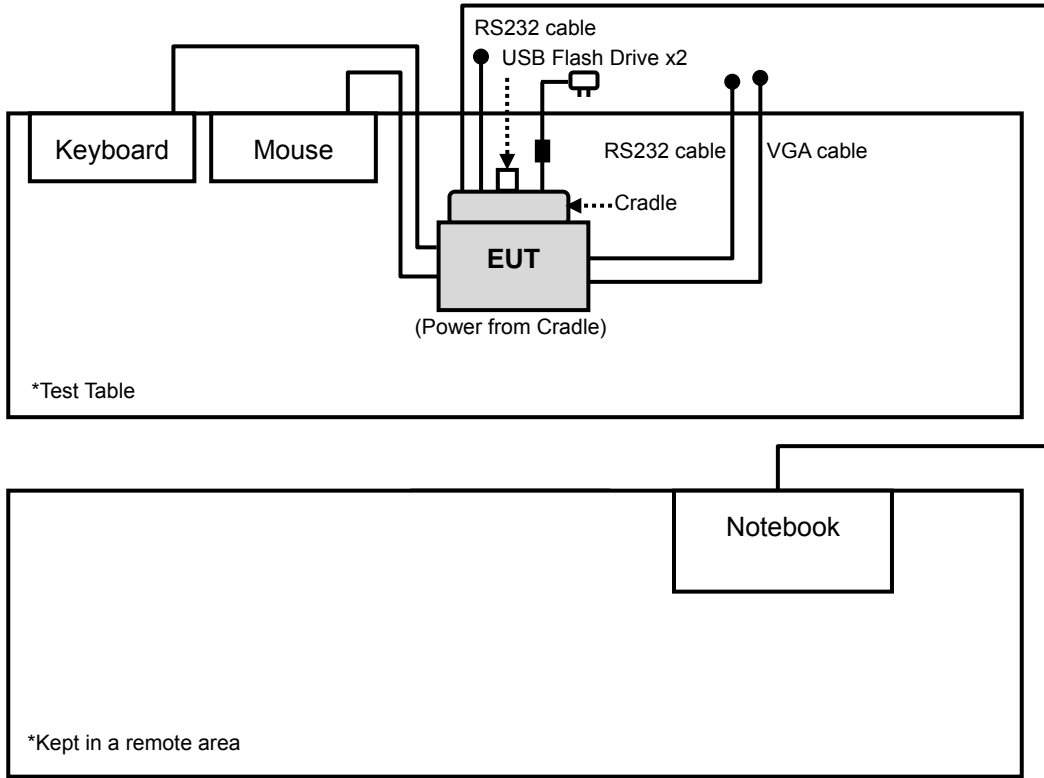

TEST MODE C

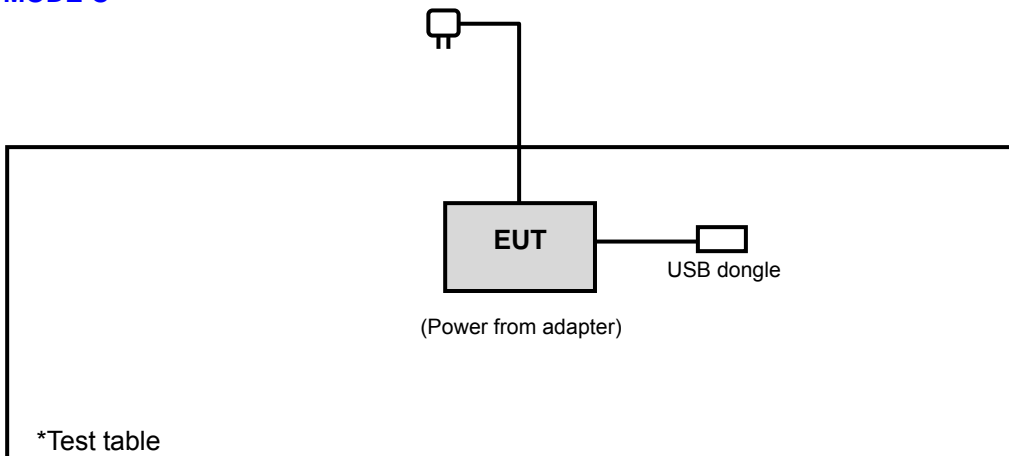

3.4 GENERAL DESCRIPTION OF APPLIED STANDARDS

The EUT is a RF Product. According to the specifications of the manufacturer, it must comply with the requirements of the following standards:

FCC Part 15, Subpart C (15.247)

558074 D01 DTS Meas Guidance v03r01

ANSI C63.10-2009

All test items have been performed and recorded as per the above standards.

NOTE: The EUT is also considered as a kind of computer peripheral, because the connection to computer is necessary for typical use. It has been verified to comply with the requirements of FCC Part 15, Subpart B, Class B (DoC). The test report has been issued separately.

4. TEST TYPES AND RESULTS

4.1 RADIATED EMISSION AND BANDEDGE MEASUREMENT

4.1.1 LIMITS OF RADIATED EMISSION AND BANDEDGE MEASUREMENT

Radiated emissions which fall in the restricted bands must comply with the radiated emission limits specified as below table. Other emissions shall be at least 20dB below the highest level of the desired power:

FREQUENCIES (MHz)	FIELD STRENGTH (microvolts/meter)	MEASUREMENT DISTANCE (meters)
0.009 ~ 0.490	2400/F(kHz)	300
0.490 ~ 1.705	24000/F(kHz)	30
1.705 ~ 30.0	30	30
30 ~ 88	100	3
88 ~ 216	150	3
216 ~ 960	200	3
Above 960	500	3

NOTE:

1. The lower limit shall apply at the transition frequencies.
2. Emission level (dBuV/m) = 20 log Emission level (uV/m).
3. For frequencies above 1000MHz, the field strength limits are based on average detector, however, the peak field strength of any emission shall not exceed the maximum permitted average limits, specified above by more than 20dB under any condition of modulation.

4.1.2 TEST INSTRUMENTS

DESCRIPTION & MANUFACTURER	MODEL NO.	SERIAL NO.	DATE OF CALIBRATION	DUE DATE OF CALIBRATION
Test Receiver ROHDE & SCHWARZ	ESI7	838496/016	Dec. 25, 2012	Dec. 24, 2013
Spectrum Analyzer ROHDE & SCHWARZ	FSP40	100039	Jan. 31, 2013	Jan. 30, 2014
BILOG Antenna SCHWARZBECK	VULB9168	9168-160	Mar. 20, 2013	Mar. 19, 2014
HORN Antenna SCHWARZBECK	9120D	209	Sep. 12, 2013	Sep. 11, 2014
HORN Antenna SCHWARZBECK	BBHA 9170	148	Jul. 15, 2013	Jul. 14, 2014
Preamplifier Agilent	8447D	2944A10633	Oct. 25, 2012	Oct. 24, 2013
Preamplifier Agilent	8449B	3008A01964	Oct. 25, 2012	Oct. 24, 2013
RF signal cable HUBER+SUHNNER	SUCOFLEX 104	250723/4	Aug. 23, 2013	Aug. 22, 2014
RF signal cable HUBER+SUHNNER	SUCOFLEX 106	12738/6+309224/ 4	Aug. 23, 2013	Aug. 22, 2014
Software BV ADT	ADT_Radiated_ V7.6.15.9.4	NA	NA	NA
Antenna Tower inn-co GmbH	MA 4000	013303	NA	NA
Antenna Tower Controller inn-co GmbH	CO2000	017303	NA	NA
Turn Table BV ADT	TT100	TT93021703	NA	NA
Turn Table Controller BV ADT	SC100	SC93021703	NA	NA

- NOTE:** 1. The calibration interval of the above test instruments is 12 months and the calibrations are traceable to NML/ROC and NIST/USA.
2. The test was performed in HwaYa Chamber 3.
3. The horn antenna and HP preamplifier (model: 8449B) are used only for the measurement of emission frequency above 1GHz if tested.
4. The FCC Site Registration No. is 988962.
5. The IC Site Registration No. is IC 7450F-3.

4.1.3 TEST PROCEDURES

- a. The EUT was placed on the top of a rotating table 0.8 meters above the ground at a 3 meters semi-anechoic chamber. The table was rotated 360 degrees to determine the position of the highest radiation.
- b. The EUT was set 3 meters away from the interference-receiving antenna, which was mounted on the top of a variable-height antenna tower.
- c. Height of receiving antenna is varied from one meter to four meters above the ground to determine the maximum value of the field strength. Both horizontal and vertical polarizations of the antenna are set to make the measurement.
- d. For each suspected emission, the EUT was arranged to its worst case and then the antenna was tuned to heights from 1 meter to 4 meters and the rotatable table was turned from 0 degrees to 360 degrees to find the maximum reading.
- e. The test-receiver system was set to Peak Detect Function and Specified Bandwidth with Maximum Hold Mode.
- f. If the emission level of the EUT in peak mode was lower than the limit specified, then testing could be stopped and the peak values of the EUT would be reported. Otherwise the emissions would be re-tested one by one using peak, quasi-peak or average method as specified and then reported in a data sheet.

NOTE:

1. The resolution bandwidth and video bandwidth of test receiver/spectrum analyzer is 120kHz for Quasi-peak detection at frequency below 1GHz.
2. The resolution bandwidth of test receiver/spectrum analyzer is 1MHz and video bandwidth is 3MHz for Peak detection at frequency above 1GHz.
3. The resolution bandwidth of test receiver/spectrum analyzer is 1MHz and the video bandwidth is 1kHz(Duty cycle < 98%) or 10Hz(Duty cycle > 98%) for Average detection (AV) at frequency above 1GHz.
4. All modes of operation were investigated and the worst-case emissions are reported.

4.1.4 DEVIATION FROM TEST STANDARD

No deviation.

4.1.5 TEST SETUP

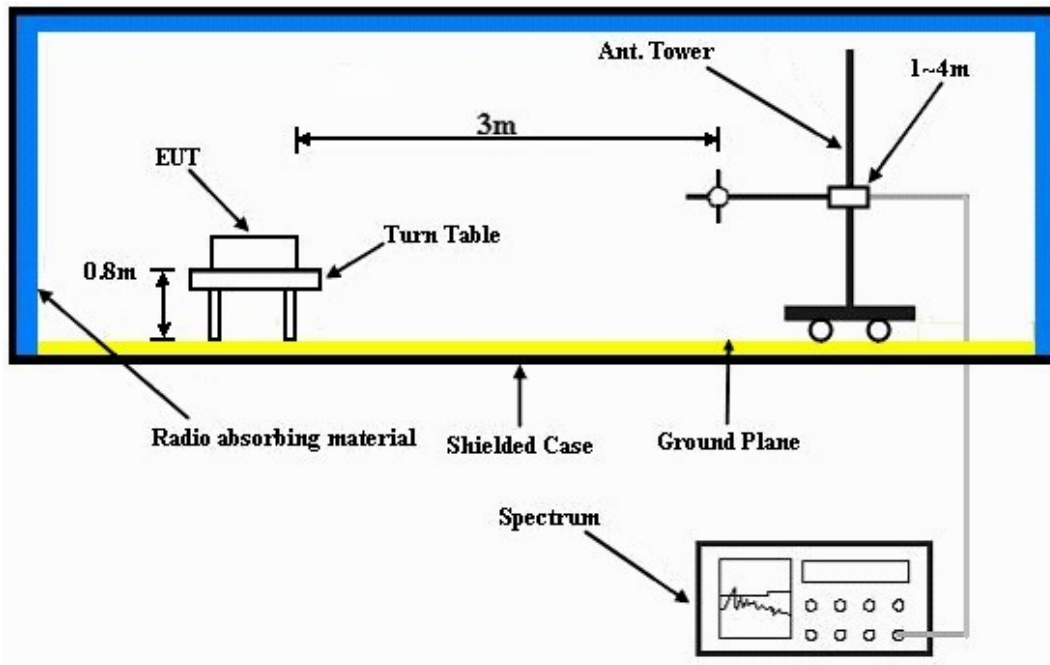

For the actual test configuration, please refer to the attached file (Test Setup Photo).

4.1.6 EUT OPERATING CONDITIONS

TEST MODE A, B

- Placed the EUT on the testing table.
- The notebook connected with EUT via a RJ45 cable and run a test program (provided by manufacturer) to enable EUT under transmission condition continuously at specific channel frequency.

TEST MODE C

- Placed the EUT on the testing table.
- The USB Flash connected with EUT via a USB cable and run a test program (provided by manufacturer) to enable EUT under transmission condition continuously at specific channel frequency.



A D T

4.1.7 TEST RESULTS

BELOW 1GHz WORST-CASE DATA : 802.11n (20MHz)

EUT TEST CONDITION		MEASUREMENT DETAIL	
CHANNEL	Channel 6	FREQUENCY RANGE	Below 1000MHz
INPUT POWER	120Vac, 60Hz	DETECTOR FUNCTION	Quasi-Peak
ENVIRONMENTAL CONDITIONS	25deg. C, 65%RH	TESTED BY	Brad Tung
TEST MODE	A		

ANTENNA POLARITY & TEST DISTANCE: HORIZONTAL AT 3 M								
NO.	FREQ. (MHz)	EMISSION LEVEL (dBuV/m)	LIMIT (dBuV/m)	MARGIN (dB)	ANTENNA HEIGHT (m)	TABLE ANGLE (Degree)	RAW VALUE (dBuV)	CORRECTION FACTOR (dB/m)
1	49.30	24.1 QP	40.0	-15.9	1.00 H	16	38.70	-14.60
2	198.71	35.6 QP	43.5	-7.9	1.00 H	94	52.40	-16.80
3	699.34	37.8 QP	46.0	-8.2	3.00 H	137	43.20	-5.40
4	747.85	33.6 QP	46.0	-12.4	1.50 H	159	37.60	-4.00
5	800.24	37.3 QP	46.0	-8.7	1.00 H	150	40.40	-3.10
6	858.45	33.7 QP	46.0	-12.3	2.00 H	352	36.10	-2.40

ANTENNA POLARITY & TEST DISTANCE: VERTICAL AT 3 M								
NO.	FREQ. (MHz)	EMISSION LEVEL (dBuV/m)	LIMIT (dBuV/m)	MARGIN (dB)	ANTENNA HEIGHT (m)	TABLE ANGLE (Degree)	RAW VALUE (dBuV)	CORRECTION FACTOR (dB/m)
1	49.30	33.2 QP	40.0	-6.8	1.75 V	9	47.80	-14.60
2	99.75	32.4 QP	43.5	-11.1	1.50 V	314	51.00	-18.60
3	198.71	37.0 QP	43.5	-6.5	1.00 V	175	53.80	-16.80
4	497.54	26.5 QP	46.0	-19.5	1.00 V	110	35.50	-9.00
5	699.34	30.7 QP	46.0	-15.3	1.00 V	184	36.10	-5.40
6	800.24	28.2 QP	46.0	-17.8	2.00 V	123	31.30	-3.10

REMARKS:

- Emission Level(dBuV/m) = Raw Value(dBuV) + Correction Factor(dB/m)
- Correction Factor(dB/m) = Antenna Factor(dB/m) + Cable Factor(dB) – Pre-Amplifier Factor (dB)
- The other emission levels were very low against the limit.
- Margin value = Emission Level – Limit value



A D T

EUT TEST CONDITION		MEASUREMENT DETAIL	
CHANNEL	Channel 6	FREQUENCY RANGE	Below 1000MHz
INPUT POWER	120Vac, 60Hz	DETECTOR FUNCTION	Quasi-Peak
ENVIRONMENTAL CONDITIONS	25deg. C, 65%RH	TESTED BY	Brad Tung
TEST MODE	B		

ANTENNA POLARITY & TEST DISTANCE: HORIZONTAL AT 3 M								
NO.	FREQ. (MHz)	EMISSION LEVEL (dBuV/m)	LIMIT (dBuV/m)	MARGIN (dB)	ANTENNA HEIGHT (m)	TABLE ANGLE (Degree)	RAW VALUE (dBuV)	CORRECTION FACTOR (dB/m)
1	49.30	28.8 QP	40.0	-11.2	1.50 H	83	43.40	-14.60
2	198.71	36.1 QP	43.5	-7.4	1.00 H	92	52.90	-16.80
3	400.52	27.5 QP	46.0	-18.5	2.00 H	166	38.40	-10.90
4	699.34	39.0 QP	46.0	-7.0	1.00 H	151	44.40	-5.40
5	800.24	39.2 QP	46.0	-6.8	1.00 H	151	42.30	-3.10
6	856.51	34.1 QP	46.0	-11.9	1.50 H	9	36.50	-2.40
ANTENNA POLARITY & TEST DISTANCE: VERTICAL AT 3 M								
NO.	FREQ. (MHz)	EMISSION LEVEL (dBuV/m)	LIMIT (dBuV/m)	MARGIN (dB)	ANTENNA HEIGHT (m)	TABLE ANGLE (Degree)	RAW VALUE (dBuV)	CORRECTION FACTOR (dB/m)
1	49.30	32.7 QP	40.0	-7.3	1.00 V	289	47.30	-14.60
2	99.75	32.2 QP	43.5	-11.3	1.25 V	315	50.80	-18.60
3	198.71	36.8 QP	43.5	-6.7	1.00 V	183	53.60	-16.80
4	499.48	26.6 QP	46.0	-19.4	1.00 V	140	35.60	-9.00
5	699.34	30.7 QP	46.0	-15.3	1.75 V	180	36.10	-5.40
6	800.24	28.4 QP	46.0	-17.6	1.50 V	115	31.50	-3.10

REMARKS:

1. Emission Level(dBuV/m) = Raw Value(dBuV) + Correction Factor(dB/m)
2. Correction Factor(dB/m) = Antenna Factor(dB/m) + Cable Factor(dB)
– Pre-Amplifier Factor (dB)
3. The other emission levels were very low against the limit.
4. Margin value = Emission Level – Limit value



A D T

EUT TEST CONDITION		MEASUREMENT DETAIL	
CHANNEL	Channel 6	FREQUENCY RANGE	Below 1000MHz
INPUT POWER	120Vac, 60Hz	DETECTOR FUNCTION	Quasi-Peak
ENVIRONMENTAL CONDITIONS	25deg. C, 65%RH	TESTED BY	Brad Tung
TEST MODE	C		

ANTENNA POLARITY & TEST DISTANCE: HORIZONTAL AT 3 M								
NO.	FREQ. (MHz)	EMISSION LEVEL (dBuV/m)	LIMIT (dBuV/m)	MARGIN (dB)	ANTENNA HEIGHT (m)	TABLE ANGLE (Degree)	RAW VALUE (dBuV)	CORRECTION FACTOR (dB/m)
1	49.30	28.8 QP	40.0	-11.2	1.75 H	9	43.40	-14.60
2	198.71	36.1 QP	43.5	-7.4	1.50 H	103	52.90	-16.80
3	388.87	27.4 QP	46.0	-18.6	1.25 H	121	38.30	-10.90
4	699.34	37.7 QP	46.0	-8.3	1.00 H	144	43.10	-5.40
5	800.24	37.6 QP	46.0	-8.4	1.25 H	149	40.70	-3.10
6	856.51	33.8 QP	46.0	-12.2	1.00 H	9	36.20	-2.40
ANTENNA POLARITY & TEST DISTANCE: VERTICAL AT 3 M								
NO.	FREQ. (MHz)	EMISSION LEVEL (dBuV/m)	LIMIT (dBuV/m)	MARGIN (dB)	ANTENNA HEIGHT (m)	TABLE ANGLE (Degree)	RAW VALUE (dBuV)	CORRECTION FACTOR (dB/m)
1	49.30	32.9 QP	40.0	-7.1	1.25 V	8	47.50	-14.60
2	99.75	32.5 QP	43.5	-11.0	1.00 V	51	51.10	-18.60
3	198.71	35.8 QP	43.5	-7.7	1.50 V	182	52.60	-16.80
4	499.48	25.8 QP	46.0	-20.2	2.00 V	111	34.80	-9.00
5	697.40	31.1 QP	46.0	-14.9	1.00 V	179	36.50	-5.40
6	800.24	27.2 QP	46.0	-18.8	1.25 V	122	30.30	-3.10

REMARKS:

1. Emission Level(dBuV/m) = Raw Value(dBuV) + Correction Factor(dB/m)
2. Correction Factor(dB/m) = Antenna Factor(dB/m) + Cable Factor(dB)
– Pre-Amplifier Factor (dB)
3. The other emission levels were very low against the limit.
4. Margin value = Emission Level – Limit value



A D T

4.2 CONDUCTED EMISSION MEASUREMENT

4.2.1 LIMITS OF CONDUCTED EMISSION MEASUREMENT

FREQUENCY OF EMISSION (MHz)	CONDUCTED LIMIT (dB μ V)	
	Quasi-peak	Average
0.15 ~ 0.5	66 to 56	56 to 46
0.5 ~ 5	56	46
5 ~ 30	60	50

- NOTE:** 1. The lower limit shall apply at the transition frequencies.
2. The limit decreases in line with the logarithm of the frequency in the range of 0.15 to 0.50MHz.
3. All emanations from a class A/B digital device or system, including any network of conductors and apparatus connected thereto, shall not exceed the level of field strengths specified above.

4.2.2 TEST INSTRUMENTS

DESCRIPTION & MANUFACTURER	MODEL NO.	SERIAL NO.	DATE OF CALIBRATION	DUE DATE OF CALIBRATION
Test Receiver ROHDE & SCHWARZ	ESCS30	100288	Nov. 09, 2012	Nov. 08, 2013
RF signal cable Woken	5D-FB	Cable-HYCO2-01	Dec. 28, 2012	Dec. 27, 2013
LISN ROHDE & SCHWARZ (EUT)	ESH2-Z5	100100	Dec. 21, 2012	Dec. 20, 2013
LISN ROHDE & SCHWARZ (Peripheral)	ESH3-Z5	100311	Jul. 17, 2013	Jul. 16, 2014
Software ADT	BV ADT_Cond_ V7.3.7.3	NA	NA	NA

- NOTE:** 1. The calibration interval of the above test instruments is 12 months and the calibrations are traceable to NML/ROC and NIST/USA.
2. The test was performed in HwaYa Shielded Room 2.
3. The VCCI Site Registration No. is C-2047.

4.2.3 TEST PROCEDURES

- The EUT was placed 0.4 meters from the conducting wall of the shielded room with EUT being connected to the power mains through a line impedance stabilization network (LISN). Other support units were connected to the power mains through another LISN. The two LISNs provide 50 ohm/ 50uH of coupling impedance for the measuring instrument.
- Both lines of the power mains connected to the EUT were checked for maximum conducted interference.
- The frequency range from 150kHz to 30MHz was searched. Emission levels under (Limit - 20dB) was not recorded.

NOTE: All modes of operation were investigated and the worst-case emissions are reported.

4.2.4 DEVIATION FROM TEST STANDARD

No deviation.

4.2.5 TEST SETUP

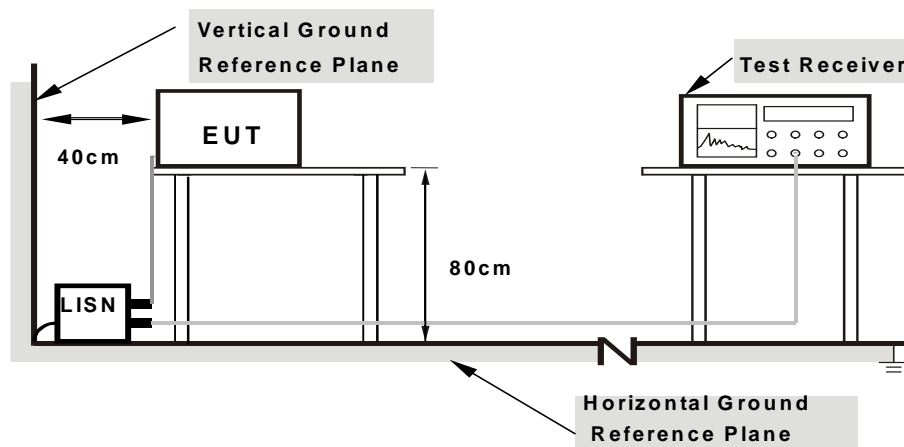

Note: 1.Support units were connected to second LISN.
2.Both of LISNs (AMN) are 80 cm from EUT and at least 80 from other units and other metal planes

For the actual test configuration, please refer to the attached file (Test Setup Photo).

4.2.6 EUT OPERATING CONDITIONS

Same as 4.1.6.

4.2.7 TEST RESULTS

CONDUCTED WORST-CASE DATA : 802.11n (20MHz)

PHASE	Line 1	6dB BANDWIDTH	9kHz
TEST MODE	A		

No	Freq. [MHz]	Corr. Factor (dB)	Reading Value		Emission Level		Limit		Margin	
			[dB (uV)]		[dB (uV)]		[dB (uV)]		(dB)	
			Q.P.	AV.	Q.P.	AV.	Q.P.	AV.	Q.P.	AV.
1	0.18906	0.17	43.13	29.03	43.30	29.20	64.08	54.08	-20.78	-24.88
2	0.66172	0.24	39.97	17.91	40.21	18.15	56.00	46.00	-15.79	-27.85
3	0.82969	0.25	43.11	28.90	43.36	29.15	56.00	46.00	-12.64	-16.85
4	0.98203	0.27	41.74	23.73	42.01	24.00	56.00	46.00	-13.99	-22.00
5	1.27734	0.27	39.20	18.91	39.47	19.18	56.00	46.00	-16.53	-26.82
6	17.58203	0.59	38.44	29.21	39.03	29.80	60.00	50.00	-20.97	-20.20

REMARKS:

1. Q.P. and AV. are abbreviations of quasi-peak and average individually.
2. The emission levels of other frequencies were very low against the limit.
3. Margin value = Emission level - Limit value
4. Correction factor = Insertion loss + Cable loss
5. Emission Level = Correction Factor + Reading Value.

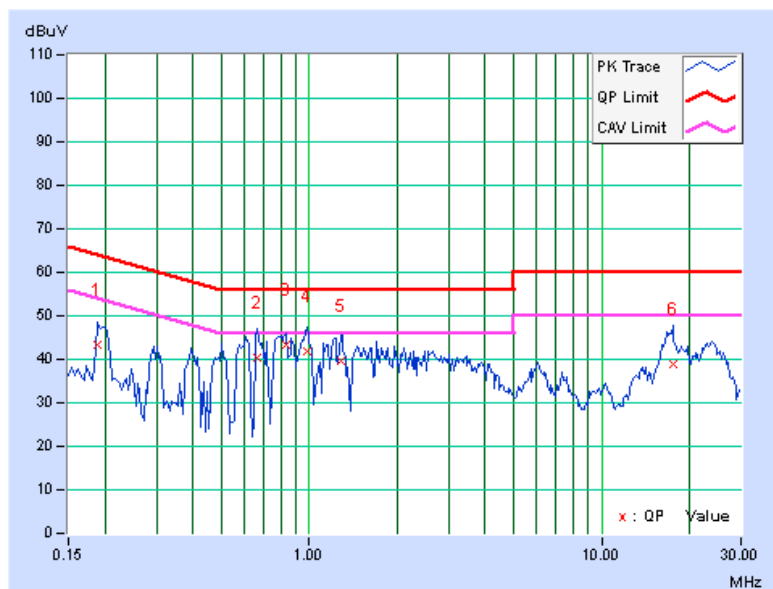



A D T

PHASE	Line 2	6dB BANDWIDTH	9kHz
TEST MODE	A		

No	Freq. [MHz]	Corr. Factor (dB)	Reading Value		Emission Level		Limit		Margin	
			[dB (uV)]		[dB (uV)]		[dB (uV)]		(dB)	
			Q.P.	AV.	Q.P.	AV.	Q.P.	AV.	Q.P.	AV.
1	0.19297	0.18	41.48	32.37	41.66	32.55	63.91	53.91	-22.25	-21.36
2	0.59922	0.24	41.17	26.82	41.41	27.06	56.00	46.00	-14.59	-18.94
3	0.79453	0.24	42.07	25.93	42.31	26.17	56.00	46.00	-13.69	-19.83
4	0.99375	0.23	41.99	24.39	42.22	24.62	56.00	46.00	-13.78	-21.38
5	1.16016	0.24	40.57	20.69	40.81	20.93	56.00	46.00	-15.19	-25.07
6	16.91797	0.65	36.64	28.24	37.29	28.89	60.00	50.00	-22.71	-21.11

REMARKS:

1. Q.P. and AV. are abbreviations of quasi-peak and average individually.
2. The emission levels of other frequencies were very low against the limit.
3. Margin value = Emission level - Limit value
4. Correction factor = Insertion loss + Cable loss
5. Emission Level = Correction Factor + Reading Value.

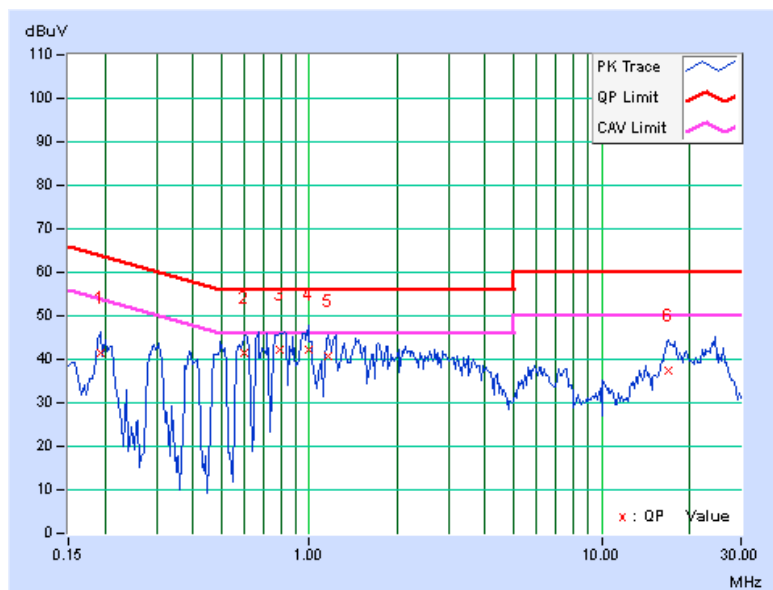

PHASE	Line 1	6dB BANDWIDTH	9kHz
TEST MODE	B		

No	Freq. [MHz]	Corr. Factor (dB)	Reading Value		Emission Level		Limit		Margin	
			[dB (uV)]		[dB (uV)]		[dB (uV)]		(dB)	
			Q.P.	AV.	Q.P.	AV.	Q.P.	AV.	Q.P.	AV.
1	0.20859	0.17	42.40	31.10	42.57	31.27	63.26	53.26	-20.69	-21.99
2	0.29063	0.19	39.17	27.71	39.36	27.90	60.51	50.51	-21.15	-22.61
3	0.84531	0.25	37.97	16.80	38.22	17.05	56.00	46.00	-17.78	-28.95
4	0.94297	0.26	41.57	21.52	41.83	21.78	56.00	46.00	-14.17	-24.22
5	1.32422	0.27	39.54	23.92	39.81	24.19	56.00	46.00	-16.19	-21.81
6	16.82031	0.57	39.24	29.55	39.81	30.12	60.00	50.00	-20.19	-19.88

REMARKS:

1. Q.P. and AV. are abbreviations of quasi-peak and average individually.
2. The emission levels of other frequencies were very low against the limit.
3. Margin value = Emission level - Limit value
4. Correction factor = Insertion loss + Cable loss
5. Emission Level = Correction Factor + Reading Value.

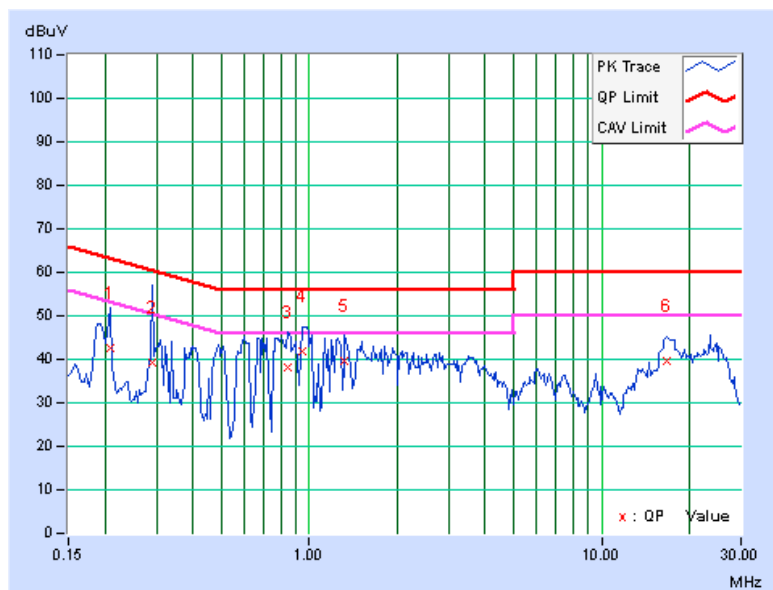

PHASE	Line 2	6dB BANDWIDTH	9kHz
TEST MODE	B		

No	Freq. [MHz]	Corr. Factor (dB)	Reading Value		Emission Level		Limit		Margin	
			[dB (uV)]		[dB (uV)]		[dB (uV)]		(dB)	
			Q.P.	AV.	Q.P.	AV.	Q.P.	AV.	Q.P.	AV.
1	0.19687	0.18	43.05	34.41	43.23	34.59	63.74	53.74	-20.51	-19.15
2	0.68906	0.24	39.24	21.03	39.48	21.27	56.00	46.00	-16.52	-24.73
3	0.78281	0.24	41.57	25.40	41.81	25.64	56.00	46.00	-14.19	-20.36
4	0.95859	0.23	41.74	23.69	41.97	23.92	56.00	46.00	-14.03	-22.08
5	1.33984	0.25	40.29	25.67	40.54	25.92	56.00	46.00	-15.46	-20.08
6	17.22266	0.66	36.74	28.26	37.40	28.92	60.00	50.00	-22.60	-21.08

REMARKS:

1. Q.P. and AV. are abbreviations of quasi-peak and average individually.
2. The emission levels of other frequencies were very low against the limit.
3. Margin value = Emission level - Limit value
4. Correction factor = Insertion loss + Cable loss
5. Emission Level = Correction Factor + Reading Value.

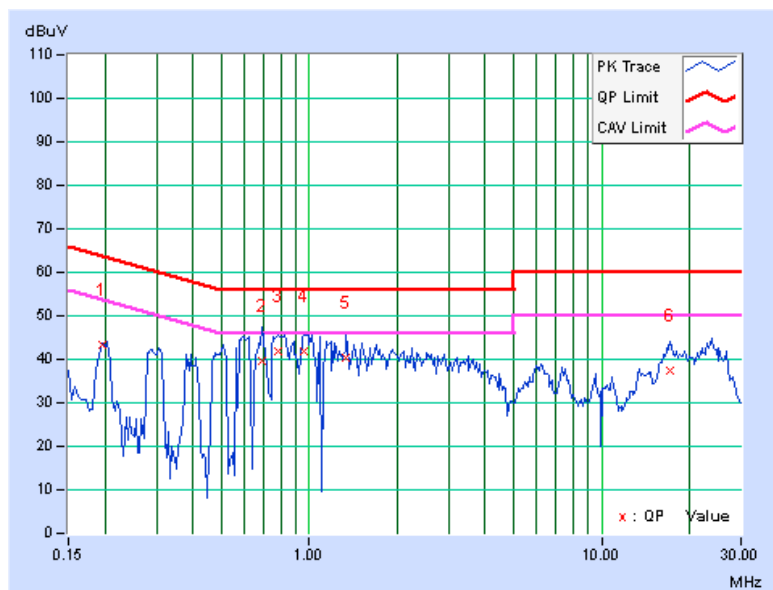



A D T

PHASE	Line 1	6dB BANDWIDTH	9kHz
TEST MODE	C		

No	Freq. [MHz]	Corr. Factor (dB)	Reading Value		Emission Level		Limit		Margin	
			[dB (uV)]		[dB (uV)]		[dB (uV)]		(dB)	
			Q.P.	AV.	Q.P.	AV.	Q.P.	AV.	Q.P.	AV.
1	0.20469	0.17	44.50	35.24	44.67	35.41	63.42	53.42	-18.75	-18.01
2	0.61875	0.23	42.07	30.21	42.30	30.44	56.00	46.00	-13.70	-15.56
3	0.68125	0.24	39.36	19.77	39.60	20.01	56.00	46.00	-16.40	-25.99
4	0.94297	0.26	40.67	18.35	40.93	18.61	56.00	46.00	-15.07	-27.39
5	1.26172	0.27	38.82	18.53	39.09	18.80	56.00	46.00	-16.91	-27.20
6	17.08203	0.58	38.56	29.34	39.14	29.92	60.00	50.00	-20.86	-20.08

REMARKS:

1. Q.P. and AV. are abbreviations of quasi-peak and average individually.
2. The emission levels of other frequencies were very low against the limit.
3. Margin value = Emission level - Limit value
4. Correction factor = Insertion loss + Cable loss
5. Emission Level = Correction Factor + Reading Value.

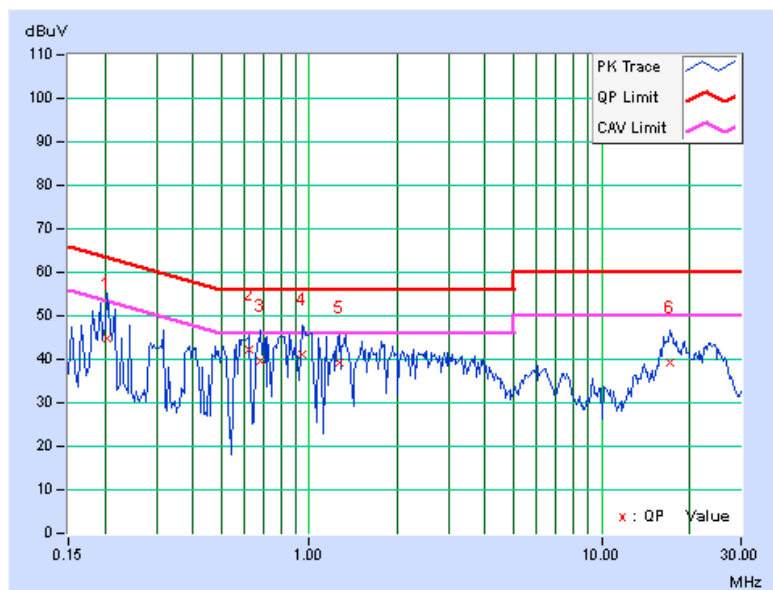

PHASE	Line 2	6dB BANDWIDTH	9kHz
TEST MODE	C		

No	Freq. [MHz]	Corr. Factor (dB)	Reading Value		Emission Level		Limit		Margin	
			[dB (uV)]		[dB (uV)]		[dB (uV)]		(dB)	
			Q.P.	AV.	Q.P.	AV.	Q.P.	AV.	Q.P.	AV.
1	0.18906	0.18	41.37	28.57	41.55	28.75	64.08	54.08	-22.53	-25.33
2	0.62266	0.24	42.39	29.01	42.63	29.25	56.00	46.00	-13.37	-16.75
3	0.69297	0.24	39.44	21.05	39.68	21.29	56.00	46.00	-16.32	-24.71
4	0.85313	0.23	39.51	18.82	39.74	19.05	56.00	46.00	-16.26	-26.95
5	1.33594	0.25	40.69	25.46	40.94	25.71	56.00	46.00	-15.06	-20.29
6	16.65234	0.65	36.29	27.29	36.94	27.94	60.00	50.00	-23.06	-22.06

REMARKS:

1. Q.P. and AV. are abbreviations of quasi-peak and average individually.
2. The emission levels of other frequencies were very low against the limit.
3. Margin value = Emission level - Limit value
4. Correction factor = Insertion loss + Cable loss
5. Emission Level = Correction Factor + Reading Value.

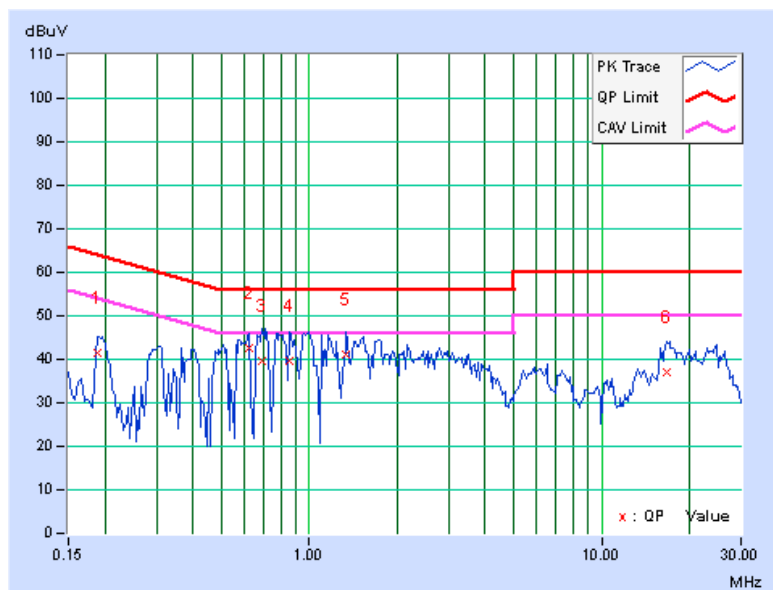

5. PHOTOGRAPHS OF THE TEST CONFIGURATION

Please refer to the attached file (Test Setup Photo).



6. INFORMATION ON THE TESTING LABORATORIES

We, Bureau Veritas Consumer Products Services (H.K.) Ltd., Taoyuan Branch, were founded in 1988 to provide our best service in EMC, Radio, Telecom and Safety consultation. Our laboratories are accredited and approved according to ISO/IEC 17025.

If you have any comments, please feel free to contact us at the following:

Linko EMC/RF Lab:

Tel: 886-2-26052180

Fax: 886-2-26051924

Hsin Chu EMC/RF Lab:

Tel: 886-3-5935343

Fax: 886-3-5935342

Hwa Ya EMC/RF/Safety Telecom Lab:

Tel: 886-3-3183232

Fax: 886-3-3270892

Email: service.adt@tw.bureauveritas.com

Web Site: www.bureauveritas-adt.com

The address and road map of all our labs can be found in our web site also.



A D T

7. APPENDIX A - MODIFICATIONS RECORDERS FOR ENGINEERING CHANGES TO THE EUT BY THE LAB

No any modifications are made to the EUT by the lab during the test.

---END---