

**FCC 47 CFR PART 15 SUBPART E AND ANSI C63.10:2013  
TEST REPORT**

**For**

**Computer**

**Model : POC127 ; POC-127XXXXXXXXXXXXXXXXXX ;  
POC127XXXXXXXXXXXXXXXXXX**

(where "X" may be any alphanumeric character , "-" or blank)

**Trade Name : ADVANTECH**

**Issued for**

**Advantech Co. Ltd.**

**No.1, Alley 20, Lane 26, Rueiguang Road, Neihu District, Taipei 114, Taiwan,  
R.O.C.**

**Issued by**

**Compliance Certification Services Inc.  
Hsinchu Lab.**

**No.989-1, Wenshan Rd., Shangshan Village,  
Qionglin Township, Hsinchu County 30741, Taiwan (R.O.C.)**

**TEL: +886-3-5921698**

**FAX: +886-3-5921108**

**<http://www.ccsrf.com>**

**E-Mail : [service@ccsrf.com](mailto:service@ccsrf.com)**

**Issued Date: July 07, 2015**



**Note:** This report shall not be reproduced except in full, without the written approval of Compliance Certification Services Inc. This document may be altered or revised by Compliance Certification Services Inc. personnel only, and shall be noted in the revision section of the document. The client should not use it to claim product endorsement by TAF or any government agencies. The test results of this report relate only to the tested sample identified in this report.

## Revision History

Rev.	Issue Date	Revisions	Effect Page	Revised By
00	07/07/2015	Initial Issue	All Page 291	Michelle Chiu

## TABLE OF CONTENTS

TITLE	PAGE NO.
<b>1. TEST REPORT CERTIFICATION .....</b>	<b>4</b>
<b>2. EUT DESCRIPTION .....</b>	<b>5</b>
<b>3. DESCRIPTION OF TEST MODES .....</b>	<b>8</b>
<b>4. TEST METHODOLOGY .....</b>	<b>11</b>
<b>5. FACILITIES AND ACCREDITATION .....</b>	<b>11</b>
5.1 FACILITIES .....	11
5.2 ACCREDITATIONS.....	11
5.3 MEASUREMENT UNCERTAINTY .....	12
<b>6. SETUP OF EQUIPMENT UNDER TEST.....</b>	<b>13</b>
<b>7. FCC PART 15.407 REQUIREMENTS .....</b>	<b>15</b>
7.1 26dB BANDWIDTH .....	15
7.2 6dB BANDWIDTH .....	35
7.2 MAXIMUM CONDUCTED OUTPUT POWER .....	45
7.3 PEAK POWER SPECTRAL DENSITY .....	56
7.4 RADIATED EMISSION.....	98
7.5 CONDUCTED EMISSION .....	248
7.6 FREQUENCY STABILITY .....	253
<b>APPENDIX SETUP PHOTOS .....</b>	<b>258</b>
<b>EXTERNAL PHOTO.....</b>	<b>262</b>
<b>INTERNAL PHOTO .....</b>	<b>267</b>

# 1. TEST REPORT CERTIFICATION

**Applicant** : Advantech Co. Ltd.  
**Address** : No.1, Alley 20, Lane 26, Rueiguang Road, Neihu District,  
 Taipei 114, Taiwan, R.O.C.  
**Equipment Under Test** : Computer  
**Model** : POC127 ; POC-127XXXXXXXXXXXXXXXXXX ;  
 POC127XXXXXXXXXXXXXXXXXX  
 (where "X" may be any alphanumeric character , "-" or blank)  
**Trade Name** : ADVANTECH  
**Tested Date** : May 22 ~ July 07, 2015

APPLICABLE STANDARD	
Standard	Test Result
FCC Part 15 Subpart E AND ANSI C63.10:2013	PASS

WE HEREBY CERTIFY THAT: The above equipment has been tested by Compliance Certification Services Inc., and found compliance with the requirements set forth in the technical standards mentioned above. The results of testing in this report apply only to the product/system, which was tested. Other similar equipment will not necessarily produce the same results due to production tolerance and measurement uncertainties.

**Approved by:**



Sb. Lu  
Sr. Engineer

**Reviewed by:**



Gundam Lin  
Sr. Engineer

## 2. EUT DESCRIPTION

<b>Product Name</b>	Computer
<b>Model Number</b>	POC127 ; POC-127XXXXXXXXXXXXXXXXXX ; POC127XXXXXXXXXXXXXXXXXX (where "X" may be any alphanumeric character , "-" or blank)
<b>Identify Number</b>	T150522L01
<b>Received Date</b>	May 22, 2015
<b>Frequency Range</b>	<p>UNII Band 1: IEEE 802.11a, 802.11an HT20 : 5180MHz ~ 5240MHz IEEE 802.11an HT40 : 5190MHz ~ 5230MH</p> <p>UNII Band 2A: IEEE 802.11a, 802.11an HT20 : 5260MHz ~ 5320MHz IEEE 802.11an HT40 : 5270MHz ~ 5310MHz</p> <p>UNII Band 2C: IEEE 802.11a, 802.11an HT20 : 5500MHz ~ 5700MHz IEEE 802.11an HT40 : 5510MHz ~ 5670MHz</p> <p>UNII Band 3: IEEE 802.11a, 802.11an HT20 : 5745MHz ~ 5825MHz IEEE 802.11an HT40 : 5755MHz ~ 5795MHz</p>
<b>Transmit Power</b>	<p>UNII Band 1: IEEE 802.11a : 17.36dBm (0.0544W) IEEE 802.11an HT20 : 20.10dBm (0.1023W) IEEE 802.11an HT40 : 19.56dBm (0.0904W)</p> <p>UNII Band 2A: IEEE 802.11a : 17.49dBm (0.0561W) IEEE 802.11an HT20 : 20.05dBm (0.1012W) IEEE 802.11an HT40 : 19.52dBm (0.0895W)</p> <p>UNII Band 2C: IEEE 802.11a : 17.34dBm (0.0542W) IEEE 802.11an HT20 : 19.81dBm (0.0957W) IEEE 802.11an HT40 : 19.69dBm (0.0931 W)</p> <p>UNII Band 3: IEEE 802.11a : 17.66dBm (0.0583W) IEEE 802.11an HT20 : 20.65dBm (0.1161W) IEEE 802.11an HT40 : 18.24dBm (0.0667W)</p>
<b>Channel Spacing</b>	IEEE 802.11a, 802.11an HT20 : 20MHz IEEE 802.11an HT40 : 40MHz

<b>Channel Number</b>	IEEE 802.11a, 802.11an HT20 : 5150MHz ~ 5250MHz : 4 Channels 5250MHz ~ 5350MHz : 4 Channels 5470MHz ~ 5725MHz : 8 Channels 5725MHz ~ 5850MHz : 5 Channels  IEEE 802.11an HT40 : 5150MHz ~ 5250MHz : 2 Channels 5250MHz ~ 5350MHz : 2 Channels 5470MHz ~ 5725MHz : 3 Channels 5725MHz ~ 5850MHz : 2 Channels
<b>Transmit Data Rate</b>	IEEE 802.11a : up to 54 Mbps IEEE 802.11an (HT20,800ns GI) : up to 130.00 Mbps IEEE 802.11an (HT20,400ns GI) : up to 144.40 Mbps IEEE 802.11an (HT40,800ns GI) : up to 270.00 Mbps IEEE 802.11an (HT40,400ns GI) : up to 300.00 Mbps
<b>Type of Modulation</b>	IEEE 802.11a : OFDM (64QAM, 16QAM, QPSK, BPSK) IEEE 802.11an HT20/40 : OFDM (64QAM, 16QAM, QPSK, BPSK)
<b>Antenna Type</b>	PIFA Antenna × 2 : Antenna 1(Main) / Chain 1, Antenna Gain: -5dBi Antenna 2(Aux) / Chain 2, Antenna Gain : -5dBi
<b>Power Rating</b>	18Vdc, 3.5A
<b>Test Voltage</b>	120Vac, 60Hz
<b>DC Power Cable Type</b>	Non-shielded cable, 1.3m × 1 (Non-detachable), with two ferrite core
<b>I/O Port</b>	IEEE 1394 Port × 1, RJ-45 Port × 1, USB Port × 4, VGA Port × 1, RS232 Port × 2, Audio Port × 3, PS/2 Port × 1, Power Port × 1
<b>Signal Cable</b>	Shielded PS/2 cable, 0.2m × 1 (Detachable)

**Power Adapter :**

No.	Manufacturer	Model No.	Power Input	Power Output
1	SINPRO	HPU101-107	100-240Vac, 47-63Hz, 1.2-0.5A	18Vdc, 5.55A max.

**The difference of the series model**

Model Number	Difference
POC127	1. For marketing purpose only. 2. where "X" may be any alphanumeric character , " - " or blank
POC-127XXXXXXXXXXXXXXXXXXXX	
POC127XXXXXXXXXXXXXXXXXXXX	

**Remark :**

1. The sample selected for test was engineering sample that approximated to production product and was provided by manufacturer.
2. For more details, please refer to the User's manual of the EUT.
3. The model POC127 was considered the main model for testing.
4. This submittal(s) (test report) is intended for FCC ID: M82-POC127 filing to comply with Section 15.207, 15.209 and 15.407 of the FCC Part 15, Subpart E Rules.

### 3. DESCRIPTION OF TEST MODES

The EUT is an 802.11n transceiver in Computer form factor.

For IEEE 802.11a mode (1TX / 1RX) : Ant. 1 (Main) / Chain 1 transmit/receive.

For IEEE 802.11an HT20/HT40 mode (2TX / 2RX) :

Ant. 1 (Main) / Chain 1 & Ant. 2 (Aux) / Chain 2 transmit/receive.

#### Conducted Emission / Radiated Emission Test (Below 1 GHz)

1. The following test modes were scanned during the preliminary test:

No.	Pre-Test Mode
1	TX Mode

2. After the preliminary scan, the following test mode was found to produce the highest emission level.

Final Test Mode		
Emission	Radiated Emission	TX Mode
	Conducted Emission	TX Mode

**Remark :** Then, the above highest emission mode of the configuration of the EUT and cable was chosen for all final test items.



**Conducted / Radiated Emission Test (Above 1 GHz)****IEEE 802.11a, 802.11an HT20 mode**

The EUT had been tested under operating condition.

There are three channels have been tested as following :

**UNII Band 1:**

Channel	Frequency (MHz)
Low	5180
Middle	5200
High	5240

**UNII Band 2A:**

Channel	Frequency (MHz)
Low	5260
Middle	5300
High	5320

**UNII Band 2C:**

Channel	Frequency (MHz)
Low	5500
Middle	5580
High	5700

**UNII Band 3:**

Channel	Frequency (MHz)
Low	5745
Middle	5785
High	5825

IEEE 802.11a mode : 6Mbps data rate (worst case) were chosen for full testing.

IEEE 802.11an HT20 mode : 13Mbps data rate (worst case) were chosen for full testing.

**IEEE 802.11an HT40 mode**

The EUT had been tested under operating condition.

There are two and three channels have been tested as following :

**UNII Band 1:**

Channel	Frequency (MHz)
Low	5190
High	5230

**UNII Band 2A:**

Channel	Frequency (MHz)
Low	5270
High	5310

**UNII Band 2C:**

Channel	Frequency (MHz)
Low	5510
Middle	5550
High	5670

**UNII Band 3:**

Channel	Frequency (MHz)
Low	5755
High	5795

IEEE 802.11an HT40 mode : 27Mbps data rate (worst case) were chosen for full testing.

**Remark:** The field strength of spurious emission was measured in the following position: EUT stand-up position(Z axis), lie-down position(X, Y axis). The worst emission was found in stand-up position(Z axis) and the worst case was recorded.

## 4. TEST METHODOLOGY

The tests documented in this report were performed in accordance with ANSI C63.10:2013 and FCC CFR 47, 15.207, 15.209 and 15.407.

## 5. FACILITIES AND ACCREDITATION

### 5.1 FACILITIES

All measurement facilities used to collect the measurement data are located at

NO. 989-1, Wenshan Rd., Shangshan Village,  
Qionglin Township, Hsinchu County 30741, Taiwan (R.O.C.)

The sites are constructed in conformance with the requirements of ANSI C63.10:2013 and CISPR 22. All receiving equipment conforms to CISPR 16-1-1, CISPR 16-1-2, CISPR 16-1-3, CISPR 16-1-4, CISPR 16-1-5.

### 5.2 ACCREDITATIONS

Our laboratories are accredited and approved by the following approval agencies according to ISO/IEC 17025.

<b>Taiwan</b>	TAF
---------------	-----

The measuring facility of laboratories has been authorized or registered by the following approval agencies.

<b>Canada</b>	INDUSTRY CANADA
<b>Japan</b>	VCCI
<b>Taiwan</b>	BSMI
<b>USA</b>	FCC MRA

Copies of granted accreditation certificates are available for downloading from our web site, <http://www.ccsrf.com>

**5.3 MEASUREMENT UNCERTAINTY**

The following table is for the measurement uncertainty, which is calculated as per the document CISPR 16-4-2.

PARAMETER	UNCERTAINTY
Semi Anechoic Chamber (966 Chamber_C) / Radiated Emission, 30 to 1000 MHz	+/- 3.97
Semi Anechoic Chamber (966 Chamber_C) / Radiated Emission, 1 to 18GHz	+/- 3.58
Semi Anechoic Chamber (966 Chamber_C) / Radiated Emission, 18 to 26 GHz	+/- 3.59
Semi Anechoic Chamber (966 Chamber_C) / Radiated Emission, 26 to 40 GHz	+/- 3.81
Conducted Emission (Mains Terminals), 9kHz to 30MHz	+/- 2.48

This uncertainty represents an expanded uncertainty expressed at approximately the 95% confidence level using a coverage factor of k=2.

Consistent with industry standard (e.g. CISPR 22, clause 11, Measurement Uncertainty) determining compliance with the limits shall be base on the results of the compliance measurement. Consequently the measure emissions being less than the maximum allowed emission result in this be a compliant test or passing test.

The acceptable measurement uncertainty value without requiring revision of the compliance statement is base on conducted and radiated emissions being less than  $U_{CISPR}$  which is 3.6dB and 5.2dB respectively. CCS values (called  $U_{Lab}$  in CISPR 16-4-2) is less than  $U_{CISPR}$  as shown in the table above. Therefore, MU need not be considered for compliance.

## 6. SETUP OF EQUIPMENT UNDER TEST

### SUPPORT EQUIPMENT

No.	Product	Manufacturer	Model No.	Serial No.
1	Notebook PC	HP	ProBook 4421s	CNF03242PJ

No.	Signal Cable Description
1	Non-shielded RJ-45 cable, 12m × 1
2	Non-shielded AC power cable, 2m × 1

### SETUP DIAGRAM FOR TESTS

EUT & peripherals setup diagram is shown in appendix setup photos.

### EUT OPERATING CONDITION

1. EUT & peripherals setup diagram is shown in appendix setup photos.

2. TX Mode:

- ⇒ **Tx Data Rate:** 6Mbps Bandwidth 20 (IEEE 802.11a mode)  
 13Mbps Bandwidth 20 (IEEE 802.11an HT20 mode)  
 27Mbps Bandwidth 40 (IEEE 802.11an HT40 mode)

⇒ **Power control :**

#### **UNII Band 1**

- IEEE 802.11a Channel Low (5180MHz) Chain 1 Power set 17
- IEEE 802.11a Channel Mid (5200MHz) Chain 1 Power set 17
- IEEE 802.11a Channel High (5240MHz) Chain 1 Power set 17
- IEEE 802.11an HT20 Channel Low (5180MHz) Chain 1/2 Power set 17
- IEEE 802.11an HT20 Channel Mid (5200MHz) Chain 1/2 Power set 17
- IEEE 802.11an HT20 Channel High (5240MHz) Chain 1/2 Power set 17
- IEEE 802.11an HT40 Channel Low (5190MHz) Chain 1/2 Power set 13
- IEEE 802.11an HT40 Channel High (5230MHz) Chain 1/2 Power set 17

#### **UNII Band 2A**

- IEEE 802.11a Channel Low (5260MHz) Chain 1 Power set 17
- IEEE 802.11a Channel Mid (5300MHz) Chain 1 Power set 17
- IEEE 802.11a Channel High (5320MHz) Chain 1 Power set 17
- IEEE 802.11an HT20 Channel Low (5260MHz) Chain 1/2 Power set 17
- IEEE 802.11an HT20 Channel Mid (5300MHz) Chain 1/2 Power set 17
- IEEE 802.11an HT20 Channel High (5320MHz) Chain 1/2 Power set 16.5
- IEEE 802.11an HT40 Channel Low (5270MHz) Chain 1/2 Power set 17
- IEEE 802.11an HT40 Channel High (5310MHz) Chain 1/2 Power set 13

**UNII Band 2C**

IEEE 802.11a Channel Low (5500MHz) Chain 1 Power set 17  
IEEE 802.11a Channel Mid (5580MHz) Chain 1 Power set 17  
IEEE 802.11a Channel High (5700MHz) Chain 1 Power set 14  
IEEE 802.11an HT20 Channel Low (5500MHz) Chain 1/2 Power set 15.5  
IEEE 802.11an HT20 Channel Mid (5580MHz) Chain 1/2 Power set 17  
IEEE 802.11an HT20 Channel High (5700MHz) Chain 1/2 Power set 14  
IEEE 802.11an HT40 Channel Low (5510MHz) Chain 1/2 Power set 11.5  
IEEE 802.11an HT40 Channel Mid (5550MHz) Chain 1/2 Power set 17  
IEEE 802.11an HT40 Channel High (5670MHz) Chain 1/2 Power set 16

**UNII Band 3**

IEEE 802.11a Channel Low (5745MHz) Chain 1 Power set 12  
IEEE 802.11a Channel Mid (5785MHz) Chain 1 Power set 17  
IEEE 802.11a Channel High (5825MHz) Chain 1 Power set 15  
IEEE 802.11an HT20 Channel Low (5745MHz) Chain 1/2 Power set 10  
IEEE 802.11an HT20 Channel Mid (5785MHz) Chain 1/2 Power set 17  
IEEE 802.11an HT20 Channel High (5825MHz) Chain 1/2 Power set 13  
IEEE 802.11an HT40 Channel Low (5755MHz) Chain 1/2 Power set 10  
IEEE 802.11an HT40 Channel High (5795MHz) Chain 1/2 Power set 15

3. All of the functions are under run.

4. Start test.

## 7. FCC PART 15.407 REQUIREMENTS

### 7.1 26dB BANDWIDTH

#### LIMITS

§ 15.303 (c), For purposes of this subpart, the emission bandwidth shall be determined by measuring the width of the signal between two points, one below the carrier center frequency and one above the carrier center frequency, that are 26 dB down relative to the maximum level of the modulated carrier. Determination of the emissions bandwidth is based on the use of measurement instrumentation employing a peak detector function with an instrument resolutions bandwidth approximately equal to 1.0 percent of the emission bandwidth of the device under measurement.

#### TEST EQUIPMENT

Name of Equipment	Manufacturer	Model	Serial Number	Calibration Due
EXA Signal Analyzer	Agilent	N9010A	MY52220817	03/19/2016

*Remark: Each piece of equipment is scheduled for calibration once a year.*

#### TEST SETUP



#### TEST PROCEDURE

1. Set RBW = approximately 1% of the emission bandwidth.
2. Set the VBW > RBW.
3. Detector = Peak.
4. Trace mode = max hold.
5. Measure the maximum width of the emission that is 26 dB down from the peak of the emission. Compare this with the RBW setting of the analyzer. Readjust RBW and repeat measurement as needed until the RBW/EBW ratio is approximately 1%.

**TEST RESULTS**

**IEEE 802.11a Mode**

U-NII	Channel	Channel Frequency (MHz)	26dB Bandwidth (MHz)
Band 2A	Low	5260	34.64
	Middle	5300	36.19
	High	5320	35.72
Band 2C	Low	5500	35.85
	Middle	5580	38.23
	High	5700	23.71

**IEEE 802.11an HT20 Mode (Two TX)**

U-NII	Channel	Channel Frequency (MHz)	26dB Bandwidth (MHz)	
			Chain 1	Chain 2
Band 2A	Low	5260	29.05	29.67
	Middle	5280	31.36	33.63
	High	5320	29.13	33.22
Band 2C	Low	5500	30.21	31.85
	Middle	5580	40.00	32.10
	High	5700	20.71	24.18

**IEEE 802.11an HT40 Mode (Two TX)**

U-NII	Channel	Channel Frequency (MHz)	26dB Bandwidth (MHz)	
			Chain 1	Chain 2
Band 2A	Low	5270	65.80	63.96
	High	5310	38.25	38.42
Band 2C	Low	5510	38.15	38.28
	Middle	5550	75.09	75.10
	High	5670	73.18	65.22



**26dB BANDWIDTH**

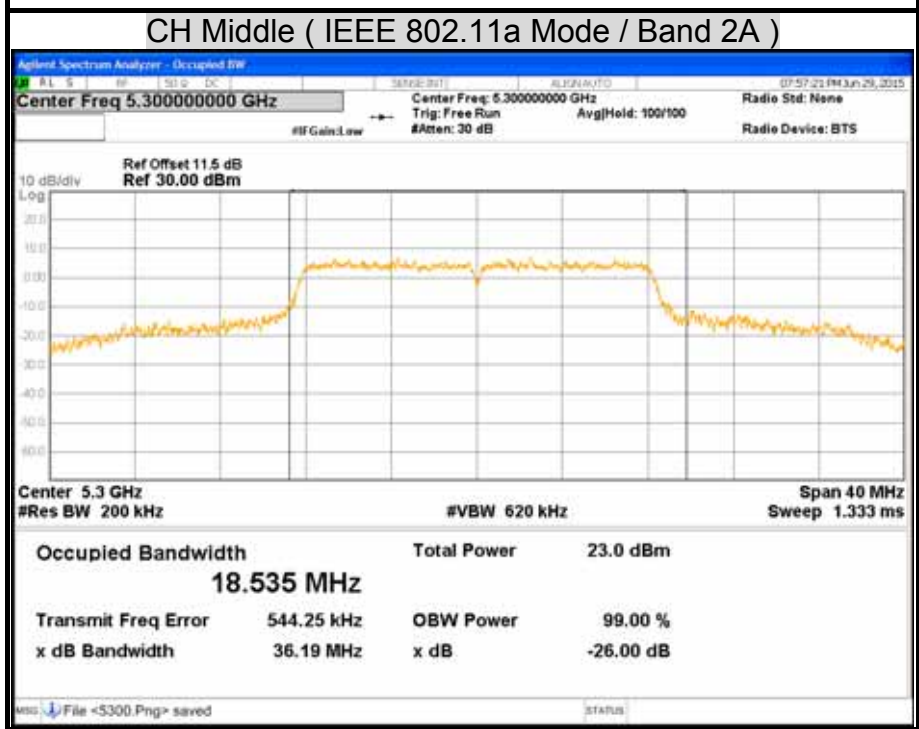
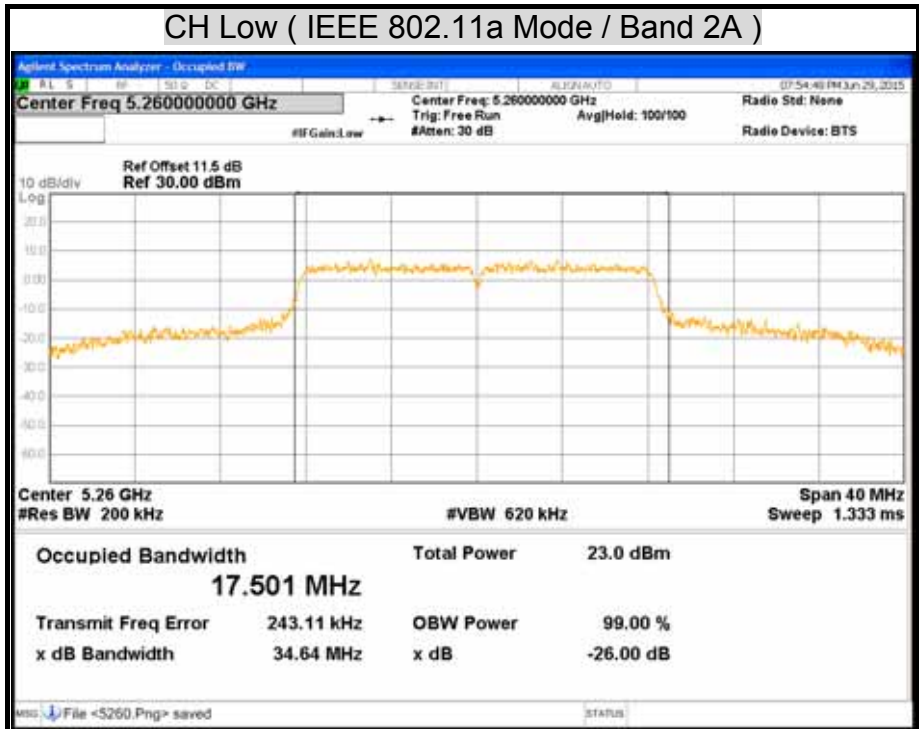

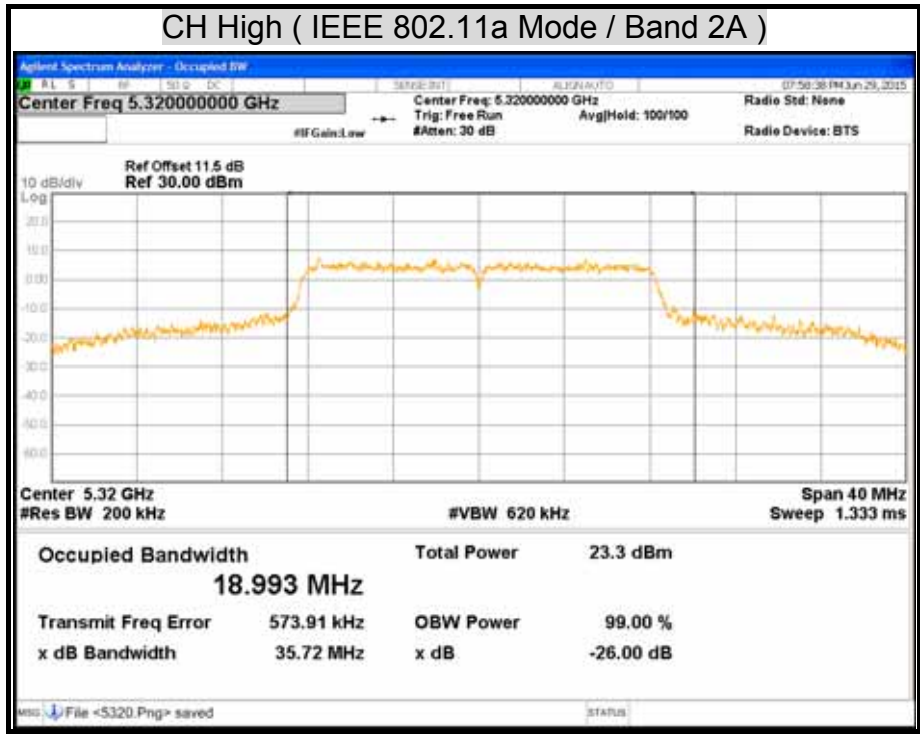

CH Low ( IEEE 802.11a Mode/ Band 2C )

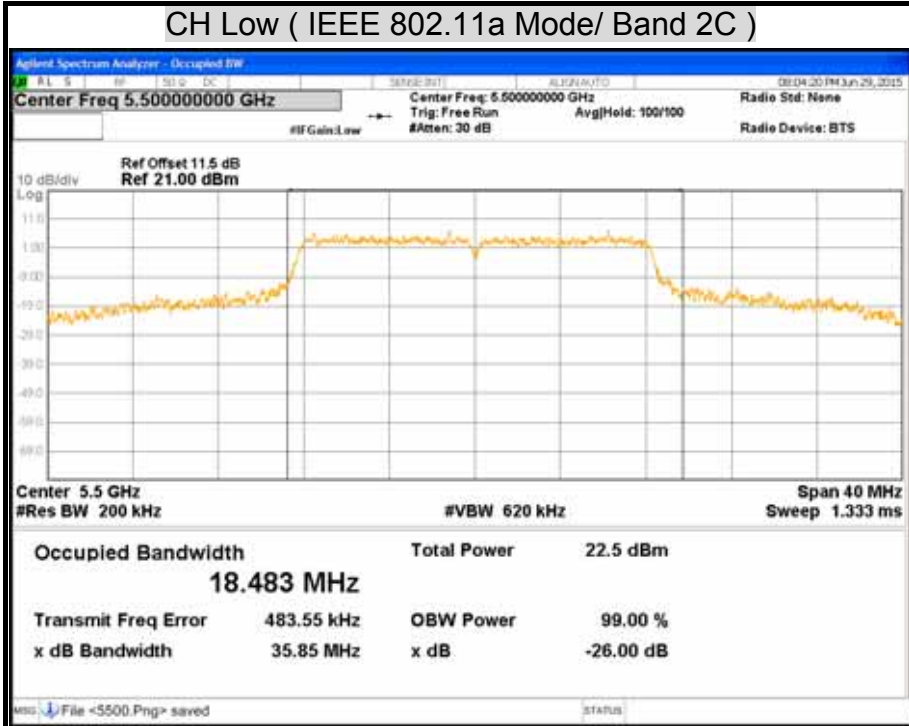

CH Middle ( IEEE 802.11a Mode/ Band 2C )

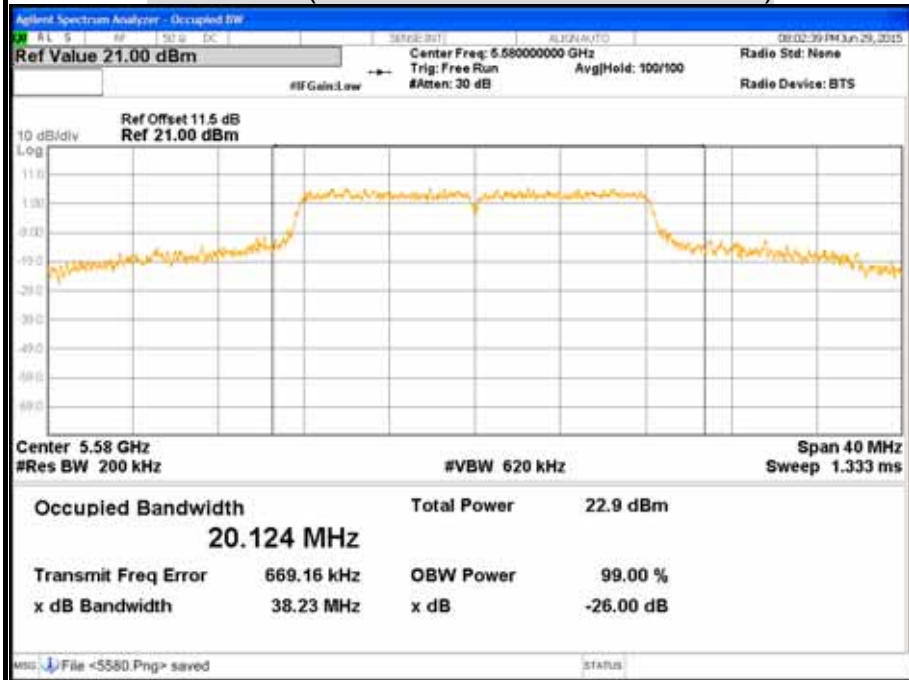

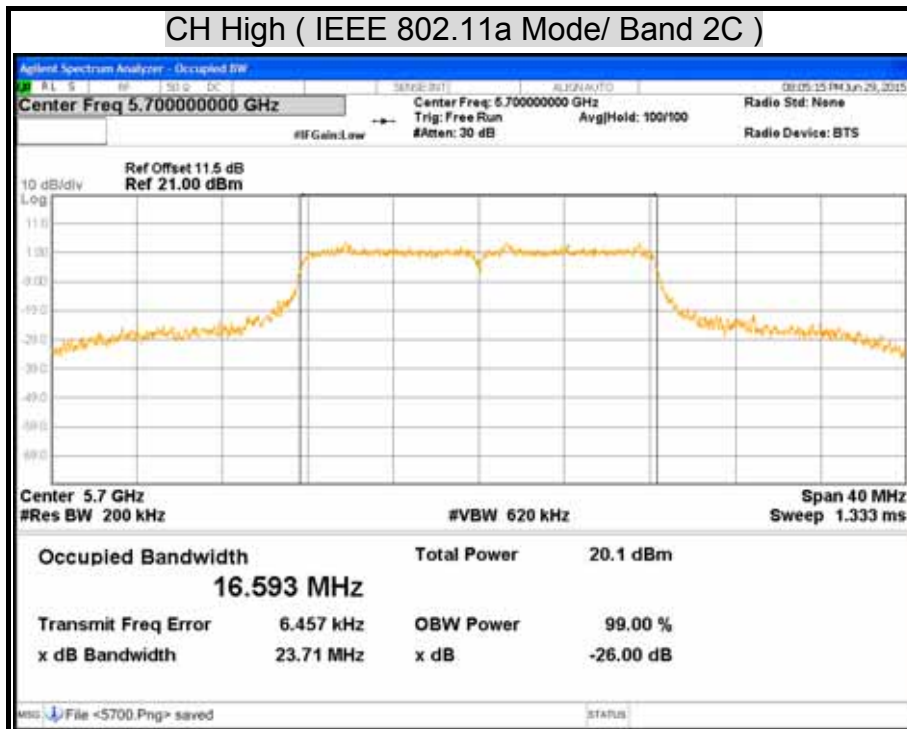

CH Low ( IEEE 802.11an HT20 Mode / Band 2A / Chain 1 )

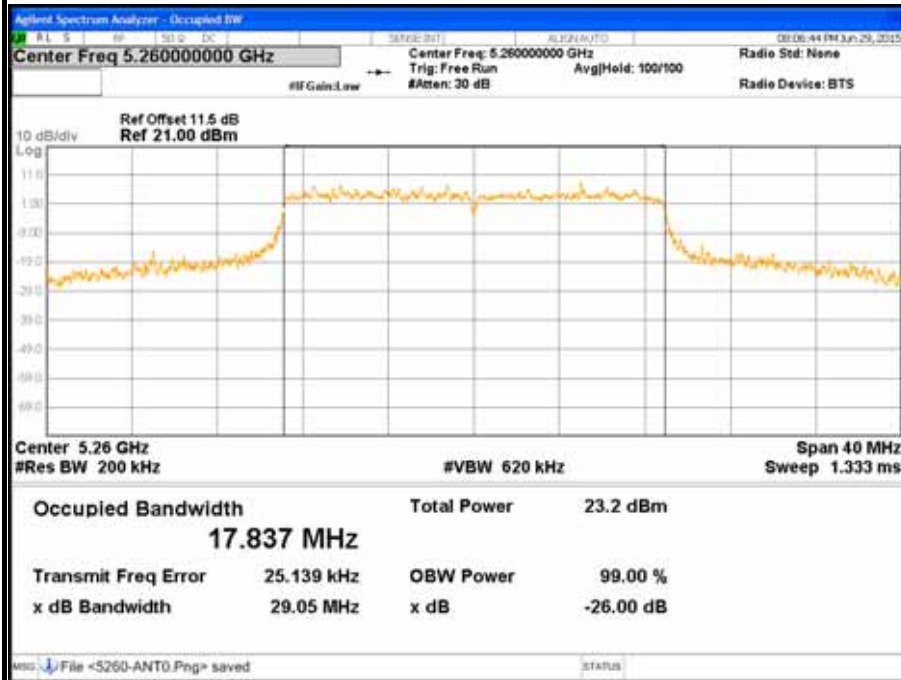

CH Middle ( IEEE 802.11an HT20 Mode / Band 2A / Chain 1 )

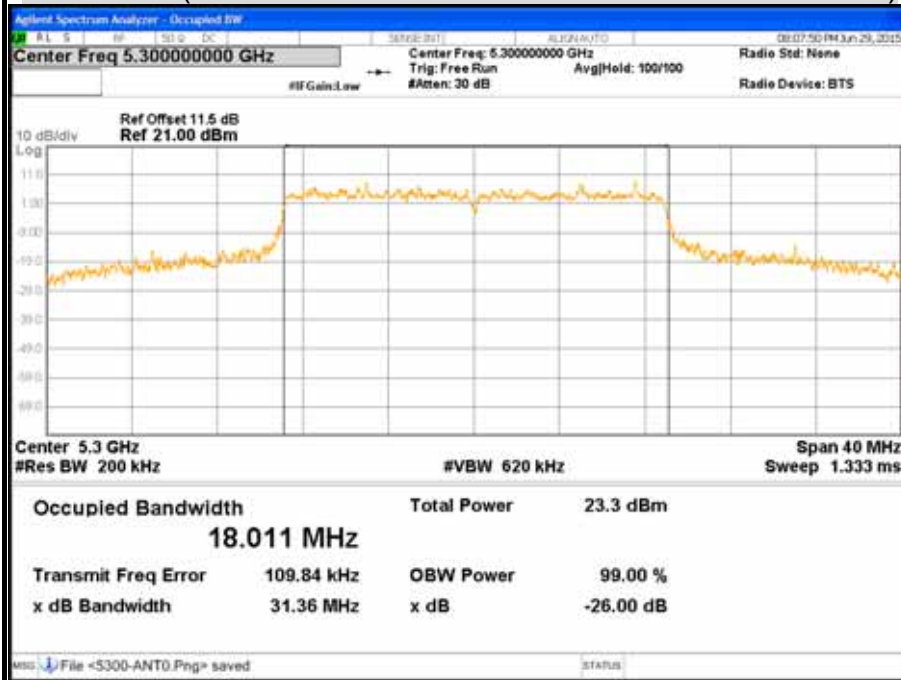

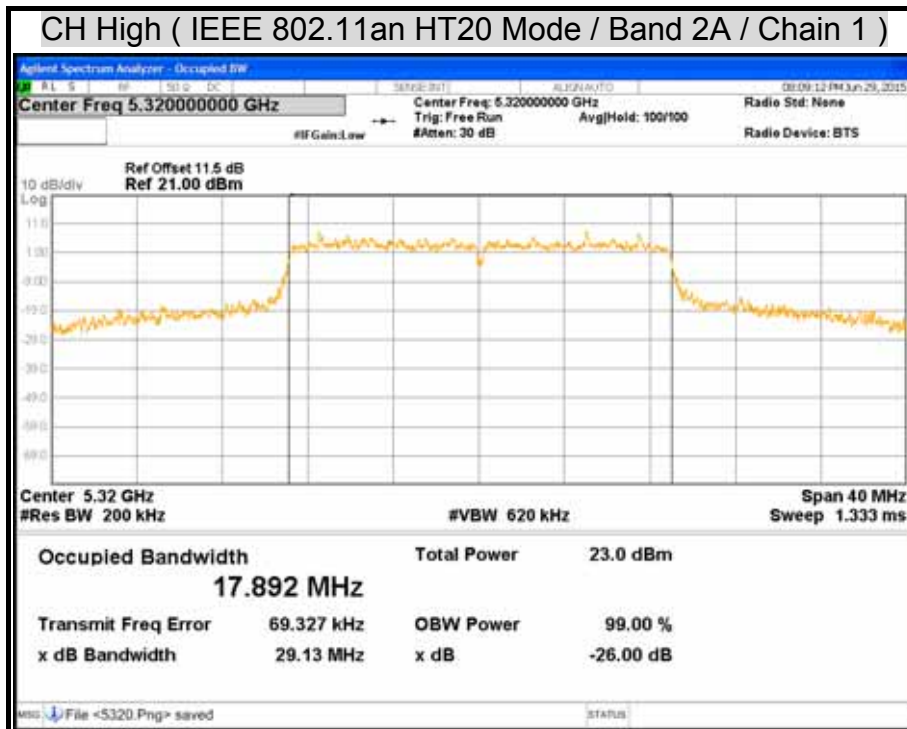

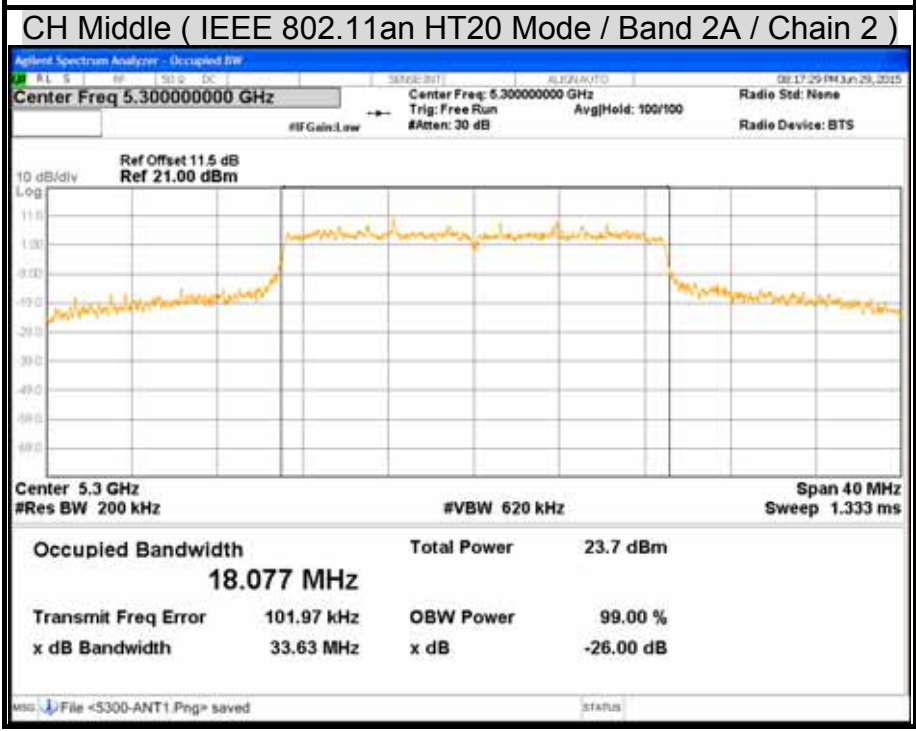
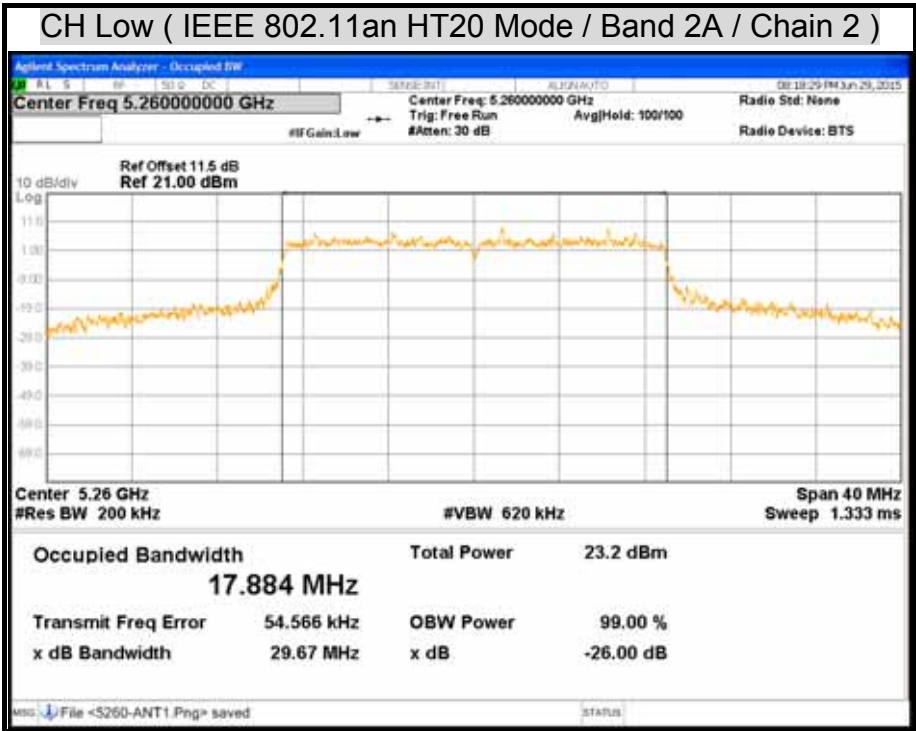

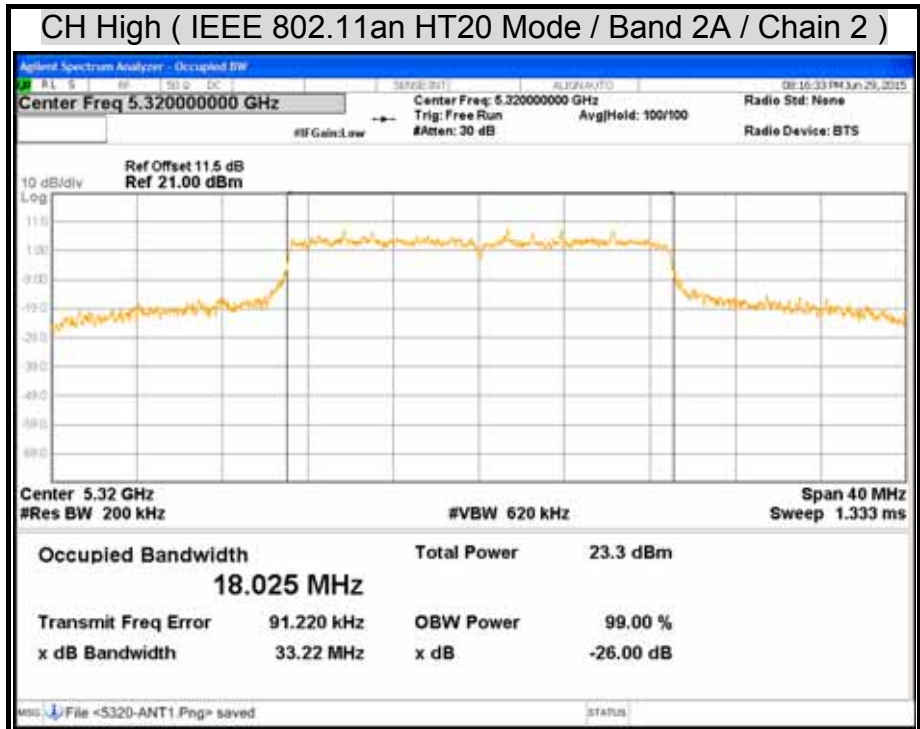



**CH Low ( IEEE 802.11an HT20 Mode / Band 2C / Chain 1 )**

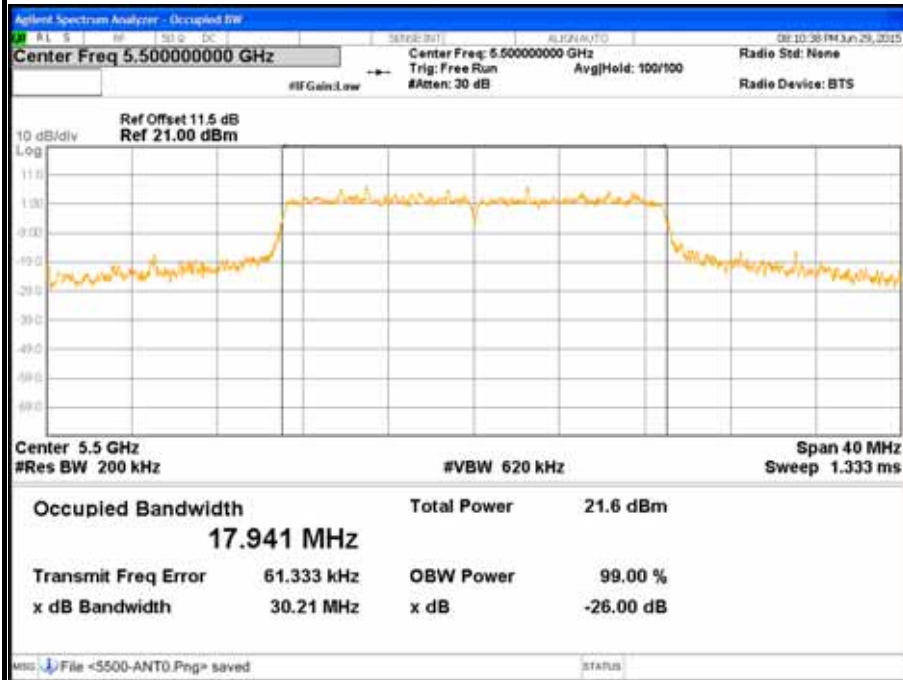

**CH Middle ( IEEE 802.11an HT20 Mode / Band 2C / Chain 1 )**

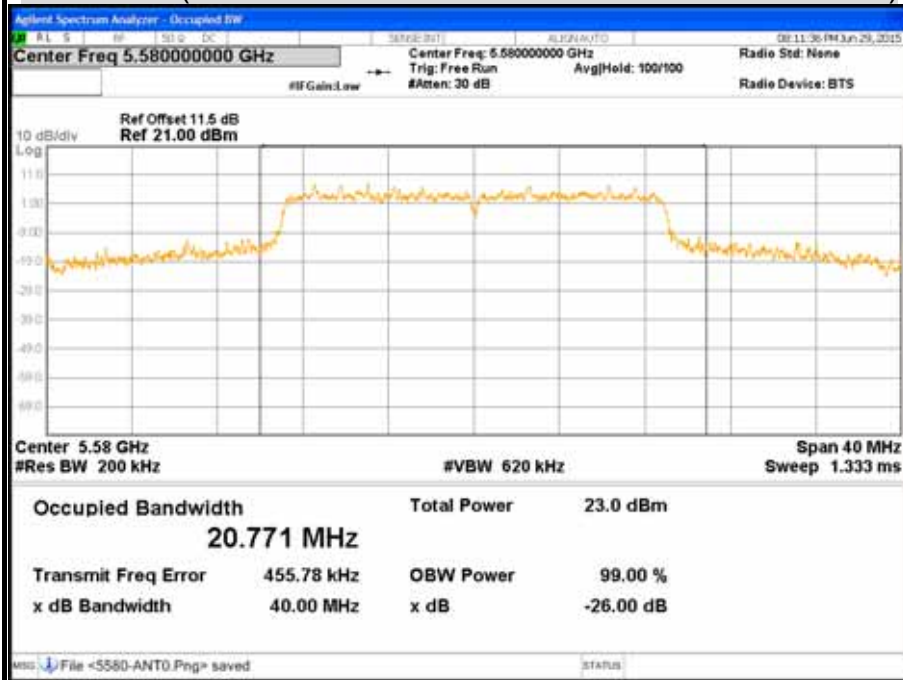

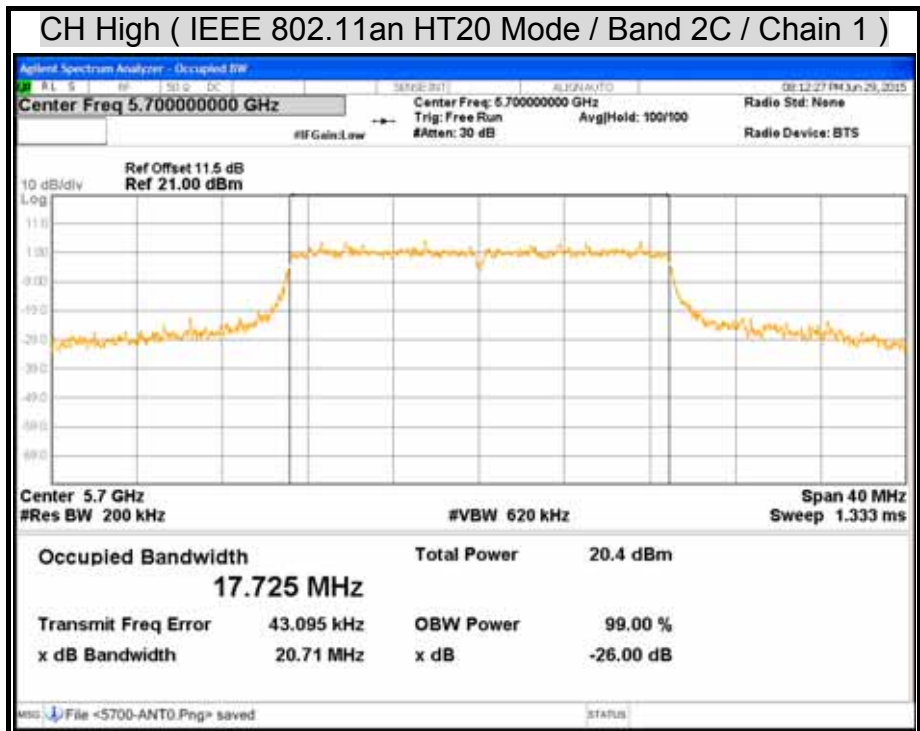

**CH Low ( IEEE 802.11an HT20 Mode / Band 2C / Chain 2 )**

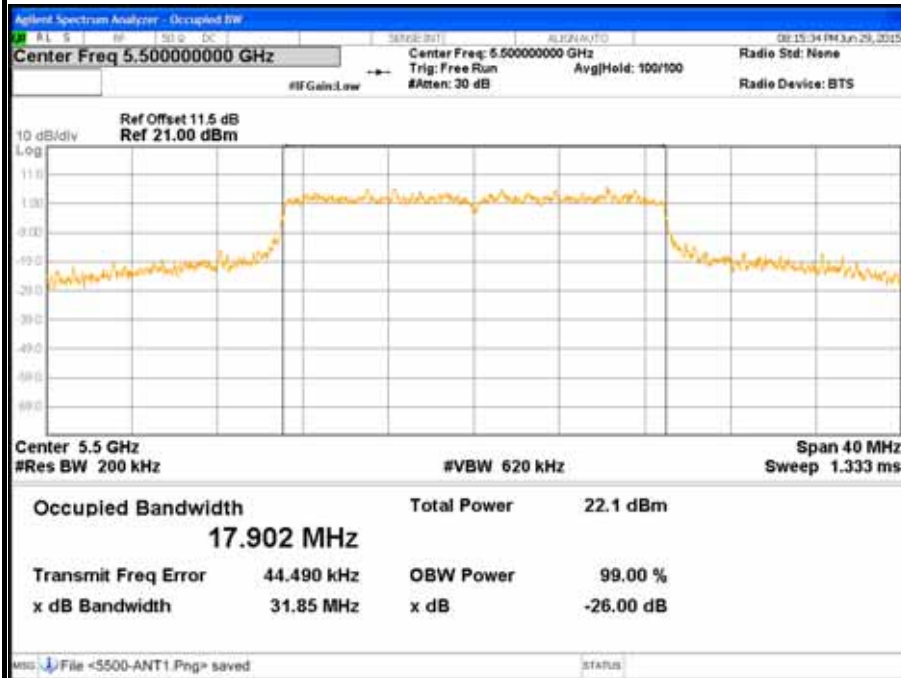

**CH Middle ( IEEE 802.11an HT20 Mode / Band 2C / Chain 2 )**

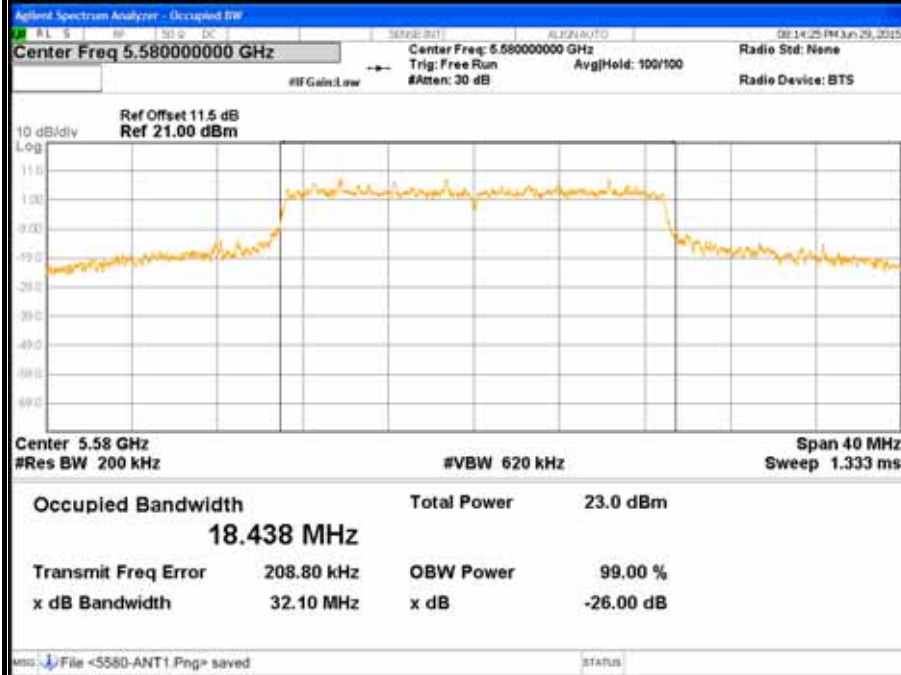

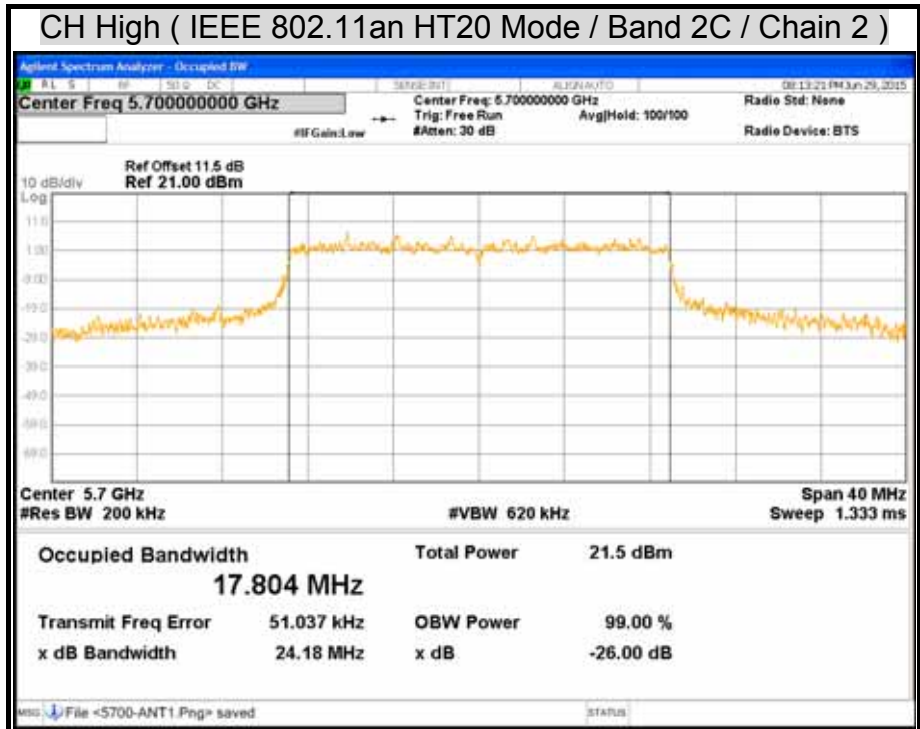

CH Low ( IEEE 802.11an HT40 Mode / Band 2A / Chain 1 )

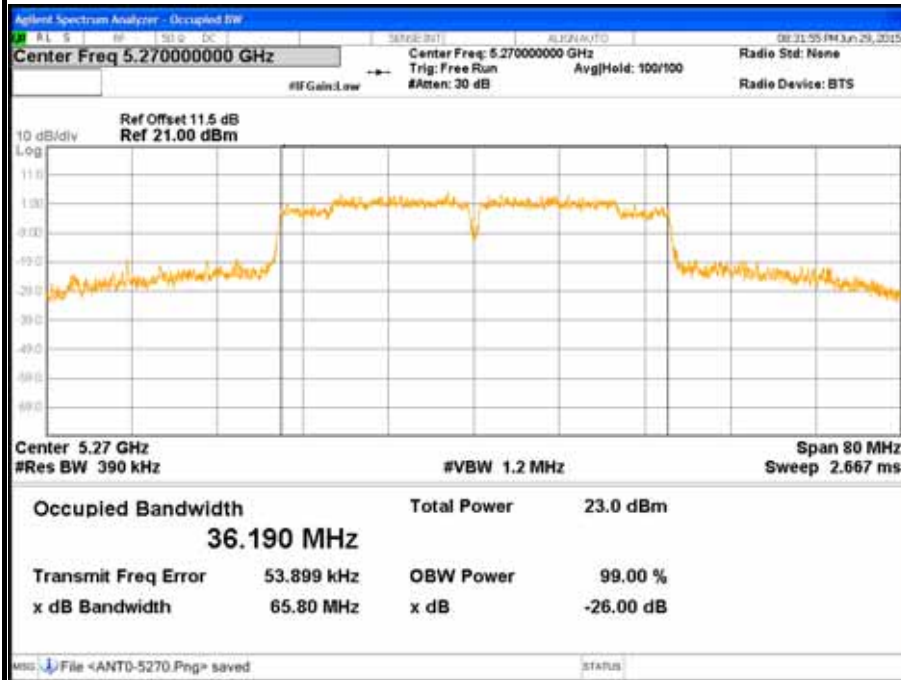

CH High ( IEEE 802.11an HT40 Mode / Band 2A / Chain 1 )

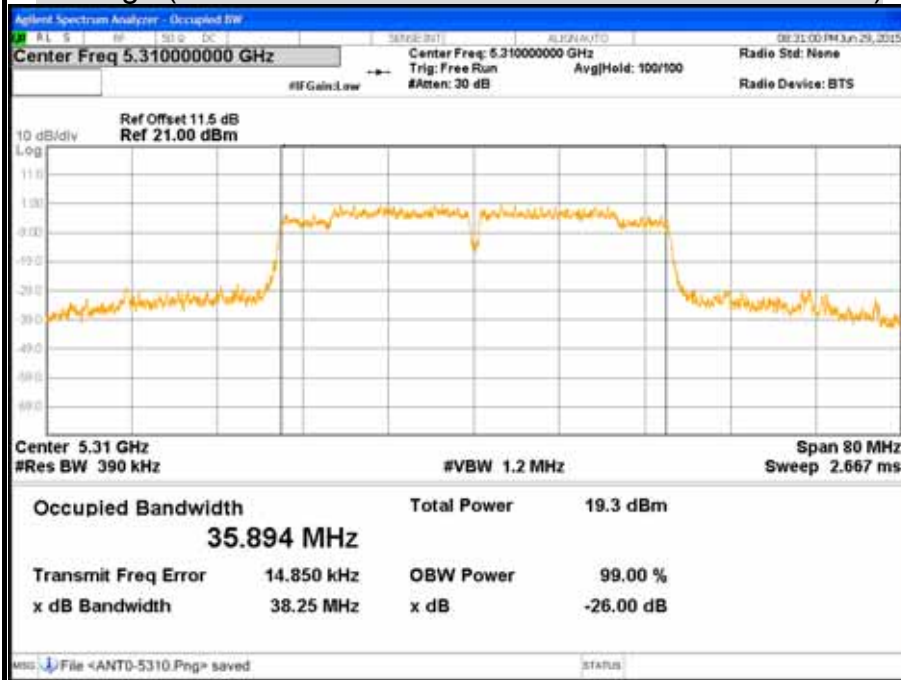

CH Low ( IEEE 802.11an HT40 Mode / Band 2A / Chain 2 )

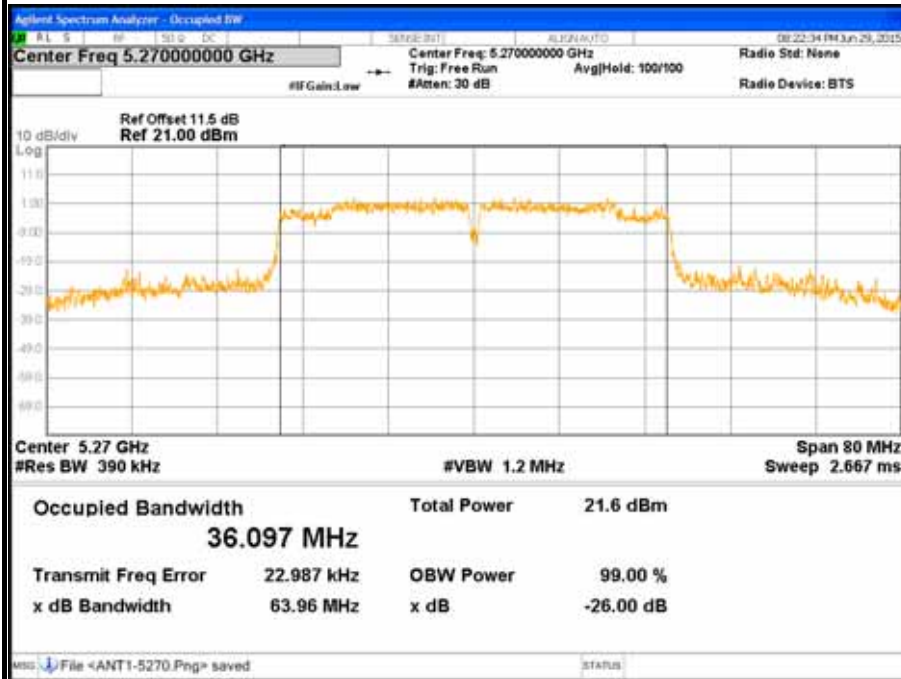

CH High ( IEEE 802.11an HT40 Mode / Band 2A / Chain 2 )

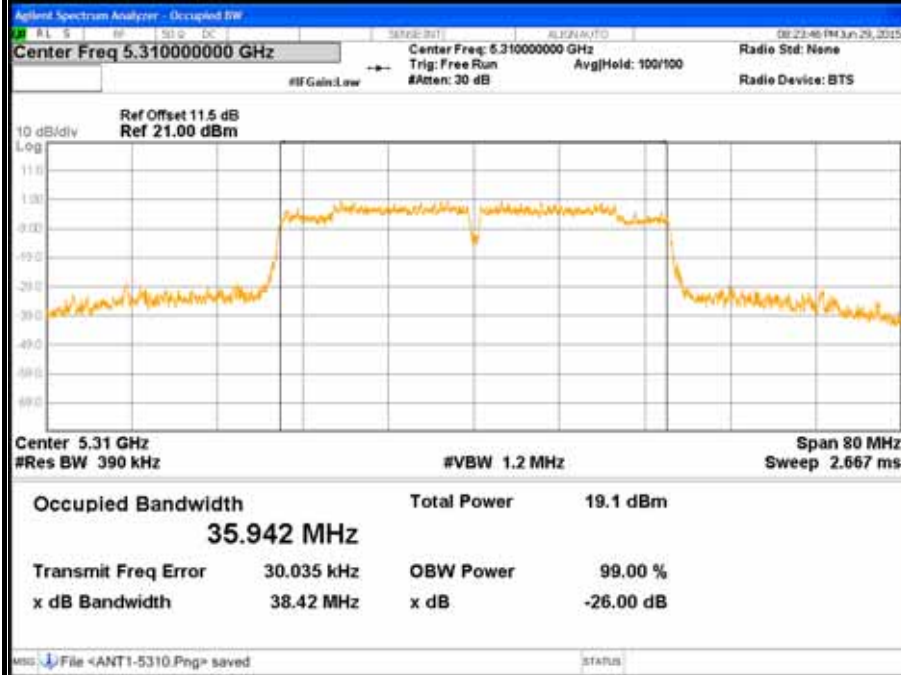

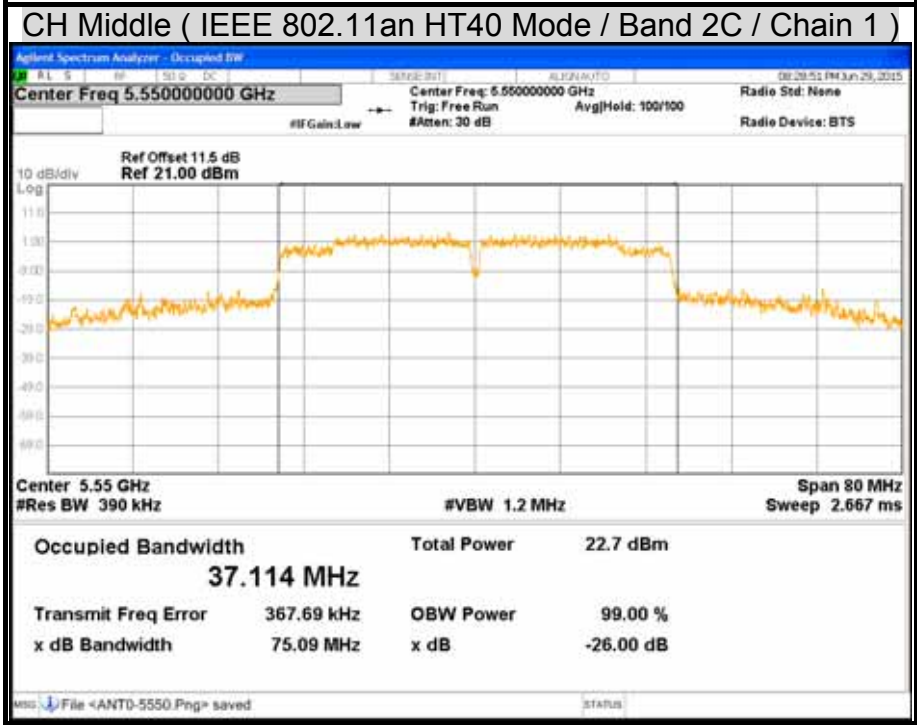
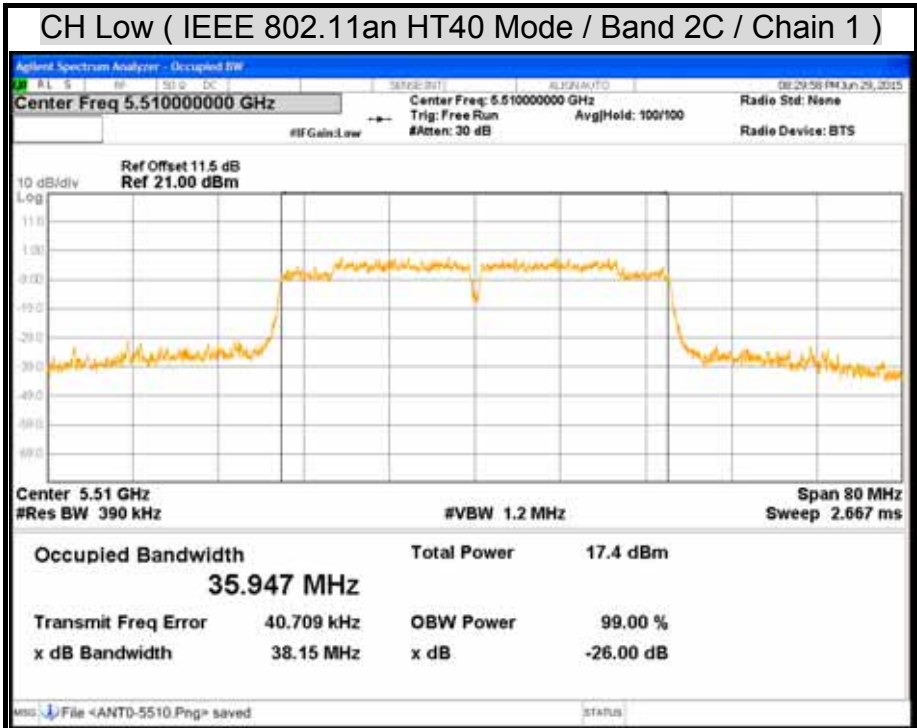

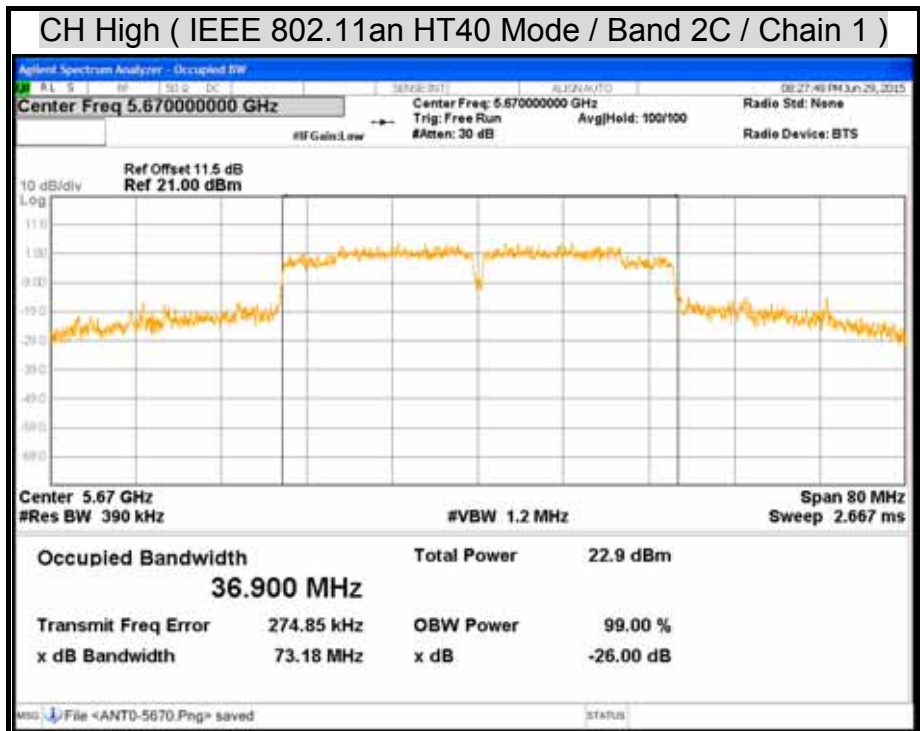



**CH Low ( IEEE 802.11an HT40 Mode / Band 2C / Chain 2 )**

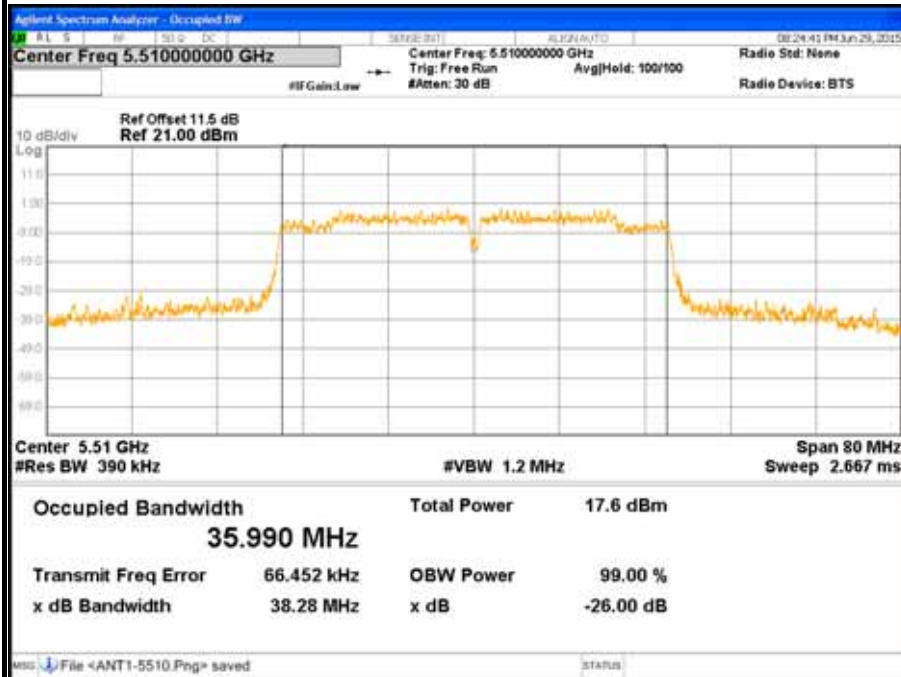

**CH Middle ( IEEE 802.11an HT40 Mode / Band 2C / Chain 2 )**

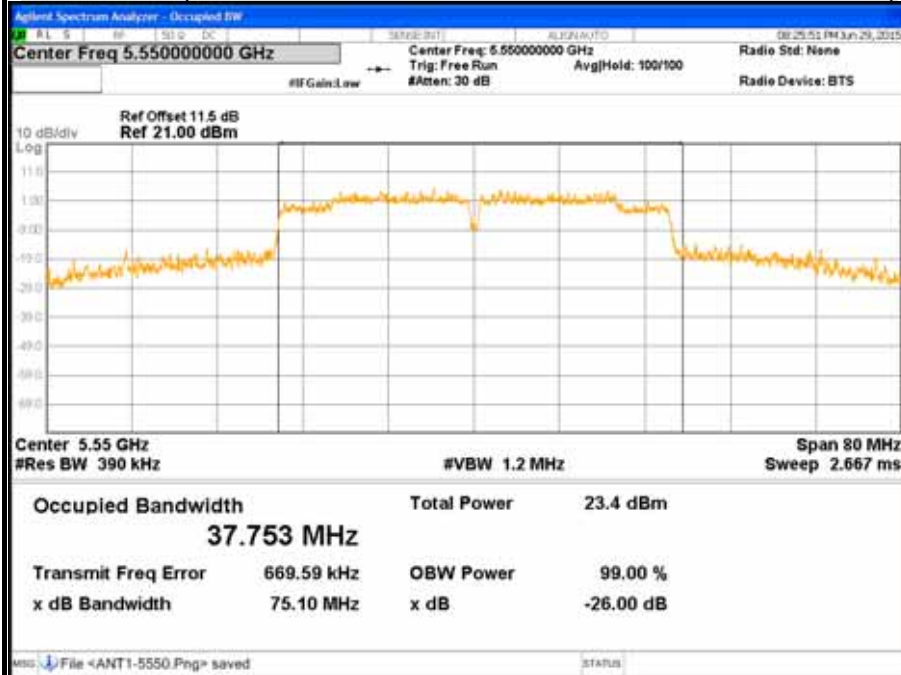

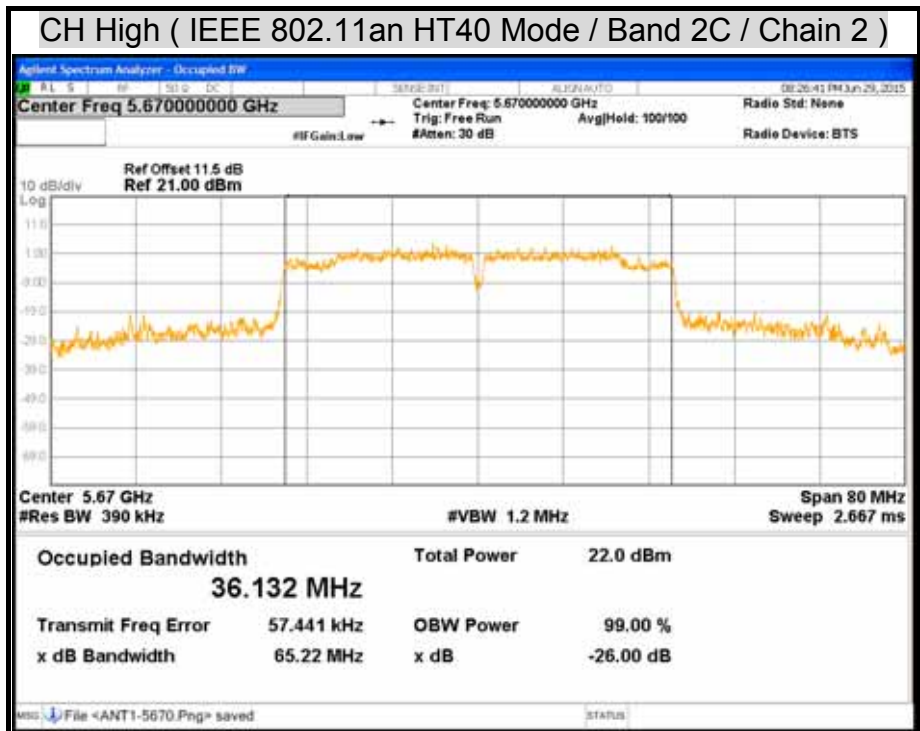

## 7.2 6dB BANDWIDTH

### LIMITS

According to § 15.407 (e), within the 5.725-5.85 GHz band, the minimum 6 dB bandwidth of U-NII devices shall be at least 500 kHz.

### TEST EQUIPMENT

Name of Equipment	Manufacturer	Model	Serial Number	Calibration Due
EXA Signal Analyzer	Agilent	N9010A	MY52220817	03/19/2016

*Remark: Each piece of equipment is scheduled for calibration once a year.*

### TEST SETUP



### TEST PROCEDURE

1. Place the EUT on the table and set it in the transmitting mode.
2. Remove the antenna from the EUT and then connect a low loss RF cable from the antenna port to the spectrum analyzer.
3. Set the spectrum analyzer as RBW = 100kHz, VBW = 300kHz, Sweep = auto.
4. Mark the peak frequency and  $-6$ dB (upper and lower) frequency.
5. Repeat until all the rest channels are investigated.

**TEST RESULTS**

**IEEE 802.11a Mode**

U-NII	Channel	Channel Frequency (MHz)	6dB Bandwidth (MHz)	
			Chain 1	
Band 3	Low	5745	16.36	
	Middle	5785	16.33	
	High	5825	16.38	

**IEEE 802.11an HT20 Mode (Two TX)**

U-NII	Channel	Channel Frequency (MHz)	6dB Bandwidth (MHz)	
			Chain 1	Chain 2
Band 3	Low	5745	17.58	17.54
	Middle	5785	17.55	17.56
	High	5825	17.56	17.42

**IEEE 802.11an HT40 Mode (Two TX)**

U-NII	Channel	Channel Frequency (MHz)	6dB Bandwidth (MHz)	
			Chain 1	Chain 2
Band 3	Low	5755	36.00	35.66
	High	5795	35.88	34.94

**6dB BANDWIDTH**

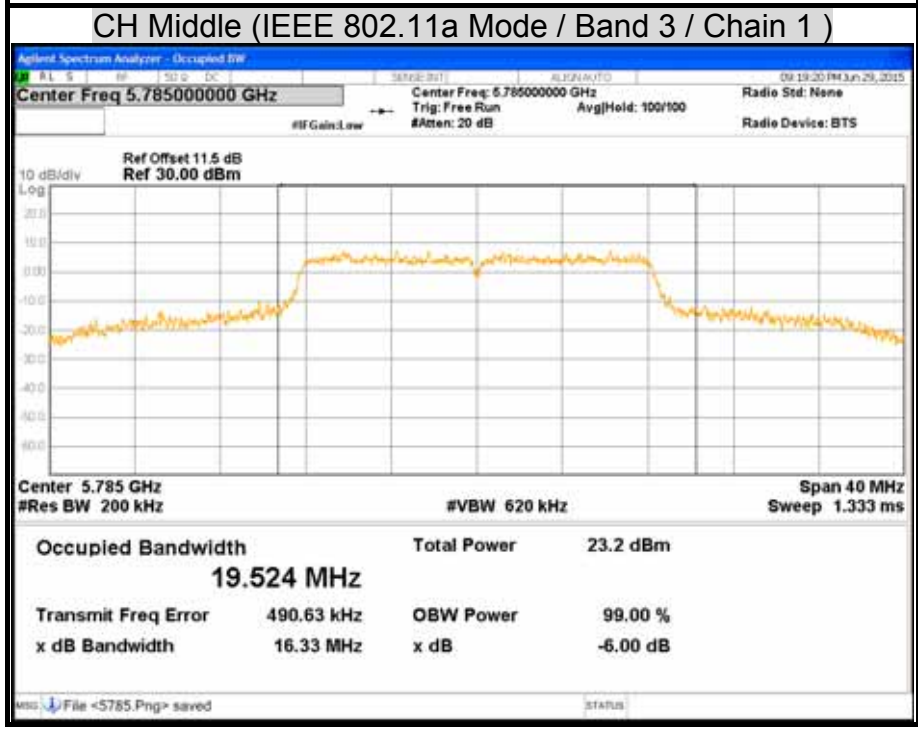
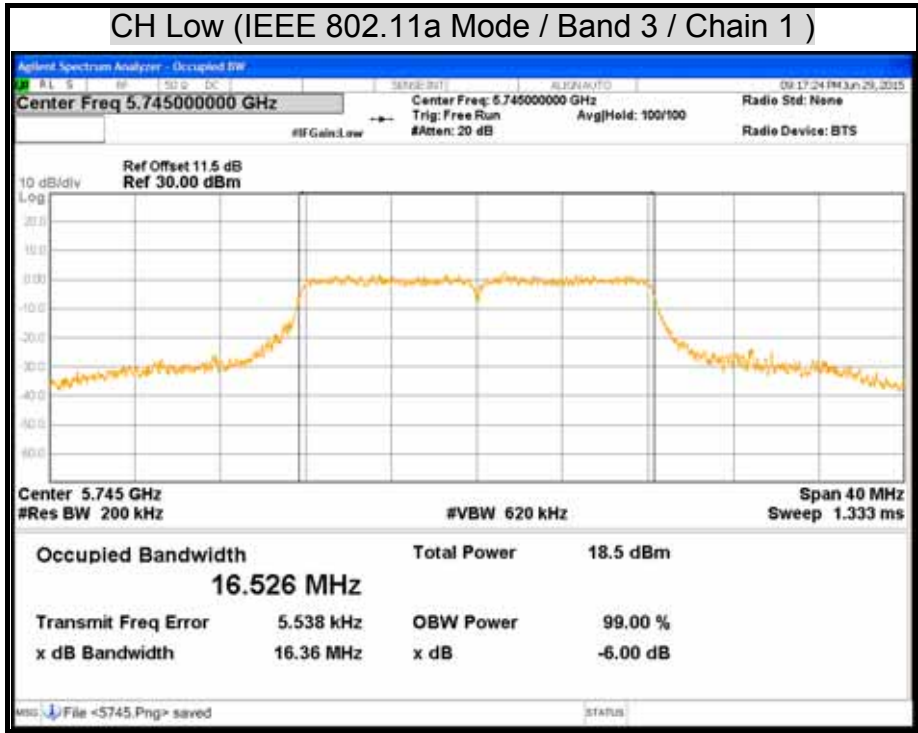

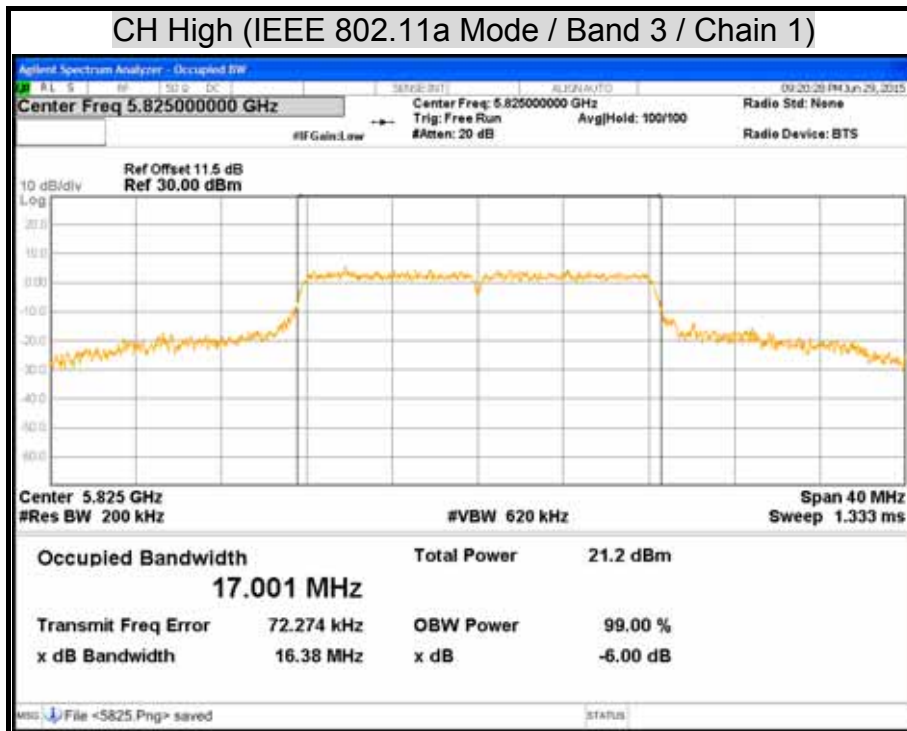

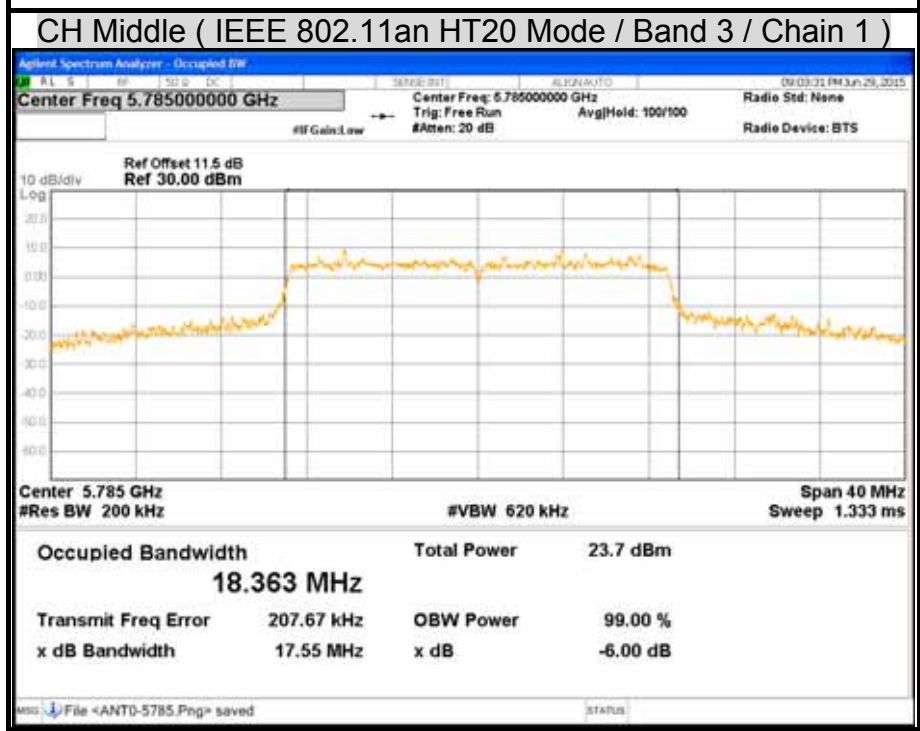
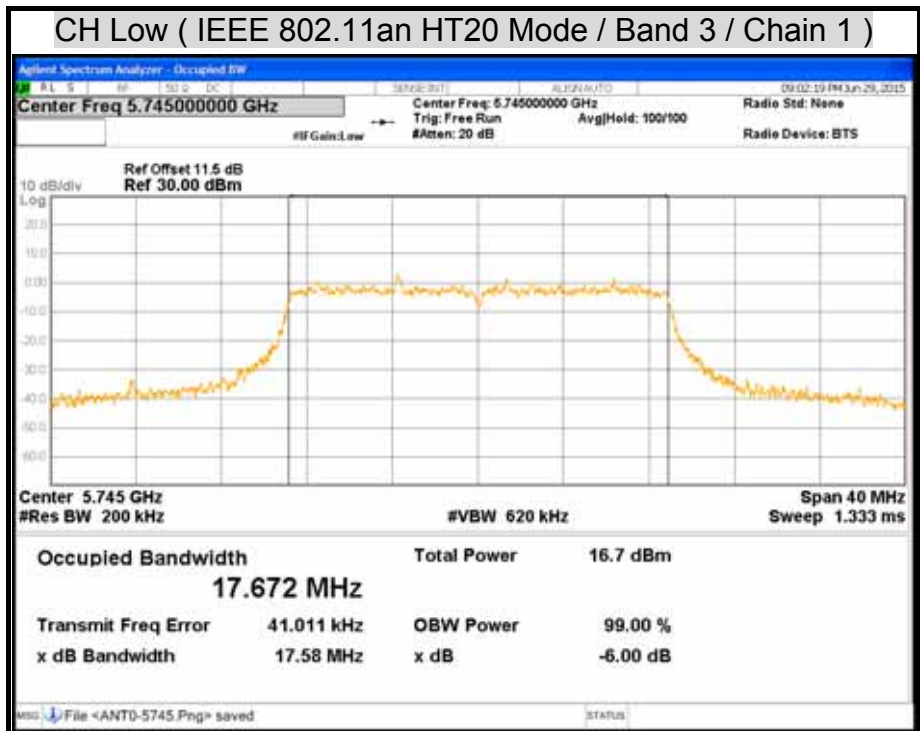

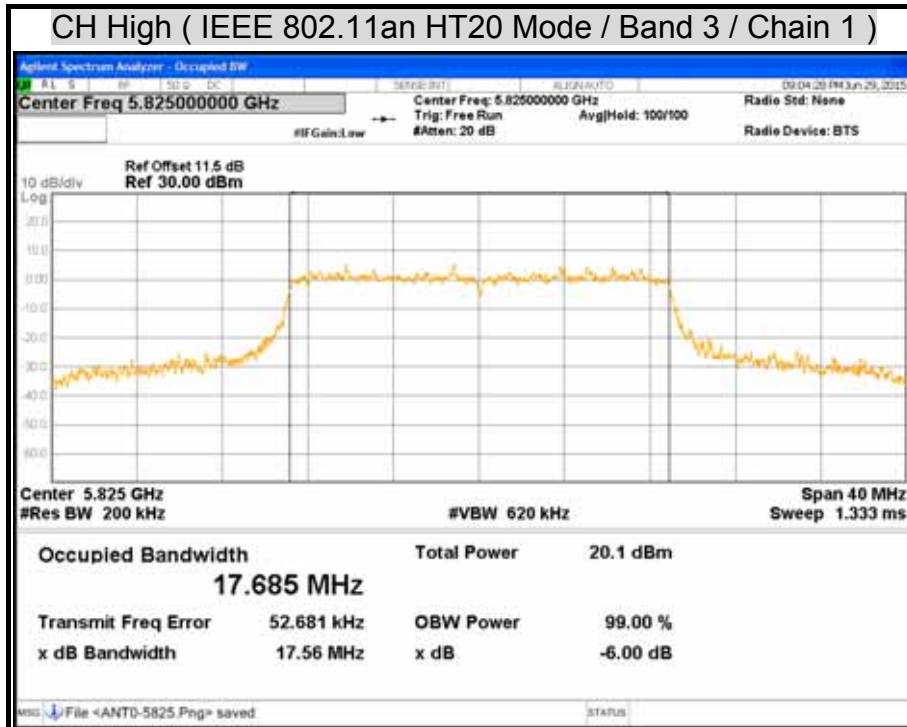



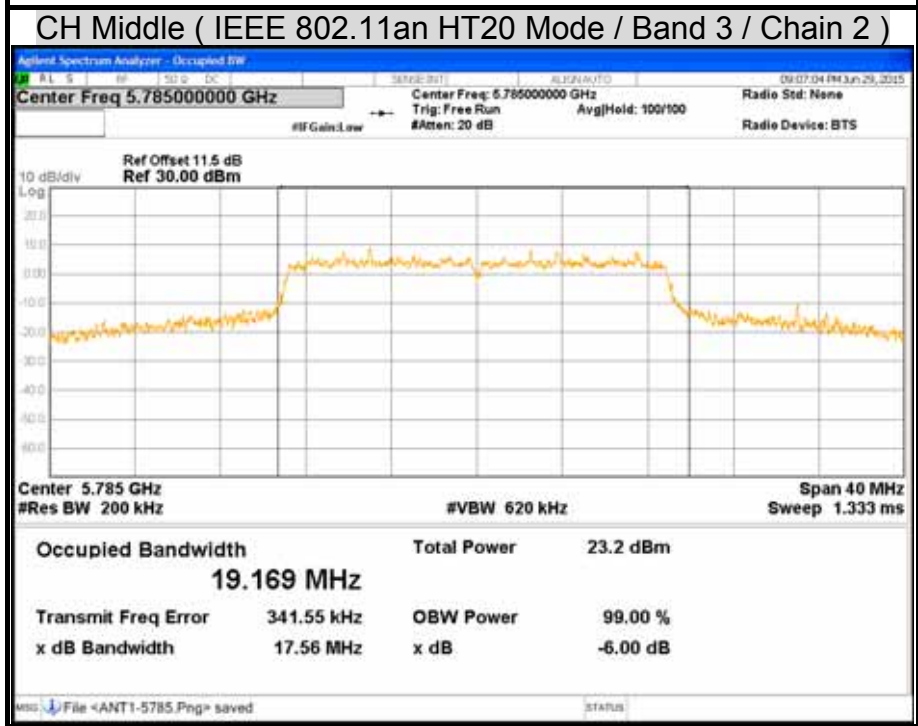
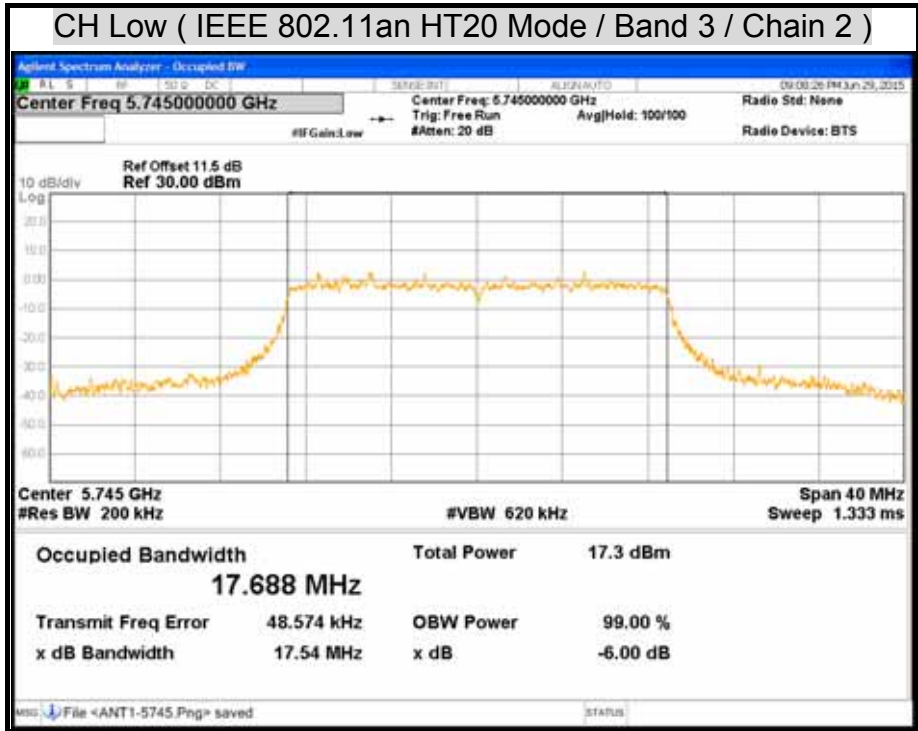

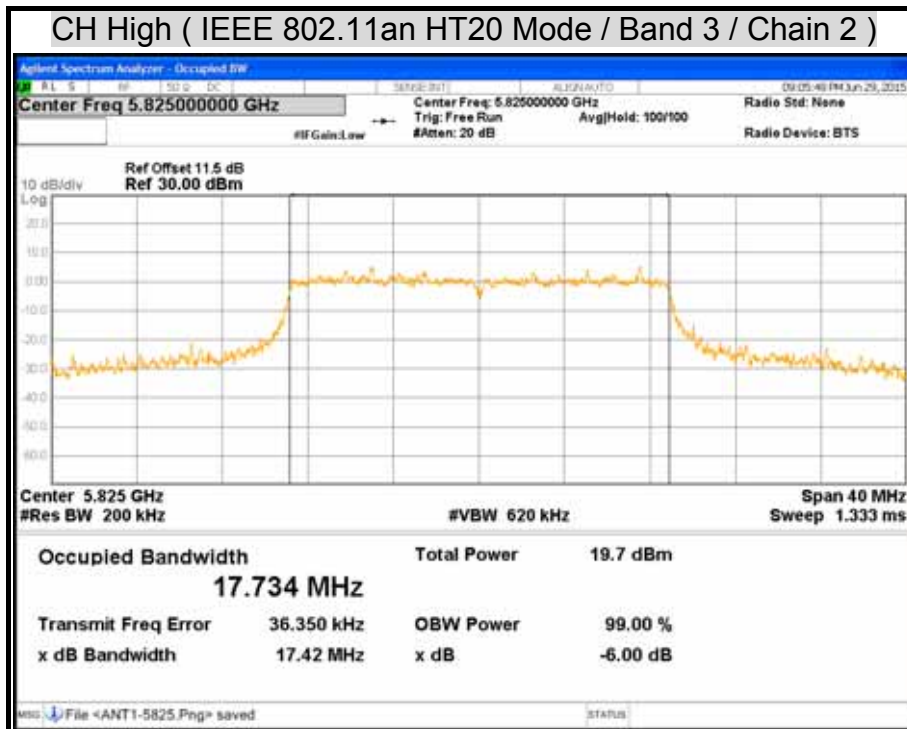

CH Low ( IEEE 802.11an HT40 Mode / Band 3 / Chain 1 )

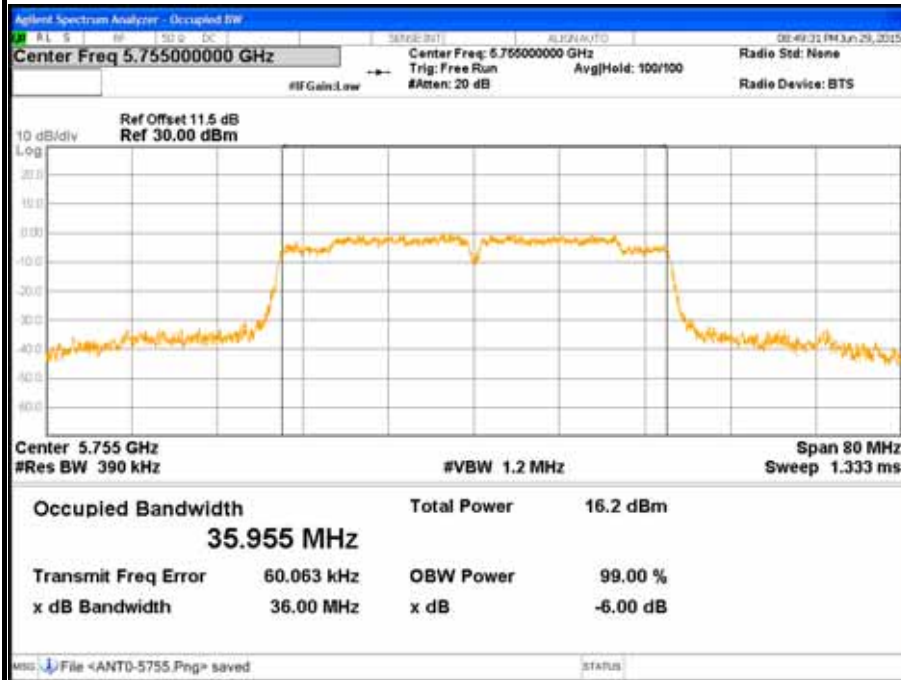

CH High ( IEEE 802.11an HT40 Mode / Band 3 / Chain 1 )

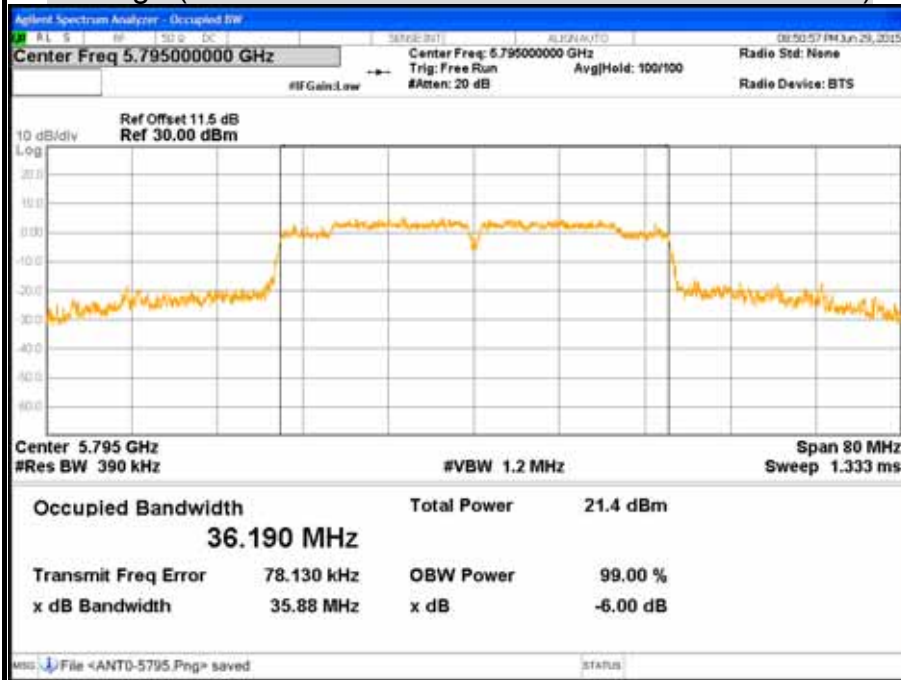

**CH Low ( IEEE 802.11an HT40 Mode / Band 3 / Chain 2 )**

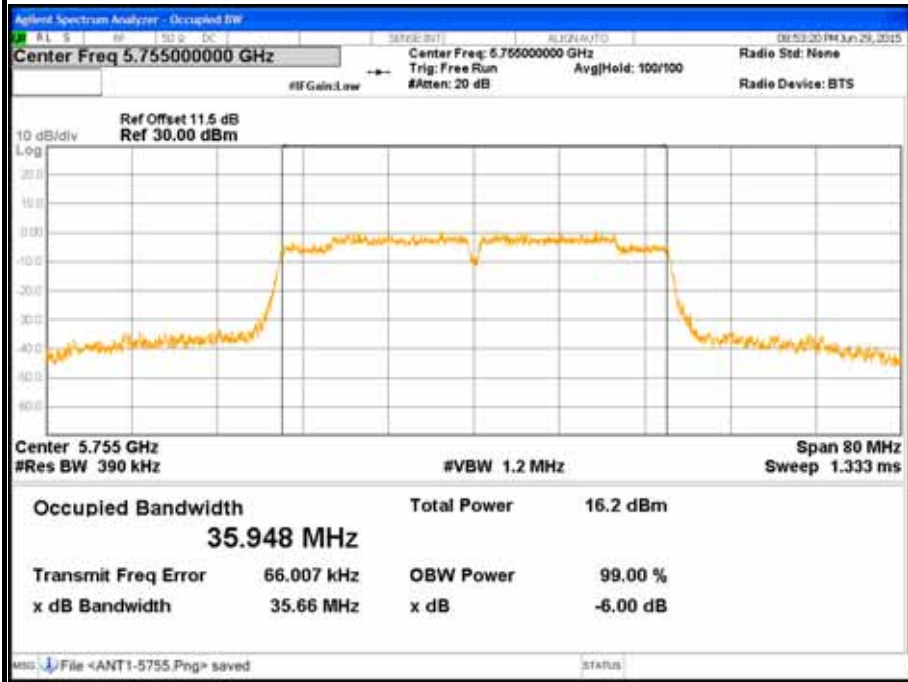

**CH High ( IEEE 802.11an HT40 Mode / Band 3 / Chain 2 )**

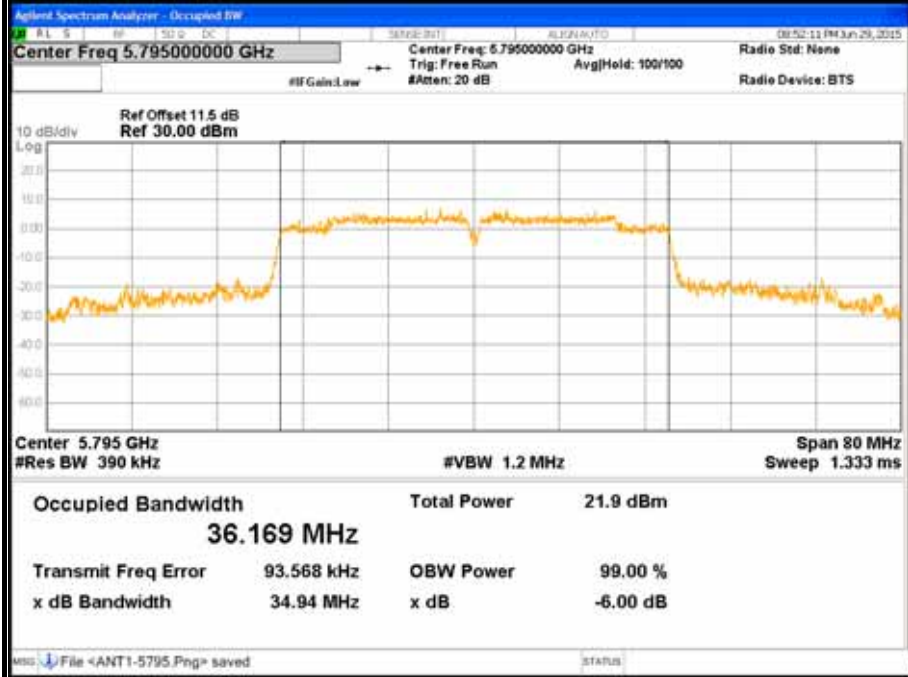

## 7.2 MAXIMUM CONDUCTED OUTPUT POWER

### LIMITS

#### § 15.407(a)

(1) For the band 5.15-5.25 GHz,

(I) For an outdoor access point operating in the band 5.15-5.25 GHz, the maximum conducted output power over the frequency band of operation shall not exceed 1W provided the maximum antenna gain does not exceed 6 dBi. In addition, the maximum power spectral density shall not exceed 17 dBm in any 1 megahertz band. If transmitting antennas of directional gain greater than 6 dBi are used, both the maximum conducted output power and the maximum power spectral density shall be reduced by the amount in dB that the directional gain of the antenna exceeds 6 dBi. The maximum e.i.r.p. at any elevation angle above 30 degrees as measured from the horizon must not exceed 125 mW (21 dBm).

(II) For an indoor access point operating in the band 5.15-5.25 GHz, the maximum conducted output power over the frequency band of operation shall not exceed 1W provided the maximum antenna gain does not exceed 6 dBi. In addition, the maximum power spectral density shall not exceed 17dBm in any 1 megahertz band. If transmitting antennas of directional gain greater than 6dBi are used, both the maximum conducted output power and the maximum power spectral density shall be reduced by the amount in dB that the directional gain of the antenna exceeds 6dBi.

(III) For fixed point-to-point access points operating in the band 5.15-5.25 GHz, the maximum conducted output power over the frequency band of operation shall not exceed 1 W. Fixed point-to-point U-NII devices may employ antennas with directional gain up to 23 dBi without any corresponding reduction in the maximum conducted output power or maximum power spectral density. For fixed point-to-point transmitters that employ a directional antenna gain greater than 23 dBi, a 1 dB reduction in maximum conducted output power and maximum power spectral density is required for each 1 dB of antenna gain in excess of 23 dBi. Fixed, point-to-point operations exclude the use of point-to-multipoint systems, omnidirectional applications, and multiple collocated transmitters transmitting the same information. The operator of the U-NII device, or if the equipment is professionally installed, the installer, is responsible for ensuring that systems employing high gain directional antennas are used exclusively for fixed, point-to-point operations.

- (IV) For mobile and portable client devices in the 5.15-5.25 GHz band, the maximum conducted output power over the frequency band of operation shall not exceed 250 mW provided the maximum antenna gain does not exceed 6 dBi. In addition, the maximum power spectral density shall not exceed 11 dBm in any 1 megahertz band. If transmitting antennas of directional gain greater than 6 dBi are used, both the maximum conducted output power and the maximum power spectral density shall be reduced by the amount in dB that the directional gain of the antenna exceeds 6 dBi.
- (2) For the 5.25-5.35 GHz and 5.47-5.725 GHz bands, the maximum conducted output power over the frequency bands of operation shall not exceed the lesser of 250 mW or 11 dBm  $10 \log B$ , where B is the 26 dB emission bandwidth in megahertz. In addition, the maximum power spectral density shall not exceed 11 dBm in any 1 megahertz band. If transmitting antennas of directional gain greater than 6 dBi are used, both the maximum conducted output power and the maximum power spectral density shall be reduced by the amount in dB that the directional gain of the antenna exceeds 6 dBi.
- (3) For the band 5.725-5.85 GHz, the maximum conducted output power over the frequency band of operation shall not exceed 1 W. In addition, the maximum power spectral density shall not exceed 30 dBm in any 500-kHz band. If transmitting antennas of directional gain greater than 6 dBi are used, both the maximum conducted output power and the maximum power spectral density shall be reduced by the amount in dB that the directional gain of the antenna exceeds 6 dBi. However, fixed point-to-point U-NII devices operating in this band may employ transmitting antennas with directional gain greater than 6 dBi without any corresponding reduction in transmitter conducted power. Fixed, point-to-point operations exclude the use of point-to-multipoint systems, omnidirectional applications, and multiple collocated transmitters transmitting the same information. The operator of the U-NII device, or if the equipment is professionally installed, the installer, is responsible for ensuring that systems employing high gain directional antennas are used exclusively for fixed, point-to-point operations.

§ KDB 662911 : For power measurements on IEEE 802.11 devices

Array Gain = 0 dB (i.e., no array gain) for  $N_{ANT} \leq 4$  ;

Array Gain = 0 dB (i.e., no array gain) for channel widths  $\geq 40$  MHz for any  $N_{ANT}$  ;

Array Gain =  $5 \log(N_{ANT}/N_{SS})$  dB or 3 dB, whichever is less for 20-MHz channel widths with  $N_{ANT} \geq 5$ .

**TEST EQUIPMENT**

Name of Equipment	Manufacturer	Model	Serial Number	Calibration Due
Power Meter	ANRITSU	ML2495A	1149001	12/11/2015
Power Sensor	ANRITSU	MA2411B	1126148	12/11/2015

*Remark: Each piece of equipment is scheduled for calibration once a year.*

**TEST SETUP****TEST PROCEDURE**

The transmitter output is connected to the power meter. The power meter is set to the power detection.

**TEST RESULTS**

The power shall not exceeded the limit as follows:

**IEEE 802.11a Mode / UNII Band 2A**

Channel	Channel Frequency (MHz)	26dB Bandwidth (B) (MHz)	10 Log B (dB)	11dBm + 10 Log B (dBm)	Maximum Conducted Output Power Limit (dBm)
Low	5260	34.64	15.40	26.40	24
Middle	5280	36.19	15.59	26.59	24
High	5320	35.72	15.53	26.53	24

**IEEE 802.11a Mode / UNII Band 2C**

Channel	Channel Frequency (MHz)	26dB Bandwidth (B) (MHz)	10 Log B (dB)	11dBm + 10 Log B (dBm)	Maximum Conducted Output Power Limit (dBm)
Low	5500	35.85	15.54	26.54	24
Middle	5580	38.23	15.82	26.82	24
High	5700	23.71	13.75	24.75	24

**IEEE 802.11an HT20 Mode/ UNII Band 2A (Two TX)**

Channel	Channel Frequency (MHz)	26dB Bandwidth (B) (MHz)		10 Log B (dB)		11dBm + 10 Log B (dBm)		Maximum Conducted Output Power Limit (dBm)
		Chain 1	Chain 2	Chain 1	Chain 2	Chain 1	Chain 2	
Low	5260	29.05	29.67	14.63	14.72	25.63	25.72	24
Middle	5280	31.36	33.63	14.96	15.27	25.96	26.27	24
High	5320	29.13	33.22	14.64	15.21	25.64	26.21	24



**IEEE 802.11an HT20 Mode/ UNII Band 2C (Two TX)**

Channel	Channel Frequency (MHz)	26dB Bandwidth (B) (MHz)		10 Log B (dB)		11dBm + 10 Log B (dBm)		Maximum Conducted Output Power Limit (dBm)
		Chain 1	Chain 2	Chain 1	Chain 2	Chain 1	Chain 2	
Low	5500	30.21	31.85	14.80	15.03	25.80	26.03	24
Middle	5580	40.00	32.10	16.02	15.07	27.02	26.07	24
High	5700	20.71	24.18	13.16	13.83	24.16	24.83	24

**IEEE 802.11an HT40 Mode/ UNII Band 2A (Two TX)**

Channel	Channel Frequency (MHz)	26dB Bandwidth (B) (MHz)		10 Log B (dB)		11dBm + 10 Log B (dBm)		Maximum Conducted Output Power Limit (dBm)
		Chain 1	Chain 2	Chain 1	Chain 2	Chain 1	Chain 2	
Low	5270	65.80	63.96	18.18	18.06	29.18	29.06	24
High	5310	38.25	38.42	15.83	15.85	26.83	26.85	24

**IEEE 802.11an HT40 Mode/ UNII Band 2C (Two TX)**

Channel	Channel Frequency (MHz)	26dB Bandwidth (B) (MHz)		10 Log B (dB)		11dBm + 10 Log B (dBm)		Maximum Conducted Output Power Limit (dBm)
		Chain 1	Chain 2	Chain 1	Chain 2	Chain 1	Chain 2	
Low	5510	38.15	38.28	15.81	15.83	26.81	26.83	24
Middle	5550	75.09	75.10	18.76	18.76	29.76	29.76	24
High	5670	73.18	65.22	18.64	18.14	29.64	29.14	24

**IEEE 802.11a Mode / UNII Band 1**

Channel	Channel Frequency (MHz)	Power		Power Limit		Pass / Fail
		(dBm)	(W)	(dBm)	(W)	
Low	5180	17.14	0.0518	24	0.25	PASS
Middle	5220	17.35	0.0543	24	0.25	PASS
High	5240	17.36	0.0544	24	0.25	PASS

**Remark:**

1. At final test to get the worst-case emission at 6 Mbps.
2. The cable assembly insertion loss of 10.5 dB (including 10 dB pad and 0.5dB cable) was Entered as an offset in the power meter to allow for direct reading of power.

**IEEE 802.11an HT20 Mode / UNII Band 1 (Two TX)**

Channel	Channel Frequency (MHz)	Power (dBm)		Power Total		Power Limit		Pass / Fail
		Chain 1	Chain 2	(dBm)	(W)	(dBm)	(W)	
Low	5180	16.68	17.11	19.91	0.0979	24	0.25	PASS
Middle	5220	16.79	16.90	19.85	0.0966	24	0.25	PASS
High	5240	17.08	17.10	20.10	0.1023	24	0.25	PASS

**Remark:**

1. At final test to get the worst-case emission at 13 Mbps.
2. The cable assembly insertion loss of 10.5 dB (including 10 dB pad and 0.5 dB cable) was Entered as an offset in the power meter to allow for direct reading of power.
3. Array gain = 0 dB for  $N_{ANT} \leq 4$ , power limit do not reduce.
4. Total peak power = Chain 1 + Chain 2.

**IEEE 802.11an HT40 Mode / UNII Band 1 (Two TX)**

Channel	Channel Frequency (MHz)	Power (dBm)		Power Total		Power Limit		Pass / Fail
		Chain 1	Chain 2	(dBm)	(W)	(dBm)	(W)	
Low	5190	12.26	12.57	15.43	0.0349	24	0.25	PASS
High	5230	16.42	16.68	19.56	0.0904	24	0.25	PASS

**Remark:**

1. At final test to get the worst-case emission at 27 Mbps.
2. The cable assembly insertion loss of 10.5 dB (including 10 dB pad and 0.5 dB cable) was Entered as an offset in the power meter to allow for direct reading of power.
3. Array gain = 0 dB for  $N_{ANT} \leq 4$ , power limit do not reduce.
4. Total peak power = Chain 1 + Chain 2.

**IEEE 802.11a Mode / UNII Band 2A**

Channel	Channel Frequency (MHz)	Power		Power Limit		Pass / Fail
		(dBm)	(W)	(dBm)	(W)	
Low	5260	17.47	0.0559	24	0.25	PASS
Middle	5280	17.23	0.0529	24	0.25	PASS
High	5320	17.49	0.0561	24	0.25	PASS

**Remark:**

1. At final test to get the worst-case emission at 6 Mbps.
2. The cable assembly insertion loss of 10.5 dB (including 10 dB pad and 0.5 dB cable) was Entered as an offset in the power meter to allow for direct reading of power.

**IEEE 802.11an HT20 Mode / UNII Band 2A (Two TX)**

Channel	Channel Frequency (MHz)	Power (dBm)		Power Total		Power Limit		Pass / Fail
		Chain 1	Chain 2	(dBm)	(W)	(dBm)	(W)	
Low	5260	16.56	16.95	19.77	0.0948	24	0.25	PASS
Middle	5280	16.88	17.20	20.05	0.1012	24	0.25	PASS
High	5320	16.35	16.84	19.61	0.0914	24	0.25	PASS

**Remark:**

1. At final test to get the worst-case emission at 13 Mbps.
2. The cable assembly insertion loss of 10.5 dB (including 10 dB pad and 0.5 dB cable) was Entered as an offset in the power meter to allow for direct reading of power.
3. Array gain = 0 dB for  $N_{ANT} \leq 4$ , power limit do not reduce.
4. Total peak power = Chain 1 + Chain 2.

**IEEE 802.11an HT40 Mode / UNII Band 2A (Two TX)**

Channel	Channel Frequency (MHz)	Power (dBm)		Power Total		Power Limit		Pass / Fail
		Chain 1	Chain 2	(dBm)	(W)	(dBm)	(W)	
Low	5270	16.41	16.62	19.52	0.0895	24	0.25	PASS
High	5310	12.68	12.96	15.83	0.0383	24	0.25	PASS

**Remark:**

1. At final test to get the worst-case emission at 27Mbps.
2. The cable assembly insertion loss of 10.5 dB (including 10 dB pad and 0.5 dB cable) was Entered as an offset in the power meter to allow for direct reading of power.
3. Array gain = 0 dB for  $N_{ANT} \leq 4$ , power limit do not reduce.
4. Total peak power = Chain 1 + Chain 2.

**IEEE 802.11a Mode / UNII Band 2C**

Channel	Channel Frequency (MHz)	Power		Power Limit		Pass / Fail
		(dBm)	(W)	(dBm)	(W)	
Low	5500	17.12	0.0515	24	0.25	PASS
Middle	5580	17.34	0.0542	24	0.25	PASS
High	5700	14.40	0.0276	24	0.25	PASS

**Remark:**

1. At final test to get the worst-case emission at 6 Mbps.
2. The cable assembly insertion loss of 10.5 dB (including 10 dB pad and 0.5dB cable) was Entered as an offset in the power meter to allow for direct reading of power.

**IEEE 802.11an HT20 Mode / UNII Band 2C (Two TX)**

Channel	Channel Frequency (MHz)	Power (dBm)		Power Total		Power Limit		Pass / Fail
		Chain 1	Chain 2	(dBm)	(W)	(dBm)	(W)	
Low	5500	15.27	15.90	18.60	0.0724	24	0.25	PASS
Middle	5580	16.94	16.66	19.81	0.0957	24	0.25	PASS
High	5700	14.21	14.24	17.24	0.0530	24	0.25	PASS

**Remark:**

1. At final test to get the worst-case emission at 13 Mbps.
2. The cable assembly insertion loss of 10.5 dB (including 10 dB pad and 0.5dB cable) was Entered as an offset in the power meter to allow for direct reading of power.
3. Array gain = 0 dB for  $N_{ANT} \leq 4$ , power limit do not reduce.
4. Total peak power = Chain 1 + Chain 2.

**IEEE 802.11an HT40 Mode / UNII Band 2C (Two TX)**

Channel	Channel Frequency (MHz)	Power (dBm)		Power Total		Power Limit		Pass / Fail
		Chain 1	Chain 2	(dBm)	(W)	(dBm)	(W)	
Low	5510	10.94	11.16	14.06	0.0255	24	0.25	PASS
Middle	5550	16.52	16.83	19.69	0.0931	24	0.25	PASS
High	5670	15.63	15.78	18.72	0.0745	24	0.25	PASS

**Remark:**

1. At final test to get the worst-case emission at 27 Mbps.
2. The cable assembly insertion loss of 10.5 dB (including 10 dB pad and 0.5 dB cable) was Entered as an offset in the power meter to allow for direct reading of power.
3. Array gain = 0 dB for  $N_{ANT} \leq 4$ , power limit do not reduce.
4. Total peak power = Chain 1 + Chain 2.

**IEEE 802.11a Mode / UNII Band 3**

Channel	Channel Frequency (MHz)	Power		Power Limit		Pass / Fail
		(dBm)	(W)	(dBm)	(W)	
Low	5745	12.74	0.0188	30	1	PASS
Middle	5785	17.66	0.0583	30	1	PASS
High	5825	15.66	0.0368	30	1	PASS

**Remark:**

1. At final test to get the worst-case emission at 6 Mbps.
2. The cable assembly insertion loss of 10.5 dB (including 10 dB pad and 0.5 dB cable) was Entered as an offset in the power meter to allow for direct reading of power.

**IEEE 802.11an HT20 Mode / UNII Band 3 (Two TX)**

Channel	Channel Frequency (MHz)	Power (dBm)		Power Total		Power Limit		Pass / Fail
		Chain 1	Chain 2	(dBm)	(W)	(dBm)	(W)	
Low	5745	10.91	10.83	13.88	0.0244	30	1	PASS
Middle	5785	17.54	17.73	20.65	0.1161	30	1	PASS
High	5825	13.78	13.84	16.82	0.0481	30	1	PASS

**Remark:**

1. At final test to get the worst-case emission at 13 Mbps.
2. The cable assembly insertion loss of 10.5 dB (including 10 dB pad and 0.5 dB cable) was Entered as an offset in the power meter to allow for direct reading of power.
3. Array gain = 0 dB for  $N_{ANT} \leq 4$ , power limit do not reduce.
4. Total peak power = Chain 1 + Chain 2.

**IEEE 802.11an HT40 Mode / UNII Band 3 (Two TX)**

Channel	Channel Frequency (MHz)	Power (dBm)		Power Total		Power Limit		Pass / Fail
		Chain 1	Chain 2	(dBm)	(W)	(dBm)	(W)	
Low	5755	9.91	9.76	12.85	0.0193	30	1	PASS
High	5795	15.18	15.27	18.24	0.0667	30	1	PASS

**Remark:**

1. At final test to get the worst-case emission at 27 Mbps.
2. The cable assembly insertion loss of 10.5 dB (including 10 dB pad and 0.5dB cable) was Entered as an offset in the power meter to allow for direct reading of power.
3. Array gain = 0 dB for  $N_{ANT} \leq 4$ , power limit do not reduce.
4. Total peak power = Chain 1 + Chain 2.

## 7.3 PEAK POWER SPECTRAL DENSITY

### LIMITS

#### § 15.407 (a)

##### (1) For the band 5.15-5.25 GHz

(I) For an outdoor access point operating in the band 5.15-5.25 GHz, the maximum conducted output power over the frequency band of operation shall not exceed 1 W provided the maximum antenna gain does not exceed 6 dBi. In addition, the maximum power spectral density shall not exceed 17 dBm in any 1 megahertz band. If transmitting antennas of directional gain greater than 6 dBi are used, both the maximum conducted output power and the maximum power spectral density shall be reduced by the amount in dB that the directional gain of the antenna exceeds 6dBi. The maximum e.i.r.p. at any elevation angle above 30 degrees as measured from the horizon must not exceed 125 mW (21 dBm).

(II) For an indoor access point operating in the band 5.15-5.25 GHz, the maximum conducted output power over the frequency band of operation shall not exceed 1 W provided the maximum antenna gain does not exceed 6 dBi. In addition, the maximum power spectral density shall not exceed 17 dBm in any 1 megahertz band. If transmitting antennas of directional gain greater than 6 dBi are used, both the maximum conducted output power and the maximum power spectral density shall be reduced by the amount in dB that the directional gain of the antenna exceeds 6dBi.

(IV) For mobile and portable client devices in the 5.15-5.25 GHz band, the maximum conducted output power over the frequency band of operation shall not exceed 250 mW provided the maximum antenna gain does not exceed 6 dBi. In addition, the maximum power spectral density shall not exceed 11 dBm in any 1 megahertz band. If transmitting antennas of directional gain greater than 6 dBi are used, both the maximum conducted output power and the maximum power spectral density shall be reduced by the amount in dB that the directional gain of the antenna exceeds 6dBi.



- (2) For the 5.25-5.35 GHz and 5.47-5.725 GHz bands, the maximum conducted output power over the frequency bands of operation shall not exceed the lesser of 250 mW or 11 dBm 10 log B, where B is the 26 dB emission bandwidth in megahertz. In addition, the maximum power spectral density shall not exceed 11 dBm in any 1 megahertz band. If transmitting antennas of directional gain greater than 6 dBi are used, both the maximum conducted output power and the maximum power spectral density shall be reduced by the amount in dB that the directional gain of the antenna exceeds 6 dBi.
- (3) For the band 5.725-5.85 GHz, the maximum conducted output power over the frequency band of operation shall not exceed 1 W. In addition, the maximum power spectral density shall not exceed 30 dBm in any 500-kHz band. If transmitting antennas of directional gain greater than 6 dBi are used, both the maximum conducted output power and the maximum power spectral density shall be reduced by the amount in dB that the directional gain of the antenna exceeds 6 dBi. However, fixed point-to-point U-NII devices operating in this band may employ transmitting antennas with directional gain greater than 6 dBi without any corresponding reduction in transmitter conducted power. Fixed, point-to-point operations exclude the use of point-to-multipoint systems, omnidirectional applications, and multiple collocated transmitters transmitting the same information. The operator of the U-NII device, or if the equipment is professionally installed, the installer, is responsible for ensuring that systems employing high gain directional antennas are used exclusively for fixed, point-to-point operations.

**TEST EQUIPMENT**

Name of Equipment	Manufacturer	Model	Serial Number	Calibration Due
EXA Signal Analyzer	Agilent	N9010A	MY52220817	03/19/2016

*Remark: Each piece of equipment is scheduled for calibration once a year.*

**TEST SETUP**



**TEST PROCEDURE**

1. Place the EUT on the table and set it in transmitting mode.  
Remove the antenna from the EUT and then connect a low loss RF cable from the antenna port to the spectrum analyzer.
2. Set the spectrum analyzer as RBW = 1MHz, VBW = 3MHz, Span = Sweep= AUTO
3. Record the max. reading.
4. Repeat the above procedure until the measurements for all frequencies are completed.

**TEST RESULTS**

**IEEE 802.11a Mode**

U-NII	Channel	Channel Frequency (MHz)	PPSD (dBm)	Minimum Limit (dBm/MHz)	Pass / Fail
Band 1	Low	5180	5.470	11	PASS
	Middle	5200	5.542	11	PASS
	High	5240	5.787	11	PASS

**Remark:**

1. At final test to get the worst-case emission at 6Mbps.
2. The cable assembly insertion loss of 10.5 dB (including 10 dB pad and 0.5 dB cable) was Entered as an offset in the spectrum analyzer to allow for direct reading of power.

**IEEE 802.11an HT20 Mode (Two TX)**

U-NII	Channel	Channel Frequency (MHz)	PPSD (dBm)		PSD Total (dBm)	Minimum Limit (dBm/MHz)	Pass / Fail
			Chain 1	Chain 2			
Band 1	Low	5180	5.31	5.30	8.31	11.00	PASS
	Middle	5200	5.06	5.22	8.15	11.00	PASS
	High	5240	5.23	5.47	8.36	11.00	PASS

**Remark:**

1. At final test to get the worst-case emission at 13Mbps.
2. The cable assembly insertion loss of 10.5 dB (including 10 dB pad and 0.5 dB cable) was Entered as an offset in the spectrum analyzer to allow for direct reading of power.
3. The maximum antenna gain is -1.99dBi which is more than 6dBi, the limit should be 11dBm.
4. Total power spectral density = Chain 1 + Chain 2.

**IEEE 802.11n HT40 Mode (Two TX)**

U-NII	Channel	Channel Frequency (MHz)	PPSD (dBm)		PSD Total (dBm)	Minimum Limit (dBm/MHz)	Pass / Fail
			Chain 1	Chain 2			
Band 1	Low	5190	-2.06	-1.90	1.03	11.00	PASS
	High	5230	3.22	2.38	5.83	11.00	PASS

**Remark:**

1. At final test to get the worst-case emission at 27Mbps.
2. The cable assembly insertion loss of 10.5 dB (including 10 dB pad and 0.5 dB cable) was Entered as an offset in the spectrum analyzer to allow for direct reading of power.
3. The maximum antenna gain is -1.99dBi which is more than 6dBi, the limit should be 11dBm.
4. Total power spectral density = Chain 1 + Chain 2.

**IEEE 802.11a Mode**

U-NII	Channel	Channel Frequency (MHz)	PPSD (dBm)	Minimum Limit (dBm/MHz)	Pass / Fail
Band 2A	Low	5260	5.629	11	PASS
	Middle	5300	5.601	11	PASS
	High	5320	5.911	11	PASS

**Remark:**

1. At final test to get the worst-case emission at 6Mbps.
2. The cable assembly insertion loss of 10.5 dB (including 10 dB pad and 0.5 dB cable) was Entered as an offset in the spectrum analyzer to allow for direct reading of power.

**IEEE 802.11an HT20 Mode (Two TX)**

U-NII	Channel	Channel Frequency (MHz)	PPSD (dBm)		PSD Total (dBm)	Minimum Limit (dBm/MHz)	Pass / Fail
			Chain 1	Chain 2			
Band 2A	Low	5260	5.28	5.21	8.25	11.00	PASS
	Middle	5300	5.44	5.49	8.48	11.00	PASS
	High	5320	4.98	5.13	8.07	11.00	PASS

**Remark:**

1. At final test to get the worst-case emission at 13Mbps.
2. The cable assembly insertion loss of 10.5 dB (including 10 dB pad and 0.5 dB cable) was Entered as an offset in the spectrum analyzer to allow for direct reading of power.
3. The maximum antenna gain is -1.99dBi which is more than 6dBi, the limit should be 11dBm.
4. Total power spectral density = Chain 1 + Chain 2.

**IEEE 802.11n HT40 Mode (Two TX)**

U-NII	Channel	Channel Frequency (MHz)	PPSD (dBm)		PSD Total (dBm)	Minimum Limit (dBm/MHz)	Pass / Fail
			Chain 1	Chain 2			
Band 2A	Low	5270	2.22	2.27	5.25	11.00	PASS
	High	5310	-1.15	-1.32	1.78	11.00	PASS

**Remark:**

1. At final test to get the worst-case emission at 27Mbps.
2. The cable assembly insertion loss of 10.5 dB (including 10 dB pad and 0.5 dB cable) was Entered as an offset in the spectrum analyzer to allow for direct reading of power.
3. The maximum antenna gain is -1.99dBi which is more than 6dBi, the limit should be 11dBm.
4. Total power spectral density = Chain 1 + Chain 2.

**IEEE 802.11a Mode**

U-NII	Channel	Channel Frequency (MHz)	PPSD (dBm)	Minimum Limit (dBm/MHz)	Pass / Fail
Band 2C	Low	5500	5.026	11	PASS
	Middle	5580	5.413	11	PASS
	High	5700	2.872	11	PASS

**Remark:**

1. At final test to get the worst-case emission at 6Mbps.
2. The cable assembly insertion loss of 10.5 dB (including 10 dB pad and 0.5 dB cable) was Entered as an offset in the spectrum analyzer to allow for direct reading of power.

**IEEE 802.11an HT20 Mode (Two TX)**

U-NII	Channel	Channel Frequency (MHz)	PPSD (dBm)		PSD Total (dBm)	Minimum Limit (dBm/MHz)	Pass / Fail
			Chain 1	Chain 2			
Band 2C	Low	5500	3.50	3.98	6.75	11.00	PASS
	Middle	5580	4.72	4.85	7.80	11.00	PASS
	High	5700	1.83	1.78	4.81	11.00	PASS

**Remark:**

1. At final test to get the worst-case emission at 13Mbps.
2. The cable assembly insertion loss of 10.5 dB (including 10 dB pad and 0.5 dB cable) was Entered as an offset in the spectrum analyzer to allow for direct reading of power.
3. The maximum antenna gain is -1.99dBi which is more than 6dBi, the limit should be 11dBm.
4. Total power spectral density = Chain 1 + Chain 2.

**IEEE 802.11n HT40 Mode (Two TX)**

U-NII	Channel	Channel Frequency (MHz)	PPSD (dBm)		PSD Total (dBm)	Minimum Limit (dBm/MHz)	Pass / Fail
			Chain 1	Chain 2			
Band 2C	Low	5510	-3.44	-3.12	-0.26	11.00	PASS
	Middle	5550	2.35	2.43	5.40	11.00	PASS
	High	5670	1.28	1.05	4.18	11.00	PASS

**Remark:**

1. At final test to get the worst-case emission at 27Mbps.
2. The cable assembly insertion loss of 10.5 dB (including 10 dB pad and 0.5 dB cable) was Entered as an offset in the spectrum analyzer to allow for direct reading of power.
3. The maximum antenna gain is -1.99dBi which is more than 6dBi, the limit should be 11dBm.
4. Total power spectral density = Chain 1 + Chain 2.

**IEEE 802.11a Mode**

U-NII	Channel	Channel Frequency (MHz)	PPSD (dBm)	Minimum Limit (dBm/MHz)	Pass / Fail
Band 3	Low	5745	-1.757	30	PASS
	Middle	5785	2.760	30	PASS
	High	5825	1.059	30	PASS

**Remark:**

1. At final test to get the worst-case emission at 6Mbps.
2. The cable assembly insertion loss of 10.5 dB (including 10 dB pad and 0.5 dB cable) was Entered as an offset in the spectrum analyzer to allow for direct reading of power.

**IEEE 802.11an HT20 Mode (Two TX)**

U-NII	Channel	Channel Frequency (MHz)	PPSD (dBm)		PSD Total (dBm)	Minimum Limit (dBm/500kHz)	Pass / Fail
			Chain 1	Chain 2			
Band 3	Low	5745	-4.05	-4.55	-1.29	30.00	PASS
	Middle	5785	2.29	2.58	5.45	30.00	PASS
	High	5825	-0.92	-1.08	2.01	30.00	PASS

**Remark:**

1. At final test to get the worst-case emission at 13Mbps.
2. The cable assembly insertion loss of 10.5 dB (including 10 dB pad and 0.5 dB cable) was Entered as an offset in the spectrum analyzer to allow for direct reading of power.
3. The maximum antenna gain is -1.99dBi which is more than 6dBi, the limit should be 30dBm.
4. Total power spectral density = Chain 1 + Chain 2.

**IEEE 802.11an HT40 Mode (Two TX)**

U-NII	Channel	Channel Frequency (MHz)	PPSD (dBm)		PSD Total (dBm)	Minimum Limit (dBm/500kHz)	Pass / Fail
			Chain 1	Chain 2			
Band 3	Low	5755	-7.13	-7.55	-4.32	30.00	PASS
	High	5795	-2.13	-1.31	1.31	30.00	PASS

**Remark:**

1. At final test to get the worst-case emission at 27Mbps.
2. The cable assembly insertion loss of 10.5 dB (including 10 dB pad and 0.5 dB cable) was Entered as an offset in the spectrum analyzer to allow for direct reading of power.
3. The maximum antenna gain is -1.99dBi which is more than 6dBi, the limit should be 30dBm.
4. Total power spectral density = Chain 1 + Chain 2.

**POWER SPECTRAL DENSITY**

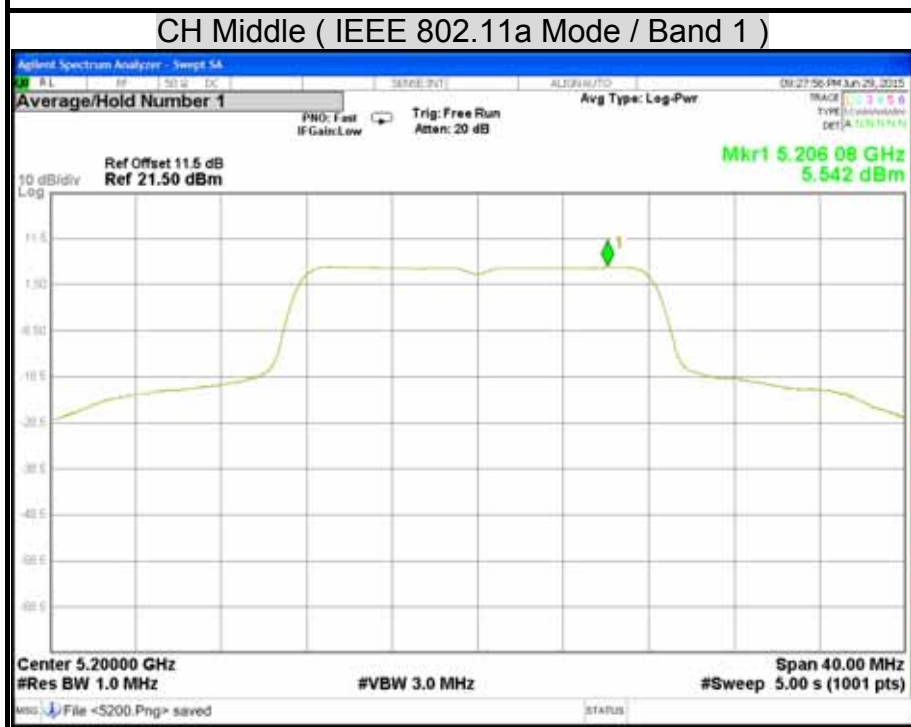
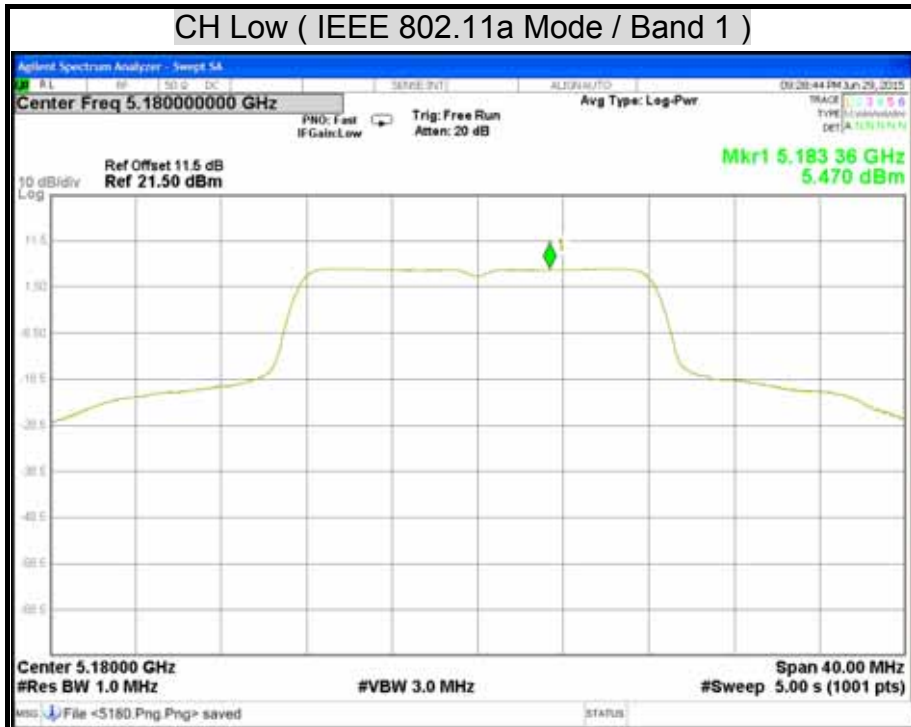



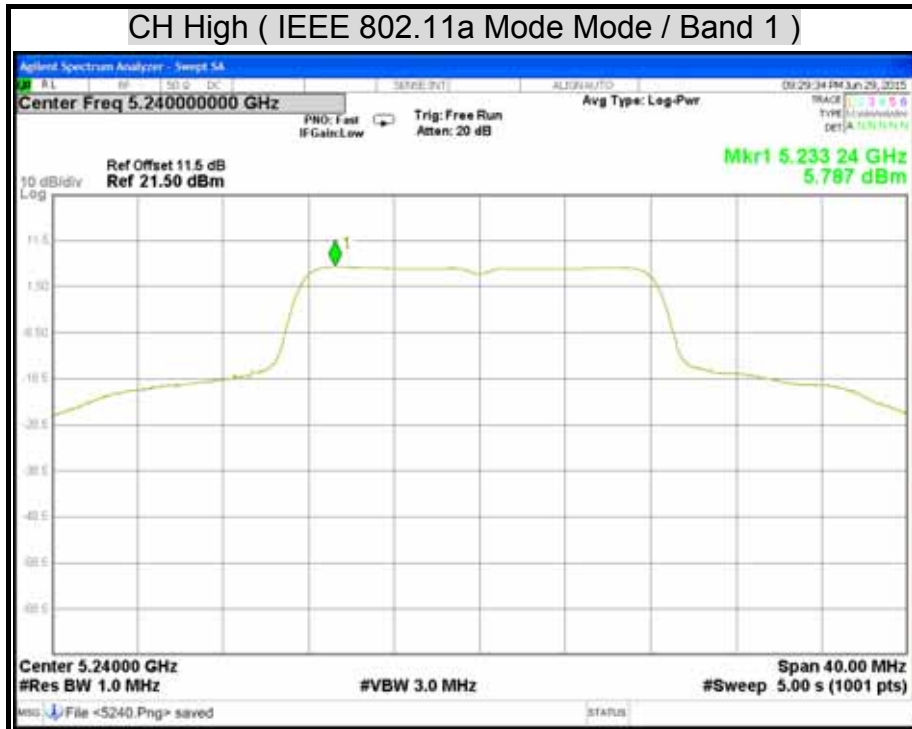

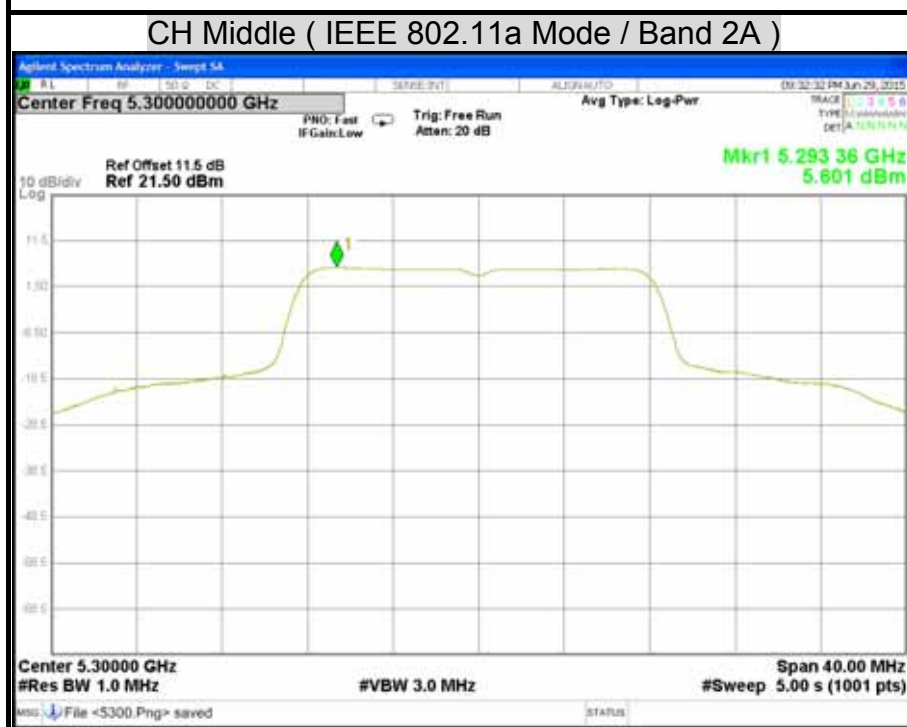
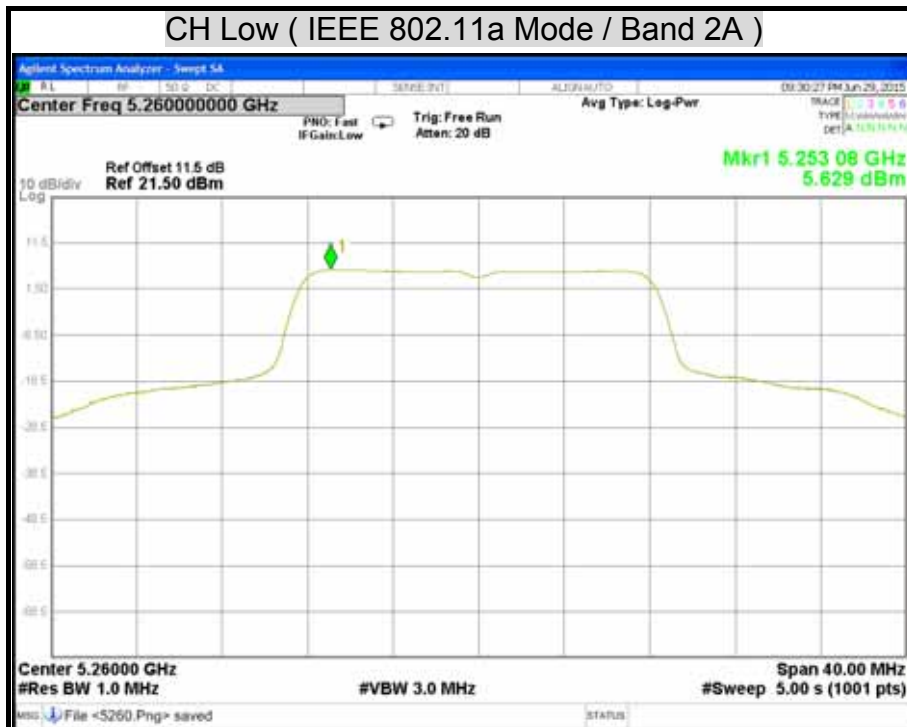

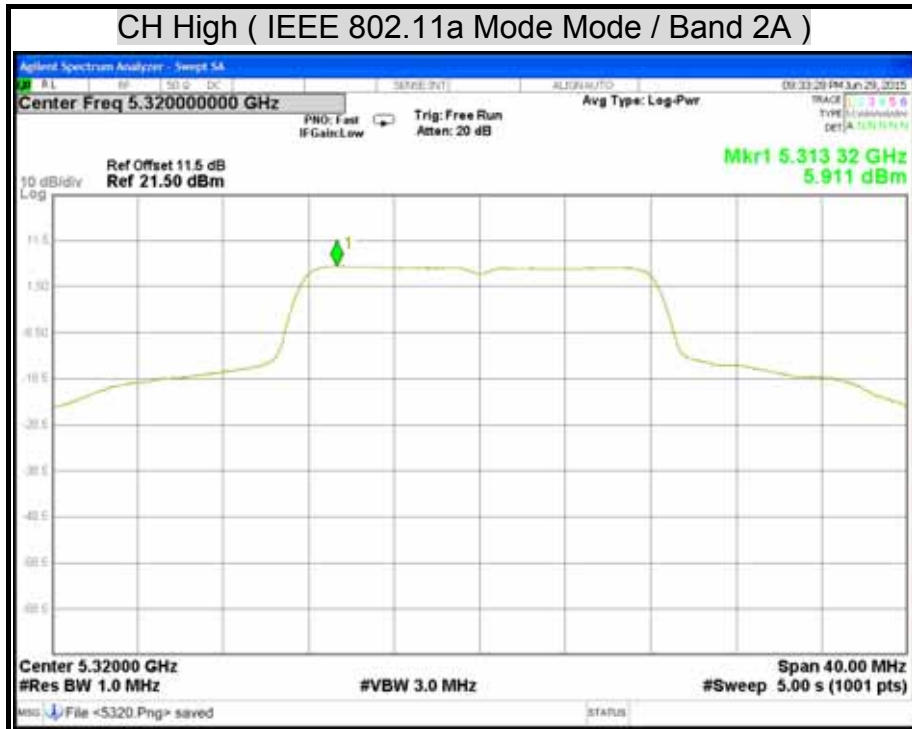

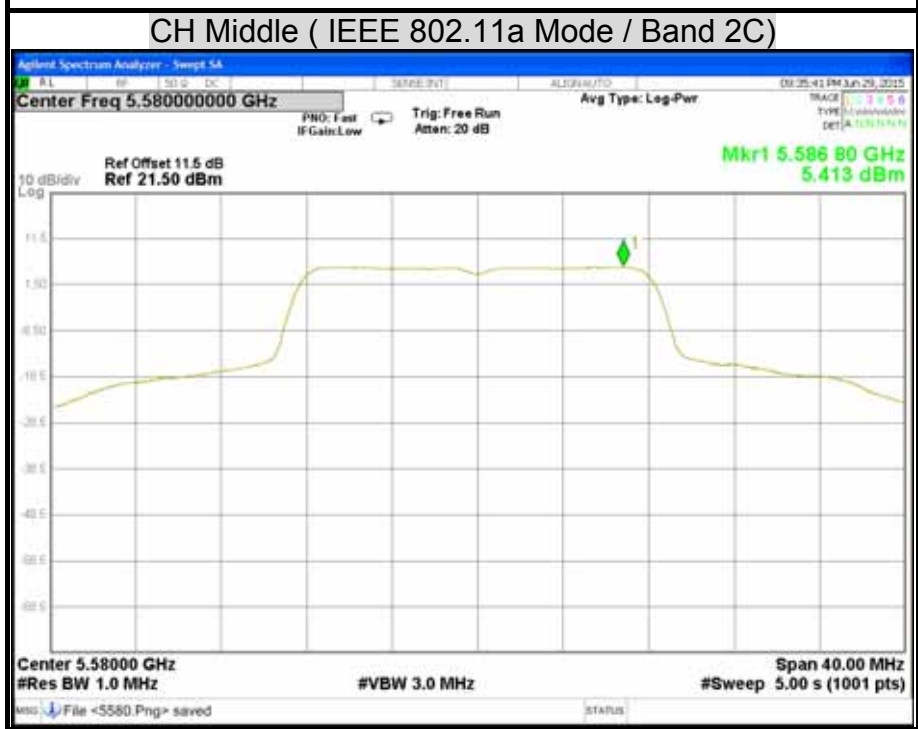
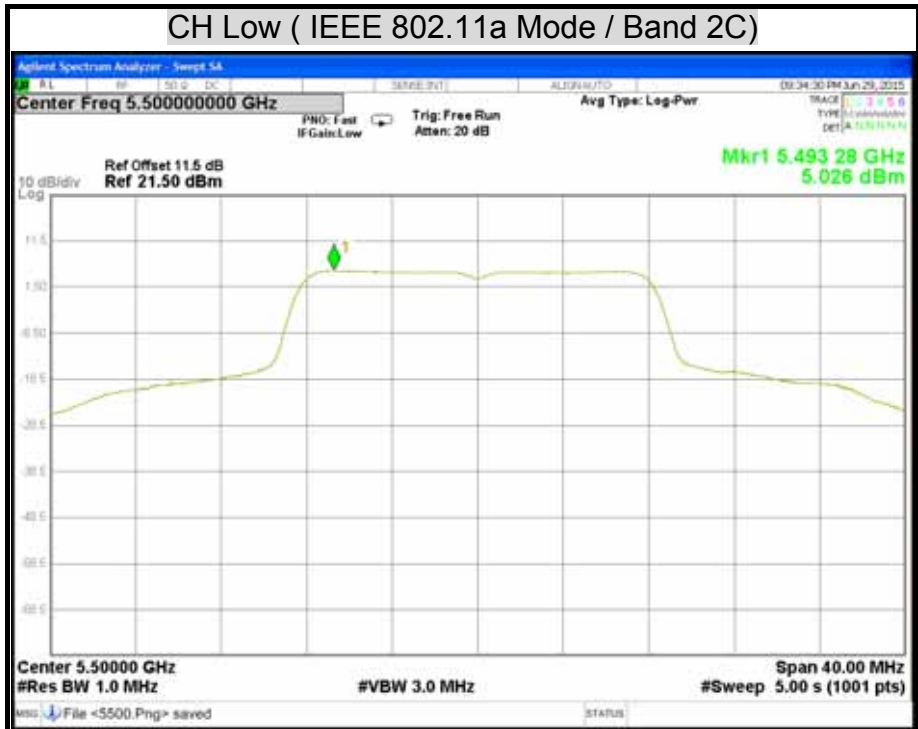



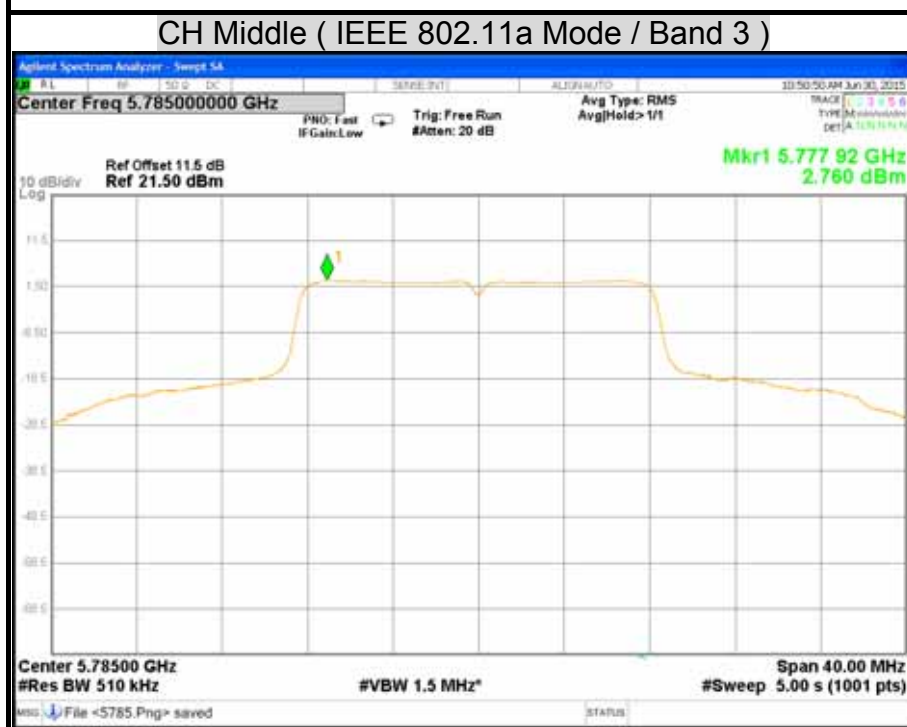
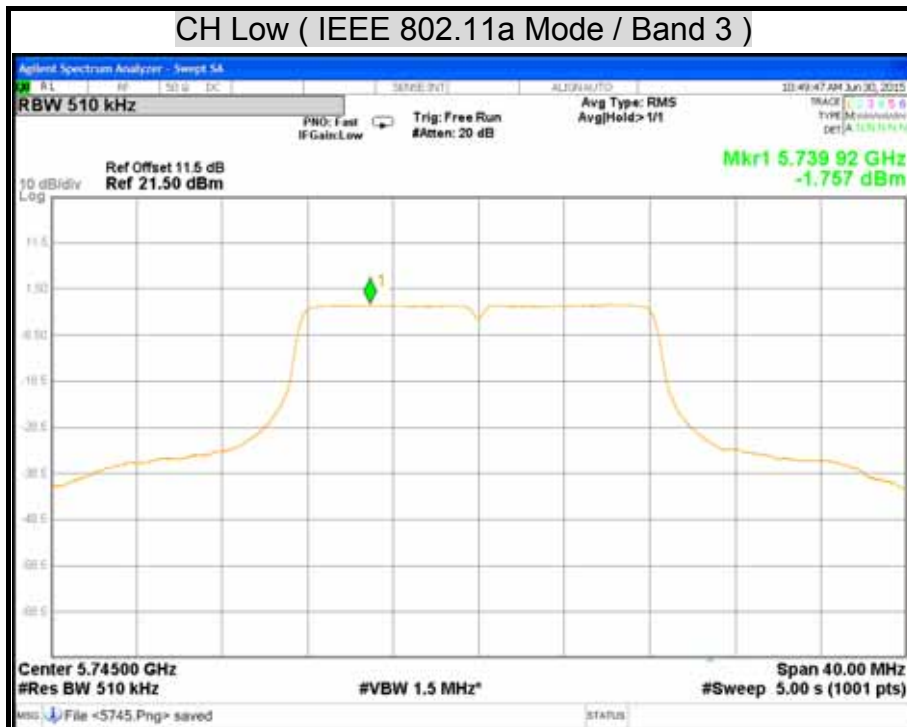

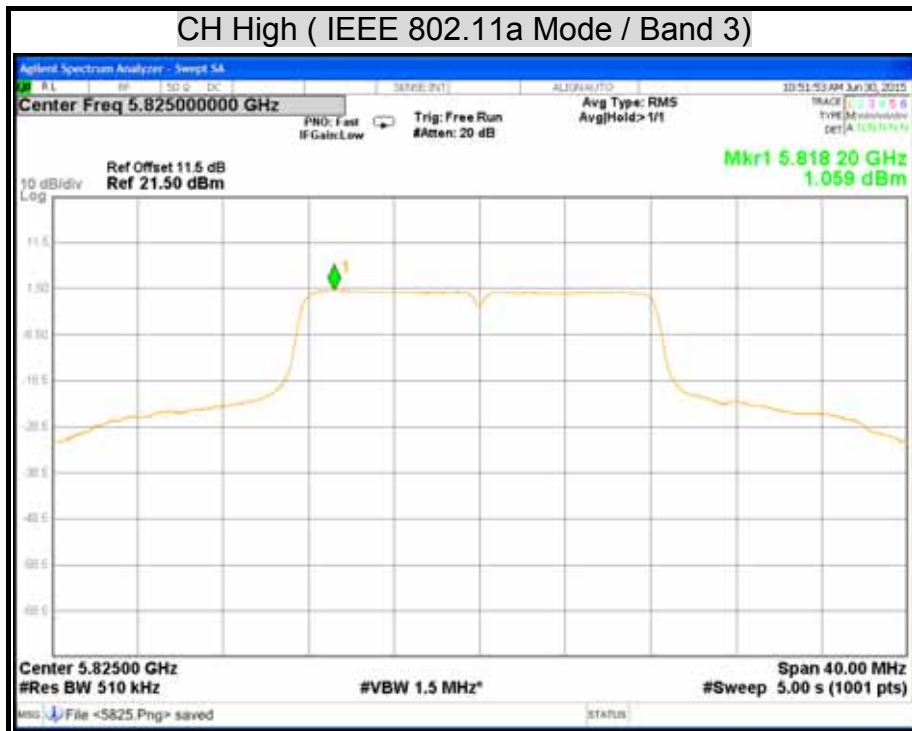

CH Low ( IEEE 802.11ac Mode VHT20 / Band 1 / Chain 1 )

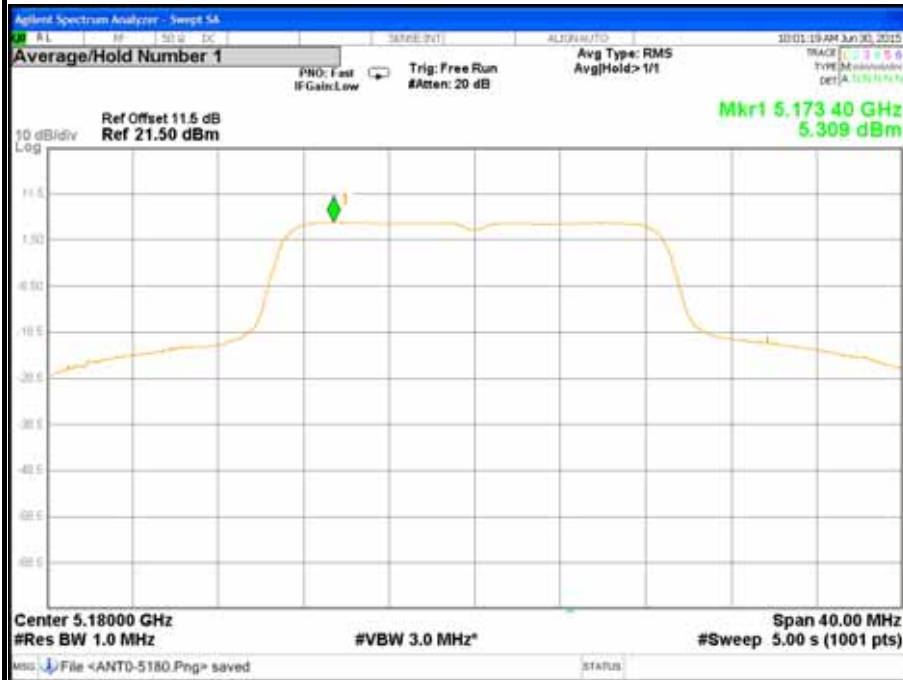

CH Middle ( IEEE 802.11ac Mode VHT20 / Band 1 / Chain 1 )







CH Low ( IEEE 802.11ac Mode VHT20 / Band 1 / Chain 2 )



CH Middle ( IEEE 802.11ac Mode VHT20 / Band 1 / Chain 2 )





CH Low ( IEEE 802.11ac Mode VHT20 / Band 2A / Chain 1 )



CH Middle ( IEEE 802.11ac Mode VHT20 / Band 2A / Chain 1 )





CH Low ( IEEE 802.11ac Mode VHT20 / Band 2A / Chain 2 )

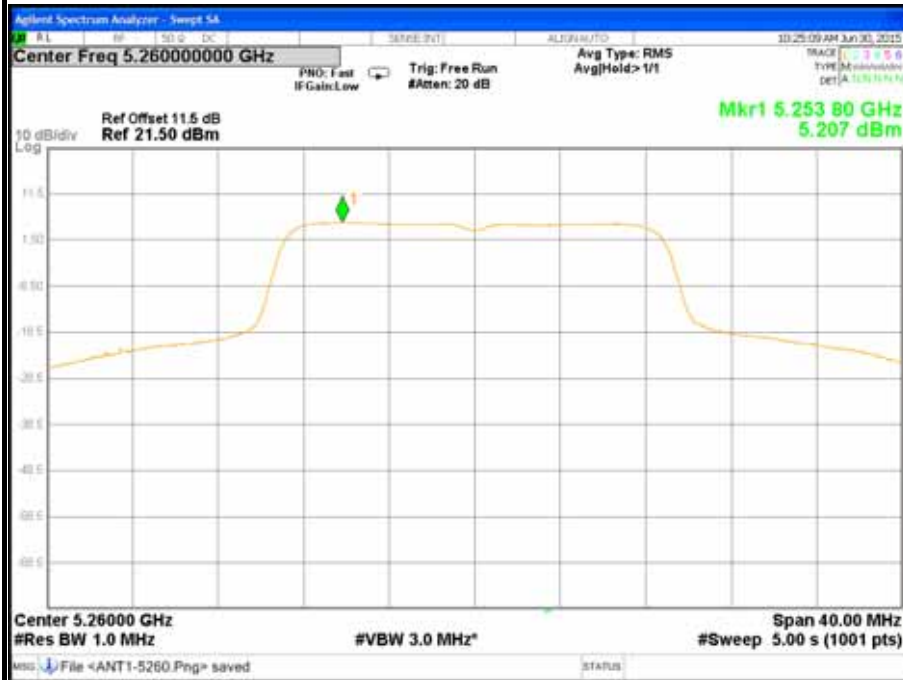

CH Middle ( IEEE 802.11ac Mode VHT20 / Band 2A / Chain 2 )



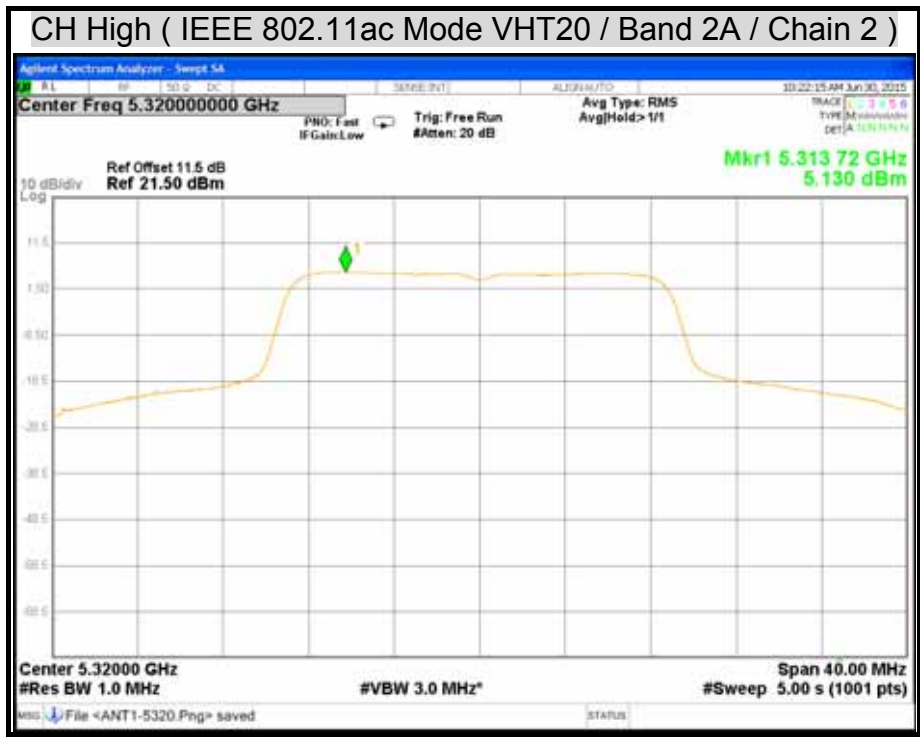

CH Low ( IEEE 802.11ac Mode VHT20 / Band 2C / Chain 1 )

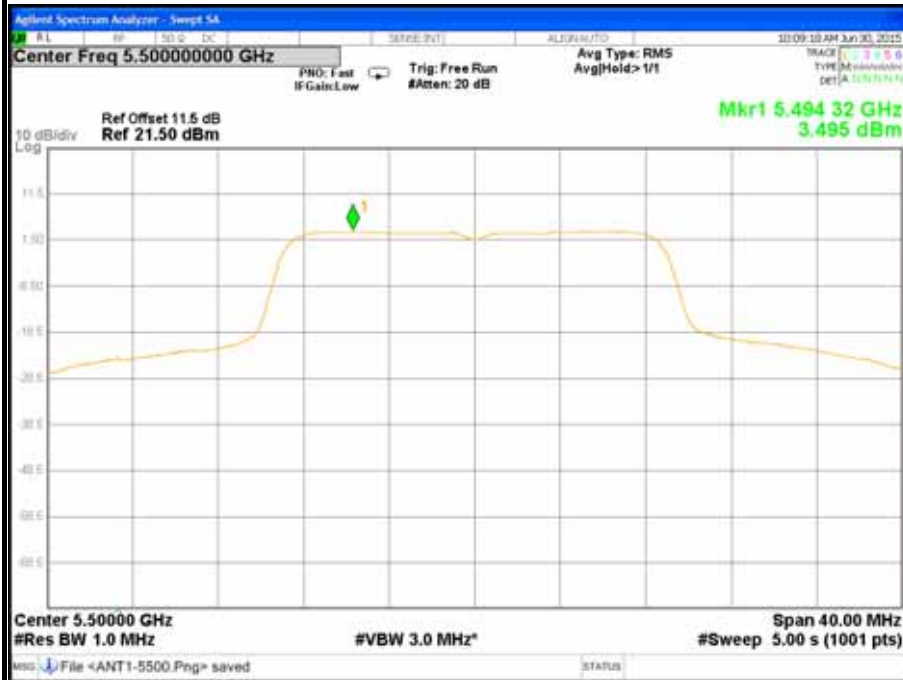

CH Middle ( IEEE 802.11ac Mode VHT20 / Band 2C / Chain 1 )

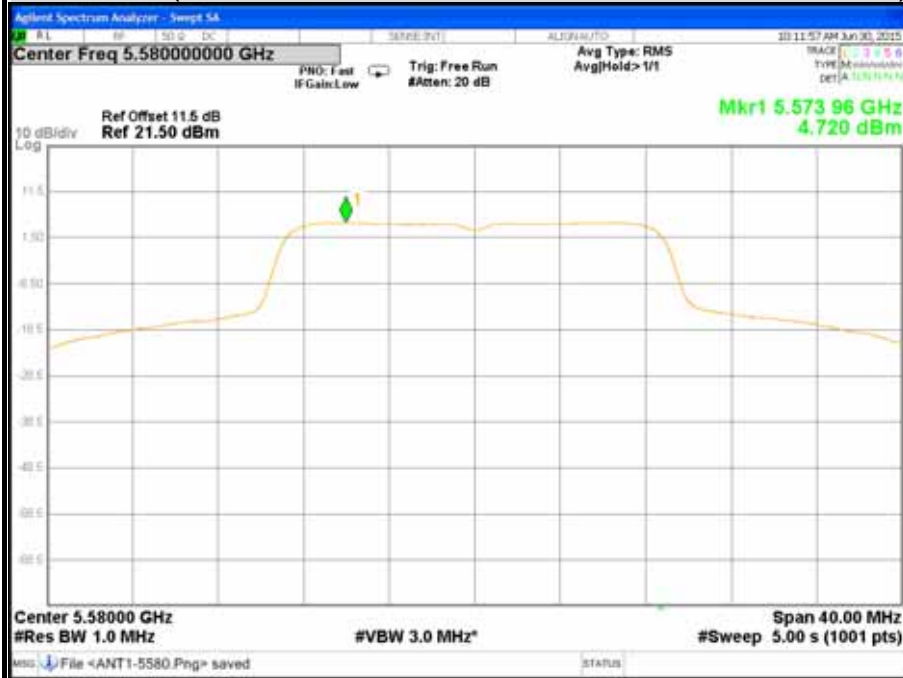





CH Low ( IEEE 802.11ac Mode VHT20 / Band 2C / Chain 2 )



CH Middle ( IEEE 802.11ac Mode VHT20 / Band 2C / Chain 2 )

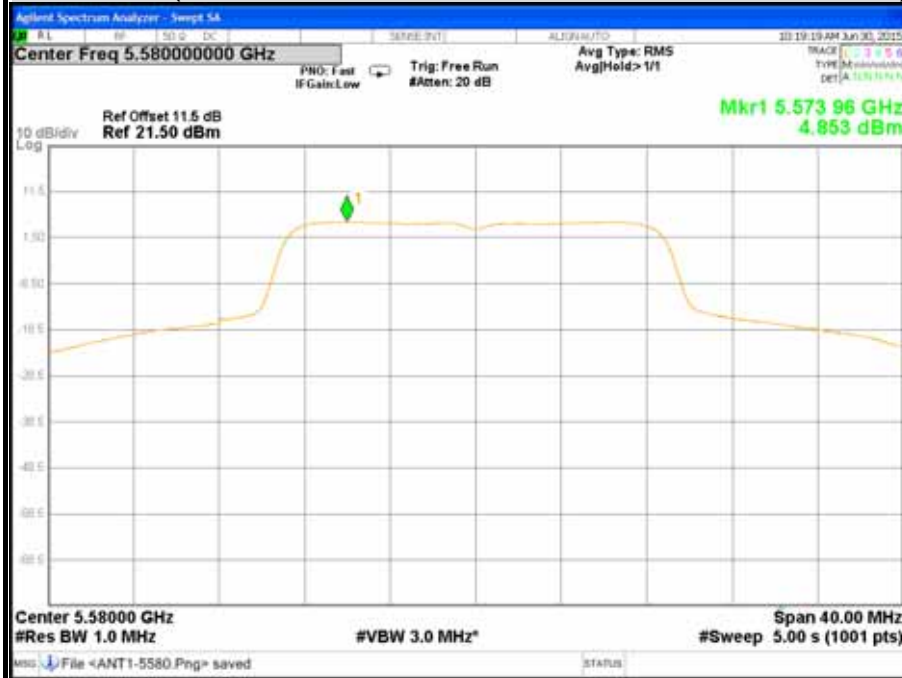

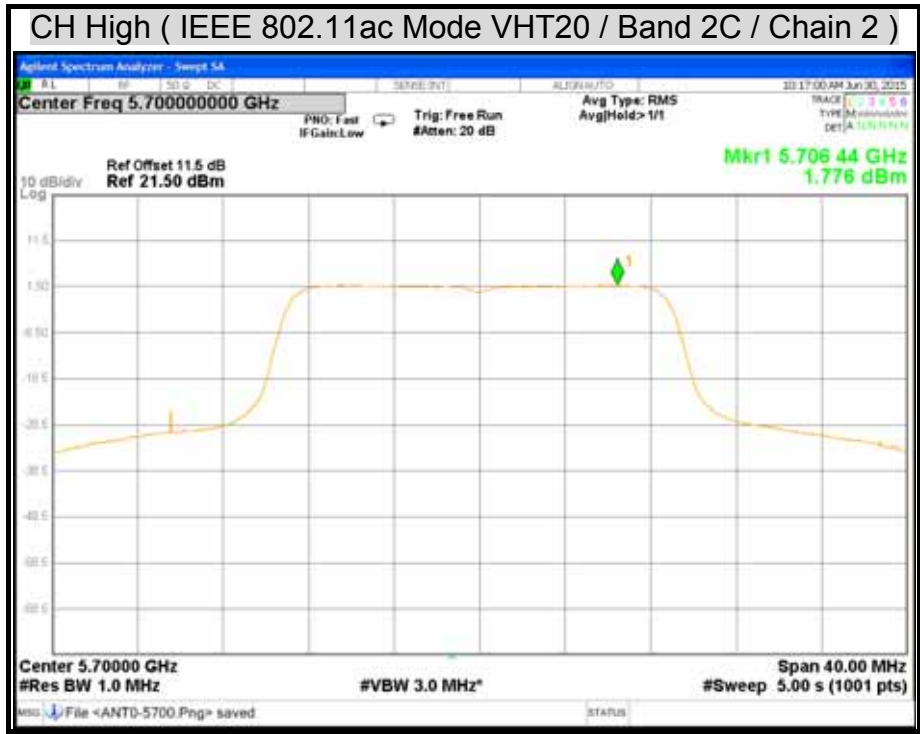

CH Low ( IEEE 802.11ac Mode VHT20 / Band 3 / Chain 1 )

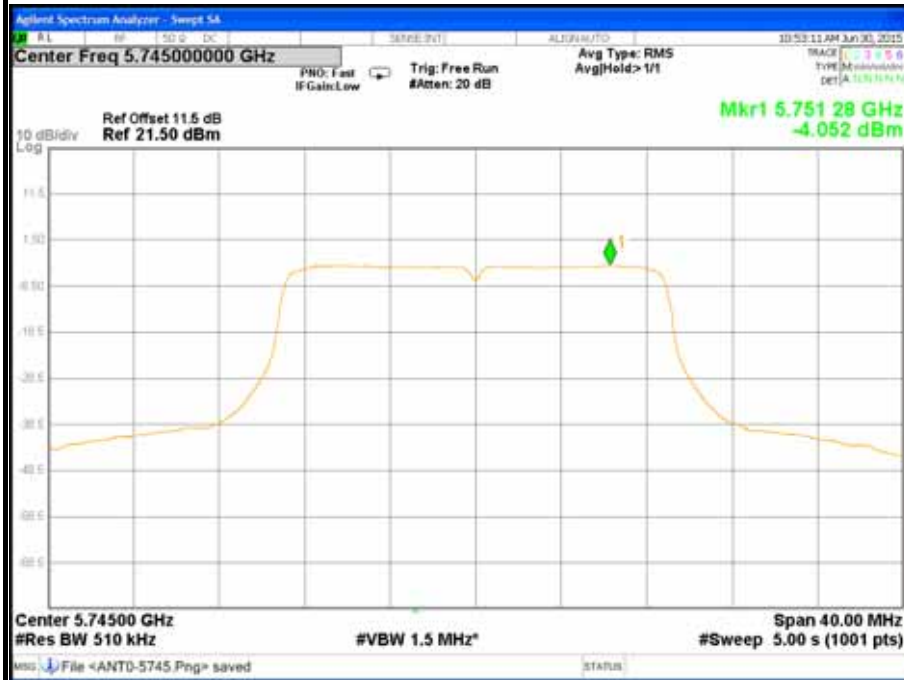

CH Middle ( IEEE 802.11ac Mode VHT20 / Band 3 / Chain 1 )





CH Low ( IEEE 802.11ac Mode VHT20 / Band 3 / Chain 2 )

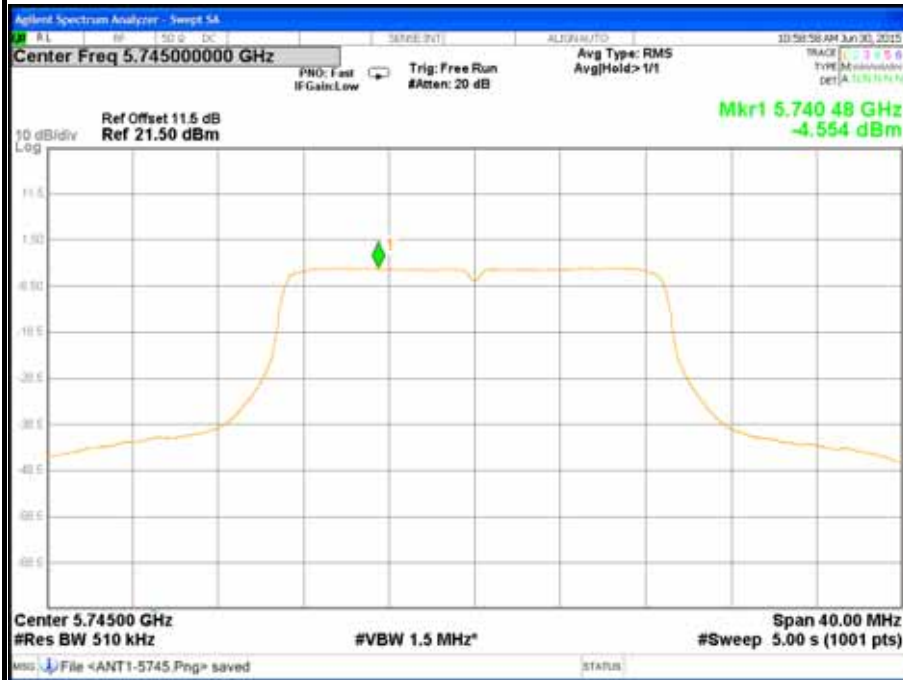

CH Middle ( IEEE 802.11ac Mode VHT20 / Band 3 / Chain 2 )





CH Low ( IEEE 802.11ac Mode VHT40 / Band 1 / Chain 1 )

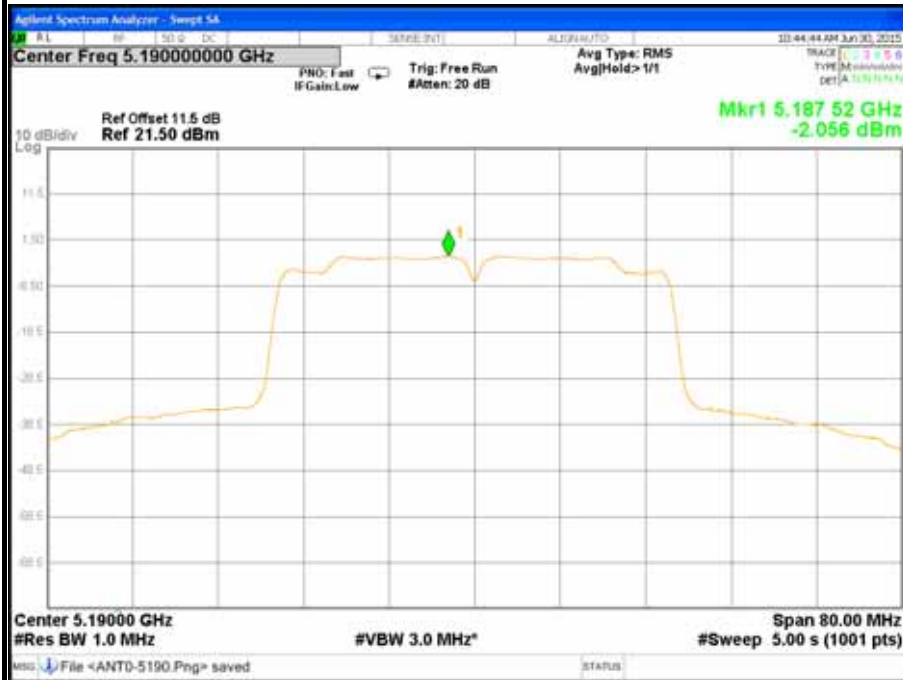

CH High ( IEEE 802.11ac Mode VHT40 / Band 1 / Chain 1 )

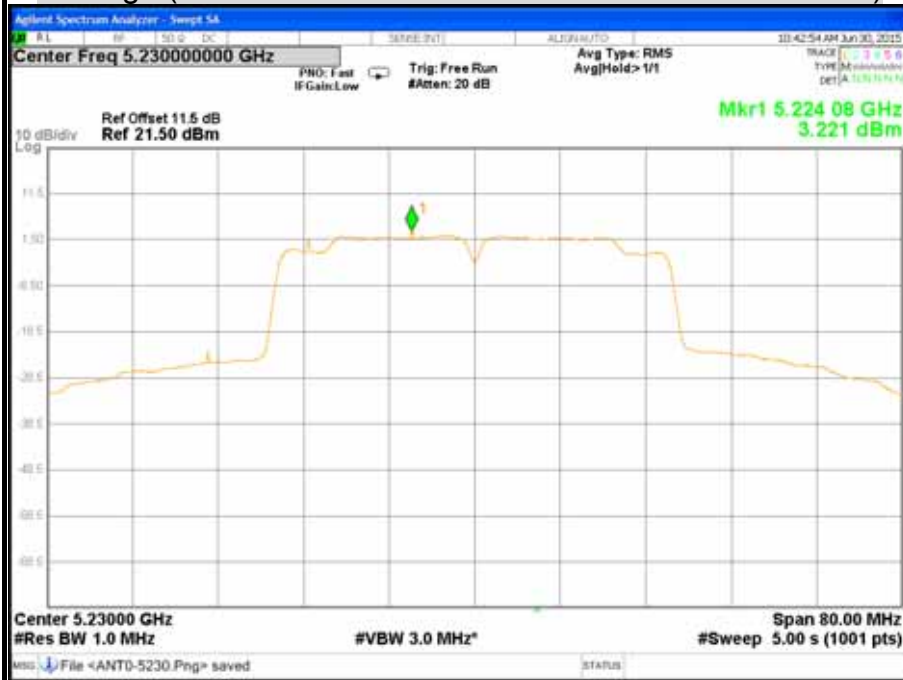



CH Low ( IEEE 802.11ac Mode VHT40 / Band 1 / Chain 2 )



CH High ( IEEE 802.11ac Mode VHT40 / Band 1 / Chain 2 )



CH Low ( IEEE 802.11ac Mode VHT40 / Band 2A / Chain 1 )



CH High ( IEEE 802.11ac Mode VHT40 / Band 2A / Chain 1 )



CH Low ( IEEE 802.11ac Mode VHT40 / Band 2A / Chain 2 )



CH High ( IEEE 802.11ac Mode VHT40 / Band 2A / Chain 2 )



CH Low ( IEEE 802.11ac Mode VHT40 / Band 2C / Chain 1 )

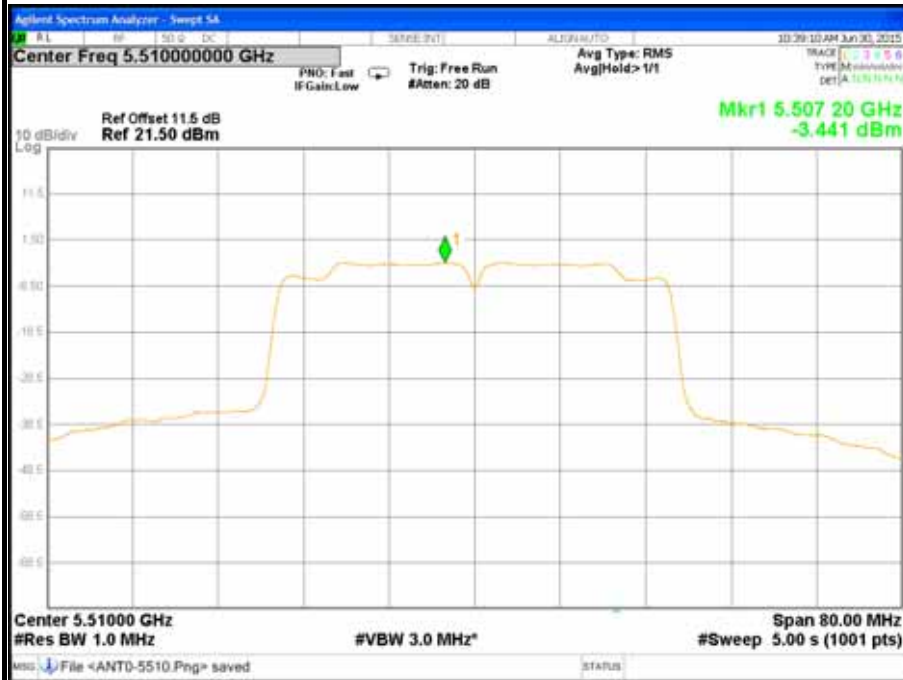

CH Middle ( IEEE 802.11ac Mode VHT40 / Band 2C / Chain 1 )





CH Low ( IEEE 802.11ac Mode VHT40 / Band 2C / Chain 2 )

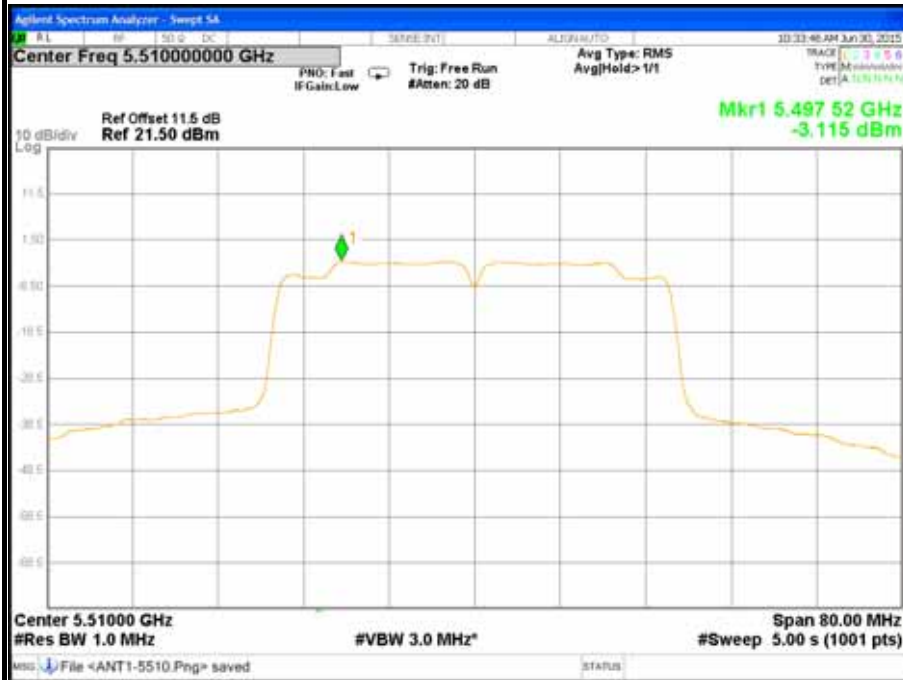

CH Middle ( IEEE 802.11ac Mode VHT40 / Band 2C / Chain 2 )





CH Low ( IEEE 802.11ac Mode VHT40 / Band 3 / Chain 1 )



CH High ( IEEE 802.11ac Mode VHT40 / Band 3 / Chain 1 )





CH Low ( IEEE 802.11ac Mode VHT40 / Band 3 / Chain 2 )

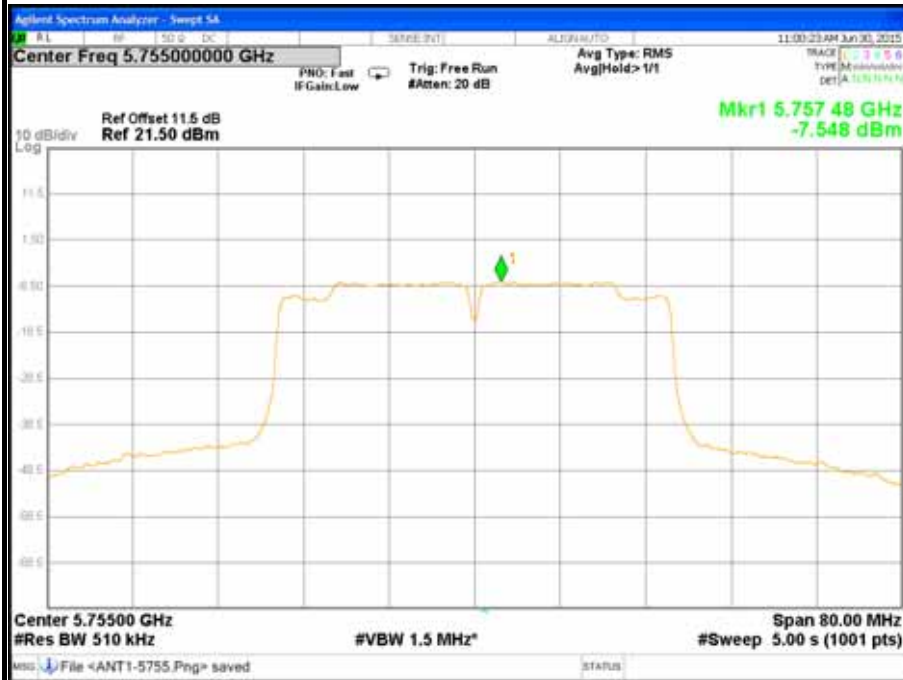

CH High ( IEEE 802.11ac Mode VHT40 / Band 3 / Chain 2 )



## 7.4 RADIATED EMISSION

### LIMITS

(1) According to § 15.205 (a) Except as shown in paragraph (d) of this section, only spurious emissions are permitted in any of the frequency bands listed below:

MHz	MHz	MHz	GHz
0.090 - 0.110	16.42 - 16.423	399.9 - 410	4.5 - 5.15
<sup>1</sup> 0.495 - 0.505	16.69475 - 16.69525	608 - 614	5.35 - 5.46
2.1735 - 2.1905	16.80425 - 16.80475	960 - 1240	7.25 - 7.75
4.125 - 4.128	25.5 - 25.67	1300 - 1427	8.025 - 8.5
4.17725 - 4.17775	37.5 - 38.25	1435 - 1626.5	9.0 - 9.2
4.20725 - 4.20775	73 - 74.6	1645.5 - 1646.5	9.3 - 9.5
6.215 - 6.218	74.8 - 75.2	1660 - 1710	10.6 - 12.7
6.26775 - 6.26825	108 - 121.94	1718.8 - 1722.2	13.25 - 13.4
6.31175 - 6.31225	123 - 138	2200 - 2300	14.47 - 14.5
8.291 - 8.294	149.9 - 150.05	2310 - 2390	15.35 - 16.2
8.362 - 8.366	156.52475 - 156.52525	2483.5 - 2500	17.7 - 21.4
8.37625 - 8.38675	156.7 - 156.9	2655 - 2900	22.01 - 23.12
8.41425 - 8.41475	162.0125 - 167.17	3260 - 3267	23.6 - 24.0
12.29 - 12.293	167.72 - 173.2	3332 - 3339	31.2 - 31.8
12.51975 - 12.52025	240 - 285	3345.8 - 3338	36.43 - 36.5
12.57675 - 12.57725	322 - 335.4	3600 - 4400	( <sup>2</sup> )
13.36 - 13.41			

**Remark:**

1. <sup>1</sup> Until February 1, 1999, this restricted band shall be 0.490-0.510 MHz.
2. <sup>2</sup> Above 38.6

(2) According to § 15.205 (b) Except as provided in paragraphs (d) and (e) of this section, the field strength of emissions appearing within these frequency bands shall not exceed the limits shown in §15.209. At frequencies equal to or less than 1000 MHz, compliance with the limits in §15.209 shall be demonstrated using measurement instrumentation employing a CISPR quasi-peak detector. Above 1000 MHz, compliance with the emission limits in §15.209 shall be demonstrated based on the average value of the measured emissions. The provisions in §15.35 apply to these measurements.

(3) According to § 15.209 (a) Except as provided elsewhere in this Subpart, the emissions from an intentional radiator shall not exceed the field strength levels specified in the following table :

Frequency (MHz)	Field Strength (microvolts/meter)	Measurement Distance (meters)
0.009 – 0.490	2400/F(KHz)	300
0.490 – 1.705	24000/F(KHz)	30
1.705 – 30.0	30	30
30 - 88	100 **	3
88 - 216	150 **	3
216 - 960	200 **	3
Above 960	500	3

**Remark:** \*\*Except as provided in paragraph (g), fundamental emissions from intentional radiators operating under this Section shall not be located in the frequency bands 54-72 MHz, 76-88 MHz, 174-216 MHz or 470-806 MHz. However, operation within these frequency bands is permitted under other sections of this Part, e.g., Sections 15.231 and 15.241.

(4) According to § 15.209 (b) In the emission table above, the tighter limit applies at the band edges.

**TEST EQUIPMENT**

**Radiated Emission / 966Chamber\_C**

Name of Equipment	Manufacture	Model	Serial Number	Calibration Due
Spectrum Analyzer	Agilent	E4446A	MY45280064	03/26/2016
EMI Test Receiver	ROHDE & SCHWARZ	ESCI	101387	10/05/2015
Bi-log Antenna	TESEQ	CBL 6112D	35404	02/24/2016
Double-Ridged Waveguide Horn	ETS-LINDGREN	3117	00078732	07/23/2015
Horn Antenna	COM-POWER	AH-840	03077	12/17/2015
Pre-Amplifier	EMCI	EMC001625	980243	04/12/2016
Pre-Amplifier	COM-POWER	PAM-118A	551043	04/12/2016
Notch Filters Band Reject	Micro-Tronics	BRM50702-01	009	N.C.R
LOOP Antenna	EMCO	6502	8905-2356	09/23/2015
Band Reject Filter	Micro-Tronics	BRC50703-01	004	N.C.R.
Band Reject Filter	Micro-Tronics	BRC50704-01	004	N.C.R.
Band Reject Filter	Micro-Tronics	BRC50705-01	007	N.C.R.

**Remark:** 1. Each piece of equipment is scheduled for calibration once a year.  
 2. N.C.R = No Calibration Request.

**TEST SETUP**

The diagram below shows the test setup that is utilized to make the measurements for emission below 1GHz.

**9kHz ~ 30MHz**

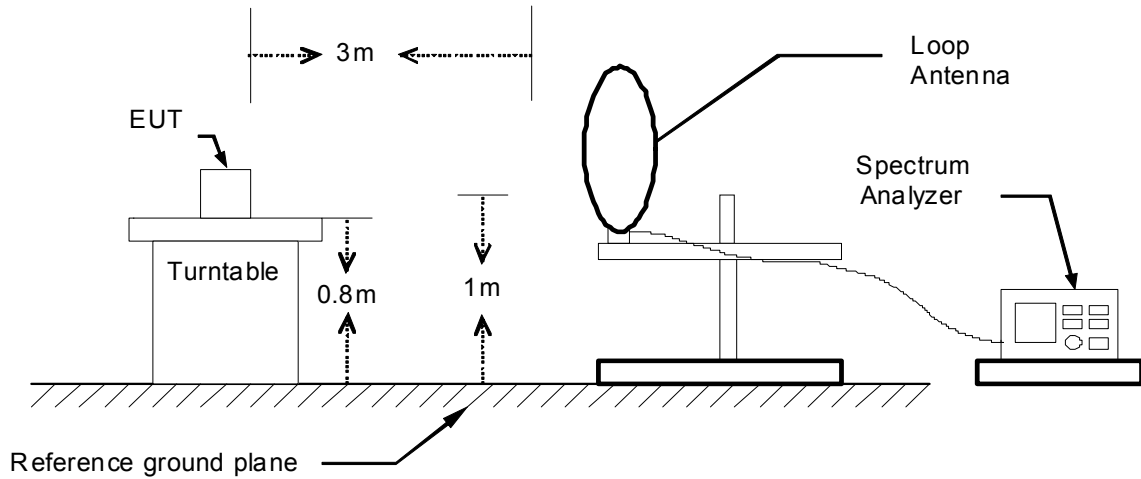

**30MHz ~ 1GHz**

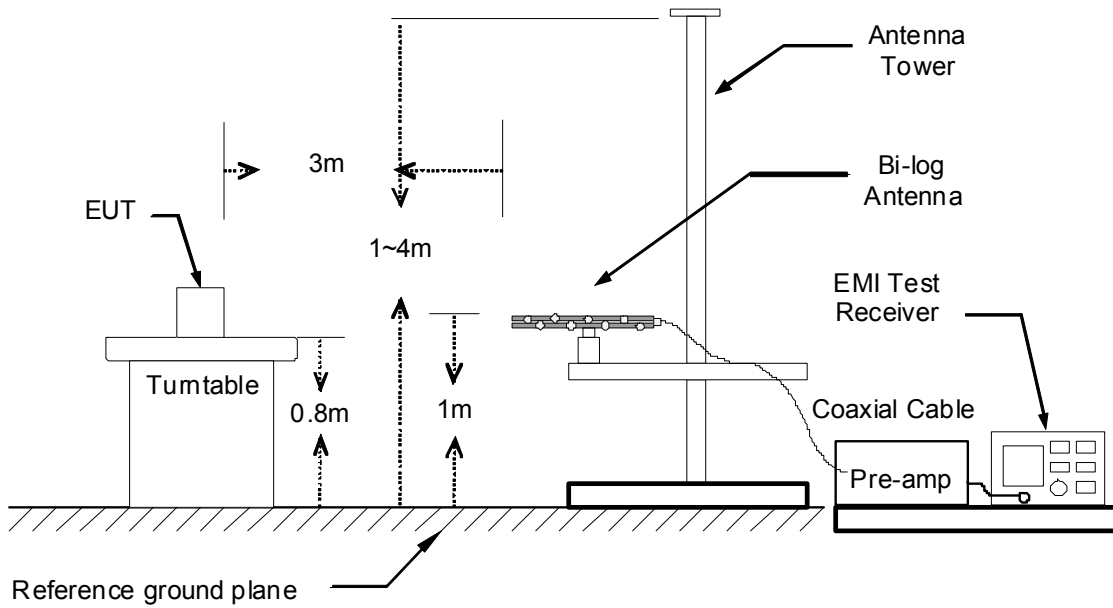

The diagram below shows the test setup that is utilized to make the measurements for emission above 1GHz.

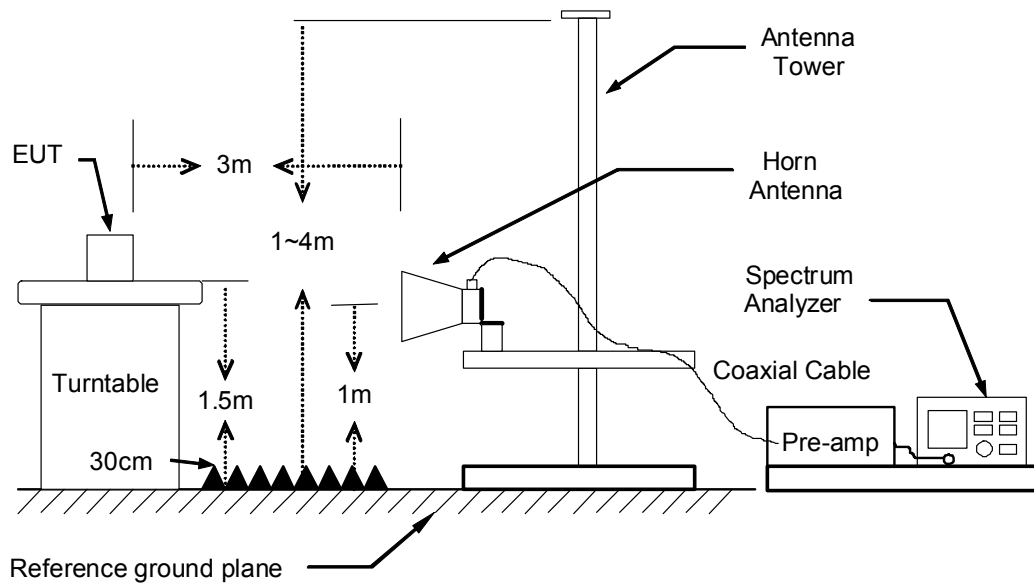

### **TEST PROCEDURE**

1. The EUT was placed on the top of a rotating table 0.8 and 1.5 meters above the ground. The table was rotated 360 degrees to determine the position of the highest radiation.
2. While measuring the radiated emission below 1GHz, the EUT was set 3 meters away from the interference-receiving antenna, which was mounted on the top of a variable-height antenna tower. While measuring the radiated emission above 1GHz, the EUT was set 3 meters away from the interference-receiving antenna.
3. The antenna is a broadband antenna, and its height is varied from one meter to four meters above the ground to determine the maximum value of the field strength. Both horizontal and vertical polarization of the antenna are set to make the measurement.
4. For each suspected emission, the EUT was arranged to its worst case and then the antenna was tuned to heights from 1 meter to 4 meters and the table was turned from 0 degrees to 360 degrees to find the maximum reading.
5. The test-receiver system was set to Peak Detect Function and Specified Bandwidth with Maximum Hold Mode.
6. If the emission level of the EUT in peak mode was 10 dB lower than the limit specified, then testing could be stopped and the peak values of the EUT would be reported. Otherwise the emissions that did not have 10 dB margin would be re-tested one by one using peak, quasi-peak or average method as specified and then reported in a data sheet.

#### **Remark :**

1. The resolution bandwidth and video bandwidth of test receiver/spectrum analyzer is 120 KHz for Peak detection (PK) and Quasi-peak detection (QP) at frequency below 1GHz.
2. The resolution bandwidth and video bandwidth of test receiver/spectrum analyzer is 1 MHz for Peak detection and frequency above 1GHz.
3. The resolution bandwidth of test receiver/spectrum analyzer is 1 MHz and the video bandwidth is 10 Hz for Average detection (AV) at frequency above 1GHz.

**TEST RESULTS**

**Below 1 GHz (9kHz ~ 30MHz)**

No emission found between lowest internal used/generated frequency to 30MHz.

**Below 1 GHz (30MHz ~ 1GHz)**

<b>Product Name</b>	Computer	<b>Test By</b>	Waternil Guan
<b>Test Model</b>	POC127	<b>Test Date</b>	2015/06/02
<b>Test Mode</b>	TX Mode	<b>Temp. &amp; Humidity</b>	26°C, 52%

966 Chamber\_C at 3Meter / Horizontal

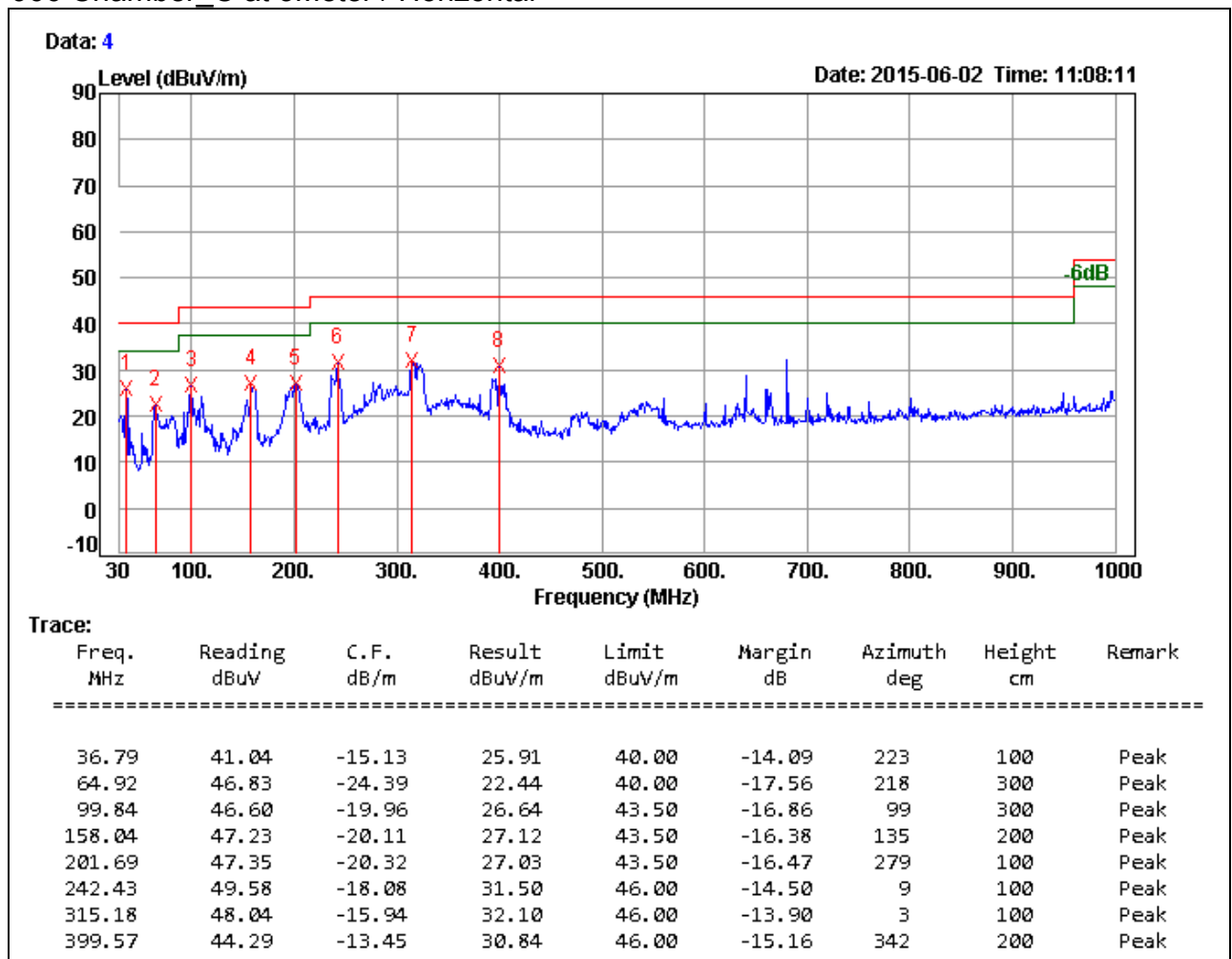

**Remark:**

1. Quasi-peak test would be performed if the peak result were greater than the quasi-peak limit.
2. Correction Factor (dB/m) = Antenna Factor (dB/m) + Cable Loss (dB) – PreAmp.Gain (dB)
3. Result (dBUV/m) = Reading (dBUV) + Correction Factor (dB/m)
4. Margin (dB) = Remark result (dBUV/m) - Quasi-peak limit (dBUV/m).

<b>Product Name</b>	Computer	<b>Test By</b>	Waternil Guan
<b>Test Model</b>	POC127	<b>Test Date</b>	2015/06/02
<b>Test Mode</b>	TX Mode	<b>Temp. &amp; Humidity</b>	26°C, 52%

966 Chamber\_C at 3Meter / Vertical

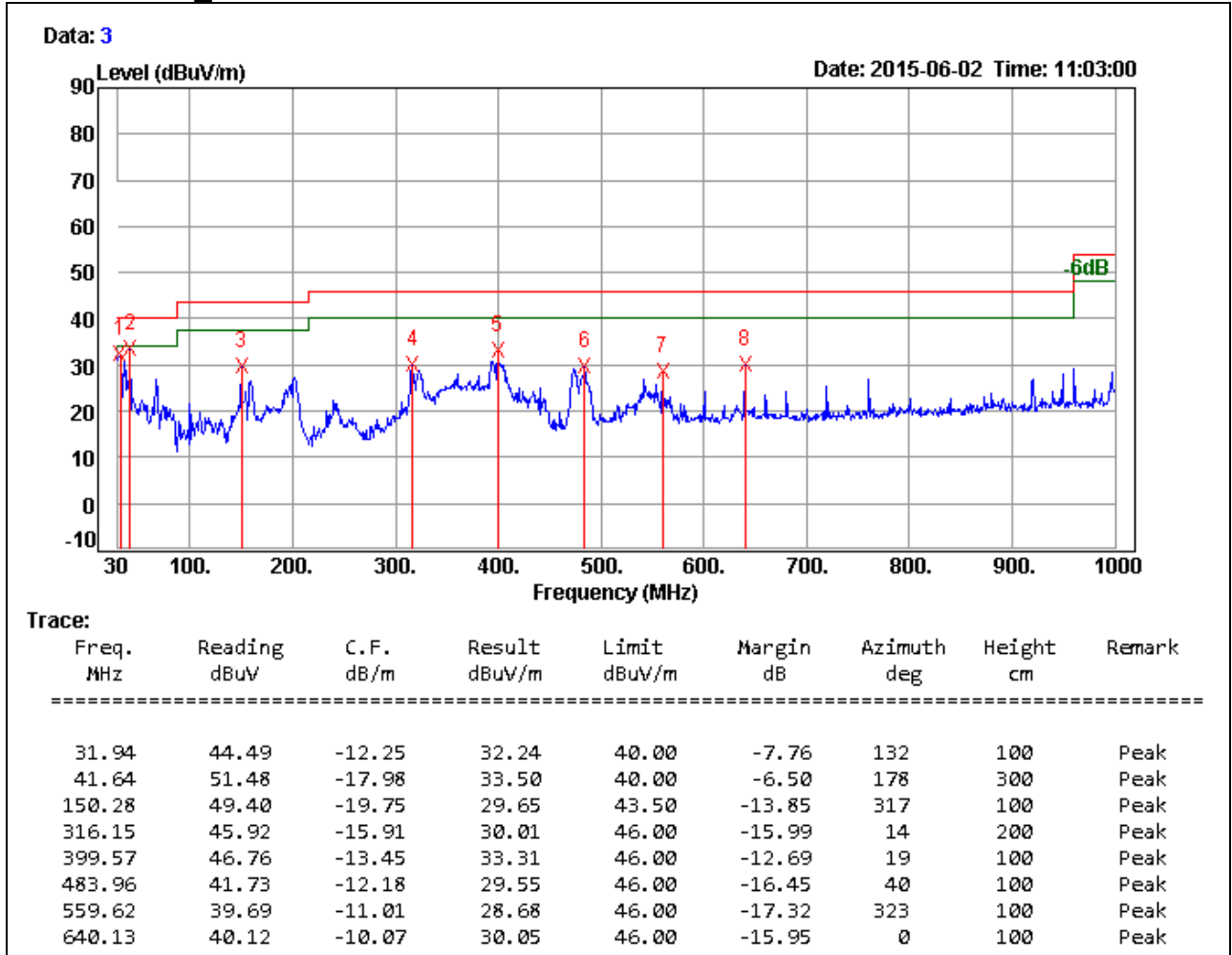

**Remark:**

1. Quasi-peak test would be performed if the peak result were greater than the quasi-peak limit.
2. Correction Factor (dB/m) = Antenna Factor (dB/m) + Cable Loss (dB) – PreAmp.Gain (dB)
3. Result (dBuV/m) = Reading (dBuV) + Correction Factor (dB/m)
4. Margin (dB) = Remark result (dBuV/m) - Quasi-peak limit (dBuV/m).

**Above 1 GHz**

<b>Product Name</b>	Computer	<b>Test By</b>	Waternil Guan
<b>Test Model</b>	POC127	<b>Test Date</b>	2015/06/05
<b>Test Mode</b>	UNII Band 1/ IEEE 802.11a TX / CH Low	<b>Temp. &amp; Humidity</b>	26°C, 52%

966 Chamber\_C at 3Meter / Horizontal

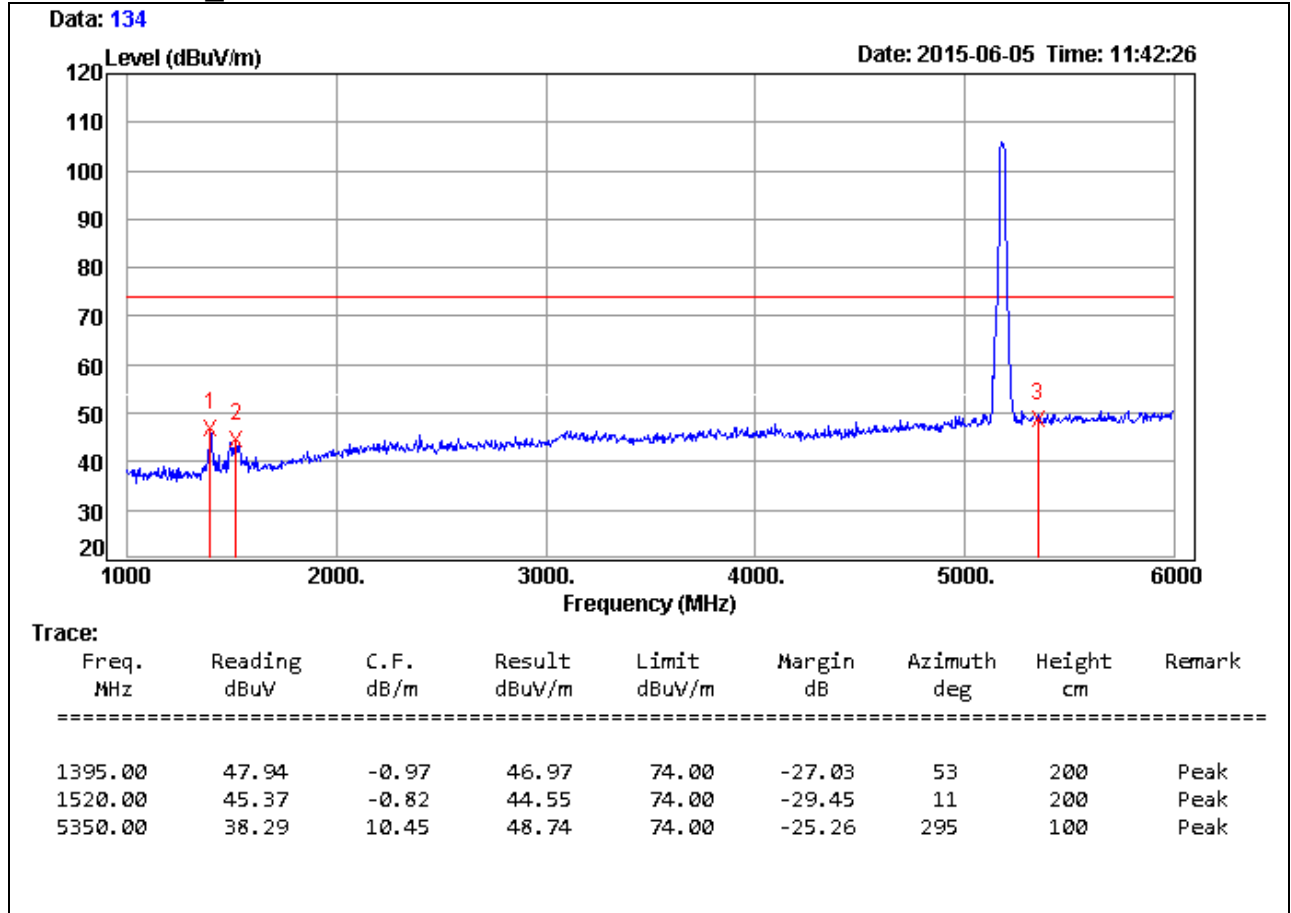

**Remark:**

1. Measuring frequencies from 1 GHz to the 10th harmonic of highest fundamental frequency.
2. Average test would be performed if the peak result were greater than the average limit.
3. Measurements above show only up to 6 maximum emissions noted, or would be lesser, with " N/A " remark, if no specific emissions from the EUT are recorded (ie: margin>20dB from the applicable limit) and considered that's already beyond the background noise floor.
4. Result = Reading + Correction Factor  
Margin = Result - Limit  
Remark Peak = Result(PK) - Limit(PK)  
Remark AVG = Result(AV) - Limit(AV)



<b>Product Name</b>	Computer	<b>Test By</b>	Waternil Guan
<b>Test Model</b>	POC127	<b>Test Date</b>	2015/06/04
<b>Test Mode</b>	UNII Band 1/ IEEE 802.11a TX / CH Low	<b>Temp. &amp; Humidity</b>	26°C, 52%

966 Chamber\_C at 3Meter / Horizontal

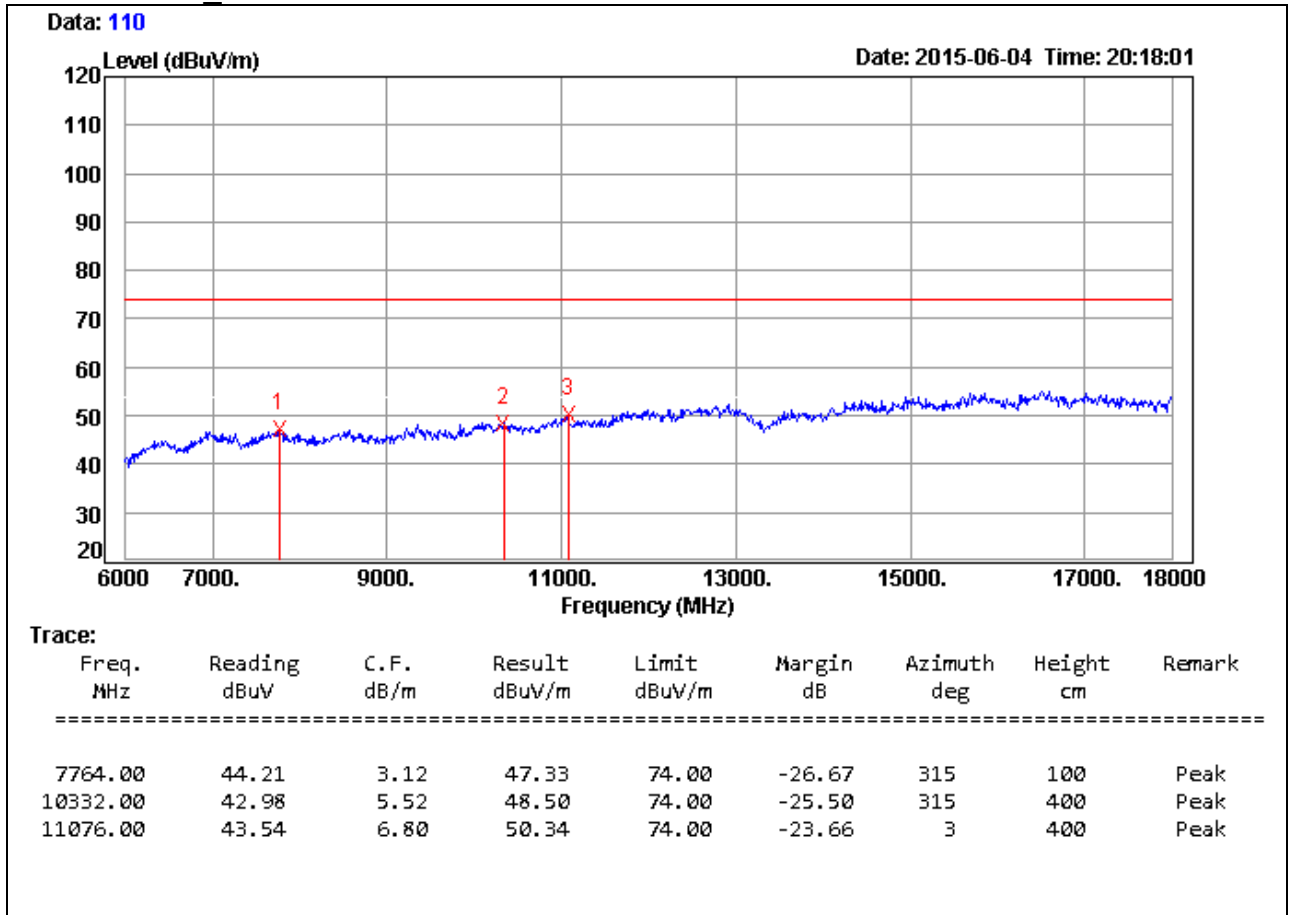

**Remark:**

1. Measuring frequencies from 1 GHz to the 10th harmonic of highest fundamental frequency.
2. Average test would be performed if the peak result were greater than the average limit.
3. Measurements above show only up to 6 maximum emissions noted, or would be lesser, with " N/A " remark, if no specific emissions from the EUT are recorded (ie: margin>20dB from the applicable limit) and considered that's already beyond the background noise floor.
4. Result = Reading + Correction Factor  
Margin = Result - Limit  
Remark Peak = Result(PK) - Limit(PK)  
Remark AVG = Result(AV) - Limit(AV)
5. There is no emission in 18GHz ~ 40GHz.

<b>Product Name</b>	Computer	<b>Test By</b>	Waternil Guan
<b>Test Model</b>	POC127	<b>Test Date</b>	2015/06/05
<b>Test Mode</b>	UNII Band 1/ IEEE 802.11a TX / CH Low	<b>Temp. &amp; Humidity</b>	26°C, 52%

966 Chamber\_C at 3Meter / Vertical

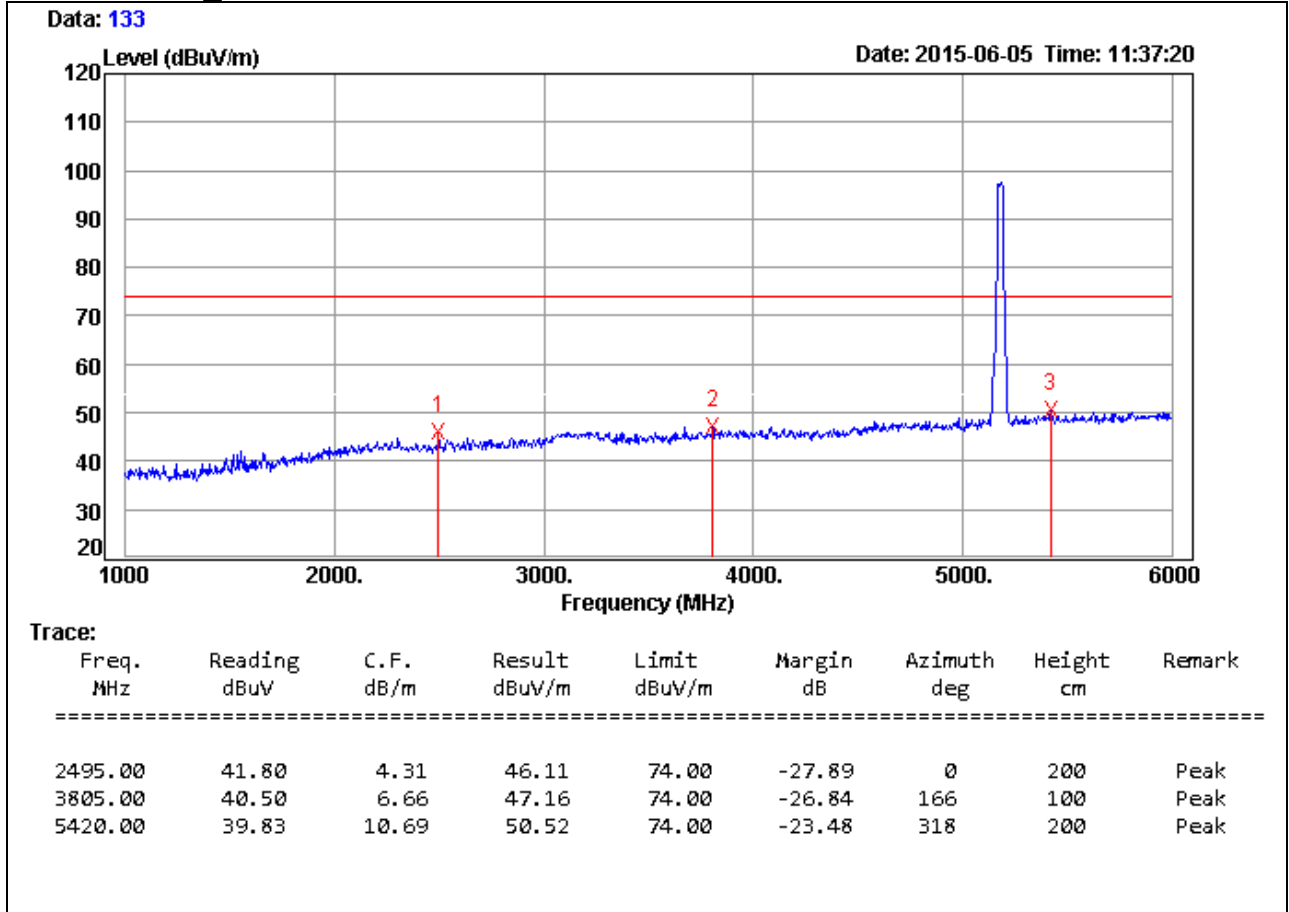

**Remark:**

1. Measuring frequencies from 1 GHz to the 10th harmonic of highest fundamental frequency.
2. Average test would be performed if the peak result were greater than the average limit.
3. Measurements above show only up to 6 maximum emissions noted, or would be lesser, with " N/A " remark, if no specific emissions from the EUT are recorded (ie: margin>20dB from the applicable limit) and considered that's already beyond the background noise floor.
4. Result = Reading + Correction Factor  
 Margin = Result – Limit  
 Remark Peak = Result(PK) – Limit(PK)  
 Remark AVG = Result(AV) – Limit(AV)

<b>Product Name</b>	Computer	<b>Test By</b>	Waternil Guan
<b>Test Model</b>	POC127	<b>Test Date</b>	2015/06/04
<b>Test Mode</b>	UNII Band 1/ IEEE 802.11a TX / CH Low	<b>Temp. &amp; Humidity</b>	26°C, 52%

966 Chamber\_C at 3Meter / Vertical

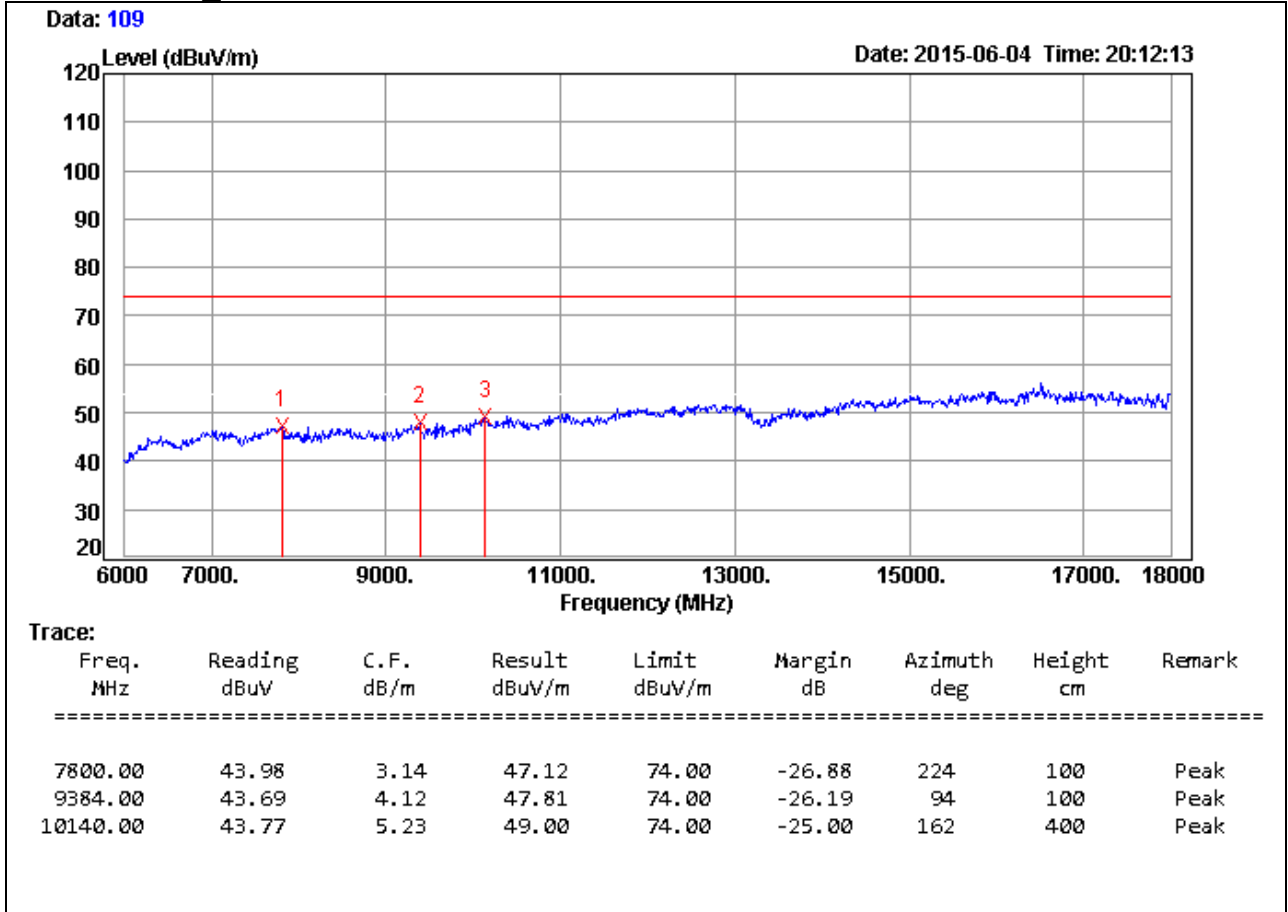

**Remark:**

1. Measuring frequencies from 1 GHz to the 10th harmonic of highest fundamental frequency.
2. Average test would be performed if the peak result were greater than the average limit.
3. Measurements above show only up to 6 maximum emissions noted, or would be lesser, with " N/A " remark, if no specific emissions from the EUT are recorded (ie: margin>20dB from the applicable limit) and considered that's already beyond the background noise floor.
4. Result = Reading + Correction Factor  
Margin = Result - Limit  
Remark Peak = Result(PK) - Limit(PK)  
Remark AVG = Result(AV) - Limit(AV)
5. There is no emission in 18GHz ~ 40GHz.

<b>Product Name</b>	Computer	<b>Test By</b>	Waternil Guan
<b>Test Model</b>	POC127	<b>Test Date</b>	2015/06/05
<b>Test Mode</b>	UNII Band 1/ IEEE 802.11a TX / CH Middle	<b>Temp. &amp; Humidity</b>	26°C, 52%

966 Chamber\_C at 3Meter / Horizontal

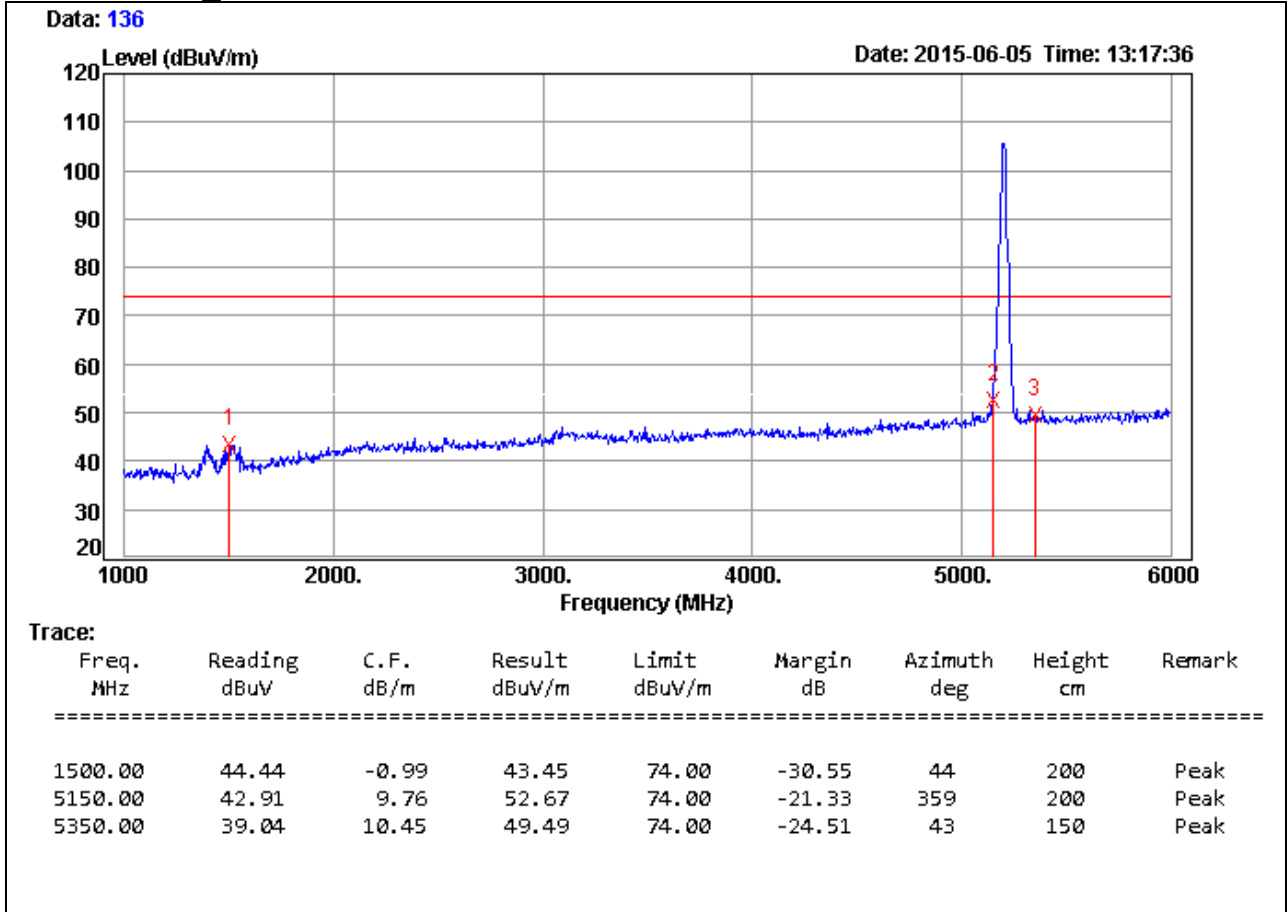

**Remark:**

1. Measuring frequencies from 1 GHz to the 10th harmonic of highest fundamental frequency.
2. Average test would be performed if the peak result were greater than the average limit.
3. Measurements above show only up to 6 maximum emissions noted, or would be lesser, with " N/A " remark, if no specific emissions from the EUT are recorded (ie: margin>20dB from the applicable limit) and considered that's already beyond the background noise floor.
4. Result = Reading + Correction Factor  
 Margin = Result - Limit  
 Remark Peak = Result(PK) - Limit(PK)  
 Remark AVG = Result(AV) - Limit(AV)

<b>Product Name</b>	Computer	<b>Test By</b>	Waternil Guan
<b>Test Model</b>	POC127	<b>Test Date</b>	2015/06/04
<b>Test Mode</b>	UNII Band 1/ IEEE 802.11a TX / CH Middle	<b>Temp. &amp; Humidity</b>	26°C, 52%

966 Chamber\_C at 3Meter / Horizontal

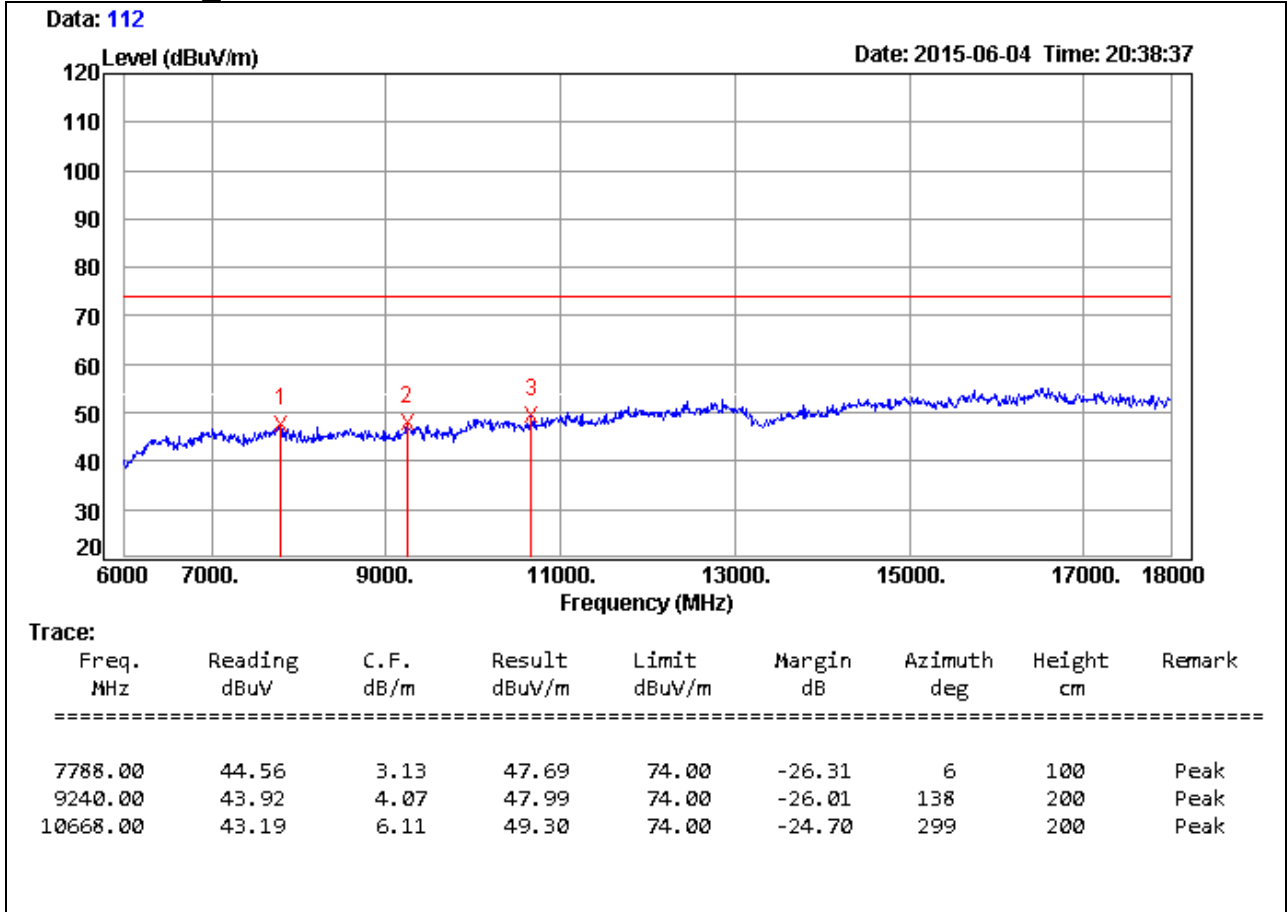

**Remark:**

1. Measuring frequencies from 1 GHz to the 10th harmonic of highest fundamental frequency.
2. Average test would be performed if the peak result were greater than the average limit.
3. Measurements above show only up to 6 maximum emissions noted, or would be lesser, with " N/A " remark, if no specific emissions from the EUT are recorded (ie: margin>20dB from the applicable limit) and considered that's already beyond the background noise floor.
4. Result = Reading + Correction Factor  
 Margin = Result - Limit  
 Remark Peak = Result(PK) - Limit(PK)  
 Remark AVG = Result(AV) - Limit(AV)
5. There is no emission in 18GHz ~ 40GHz.

<b>Product Name</b>	Computer	<b>Test By</b>	Waternil Guan
<b>Test Model</b>	POC127	<b>Test Date</b>	2015/06/05
<b>Test Mode</b>	UNII Band 1/ IEEE 802.11a TX / CH Middle	<b>Temp. &amp; Humidity</b>	26°C, 52%

966 Chamber\_C at 3Meter / Vertical

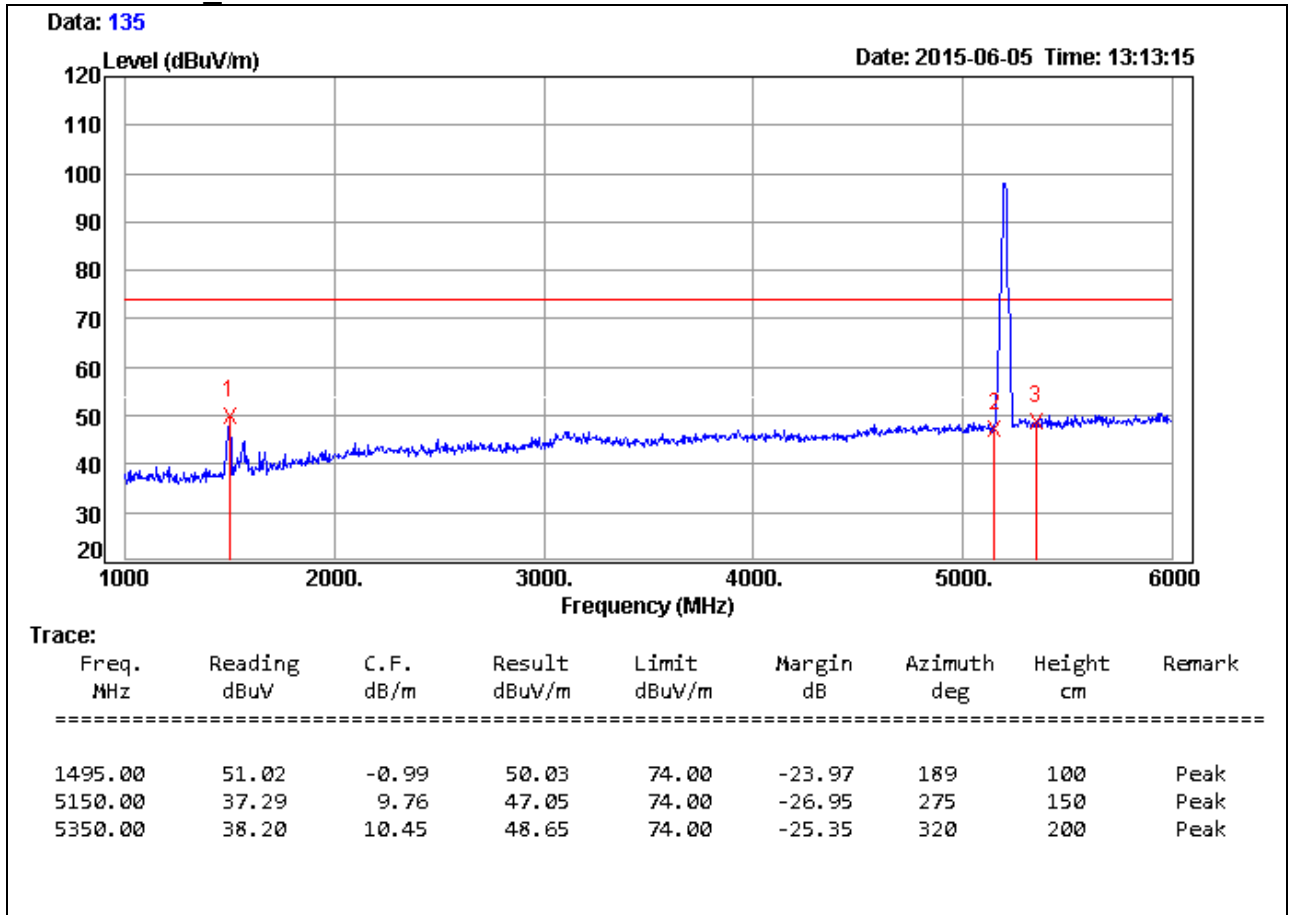

**Remark:**

1. Measuring frequencies from 1 GHz to the 10th harmonic of highest fundamental frequency.
2. Average test would be performed if the peak result were greater than the average limit.
3. Measurements above show only up to 6 maximum emissions noted, or would be lesser, with " N/A " remark, if no specific emissions from the EUT are recorded (ie: margin>20dB from the applicable limit) and considered that's already beyond the background noise floor.
4. Result = Reading + Correction Factor  
 Margin = Result - Limit  
 Remark Peak = Result(PK) - Limit(PK)  
 Remark AVG = Result(AV) - Limit(AV)

<b>Product Name</b>	Computer	<b>Test By</b>	Waternil Guan
<b>Test Model</b>	POC127	<b>Test Date</b>	2015/06/04
<b>Test Mode</b>	UNII Band 1/ IEEE 802.11a TX / CH Middle	<b>Temp. &amp; Humidity</b>	26°C, 52%

966 Chamber\_C at 3Meter / Vertical

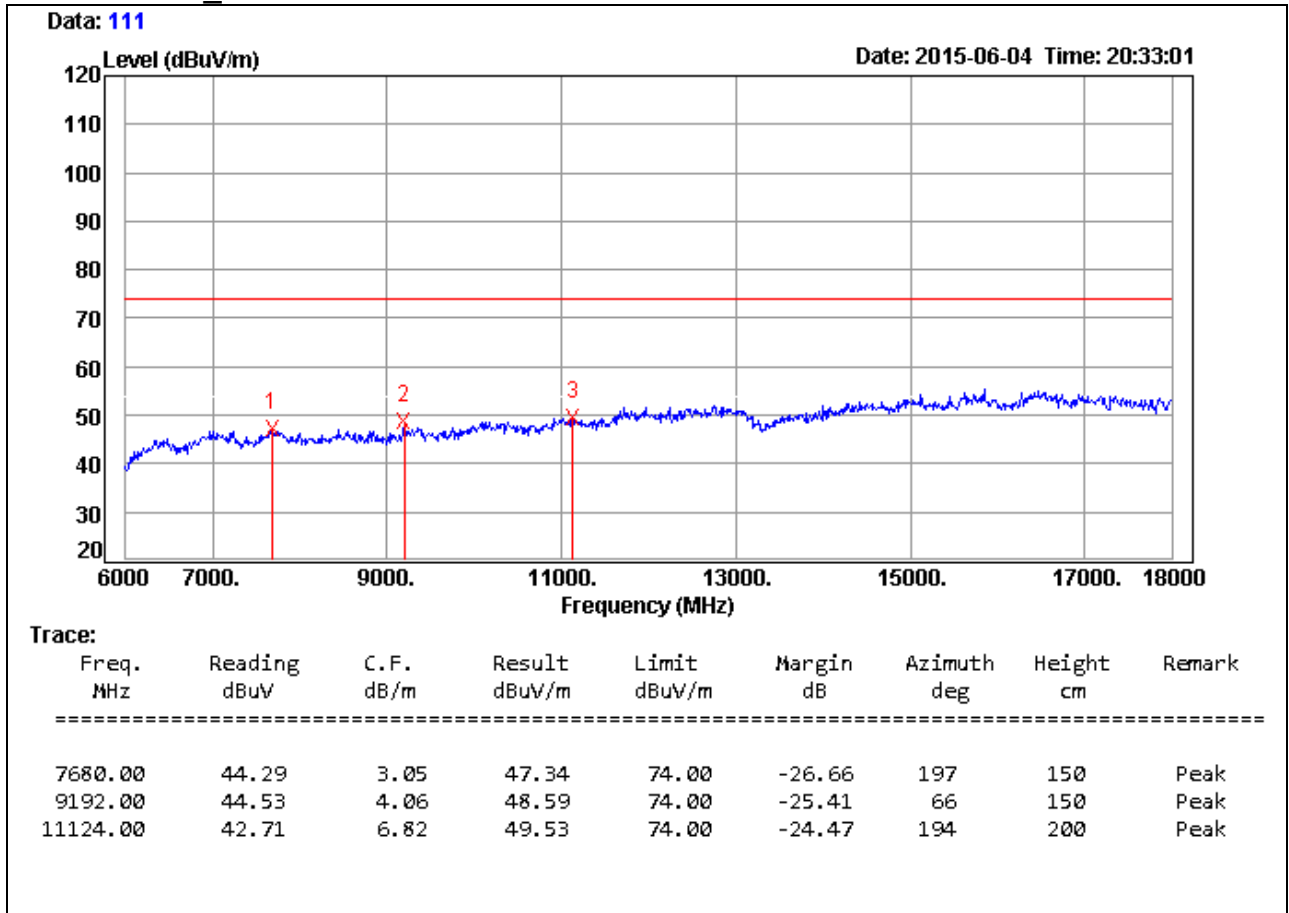

**Remark:**

1. Measuring frequencies from 1 GHz to the 10th harmonic of highest fundamental frequency.
2. Average test would be performed if the peak result were greater than the average limit.
3. Measurements above show only up to 6 maximum emissions noted, or would be lesser, with " N/A " remark, if no specific emissions from the EUT are recorded (ie: margin>20dB from the applicable limit) and considered that's already beyond the background noise floor.
4. Result = Reading + Correction Factor  
Margin = Result - Limit  
Remark Peak = Result(PK) - Limit(PK)  
Remark AVG = Result(AV) - Limit(AV)
5. There is no emission in 18GHz ~ 40GHz.

<b>Product Name</b>	Computer	<b>Test By</b>	Waternil Guan
<b>Test Model</b>	POC127	<b>Test Date</b>	2015/06/05
<b>Test Mode</b>	UNII Band 1/ IEEE 802.11a TX / CH High	<b>Temp. &amp; Humidity</b>	26°C, 52%

966 Chamber\_C at 3Meter / Horizontal

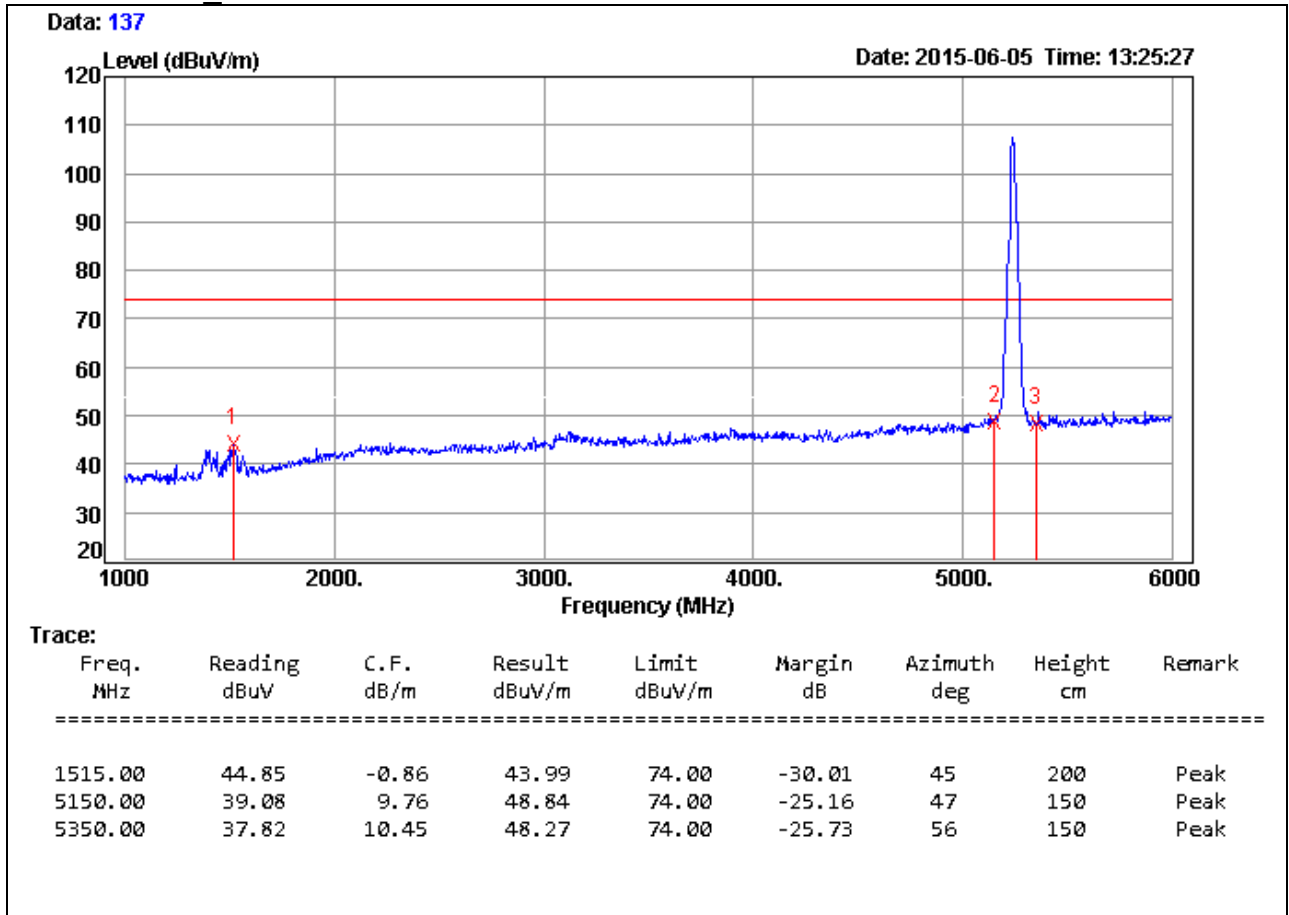

**Remark:**

1. Measuring frequencies from 1 GHz to the 10th harmonic of highest fundamental frequency.
2. Average test would be performed if the peak result were greater than the average limit.
3. Measurements above show only up to 6 maximum emissions noted, or would be lesser, with " N/A " remark, if no specific emissions from the EUT are recorded (ie: margin>20dB from the applicable limit) and considered that's already beyond the background noise floor.
4.  $Result = Reading + Correction\ Factor$   
 $Margin = Result - Limit$   
 $Remark\ Peak = Result(PK) - Limit(PK)$   
 $Remark\ AVG = Result(AV) - Limit(AV)$



<b>Product Name</b>	Computer	<b>Test By</b>	Waternil Guan
<b>Test Model</b>	POC127	<b>Test Date</b>	2015/06/04
<b>Test Mode</b>	UNII Band 1/ IEEE 802.11a TX / CH High	<b>Temp. &amp; Humidity</b>	26°C, 52%

966 Chamber\_C at 3Meter / Horizontal

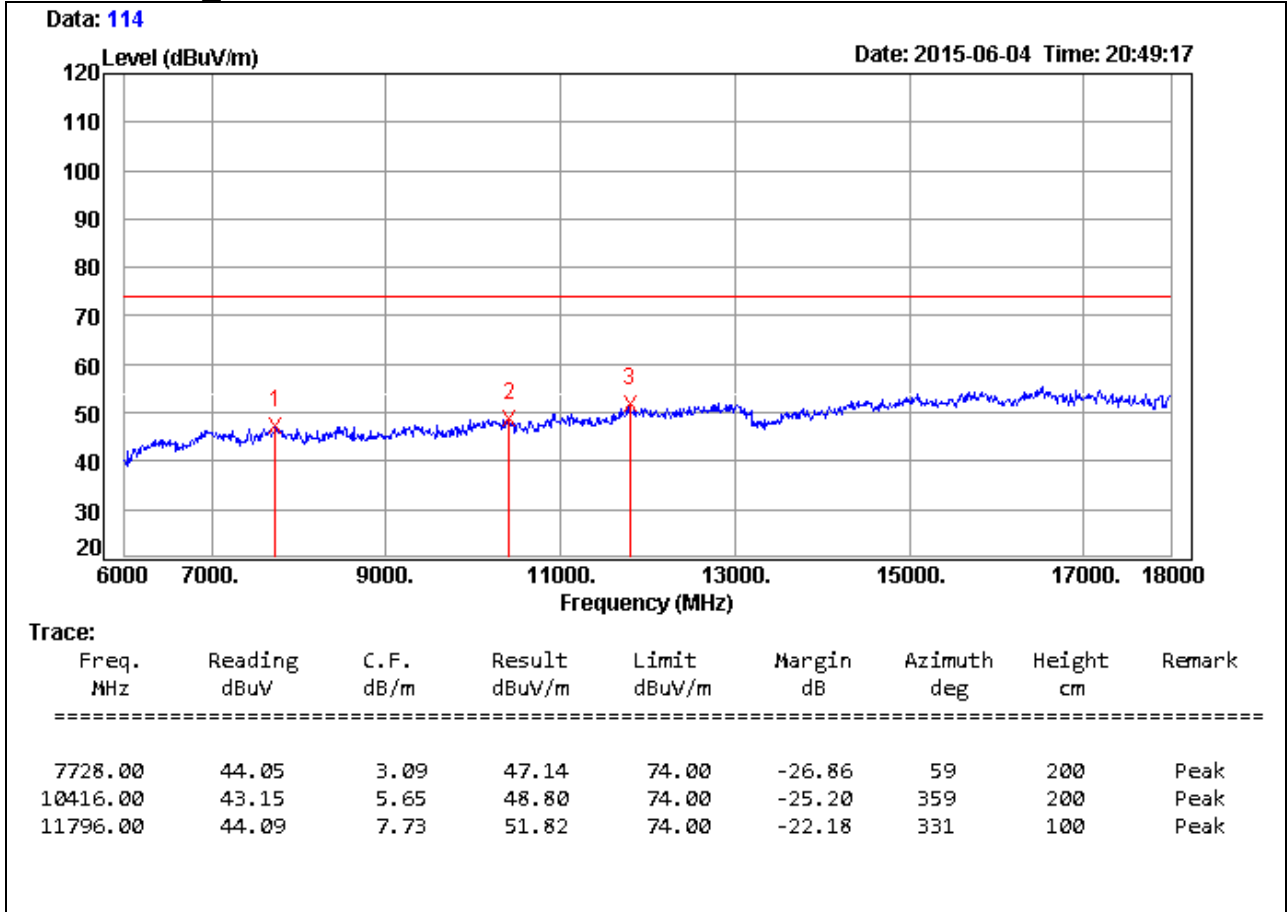

**Remark:**

1. Measuring frequencies from 1 GHz to the 10th harmonic of highest fundamental frequency.
2. Average test would be performed if the peak result were greater than the average limit.
3. Measurements above show only up to 6 maximum emissions noted, or would be lesser, with " N/A " remark, if no specific emissions from the EUT are recorded (ie: margin>20dB from the applicable limit) and considered that's already beyond the background noise floor.
4. Result = Reading + Correction Factor  
Margin = Result - Limit  
Remark Peak = Result(PK) - Limit(PK)  
Remark AVG = Result(AV) - Limit(AV)
5. There is no emission in 18GHz ~ 40GHz.

<b>Product Name</b>	Computer	<b>Test By</b>	Waternil Guan
<b>Test Model</b>	POC127	<b>Test Date</b>	2015/06/05
<b>Test Mode</b>	UNII Band 1/ IEEE 802.11a TX / CH High	<b>Temp. &amp; Humidity</b>	26°C, 52%

966 Chamber\_C at 3Meter / Vertical

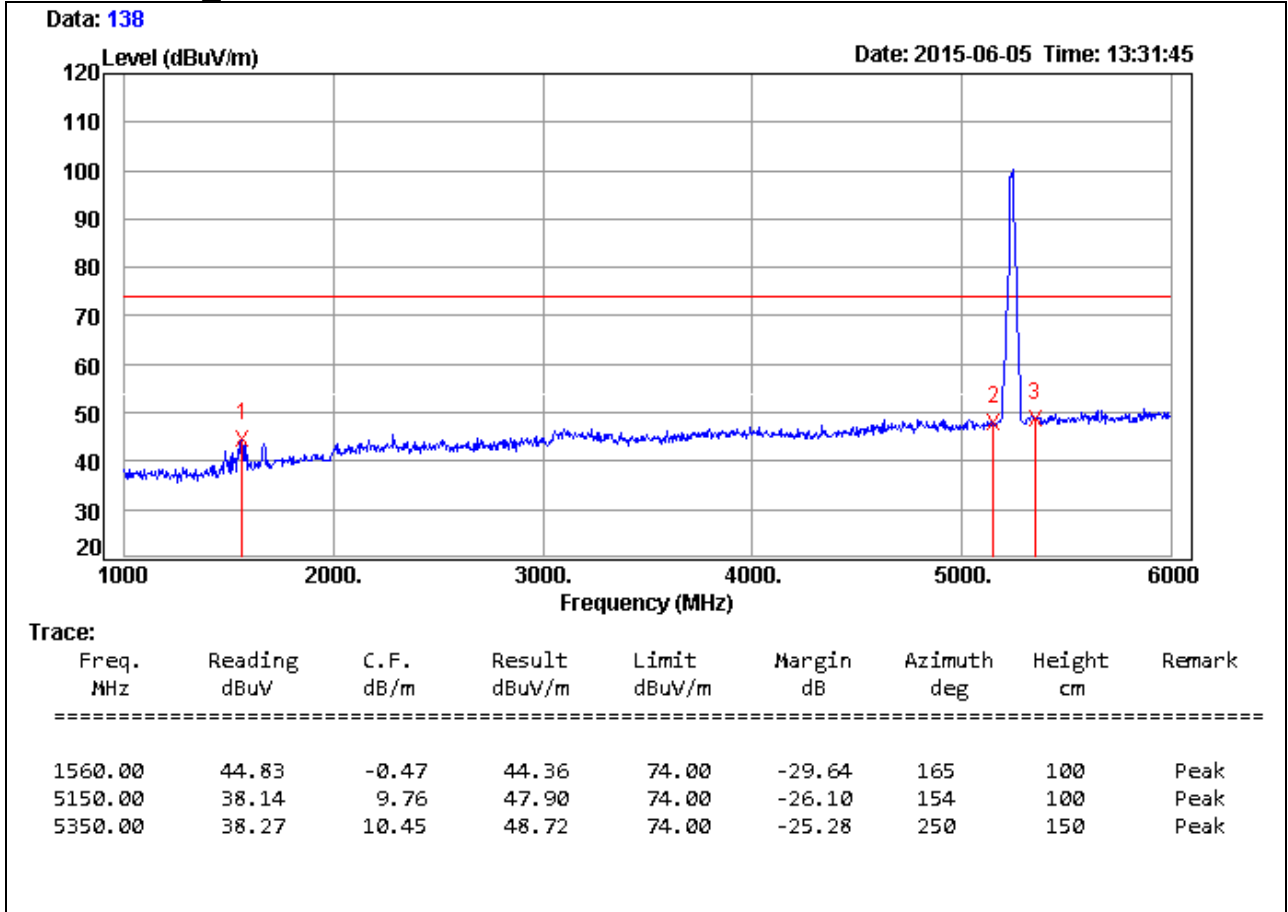

**Remark:**

1. Measuring frequencies from 1 GHz to the 10th harmonic of highest fundamental frequency.
2. Average test would be performed if the peak result were greater than the average limit.
3. Measurements above show only up to 6 maximum emissions noted, or would be lesser, with " N/A " remark, if no specific emissions from the EUT are recorded (ie: margin>20dB from the applicable limit) and considered that's already beyond the background noise floor.
4. Result = Reading + Correction Factor  
 Margin = Result - Limit  
 Remark Peak = Result(PK) - Limit(PK)  
 Remark AVG = Result(AV) - Limit(AV)

<b>Product Name</b>	Computer	<b>Test By</b>	Waternil Guan
<b>Test Model</b>	POC127	<b>Test Date</b>	2015/06/04
<b>Test Mode</b>	UNII Band 1/ IEEE 802.11a TX / CH High	<b>Temp. &amp; Humidity</b>	26°C, 52%

966 Chamber\_C at 3Meter / Vertical

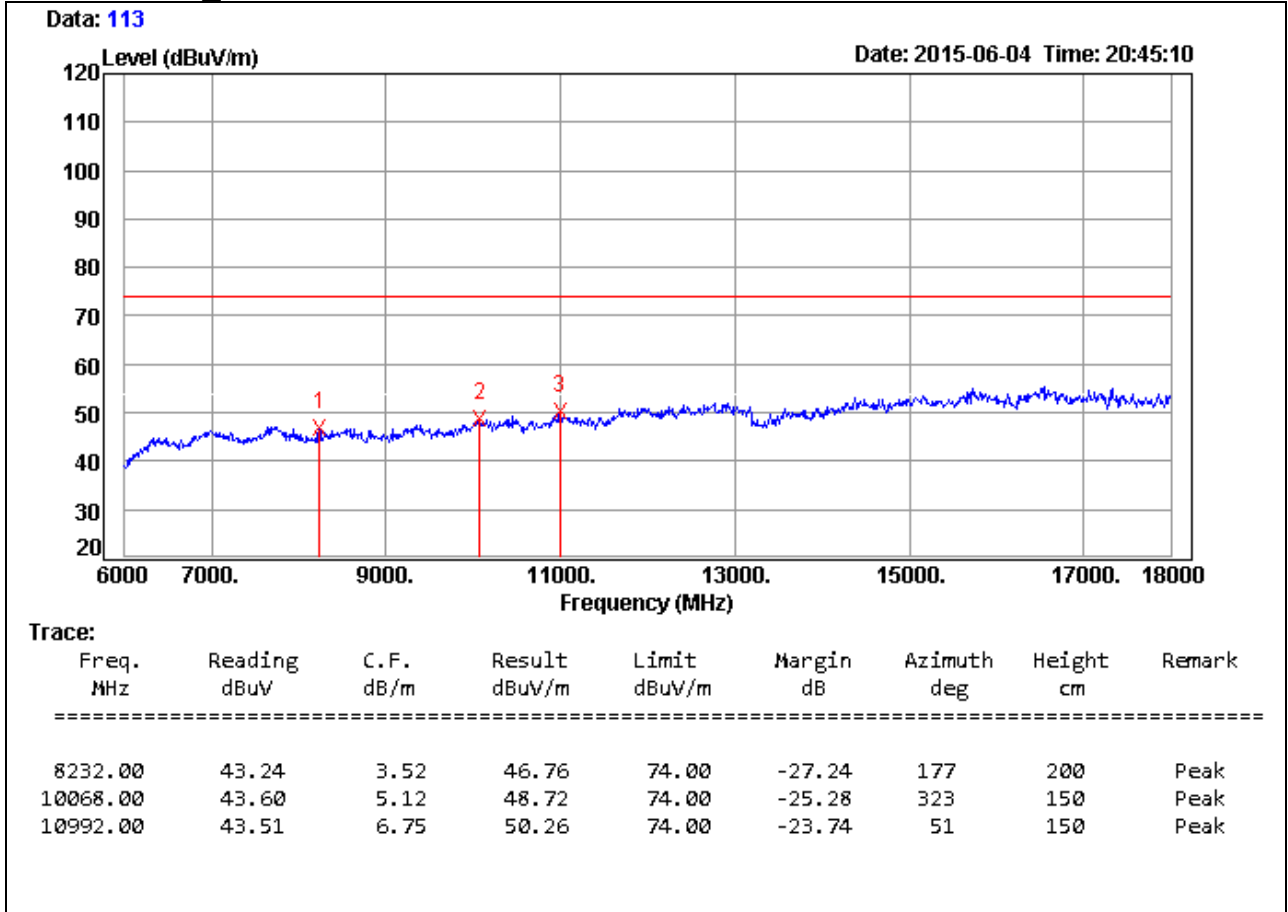

**Remark:**

1. Measuring frequencies from 1 GHz to the 10th harmonic of highest fundamental frequency.
2. Average test would be performed if the peak result were greater than the average limit.
3. Measurements above show only up to 6 maximum emissions noted, or would be lesser, with " N/A " remark, if no specific emissions from the EUT are recorded (ie: margin>20dB from the applicable limit) and considered that's already beyond the background noise floor.
4. Result = Reading + Correction Factor  
 Margin = Result - Limit  
 Remark Peak = Result(PK) - Limit(PK)  
 Remark AVG = Result(AV) - Limit(AV)
5. There is no emission in 18GHz ~ 40GHz.

<b>Product Name</b>	Computer	<b>Test By</b>	Waternil Guan
<b>Test Model</b>	POC127	<b>Test Date</b>	2015/06/09
<b>Test Mode</b>	UNII Band 1/ IEEE 802.11an HT20 TX / CH Low	<b>Temp. &amp; Humidity</b>	26°C, 52%

966 Chamber\_C at 3Meter / Horizontal

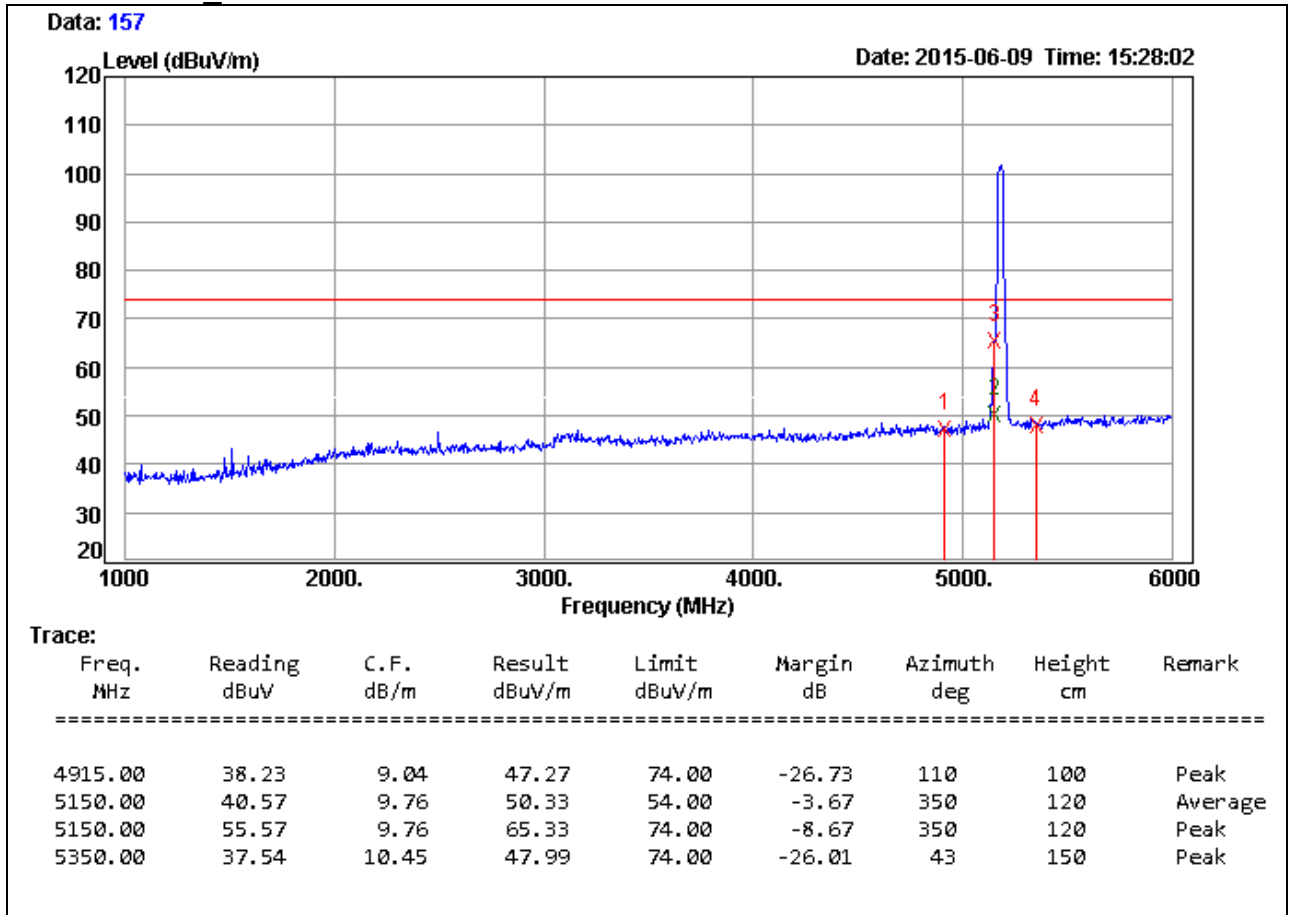

**Remark:**

1. Measuring frequencies from 1 GHz to the 10th harmonic of highest fundamental frequency.
2. Average test would be performed if the peak result were greater than the average limit.
3. Measurements above show only up to 6 maximum emissions noted, or would be lesser, with " N/A " remark, if no specific emissions from the EUT are recorded (ie: margin>20dB from the applicable limit) and considered that's already beyond the background noise floor.
4. Result = Reading + Correction Factor  
 Margin = Result - Limit  
 Remark Peak = Result(PK) - Limit(PK)  
 Remark AVG = Result(AV) - Limit(AV)

<b>Product Name</b>	Computer	<b>Test By</b>	Watniril Guan
<b>Test Model</b>	POC127	<b>Test Date</b>	2015/06/10
<b>Test Mode</b>	UNII Band 1/ IEEE 802.11an HT20 TX / CH Low	<b>Temp. &amp; Humidity</b>	26°C, 52%

966 Chamber\_C at 3Meter / Horizontal

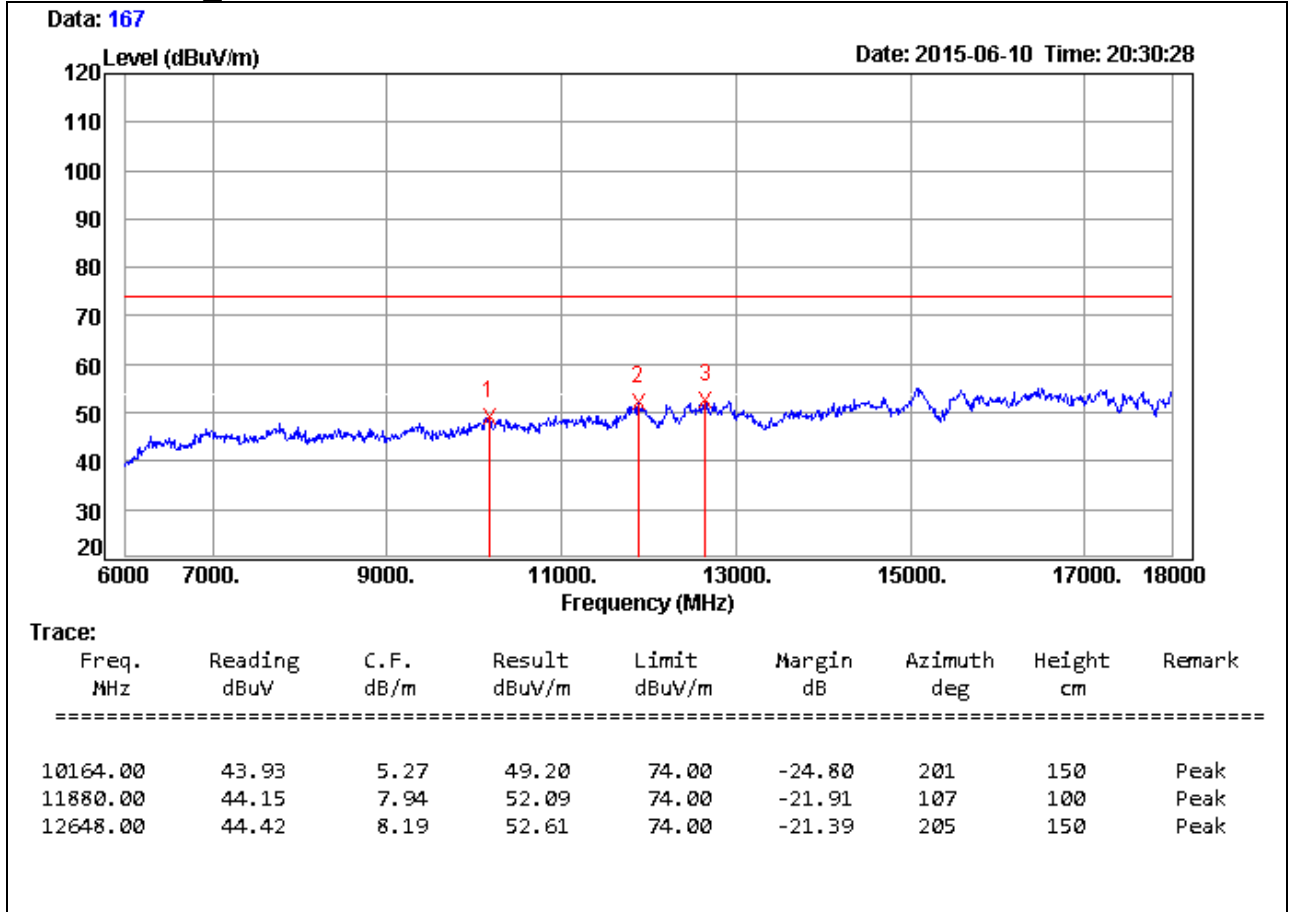

**Remark:**

1. Measuring frequencies from 1 GHz to the 10th harmonic of highest fundamental frequency.
2. Average test would be performed if the peak result were greater than the average limit.
3. Measurements above show only up to 6 maximum emissions noted, or would be lesser, with " N/A " remark, if no specific emissions from the EUT are recorded (ie: margin>20dB from the applicable limit) and considered that's already beyond the background noise floor.
4. Result = Reading + Correction Factor  
Margin = Result - Limit  
Remark Peak = Result(PK) - Limit(PK)  
Remark AVG = Result(AV) - Limit(AV)
5. There is no emission in 18GHz ~ 40GHz.

<b>Product Name</b>	Computer	<b>Test By</b>	Waternil Guan
<b>Test Model</b>	POC127	<b>Test Date</b>	2015/06/09
<b>Test Mode</b>	UNII Band 1/ IEEE 802.11an HT20 TX / CH Low	<b>Temp. &amp; Humidity</b>	26°C, 52%

966 Chamber\_C at 3Meter / Vertical

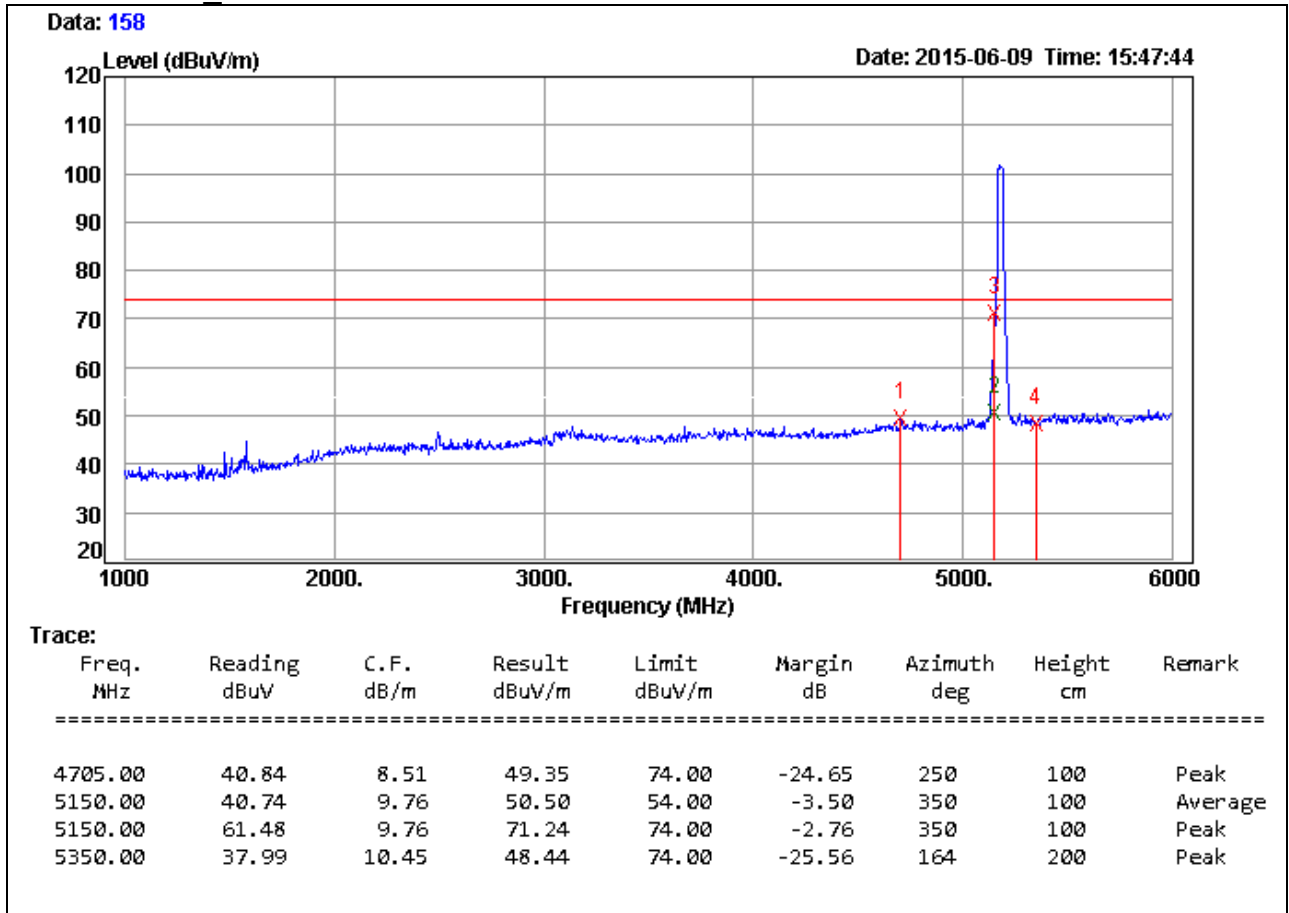

**Remark:**

1. Measuring frequencies from 1 GHz to the 10th harmonic of highest fundamental frequency.
2. Average test would be performed if the peak result were greater than the average limit.
3. Measurements above show only up to 6 maximum emissions noted, or would be lesser, with " N/A " remark, if no specific emissions from the EUT are recorded (ie: margin>20dB from the applicable limit) and considered that's already beyond the background noise floor.
4.  $Result = Reading + Correction\ Factor$   
 $Margin = Result - Limit$   
 $Remark\ Peak = Result(PK) - Limit(PK)$   
 $Remark\ AVG = Result(AV) - Limit(AV)$

<b>Product Name</b>	Computer	<b>Test By</b>	Waternil Guan
<b>Test Model</b>	POC127	<b>Test Date</b>	2015/06/10
<b>Test Mode</b>	UNII Band 1/ IEEE 802.11an HT20 TX / CH Low	<b>Temp. &amp; Humidity</b>	26°C, 52%

966 Chamber\_C at 3Meter / Vertical

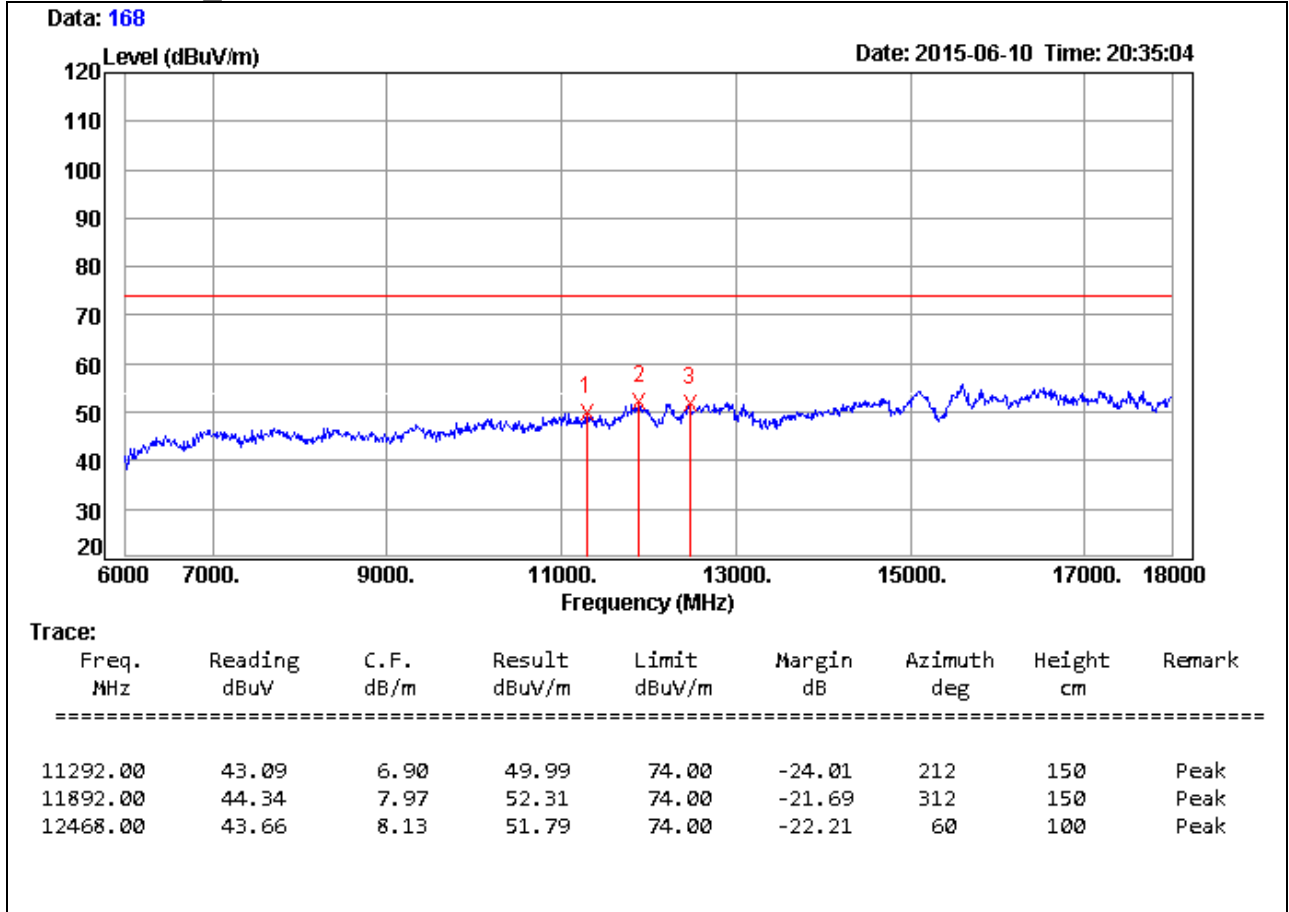

**Remark:**

1. Measuring frequencies from 1 GHz to the 10th harmonic of highest fundamental frequency.
2. Average test would be performed if the peak result were greater than the average limit.
3. Measurements above show only up to 6 maximum emissions noted, or would be lesser, with " N/A " remark, if no specific emissions from the EUT are recorded (ie: margin>20dB from the applicable limit) and considered that's already beyond the background noise floor.
4. Result = Reading + Correction Factor  
Margin = Result – Limit  
Remark Peak = Result(PK) – Limit(PK)  
Remark AVG = Result(AV) – Limit(AV)
5. There is no emission in 18GHz ~ 40GHz.

<b>Product Name</b>	Computer	<b>Test By</b>	Waternil Guan
<b>Test Model</b>	POC127	<b>Test Date</b>	2015/06/09
<b>Test Mode</b>	UNII Band 1/ IEEE 802.11an HT20 TX / CH Middle	<b>Temp. &amp; Humidity</b>	26°C, 52%

966 Chamber\_C at 3Meter / Horizontal

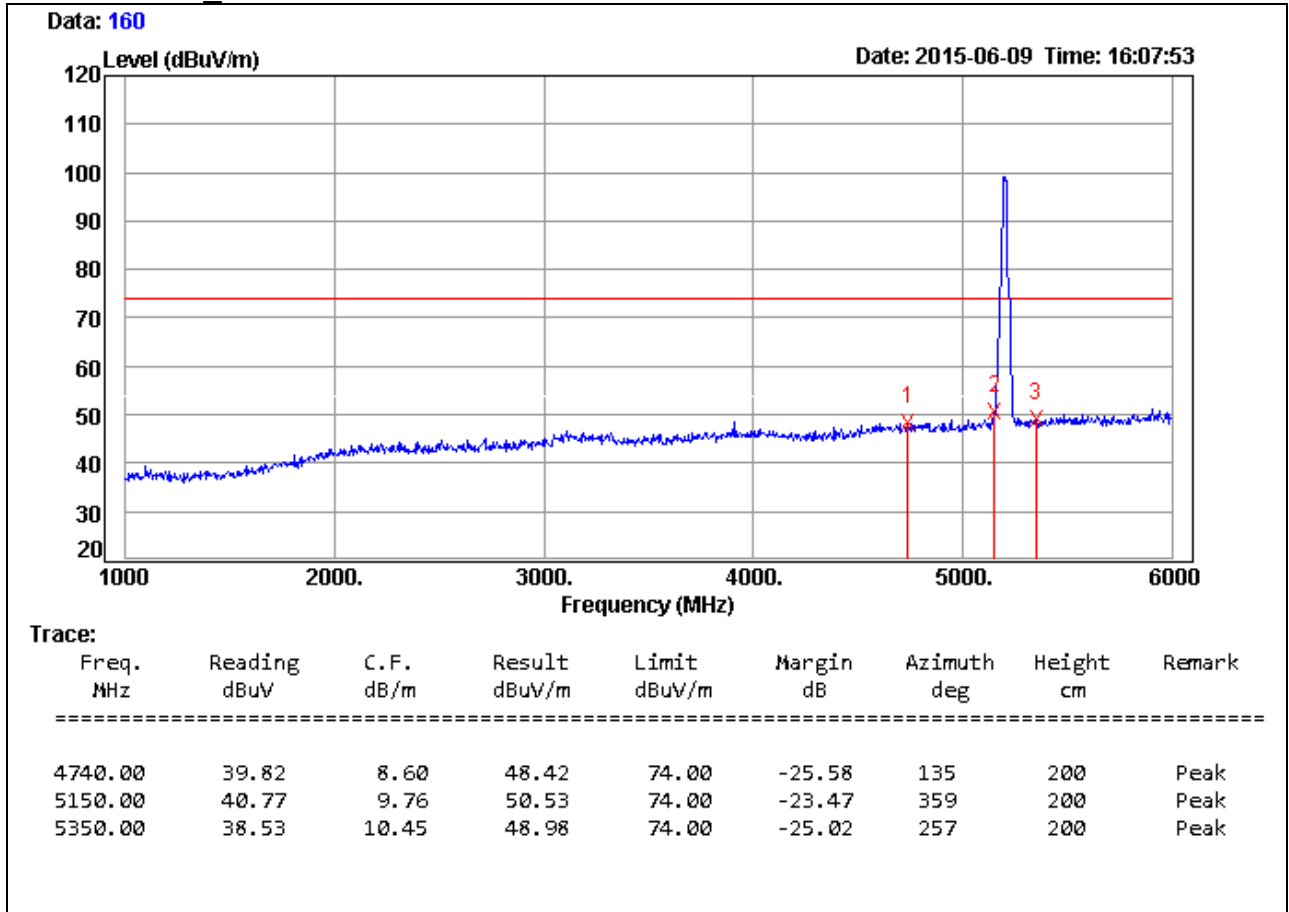

**Remark:**

1. Measuring frequencies from 1 GHz to the 10th harmonic of highest fundamental frequency.
2. Average test would be performed if the peak result were greater than the average limit.
3. Measurements above show only up to 6 maximum emissions noted, or would be lesser, with " N/A " remark, if no specific emissions from the EUT are recorded (ie: margin>20dB from the applicable limit) and considered that's already beyond the background noise floor.
4. Result = Reading + Correction Factor  
Margin = Result - Limit  
Remark Peak = Result(PK) - Limit(PK)  
Remark AVG = Result(AV) - Limit(AV)



<b>Product Name</b>	Computer	<b>Test By</b>	Waternil Guan
<b>Test Model</b>	POC127	<b>Test Date</b>	2015/06/10
<b>Test Mode</b>	UNII Band 1/ IEEE 802.11an HT20 TX / CH Middle	<b>Temp. &amp; Humidity</b>	26°C, 52%

966 Chamber\_C at 3Meter / Horizontal

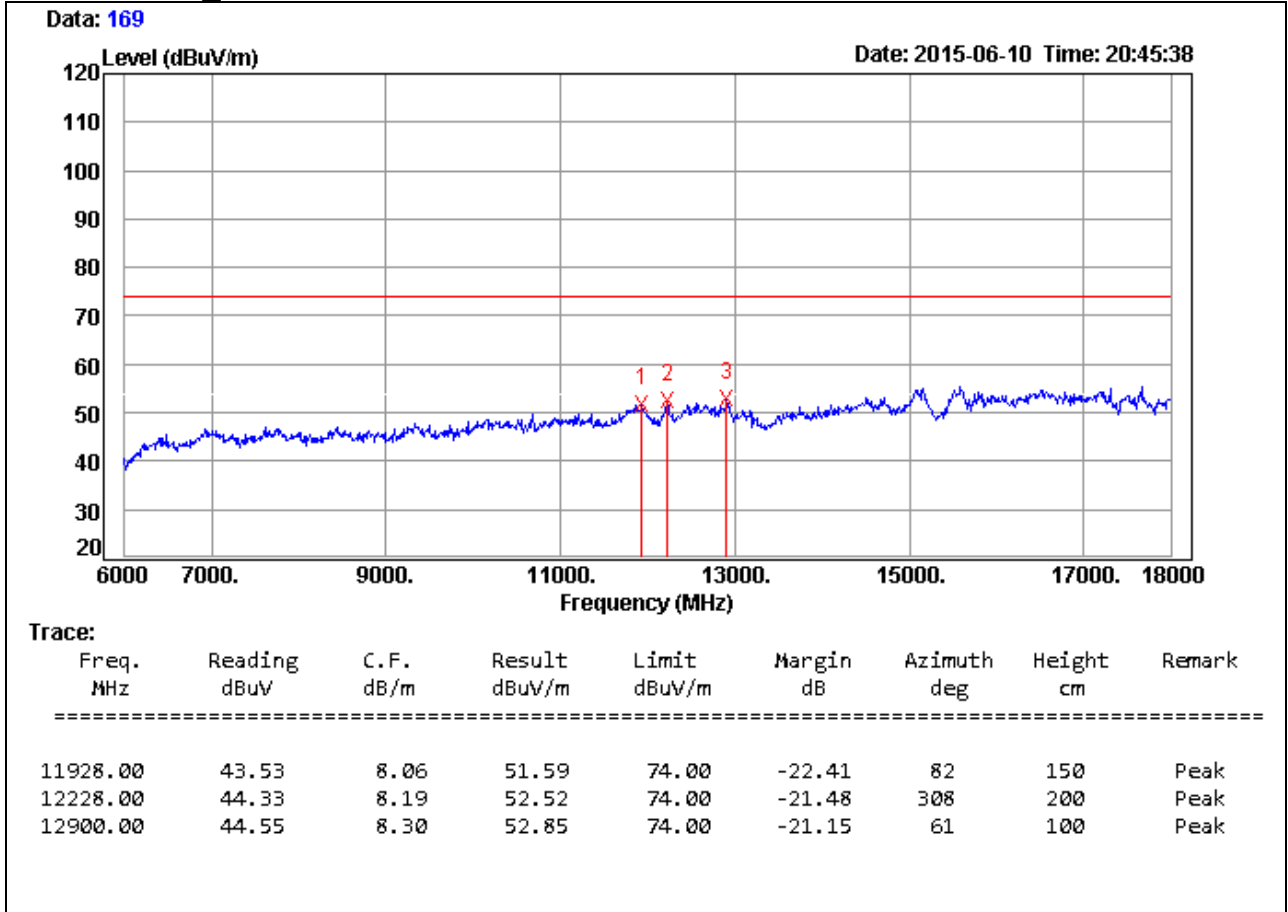

**Remark:**

1. Measuring frequencies from 1 GHz to the 10th harmonic of highest fundamental frequency.
2. Average test would be performed if the peak result were greater than the average limit.
3. Measurements above show only up to 6 maximum emissions noted, or would be lesser, with " N/A " remark, if no specific emissions from the EUT are recorded (ie: margin>20dB from the applicable limit) and considered that's already beyond the background noise floor.
4. Result = Reading + Correction Factor  
Margin = Result - Limit  
Remark Peak = Result(PK) - Limit(PK)  
Remark AVG = Result(AV) - Limit(AV)
5. There is no emission in 18GHz ~ 40GHz.

<b>Product Name</b>	Computer	<b>Test By</b>	Waternil Guan
<b>Test Model</b>	POC127	<b>Test Date</b>	2015/06/09
<b>Test Mode</b>	UNII Band 1/ IEEE 802.11an HT20 TX / CH Middle	<b>Temp. &amp; Humidity</b>	26°C, 52%

966 Chamber\_C at 3Meter / Vertical

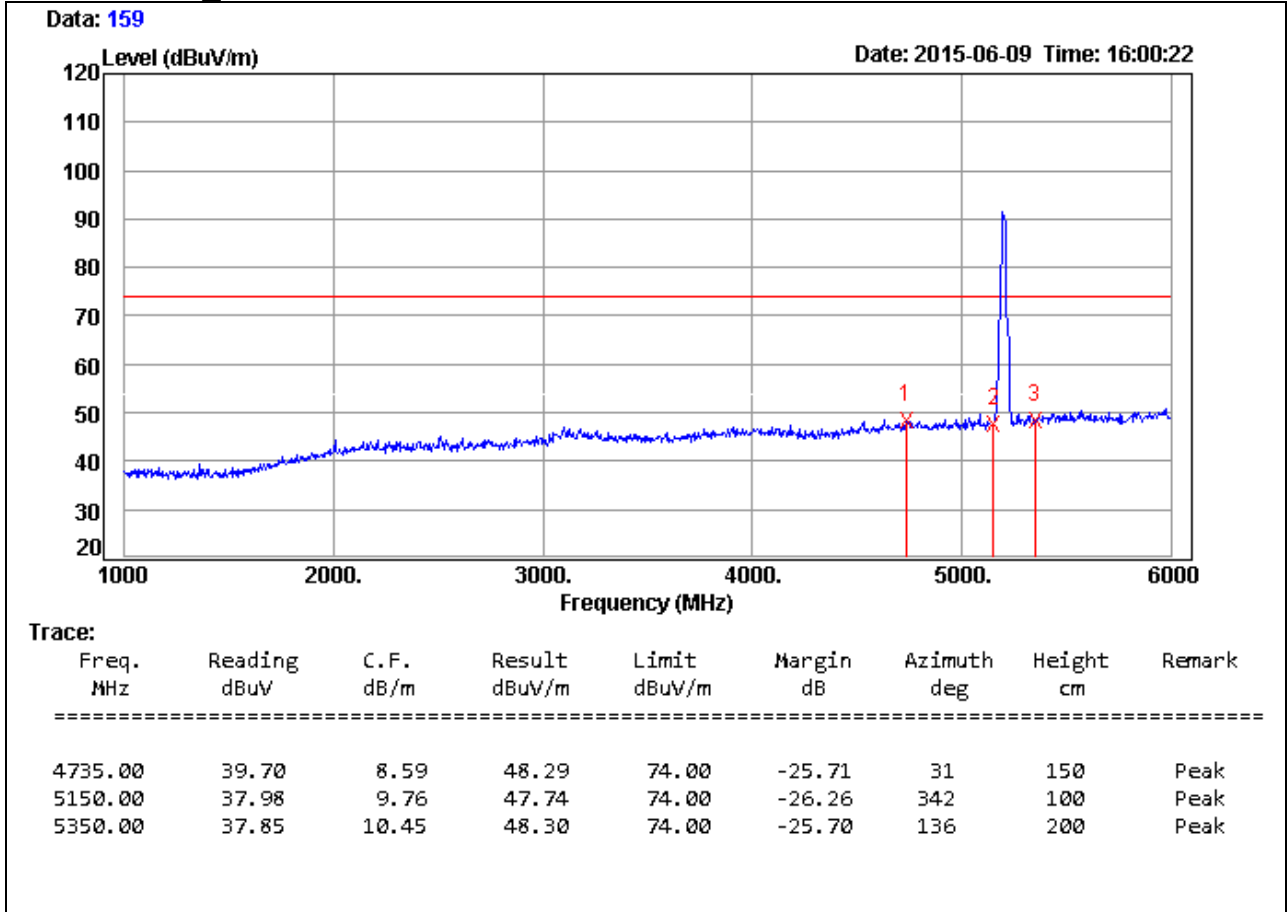

**Remark:**

1. Measuring frequencies from 1 GHz to the 10th harmonic of highest fundamental frequency.
2. Average test would be performed if the peak result were greater than the average limit.
3. Measurements above show only up to 6 maximum emissions noted, or would be lesser, with " N/A " remark, if no specific emissions from the EUT are recorded (ie: margin>20dB from the applicable limit) and considered that's already beyond the background noise floor.
4. Result = Reading + Correction Factor  
 Margin = Result - Limit  
 Remark Peak = Result(PK) - Limit(PK)  
 Remark AVG = Result(AV) - Limit(AV)

<b>Product Name</b>	Computer	<b>Test By</b>	Waternil Guan
<b>Test Model</b>	POC127	<b>Test Date</b>	2015/06/10
<b>Test Mode</b>	UNII Band 1/ IEEE 802.11an HT20 TX / CH Middle	<b>Temp. &amp; Humidity</b>	26°C, 52%

966 Chamber\_C at 3Meter / Vertical

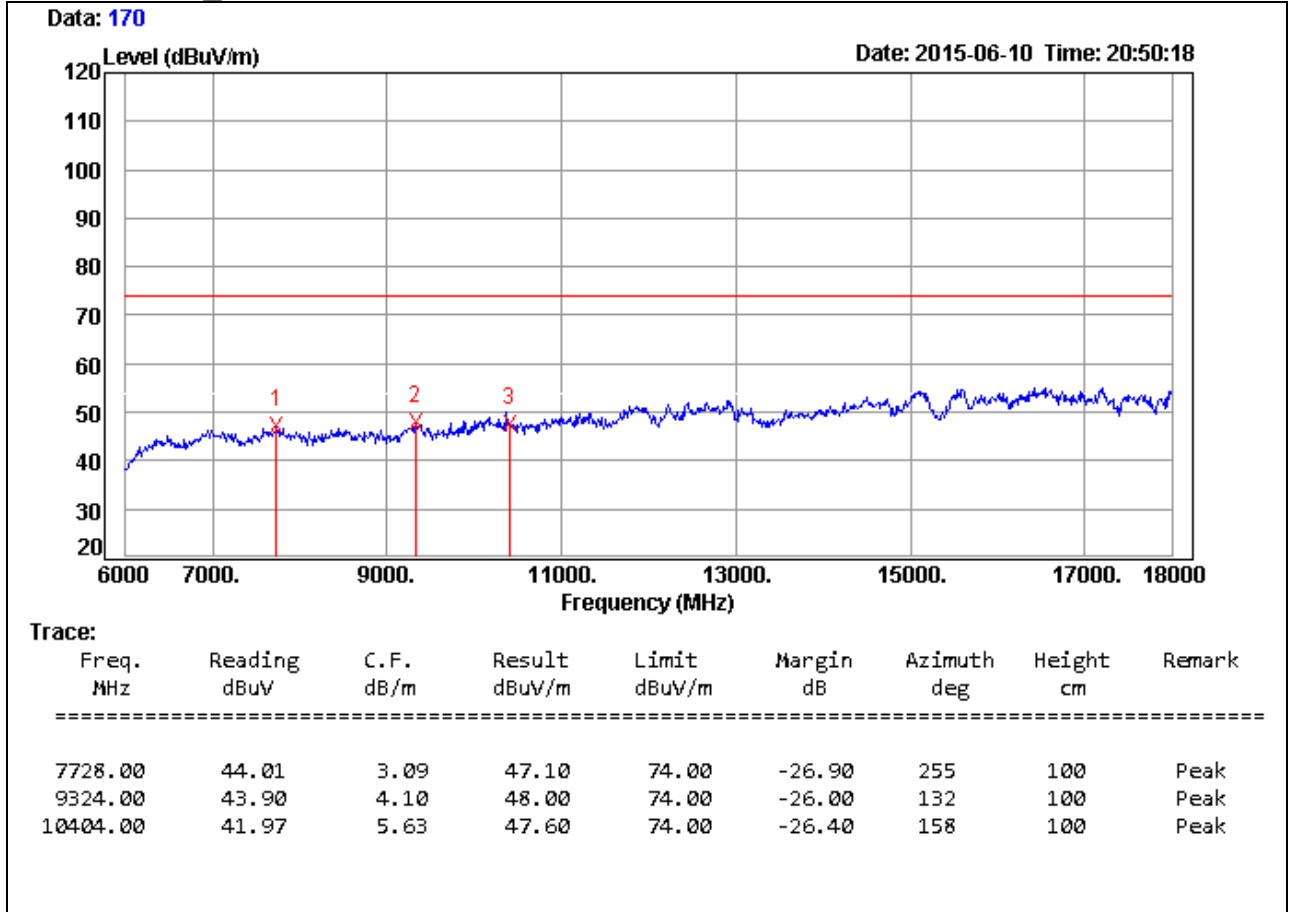

**Remark:**

1. Measuring frequencies from 1 GHz to the 10th harmonic of highest fundamental frequency.
2. Average test would be performed if the peak result were greater than the average limit.
3. Measurements above show only up to 6 maximum emissions noted, or would be lesser, with " N/A " remark, if no specific emissions from the EUT are recorded (ie: margin>20dB from the applicable limit) and considered that's already beyond the background noise floor.
4. Result = Reading + Correction Factor  
Margin = Result – Limit  
Remark Peak = Result(PK) – Limit(PK)  
Remark AVG = Result(AV) – Limit(AV)
5. There is no emission in 18GHz ~ 40GHz.

<b>Product Name</b>	Computer	<b>Test By</b>	Waternil Guan
<b>Test Model</b>	POC127	<b>Test Date</b>	2015/06/09
<b>Test Mode</b>	UNII Band 1/ IEEE 802.11an HT20 TX / CH High	<b>Temp. &amp; Humidity</b>	26°C, 52%

966 Chamber\_C at 3Meter / Horizontal

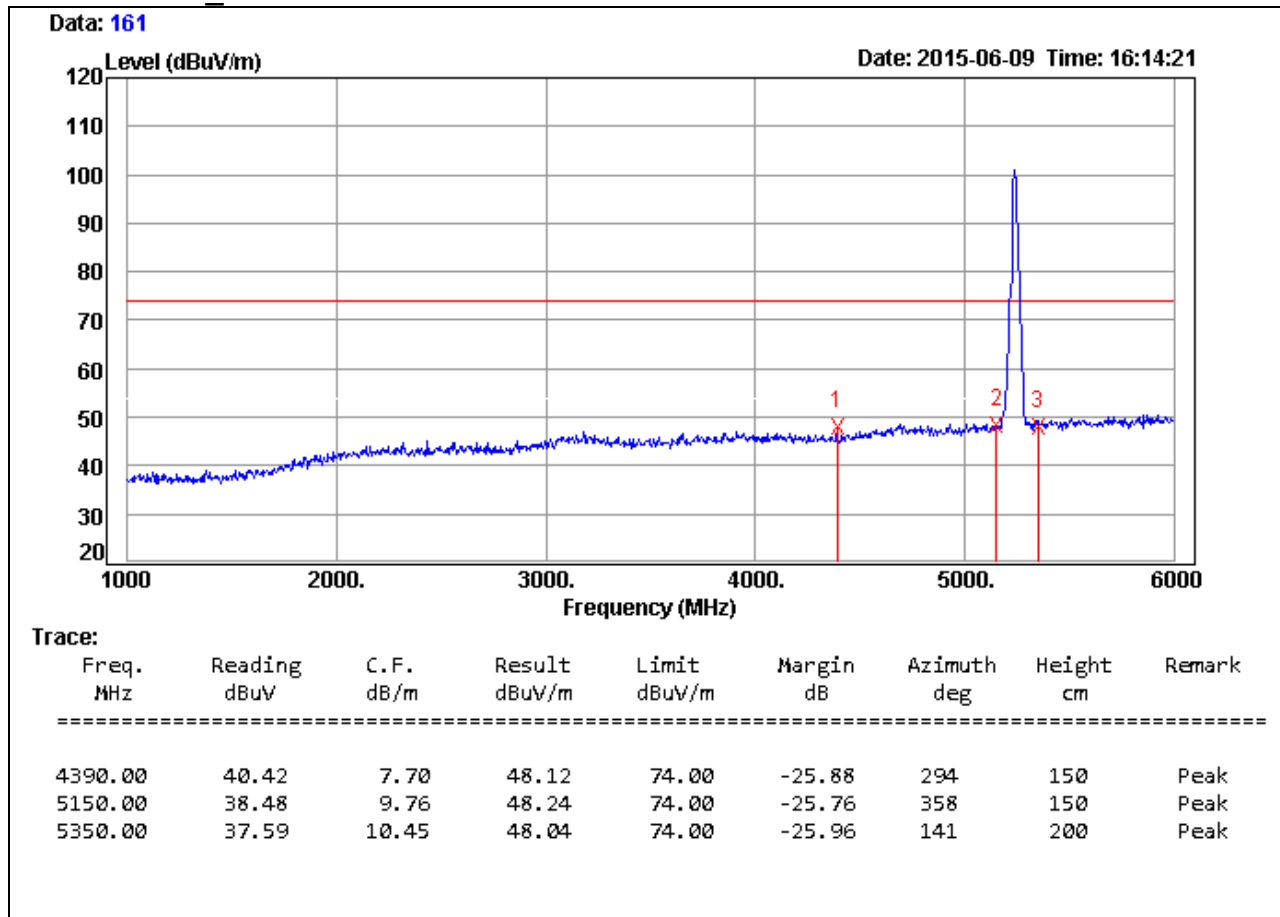

**Remark:**

1. Measuring frequencies from 1 GHz to the 10th harmonic of highest fundamental frequency.
2. Average test would be performed if the peak result were greater than the average limit.
3. Measurements above show only up to 6 maximum emissions noted, or would be lesser, with " N/A " remark, if no specific emissions from the EUT are recorded (ie: margin>20dB from the applicable limit) and considered that's already beyond the background noise floor.
4. Result = Reading + Correction Factor  
 Margin = Result - Limit  
 Remark Peak = Result(PK) - Limit(PK)  
 Remark AVG = Result(AV) - Limit(AV)

<b>Product Name</b>	Computer	<b>Test By</b>	Waternil Guan
<b>Test Model</b>	POC127	<b>Test Date</b>	2015/06/10
<b>Test Mode</b>	UNII Band 1/ IEEE 802.11an HT20 TX / CH High	<b>Temp. &amp; Humidity</b>	26°C, 52%

966 Chamber\_C at 3Meter / Horizontal

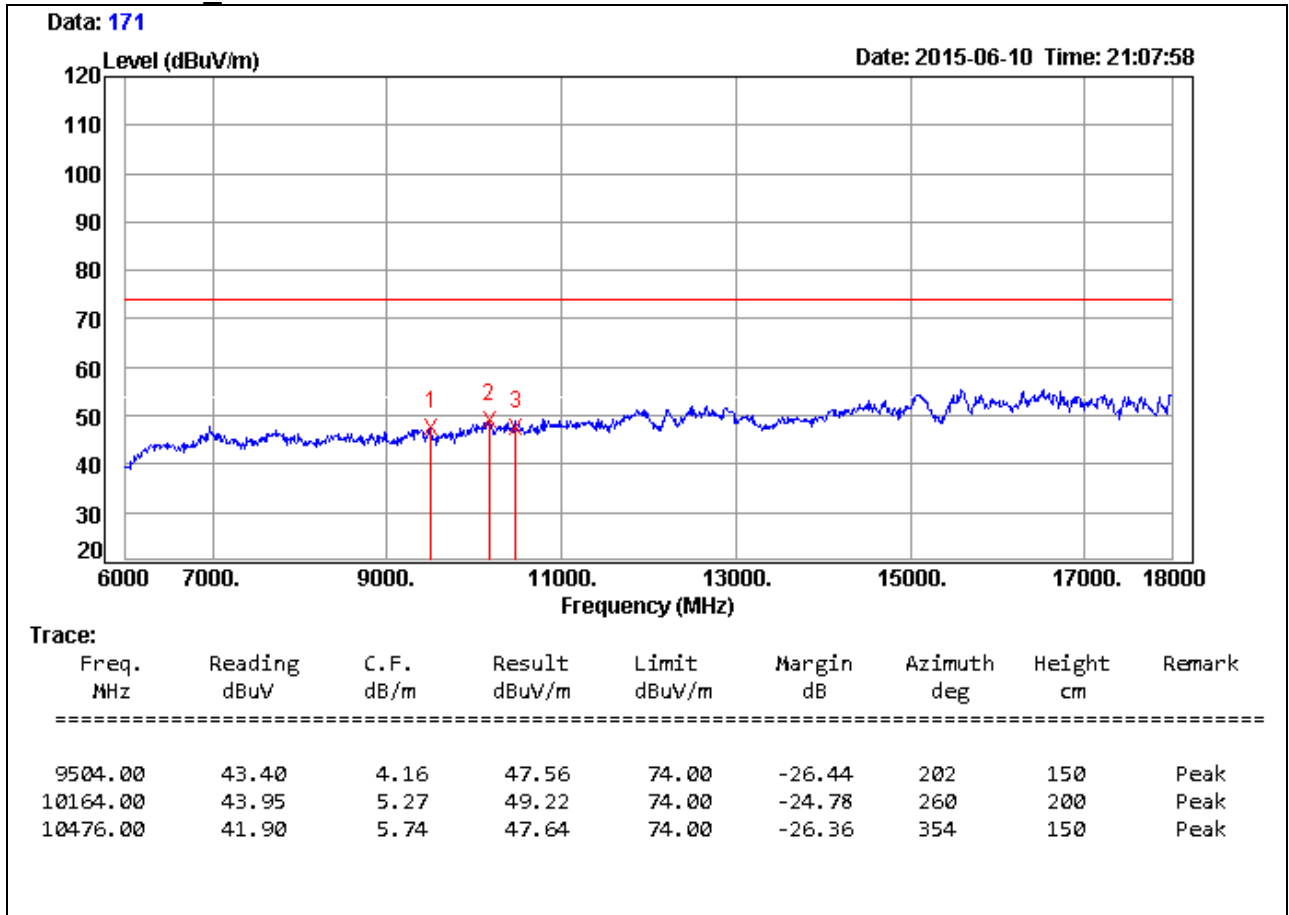

**Remark:**

1. Measuring frequencies from 1 GHz to the 10th harmonic of highest fundamental frequency.
2. Average test would be performed if the peak result were greater than the average limit.
3. Measurements above show only up to 6 maximum emissions noted, or would be lesser, with " N/A " remark, if no specific emissions from the EUT are recorded (ie: margin>20dB from the applicable limit) and considered that's already beyond the background noise floor.
4. Result = Reading + Correction Factor  
Margin = Result - Limit  
Remark Peak = Result(PK) - Limit(PK)  
Remark AVG = Result(AV) - Limit(AV)
5. There is no emission in 18GHz ~ 40GHz.

<b>Product Name</b>	Computer	<b>Test By</b>	Waternil Guan
<b>Test Model</b>	POC127	<b>Test Date</b>	2015/06/09
<b>Test Mode</b>	UNII Band 1/ IEEE 802.11an HT20 TX / CH High	<b>Temp. &amp; Humidity</b>	26°C, 52%

966 Chamber\_C at 3Meter / Vertical

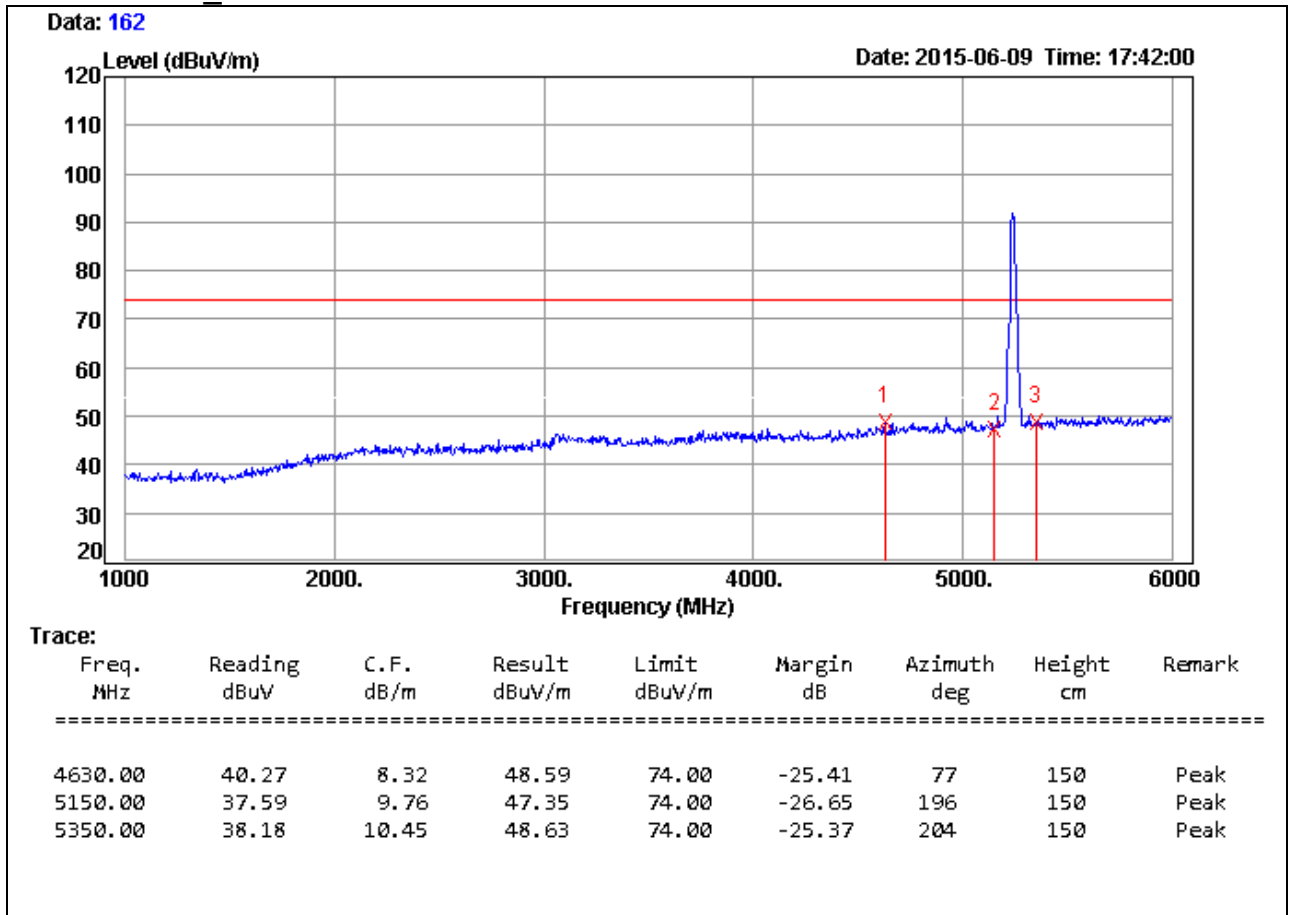

**Remark:**

1. Measuring frequencies from 1 GHz to the 10th harmonic of highest fundamental frequency.
2. Average test would be performed if the peak result were greater than the average limit.
3. Measurements above show only up to 6 maximum emissions noted, or would be lesser, with " N/A " remark, if no specific emissions from the EUT are recorded (ie: margin>20dB from the applicable limit) and considered that's already beyond the background noise floor.
4. Result = Reading + Correction Factor  
 Margin = Result - Limit  
 Remark Peak = Result(PK) - Limit(PK)  
 Remark AVG = Result(AV) - Limit(AV)

<b>Product Name</b>	Computer	<b>Test By</b>	Waternil Guan
<b>Test Model</b>	POC127	<b>Test Date</b>	2015/06/10
<b>Test Mode</b>	UNII Band 1/ IEEE 802.11an HT20 TX / CH High	<b>Temp. &amp; Humidity</b>	26°C, 52%

966 Chamber\_C at 3Meter / Vertical

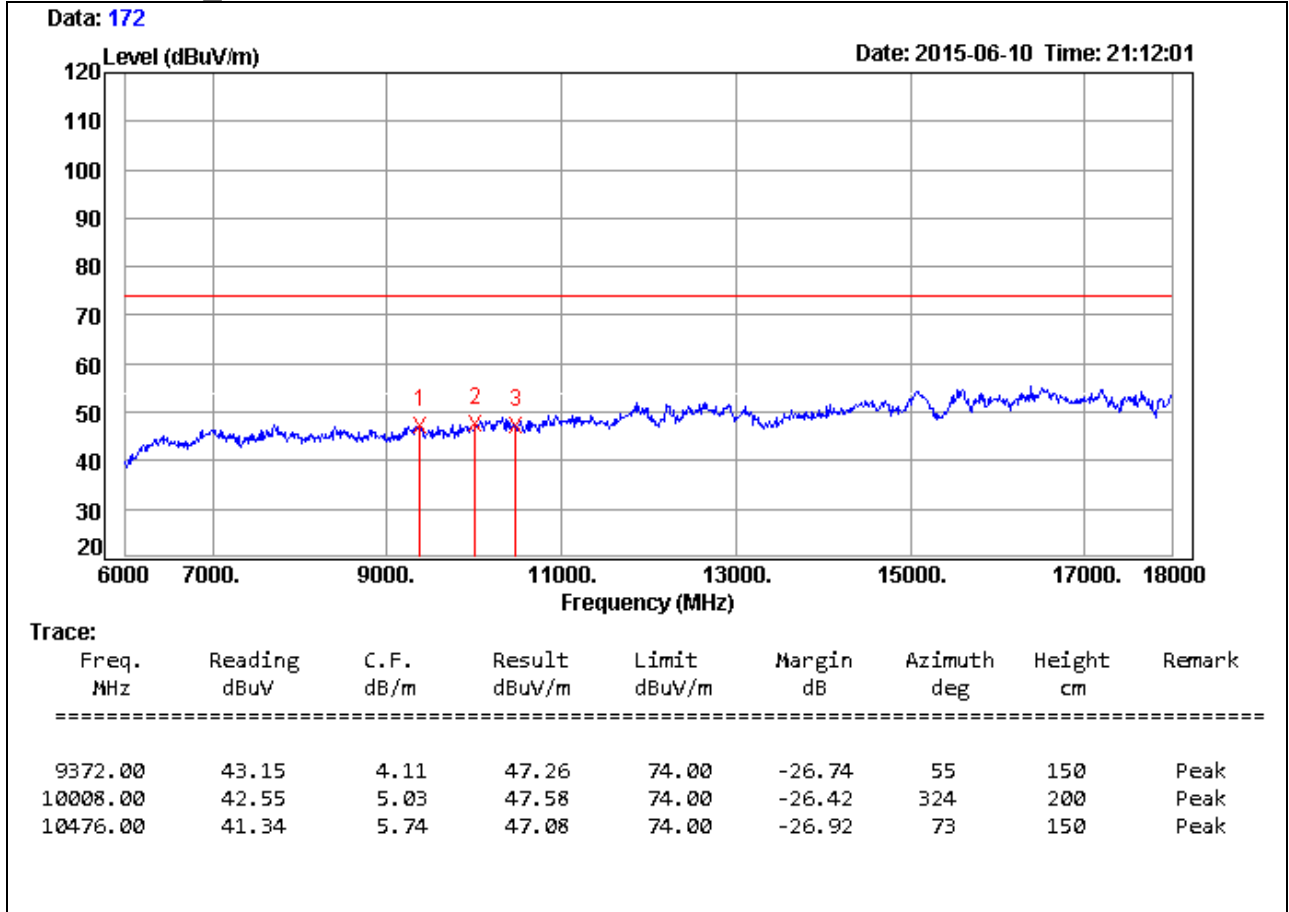

**Remark:**

1. Measuring frequencies from 1 GHz to the 10th harmonic of highest fundamental frequency.
2. Average test would be performed if the peak result were greater than the average limit.
3. Measurements above show only up to 6 maximum emissions noted, or would be lesser, with " N/A " remark, if no specific emissions from the EUT are recorded (ie: margin>20dB from the applicable limit) and considered that's already beyond the background noise floor.
4. Result = Reading + Correction Factor  
 Margin = Result - Limit  
 Remark Peak = Result(PK) - Limit(PK)  
 Remark AVG = Result(AV) - Limit(AV)
5. There is no emission in 18GHz ~ 40GHz.

<b>Product Name</b>	Computer	<b>Test By</b>	Waternil Guan
<b>Test Model</b>	POC127	<b>Test Date</b>	2015/06/22
<b>Test Mode</b>	UNII Band 1/ IEEE 802.11an HT40 TX / CH Low	<b>Temp. &amp; Humidity</b>	26°C, 52%

966 Chamber\_C at 3Meter / Horizontal

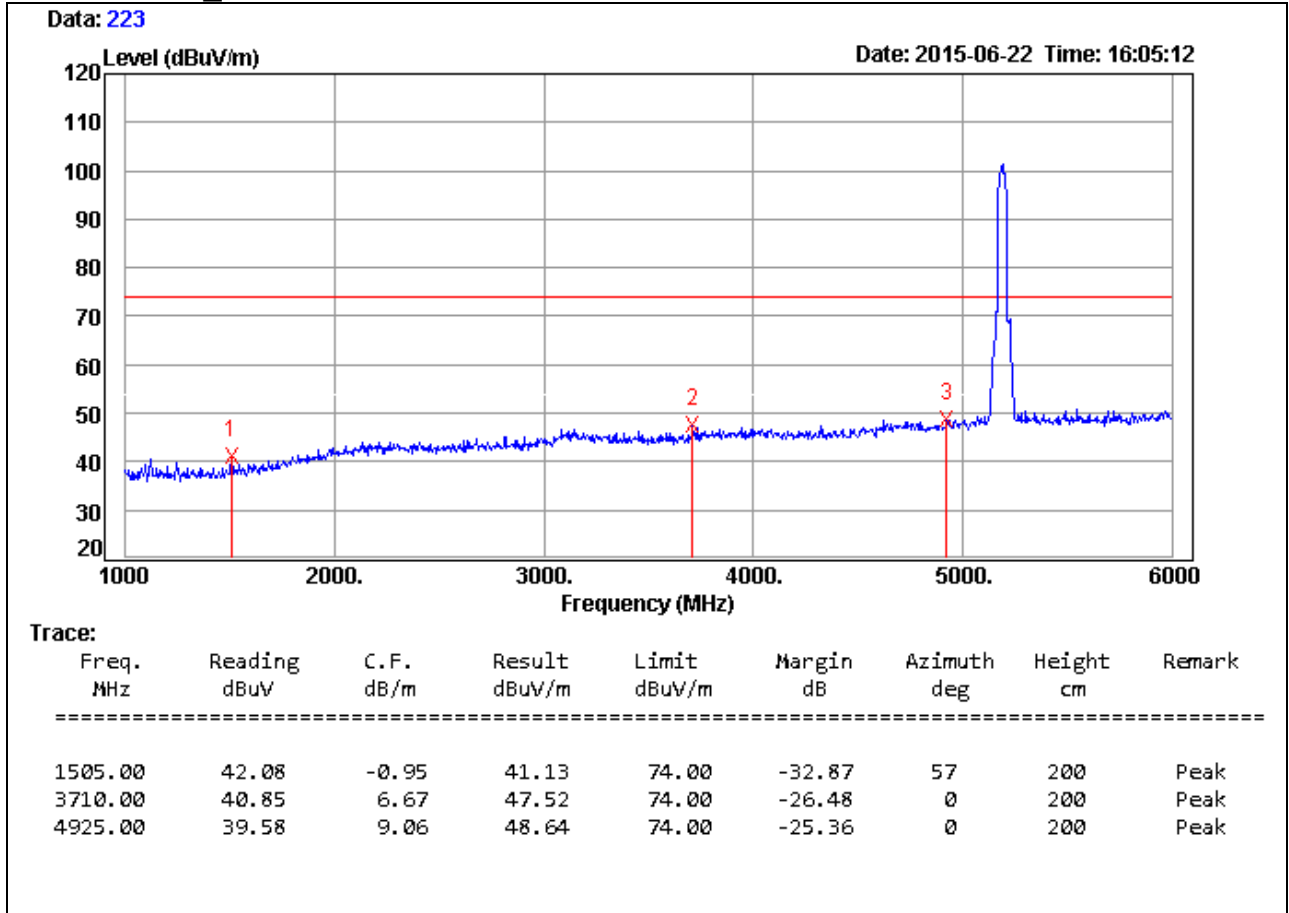

**Remark:**

1. Measuring frequencies from 1 GHz to the 10th harmonic of highest fundamental frequency.
2. Average test would be performed if the peak result were greater than the average limit.
3. Measurements above show only up to 6 maximum emissions noted, or would be lesser, with " N/A " remark, if no specific emissions from the EUT are recorded (ie: margin>20dB from the applicable limit) and considered that's already beyond the background noise floor.
4. Result = Reading + Correction Factor  
Margin = Result - Limit  
Remark Peak = Result(PK) - Limit(PK)  
Remark AVG = Result(AV) - Limit(AV)



<b>Product Name</b>	Computer	<b>Test By</b>	Waternil Guan
<b>Test Model</b>	POC127	<b>Test Date</b>	2015/06/18
<b>Test Mode</b>	UNII Band 1/ IEEE 802.11an HT40 TX / CH Low	<b>Temp. &amp; Humidity</b>	26°C, 52%

966 Chamber\_C at 3Meter / Horizontal

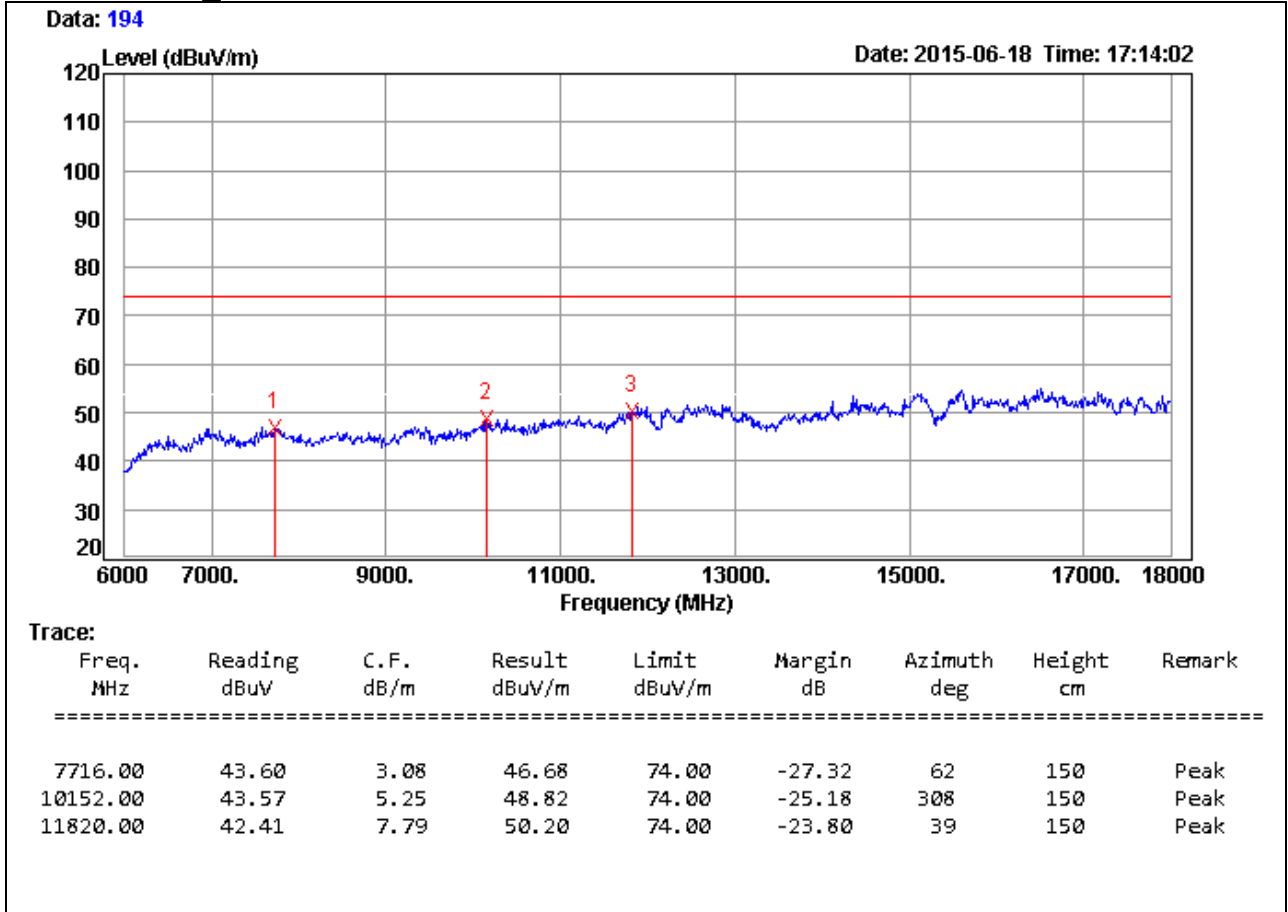

**Remark:**

1. Measuring frequencies from 1 GHz to the 10th harmonic of highest fundamental frequency.
2. Average test would be performed if the peak result were greater than the average limit.
3. Measurements above show only up to 6 maximum emissions noted, or would be lesser, with " N/A " remark, if no specific emissions from the EUT are recorded (ie: margin>20dB from the applicable limit) and considered that's already beyond the background noise floor.
4. Result = Reading + Correction Factor  
Margin = Result - Limit  
Remark Peak = Result(PK) - Limit(PK)  
Remark AVG = Result(AV) - Limit(AV)
5. There is no emission in 18GHz ~ 40GHz.

<b>Product Name</b>	Computer	<b>Test By</b>	Waternil Guan
<b>Test Model</b>	POC127	<b>Test Date</b>	2014/06/22
<b>Test Mode</b>	UNII Band 1/ IEEE 802.11an HT40 TX / CH Low	<b>Temp. &amp; Humidity</b>	26°C, 52%

966 Chamber\_C at 3Meter / Vertical

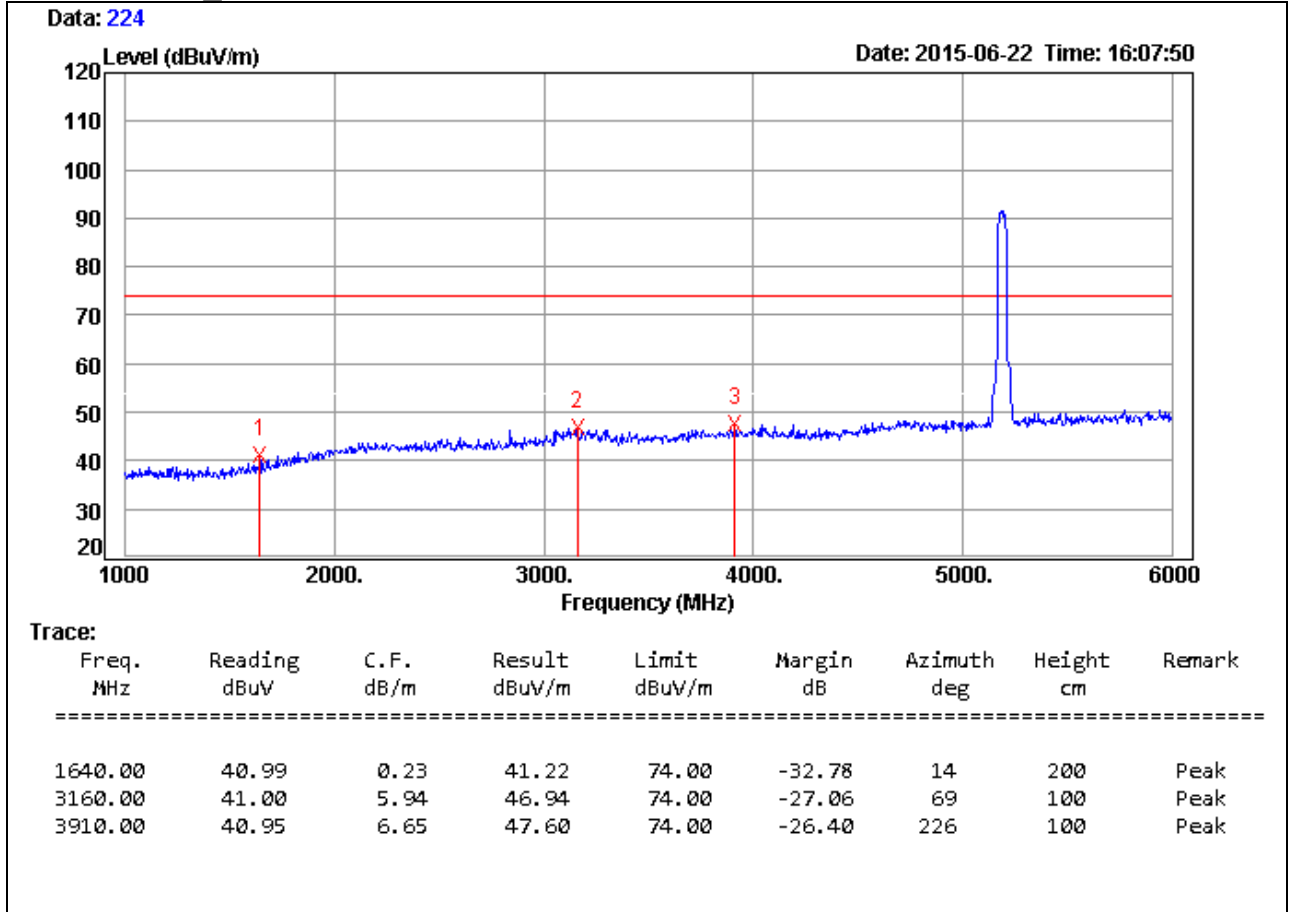

**Remark:**

1. Measuring frequencies from 1 GHz to the 10th harmonic of highest fundamental frequency.
2. Average test would be performed if the peak result were greater than the average limit.
3. Measurements above show only up to 6 maximum emissions noted, or would be lesser, with " N/A " remark, if no specific emissions from the EUT are recorded (ie: margin>20dB from the applicable limit) and considered that's already beyond the background noise floor.
4. Result = Reading + Correction Factor  
 Margin = Result - Limit  
 Remark Peak = Result(PK) - Limit(PK)  
 Remark AVG = Result(AV) - Limit(AV)

<b>Product Name</b>	Computer	<b>Test By</b>	Waternil Guan
<b>Test Model</b>	POC127	<b>Test Date</b>	2015/06/18
<b>Test Mode</b>	UNII Band 1/ IEEE 802.11an HT40 TX / CH Low	<b>Temp. &amp; Humidity</b>	26°C, 52%

966 Chamber\_C at 3Meter / Vertical

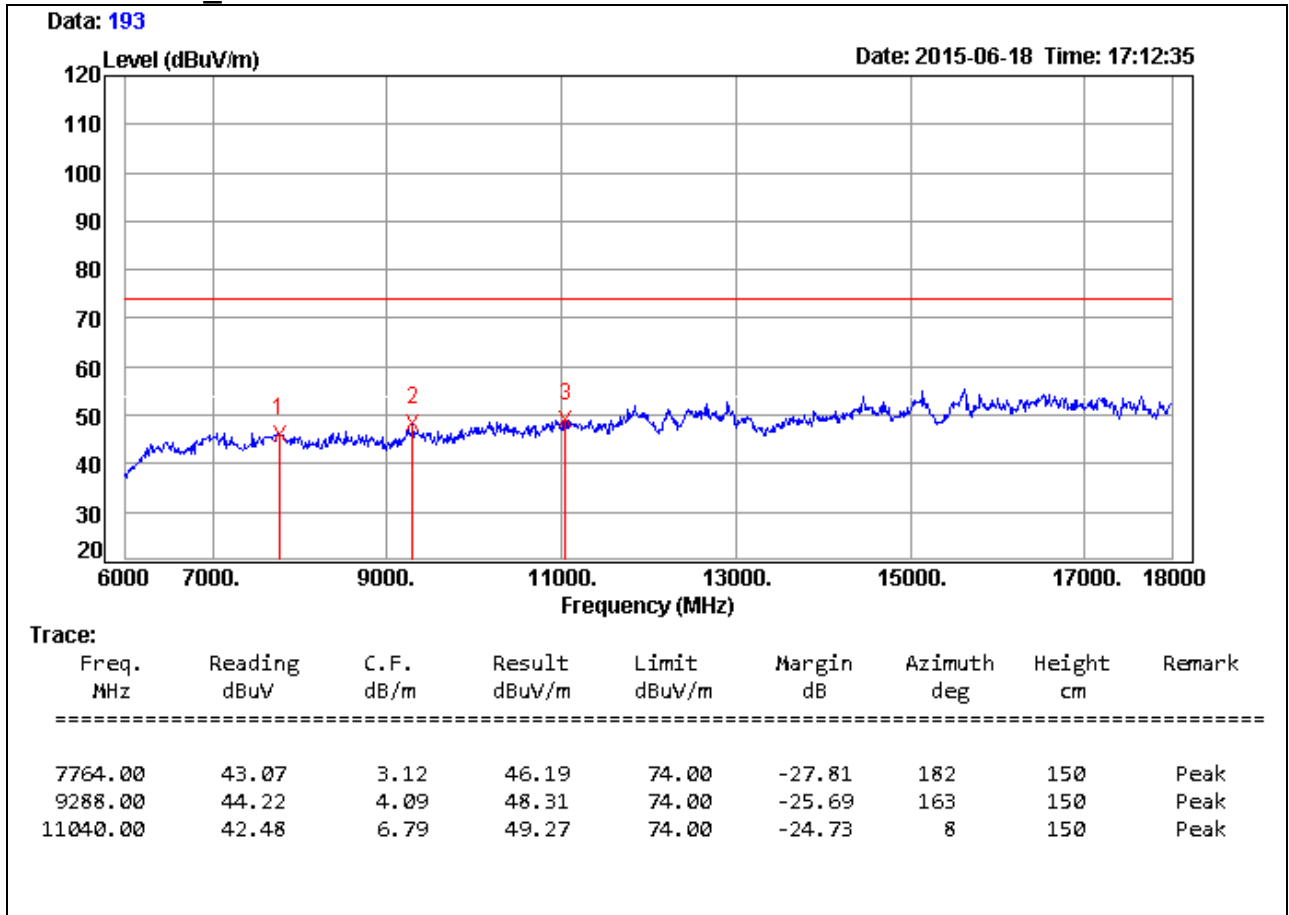

**Remark:**

1. Measuring frequencies from 1 GHz to the 10th harmonic of highest fundamental frequency.
2. Average test would be performed if the peak result were greater than the average limit.
3. Measurements above show only up to 6 maximum emissions noted, or would be lesser, with " N/A " remark, if no specific emissions from the EUT are recorded (ie: margin>20dB from the applicable limit) and considered that's already beyond the background noise floor.
4. Result = Reading + Correction Factor  
Margin = Result - Limit  
Remark Peak = Result(PK) - Limit(PK)  
Remark AVG = Result(AV) - Limit(AV)
5. There is no emission in 18GHz ~ 40GHz.

<b>Product Name</b>	Computer	<b>Test By</b>	Waternil Guan
<b>Test Model</b>	POC127	<b>Test Date</b>	2015/06/22
<b>Test Mode</b>	UNII Band 1/ IEEE 802.11an HT40 TX / CH High	<b>Temp. &amp; Humidity</b>	26°C, 52%

966 Chamber\_C at 3Meter / Horizontal

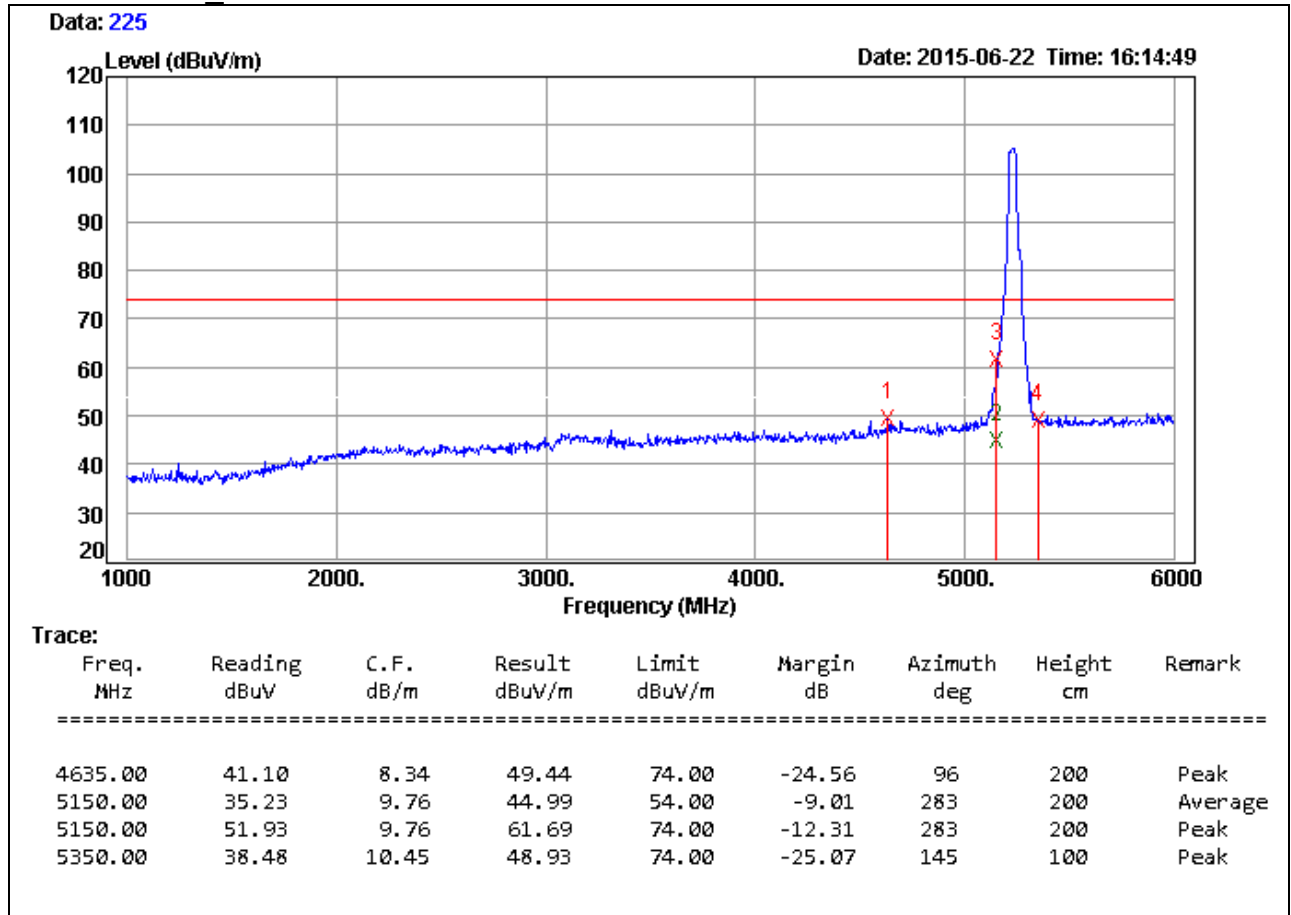

**Remark:**

1. Measuring frequencies from 1 GHz to the 10th harmonic of highest fundamental frequency.
2. Average test would be performed if the peak result were greater than the average limit.
3. Measurements above show only up to 6 maximum emissions noted, or would be lesser, with " N/A " remark, if no specific emissions from the EUT are recorded (ie: margin>20dB from the applicable limit) and considered that's already beyond the background noise floor.
4. Result = Reading + Correction Factor  
 Margin = Result - Limit  
 Remark Peak = Result(PK) - Limit(PK)  
 Remark AVG = Result(AV) - Limit(AV)

<b>Product Name</b>	Computer	<b>Test By</b>	Waternil Guan
<b>Test Model</b>	POC127	<b>Test Date</b>	2015/06/18
<b>Test Mode</b>	UNII Band 1/ IEEE 802.11an HT40 TX / CH High	<b>Temp. &amp; Humidity</b>	26°C, 52%

966 Chamber\_C at 3Meter / Horizontal

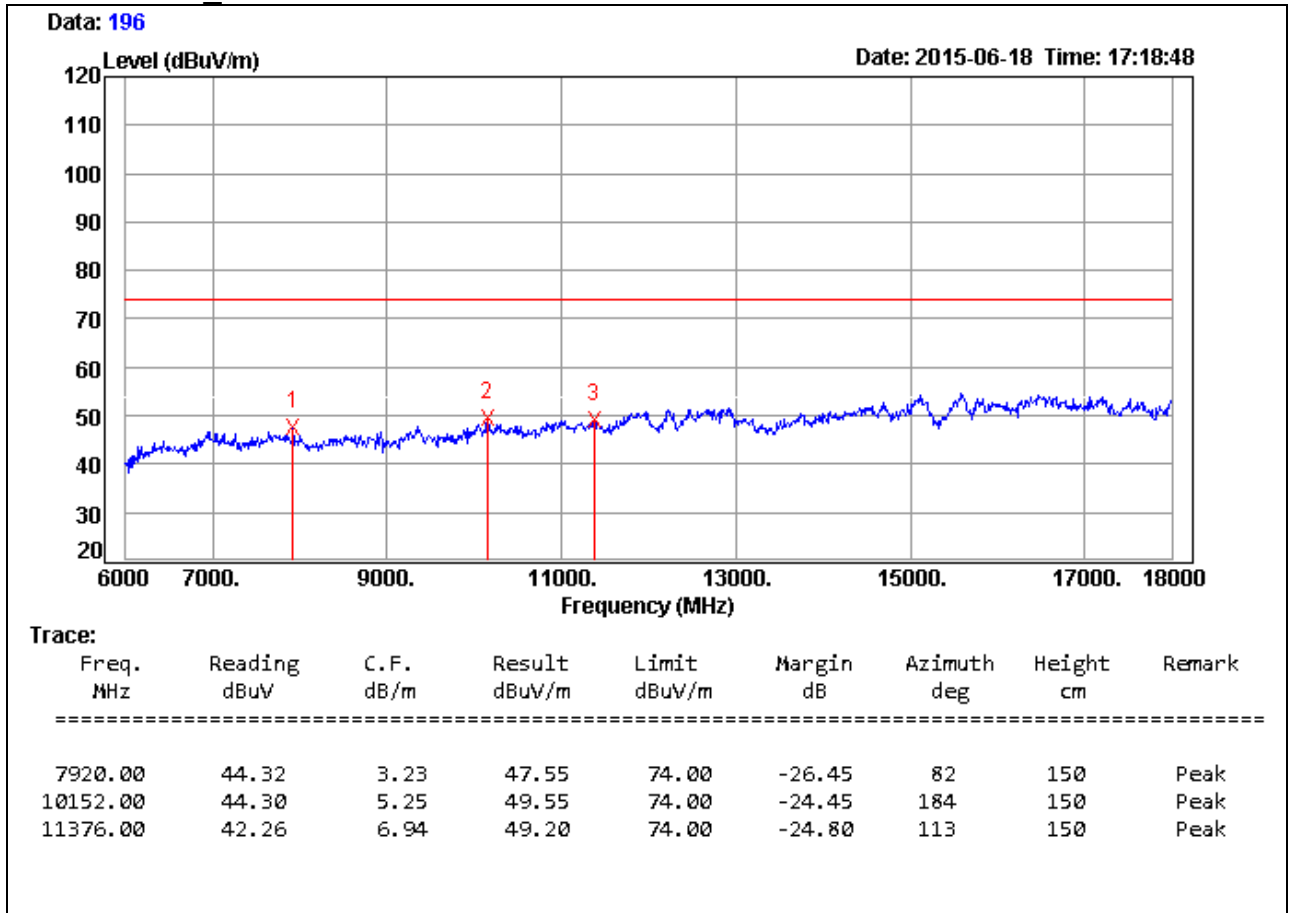

**Remark:**

1. Measuring frequencies from 1 GHz to the 10th harmonic of highest fundamental frequency.
2. Average test would be performed if the peak result were greater than the average limit.
3. Measurements above show only up to 6 maximum emissions noted, or would be lesser, with " N/A " remark, if no specific emissions from the EUT are recorded (ie: margin>20dB from the applicable limit) and considered that's already beyond the background noise floor.
4. Result = Reading + Correction Factor  
Margin = Result - Limit  
Remark Peak = Result(PK) - Limit(PK)  
Remark AVG = Result(AV) - Limit(AV)
5. There is no emission in 18GHz ~ 40GHz.

<b>Product Name</b>	Computer	<b>Test By</b>	Waternil Guan
<b>Test Model</b>	POC127	<b>Test Date</b>	2015/06/22
<b>Test Mode</b>	UNII Band 1/ IEEE 802.11an HT40 TX / CH High	<b>Temp. &amp; Humidity</b>	26°C, 52%

966 Chamber\_C at 3Meter / Vertical

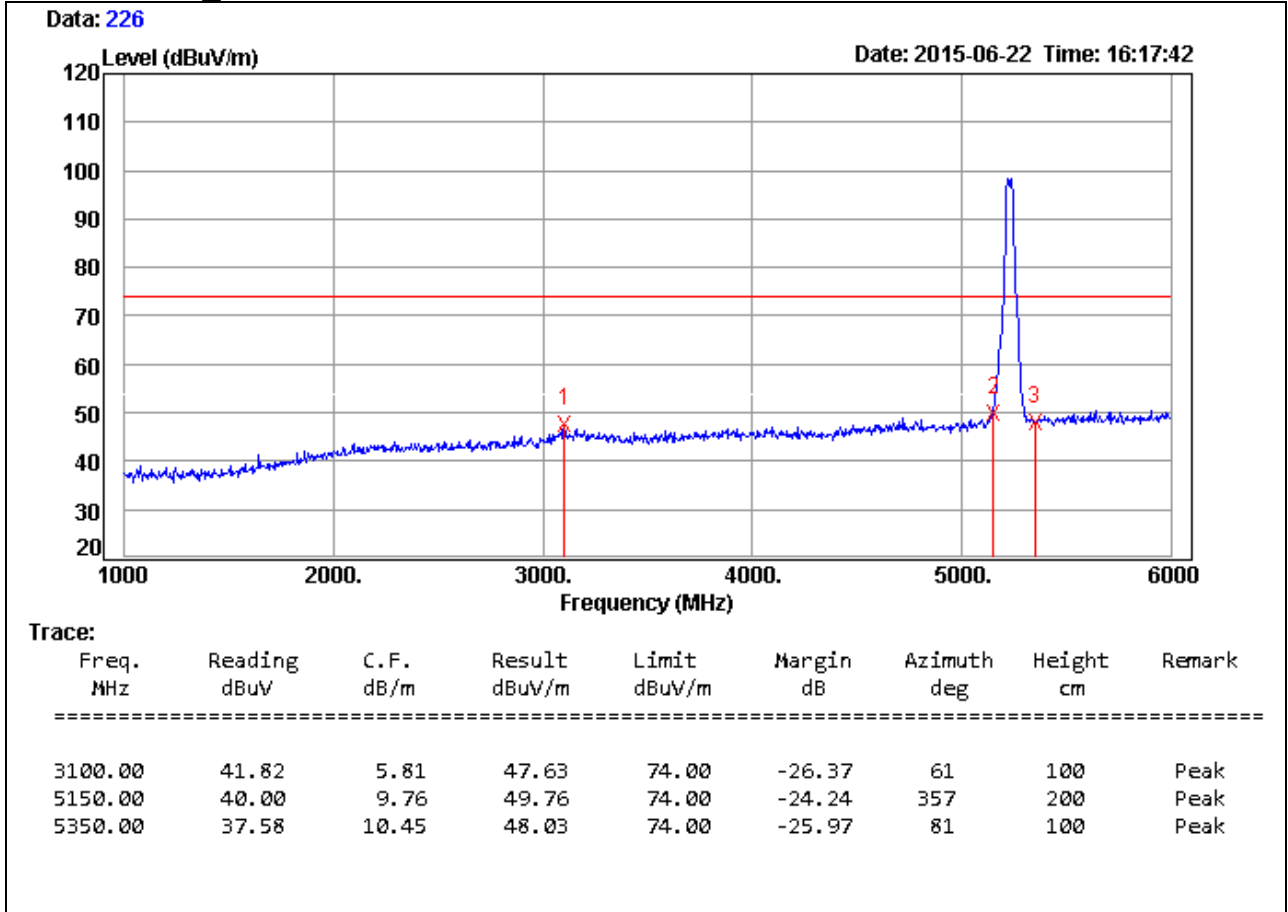

**Remark:**

1. Measuring frequencies from 1 GHz to the 10th harmonic of highest fundamental frequency.
2. Average test would be performed if the peak result were greater than the average limit.
3. Measurements above show only up to 6 maximum emissions noted, or would be lesser, with " N/A " remark, if no specific emissions from the EUT are recorded (ie: margin>20dB from the applicable limit) and considered that's already beyond the background noise floor.
4. Result = Reading + Correction Factor  
 Margin = Result - Limit  
 Remark Peak = Result(PK) - Limit(PK)  
 Remark AVG = Result(AV) - Limit(AV)

<b>Product Name</b>	Computer	<b>Test By</b>	Watnail Guan
<b>Test Model</b>	POC127	<b>Test Date</b>	2015/06/18
<b>Test Mode</b>	UNII Band 1/ IEEE 802.11an HT40 TX / CH High	<b>Temp. &amp; Humidity</b>	26°C, 52%

966 Chamber\_C at 3Meter / Vertical

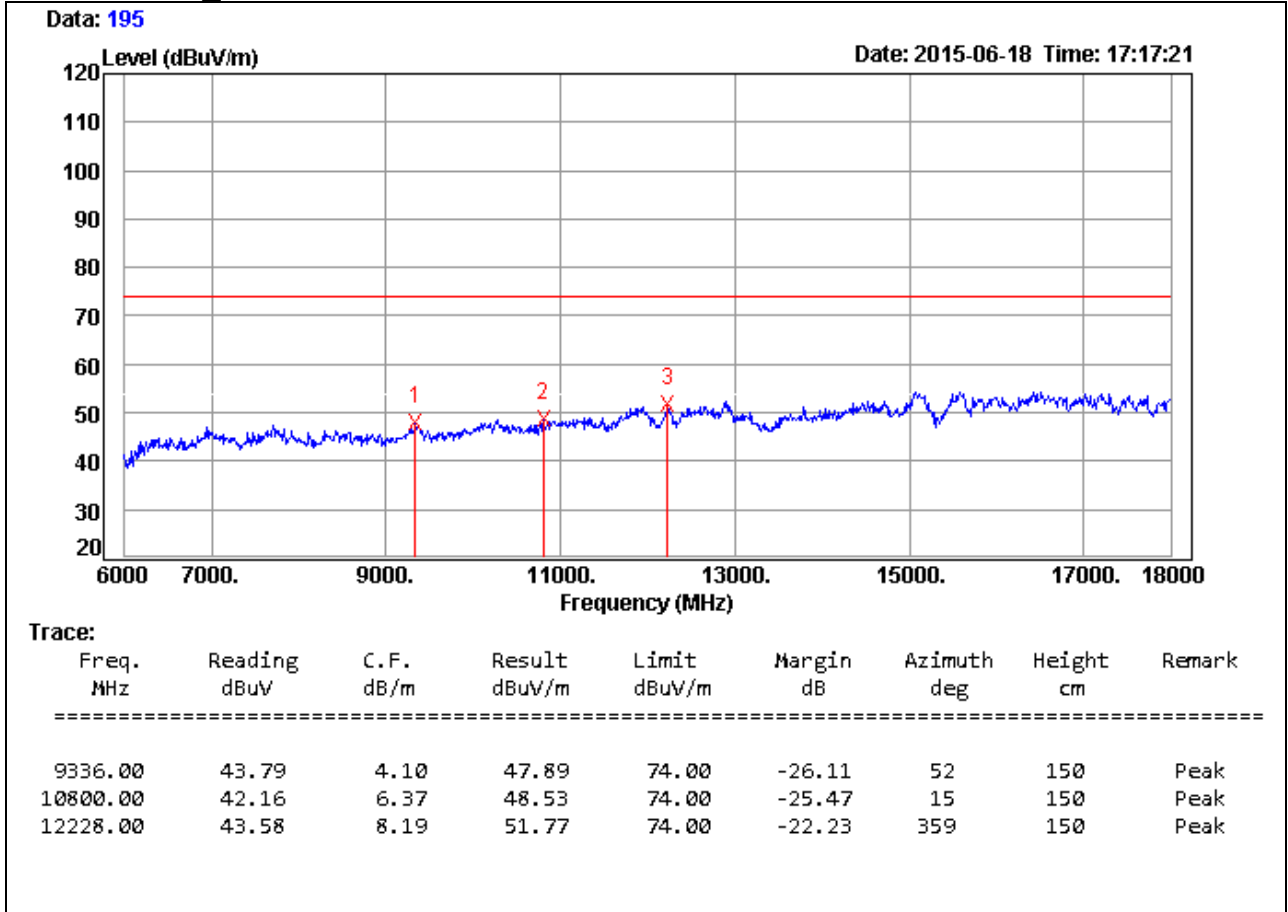

**Remark:**

1. Measuring frequencies from 1 GHz to the 10th harmonic of highest fundamental frequency.
2. Average test would be performed if the peak result were greater than the average limit.
3. Measurements above show only up to 6 maximum emissions noted, or would be lesser, with " N/A " remark, if no specific emissions from the EUT are recorded (ie: margin>20dB from the applicable limit) and considered that's already beyond the background noise floor.
4. Result = Reading + Correction Factor  
Margin = Result - Limit  
Remark Peak = Result(PK) - Limit(PK)  
Remark AVG = Result(AV) - Limit(AV)
5. There is no emission in 18GHz ~ 40GHz.

<b>Product Name</b>	Computer	<b>Test By</b>	Waternil Guan
<b>Test Model</b>	POC127	<b>Test Date</b>	2015/06/05
<b>Test Mode</b>	UNII Band 2A/ IEEE 802.11a TX / CH Low	<b>Temp. &amp; Humidity</b>	26°C, 52%

966 Chamber\_C at 3Meter / Horizontal

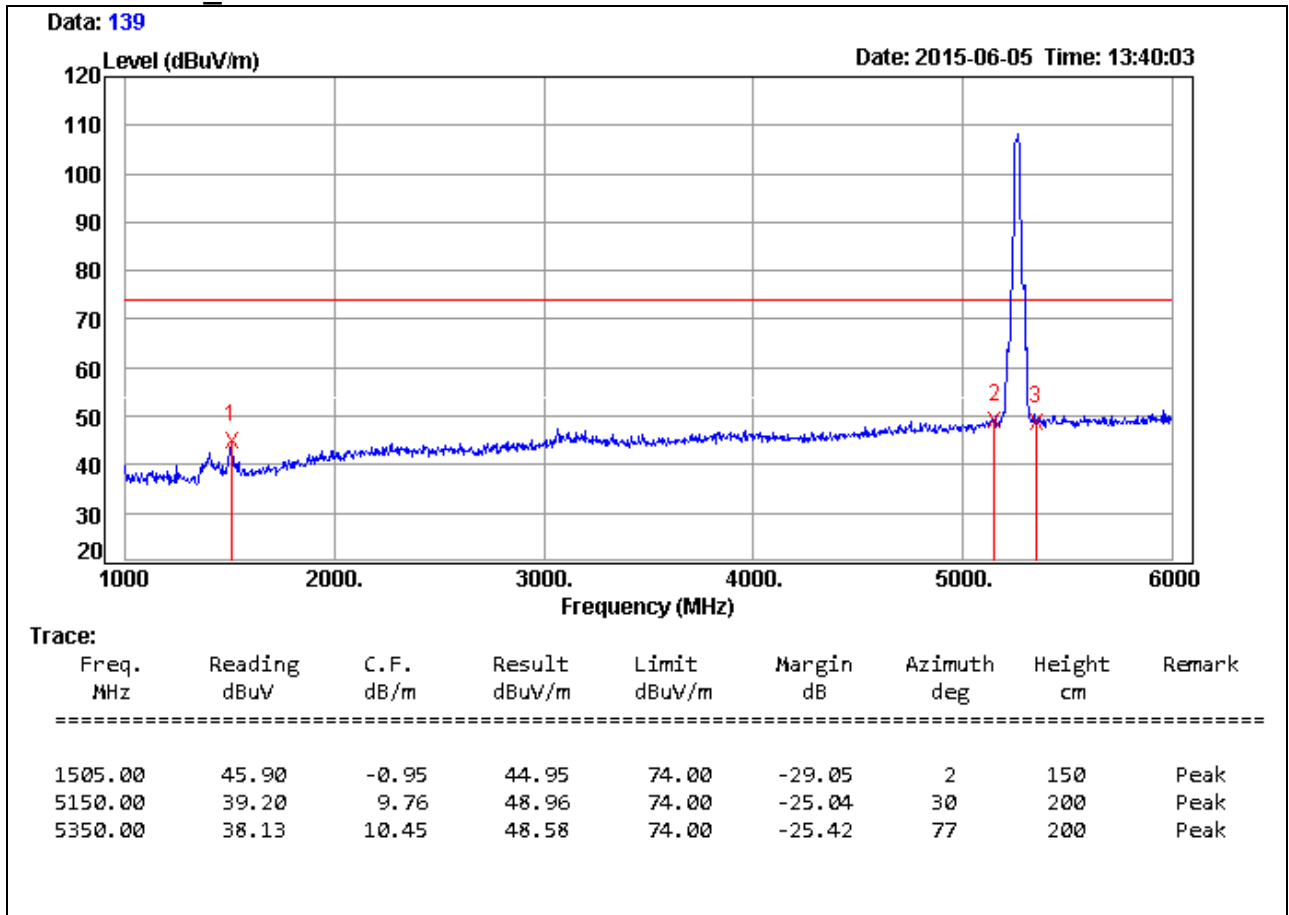

**Remark:**

1. Measuring frequencies from 1 GHz to the 10th harmonic of highest fundamental frequency.
2. Average test would be performed if the peak result were greater than the average limit.
3. Measurements above show only up to 6 maximum emissions noted, or would be lesser, with " N/A " remark, if no specific emissions from the EUT are recorded (ie: margin>20dB from the applicable limit) and considered that's already beyond the background noise floor.
4. Result = Reading + Correction Factor  
 Margin = Result - Limit  
 Remark Peak = Result(PK) - Limit(PK)  
 Remark AVG = Result(AV) - Limit(AV)



<b>Product Name</b>	Computer	<b>Test By</b>	Waternil Guan
<b>Test Model</b>	POC127	<b>Test Date</b>	2015/06/04
<b>Test Mode</b>	UNII Band 2A/ IEEE 802.11a TX / CH Low	<b>Temp. &amp; Humidity</b>	26°C, 52%

966 Chamber\_C at 3Meter / Horizontal

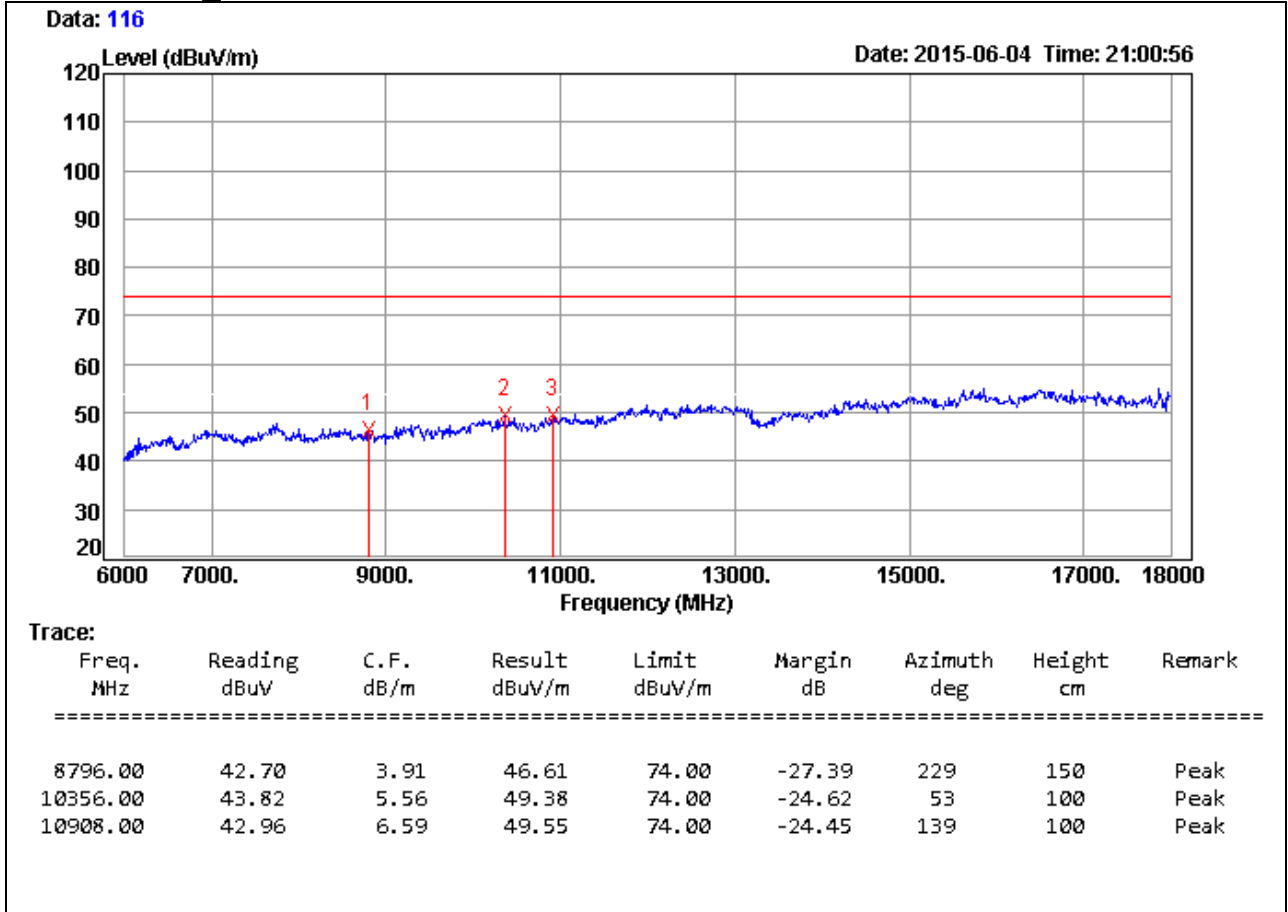

**Remark:**

1. Measuring frequencies from 1 GHz to the 10th harmonic of highest fundamental frequency.
2. Average test would be performed if the peak result were greater than the average limit.
3. Measurements above show only up to 6 maximum emissions noted, or would be lesser, with " N/A " remark, if no specific emissions from the EUT are recorded (ie: margin>20dB from the applicable limit) and considered that's already beyond the background noise floor.
4. Result = Reading + Correction Factor  
 Margin = Result - Limit  
 Remark Peak = Result(PK) - Limit(PK)  
 Remark AVG = Result(AV) - Limit(AV)
5. There is no emission in 18GHz ~ 40GHz.

<b>Product Name</b>	Computer	<b>Test By</b>	Waternil Guan
<b>Test Model</b>	POC127	<b>Test Date</b>	2015/06/05
<b>Test Mode</b>	UNII Band 2A/ IEEE 802.11a TX / CH Low	<b>Temp. &amp; Humidity</b>	26°C, 52%

966 Chamber\_C at 3Meter / Vertical

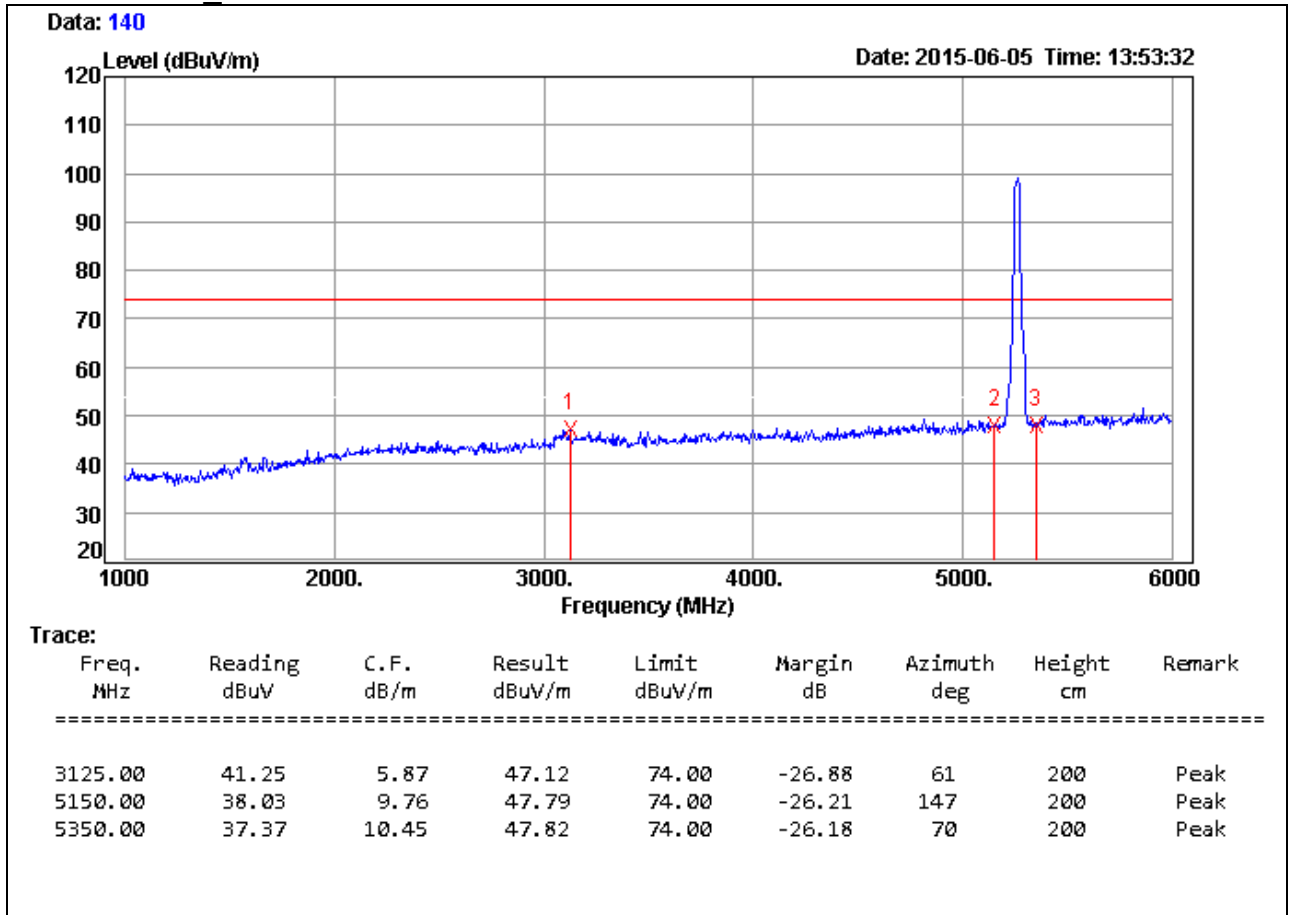

**Remark:**

1. Measuring frequencies from 1 GHz to the 10th harmonic of highest fundamental frequency.
2. Average test would be performed if the peak result were greater than the average limit.
3. Measurements above show only up to 6 maximum emissions noted, or would be lesser, with " N/A " remark, if no specific emissions from the EUT are recorded (ie: margin>20dB from the applicable limit) and considered that's already beyond the background noise floor.
4.  $Result = Reading + Correction\ Factor$   
 $Margin = Result - Limit$   
 $Remark\ Peak = Result(PK) - Limit(PK)$   
 $Remark\ AVG = Result(AV) - Limit(AV)$

<b>Product Name</b>	Computer	<b>Test By</b>	Waternil Guan
<b>Test Model</b>	POC127	<b>Test Date</b>	2015/06/04
<b>Test Mode</b>	UNII Band 2A/ IEEE 802.11a TX / CH Low	<b>Temp. &amp; Humidity</b>	26°C, 52%

966 Chamber\_C at 3Meter / Vertical

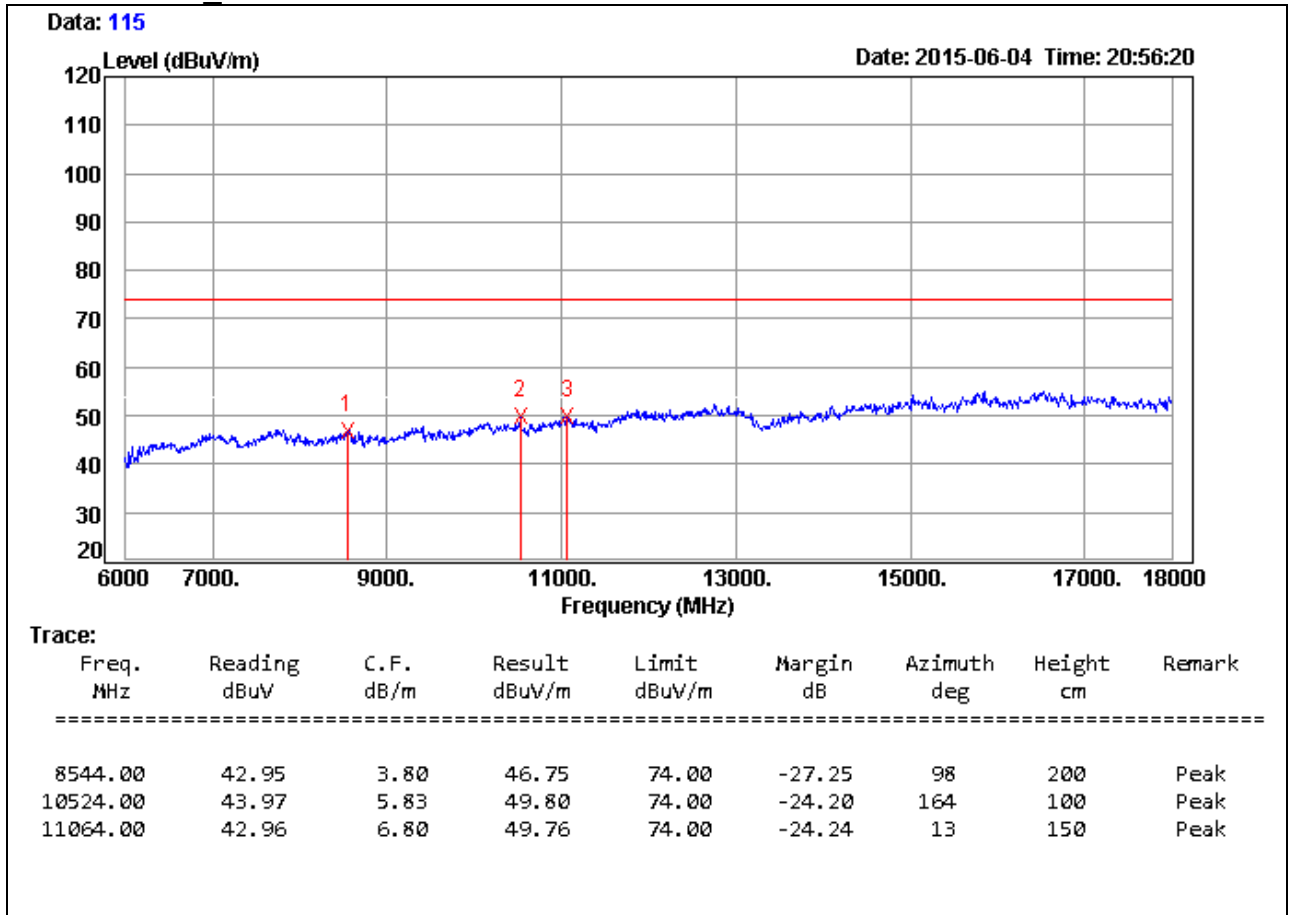

**Remark:**

1. Measuring frequencies from 1 GHz to the 10th harmonic of highest fundamental frequency.
2. Average test would be performed if the peak result were greater than the average limit.
3. Measurements above show only up to 6 maximum emissions noted, or would be lesser, with " N/A " remark, if no specific emissions from the EUT are recorded (ie: margin>20dB from the applicable limit) and considered that's already beyond the background noise floor.
4. Result = Reading + Correction Factor  
 Margin = Result - Limit  
 Remark Peak = Result(PK) - Limit(PK)  
 Remark AVG = Result(AV) - Limit(AV)
5. There is no emission in 18GHz ~ 40GHz.

<b>Product Name</b>	Computer	<b>Test By</b>	Waternil Guan
<b>Test Model</b>	POC127	<b>Test Date</b>	2015/06/05
<b>Test Mode</b>	UNII Band 2A/ IEEE 802.11a TX / CH Middle	<b>Temp. &amp; Humidity</b>	26°C, 52%

966 Chamber\_C at 3Meter / Horizontal

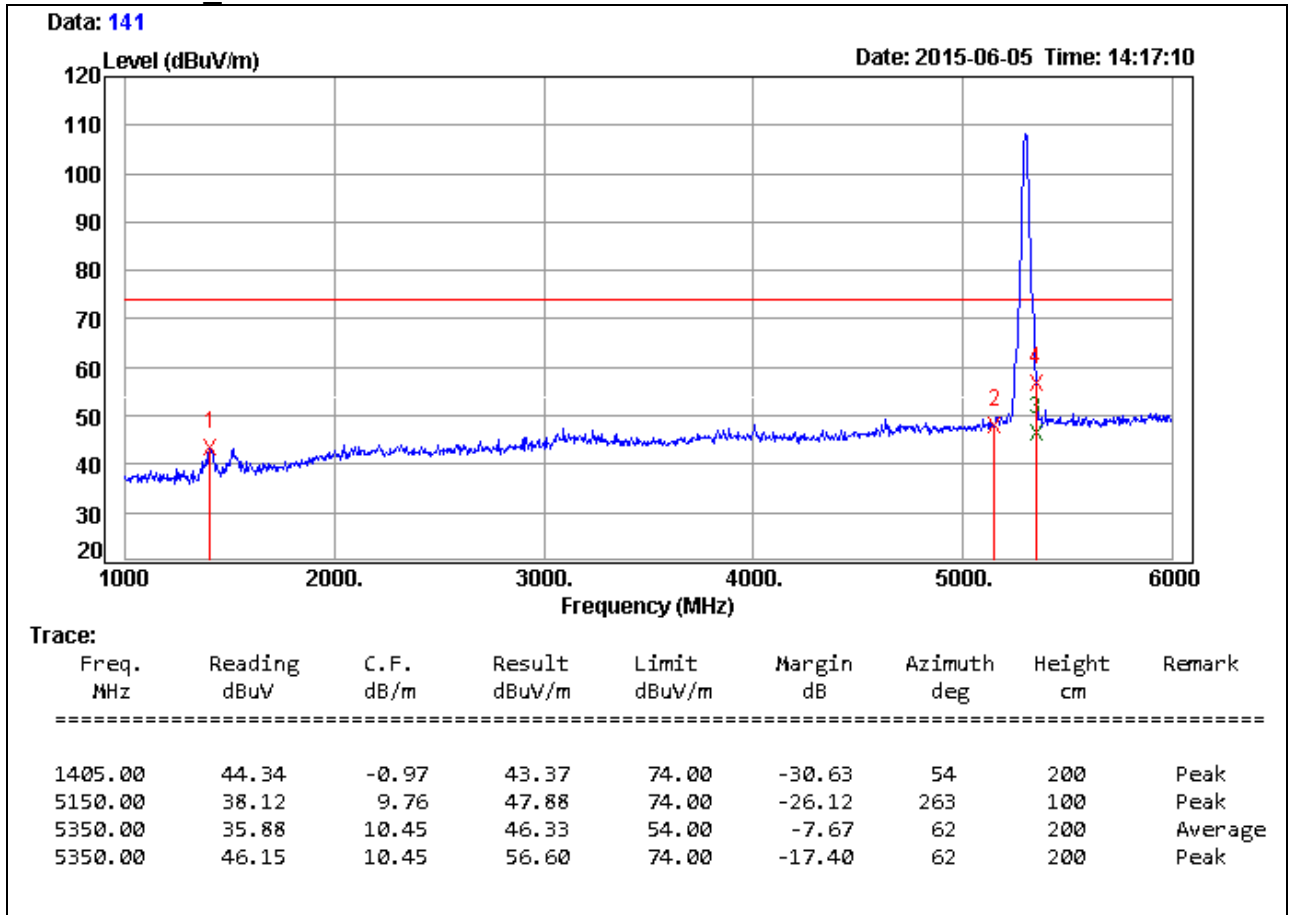

**Remark:**

1. Measuring frequencies from 1 GHz to the 10th harmonic of highest fundamental frequency.
2. Average test would be performed if the peak result were greater than the average limit.
3. Measurements above show only up to 6 maximum emissions noted, or would be lesser, with " N/A " remark, if no specific emissions from the EUT are recorded (ie: margin>20dB from the applicable limit) and considered that's already beyond the background noise floor.
4.  $Result = Reading + Correction\ Factor$   
 $Margin = Result - Limit$   
 $Remark\ Peak = Result(PK) - Limit(PK)$   
 $Remark\ AVG = Result(AV) - Limit(AV)$

<b>Product Name</b>	Computer	<b>Test By</b>	Waternil Guan
<b>Test Model</b>	POC127	<b>Test Date</b>	2015/06/04
<b>Test Mode</b>	UNII Band 2A/ IEEE 802.11a TX / CH Middle	<b>Temp. &amp; Humidity</b>	26°C, 52%

966 Chamber\_C at 3Meter / Horizontal

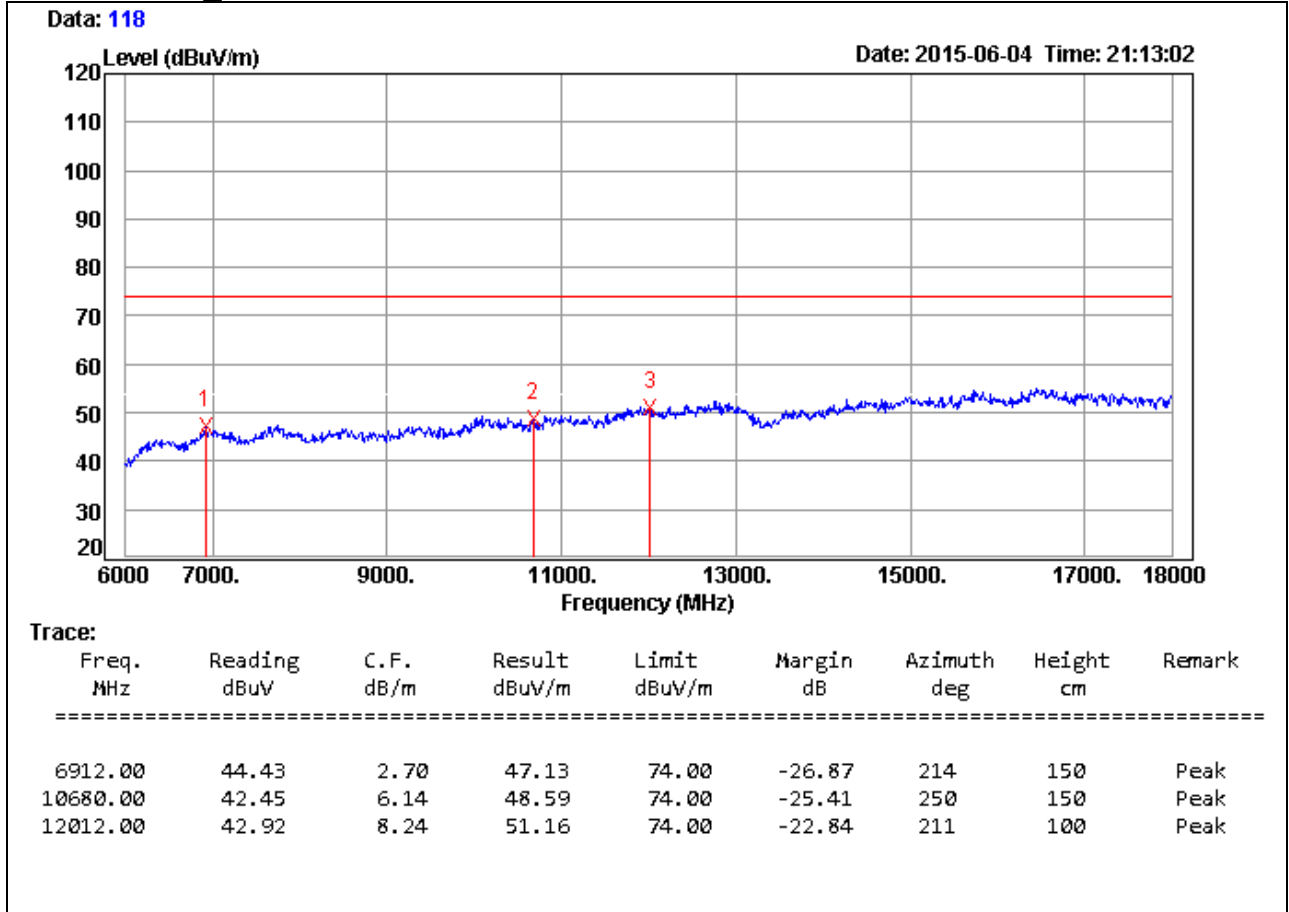

**Remark:**

1. Measuring frequencies from 1 GHz to the 10th harmonic of highest fundamental frequency.
2. Average test would be performed if the peak result were greater than the average limit.
3. Measurements above show only up to 6 maximum emissions noted, or would be lesser, with " N/A " remark, if no specific emissions from the EUT are recorded (ie: margin>20dB from the applicable limit) and considered that's already beyond the background noise floor.
4. Result = Reading + Correction Factor  
Margin = Result - Limit  
Remark Peak = Result(PK) - Limit(PK)  
Remark AVG = Result(AV) - Limit(AV)
5. There is no emission in 18GHz ~ 40GHz.

<b>Product Name</b>	Computer	<b>Test By</b>	Waternil Guan
<b>Test Model</b>	POC127	<b>Test Date</b>	2015/06/05
<b>Test Mode</b>	UNII Band 2A/ IEEE 802.11a TX / CH Middle	<b>Temp. &amp; Humidity</b>	26°C, 52%

966 Chamber\_C at 3Meter / Vertical

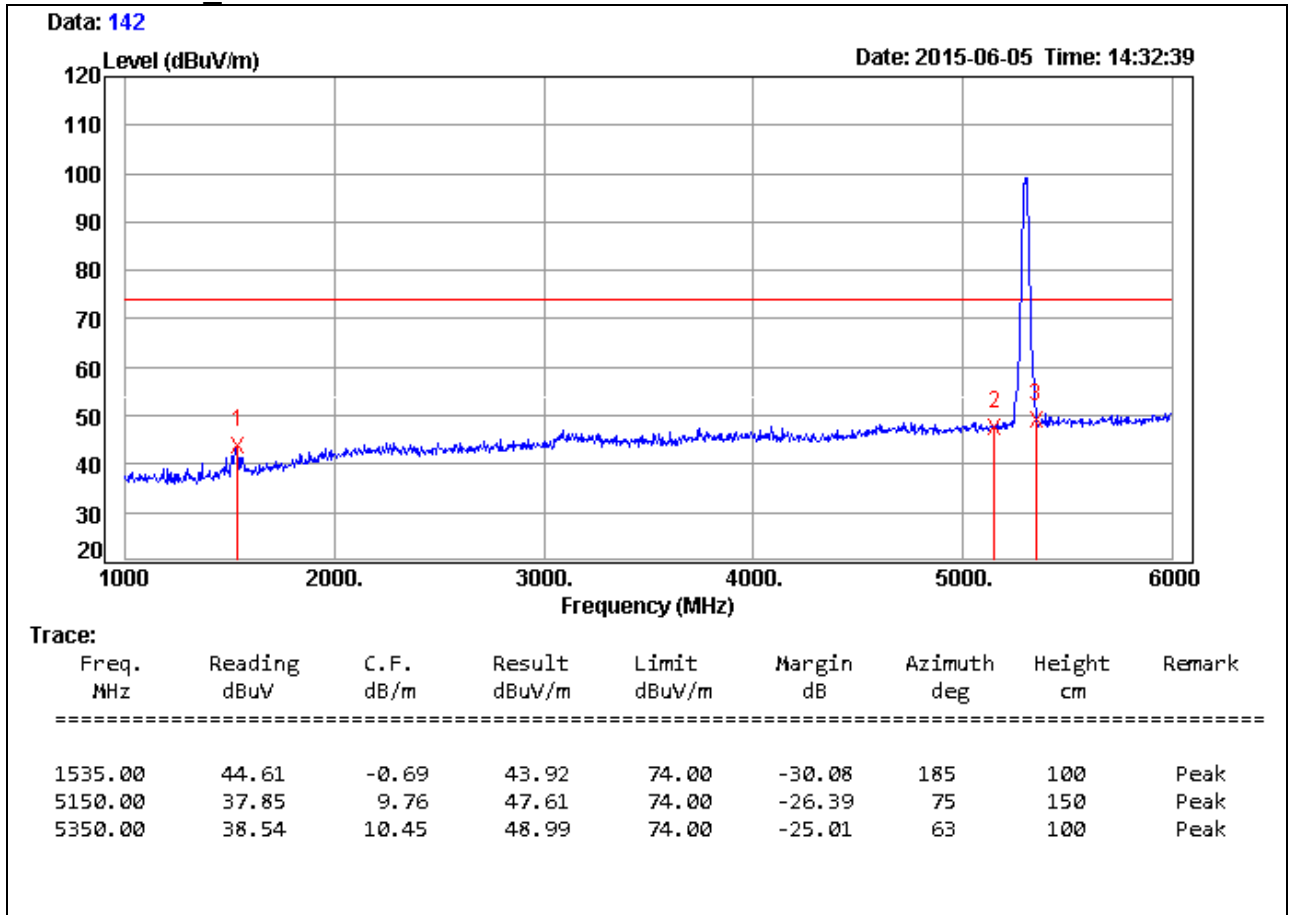

**Remark:**

1. Measuring frequencies from 1 GHz to the 10th harmonic of highest fundamental frequency.
2. Average test would be performed if the peak result were greater than the average limit.
3. Measurements above show only up to 6 maximum emissions noted, or would be lesser, with " N/A " remark, if no specific emissions from the EUT are recorded (ie: margin>20dB from the applicable limit) and considered that's already beyond the background noise floor.
4. Result = Reading + Correction Factor  
 Margin = Result - Limit  
 Remark Peak = Result(PK) - Limit(PK)  
 Remark AVG = Result(AV) - Limit(AV)

<b>Product Name</b>	Computer	<b>Test By</b>	Waternil Guan
<b>Test Model</b>	POC127	<b>Test Date</b>	2015/06/04
<b>Test Mode</b>	UNII Band 2A/ IEEE 802.11a TX / CH Middle	<b>Temp. &amp; Humidity</b>	26°C, 52%

966 Chamber\_C at 3Meter / Vertical

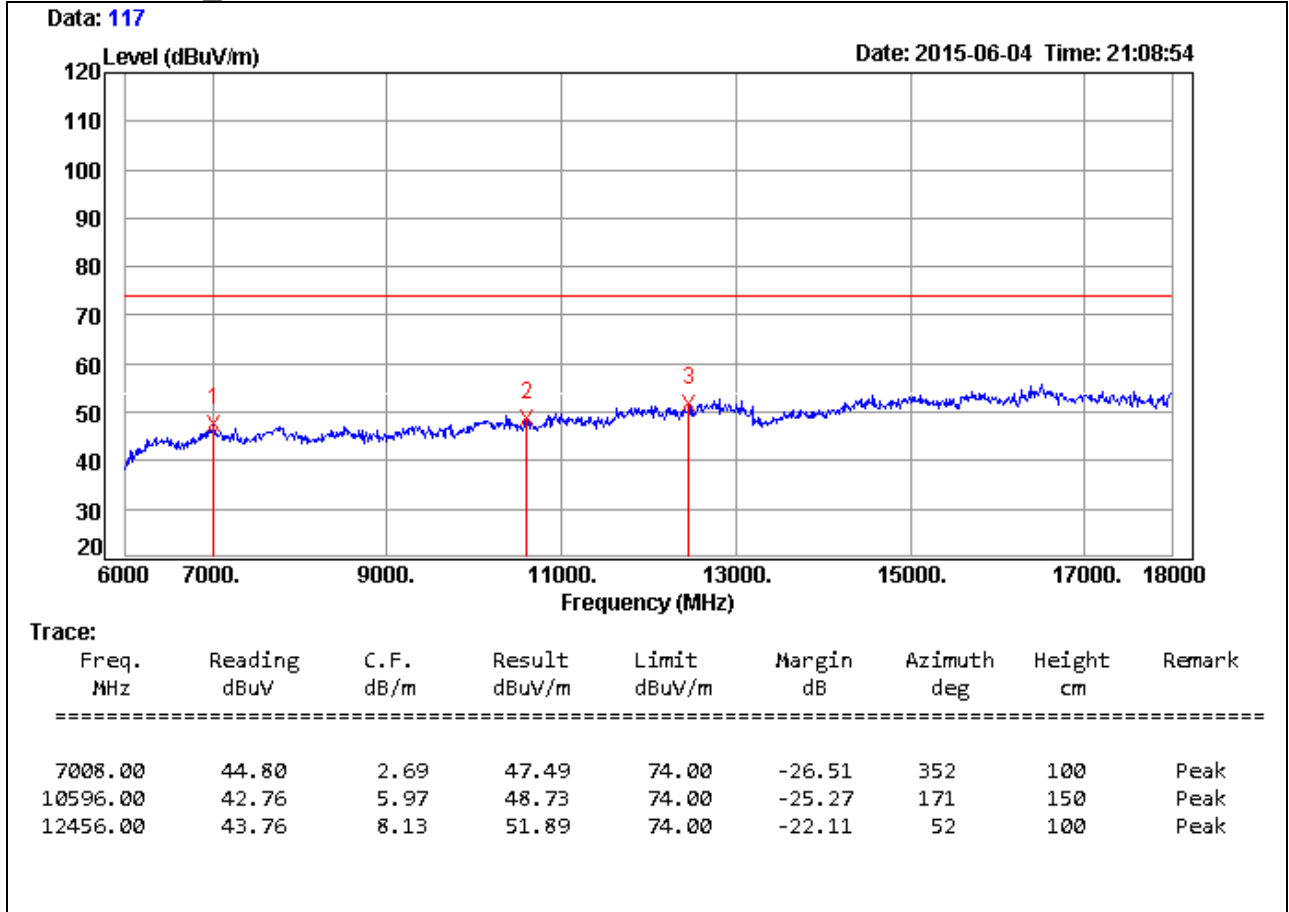

**Remark:**

1. Measuring frequencies from 1 GHz to the 10th harmonic of highest fundamental frequency.
2. Average test would be performed if the peak result were greater than the average limit.
3. Measurements above show only up to 6 maximum emissions noted, or would be lesser, with " N/A " remark, if no specific emissions from the EUT are recorded (ie: margin>20dB from the applicable limit) and considered that's already beyond the background noise floor.
4. Result = Reading + Correction Factor  
Margin = Result - Limit  
Remark Peak = Result(PK) - Limit(PK)  
Remark AVG = Result(AV) - Limit(AV)
5. There is no emission in 18GHz ~ 40GHz.

<b>Product Name</b>	Computer	<b>Test By</b>	Waternil Guan
<b>Test Model</b>	POC127	<b>Test Date</b>	2015/06/05
<b>Test Mode</b>	UNII Band 2A/ IEEE 802.11a TX / CH High	<b>Temp. &amp; Humidity</b>	26°C, 52%

966 Chamber\_C at 3Meter / Horizontal

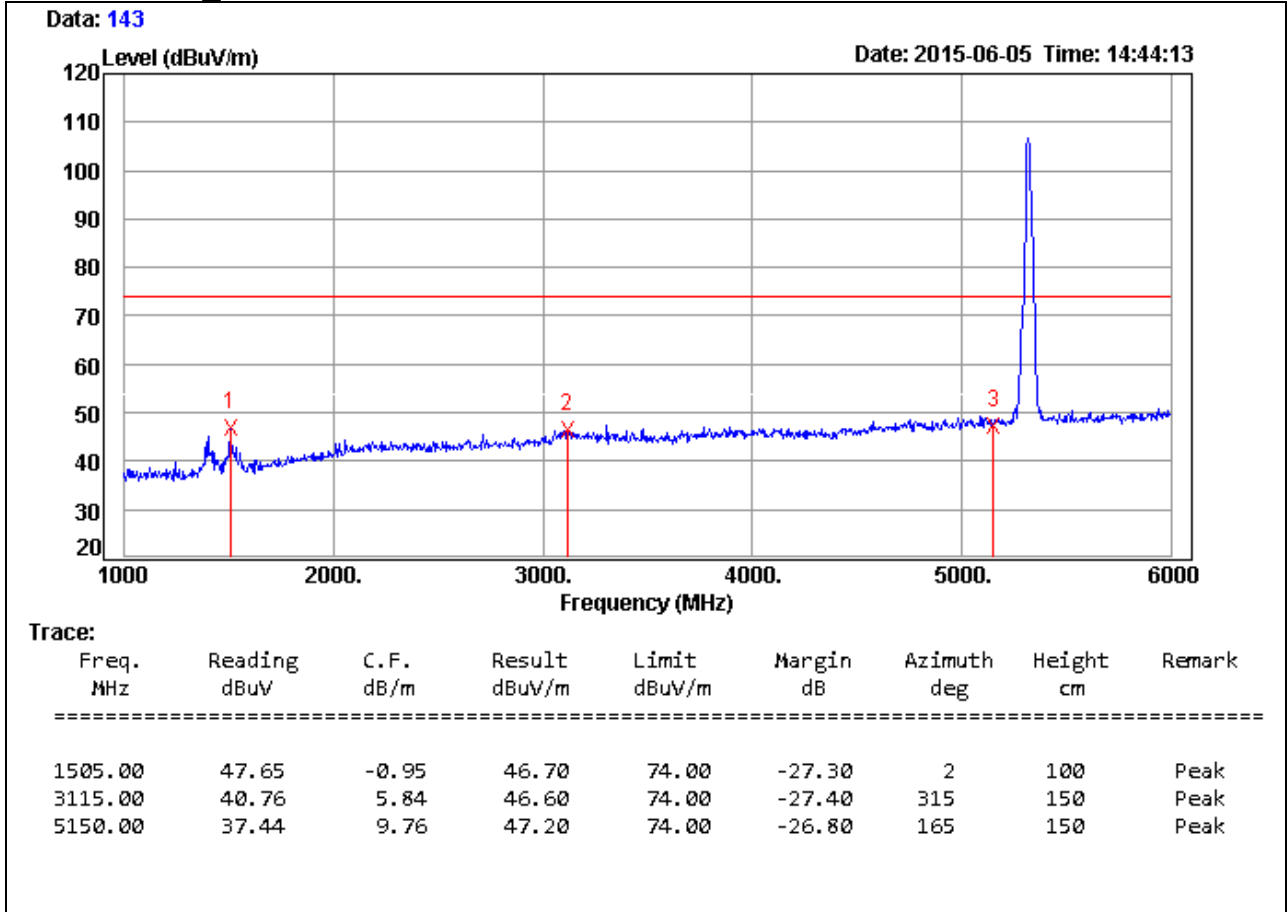

**Remark:**

1. Measuring frequencies from 1 GHz to the 10th harmonic of highest fundamental frequency.
2. Average test would be performed if the peak result were greater than the average limit.
3. Measurements above show only up to 6 maximum emissions noted, or would be lesser, with " N/A " remark, if no specific emissions from the EUT are recorded (ie: margin>20dB from the applicable limit) and considered that's already beyond the background noise floor.
4.  $Result = Reading + Correction\ Factor$   
 $Margin = Result - Limit$   
 $Remark\ Peak = Result(PK) - Limit(PK)$   
 $Remark\ AVG = Result(AV) - Limit(AV)$



<b>Product Name</b>	Computer	<b>Test By</b>	Watnail Guan
<b>Test Model</b>	POC127	<b>Test Date</b>	2015/06/04
<b>Test Mode</b>	UNII Band 2A/ IEEE 802.11a TX / CH High	<b>Temp. &amp; Humidity</b>	26°C, 52%

966 Chamber\_C at 3Meter / Horizontal

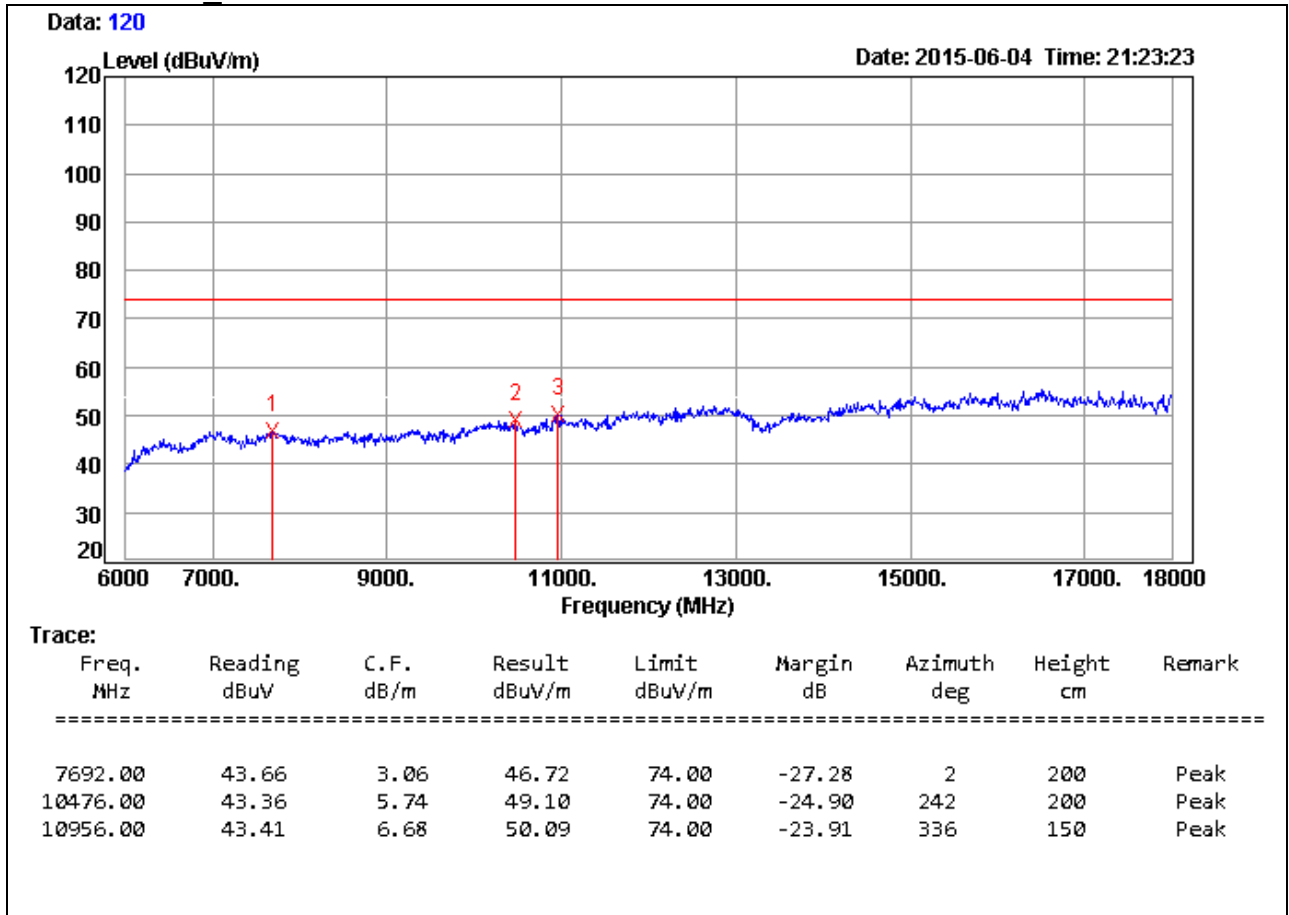

**Remark:**

1. Measuring frequencies from 1 GHz to the 10th harmonic of highest fundamental frequency.
2. Average test would be performed if the peak result were greater than the average limit.
3. Measurements above show only up to 6 maximum emissions noted, or would be lesser, with " N/A " remark, if no specific emissions from the EUT are recorded (ie: margin>20dB from the applicable limit) and considered that's already beyond the background noise floor.
4. Result = Reading + Correction Factor  
Margin = Result - Limit  
Remark Peak = Result(PK) - Limit(PK)  
Remark AVG = Result(AV) - Limit(AV)
5. There is no emission in 18GHz ~ 40GHz.

<b>Product Name</b>	Computer	<b>Test By</b>	Waternil Guan
<b>Test Model</b>	POC127	<b>Test Date</b>	2015/06/05
<b>Test Mode</b>	UNII Band 2A/ IEEE 802.11a TX / CH High	<b>Temp. &amp; Humidity</b>	26°C, 52%

966 Chamber\_C at 3Meter / Vertical

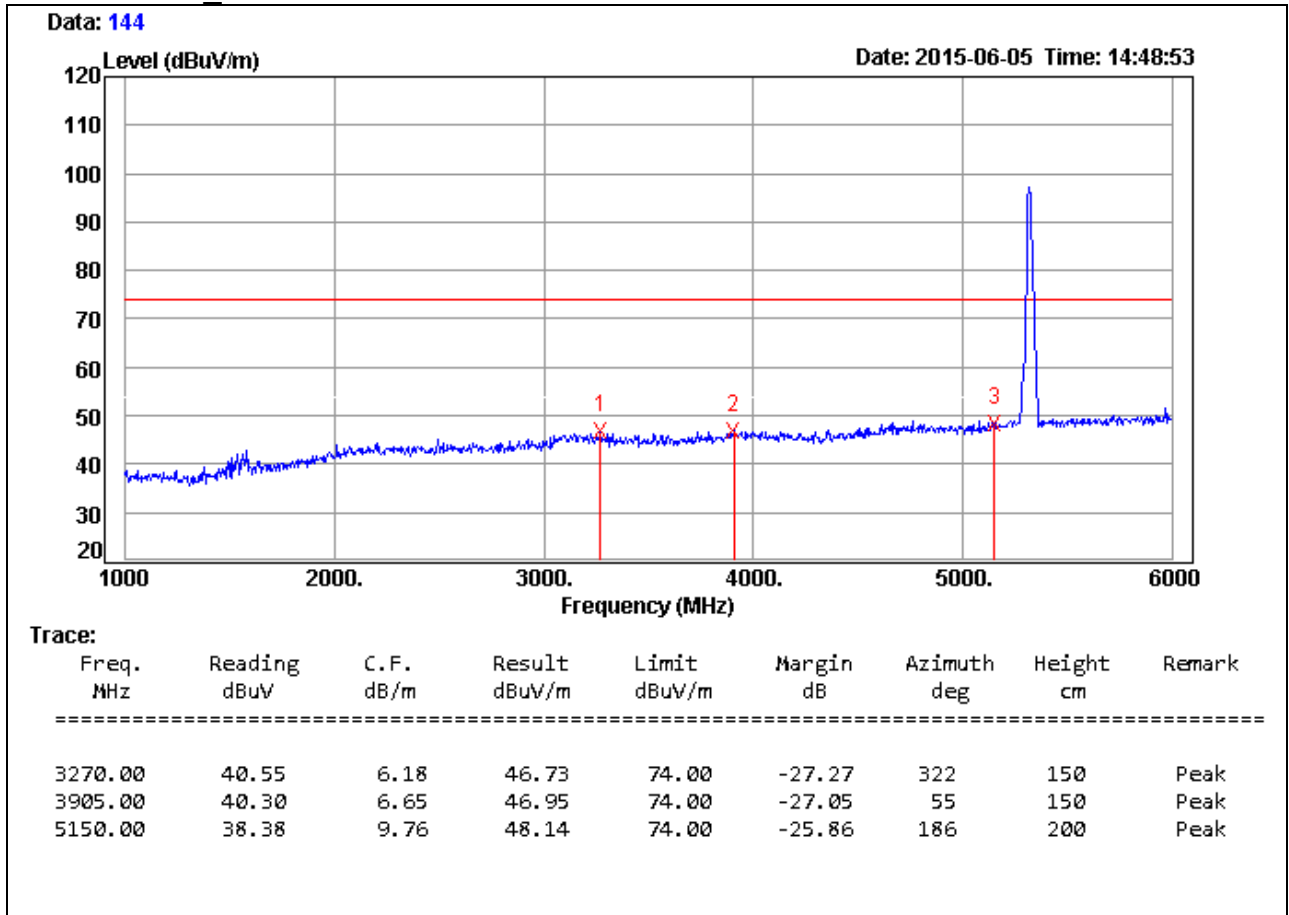

**Remark:**

1. Measuring frequencies from 1 GHz to the 10th harmonic of highest fundamental frequency.
2. Average test would be performed if the peak result were greater than the average limit.
3. Measurements above show only up to 6 maximum emissions noted, or would be lesser, with " N/A " remark, if no specific emissions from the EUT are recorded (ie: margin>20dB from the applicable limit) and considered that's already beyond the background noise floor.
4.  $Result = Reading + Correction\ Factor$   
 $Margin = Result - Limit$   
 $Remark\ Peak = Result(PK) - Limit(PK)$   
 $Remark\ AVG = Result(AV) - Limit(AV)$

<b>Product Name</b>	Computer	<b>Test By</b>	Waternil Guan
<b>Test Model</b>	POC127	<b>Test Date</b>	2015/06/04
<b>Test Mode</b>	UNII Band 2A/ IEEE 802.11a TX / CH High	<b>Temp. &amp; Humidity</b>	26°C, 52%

966 Chamber\_C at 3Meter / Vertical

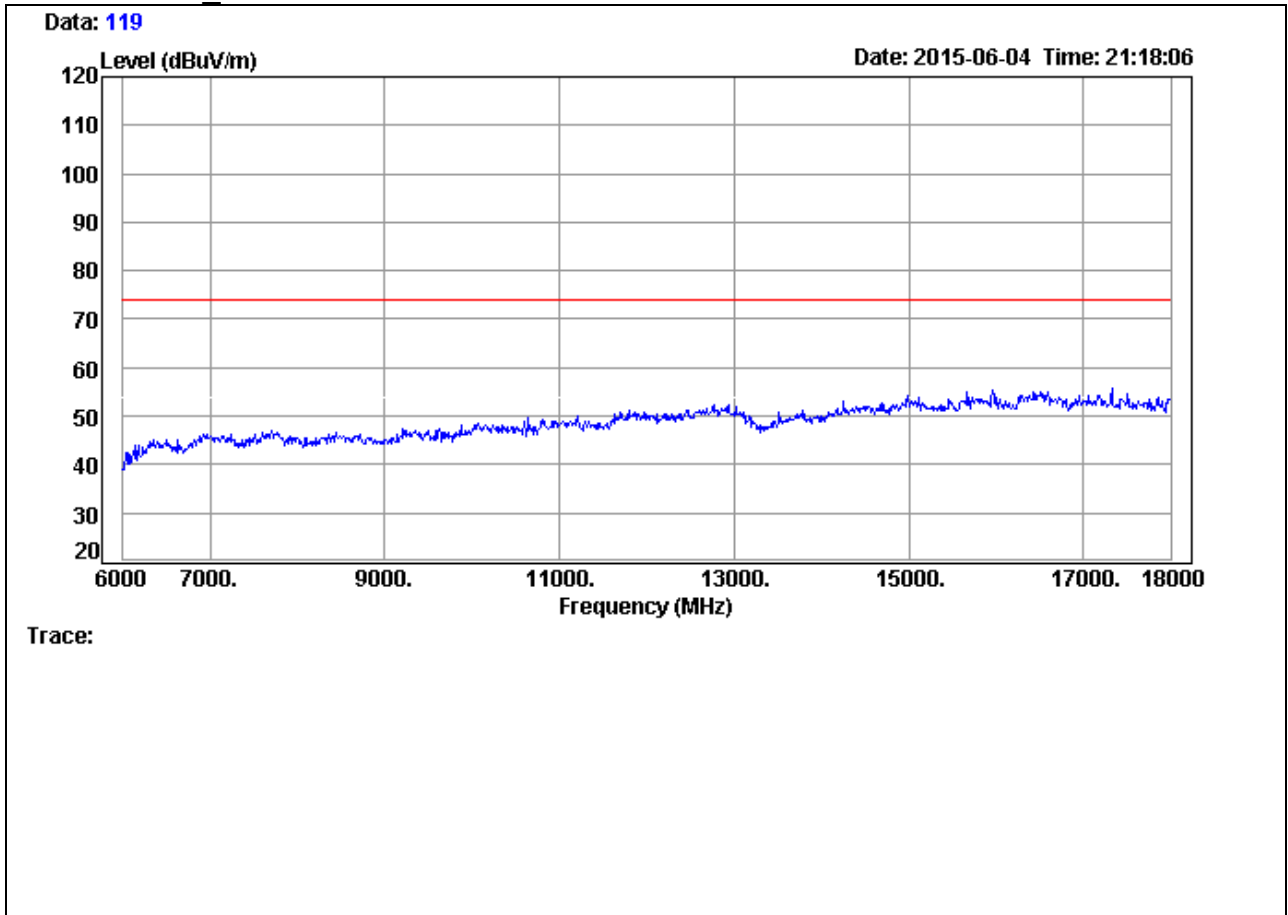

**Remark:**

1. Measuring frequencies from 1 GHz to the 10th harmonic of highest fundamental frequency.
2. Average test would be performed if the peak result were greater than the average limit.
3. Measurements above show only up to 6 maximum emissions noted, or would be lesser, with " N/A " remark, if no specific emissions from the EUT are recorded (ie: margin>20dB from the applicable limit) and considered that's already beyond the background noise floor.
4. Result = Reading + Correction Factor  
 Margin = Result – Limit  
 Remark Peak = Result(PK) – Limit(PK)  
 Remark AVG = Result(AV) – Limit(AV)
5. There is no emission in 18GHz ~ 40GHz.

<b>Product Name</b>	Computer	<b>Test By</b>	Waternil Guan
<b>Test Model</b>	POC127	<b>Test Date</b>	2015/06/09
<b>Test Mode</b>	UNII Band 2A/ IEEE 802.11an HT20 TX / CH Low	<b>Temp. &amp; Humidity</b>	26°C, 52%

966 Chamber\_C at 3Meter / Horizontal

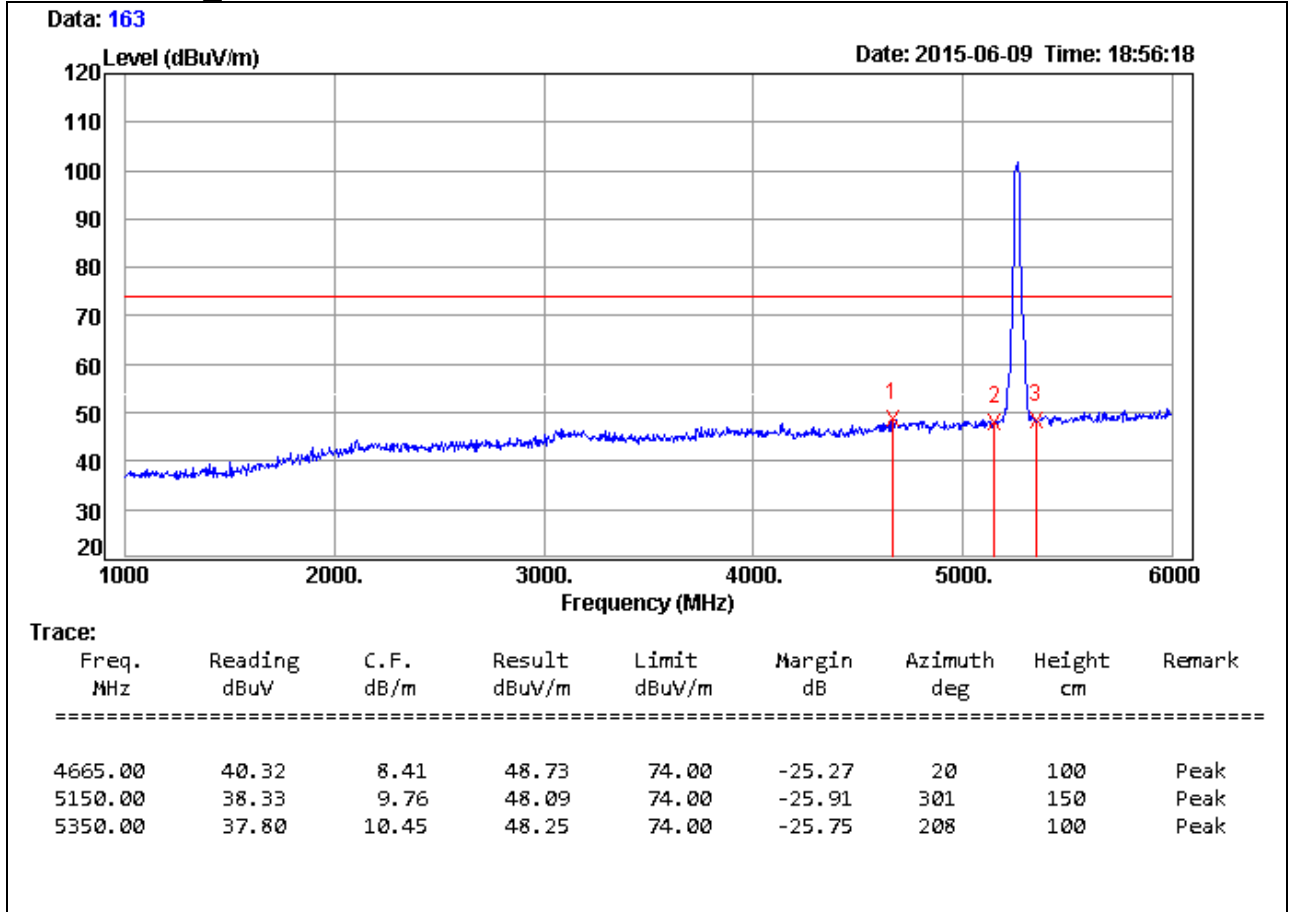

**Remark:**

1. Measuring frequencies from 1 GHz to the 10th harmonic of highest fundamental frequency.
2. Average test would be performed if the peak result were greater than the average limit.
3. Measurements above show only up to 6 maximum emissions noted, or would be lesser, with " N/A " remark, if no specific emissions from the EUT are recorded (ie: margin>20dB from the applicable limit) and considered that's already beyond the background noise floor.
4.  $Result = Reading + Correction\ Factor$   
 $Margin = Result - Limit$   
 $Remark\ Peak = Result(PK) - Limit(PK)$   
 $Remark\ AVG = Result(AV) - Limit(AV)$

<b>Product Name</b>	Computer	<b>Test By</b>	Waternil Guan
<b>Test Model</b>	POC127	<b>Test Date</b>	2015/06/10
<b>Test Mode</b>	UNII Band 2A/ IEEE 802.11an HT20 TX / CH Low	<b>Temp. &amp; Humidity</b>	26°C, 52%

966 Chamber\_C at 3Meter / Horizontal

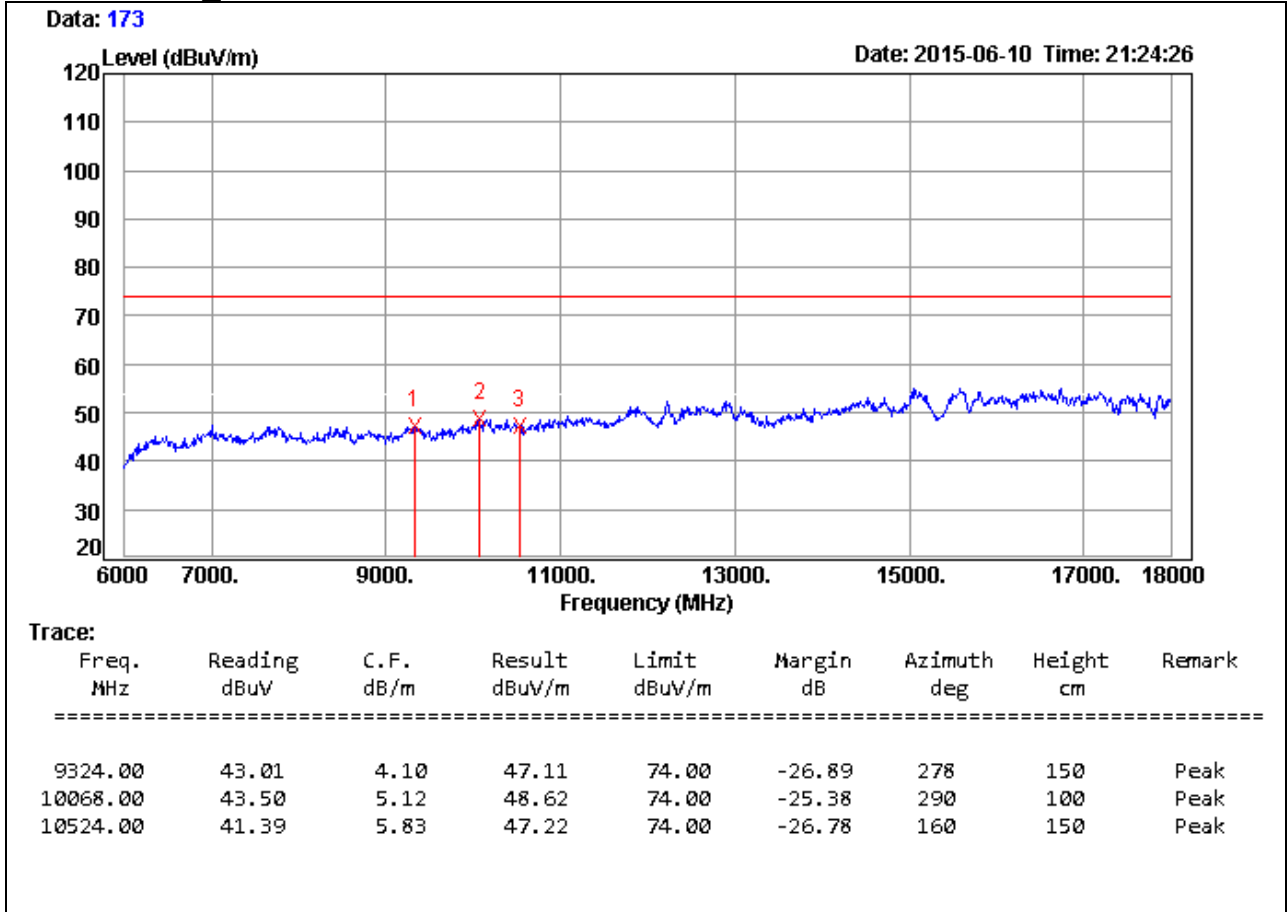

**Remark:**

1. Measuring frequencies from 1 GHz to the 10th harmonic of highest fundamental frequency.
2. Average test would be performed if the peak result were greater than the average limit.
3. Measurements above show only up to 6 maximum emissions noted, or would be lesser, with " N/A " remark, if no specific emissions from the EUT are recorded (ie: margin>20dB from the applicable limit) and considered that's already beyond the background noise floor.
4. Result = Reading + Correction Factor  
Margin = Result - Limit  
Remark Peak = Result(PK) - Limit(PK)  
Remark AVG = Result(AV) - Limit(AV)
5. There is no emission in 18GHz ~ 40GHz.

<b>Product Name</b>	Computer	<b>Test By</b>	Waternil Guan
<b>Test Model</b>	POC127	<b>Test Date</b>	2015/06/09
<b>Test Mode</b>	UNII Band 2A/ IEEE 802.11an HT20 TX / CH Low	<b>Temp. &amp; Humidity</b>	26°C, 52%

966 Chamber\_C at 3Meter / Vertical

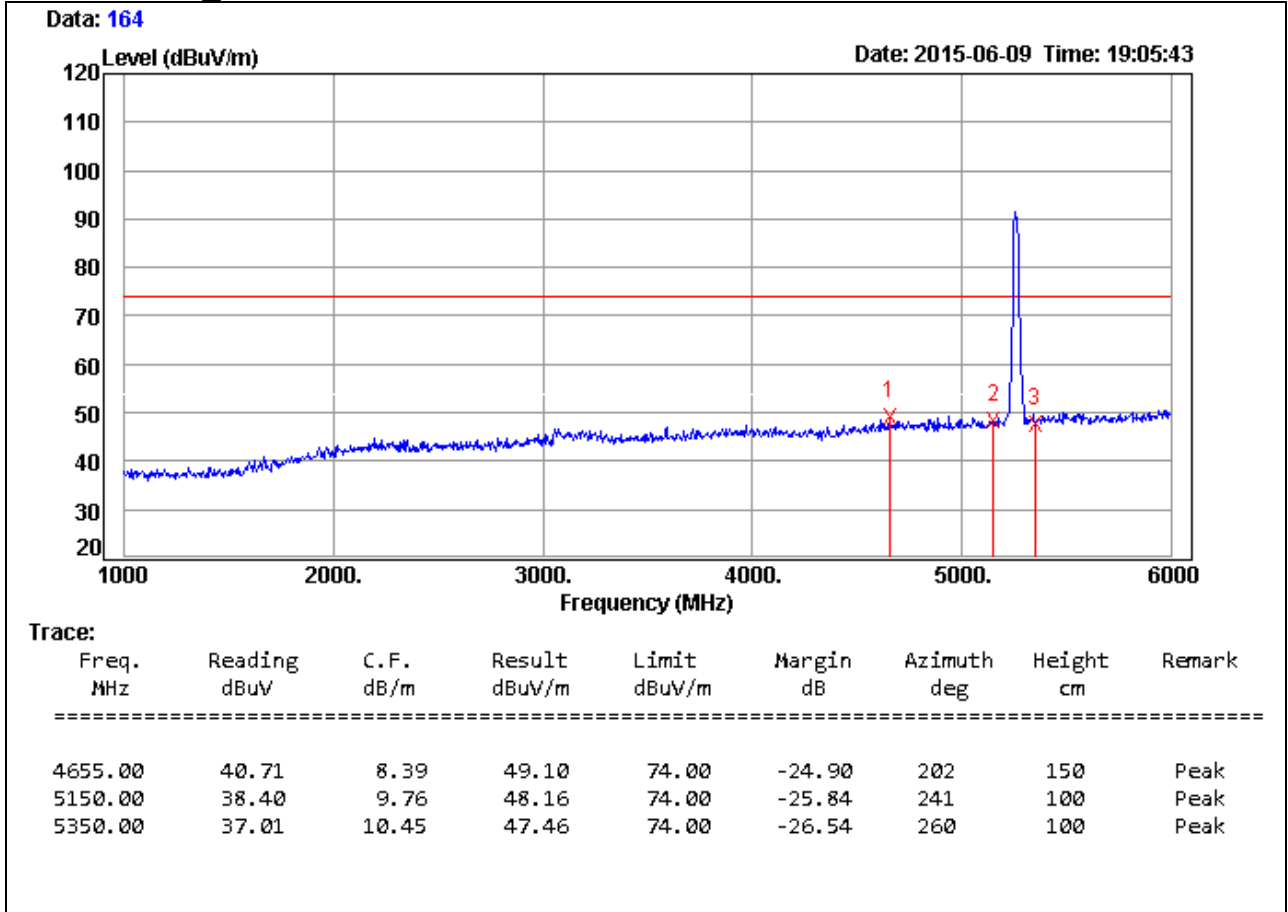

**Remark:**

1. Measuring frequencies from 1 GHz to the 10th harmonic of highest fundamental frequency.
2. Average test would be performed if the peak result were greater than the average limit.
3. Measurements above show only up to 6 maximum emissions noted, or would be lesser, with " N/A " remark, if no specific emissions from the EUT are recorded (ie: margin>20dB from the applicable limit) and considered that's already beyond the background noise floor.
4.  $Result = Reading + Correction\ Factor$   
 $Margin = Result - Limit$   
 $Remark\ Peak = Result(PK) - Limit(PK)$   
 $Remark\ AVG = Result(AV) - Limit(AV)$

<b>Product Name</b>	Computer	<b>Test By</b>	Waternil Guan
<b>Test Model</b>	POC127	<b>Test Date</b>	2015/06/10
<b>Test Mode</b>	UNII Band 2A/ IEEE 802.11an HT20 TX / CH Low	<b>Temp. &amp; Humidity</b>	26°C, 52%

966 Chamber\_C at 3Meter / Vertical

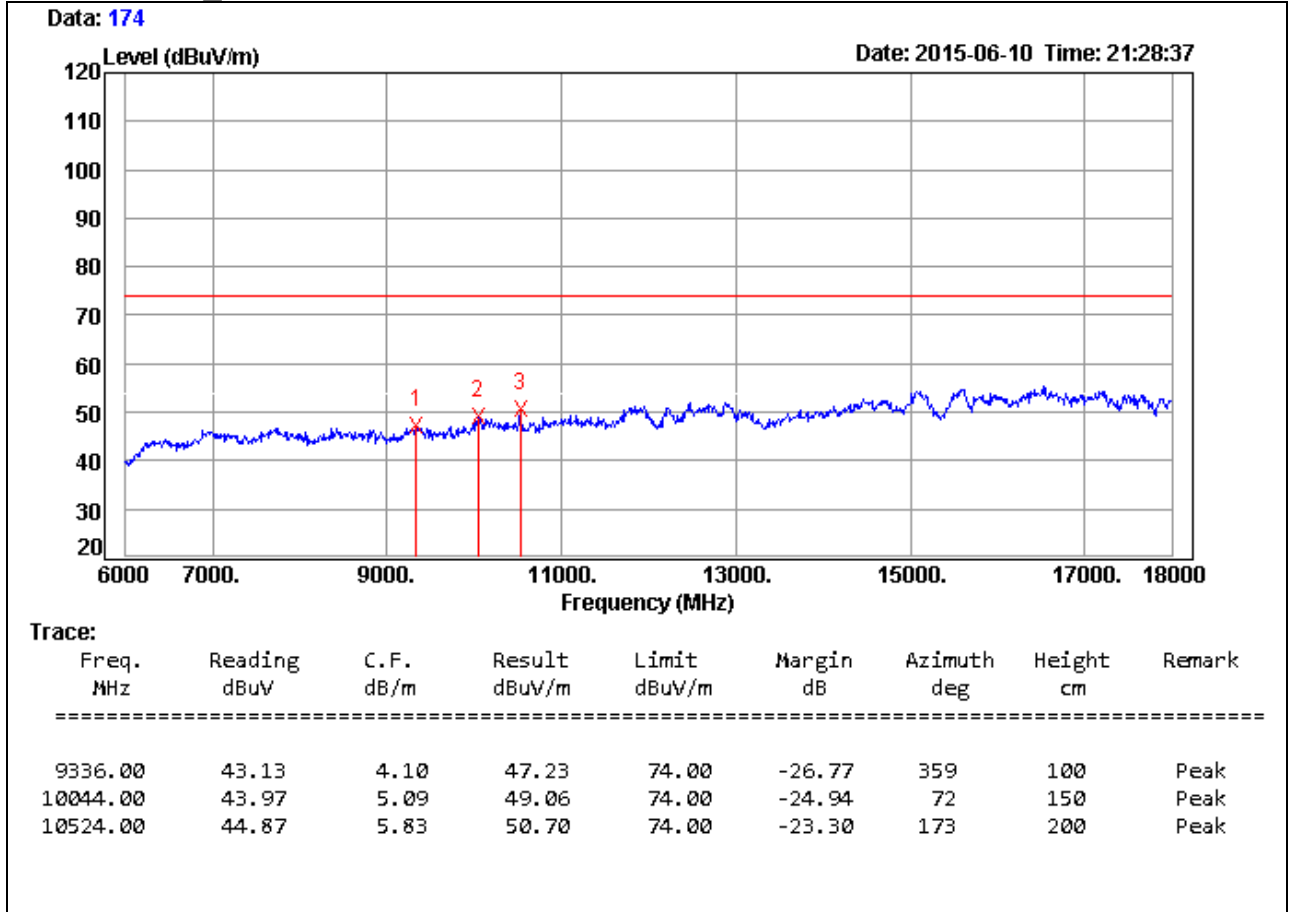

**Remark:**

1. Measuring frequencies from 1 GHz to the 10th harmonic of highest fundamental frequency.
2. Average test would be performed if the peak result were greater than the average limit.
3. Measurements above show only up to 6 maximum emissions noted, or would be lesser, with " N/A " remark, if no specific emissions from the EUT are recorded (ie: margin>20dB from the applicable limit) and considered that's already beyond the background noise floor.
4. Result = Reading + Correction Factor  
 Margin = Result – Limit  
 Remark Peak = Result(PK) – Limit(PK)  
 Remark AVG = Result(AV) – Limit(AV)
5. There is no emission in 18GHz ~ 40GHz.

<b>Product Name</b>	Computer	<b>Test By</b>	Waternil Guan
<b>Test Model</b>	POC127	<b>Test Date</b>	2015/06/09
<b>Test Mode</b>	UNII Band 2A/ IEEE 802.11an HT20 TX / CH Middle	<b>Temp. &amp; Humidity</b>	26°C, 52%

966 Chamber\_C at 3Meter / Horizontal

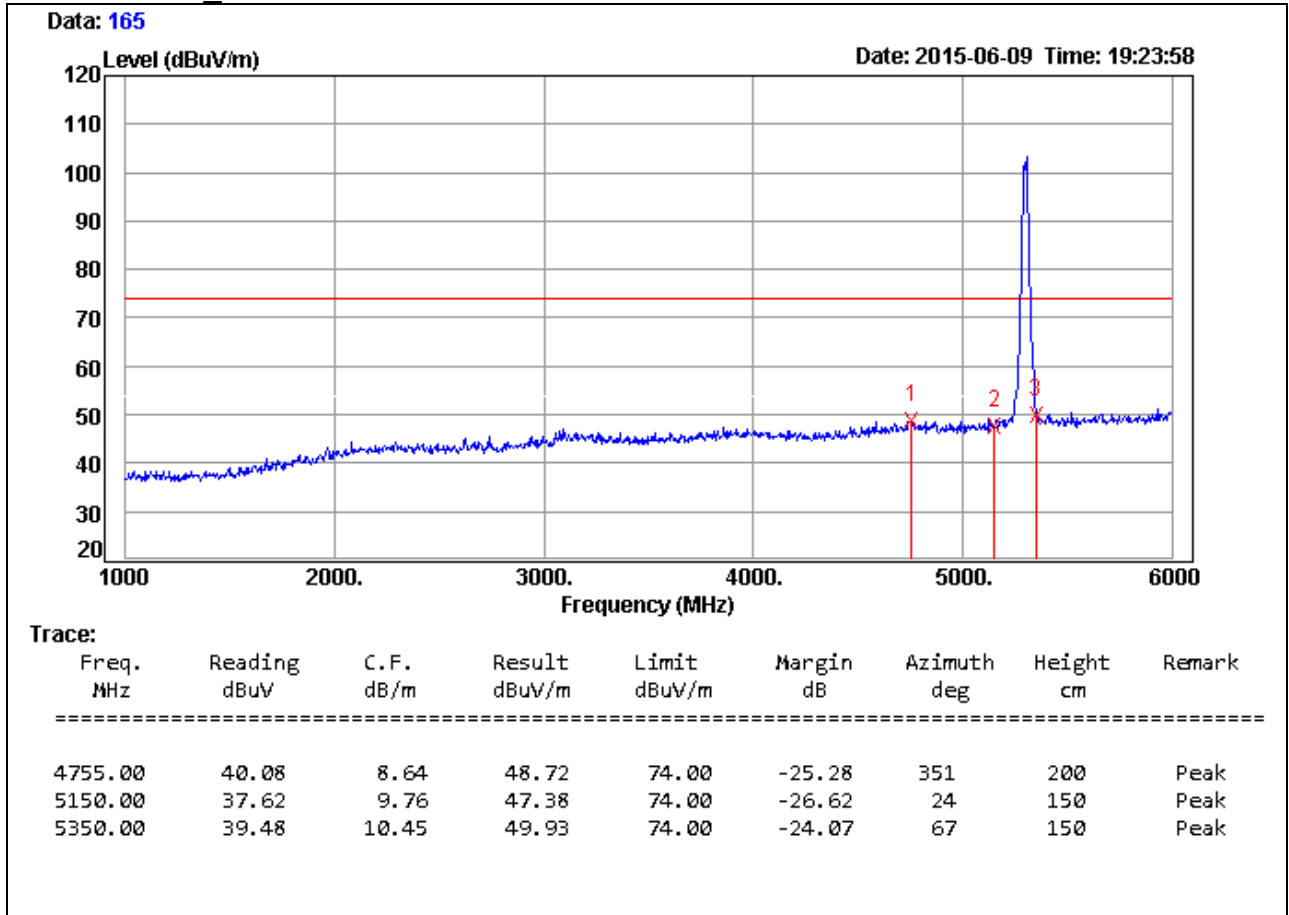

**Remark:**

1. Measuring frequencies from 1 GHz to the 10th harmonic of highest fundamental frequency.
2. Average test would be performed if the peak result were greater than the average limit.
3. Measurements above show only up to 6 maximum emissions noted, or would be lesser, with " N/A " remark, if no specific emissions from the EUT are recorded (ie: margin>20dB from the applicable limit) and considered that's already beyond the background noise floor.
4. Result = Reading + Correction Factor  
 Margin = Result - Limit  
 Remark Peak = Result(PK) - Limit(PK)  
 Remark AVG = Result(AV) - Limit(AV)



<b>Product Name</b>	Computer	<b>Test By</b>	Waternil Guan
<b>Test Model</b>	POC127	<b>Test Date</b>	2015/06/10
<b>Test Mode</b>	UNII Band 2A/ IEEE 802.11an HT20 TX / CH Middle	<b>Temp. &amp; Humidity</b>	26°C, 52%

966 Chamber\_C at 3Meter / Horizontal

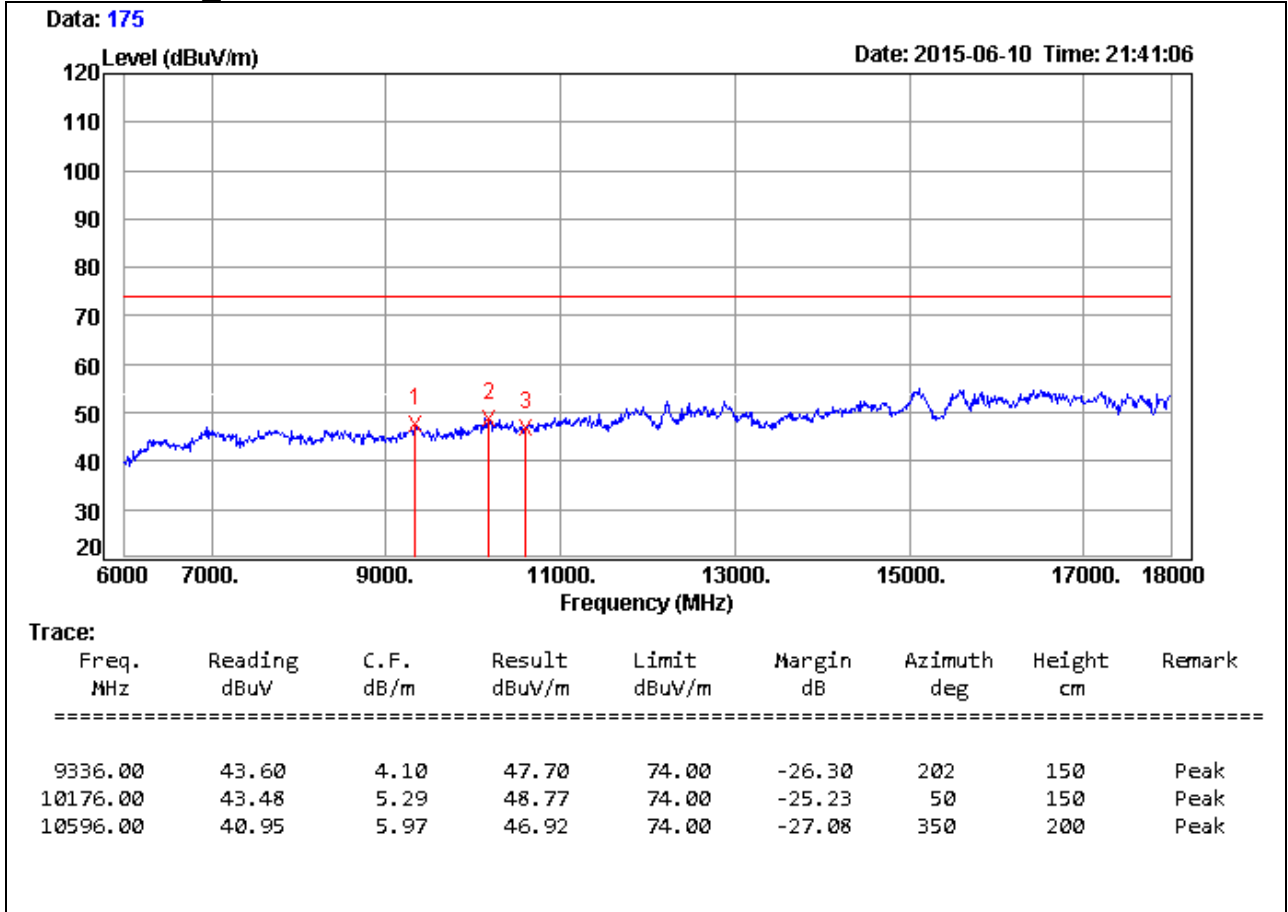

**Remark:**

1. Measuring frequencies from 1 GHz to the 10th harmonic of highest fundamental frequency.
2. Average test would be performed if the peak result were greater than the average limit.
3. Measurements above show only up to 6 maximum emissions noted, or would be lesser, with " N/A " remark, if no specific emissions from the EUT are recorded (ie: margin>20dB from the applicable limit) and considered that's already beyond the background noise floor.
4. Result = Reading + Correction Factor  
Margin = Result - Limit  
Remark Peak = Result(PK) - Limit(PK)  
Remark AVG = Result(AV) - Limit(AV)
5. There is no emission in 18GHz ~ 40GHz.

<b>Product Name</b>	Computer	<b>Test By</b>	Waternil Guan
<b>Test Model</b>	POC127	<b>Test Date</b>	2015/06/09
<b>Test Mode</b>	UNII Band 2A/ IEEE 802.11an HT20 TX / CH Middle	<b>Temp. &amp; Humidity</b>	26°C, 52%

966 Chamber\_C at 3Meter / Vertical

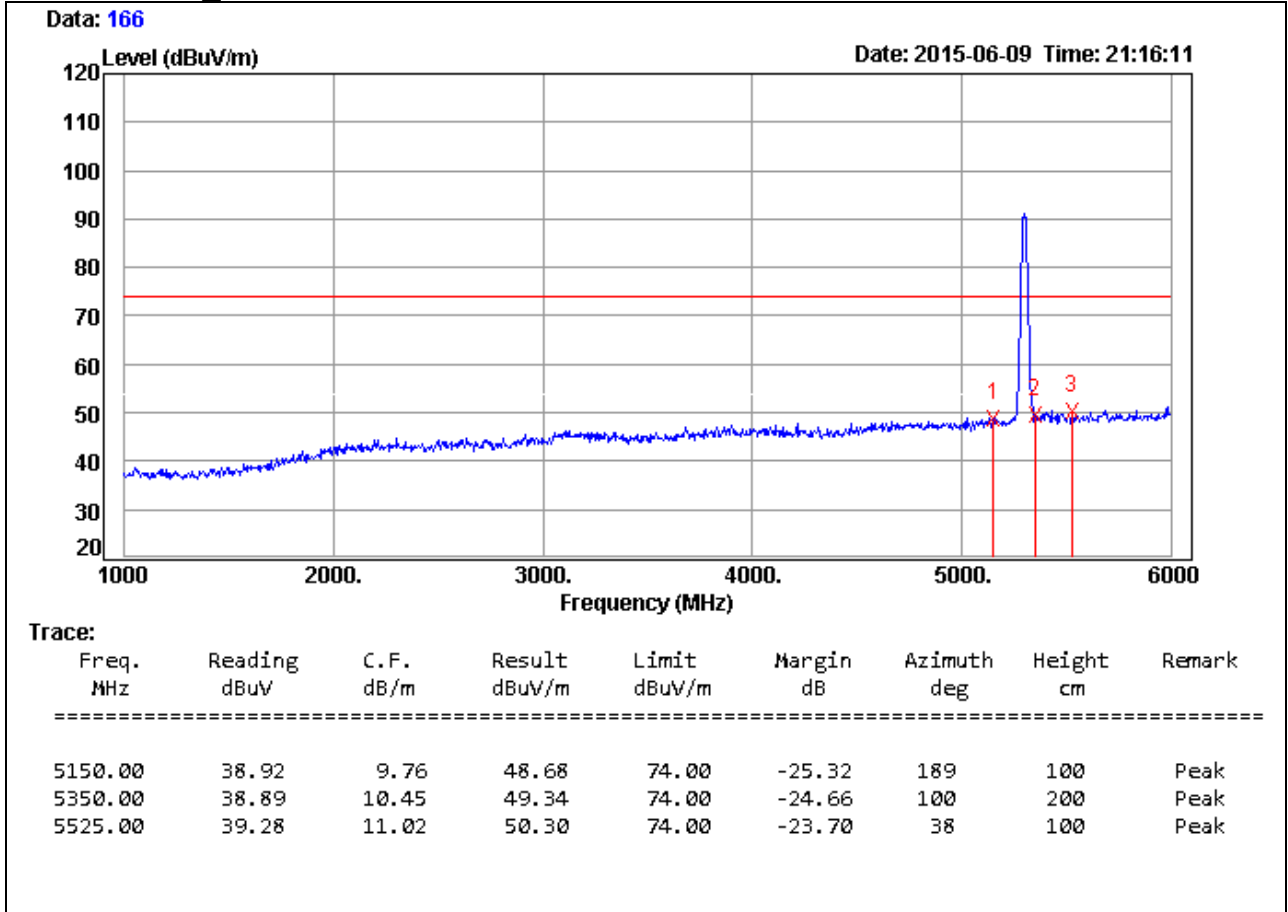

**Remark:**

1. Measuring frequencies from 1 GHz to the 10th harmonic of highest fundamental frequency.
2. Average test would be performed if the peak result were greater than the average limit.
3. Measurements above show only up to 6 maximum emissions noted, or would be lesser, with " N/A " remark, if no specific emissions from the EUT are recorded (ie: margin>20dB from the applicable limit) and considered that's already beyond the background noise floor.
4.  $Result = Reading + Correction\ Factor$   
 $Margin = Result - Limit$   
 $Remark\ Peak = Result(PK) - Limit(PK)$   
 $Remark\ AVG = Result(AV) - Limit(AV)$

<b>Product Name</b>	Computer	<b>Test By</b>	Waternil Guan
<b>Test Model</b>	POC127	<b>Test Date</b>	2015/06/10
<b>Test Mode</b>	UNII Band 2A/ IEEE 802.11an HT20 TX / CH Middle	<b>Temp. &amp; Humidity</b>	26°C, 52%

966 Chamber\_C at 3Meter / Vertical

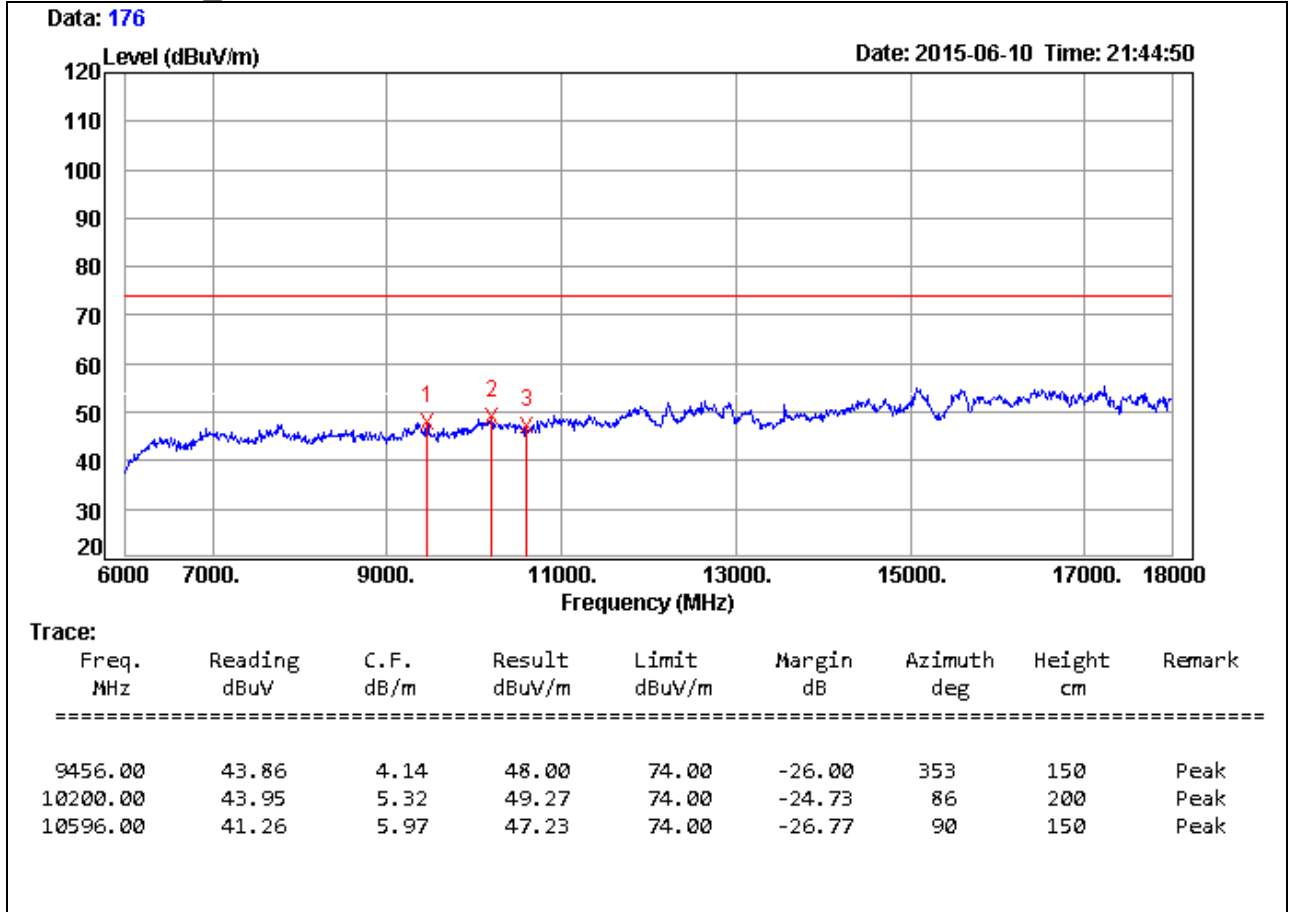

**Remark:**

1. Measuring frequencies from 1 GHz to the 10th harmonic of highest fundamental frequency.
2. Average test would be performed if the peak result were greater than the average limit.
3. Measurements above show only up to 6 maximum emissions noted, or would be lesser, with " N/A " remark, if no specific emissions from the EUT are recorded (ie: margin>20dB from the applicable limit) and considered that's already beyond the background noise floor.
4. Result = Reading + Correction Factor  
Margin = Result - Limit  
Remark Peak = Result(PK) - Limit(PK)  
Remark AVG = Result(AV) - Limit(AV)
5. There is no emission in 18GHz ~ 40GHz.

<b>Product Name</b>	Computer	<b>Test By</b>	Waternil Guan
<b>Test Model</b>	POC127	<b>Test Date</b>	2015/06/18
<b>Test Mode</b>	UNII Band 2A/ IEEE 802.11an HT20 TX / CH High	<b>Temp. &amp; Humidity</b>	26°C, 52%

966 Chamber\_C at 3Meter / Horizontal

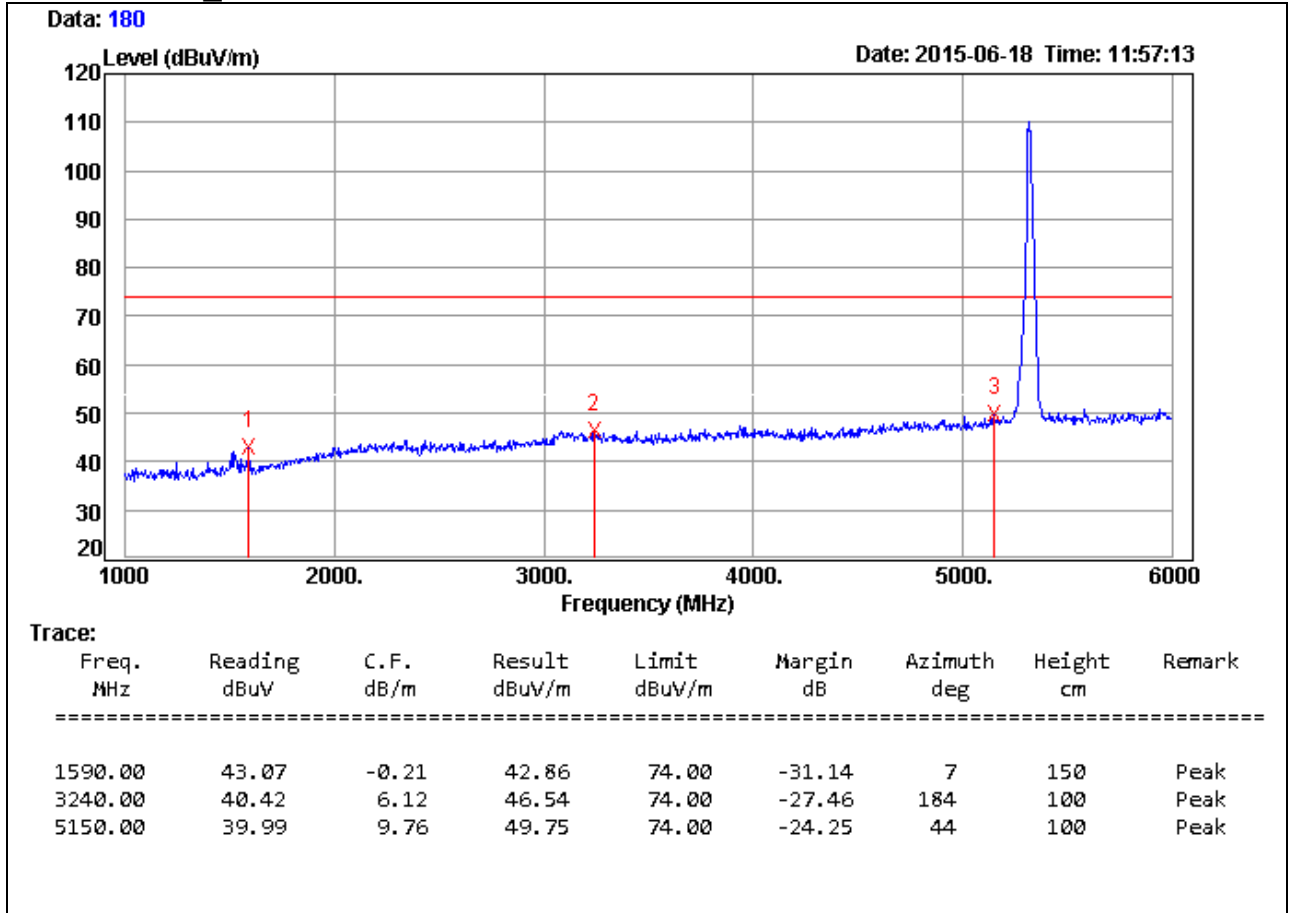

**Remark:**

1. Measuring frequencies from 1 GHz to the 10th harmonic of highest fundamental frequency.
2. Average test would be performed if the peak result were greater than the average limit.
3. Measurements above show only up to 6 maximum emissions noted, or would be lesser, with " N/A " remark, if no specific emissions from the EUT are recorded (ie: margin>20dB from the applicable limit) and considered that's already beyond the background noise floor.
4. Result = Reading + Correction Factor  
Margin = Result - Limit  
Remark Peak = Result(PK) - Limit(PK)  
Remark AVG = Result(AV) - Limit(AV)

<b>Product Name</b>	Computer	<b>Test By</b>	Waternil Guan
<b>Test Model</b>	POC127	<b>Test Date</b>	2015/06/10
<b>Test Mode</b>	UNII Band 2A/ IEEE 802.11an HT20 TX / CH High	<b>Temp. &amp; Humidity</b>	26°C, 52%

966 Chamber\_C at 3Meter / Horizontal

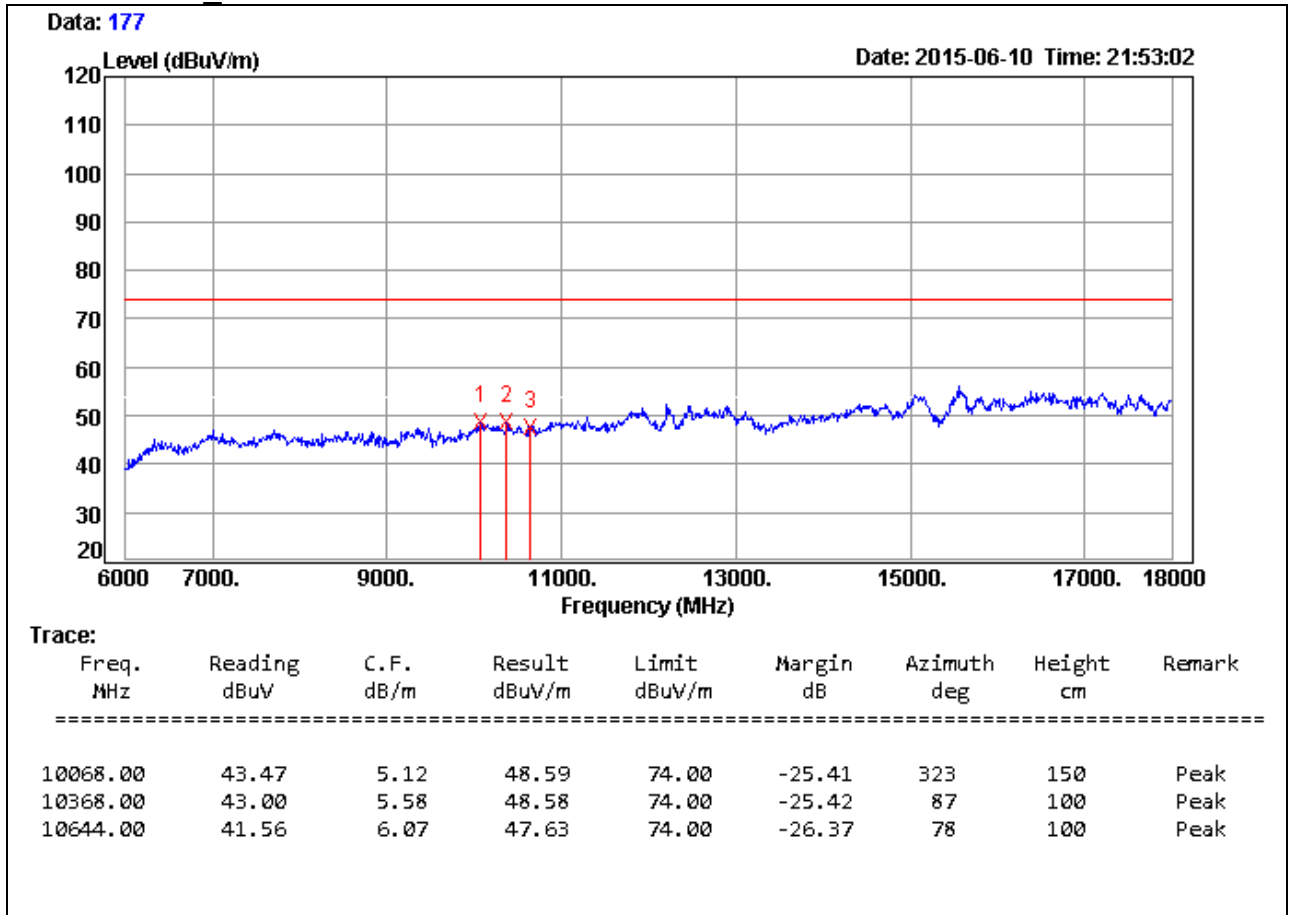

**Remark:**

1. Measuring frequencies from 1 GHz to the 10th harmonic of highest fundamental frequency.
2. Average test would be performed if the peak result were greater than the average limit.
3. Measurements above show only up to 6 maximum emissions noted, or would be lesser, with " N/A " remark, if no specific emissions from the EUT are recorded (ie: margin>20dB from the applicable limit) and considered that's already beyond the background noise floor.
4. Result = Reading + Correction Factor  
Margin = Result - Limit  
Remark Peak = Result(PK) - Limit(PK)  
Remark AVG = Result(AV) - Limit(AV)
5. There is no emission in 18GHz ~ 40GHz.

<b>Product Name</b>	Computer	<b>Test By</b>	Waternil Guan
<b>Test Model</b>	POC127	<b>Test Date</b>	2015/06/18
<b>Test Mode</b>	UNII Band 2A/ IEEE 802.11an HT20 TX / CH High	<b>Temp. &amp; Humidity</b>	26°C, 52%

966 Chamber\_C at 3Meter / Vertical

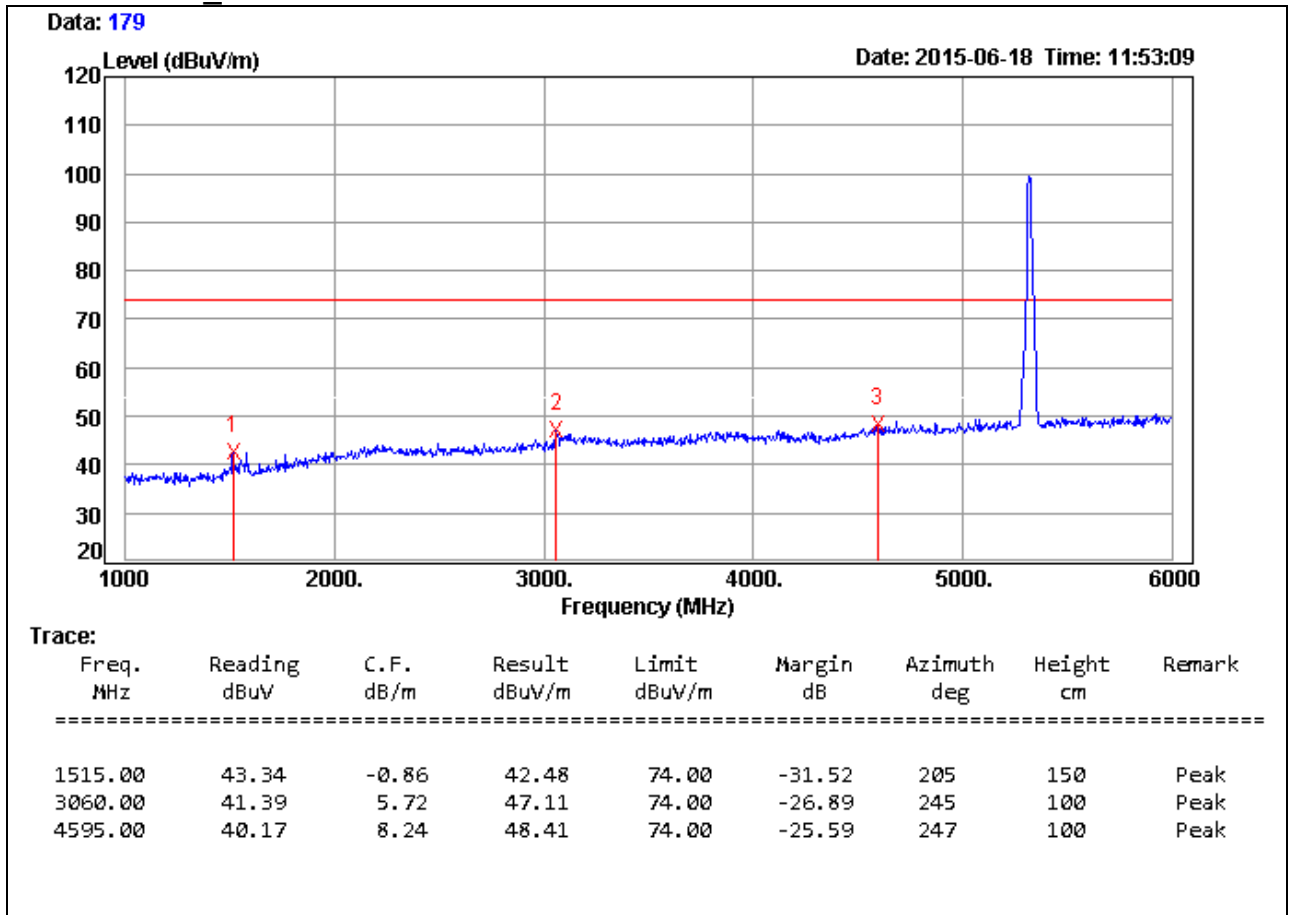

**Remark:**

1. Measuring frequencies from 1 GHz to the 10th harmonic of highest fundamental frequency.
2. Average test would be performed if the peak result were greater than the average limit.
3. Measurements above show only up to 6 maximum emissions noted, or would be lesser, with " N/A " remark, if no specific emissions from the EUT are recorded (ie: margin>20dB from the applicable limit) and considered that's already beyond the background noise floor.
4. Result = Reading + Correction Factor  
 Margin = Result - Limit  
 Remark Peak = Result(PK) - Limit(PK)  
 Remark AVG = Result(AV) - Limit(AV)

<b>Product Name</b>	Computer	<b>Test By</b>	Waternil Guan
<b>Test Model</b>	POC127	<b>Test Date</b>	2015/06/10
<b>Test Mode</b>	UNII Band 2A/ IEEE 802.11an HT20 TX / CH High	<b>Temp. &amp; Humidity</b>	26°C, 52%

966 Chamber\_C at 3Meter / Vertical

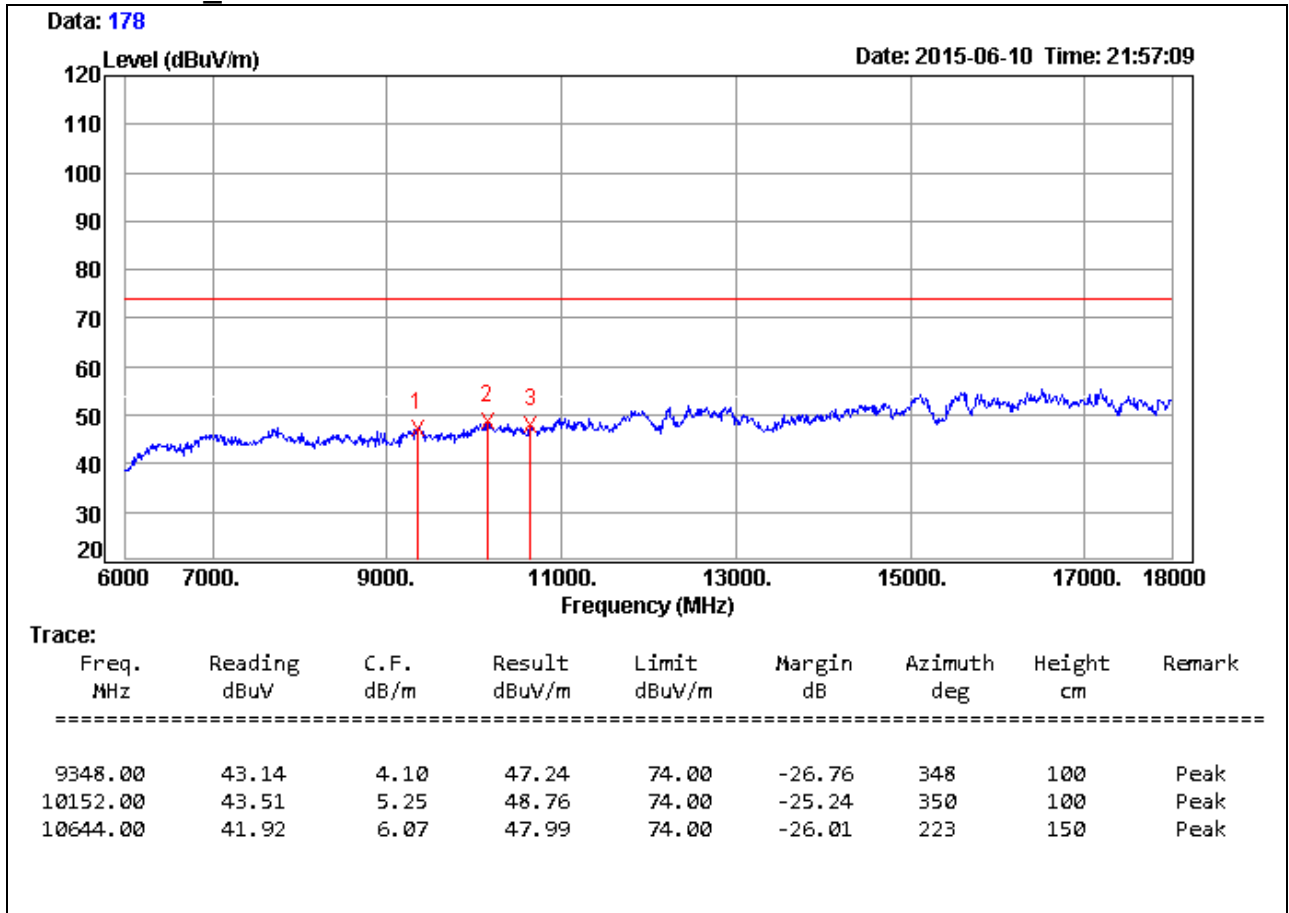

**Remark:**

1. Measuring frequencies from 1 GHz to the 10th harmonic of highest fundamental frequency.
2. Average test would be performed if the peak result were greater than the average limit.
3. Measurements above show only up to 6 maximum emissions noted, or would be lesser, with " N/A " remark, if no specific emissions from the EUT are recorded (ie: margin>20dB from the applicable limit) and considered that's already beyond the background noise floor.
4. Result = Reading + Correction Factor  
 Margin = Result – Limit  
 Remark Peak = Result(PK) – Limit(PK)  
 Remark AVG = Result(AV) – Limit(AV)
5. There is no emission in 18GHz ~ 40GHz.

<b>Product Name</b>	Computer	<b>Test By</b>	Waternil Guan
<b>Test Model</b>	POC127	<b>Test Date</b>	2015/06/22
<b>Test Mode</b>	UNII Band 2A/ IEEE 802.11an HT40 TX / CH Low	<b>Temp. &amp; Humidity</b>	26°C, 52%

966 Chamber\_C at 3Meter / Horizontal

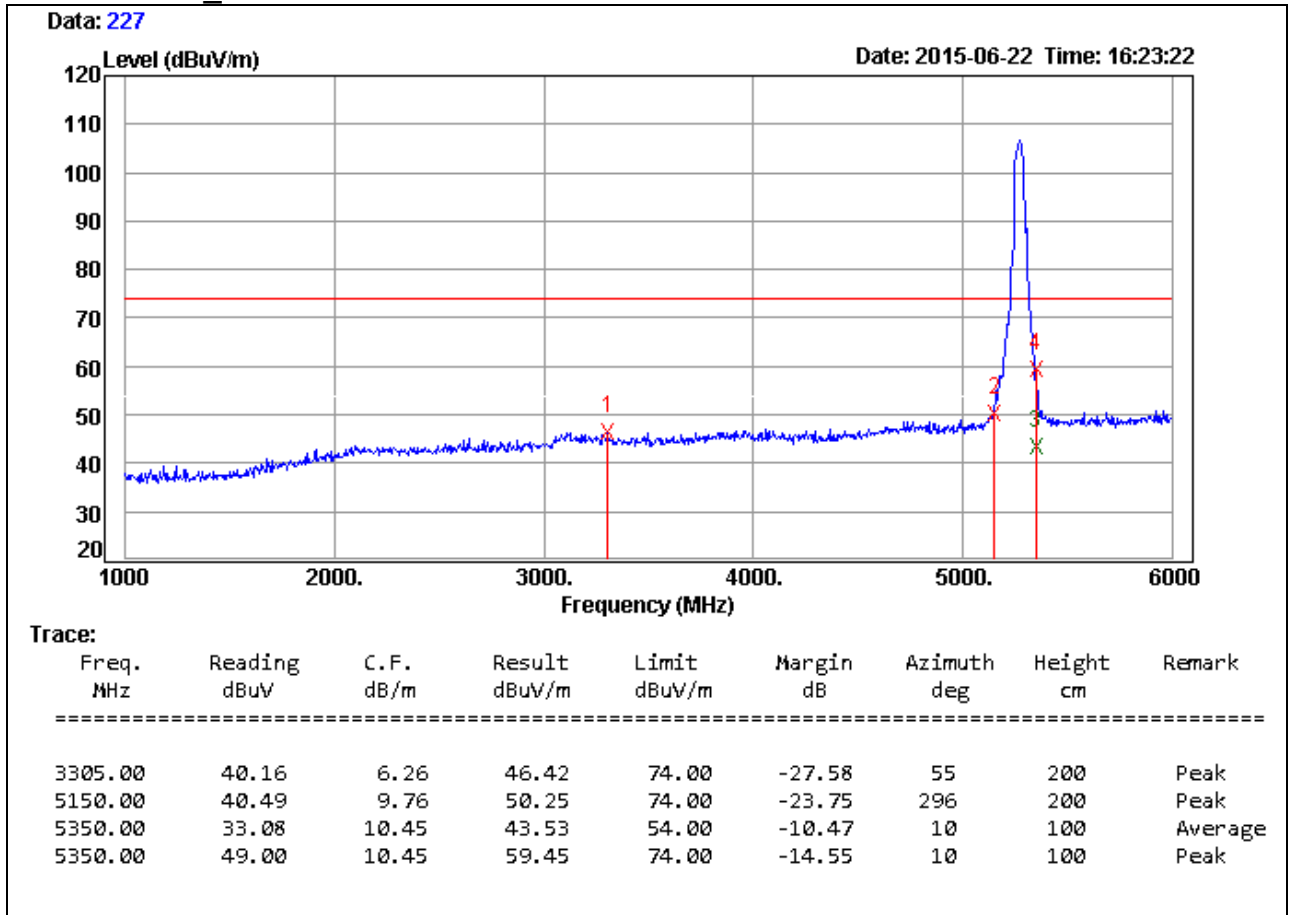

**Remark:**

1. Measuring frequencies from 1 GHz to the 10th harmonic of highest fundamental frequency.
2. Average test would be performed if the peak result were greater than the average limit.
3. Measurements above show only up to 6 maximum emissions noted, or would be lesser, with " N/A " remark, if no specific emissions from the EUT are recorded (ie: margin>20dB from the applicable limit) and considered that's already beyond the background noise floor.
4. Result = Reading + Correction Factor  
 Margin = Result - Limit  
 Remark Peak = Result(PK) - Limit(PK)  
 Remark AVG = Result(AV) - Limit(AV)



<b>Product Name</b>	Computer	<b>Test By</b>	Watnail Guan
<b>Test Model</b>	POC127	<b>Test Date</b>	2015/06/18
<b>Test Mode</b>	UNII Band 2A/ IEEE 802.11an HT40 TX / CH Low	<b>Temp. &amp; Humidity</b>	26°C, 52%

966 Chamber\_C at 3Meter / Horizontal

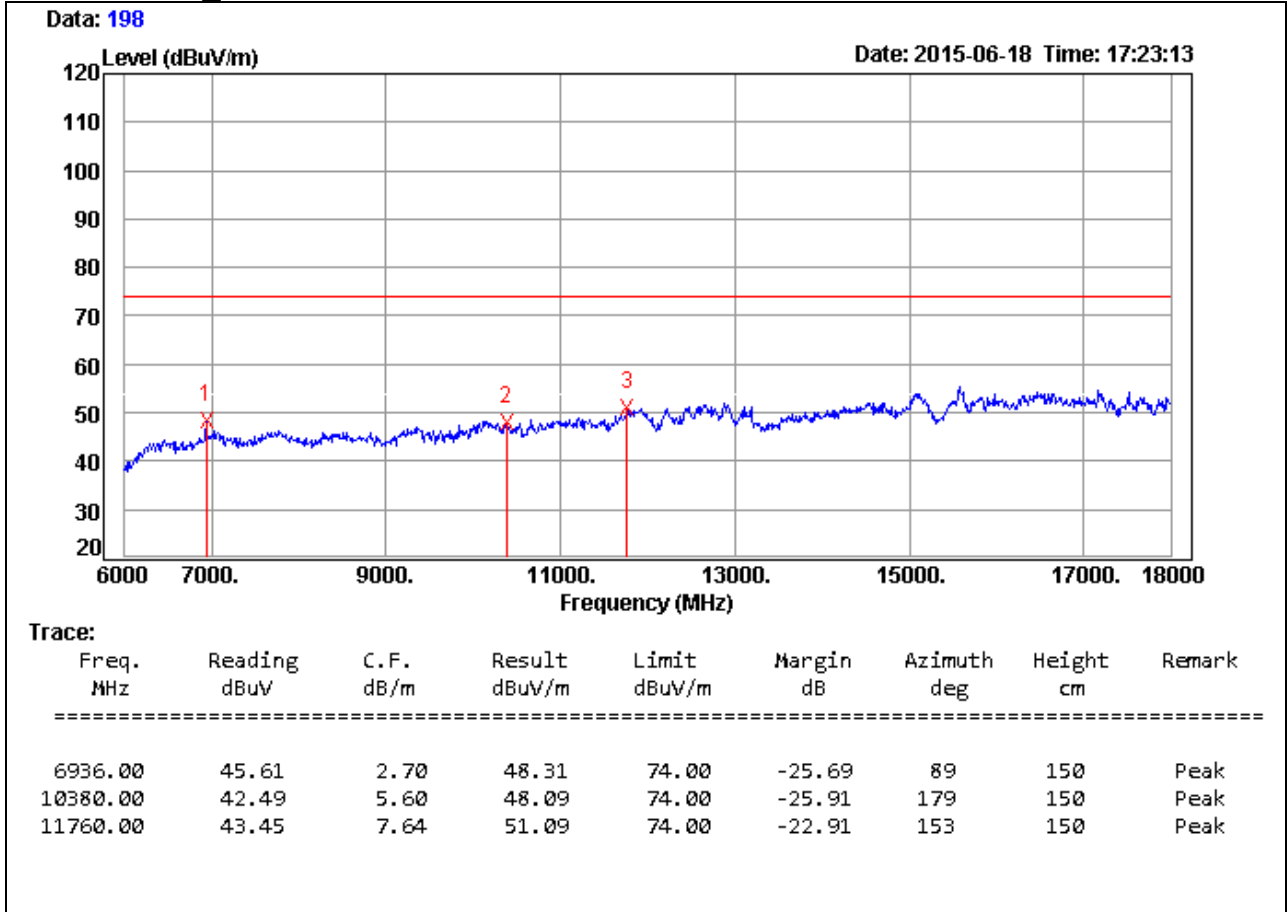

**Remark:**

1. Measuring frequencies from 1 GHz to the 10th harmonic of highest fundamental frequency.
2. Average test would be performed if the peak result were greater than the average limit.
3. Measurements above show only up to 6 maximum emissions noted, or would be lesser, with " N/A " remark, if no specific emissions from the EUT are recorded (ie: margin>20dB from the applicable limit) and considered that's already beyond the background noise floor.
4. Result = Reading + Correction Factor  
Margin = Result - Limit  
Remark Peak = Result(PK) - Limit(PK)  
Remark AVG = Result(AV) - Limit(AV)
5. There is no emission in 18GHz ~ 40GHz.

<b>Product Name</b>	Computer	<b>Test By</b>	Waternil Guan
<b>Test Model</b>	POC127	<b>Test Date</b>	2014/06/22
<b>Test Mode</b>	UNII Band 2A/ IEEE 802.11an HT40 TX / CH Low	<b>Temp. &amp; Humidity</b>	26°C, 52%

966 Chamber\_C at 3Meter / Vertical

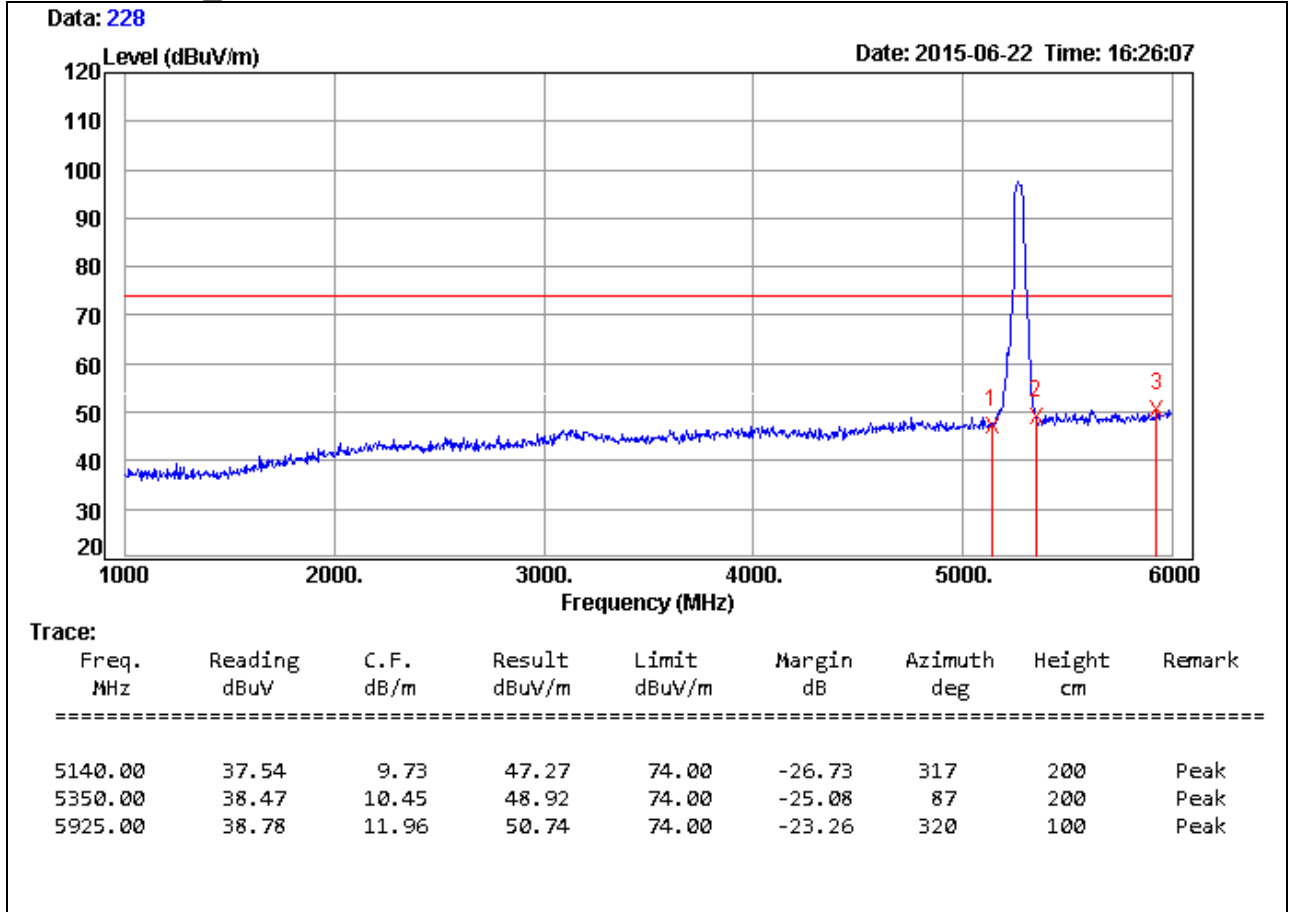

**Remark:**

1. Measuring frequencies from 1 GHz to the 10th harmonic of highest fundamental frequency.
2. Average test would be performed if the peak result were greater than the average limit.
3. Measurements above show only up to 6 maximum emissions noted, or would be lesser, with " N/A " remark, if no specific emissions from the EUT are recorded (ie: margin>20dB from the applicable limit) and considered that's already beyond the background noise floor.
4. Result = Reading + Correction Factor  
 Margin = Result - Limit  
 Remark Peak = Result(PK) - Limit(PK)  
 Remark AVG = Result(AV) - Limit(AV)

<b>Product Name</b>	Computer	<b>Test By</b>	Waternil Guan
<b>Test Model</b>	POC127	<b>Test Date</b>	2015/06/18
<b>Test Mode</b>	UNII Band 2A/ IEEE 802.11an HT40 TX / CH Low	<b>Temp. &amp; Humidity</b>	26°C, 52%

966 Chamber\_C at 3Meter / Vertical

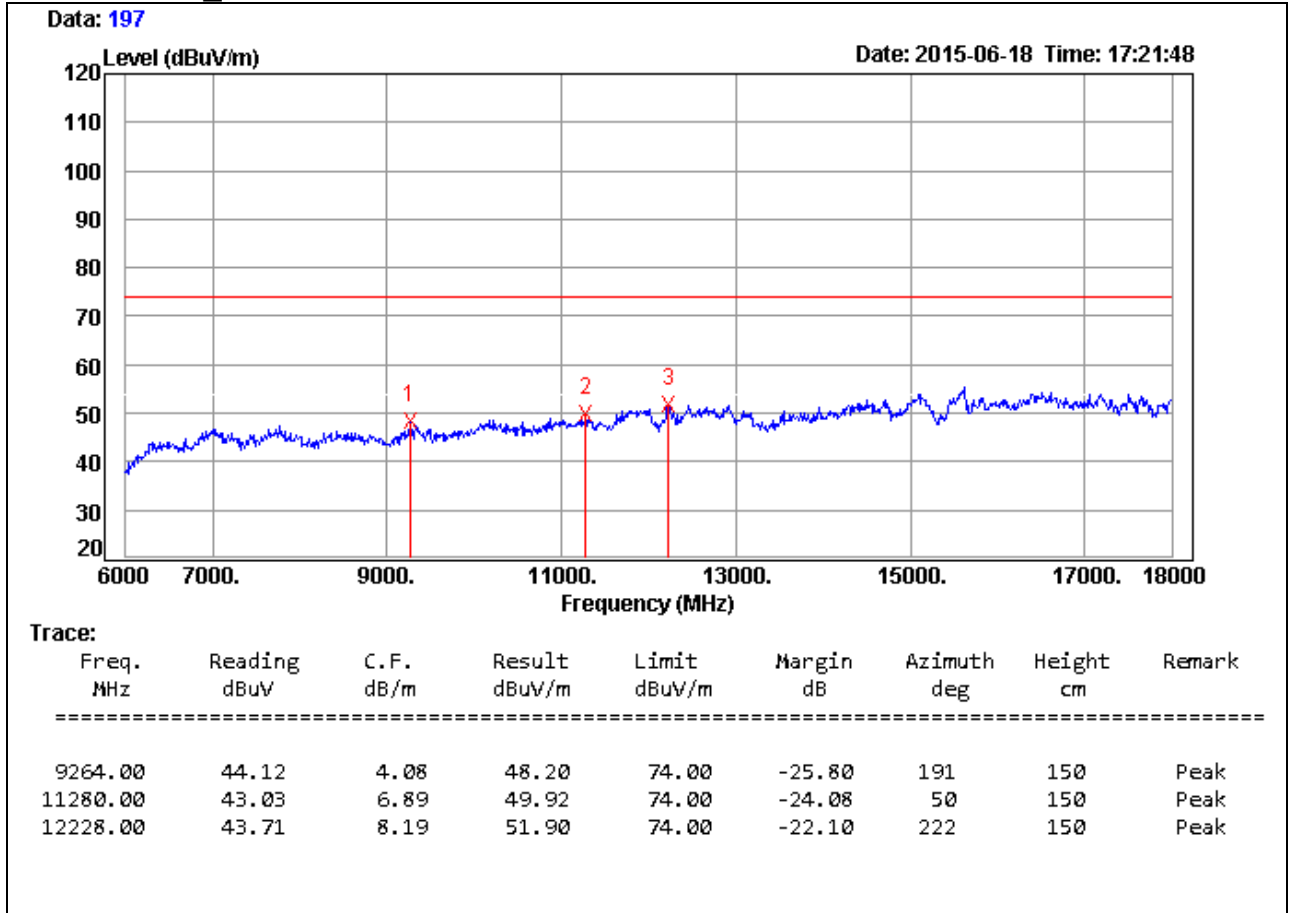

**Remark:**

1. Measuring frequencies from 1 GHz to the 10th harmonic of highest fundamental frequency.
2. Average test would be performed if the peak result were greater than the average limit.
3. Measurements above show only up to 6 maximum emissions noted, or would be lesser, with " N/A " remark, if no specific emissions from the EUT are recorded (ie: margin>20dB from the applicable limit) and considered that's already beyond the background noise floor.
4.  $Result = Reading + Correction\ Factor$   
 $Margin = Result - Limit$   
 $Remark\ Peak = Result(PK) - Limit(PK)$   
 $Remark\ AVG = Result(AV) - Limit(AV)$
5. There is no emission in 18GHz ~ 40GHz.

<b>Product Name</b>	Computer	<b>Test By</b>	Waternil Guan
<b>Test Model</b>	POC127	<b>Test Date</b>	2015/06/22
<b>Test Mode</b>	UNII Band 2A/ IEEE 802.11an HT40 TX / CH High	<b>Temp. &amp; Humidity</b>	26°C, 52%

966 Chamber\_C at 3Meter / Horizontal

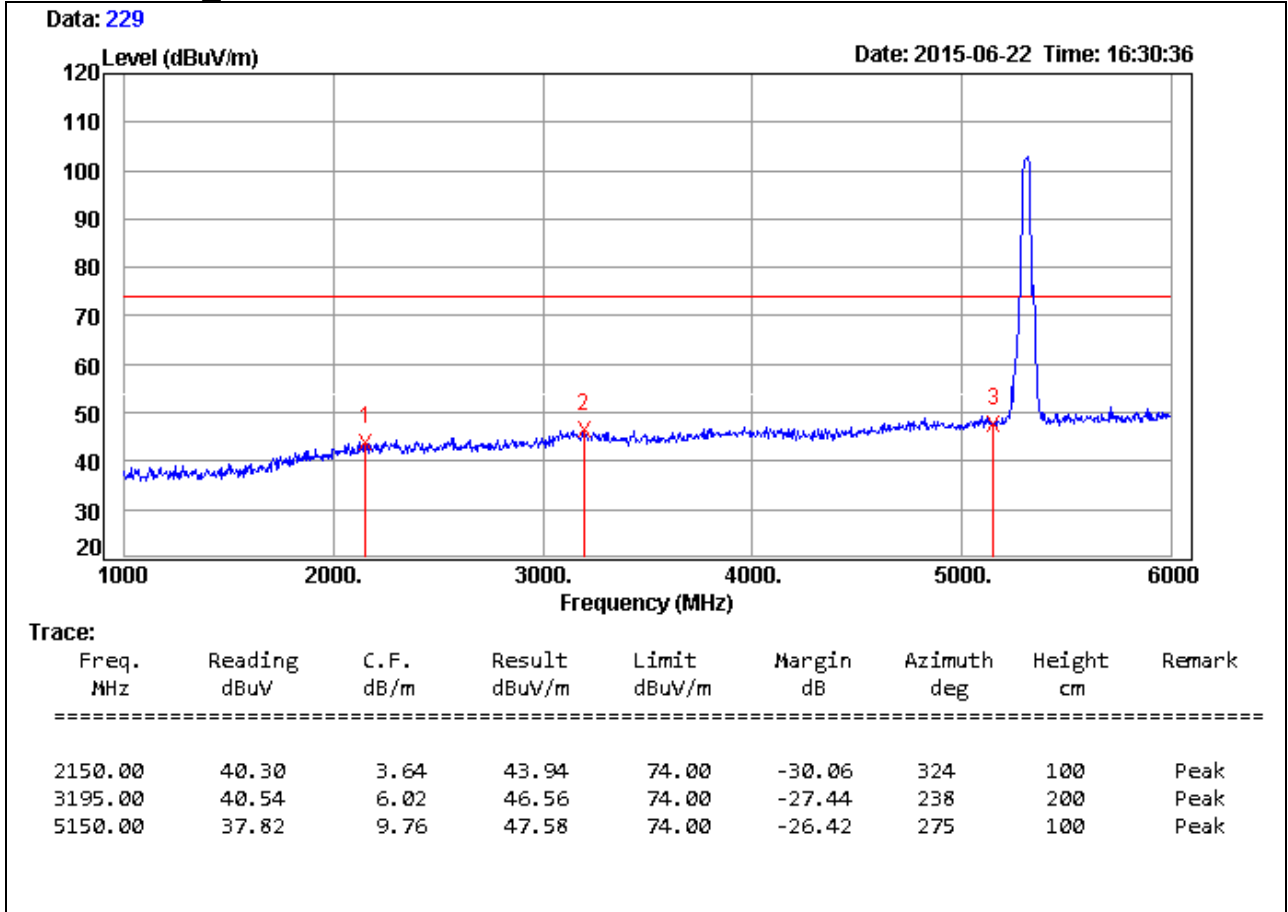

**Remark:**

1. Measuring frequencies from 1 GHz to the 10th harmonic of highest fundamental frequency.
2. Average test would be performed if the peak result were greater than the average limit.
3. Measurements above show only up to 6 maximum emissions noted, or would be lesser, with " N/A " remark, if no specific emissions from the EUT are recorded (ie: margin>20dB from the applicable limit) and considered that's already beyond the background noise floor.
4.  $Result = Reading + Correction\ Factor$   
 $Margin = Result - Limit$   
 $Remark\ Peak = Result(PK) - Limit(PK)$   
 $Remark\ AVG = Result(AV) - Limit(AV)$

<b>Product Name</b>	Computer	<b>Test By</b>	Waternil Guan
<b>Test Model</b>	POC127	<b>Test Date</b>	2015/06/18
<b>Test Mode</b>	UNII Band 2A/ IEEE 802.11an HT40 TX / CH High	<b>Temp. &amp; Humidity</b>	26°C, 52%

966 Chamber\_C at 3Meter / Horizontal

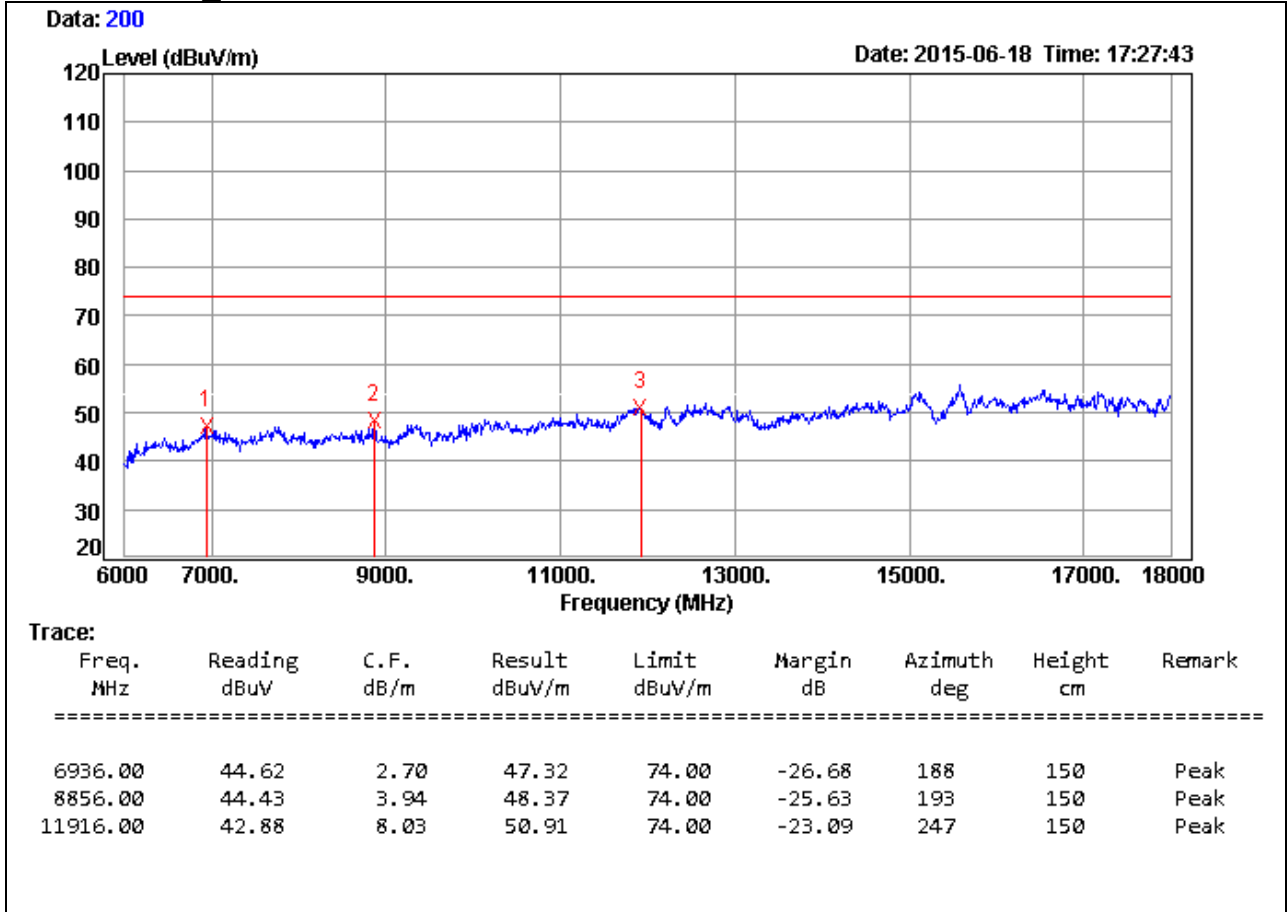

**Remark:**

1. Measuring frequencies from 1 GHz to the 10th harmonic of highest fundamental frequency.
2. Average test would be performed if the peak result were greater than the average limit.
3. Measurements above show only up to 6 maximum emissions noted, or would be lesser, with " N/A " remark, if no specific emissions from the EUT are recorded (ie: margin>20dB from the applicable limit) and considered that's already beyond the background noise floor.
4. Result = Reading + Correction Factor  
Margin = Result - Limit  
Remark Peak = Result(PK) - Limit(PK)  
Remark AVG = Result(AV) - Limit(AV)
5. There is no emission in 18GHz ~ 40GHz.

<b>Product Name</b>	Computer	<b>Test By</b>	Waternil Guan
<b>Test Model</b>	POC127	<b>Test Date</b>	2015/06/22
<b>Test Mode</b>	UNII Band 2A/ IEEE 802.11an HT40 TX / CH High	<b>Temp. &amp; Humidity</b>	26°C, 52%

966 Chamber\_C at 3Meter / Vertical

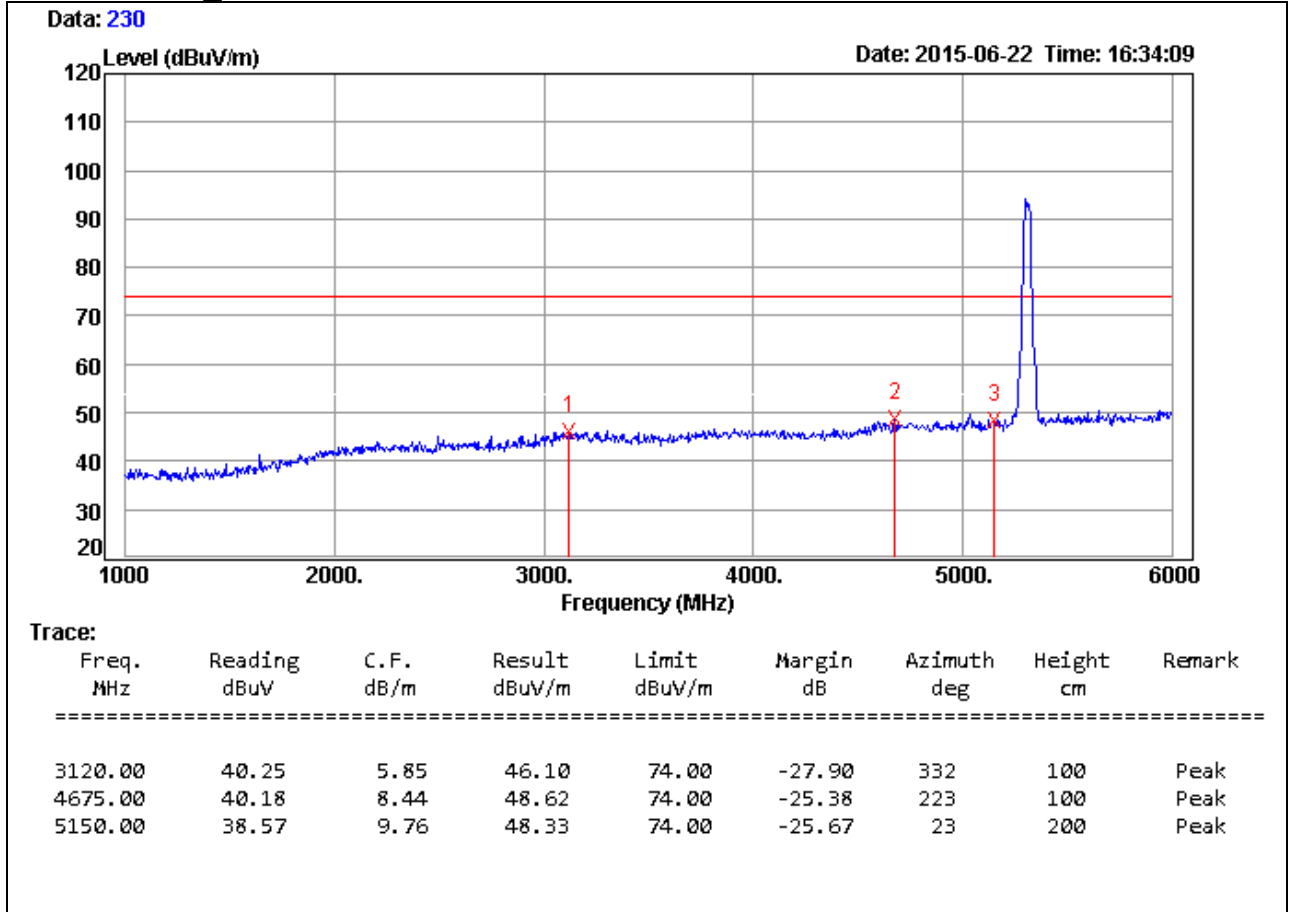

**Remark:**

1. Measuring frequencies from 1 GHz to the 10th harmonic of highest fundamental frequency.
2. Average test would be performed if the peak result were greater than the average limit.
3. Measurements above show only up to 6 maximum emissions noted, or would be lesser, with " N/A " remark, if no specific emissions from the EUT are recorded (ie: margin>20dB from the applicable limit) and considered that's already beyond the background noise floor.
4.  $Result = Reading + Correction\ Factor$   
 $Margin = Result - Limit$   
 $Remark\ Peak = Result(PK) - Limit(PK)$   
 $Remark\ AVG = Result(AV) - Limit(AV)$

<b>Product Name</b>	Computer	<b>Test By</b>	Waternil Guan
<b>Test Model</b>	POC127	<b>Test Date</b>	2015/06/18
<b>Test Mode</b>	UNII Band 2A/ IEEE 802.11an HT40 TX / CH High	<b>Temp. &amp; Humidity</b>	26°C, 52%

966 Chamber\_C at 3Meter / Vertical

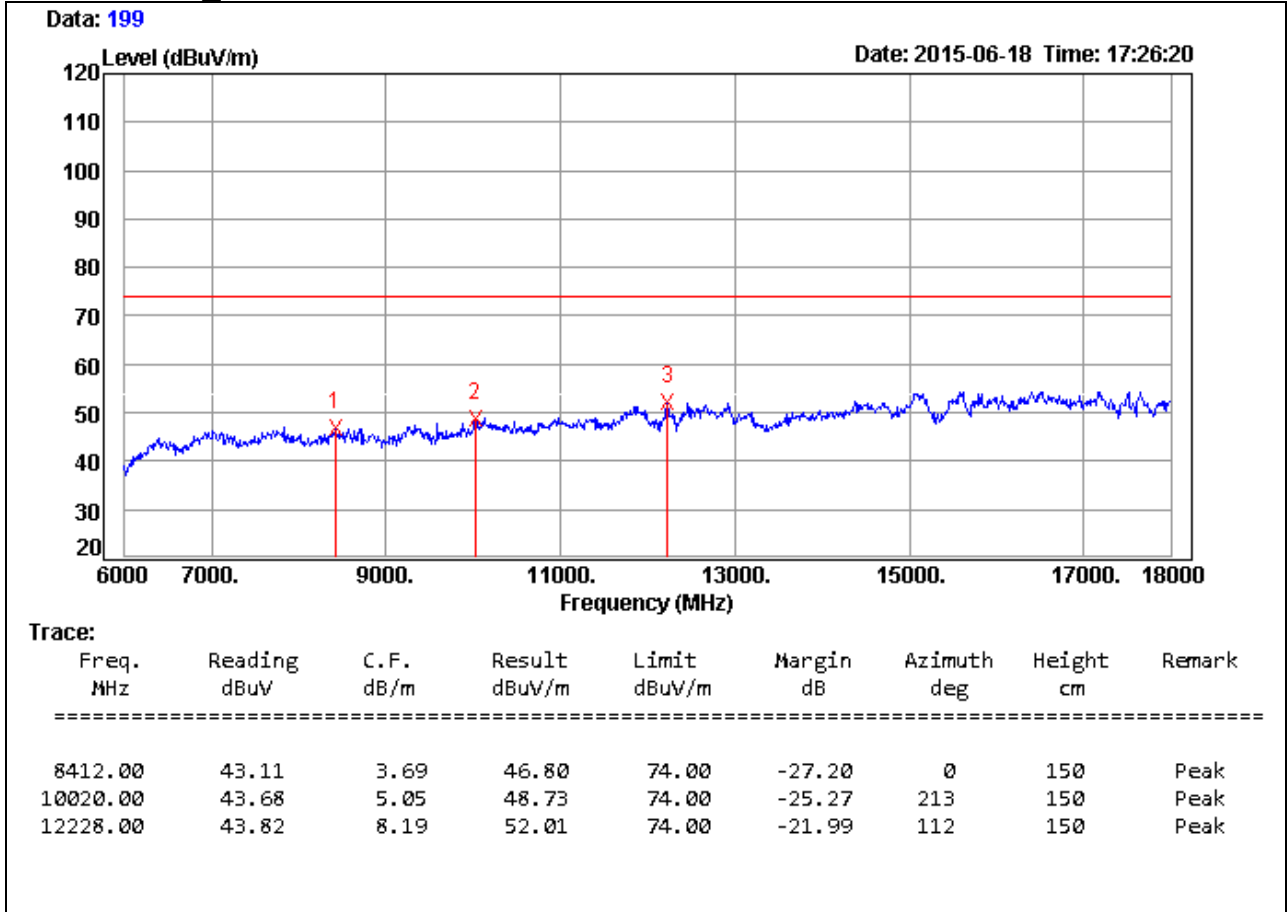

**Remark:**

1. Measuring frequencies from 1 GHz to the 10th harmonic of highest fundamental frequency.
2. Average test would be performed if the peak result were greater than the average limit.
3. Measurements above show only up to 6 maximum emissions noted, or would be lesser, with " N/A " remark, if no specific emissions from the EUT are recorded (ie: margin>20dB from the applicable limit) and considered that's already beyond the background noise floor.
4. Result = Reading + Correction Factor  
Margin = Result - Limit  
Remark Peak = Result(PK) - Limit(PK)  
Remark AVG = Result(AV) - Limit(AV)
5. There is no emission in 18GHz ~ 40GHz.

<b>Product Name</b>	Computer	<b>Test By</b>	Waternil Guan
<b>Test Model</b>	POC127	<b>Test Date</b>	2015/06/05
<b>Test Mode</b>	UNII Band 2C/ IEEE 802.11a TX / CH Low	<b>Temp. &amp; Humidity</b>	26°C, 52%

966 Chamber\_C at 3Meter / Horizontal

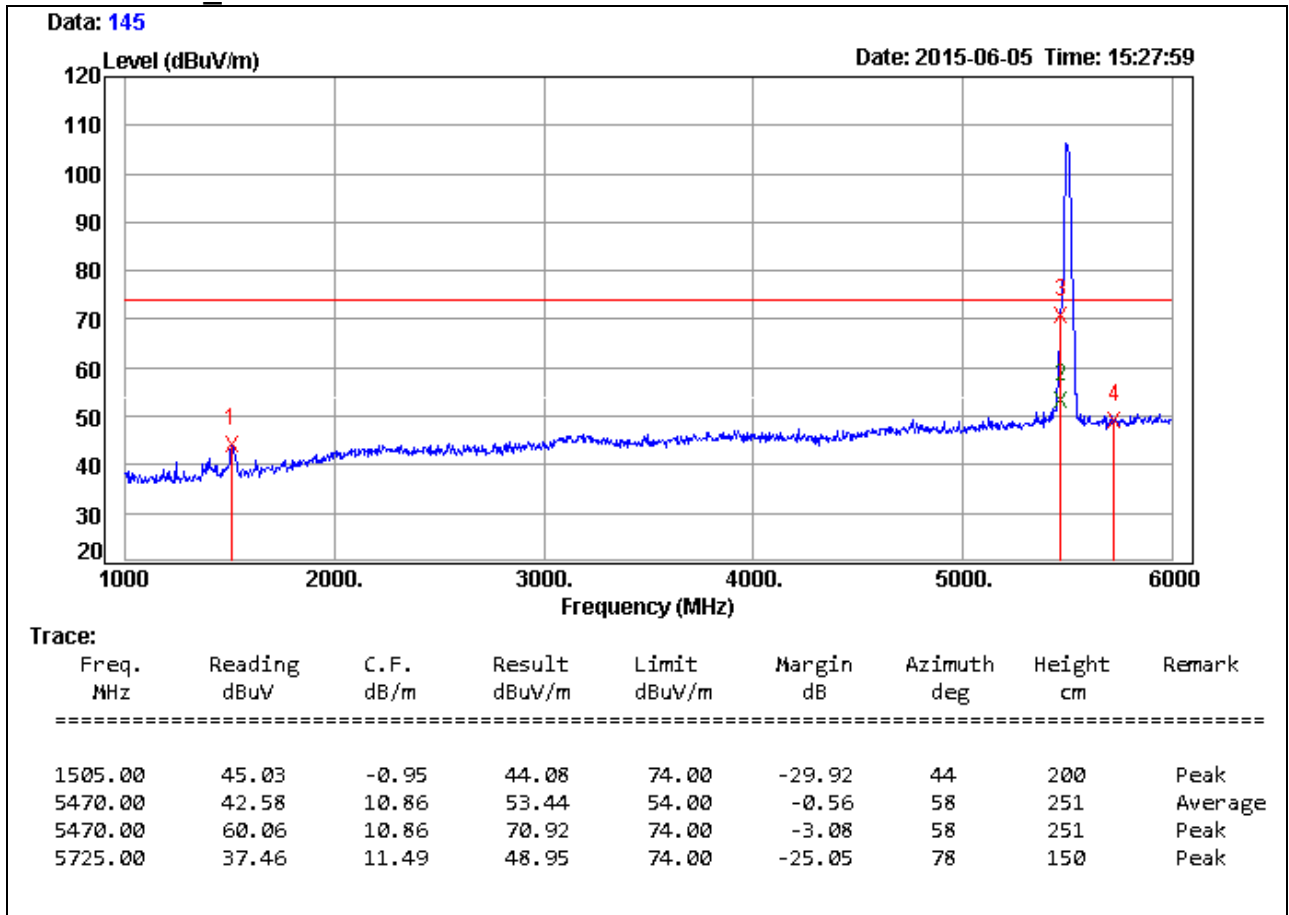

**Remark:**

1. Measuring frequencies from 1 GHz to the 10th harmonic of highest fundamental frequency.
2. Average test would be performed if the peak result were greater than the average limit.
3. Measurements above show only up to 6 maximum emissions noted, or would be lesser, with " N/A " remark, if no specific emissions from the EUT are recorded (ie: margin>20dB from the applicable limit) and considered that's already beyond the background noise floor.
4. Result = Reading + Correction Factor  
 Margin = Result - Limit  
 Remark Peak = Result(PK) - Limit(PK)  
 Remark AVG = Result(AV) - Limit(AV)



<b>Product Name</b>	Computer	<b>Test By</b>	Waternil Guan
<b>Test Model</b>	POC127	<b>Test Date</b>	2015/06/04
<b>Test Mode</b>	UNII Band 2C/ IEEE 802.11a TX / CH Low	<b>Temp. &amp; Humidity</b>	26°C, 52%

966 Chamber\_C at 3Meter / Horizontal

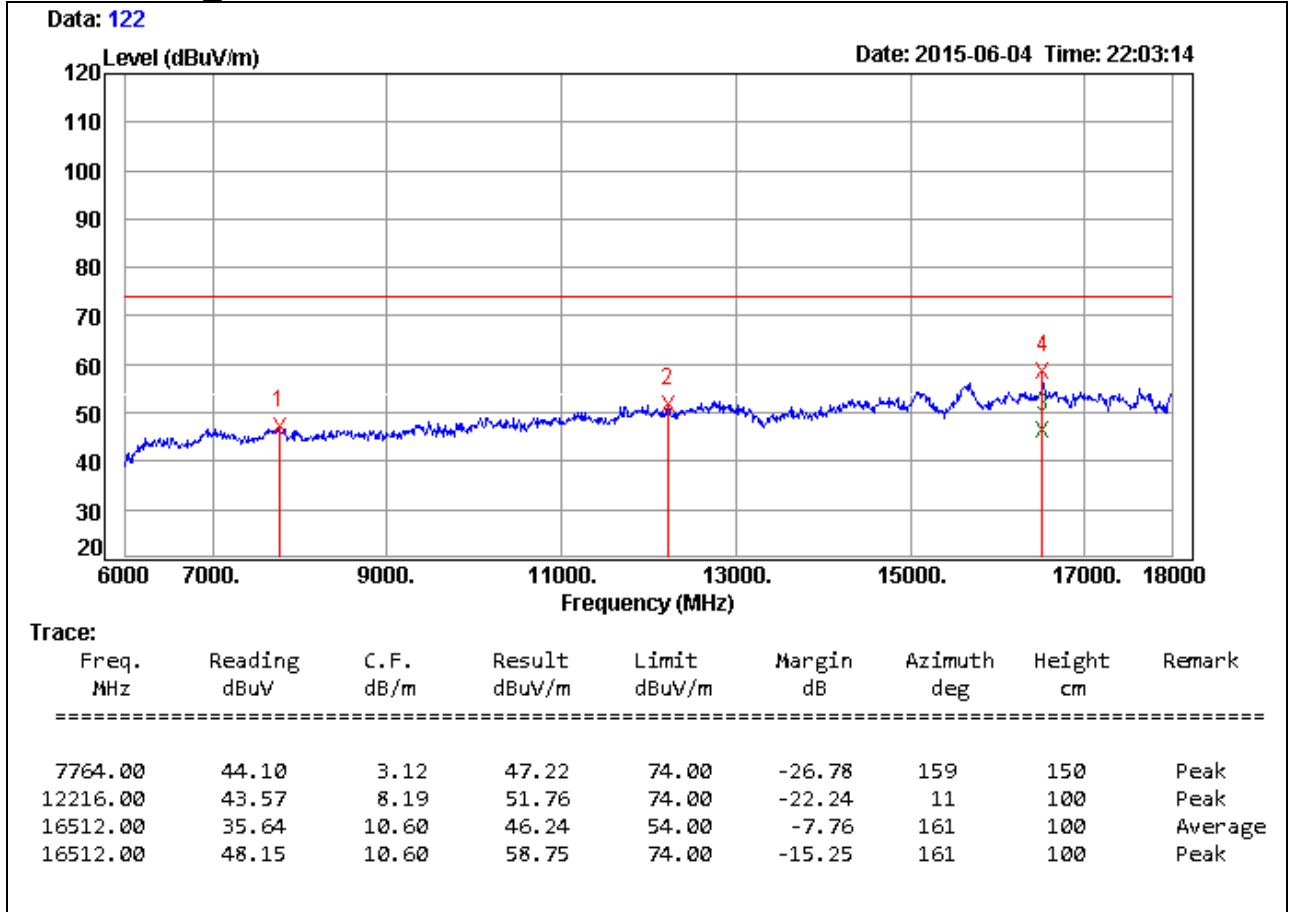

**Remark:**

1. Measuring frequencies from 1 GHz to the 10th harmonic of highest fundamental frequency.
2. Average test would be performed if the peak result were greater than the average limit.
3. Measurements above show only up to 6 maximum emissions noted, or would be lesser, with " N/A " remark, if no specific emissions from the EUT are recorded (ie: margin>20dB from the applicable limit) and considered that's already beyond the background noise floor.
4. Result = Reading + Correction Factor  
Margin = Result - Limit  
Remark Peak = Result(PK) - Limit(PK)  
Remark AVG = Result(AV) - Limit(AV)
5. There is no emission in 18GHz ~ 40GHz.

<b>Product Name</b>	Computer	<b>Test By</b>	Waternil Guan
<b>Test Model</b>	POC127	<b>Test Date</b>	2015/06/05
<b>Test Mode</b>	UNII Band 2C/ IEEE 802.11a TX / CH Low	<b>Temp. &amp; Humidity</b>	26°C, 52%

966 Chamber\_C at 3Meter / Vertical

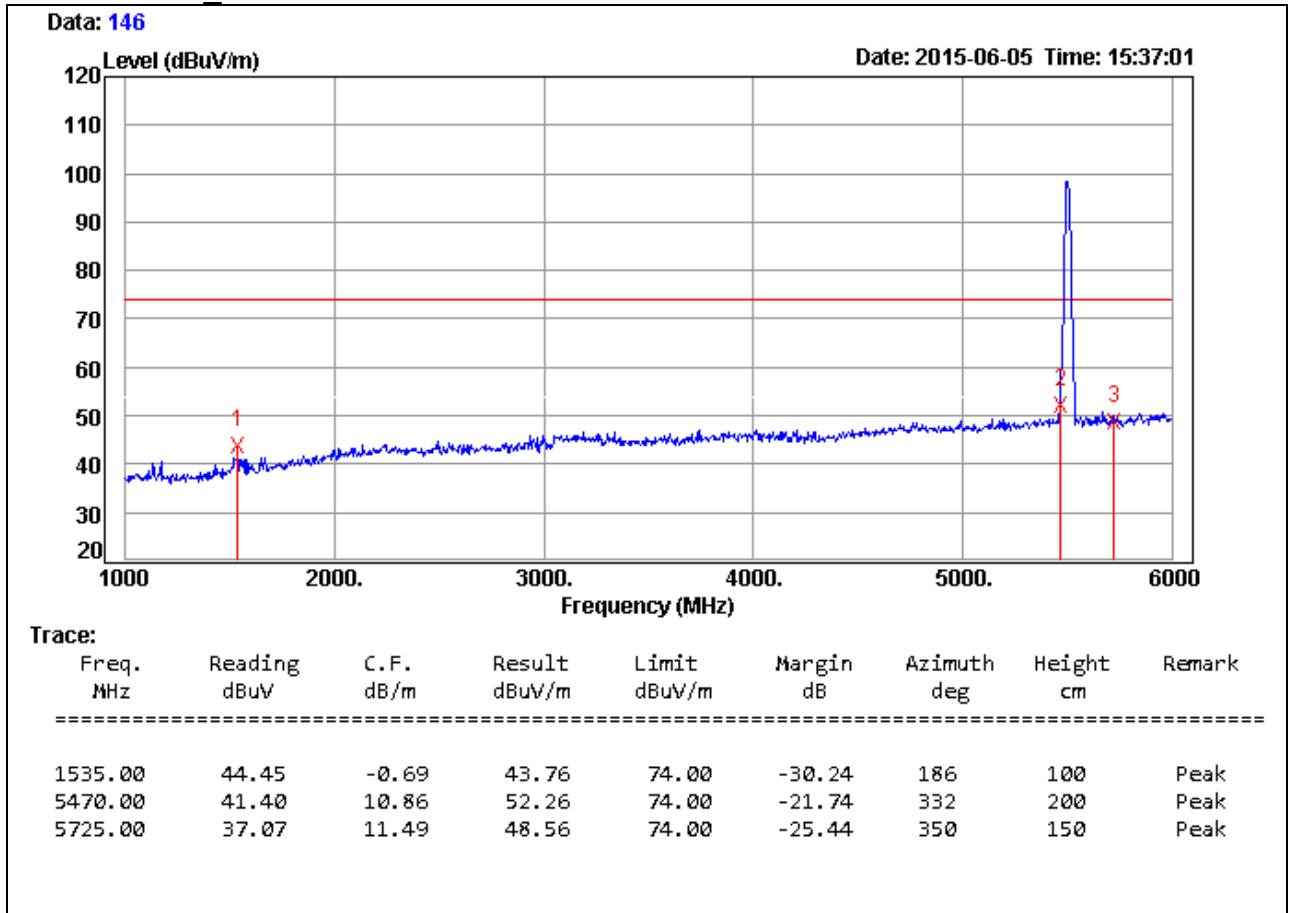

**Remark:**

1. Measuring frequencies from 1 GHz to the 10th harmonic of highest fundamental frequency.
2. Average test would be performed if the peak result were greater than the average limit.
3. Measurements above show only up to 6 maximum emissions noted, or would be lesser, with " N/A " remark, if no specific emissions from the EUT are recorded (ie: margin>20dB from the applicable limit) and considered that's already beyond the background noise floor.
4.  $Result = Reading + Correction\ Factor$   
 $Margin = Result - Limit$   
 $Remark\ Peak = Result(PK) - Limit(PK)$   
 $Remark\ AVG = Result(AV) - Limit(AV)$

<b>Product Name</b>	Computer	<b>Test By</b>	Watnail Guan
<b>Test Model</b>	POC127	<b>Test Date</b>	2015/06/04
<b>Test Mode</b>	UNII Band 2C/ IEEE 802.11a TX / CH Low	<b>Temp. &amp; Humidity</b>	26°C, 52%

966 Chamber\_C at 3Meter / Vertical

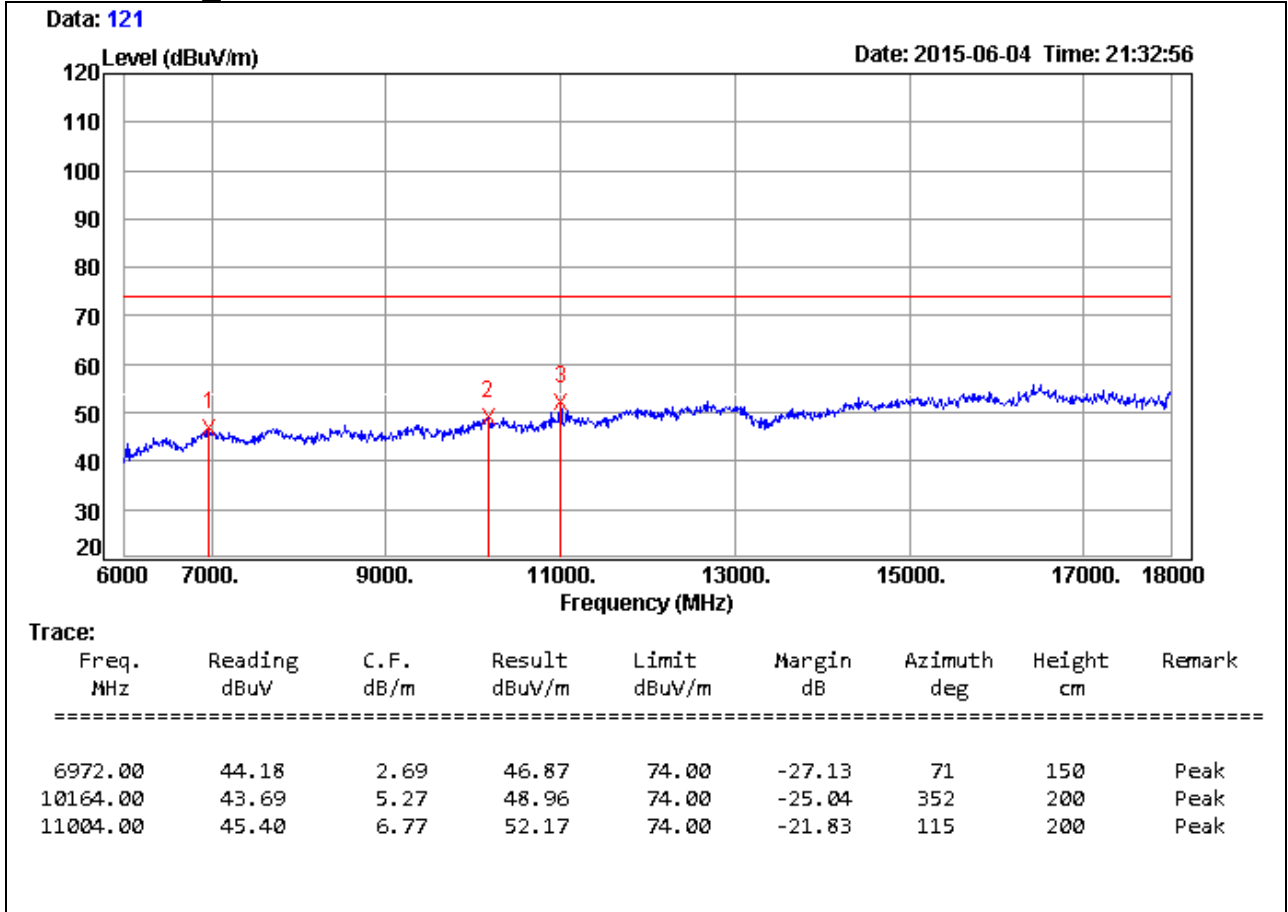

**Remark:**

1. Measuring frequencies from 1 GHz to the 10th harmonic of highest fundamental frequency.
2. Average test would be performed if the peak result were greater than the average limit.
3. Measurements above show only up to 6 maximum emissions noted, or would be lesser, with " N/A " remark, if no specific emissions from the EUT are recorded (ie: margin>20dB from the applicable limit) and considered that's already beyond the background noise floor.
4.  $Result = Reading + Correction\ Factor$   
 $Margin = Result - Limit$   
 $Remark\ Peak = Result(PK) - Limit(PK)$   
 $Remark\ AVG = Result(AV) - Limit(AV)$
5. There is no emission in 18GHz ~ 40GHz.

<b>Product Name</b>	Computer	<b>Test By</b>	Waternil Guan
<b>Test Model</b>	POC127	<b>Test Date</b>	2015/06/05
<b>Test Mode</b>	UNII Band 2C/ IEEE 802.11a TX / CH Middle	<b>Temp. &amp; Humidity</b>	26°C, 52%

966 Chamber\_C at 3Meter / Horizontal

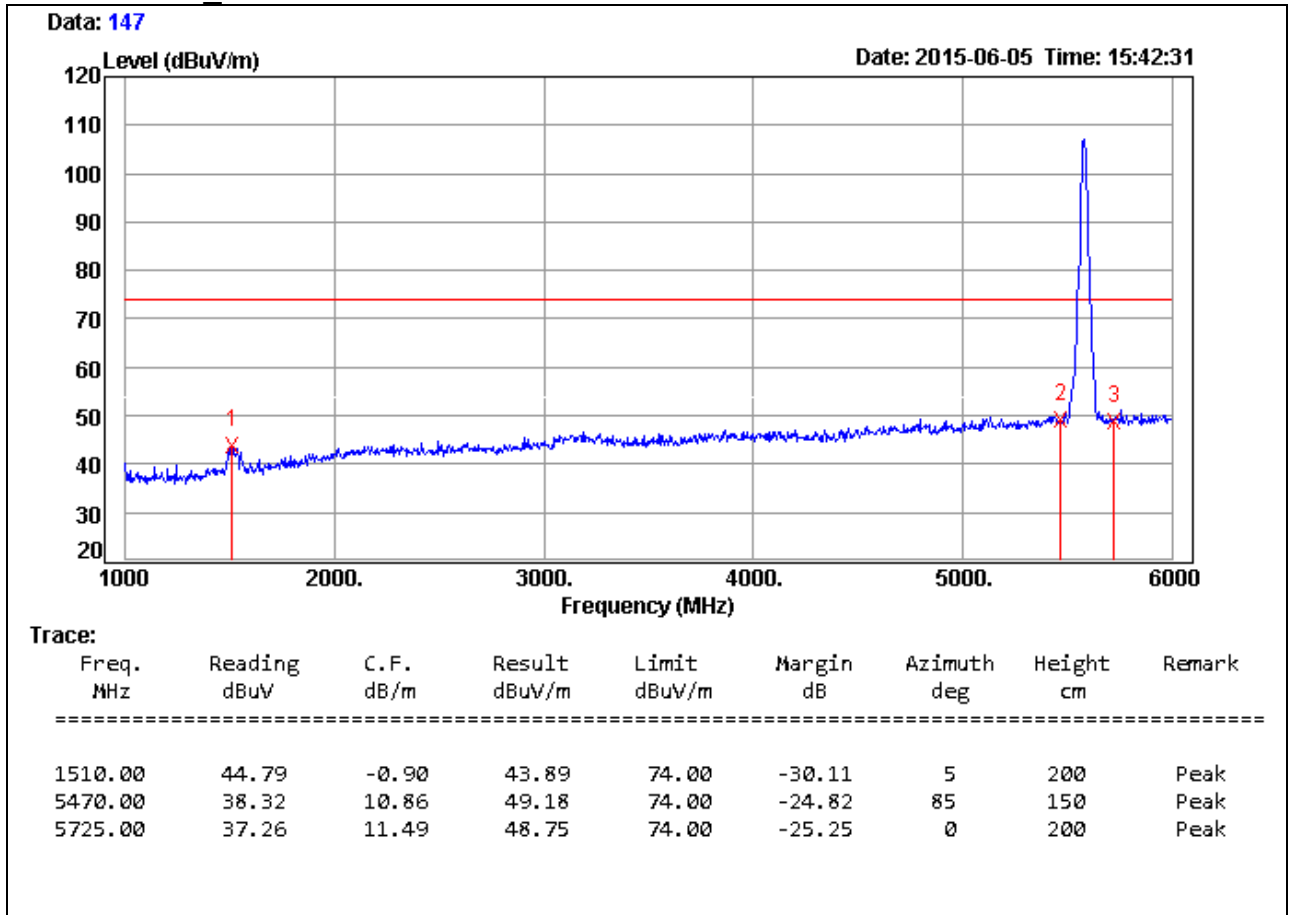

**Remark:**

1. Measuring frequencies from 1 GHz to the 10th harmonic of highest fundamental frequency.
2. Average test would be performed if the peak result were greater than the average limit.
3. Measurements above show only up to 6 maximum emissions noted, or would be lesser, with " N/A " remark, if no specific emissions from the EUT are recorded (ie: margin>20dB from the applicable limit) and considered that's already beyond the background noise floor.
4.  $Result = Reading + Correction\ Factor$   
 $Margin = Result - Limit$   
 $Remark\ Peak = Result(PK) - Limit(PK)$   
 $Remark\ AVG = Result(AV) - Limit(AV)$

<b>Product Name</b>	Computer	<b>Test By</b>	Waternil Guan
<b>Test Model</b>	POC127	<b>Test Date</b>	2015/06/04
<b>Test Mode</b>	UNII Band 2C/ IEEE 802.11a TX / CH Middle	<b>Temp. &amp; Humidity</b>	26°C, 52%

966 Chamber\_C at 3Meter / Horizontal

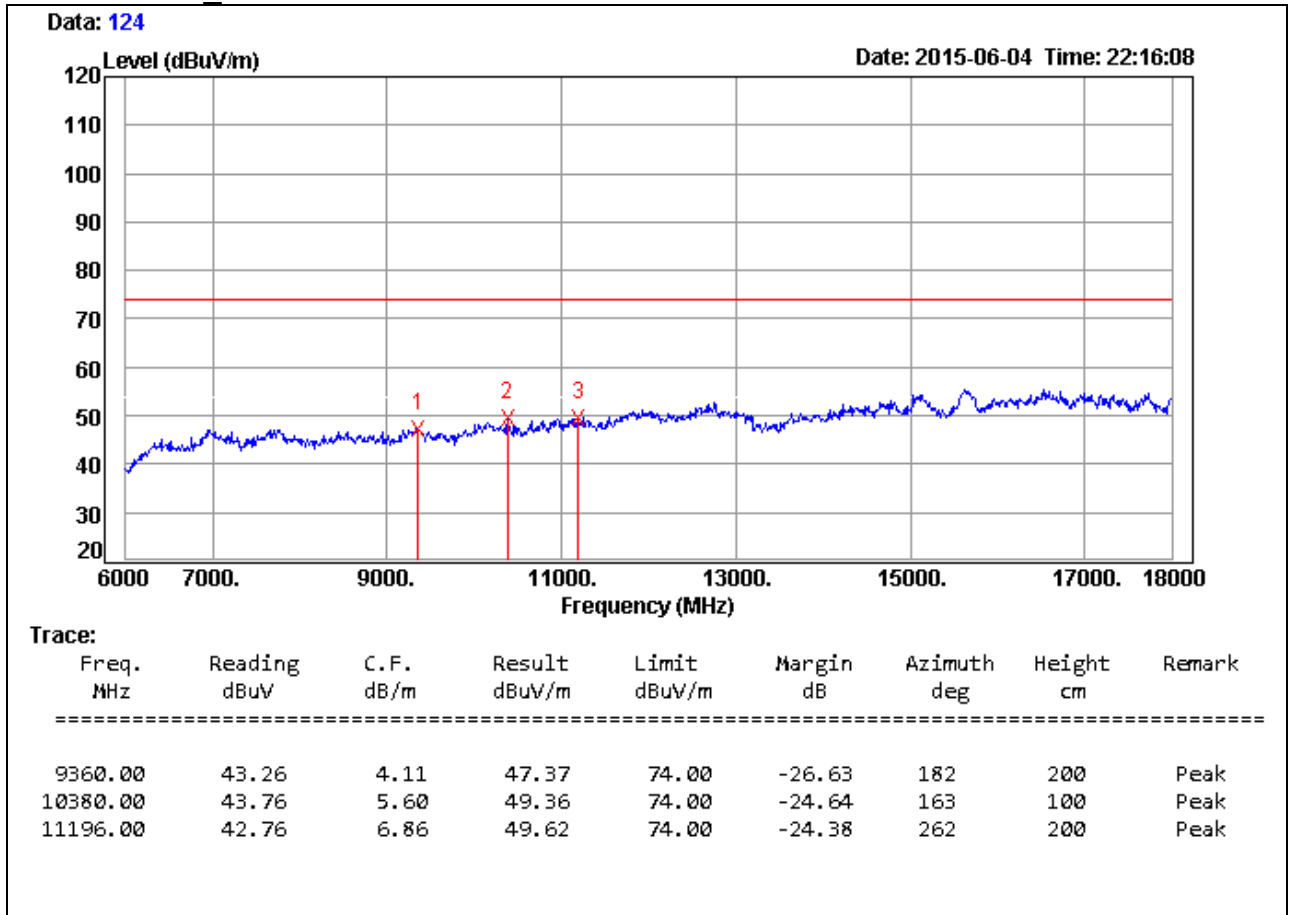

**Remark:**

1. Measuring frequencies from 1 GHz to the 10th harmonic of highest fundamental frequency.
2. Average test would be performed if the peak result were greater than the average limit.
3. Measurements above show only up to 6 maximum emissions noted, or would be lesser, with " N/A " remark, if no specific emissions from the EUT are recorded (ie: margin>20dB from the applicable limit) and considered that's already beyond the background noise floor.
4. Result = Reading + Correction Factor  
Margin = Result - Limit  
Remark Peak = Result(PK) - Limit(PK)  
Remark AVG = Result(AV) - Limit(AV)
5. There is no emission in 18GHz ~ 40GHz.

<b>Product Name</b>	Computer	<b>Test By</b>	Waternil Guan
<b>Test Model</b>	POC127	<b>Test Date</b>	2015/06/05
<b>Test Mode</b>	UNII Band 2C/ IEEE 802.11a TX / CH Middle	<b>Temp. &amp; Humidity</b>	26°C, 52%

966 Chamber\_C at 3Meter / Vertical

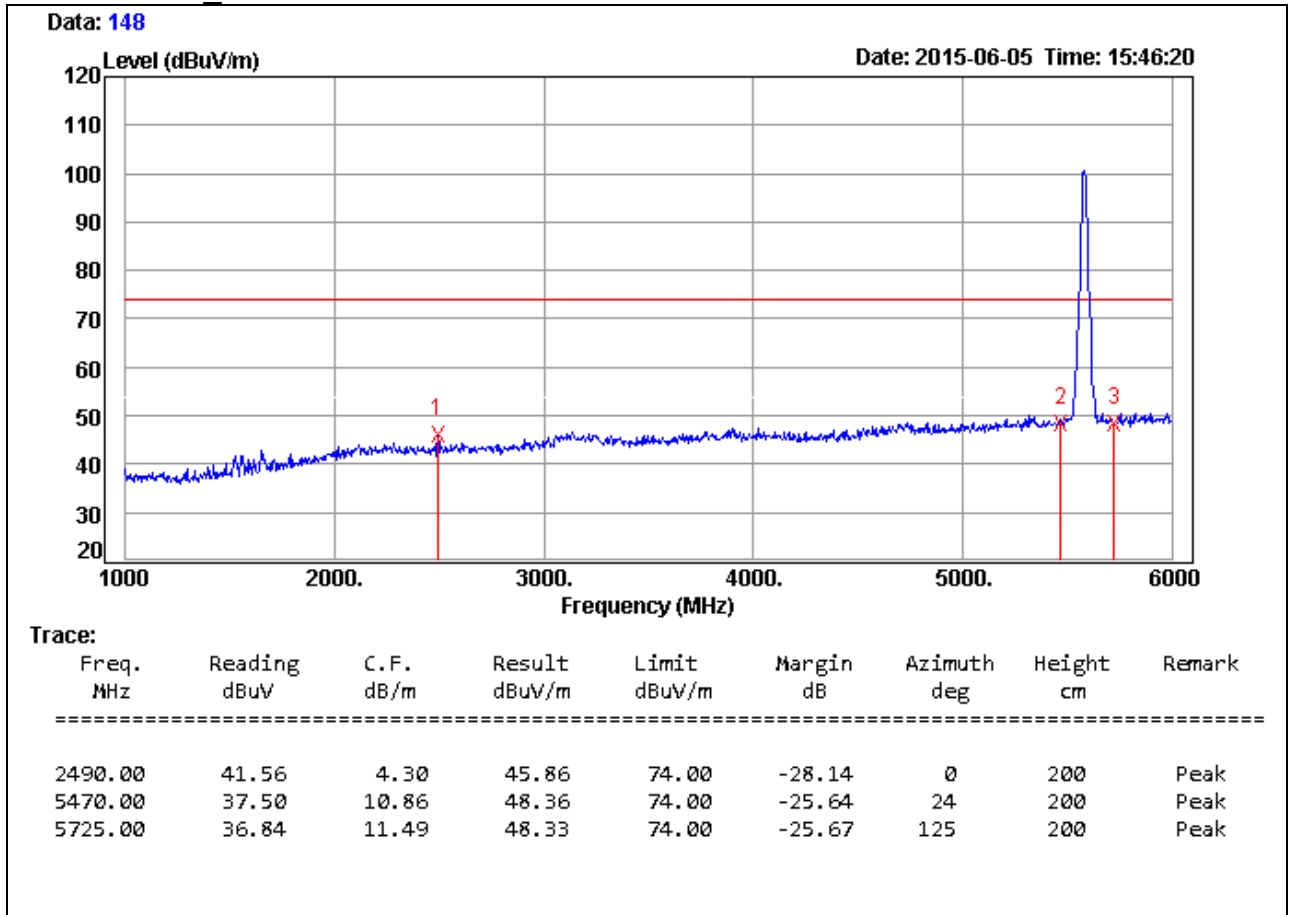

**Remark:**

1. Measuring frequencies from 1 GHz to the 10th harmonic of highest fundamental frequency.
2. Average test would be performed if the peak result were greater than the average limit.
3. Measurements above show only up to 6 maximum emissions noted, or would be lesser, with " N/A " remark, if no specific emissions from the EUT are recorded (ie: margin>20dB from the applicable limit) and considered that's already beyond the background noise floor.
4.  $Result = Reading + Correction\ Factor$   
 $Margin = Result - Limit$   
 $Remark\ Peak = Result(PK) - Limit(PK)$   
 $Remark\ AVG = Result(AV) - Limit(AV)$

<b>Product Name</b>	Computer	<b>Test By</b>	Waternil Guan
<b>Test Model</b>	POC127	<b>Test Date</b>	2015/06/04
<b>Test Mode</b>	UNII Band 2C/ IEEE 802.11a TX / CH Middle	<b>Temp. &amp; Humidity</b>	26°C, 52%

966 Chamber\_C at 3Meter / Vertical

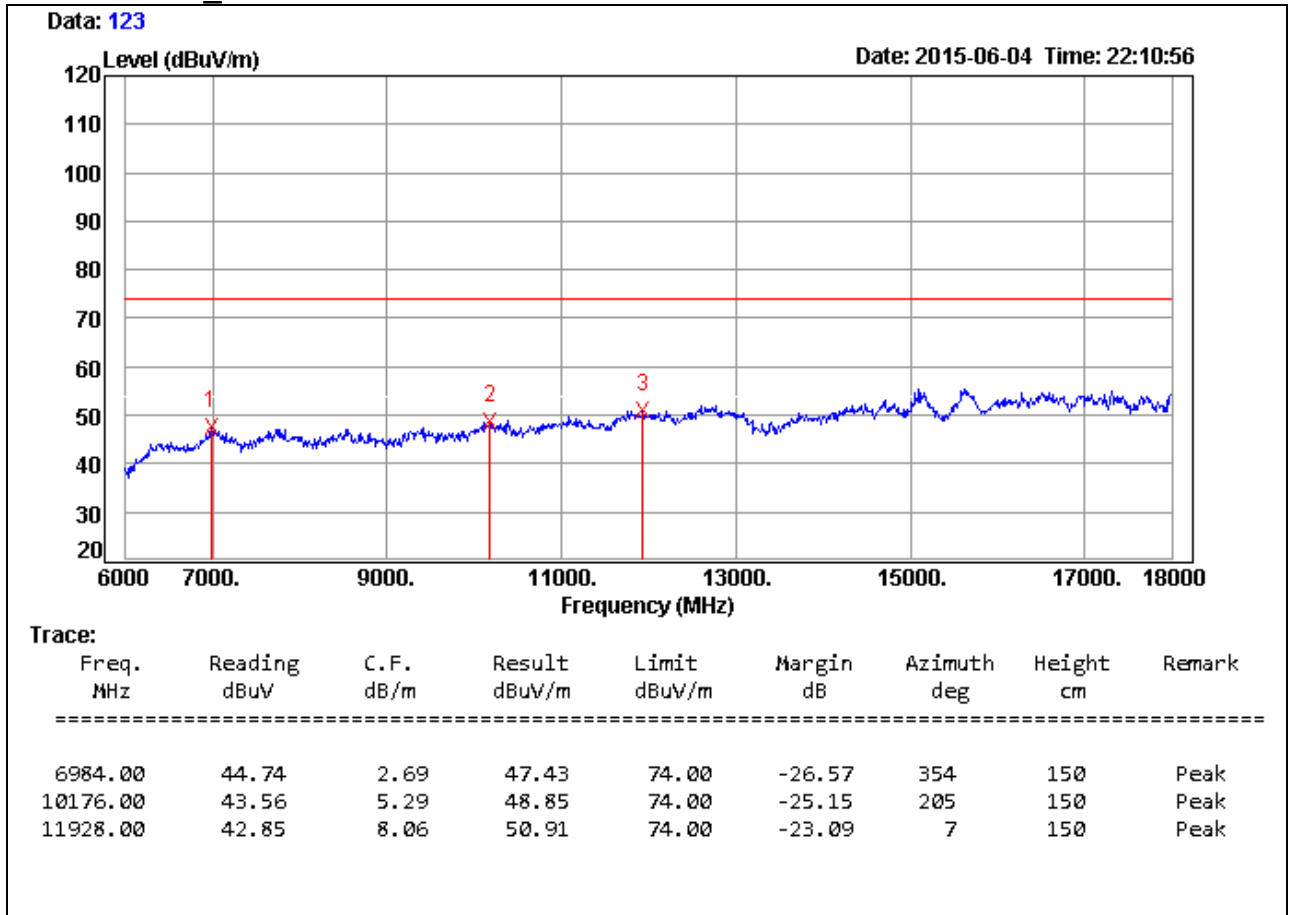

**Remark:**

1. Measuring frequencies from 1 GHz to the 10th harmonic of highest fundamental frequency.
2. Average test would be performed if the peak result were greater than the average limit.
3. Measurements above show only up to 6 maximum emissions noted, or would be lesser, with " N/A " remark, if no specific emissions from the EUT are recorded (ie: margin>20dB from the applicable limit) and considered that's already beyond the background noise floor.
4. Result = Reading + Correction Factor  
Margin = Result - Limit  
Remark Peak = Result(PK) - Limit(PK)  
Remark AVG = Result(AV) - Limit(AV)
5. There is no emission in 18GHz ~ 40GHz.

<b>Product Name</b>	Computer	<b>Test By</b>	Waternil Guan
<b>Test Model</b>	POC127	<b>Test Date</b>	2015/06/08
<b>Test Mode</b>	UNII Band 2C/ IEEE 802.11a TX / CH High	<b>Temp. &amp; Humidity</b>	26°C, 52%

966 Chamber\_C at 3Meter / Horizontal

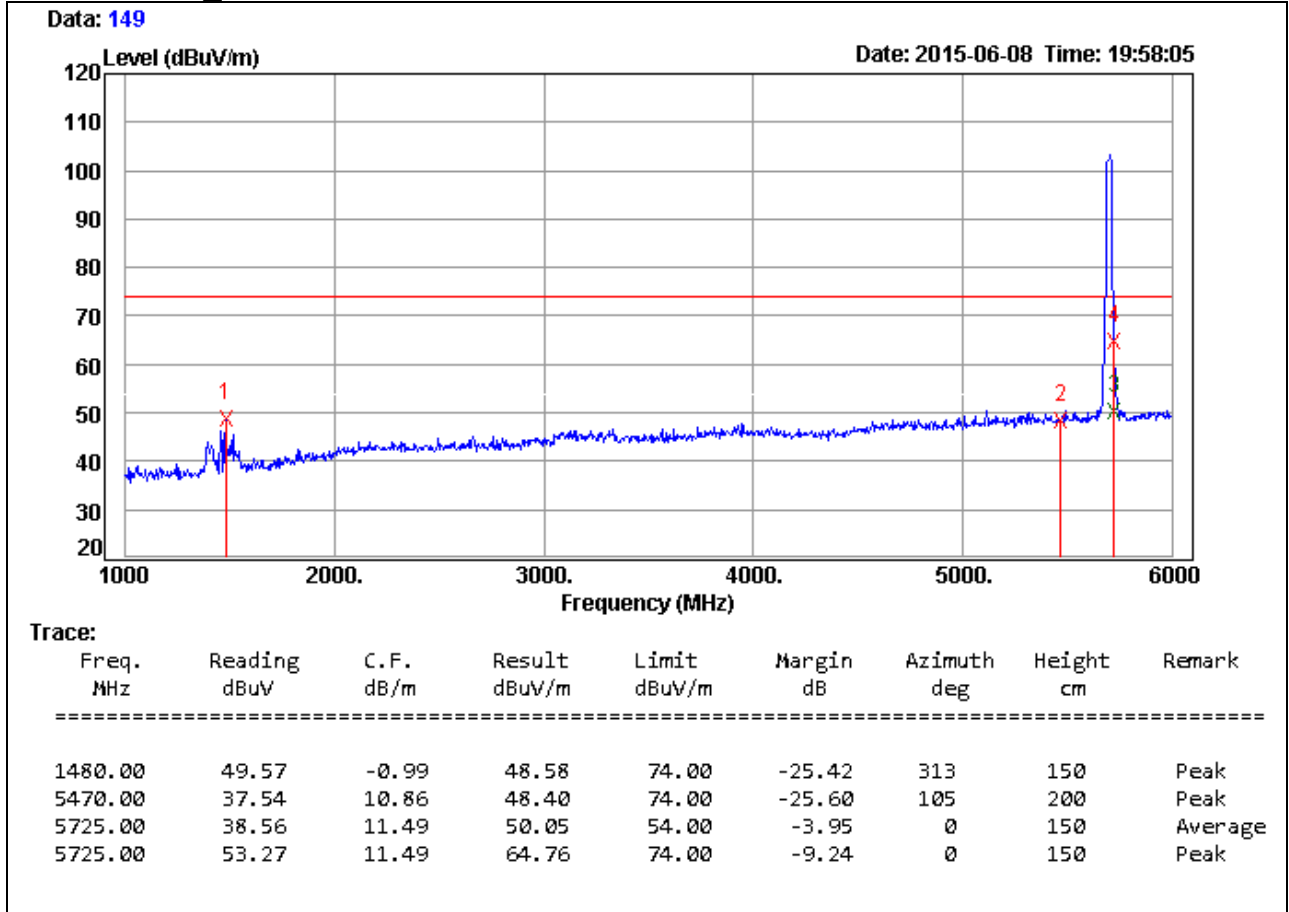

**Remark:**

1. Measuring frequencies from 1 GHz to the 10th harmonic of highest fundamental frequency.
2. Average test would be performed if the peak result were greater than the average limit.
3. Measurements above show only up to 6 maximum emissions noted, or would be lesser, with " N/A " remark, if no specific emissions from the EUT are recorded (ie: margin>20dB from the applicable limit) and considered that's already beyond the background noise floor.
4.  $Result = Reading + Correction\ Factor$   
 $Margin = Result - Limit$   
 $Remark\ Peak = Result(PK) - Limit(PK)$   
 $Remark\ AVG = Result(AV) - Limit(AV)$



<b>Product Name</b>	Computer	<b>Test By</b>	Waternil Guan
<b>Test Model</b>	POC127	<b>Test Date</b>	2015/06/04
<b>Test Mode</b>	UNII Band 2C/ IEEE 802.11a TX / CH High	<b>Temp. &amp; Humidity</b>	26°C, 52%

966 Chamber\_C at 3Meter / Horizontal

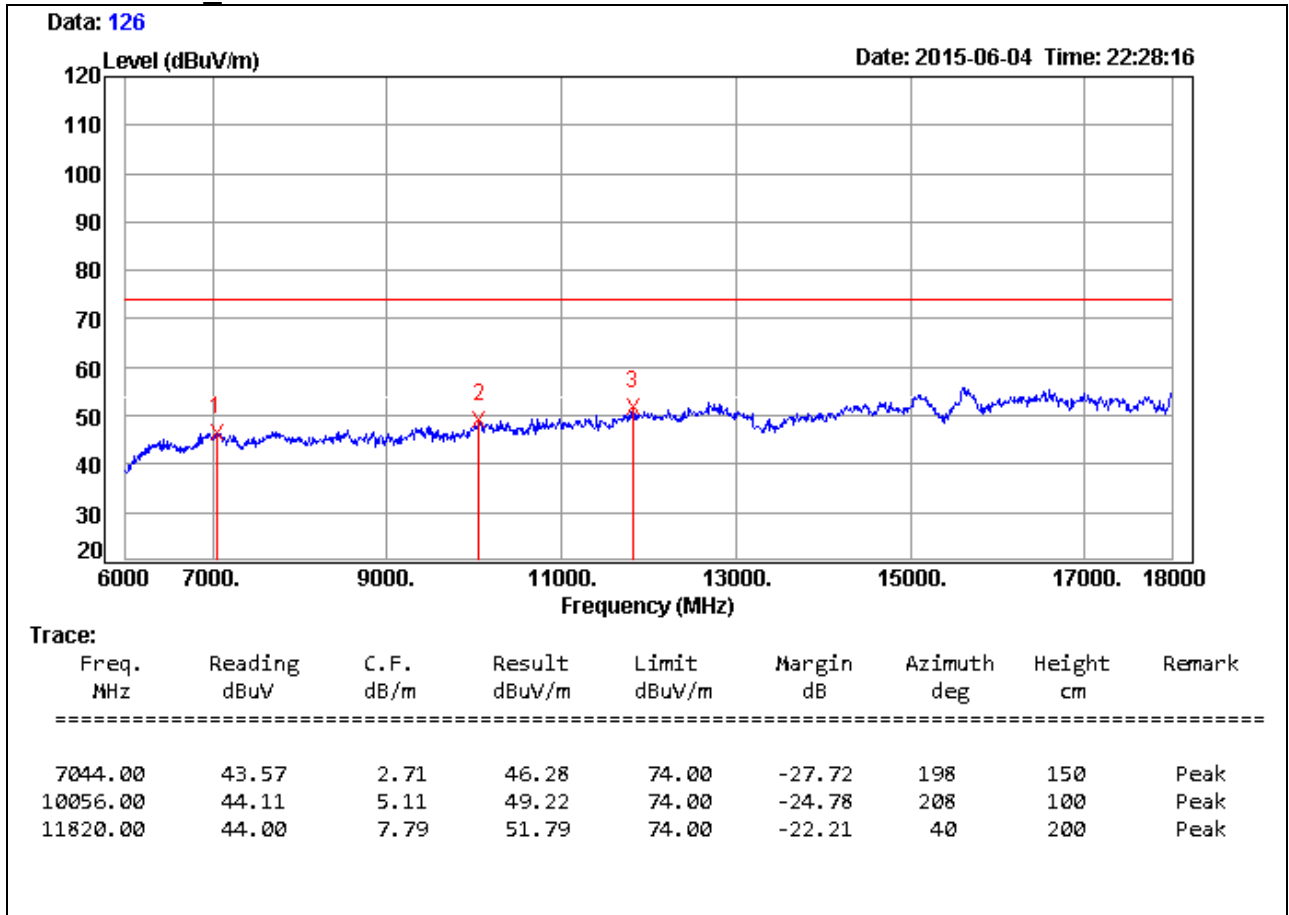

**Remark:**

1. Measuring frequencies from 1 GHz to the 10th harmonic of highest fundamental frequency.
2. Average test would be performed if the peak result were greater than the average limit.
3. Measurements above show only up to 6 maximum emissions noted, or would be lesser, with " N/A " remark, if no specific emissions from the EUT are recorded (ie: margin>20dB from the applicable limit) and considered that's already beyond the background noise floor.
4. Result = Reading + Correction Factor  
 Margin = Result - Limit  
 Remark Peak = Result(PK) - Limit(PK)  
 Remark AVG = Result(AV) - Limit(AV)
5. There is no emission in 18GHz ~ 40GHz.

<b>Product Name</b>	Computer	<b>Test By</b>	Waternil Guan
<b>Test Model</b>	POC127	<b>Test Date</b>	2015/06/08
<b>Test Mode</b>	UNII Band 2C/ IEEE 802.11a TX / CH High	<b>Temp. &amp; Humidity</b>	26°C, 52%

966 Chamber\_C at 3Meter / Vertical

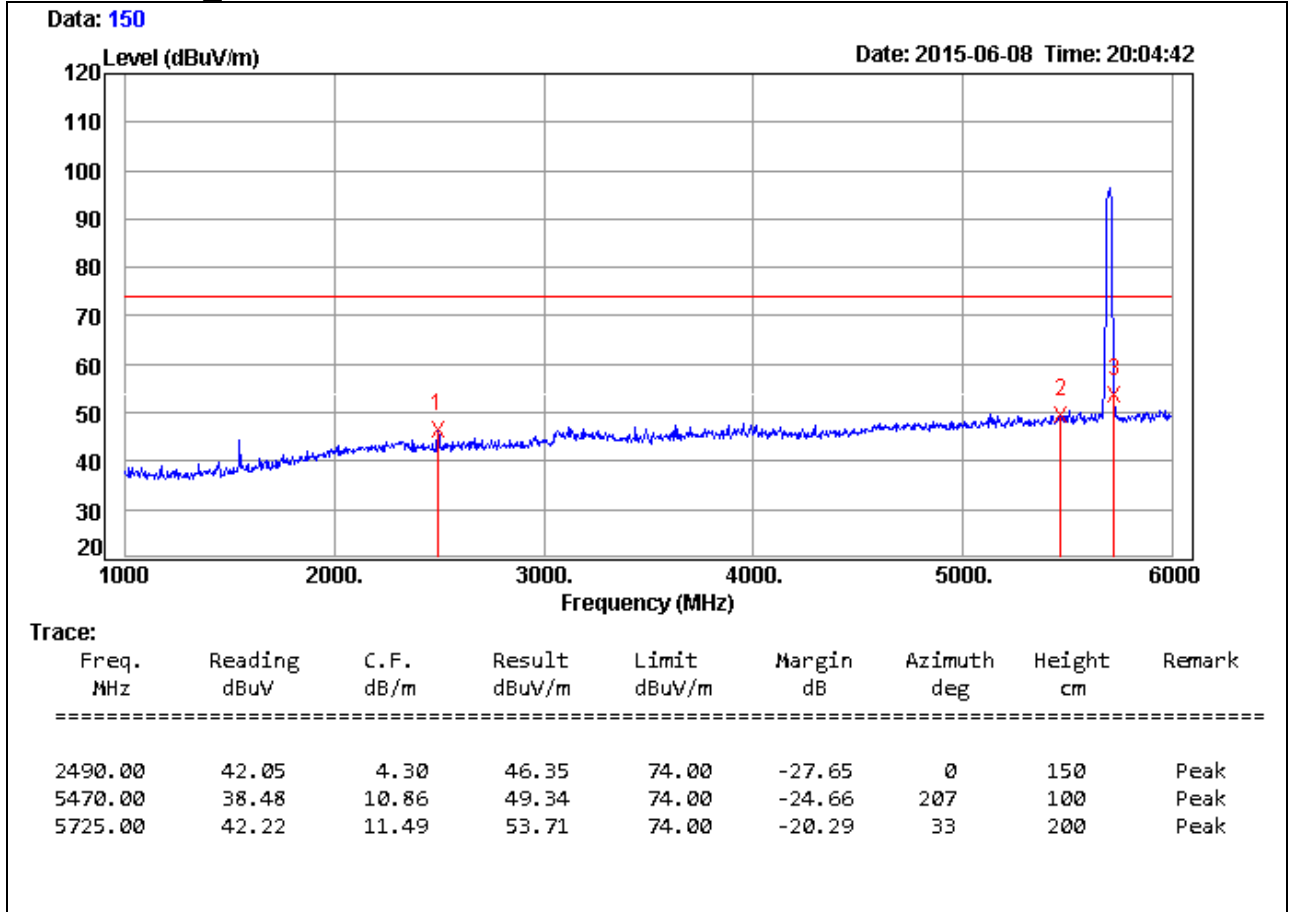

**Remark:**

1. Measuring frequencies from 1 GHz to the 10th harmonic of highest fundamental frequency.
2. Average test would be performed if the peak result were greater than the average limit.
3. Measurements above show only up to 6 maximum emissions noted, or would be lesser, with " N/A " remark, if no specific emissions from the EUT are recorded (ie: margin>20dB from the applicable limit) and considered that's already beyond the background noise floor.
4.  $Result = Reading + Correction\ Factor$   
 $Margin = Result - Limit$   
 $Remark\ Peak = Result(PK) - Limit(PK)$   
 $Remark\ AVG = Result(AV) - Limit(AV)$

<b>Product Name</b>	Computer	<b>Test By</b>	Waternil Guan
<b>Test Model</b>	POC127	<b>Test Date</b>	2015/06/04
<b>Test Mode</b>	UNII Band 2C/ IEEE 802.11a TX / CH High	<b>Temp. &amp; Humidity</b>	26°C, 52%

966 Chamber\_C at 3Meter / Vertical

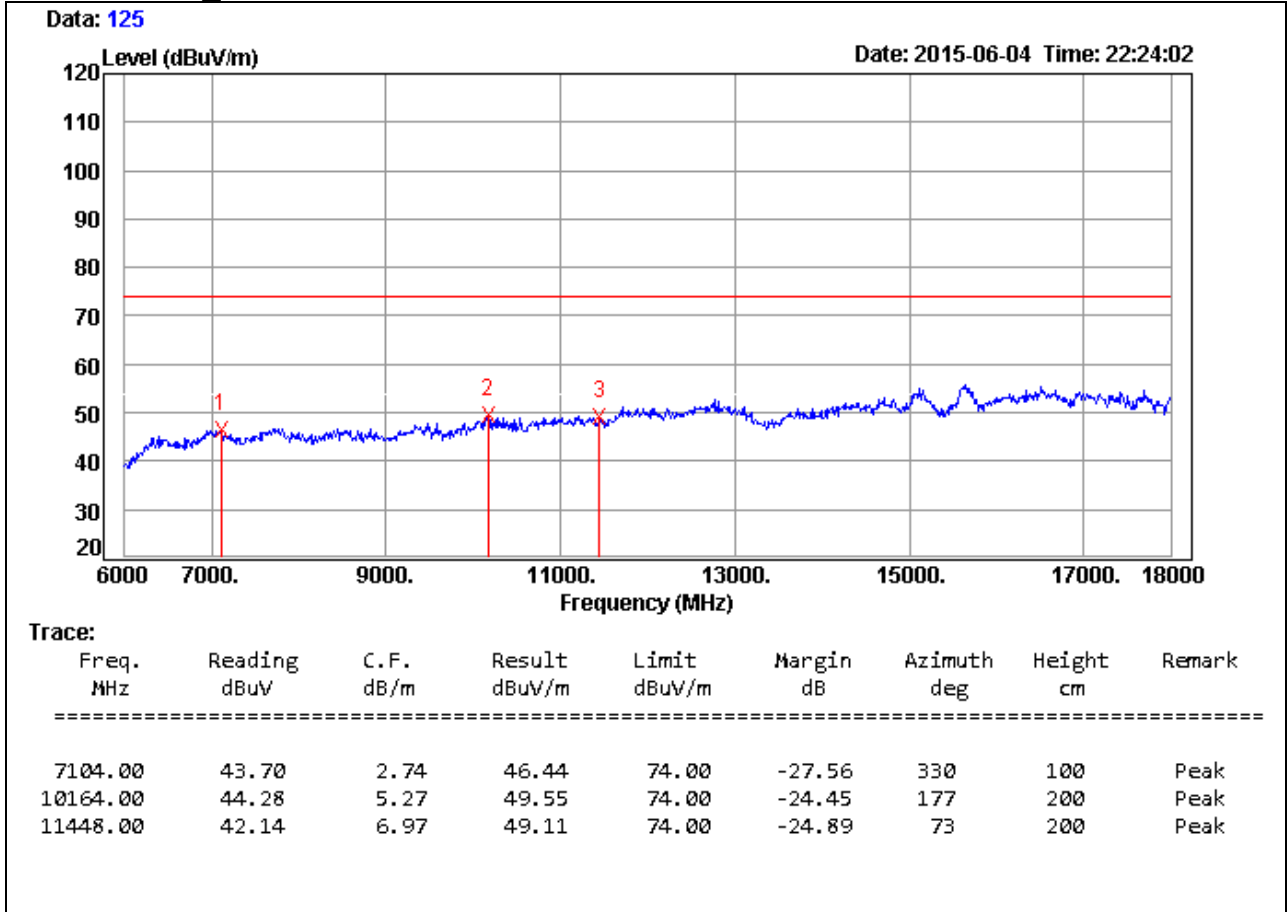

**Remark:**

1. Measuring frequencies from 1 GHz to the 10th harmonic of highest fundamental frequency.
2. Average test would be performed if the peak result were greater than the average limit.
3. Measurements above show only up to 6 maximum emissions noted, or would be lesser, with " N/A " remark, if no specific emissions from the EUT are recorded (ie: margin>20dB from the applicable limit) and considered that's already beyond the background noise floor.
4. Result = Reading + Correction Factor  
 Margin = Result - Limit  
 Remark Peak = Result(PK) - Limit(PK)  
 Remark AVG = Result(AV) - Limit(AV)
5. There is no emission in 18GHz ~ 40GHz.

<b>Product Name</b>	Computer	<b>Test By</b>	Waternil Guan
<b>Test Model</b>	POC127	<b>Test Date</b>	2015/06/22
<b>Test Mode</b>	UNII Band 2C/ IEEE 802.11an HT20 TX / CH Low	<b>Temp. &amp; Humidity</b>	26°C, 52%

966 Chamber\_C at 3Meter / Horizontal

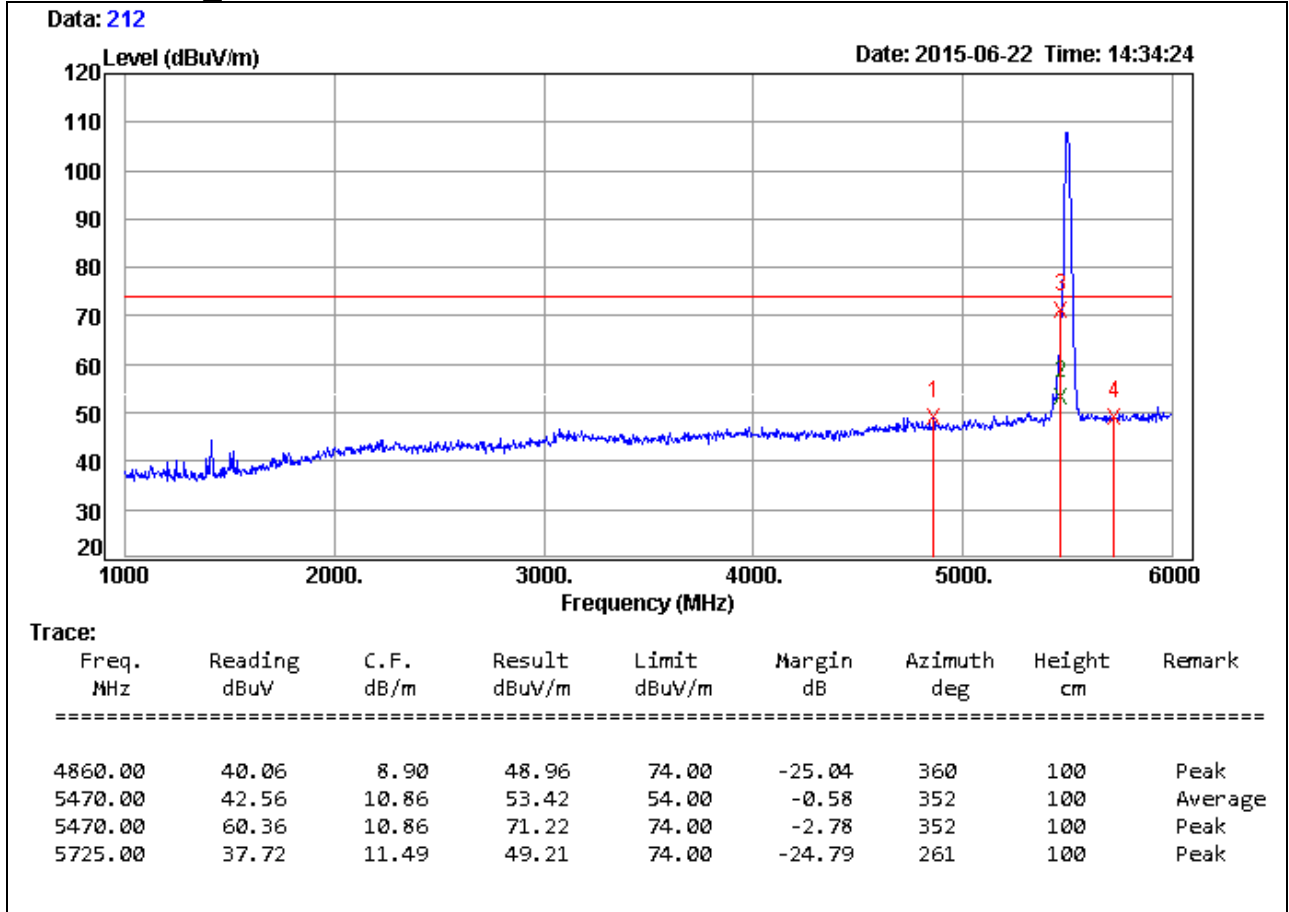

**Remark:**

1. Measuring frequencies from 1 GHz to the 10th harmonic of highest fundamental frequency.
2. Average test would be performed if the peak result were greater than the average limit.
3. Measurements above show only up to 6 maximum emissions noted, or would be lesser, with " N/A " remark, if no specific emissions from the EUT are recorded (ie: margin>20dB from the applicable limit) and considered that's already beyond the background noise floor.
4. Result = Reading + Correction Factor  
 Margin = Result - Limit  
 Remark Peak = Result(PK) - Limit(PK)  
 Remark AVG = Result(AV) - Limit(AV)

<b>Product Name</b>	Computer	<b>Test By</b>	Waternil Guan
<b>Test Model</b>	POC127	<b>Test Date</b>	2015/06/18
<b>Test Mode</b>	UNII Band 2C/ IEEE 802.11an HT20 TX / CH Low	<b>Temp. &amp; Humidity</b>	26°C, 52%

966 Chamber\_C at 3Meter / Horizontal

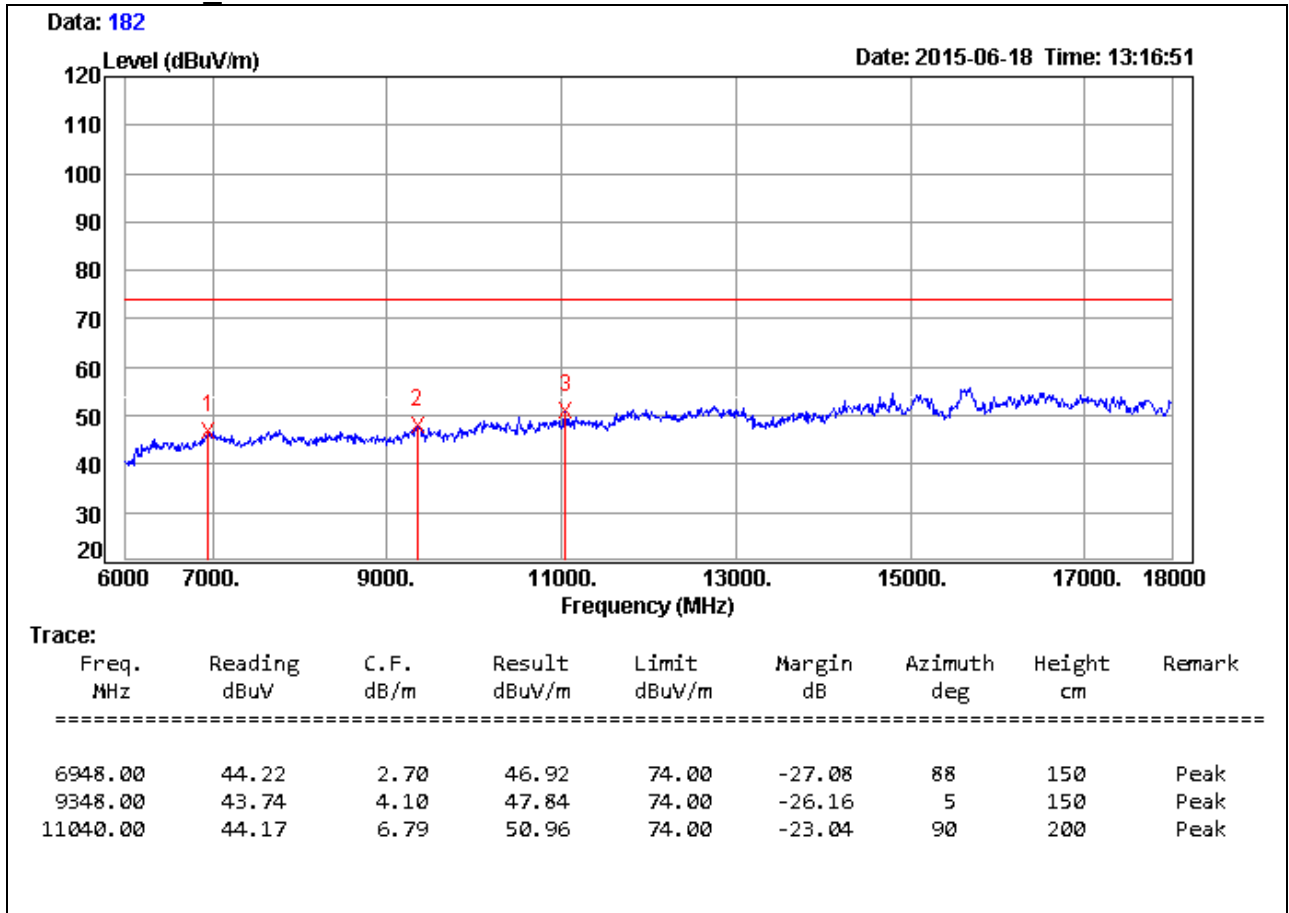

**Remark:**

1. Measuring frequencies from 1 GHz to the 10th harmonic of highest fundamental frequency.
2. Average test would be performed if the peak result were greater than the average limit.
3. Measurements above show only up to 6 maximum emissions noted, or would be lesser, with " N/A " remark, if no specific emissions from the EUT are recorded (ie: margin>20dB from the applicable limit) and considered that's already beyond the background noise floor.
4. Result = Reading + Correction Factor  
Margin = Result - Limit  
Remark Peak = Result(PK) - Limit(PK)  
Remark AVG = Result(AV) - Limit(AV)
5. There is no emission in 18GHz ~ 40GHz.

<b>Product Name</b>	Computer	<b>Test By</b>	Waternil Guan
<b>Test Model</b>	POC127	<b>Test Date</b>	2015/06/22
<b>Test Mode</b>	UNII Band 2C/ IEEE 802.11an HT20 TX / CH Low	<b>Temp. &amp; Humidity</b>	26°C, 52%

966 Chamber\_C at 3Meter / Vertical

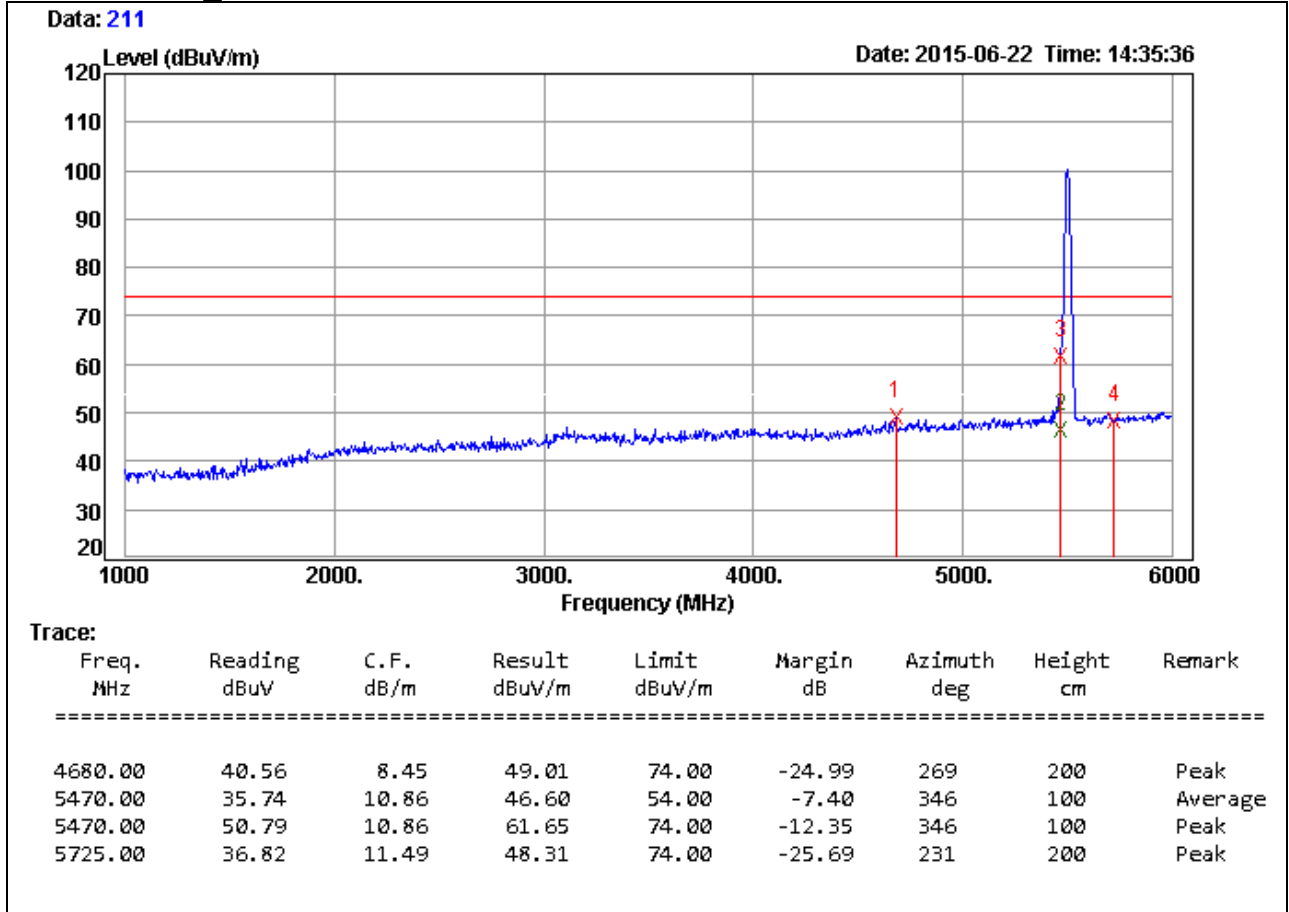

**Remark:**

1. Measuring frequencies from 1 GHz to the 10th harmonic of highest fundamental frequency.
2. Average test would be performed if the peak result were greater than the average limit.
3. Measurements above show only up to 6 maximum emissions noted, or would be lesser, with " N/A " remark, if no specific emissions from the EUT are recorded (ie: margin>20dB from the applicable limit) and considered that's already beyond the background noise floor.
4. Result = Reading + Correction Factor  
 Margin = Result - Limit  
 Remark Peak = Result(PK) - Limit(PK)  
 Remark AVG = Result(AV) - Limit(AV)

<b>Product Name</b>	Computer	<b>Test By</b>	Waternil Guan
<b>Test Model</b>	POC127	<b>Test Date</b>	2015/06/18
<b>Test Mode</b>	UNII Band 2C/ IEEE 802.11an HT20 TX / CH Low	<b>Temp. &amp; Humidity</b>	26°C, 52%

966 Chamber\_C at 3Meter / Vertical

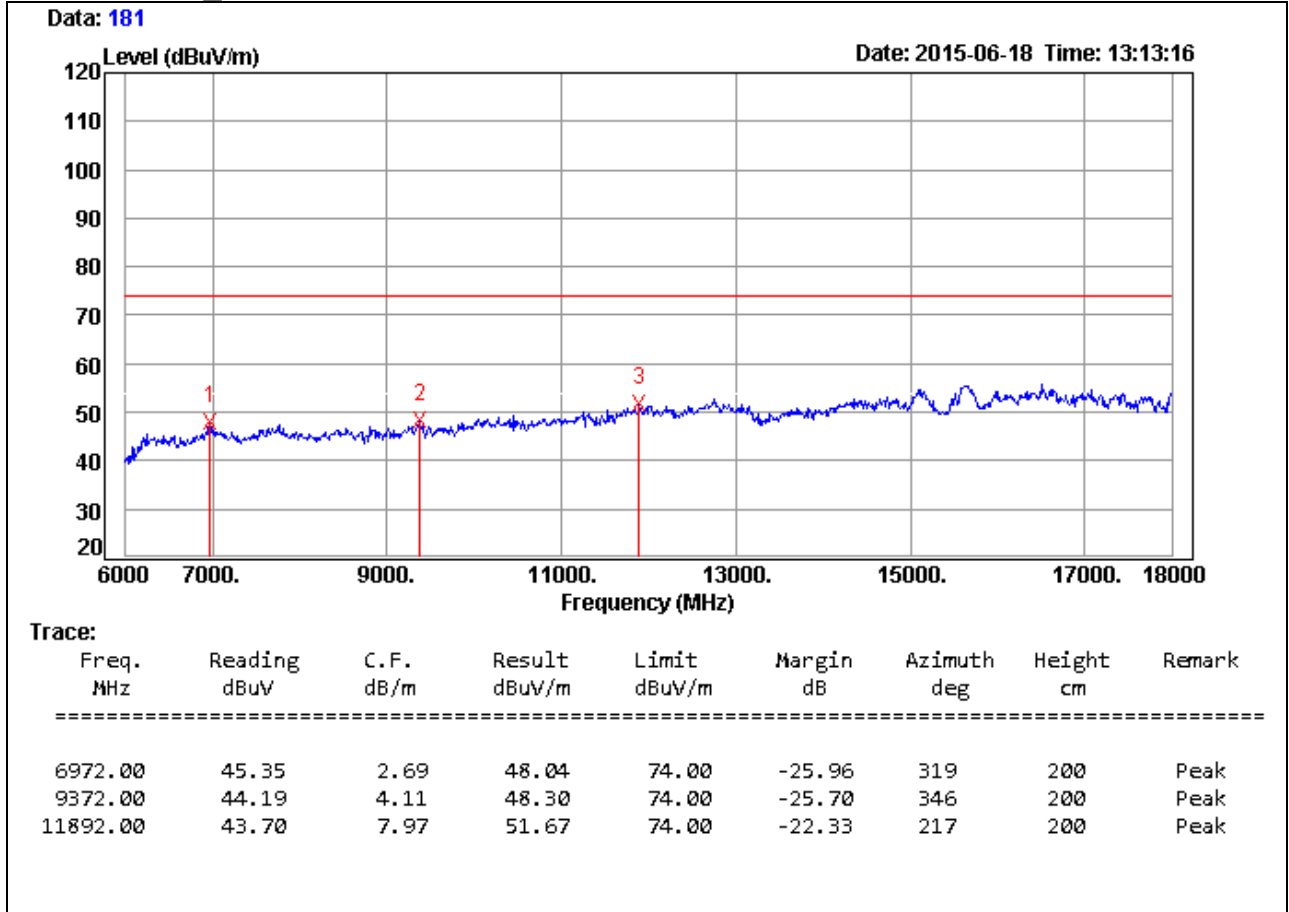

**Remark:**

1. Measuring frequencies from 1 GHz to the 10th harmonic of highest fundamental frequency.
2. Average test would be performed if the peak result were greater than the average limit.
3. Measurements above show only up to 6 maximum emissions noted, or would be lesser, with " N/A " remark, if no specific emissions from the EUT are recorded (ie: margin>20dB from the applicable limit) and considered that's already beyond the background noise floor.
4. Result = Reading + Correction Factor  
Margin = Result – Limit  
Remark Peak = Result(PK) – Limit(PK)  
Remark AVG = Result(AV) – Limit(AV)
5. There is no emission in 18GHz ~ 40GHz.

<b>Product Name</b>	Computer	<b>Test By</b>	Waternil Guan
<b>Test Model</b>	POC127	<b>Test Date</b>	2015/06/22
<b>Test Mode</b>	UNII Band 2C/ IEEE 802.11an HT20 TX / CH Middle	<b>Temp. &amp; Humidity</b>	26°C, 52%

966 Chamber\_C at 3Meter / Horizontal

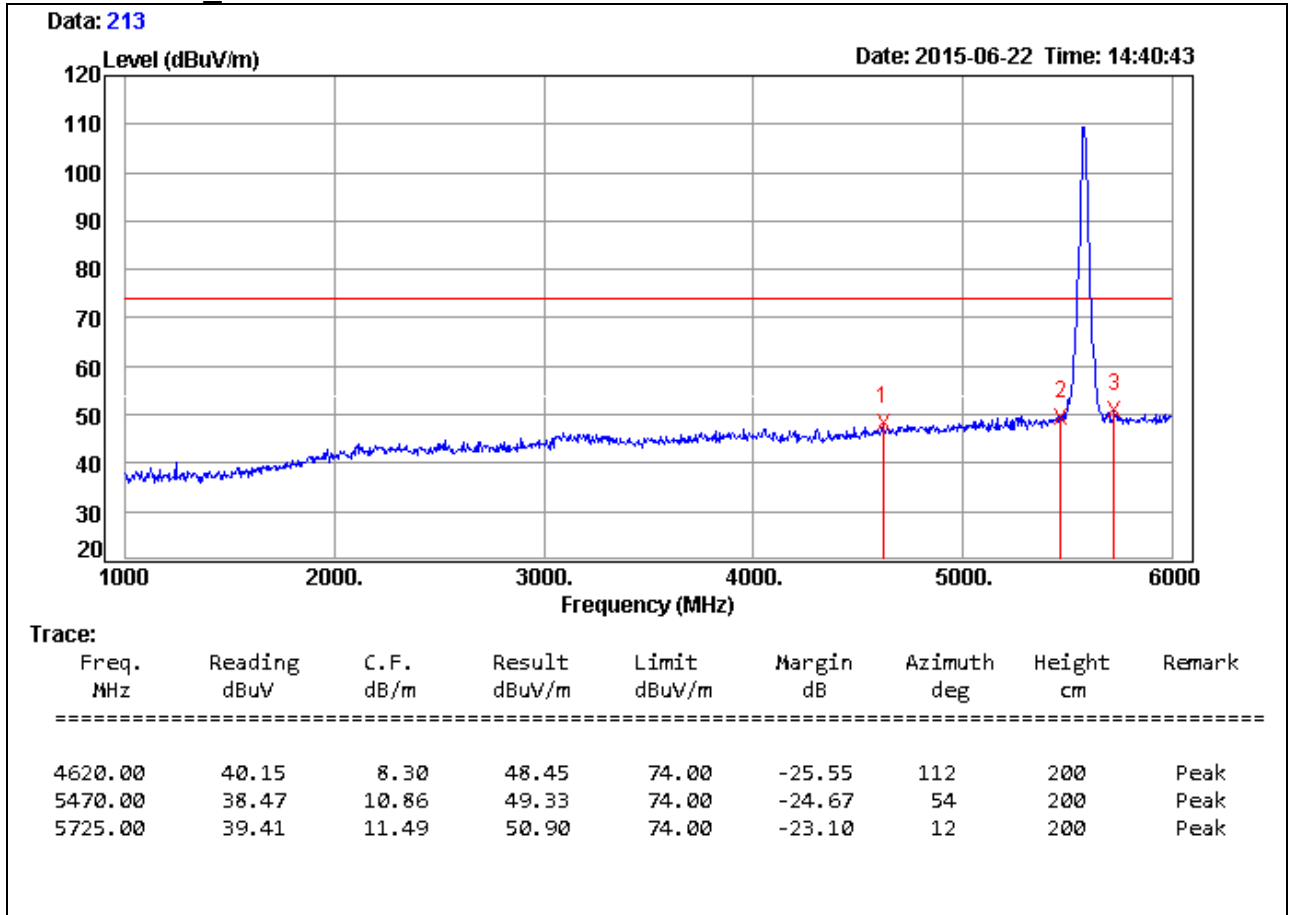

**Remark:**

1. Measuring frequencies from 1 GHz to the 10th harmonic of highest fundamental frequency.
2. Average test would be performed if the peak result were greater than the average limit.
3. Measurements above show only up to 6 maximum emissions noted, or would be lesser, with " N/A " remark, if no specific emissions from the EUT are recorded (ie: margin>20dB from the applicable limit) and considered that's already beyond the background noise floor.
4. Result = Reading + Correction Factor  
Margin = Result - Limit  
Remark Peak = Result(PK) - Limit(PK)  
Remark AVG = Result(AV) - Limit(AV)



<b>Product Name</b>	Computer	<b>Test By</b>	Waternil Guan
<b>Test Model</b>	POC127	<b>Test Date</b>	2015/06/18
<b>Test Mode</b>	UNII Band 2C/ IEEE 802.11an HT20 TX / CH Middle	<b>Temp. &amp; Humidity</b>	26°C, 52%

966 Chamber\_C at 3Meter / Horizontal

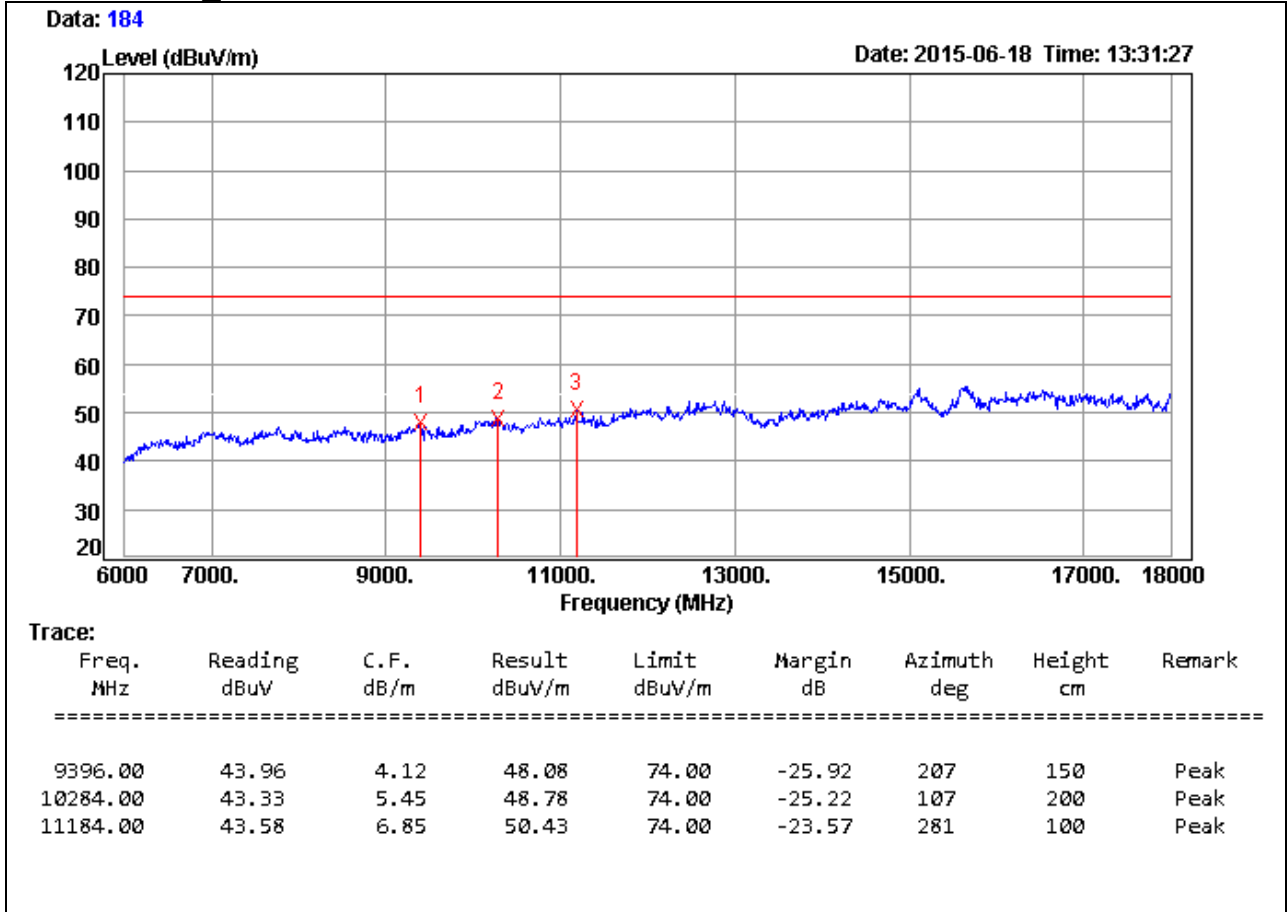

**Remark:**

1. Measuring frequencies from 1 GHz to the 10th harmonic of highest fundamental frequency.
2. Average test would be performed if the peak result were greater than the average limit.
3. Measurements above show only up to 6 maximum emissions noted, or would be lesser, with " N/A " remark, if no specific emissions from the EUT are recorded (ie: margin>20dB from the applicable limit) and considered that's already beyond the background noise floor.
4. Result = Reading + Correction Factor  
Margin = Result - Limit  
Remark Peak = Result(PK) - Limit(PK)  
Remark AVG = Result(AV) - Limit(AV)
5. There is no emission in 18GHz ~ 40GHz.

<b>Product Name</b>	Computer	<b>Test By</b>	Waternil Guan
<b>Test Model</b>	POC127	<b>Test Date</b>	2015/06/22
<b>Test Mode</b>	UNII Band 2C/ IEEE 802.11an HT20 TX / CH Middle	<b>Temp. &amp; Humidity</b>	26°C, 52%

966 Chamber\_C at 3Meter / Vertical

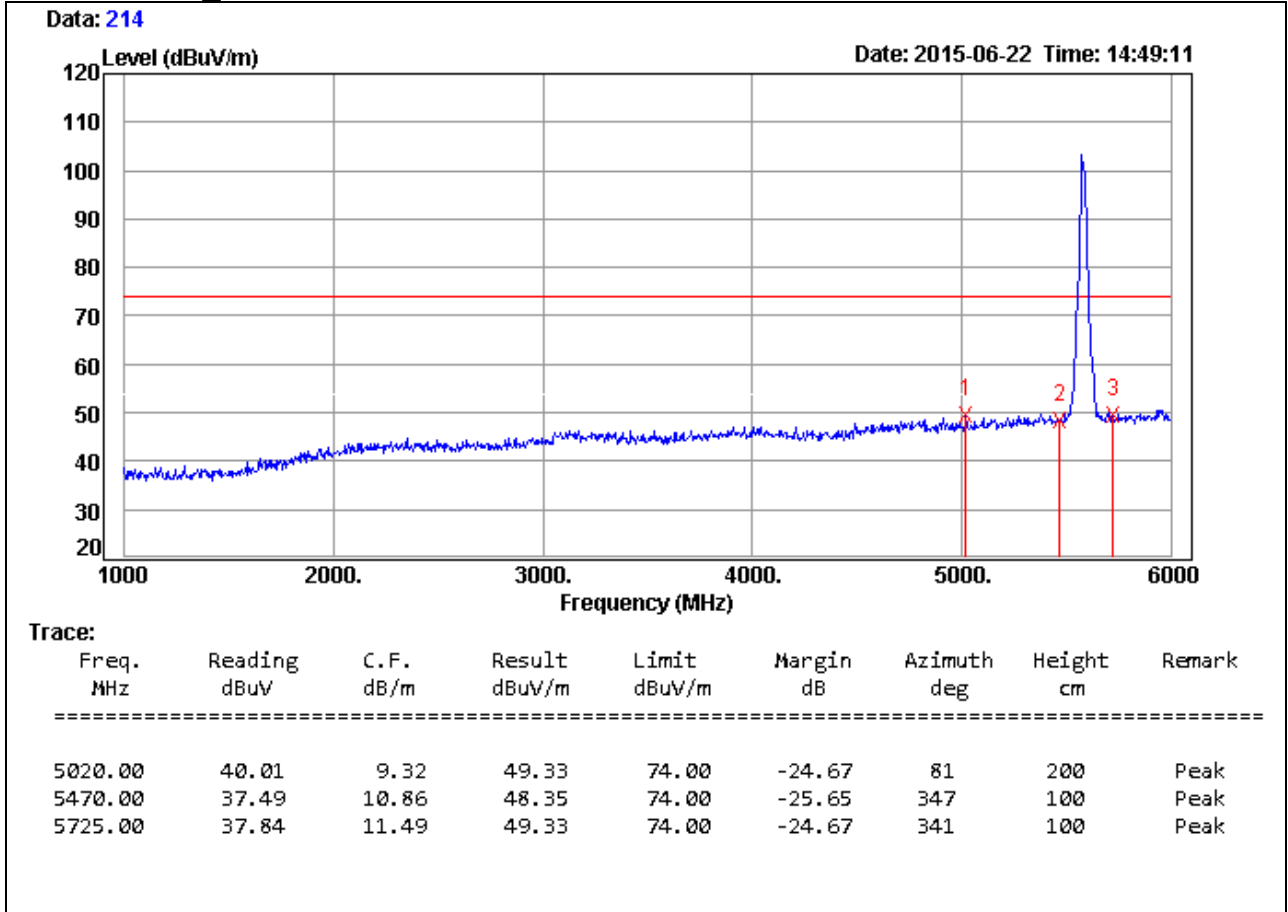

**Remark:**

1. Measuring frequencies from 1 GHz to the 10th harmonic of highest fundamental frequency.
2. Average test would be performed if the peak result were greater than the average limit.
3. Measurements above show only up to 6 maximum emissions noted, or would be lesser, with " N/A " remark, if no specific emissions from the EUT are recorded (ie: margin>20dB from the applicable limit) and considered that's already beyond the background noise floor.
4. Result = Reading + Correction Factor  
 Margin = Result - Limit  
 Remark Peak = Result(PK) - Limit(PK)  
 Remark AVG = Result(AV) - Limit(AV)

<b>Product Name</b>	Computer	<b>Test By</b>	Waternil Guan
<b>Test Model</b>	POC127	<b>Test Date</b>	2015/06/18
<b>Test Mode</b>	UNII Band 2C/ IEEE 802.11an HT20 TX / CH Middle	<b>Temp. &amp; Humidity</b>	26°C, 52%

966 Chamber\_C at 3Meter / Vertical

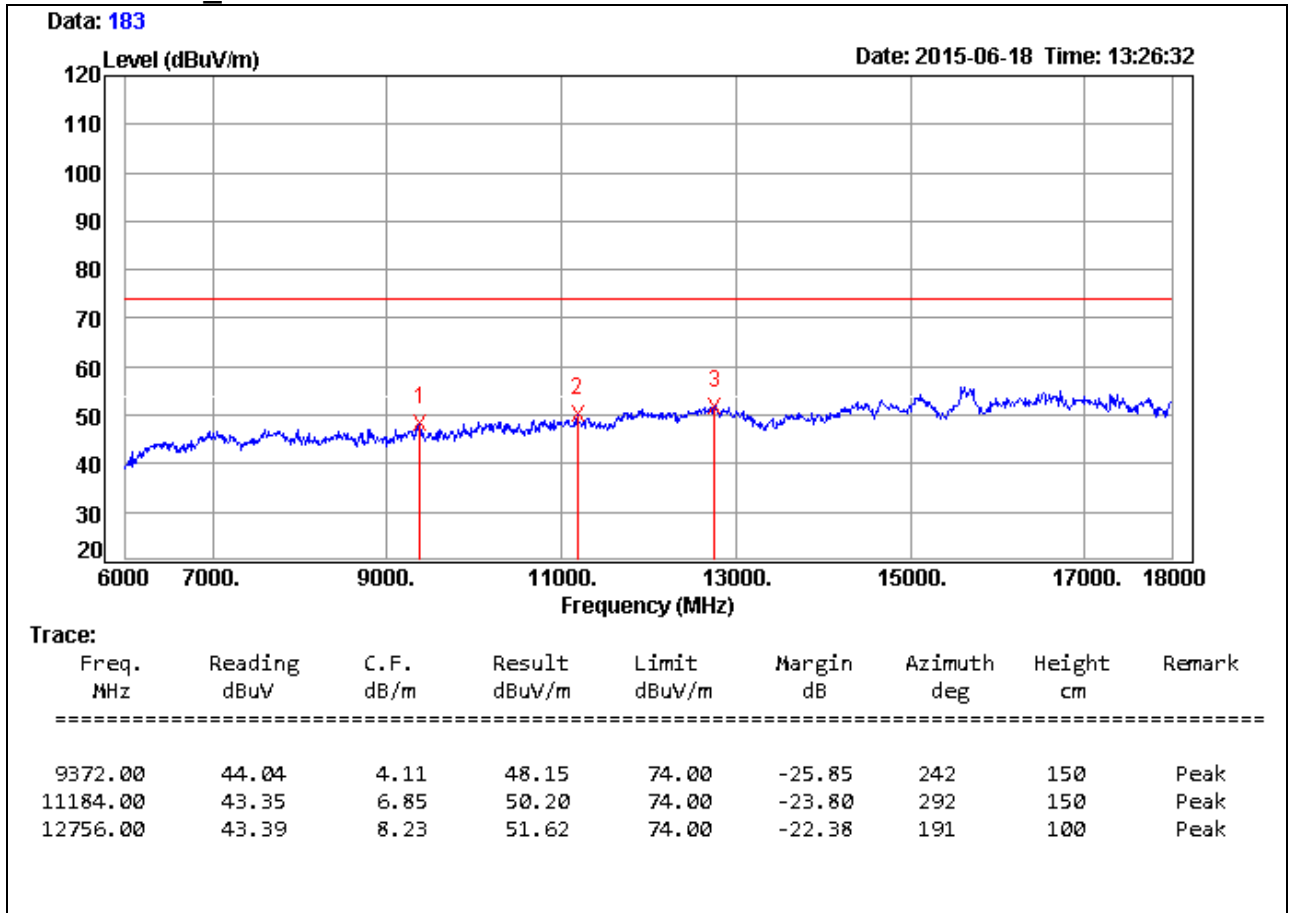

**Remark:**

1. Measuring frequencies from 1 GHz to the 10th harmonic of highest fundamental frequency.
2. Average test would be performed if the peak result were greater than the average limit.
3. Measurements above show only up to 6 maximum emissions noted, or would be lesser, with " N/A " remark, if no specific emissions from the EUT are recorded (ie: margin>20dB from the applicable limit) and considered that's already beyond the background noise floor.
4. Result = Reading + Correction Factor  
Margin = Result - Limit  
Remark Peak = Result(PK) - Limit(PK)  
Remark AVG = Result(AV) - Limit(AV)
5. There is no emission in 18GHz ~ 40GHz.

<b>Product Name</b>	Computer	<b>Test By</b>	Waternil Guan
<b>Test Model</b>	POC127	<b>Test Date</b>	2015/06/22
<b>Test Mode</b>	UNII Band 2C/ IEEE 802.11an HT20 TX / CH High	<b>Temp. &amp; Humidity</b>	26°C, 52%

966 Chamber\_C at 3Meter / Horizontal

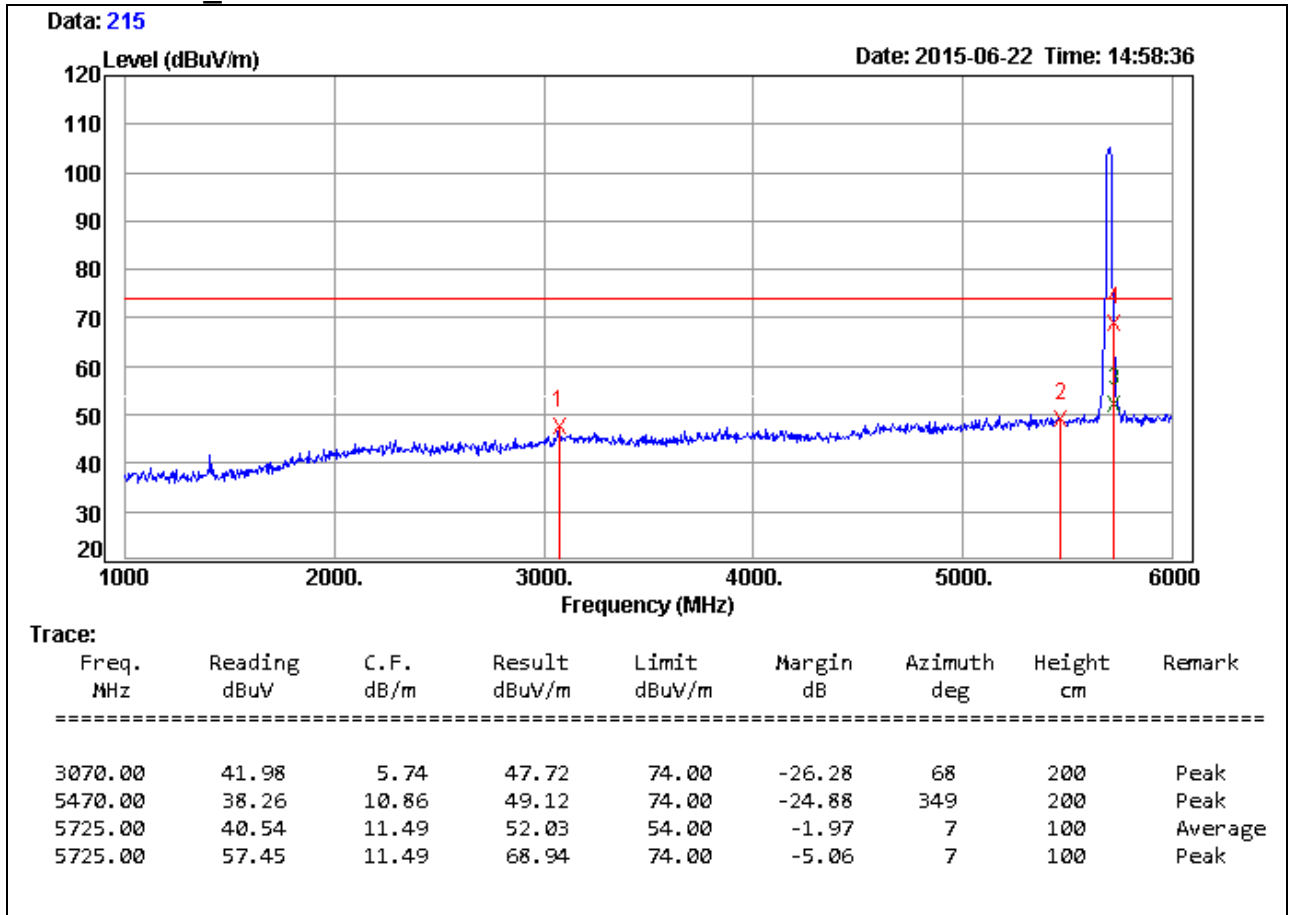

**Remark:**

1. Measuring frequencies from 1 GHz to the 10th harmonic of highest fundamental frequency.
2. Average test would be performed if the peak result were greater than the average limit.
3. Measurements above show only up to 6 maximum emissions noted, or would be lesser, with " N/A " remark, if no specific emissions from the EUT are recorded (ie: margin>20dB from the applicable limit) and considered that's already beyond the background noise floor.
4. Result = Reading + Correction Factor  
Margin = Result - Limit  
Remark Peak = Result(PK) - Limit(PK)  
Remark AVG = Result(AV) - Limit(AV)

<b>Product Name</b>	Computer	<b>Test By</b>	Waternil Guan
<b>Test Model</b>	POC127	<b>Test Date</b>	2015/06/18
<b>Test Mode</b>	UNII Band 2C/ IEEE 802.11an HT20 TX / CH High	<b>Temp. &amp; Humidity</b>	26°C, 52%

966 Chamber\_C at 3Meter / Horizontal

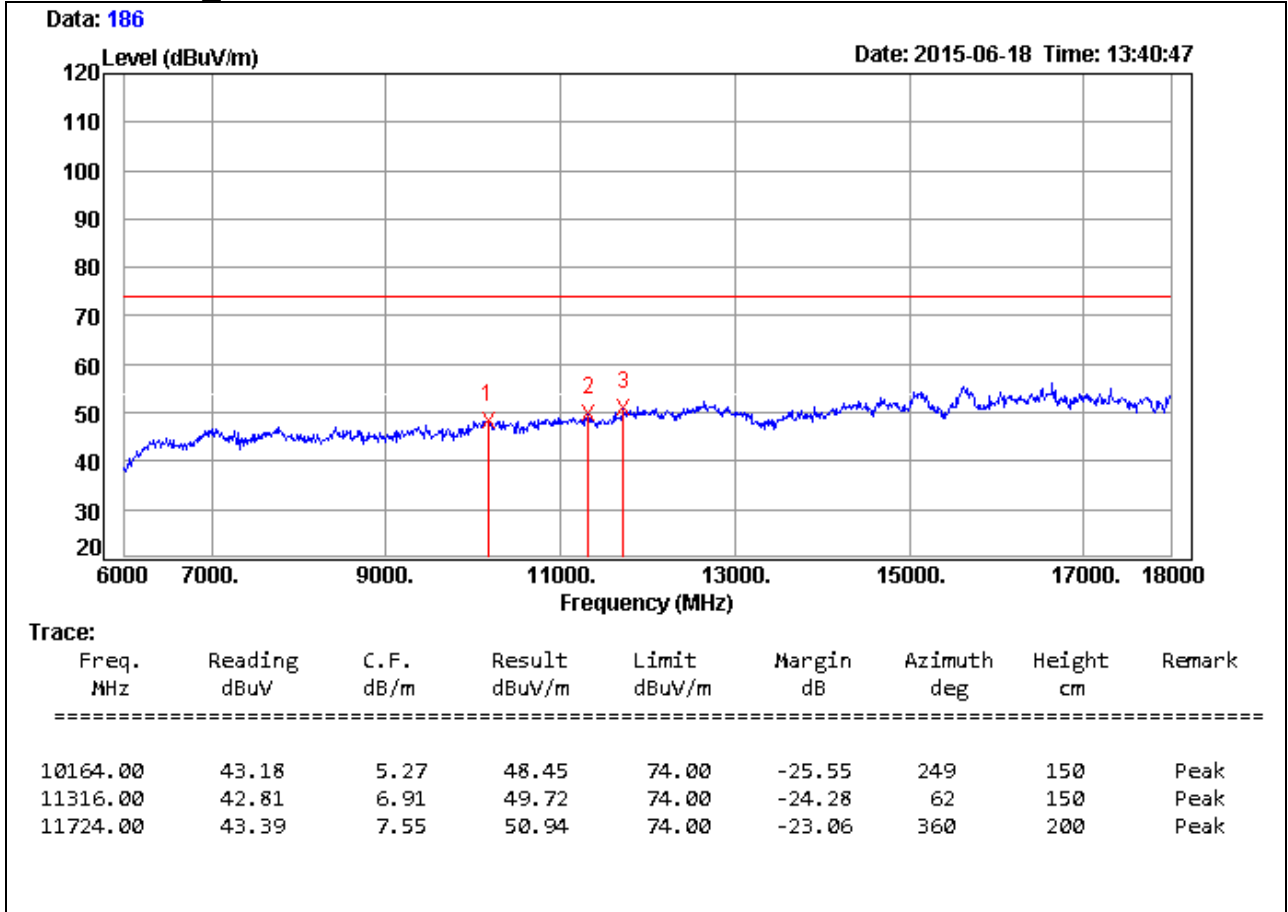

**Remark:**

1. Measuring frequencies from 1 GHz to the 10th harmonic of highest fundamental frequency.
2. Average test would be performed if the peak result were greater than the average limit.
3. Measurements above show only up to 6 maximum emissions noted, or would be lesser, with " N/A " remark, if no specific emissions from the EUT are recorded (ie: margin>20dB from the applicable limit) and considered that's already beyond the background noise floor.
4. Result = Reading + Correction Factor  
Margin = Result - Limit  
Remark Peak = Result(PK) - Limit(PK)  
Remark AVG = Result(AV) - Limit(AV)
5. There is no emission in 18GHz ~ 40GHz.

<b>Product Name</b>	Computer	<b>Test By</b>	Waternil Guan
<b>Test Model</b>	POC127	<b>Test Date</b>	2015/06/22
<b>Test Mode</b>	UNII Band 2C/ IEEE 802.11an HT20 TX / CH High	<b>Temp. &amp; Humidity</b>	26°C, 52%

966 Chamber\_C at 3Meter / Vertical

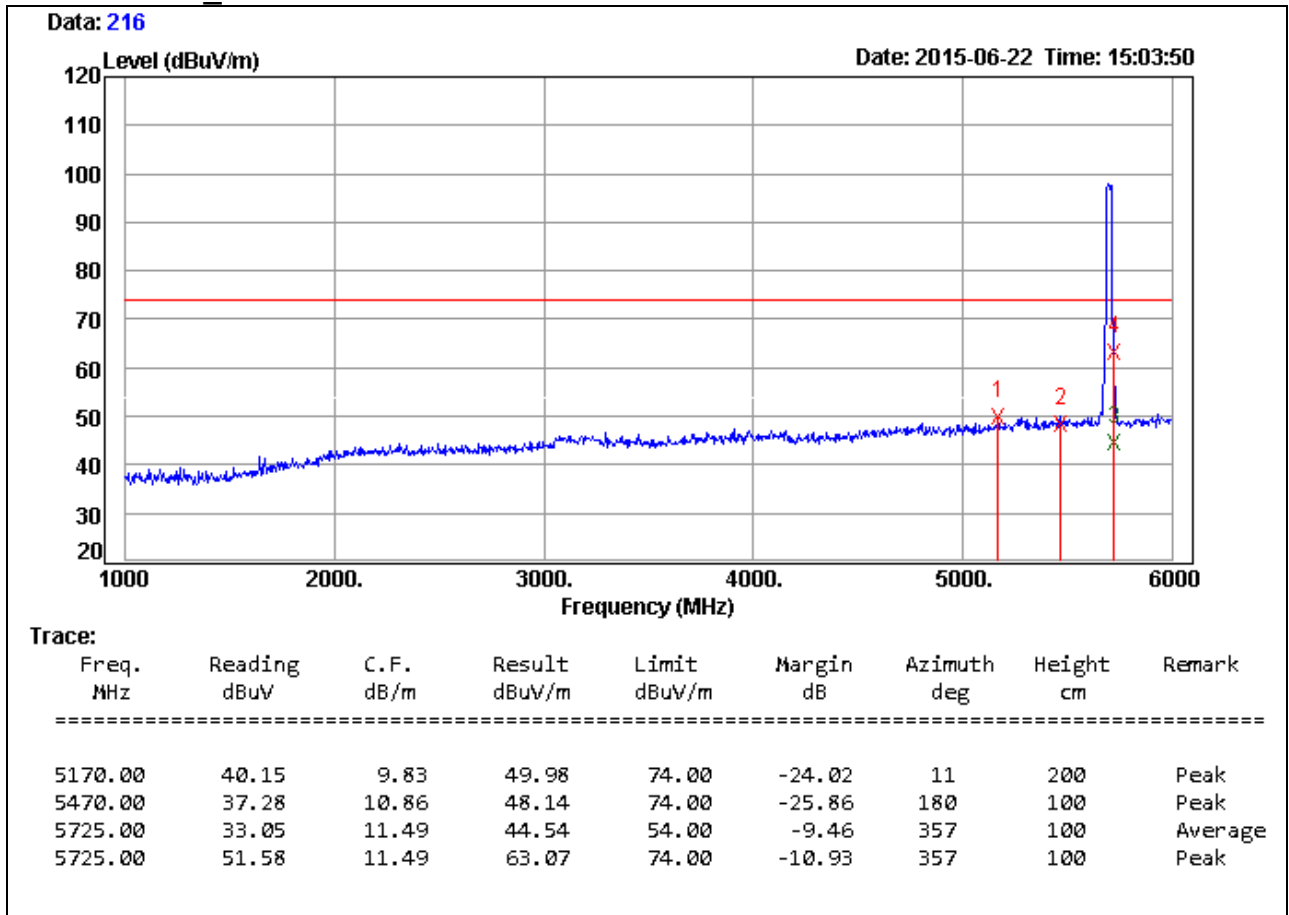

**Remark:**

1. Measuring frequencies from 1 GHz to the 10th harmonic of highest fundamental frequency.
2. Average test would be performed if the peak result were greater than the average limit.
3. Measurements above show only up to 6 maximum emissions noted, or would be lesser, with " N/A " remark, if no specific emissions from the EUT are recorded (ie: margin>20dB from the applicable limit) and considered that's already beyond the background noise floor.
4. Result = Reading + Correction Factor  
 Margin = Result - Limit  
 Remark Peak = Result(PK) - Limit(PK)  
 Remark AVG = Result(AV) - Limit(AV)

<b>Product Name</b>	Computer	<b>Test By</b>	Waternil Guan
<b>Test Model</b>	POC127	<b>Test Date</b>	2015/06/18
<b>Test Mode</b>	UNII Band 2C/ IEEE 802.11an HT20 TX / CH High	<b>Temp. &amp; Humidity</b>	26°C, 52%

966 Chamber\_C at 3Meter / Vertical

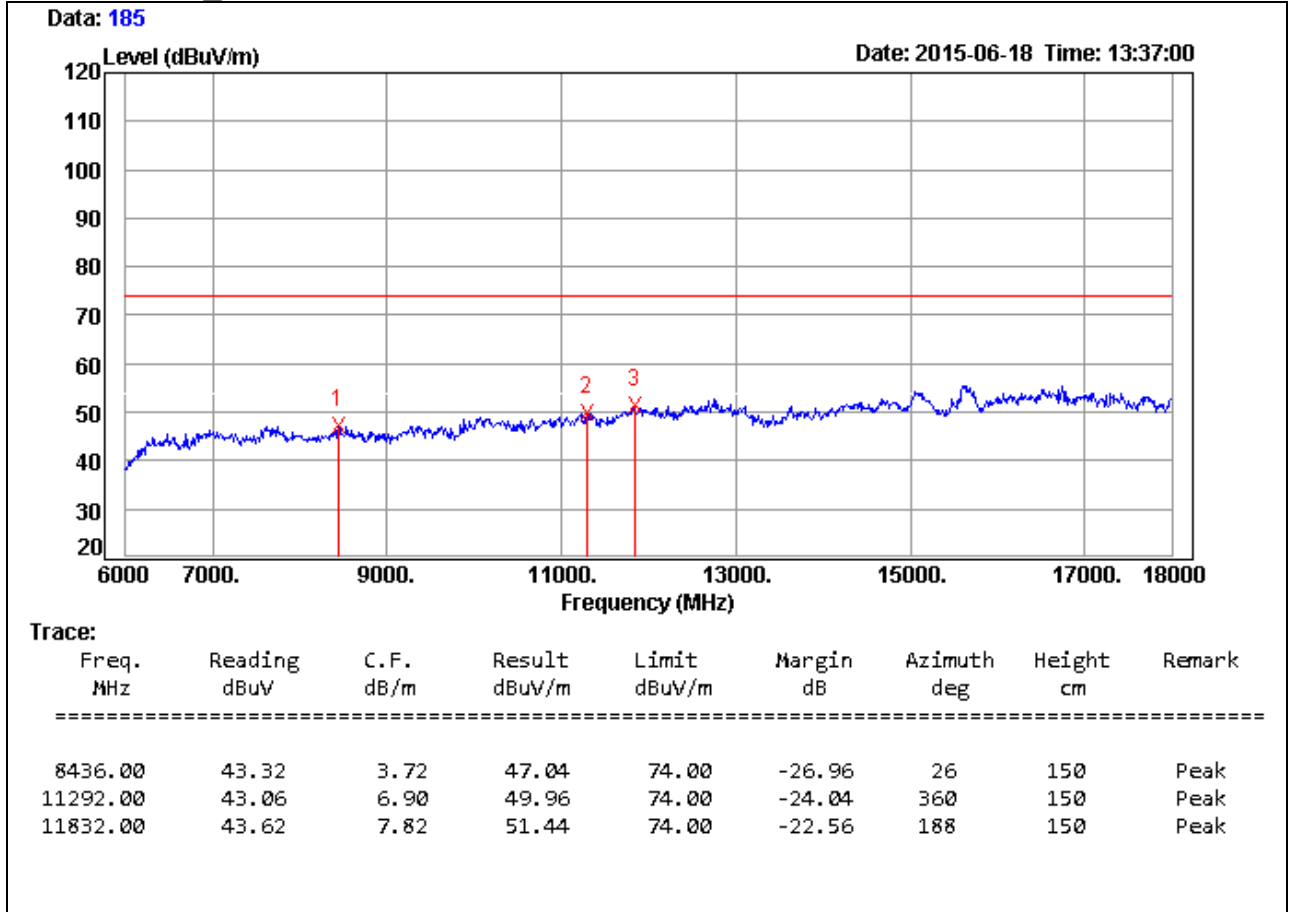

**Remark:**

1. Measuring frequencies from 1 GHz to the 10th harmonic of highest fundamental frequency.
2. Average test would be performed if the peak result were greater than the average limit.
3. Measurements above show only up to 6 maximum emissions noted, or would be lesser, with " N/A " remark, if no specific emissions from the EUT are recorded (ie: margin>20dB from the applicable limit) and considered that's already beyond the background noise floor.
4. Result = Reading + Correction Factor  
 Margin = Result – Limit  
 Remark Peak = Result(PK) – Limit(PK)  
 Remark AVG = Result(AV) – Limit(AV)
5. There is no emission in 18GHz ~ 40GHz.

<b>Product Name</b>	Computer	<b>Test By</b>	Waternil Guan
<b>Test Model</b>	POC127	<b>Test Date</b>	2015/06/22
<b>Test Mode</b>	UNII Band 2C/ IEEE 802.11an HT40 TX / CH Low	<b>Temp. &amp; Humidity</b>	26°C, 52%

966 Chamber\_C at 3Meter / Horizontal

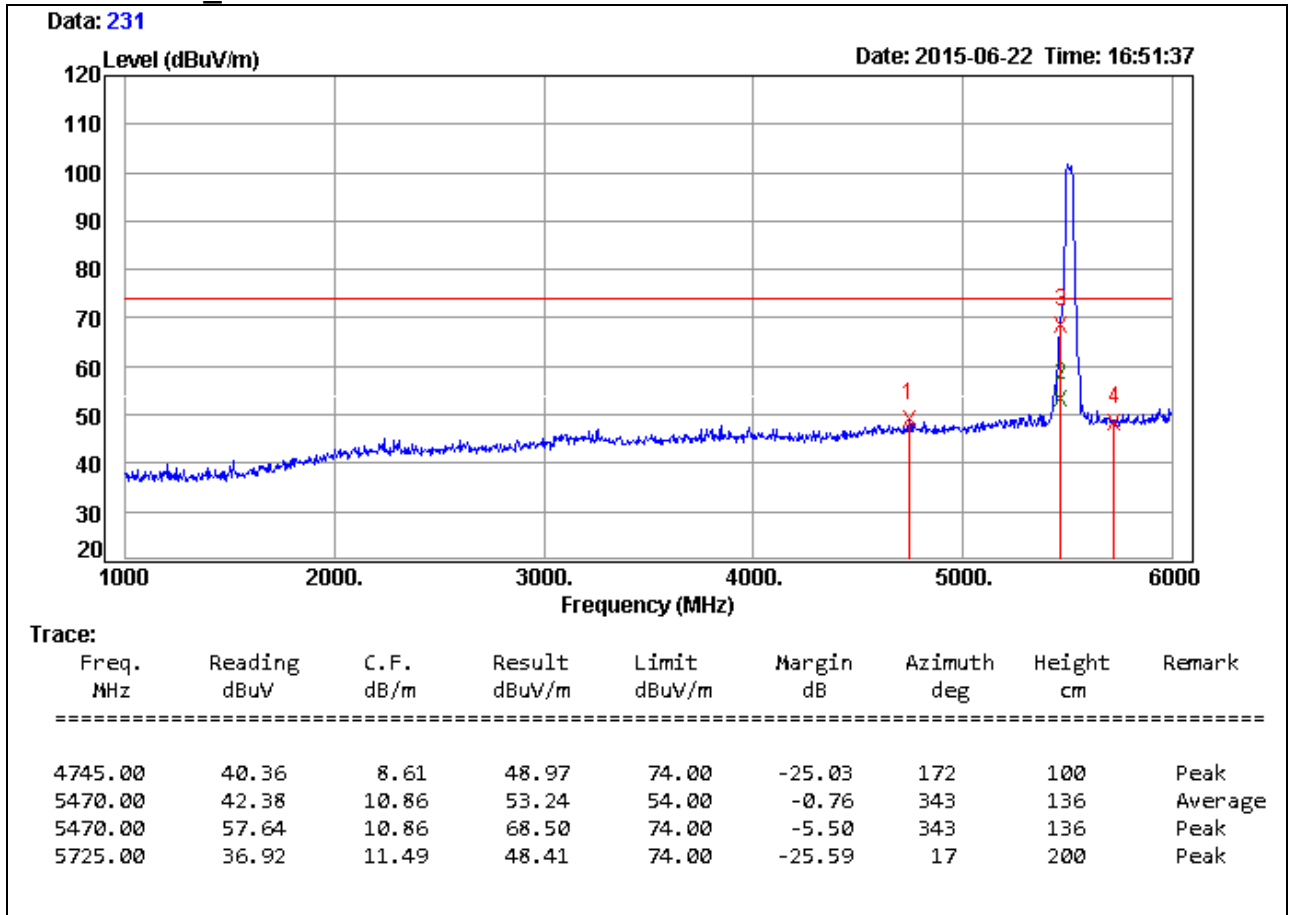

**Remark:**

1. Measuring frequencies from 1 GHz to the 10th harmonic of highest fundamental frequency.
2. Average test would be performed if the peak result were greater than the average limit.
3. Measurements above show only up to 6 maximum emissions noted, or would be lesser, with " N/A " remark, if no specific emissions from the EUT are recorded (ie: margin>20dB from the applicable limit) and considered that's already beyond the background noise floor.
4. Result = Reading + Correction Factor  
Margin = Result - Limit  
Remark Peak = Result(PK) - Limit(PK)  
Remark AVG = Result(AV) - Limit(AV)



<b>Product Name</b>	Computer	<b>Test By</b>	Waternil Guan
<b>Test Model</b>	POC127	<b>Test Date</b>	2015/06/18
<b>Test Mode</b>	UNII Band 2C/ IEEE 802.11an HT40 TX / CH Low	<b>Temp. &amp; Humidity</b>	26°C, 52%

966 Chamber\_C at 3Meter / Horizontal

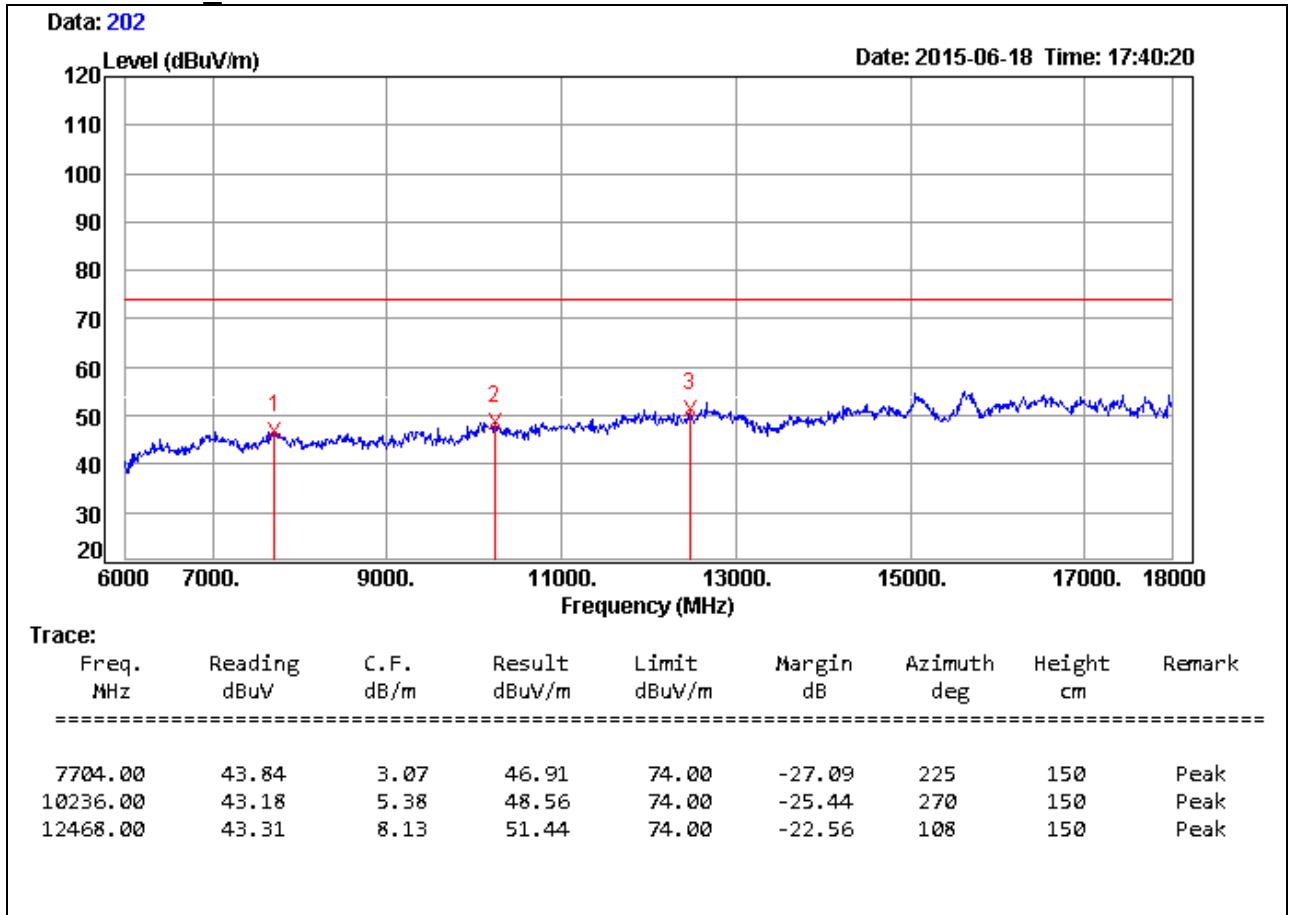

**Remark:**

1. Measuring frequencies from 1 GHz to the 10th harmonic of highest fundamental frequency.
2. Average test would be performed if the peak result were greater than the average limit.
3. Measurements above show only up to 6 maximum emissions noted, or would be lesser, with " N/A " remark, if no specific emissions from the EUT are recorded (ie: margin>20dB from the applicable limit) and considered that's already beyond the background noise floor.
4. Result = Reading + Correction Factor  
Margin = Result - Limit  
Remark Peak = Result(PK) - Limit(PK)  
Remark AVG = Result(AV) - Limit(AV)
5. There is no emission in 18GHz ~ 40GHz.

<b>Product Name</b>	Computer	<b>Test By</b>	Waternil Guan
<b>Test Model</b>	POC127	<b>Test Date</b>	2014/06/22
<b>Test Mode</b>	UNII Band 2C/ IEEE 802.11an HT40 TX / CH Low	<b>Temp. &amp; Humidity</b>	26°C, 52%

966 Chamber\_C at 3Meter / Vertical

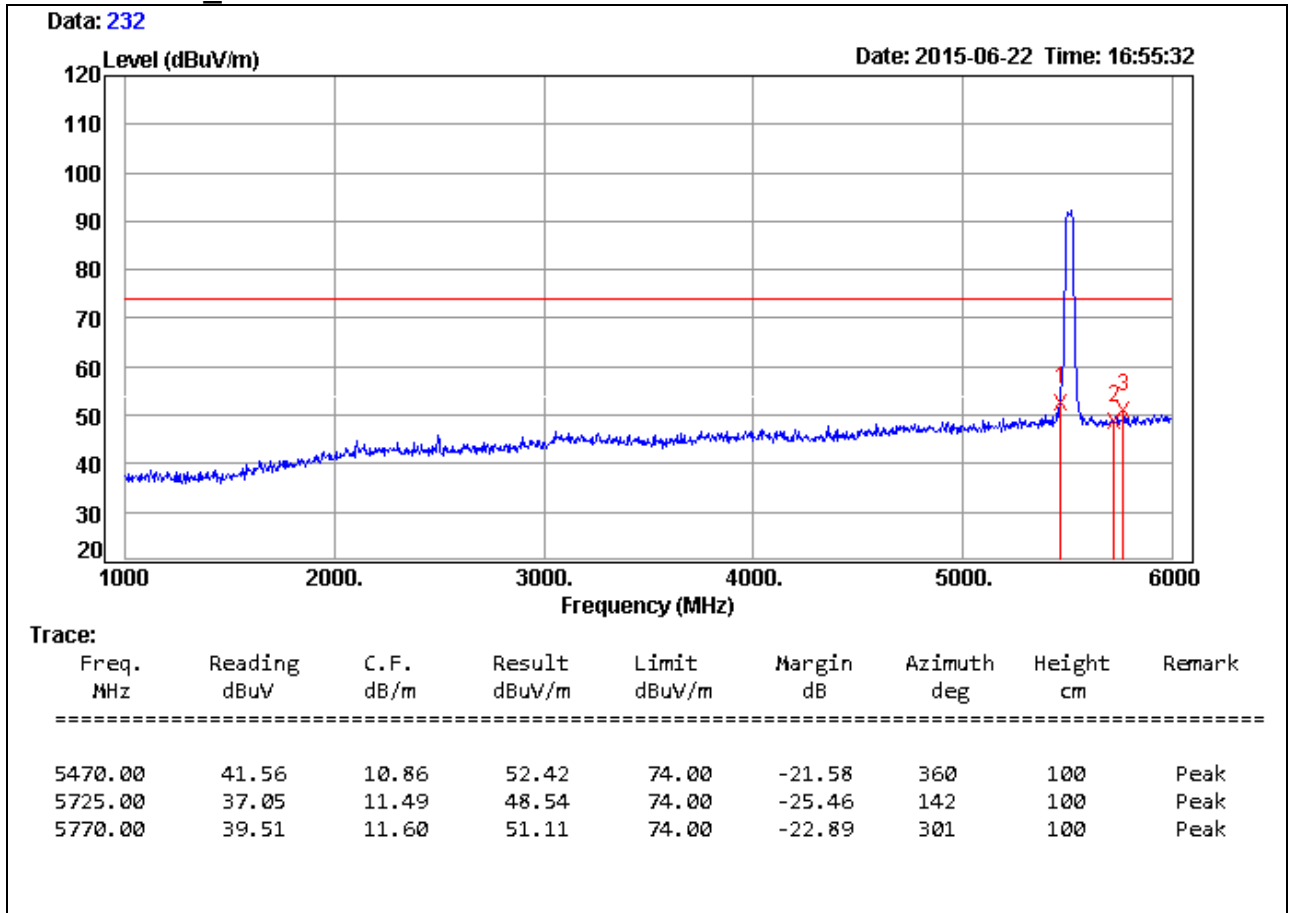

**Remark:**

1. Measuring frequencies from 1 GHz to the 10th harmonic of highest fundamental frequency.
2. Average test would be performed if the peak result were greater than the average limit.
3. Measurements above show only up to 6 maximum emissions noted, or would be lesser, with " N/A " remark, if no specific emissions from the EUT are recorded (ie: margin>20dB from the applicable limit) and considered that's already beyond the background noise floor.
4. Result = Reading + Correction Factor  
 Margin = Result - Limit  
 Remark Peak = Result(PK) - Limit(PK)  
 Remark AVG = Result(AV) - Limit(AV)

<b>Product Name</b>	Computer	<b>Test By</b>	Waternil Guan
<b>Test Model</b>	POC127	<b>Test Date</b>	2015/06/18
<b>Test Mode</b>	UNII Band 2C/ IEEE 802.11an HT40 TX / CH Low	<b>Temp. &amp; Humidity</b>	26°C, 52%

966 Chamber\_C at 3Meter / Vertical

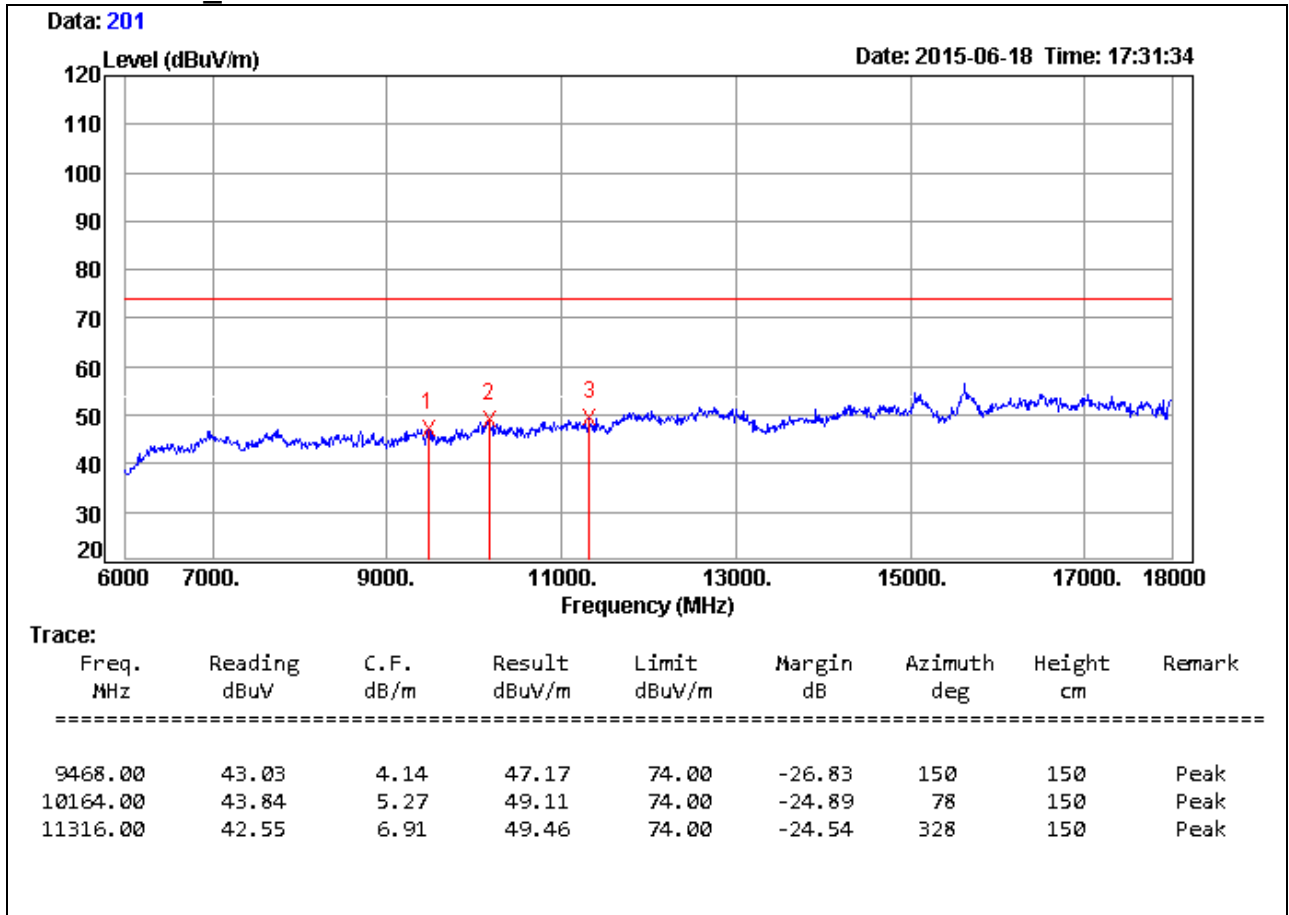

**Remark:**

1. Measuring frequencies from 1 GHz to the 10th harmonic of highest fundamental frequency.
2. Average test would be performed if the peak result were greater than the average limit.
3. Measurements above show only up to 6 maximum emissions noted, or would be lesser, with " N/A " remark, if no specific emissions from the EUT are recorded (ie: margin>20dB from the applicable limit) and considered that's already beyond the background noise floor.
4.  $Result = Reading + Correction\ Factor$   
 $Margin = Result - Limit$   
 $Remark\ Peak = Result(PK) - Limit(PK)$   
 $Remark\ AVG = Result(AV) - Limit(AV)$
5. There is no emission in 18GHz ~ 40GHz.

<b>Product Name</b>	Computer	<b>Test By</b>	Waternil Guan
<b>Test Model</b>	POC127	<b>Test Date</b>	2015/06/22
<b>Test Mode</b>	UNII Band 2C/ IEEE 802.11an HT40 TX / CH Middle	<b>Temp. &amp; Humidity</b>	26°C, 52%

966 Chamber\_C at 3Meter / Horizontal

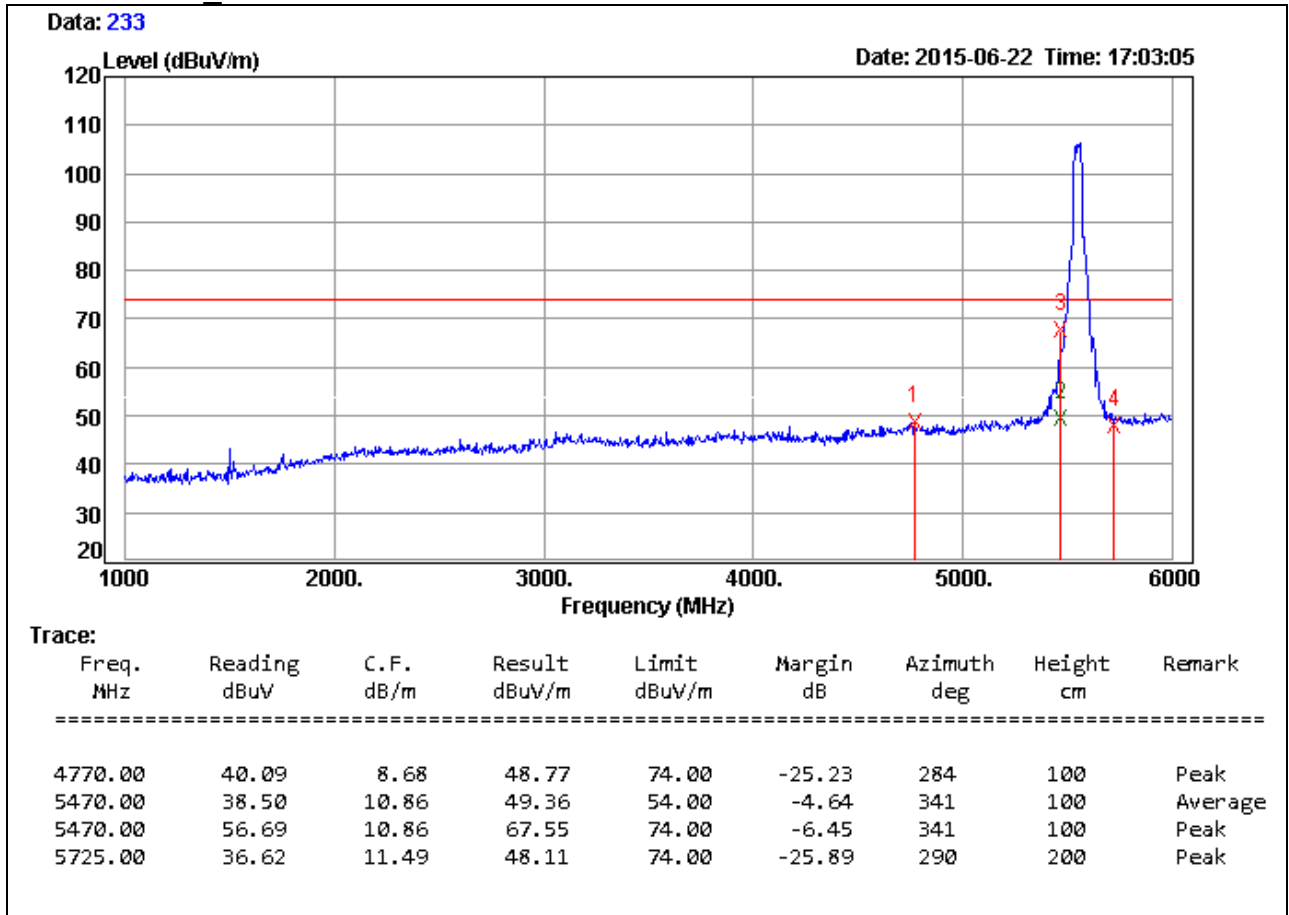

**Remark:**

1. Measuring frequencies from 1 GHz to the 10th harmonic of highest fundamental frequency.
2. Average test would be performed if the peak result were greater than the average limit.
3. Measurements above show only up to 6 maximum emissions noted, or would be lesser, with " N/A " remark, if no specific emissions from the EUT are recorded (ie: margin>20dB from the applicable limit) and considered that's already beyond the background noise floor.
4. Result = Reading + Correction Factor  
 Margin = Result - Limit  
 Remark Peak = Result(PK) - Limit(PK)  
 Remark AVG = Result(AV) - Limit(AV)

<b>Product Name</b>	Computer	<b>Test By</b>	Waternil Guan
<b>Test Model</b>	POC127	<b>Test Date</b>	2015/06/18
<b>Test Mode</b>	UNII Band 2C/ IEEE 802.11an HT40 TX / CH Middle	<b>Temp. &amp; Humidity</b>	26°C, 52%

966 Chamber\_C at 3Meter / Horizontal

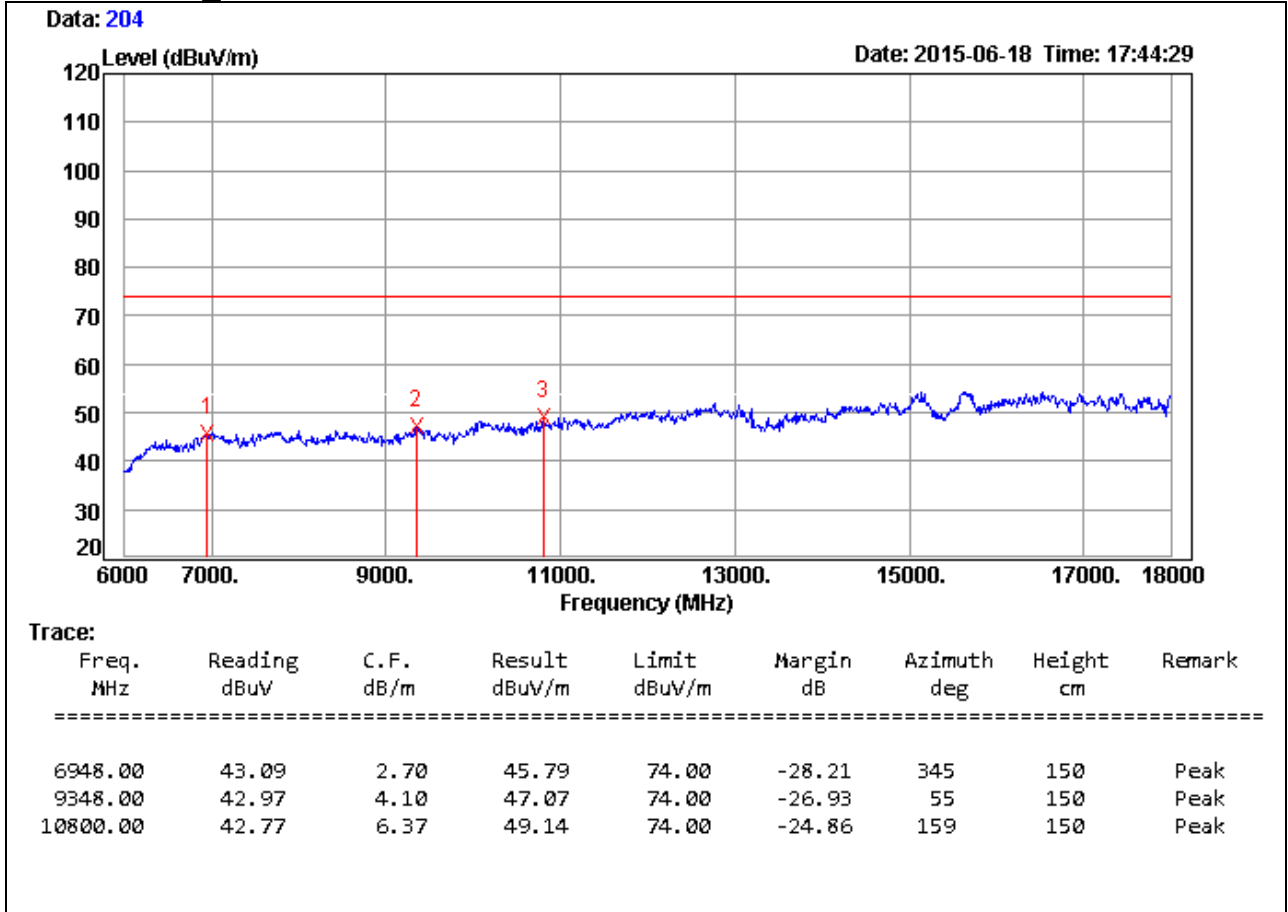

**Remark:**

1. Measuring frequencies from 1 GHz to the 10th harmonic of highest fundamental frequency.
2. Average test would be performed if the peak result were greater than the average limit.
3. Measurements above show only up to 6 maximum emissions noted, or would be lesser, with " N/A " remark, if no specific emissions from the EUT are recorded (ie: margin>20dB from the applicable limit) and considered that's already beyond the background noise floor.
4. Result = Reading + Correction Factor  
Margin = Result - Limit  
Remark Peak = Result(PK) - Limit(PK)  
Remark AVG = Result(AV) - Limit(AV)
5. There is no emission in 18GHz ~ 40GHz.

<b>Product Name</b>	Computer	<b>Test By</b>	Waternil Guan
<b>Test Model</b>	POC127	<b>Test Date</b>	2015/06/22
<b>Test Mode</b>	UNII Band 2C/ IEEE 802.11an HT40 TX / CH Middle	<b>Temp. &amp; Humidity</b>	26°C, 52%

966 Chamber\_C at 3Meter / Vertical

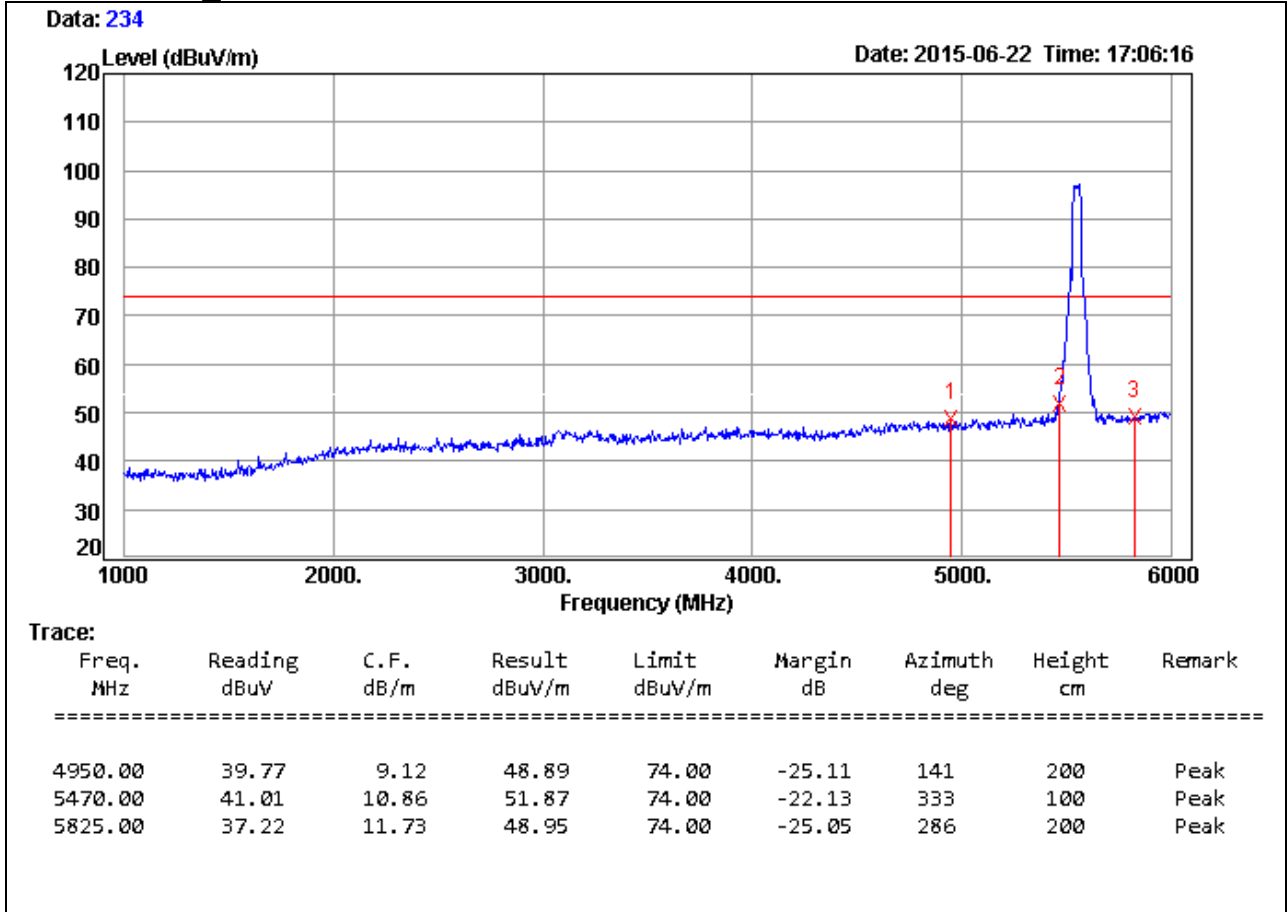

**Remark:**

1. Measuring frequencies from 1 GHz to the 10th harmonic of highest fundamental frequency.
2. Average test would be performed if the peak result were greater than the average limit.
3. Measurements above show only up to 6 maximum emissions noted, or would be lesser, with " N/A " remark, if no specific emissions from the EUT are recorded (ie: margin>20dB from the applicable limit) and considered that's already beyond the background noise floor.
4.  $Result = Reading + Correction\ Factor$   
 $Margin = Result - Limit$   
 $Remark\ Peak = Result(PK) - Limit(PK)$   
 $Remark\ AVG = Result(AV) - Limit(AV)$

<b>Product Name</b>	Computer	<b>Test By</b>	Watnail Guan
<b>Test Model</b>	POC127	<b>Test Date</b>	2015/06/18
<b>Test Mode</b>	UNII Band 2C/ IEEE 802.11an HT40 TX / CH Middle	<b>Temp. &amp; Humidity</b>	26°C, 52%

966 Chamber\_C at 3Meter / Vertical

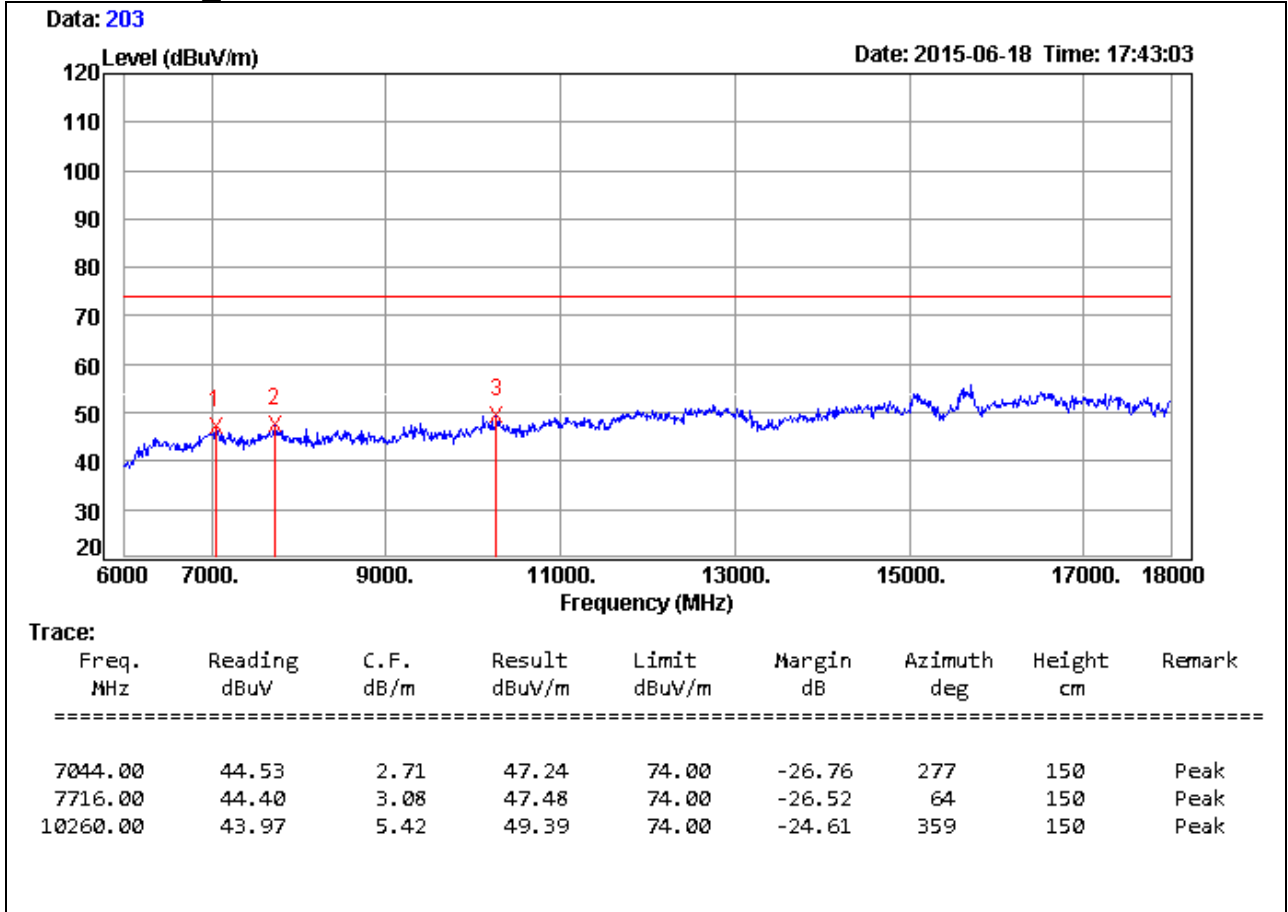

**Remark:**

1. Measuring frequencies from 1 GHz to the 10th harmonic of highest fundamental frequency.
2. Average test would be performed if the peak result were greater than the average limit.
3. Measurements above show only up to 6 maximum emissions noted, or would be lesser, with " N/A " remark, if no specific emissions from the EUT are recorded (ie: margin>20dB from the applicable limit) and considered that's already beyond the background noise floor.
4.  $Result = Reading + Correction\ Factor$   
 $Margin = Result - Limit$   
 $Remark\ Peak = Result(PK) - Limit(PK)$   
 $Remark\ AVG = Result(AV) - Limit(AV)$
5. There is no emission in 18GHz ~ 40GHz.

<b>Product Name</b>	Computer	<b>Test By</b>	Waternil Guan
<b>Test Model</b>	POC127	<b>Test Date</b>	2015/06/22
<b>Test Mode</b>	UNII Band 2C/ IEEE 802.11an HT40 TX / CH High	<b>Temp. &amp; Humidity</b>	26°C, 52%

966 Chamber\_C at 3Meter / Horizontal

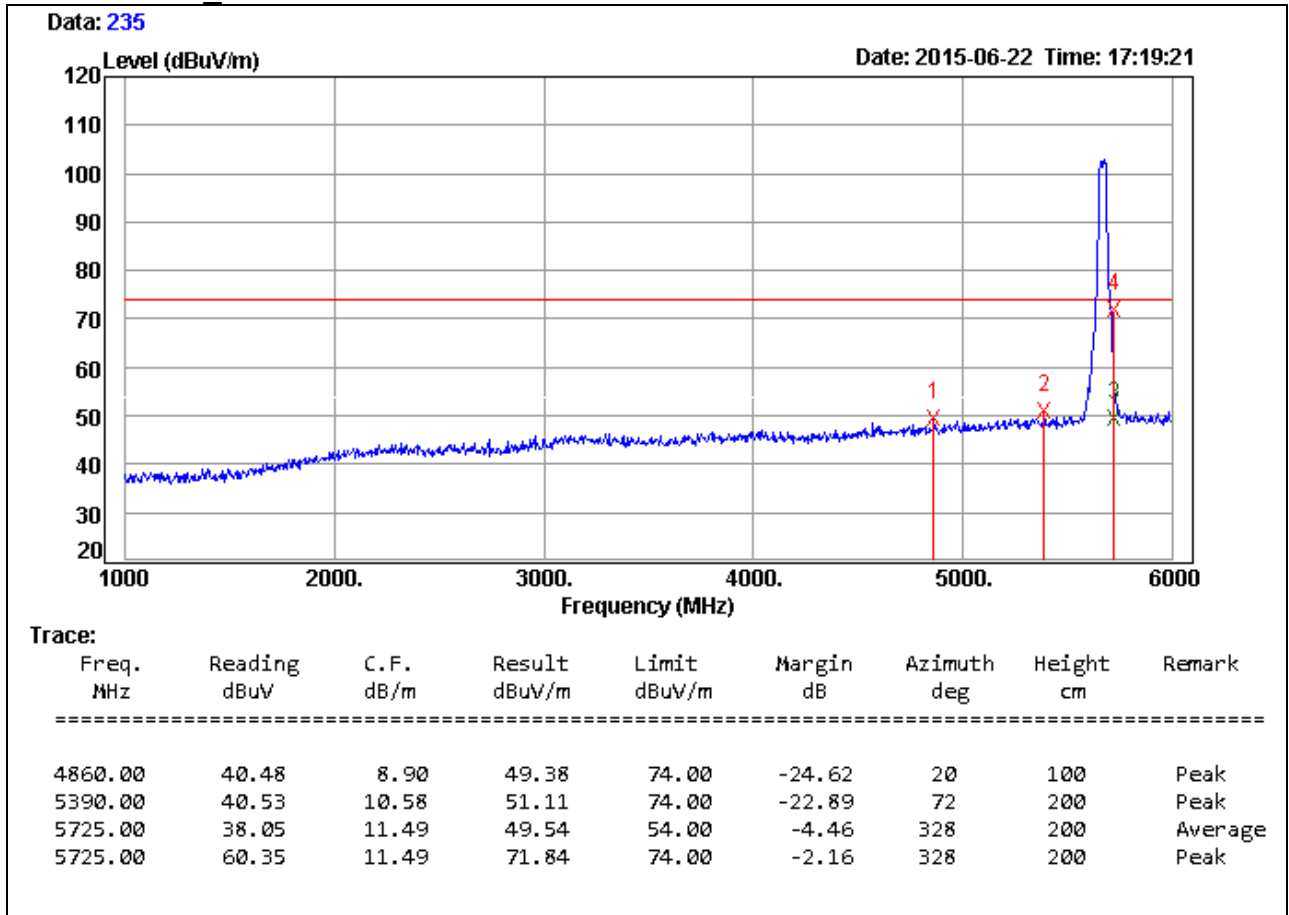

**Remark:**

1. Measuring frequencies from 1 GHz to the 10th harmonic of highest fundamental frequency.
2. Average test would be performed if the peak result were greater than the average limit.
3. Measurements above show only up to 6 maximum emissions noted, or would be lesser, with " N/A " remark, if no specific emissions from the EUT are recorded (ie: margin>20dB from the applicable limit) and considered that's already beyond the background noise floor.
4. Result = Reading + Correction Factor  
 Margin = Result - Limit  
 Remark Peak = Result(PK) - Limit(PK)  
 Remark AVG = Result(AV) - Limit(AV)



<b>Product Name</b>	Computer	<b>Test By</b>	Waternil Guan
<b>Test Model</b>	POC127	<b>Test Date</b>	2015/06/18
<b>Test Mode</b>	UNII Band 2C/ IEEE 802.11an HT40 TX / CH High	<b>Temp. &amp; Humidity</b>	26°C, 52%

966 Chamber\_C at 3Meter / Horizontal

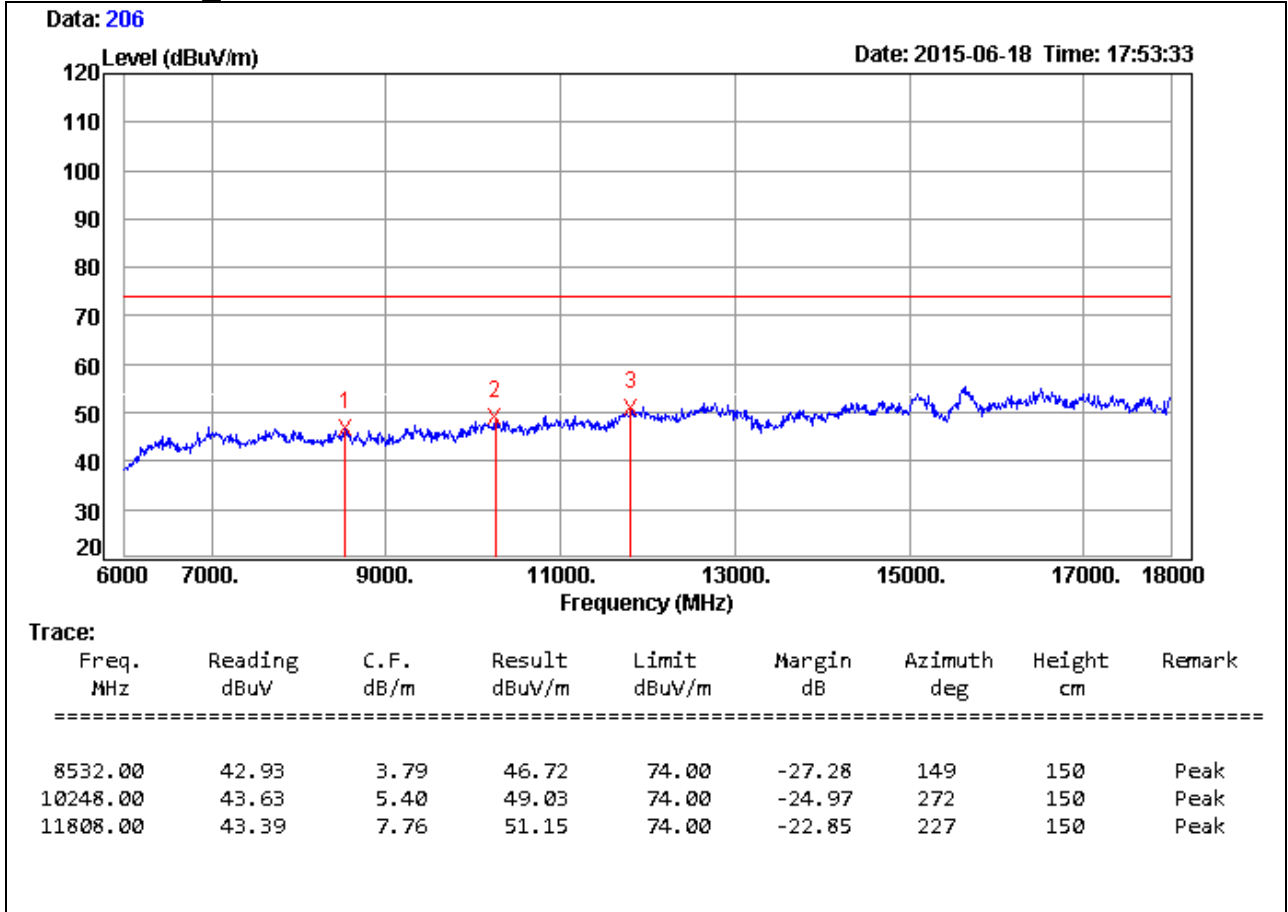

**Remark:**

1. Measuring frequencies from 1 GHz to the 10th harmonic of highest fundamental frequency.
2. Average test would be performed if the peak result were greater than the average limit.
3. Measurements above show only up to 6 maximum emissions noted, or would be lesser, with " N/A " remark, if no specific emissions from the EUT are recorded (ie: margin>20dB from the applicable limit) and considered that's already beyond the background noise floor.
4. Result = Reading + Correction Factor  
Margin = Result - Limit  
Remark Peak = Result(PK) - Limit(PK)  
Remark AVG = Result(AV) - Limit(AV)
5. There is no emission in 18GHz ~ 40GHz.

<b>Product Name</b>	Computer	<b>Test By</b>	Waternil Guan
<b>Test Model</b>	POC127	<b>Test Date</b>	2015/06/22
<b>Test Mode</b>	UNII Band 2C/ IEEE 802.11an HT40 TX / CH High	<b>Temp. &amp; Humidity</b>	26°C, 52%

966 Chamber\_C at 3Meter / Vertical

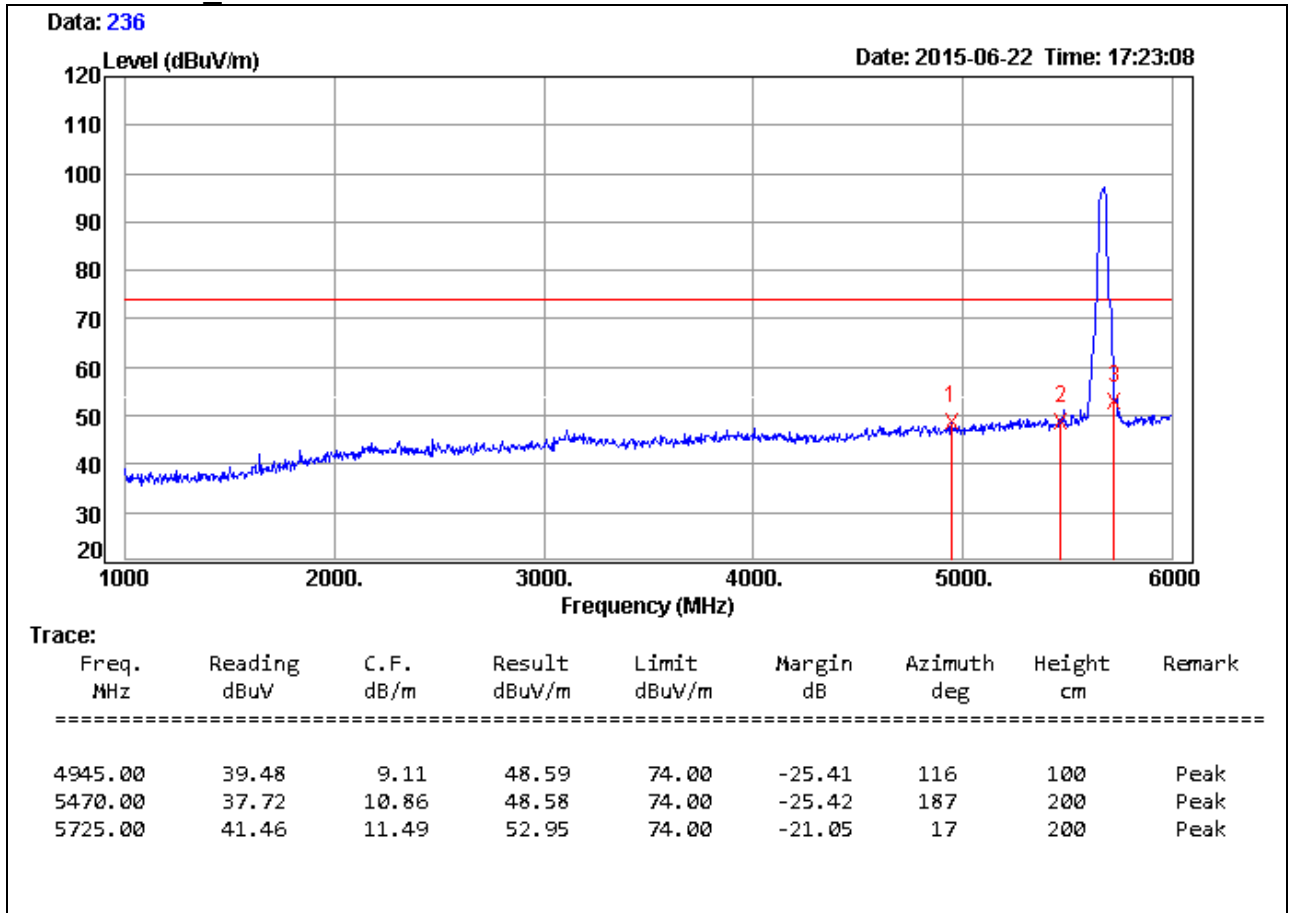

**Remark:**

1. Measuring frequencies from 1 GHz to the 10th harmonic of highest fundamental frequency.
2. Average test would be performed if the peak result were greater than the average limit.
3. Measurements above show only up to 6 maximum emissions noted, or would be lesser, with " N/A " remark, if no specific emissions from the EUT are recorded (ie: margin>20dB from the applicable limit) and considered that's already beyond the background noise floor.
4. Result = Reading + Correction Factor  
 Margin = Result - Limit  
 Remark Peak = Result(PK) - Limit(PK)  
 Remark AVG = Result(AV) - Limit(AV)

<b>Product Name</b>	Computer	<b>Test By</b>	Waternil Guan
<b>Test Model</b>	POC127	<b>Test Date</b>	2015/06/18
<b>Test Mode</b>	UNII Band 2C/ IEEE 802.11an HT40 TX / CH High	<b>Temp. &amp; Humidity</b>	26°C, 52%

966 Chamber\_C at 3Meter / Vertical

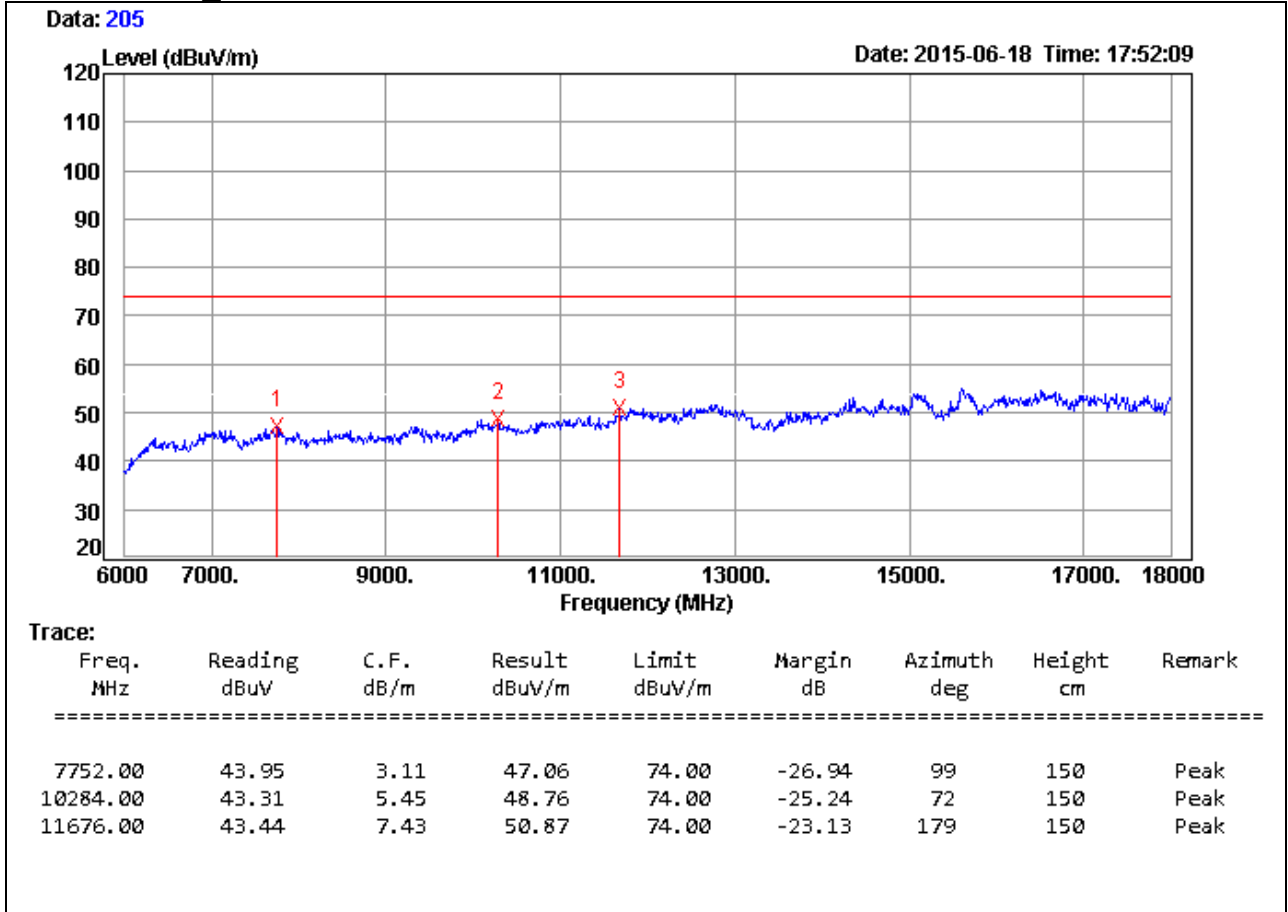

**Remark:**

1. Measuring frequencies from 1 GHz to the 10th harmonic of highest fundamental frequency.
2. Average test would be performed if the peak result were greater than the average limit.
3. Measurements above show only up to 6 maximum emissions noted, or would be lesser, with " N/A " remark, if no specific emissions from the EUT are recorded (ie: margin>20dB from the applicable limit) and considered that's already beyond the background noise floor.
4.  $Result = Reading + Correction\ Factor$   
 $Margin = Result - Limit$   
 $Remark\ Peak = Result(PK) - Limit(PK)$   
 $Remark\ AVG = Result(AV) - Limit(AV)$
5. There is no emission in 18GHz ~ 40GHz.

<b>Product Name</b>	Computer	<b>Test By</b>	Waternil Guan
<b>Test Model</b>	POC127	<b>Test Date</b>	2015/06/08
<b>Test Mode</b>	UNII Band 3/ IEEE 802.11a TX / CH Low	<b>Temp. &amp; Humidity</b>	26°C, 52%

966 Chamber\_C at 3Meter / Horizontal

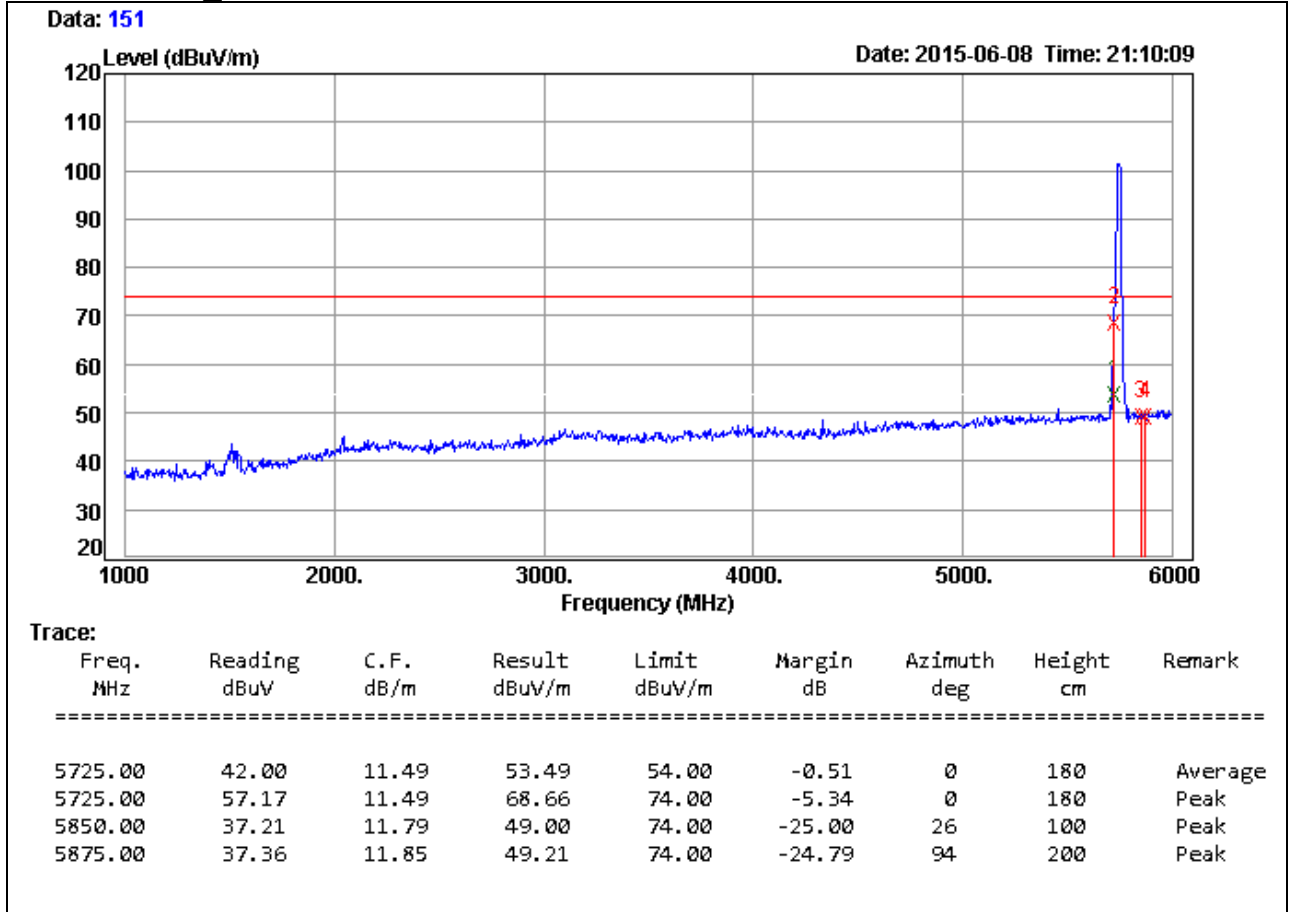

**Remark:**

1. Measuring frequencies from 1 GHz to the 10th harmonic of highest fundamental frequency.
2. Average test would be performed if the peak result were greater than the average limit.
3. Measurements above show only up to 6 maximum emissions noted, or would be lesser, with " N/A " remark, if no specific emissions from the EUT are recorded (ie: margin>20dB from the applicable limit) and considered that's already beyond the background noise floor.
4.  $Result = Reading + Correction\ Factor$   
 $Margin = Result - Limit$   
 $Remark\ Peak = Result(PK) - Limit(PK)$   
 $Remark\ AVG = Result(AV) - Limit(AV)$

<b>Product Name</b>	Computer	<b>Test By</b>	Waternil Guan
<b>Test Model</b>	POC127	<b>Test Date</b>	2015/06/05
<b>Test Mode</b>	UNII Band 3/ IEEE 802.11a TX / CH Low	<b>Temp. &amp; Humidity</b>	26°C, 52%

966 Chamber\_C at 3Meter / Horizontal

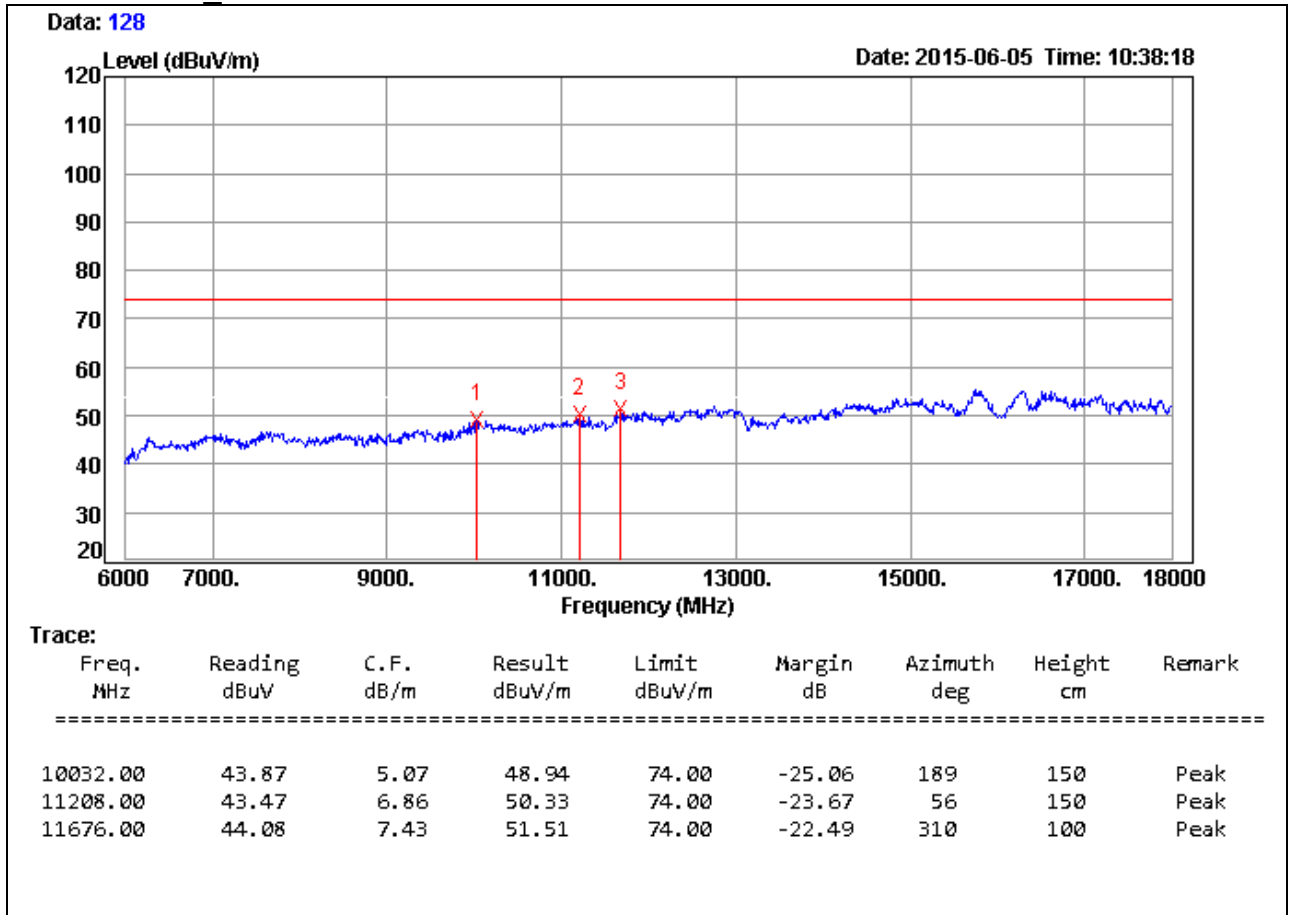

**Remark:**

1. Measuring frequencies from 1 GHz to the 10th harmonic of highest fundamental frequency.
2. Average test would be performed if the peak result were greater than the average limit.
3. Measurements above show only up to 6 maximum emissions noted, or would be lesser, with " N/A " remark, if no specific emissions from the EUT are recorded (ie: margin>20dB from the applicable limit) and considered that's already beyond the background noise floor.
4. Result = Reading + Correction Factor  
Margin = Result - Limit  
Remark Peak = Result(PK) - Limit(PK)  
Remark AVG = Result(AV) - Limit(AV)
5. There is no emission in 18GHz ~ 40GHz.

<b>Product Name</b>	Computer	<b>Test By</b>	Waternil Guan
<b>Test Model</b>	POC127	<b>Test Date</b>	2015/06/08
<b>Test Mode</b>	UNII Band 3/ IEEE 802.11a TX / CH Low	<b>Temp. &amp; Humidity</b>	26°C, 52%

966 Chamber\_C at 3Meter / Vertical

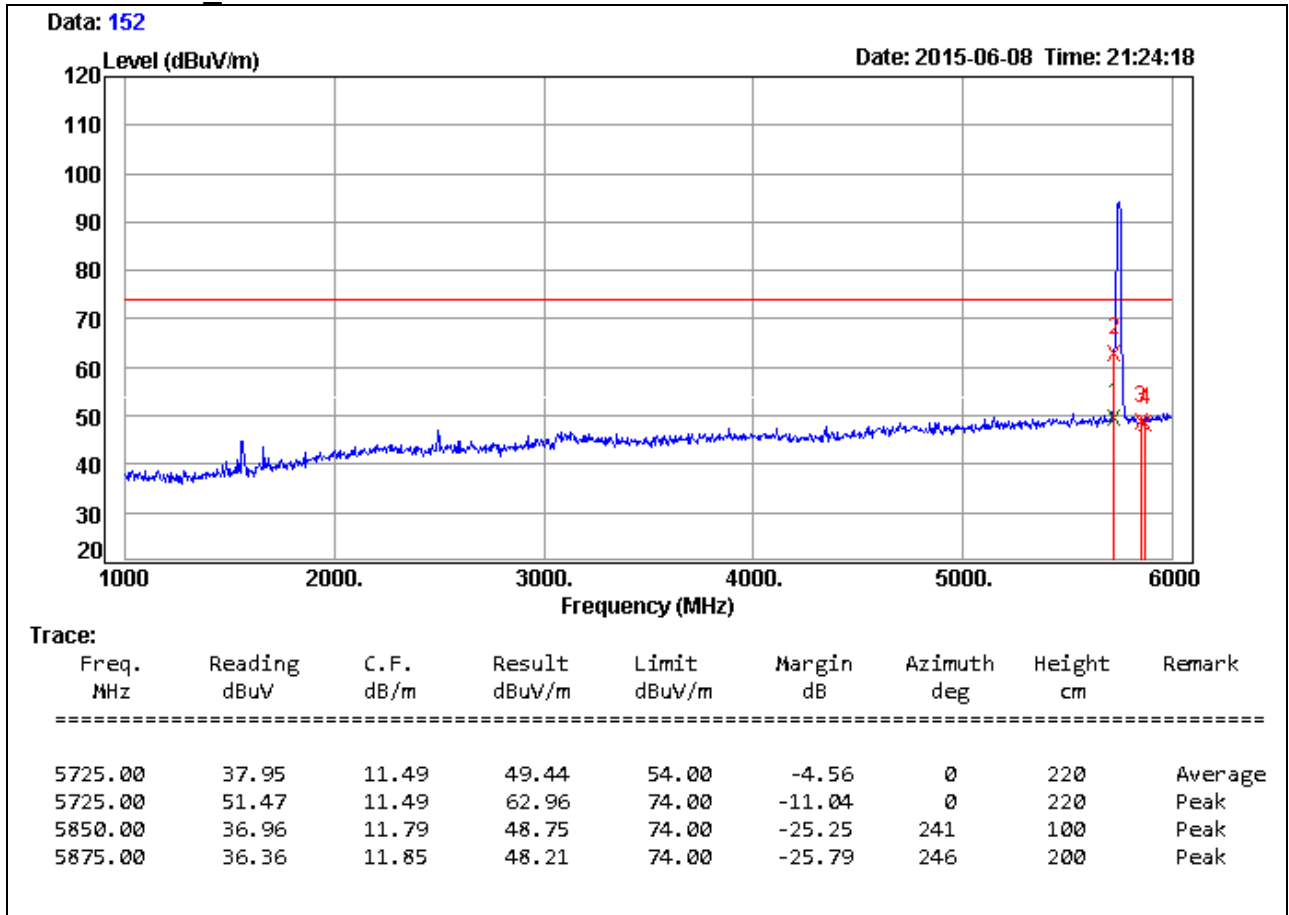

**Remark:**

1. Measuring frequencies from 1 GHz to the 10th harmonic of highest fundamental frequency.
2. Average test would be performed if the peak result were greater than the average limit.
3. Measurements above show only up to 6 maximum emissions noted, or would be lesser, with " N/A " remark, if no specific emissions from the EUT are recorded (ie: margin>20dB from the applicable limit) and considered that's already beyond the background noise floor.
4.  $Result = Reading + Correction\ Factor$   
 $Margin = Result - Limit$   
 $Remark\ Peak = Result(PK) - Limit(PK)$   
 $Remark\ AVG = Result(AV) - Limit(AV)$

<b>Product Name</b>	Computer	<b>Test By</b>	Waternil Guan
<b>Test Model</b>	POC127	<b>Test Date</b>	2015/06/05
<b>Test Mode</b>	UNII Band 3/ IEEE 802.11a TX / CH Low	<b>Temp. &amp; Humidity</b>	26°C, 52%

966 Chamber\_C at 3Meter / Vertical

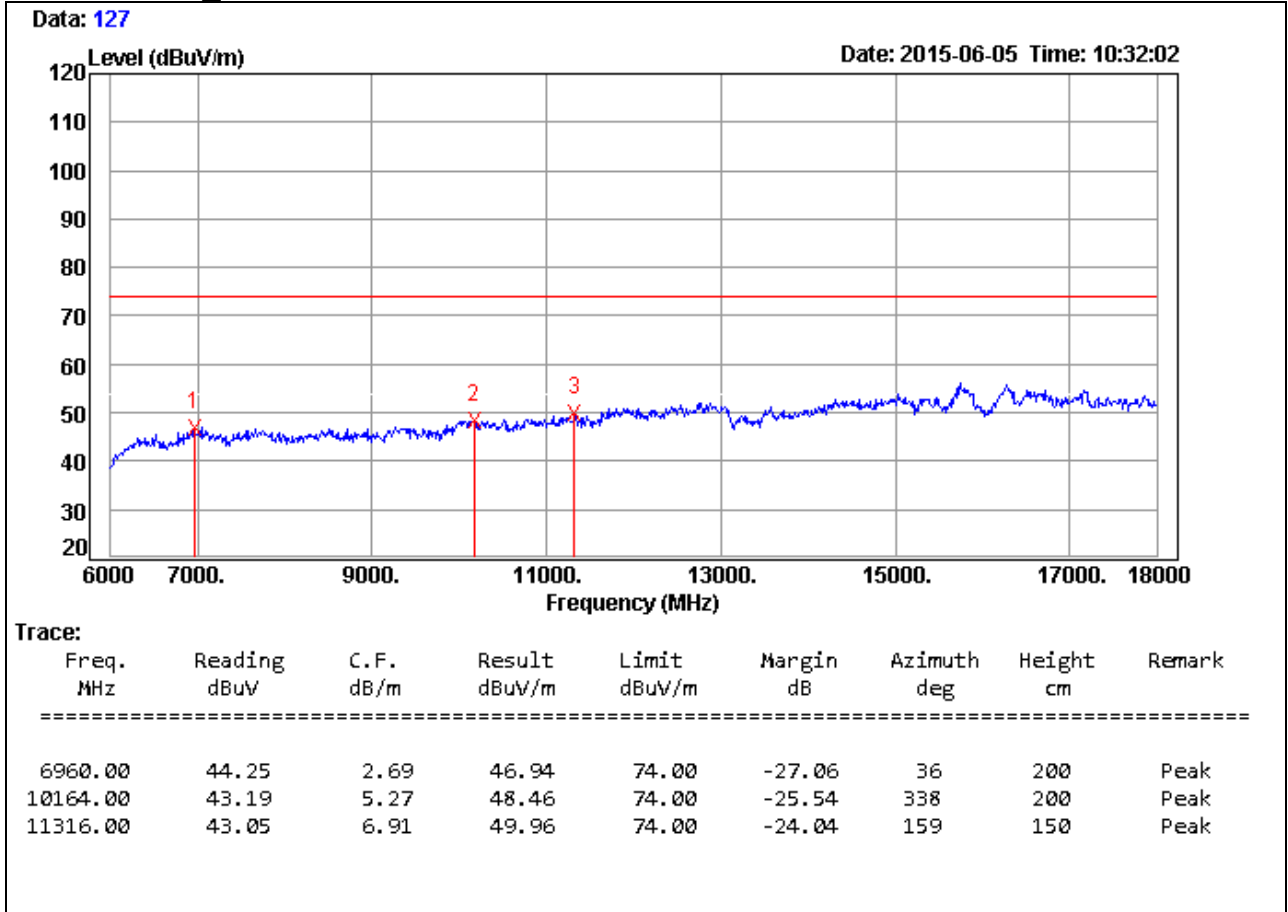

**Remark:**

1. Measuring frequencies from 1 GHz to the 10th harmonic of highest fundamental frequency.
2. Average test would be performed if the peak result were greater than the average limit.
3. Measurements above show only up to 6 maximum emissions noted, or would be lesser, with " N/A " remark, if no specific emissions from the EUT are recorded (ie: margin>20dB from the applicable limit) and considered that's already beyond the background noise floor.
4.  $Result = Reading + Correction\ Factor$   
 $Margin = Result - Limit$   
 $Remark\ Peak = Result(PK) - Limit(PK)$   
 $Remark\ AVG = Result(AV) - Limit(AV)$
5. There is no emission in 18GHz ~ 40GHz.

<b>Product Name</b>	Computer	<b>Test By</b>	Waternil Guan
<b>Test Model</b>	POC127	<b>Test Date</b>	2015/06/08
<b>Test Mode</b>	UNII Band 3/ IEEE 802.11a TX / CH Middle	<b>Temp. &amp; Humidity</b>	26°C, 52%

966 Chamber\_C at 3Meter / Horizontal

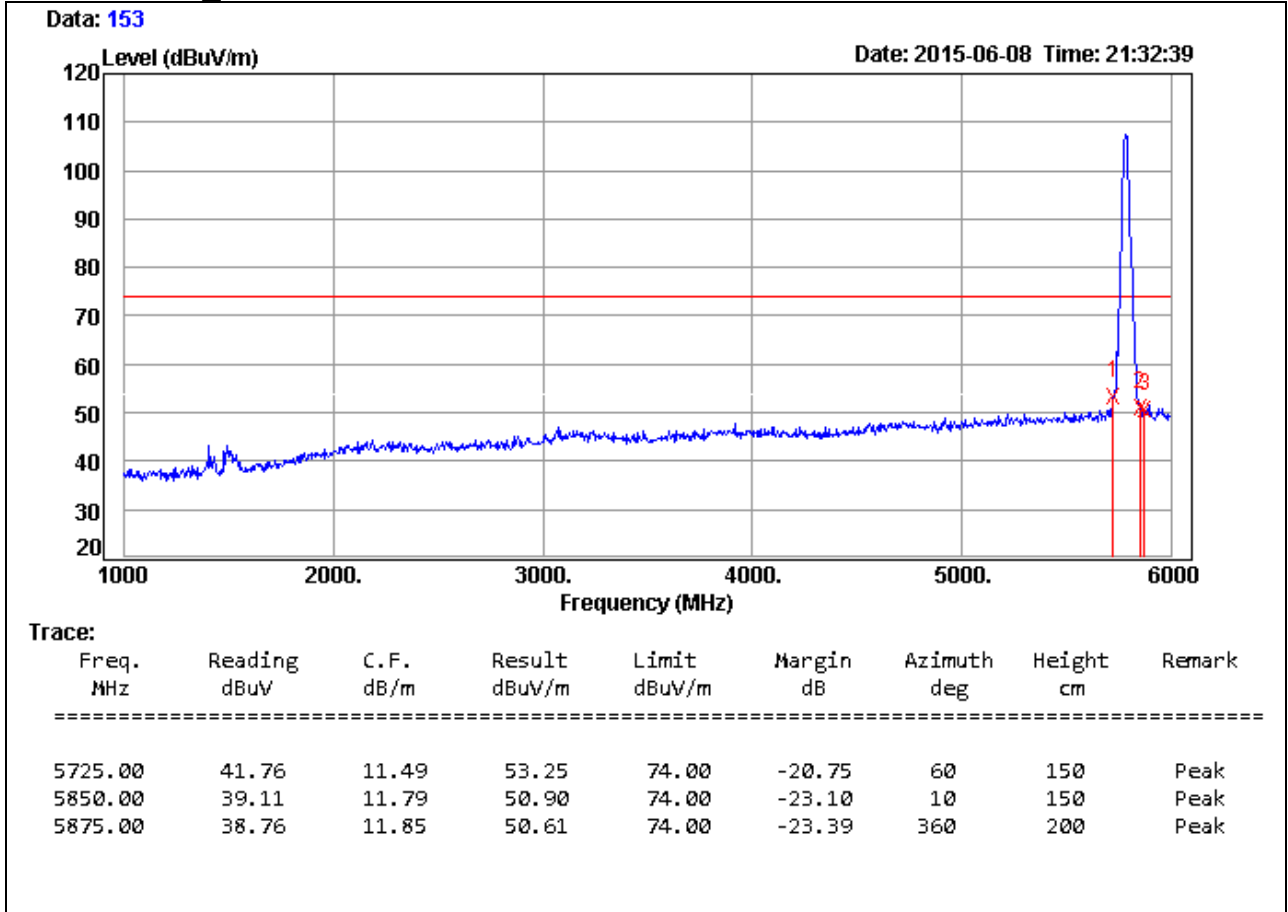

**Remark:**

1. Measuring frequencies from 1 GHz to the 10th harmonic of highest fundamental frequency.
2. Average test would be performed if the peak result were greater than the average limit.
3. Measurements above show only up to 6 maximum emissions noted, or would be lesser, with " N/A " remark, if no specific emissions from the EUT are recorded (ie: margin>20dB from the applicable limit) and considered that's already beyond the background noise floor.
4.  $Result = Reading + Correction\ Factor$   
 $Margin = Result - Limit$   
 $Remark\ Peak = Result(PK) - Limit(PK)$   
 $Remark\ AVG = Result(AV) - Limit(AV)$



<b>Product Name</b>	Computer	<b>Test By</b>	Waternil Guan
<b>Test Model</b>	POC127	<b>Test Date</b>	2015/06/05
<b>Test Mode</b>	UNII Band 3/ IEEE 802.11a TX / CH Middle	<b>Temp. &amp; Humidity</b>	26°C, 52%

966 Chamber\_C at 3Meter / Horizontal

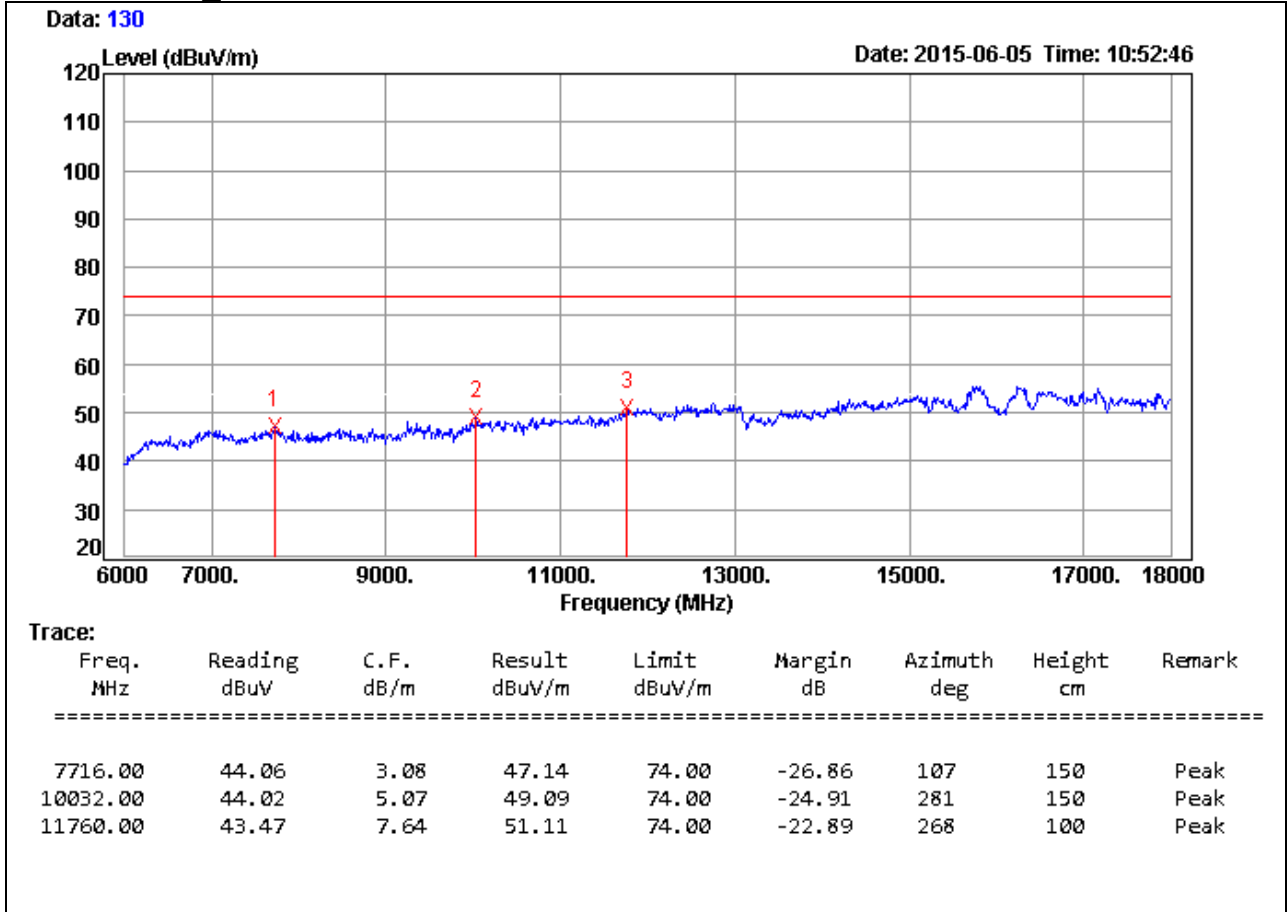

**Remark:**

1. Measuring frequencies from 1 GHz to the 10th harmonic of highest fundamental frequency.
2. Average test would be performed if the peak result were greater than the average limit.
3. Measurements above show only up to 6 maximum emissions noted, or would be lesser, with " N/A " remark, if no specific emissions from the EUT are recorded (ie: margin>20dB from the applicable limit) and considered that's already beyond the background noise floor.
4. Result = Reading + Correction Factor  
 Margin = Result - Limit  
 Remark Peak = Result(PK) - Limit(PK)  
 Remark AVG = Result(AV) - Limit(AV)
5. There is no emission in 18GHz ~ 40GHz.

<b>Product Name</b>	Computer	<b>Test By</b>	Waternil Guan
<b>Test Model</b>	POC127	<b>Test Date</b>	2015/06/08
<b>Test Mode</b>	UNII Band 3/ IEEE 802.11a TX / CH Middle	<b>Temp. &amp; Humidity</b>	26°C, 52%

966 Chamber\_C at 3Meter / Vertical

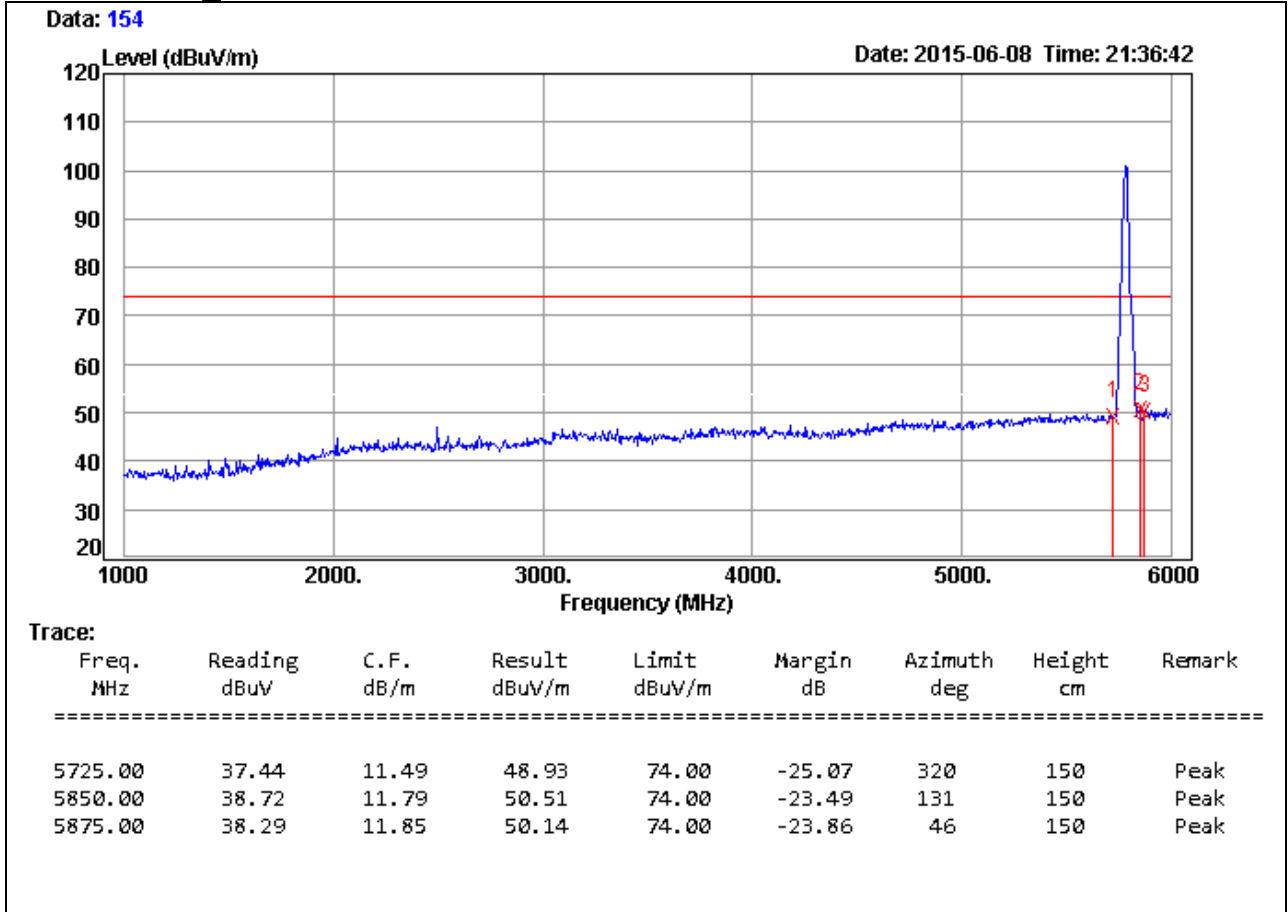

**Remark:**

1. Measuring frequencies from 1 GHz to the 10th harmonic of highest fundamental frequency.
2. Average test would be performed if the peak result were greater than the average limit.
3. Measurements above show only up to 6 maximum emissions noted, or would be lesser, with " N/A " remark, if no specific emissions from the EUT are recorded (ie: margin>20dB from the applicable limit) and considered that's already beyond the background noise floor.
4.  $Result = Reading + Correction\ Factor$   
 $Margin = Result - Limit$   
 $Remark\ Peak = Result(PK) - Limit(PK)$   
 $Remark\ AVG = Result(AV) - Limit(AV)$

<b>Product Name</b>	Computer	<b>Test By</b>	Waternil Guan
<b>Test Model</b>	POC127	<b>Test Date</b>	2015/06/05
<b>Test Mode</b>	UNII Band 3/ IEEE 802.11a TX / CH Middle	<b>Temp. &amp; Humidity</b>	26°C, 52%

966 Chamber\_C at 3Meter / Vertical

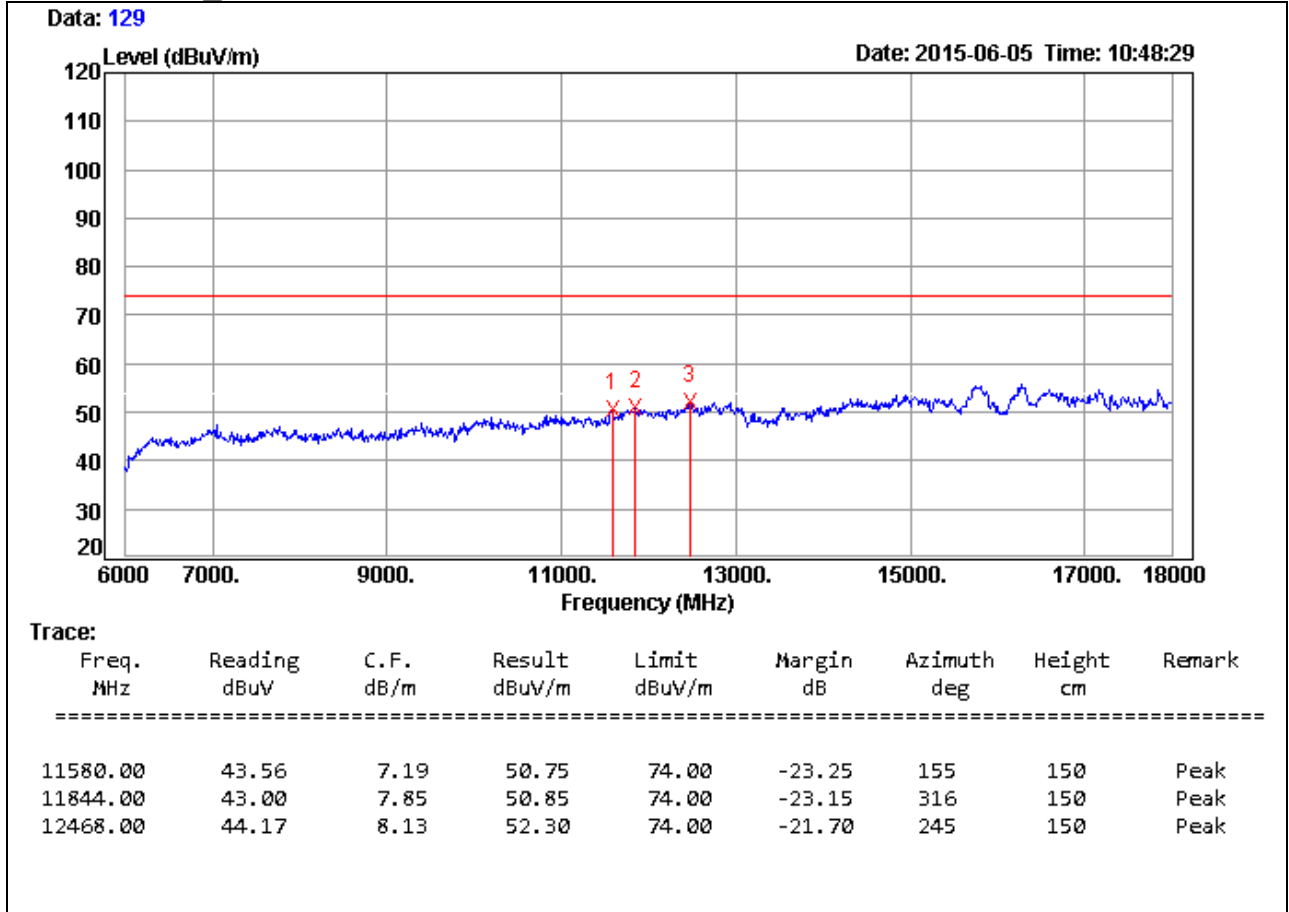

**Remark:**

1. Measuring frequencies from 1 GHz to the 10th harmonic of highest fundamental frequency.
2. Average test would be performed if the peak result were greater than the average limit.
3. Measurements above show only up to 6 maximum emissions noted, or would be lesser, with " N/A " remark, if no specific emissions from the EUT are recorded (ie: margin>20dB from the applicable limit) and considered that's already beyond the background noise floor.
4. Result = Reading + Correction Factor  
Margin = Result - Limit  
Remark Peak = Result(PK) - Limit(PK)  
Remark AVG = Result(AV) - Limit(AV)
5. There is no emission in 18GHz ~ 40GHz.

<b>Product Name</b>	Computer	<b>Test By</b>	Waternil Guan
<b>Test Model</b>	POC127	<b>Test Date</b>	2015/06/08
<b>Test Mode</b>	UNII Band 3/ IEEE 802.11a TX / CH High	<b>Temp. &amp; Humidity</b>	26°C, 52%

966 Chamber\_C at 3Meter / Horizontal

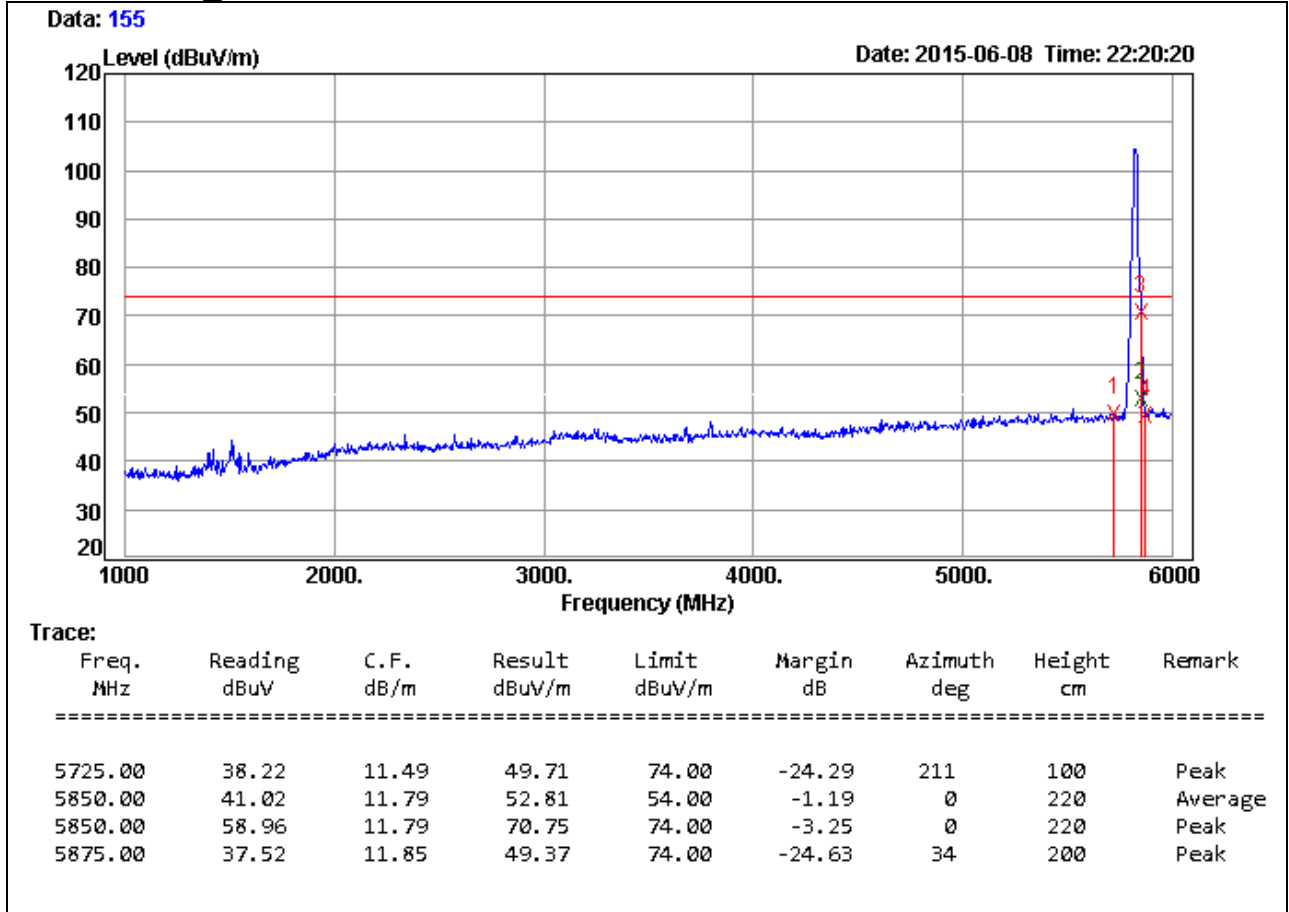

**Remark:**

1. Measuring frequencies from 1 GHz to the 10th harmonic of highest fundamental frequency.
2. Average test would be performed if the peak result were greater than the average limit.
3. Measurements above show only up to 6 maximum emissions noted, or would be lesser, with " N/A " remark, if no specific emissions from the EUT are recorded (ie: margin>20dB from the applicable limit) and considered that's already beyond the background noise floor.
4. Result = Reading + Correction Factor  
 Margin = Result - Limit  
 Remark Peak = Result(PK) - Limit(PK)  
 Remark AVG = Result(AV) - Limit(AV)

<b>Product Name</b>	Computer	<b>Test By</b>	Watniril Guan
<b>Test Model</b>	POC127	<b>Test Date</b>	2015/06/05
<b>Test Mode</b>	UNII Band 3/ IEEE 802.11a TX / CH High	<b>Temp. &amp; Humidity</b>	26°C, 52%

966 Chamber\_C at 3Meter / Horizontal

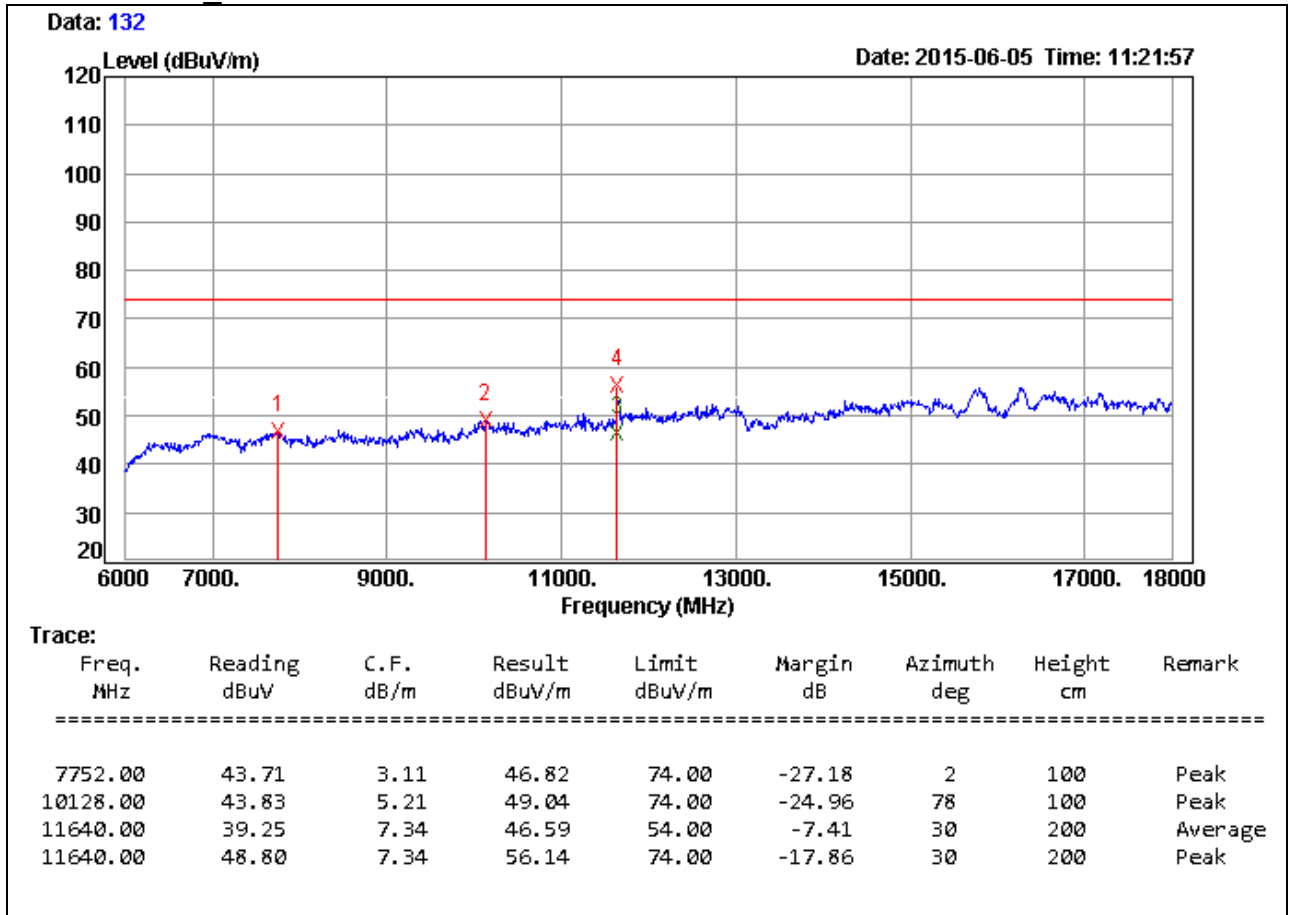

**Remark:**

1. Measuring frequencies from 1 GHz to the 10th harmonic of highest fundamental frequency.
2. Average test would be performed if the peak result were greater than the average limit.
3. Measurements above show only up to 6 maximum emissions noted, or would be lesser, with " N/A " remark, if no specific emissions from the EUT are recorded (ie: margin>20dB from the applicable limit) and considered that's already beyond the background noise floor.
4.  $Result = Reading + Correction\ Factor$   
 $Margin = Result - Limit$   
 $Remark\ Peak = Result(PK) - Limit(PK)$   
 $Remark\ AVG = Result(AV) - Limit(AV)$
5. There is no emission in 18GHz ~ 40GHz.

<b>Product Name</b>	Computer	<b>Test By</b>	Waternil Guan
<b>Test Model</b>	POC127	<b>Test Date</b>	2015/06/08
<b>Test Mode</b>	UNII Band 3/ IEEE 802.11a TX / CH High	<b>Temp. &amp; Humidity</b>	26°C, 52%

966 Chamber\_C at 3Meter / Vertical

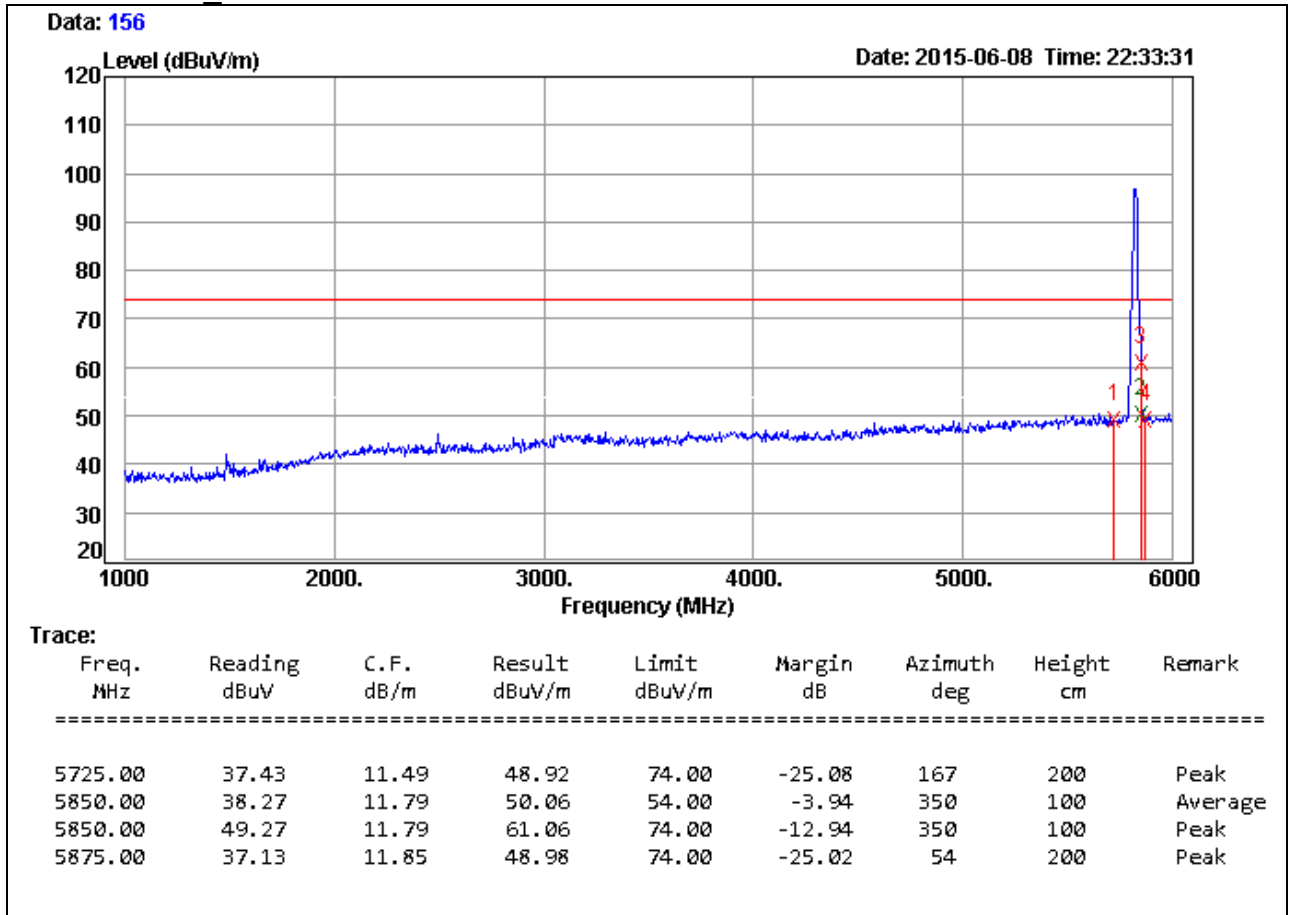

**Remark:**

1. Measuring frequencies from 1 GHz to the 10th harmonic of highest fundamental frequency.
2. Average test would be performed if the peak result were greater than the average limit.
3. Measurements above show only up to 6 maximum emissions noted, or would be lesser, with " N/A " remark, if no specific emissions from the EUT are recorded (ie: margin>20dB from the applicable limit) and considered that's already beyond the background noise floor.
4.  $Result = Reading + Correction\ Factor$   
 $Margin = Result - Limit$   
 $Remark\ Peak = Result(PK) - Limit(PK)$   
 $Remark\ AVG = Result(AV) - Limit(AV)$

<b>Product Name</b>	Computer	<b>Test By</b>	Waternil Guan
<b>Test Model</b>	POC127	<b>Test Date</b>	2015/06/05
<b>Test Mode</b>	UNII Band 3/ IEEE 802.11a TX / CH High	<b>Temp. &amp; Humidity</b>	26°C, 52%

966 Chamber\_C at 3Meter / Vertical

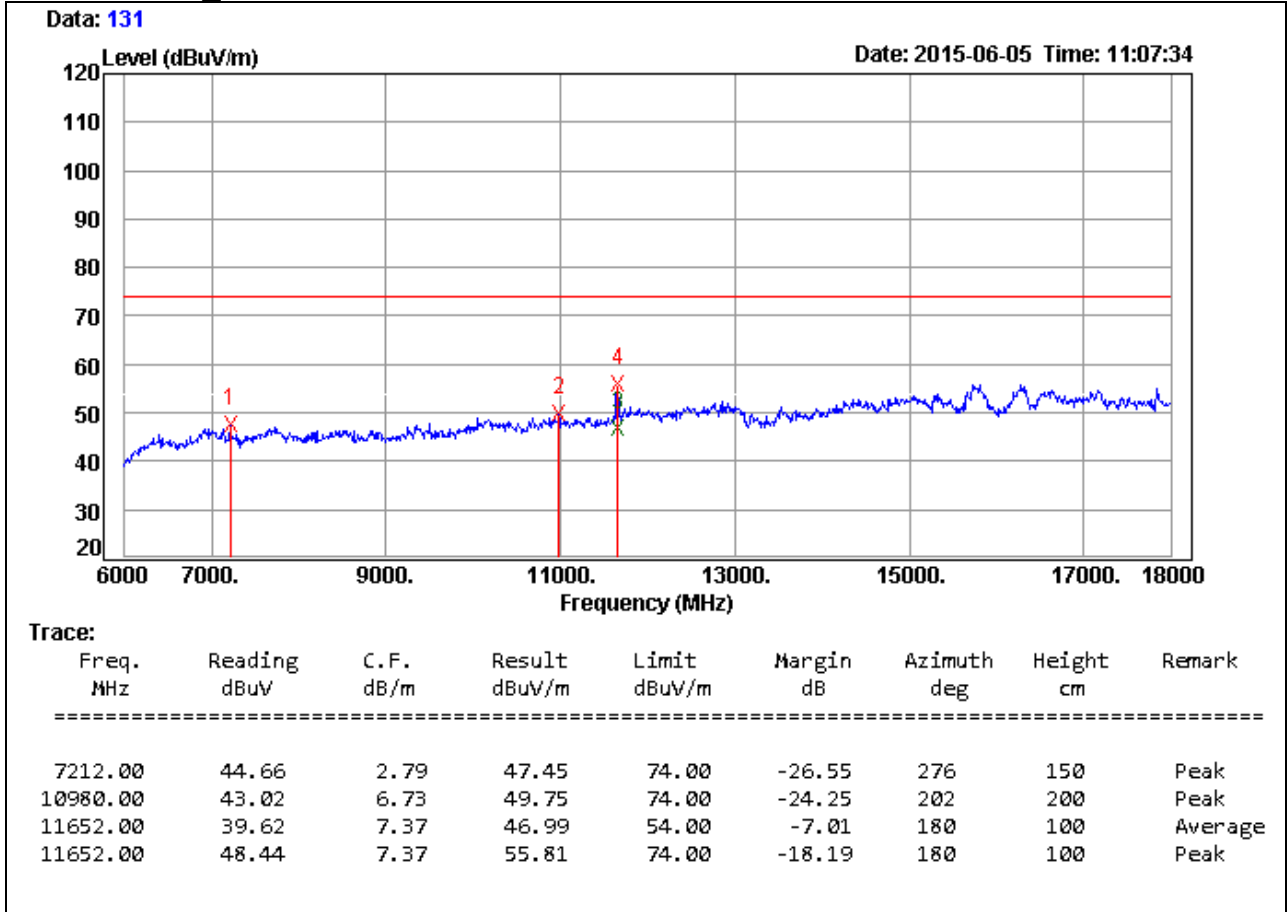

**Remark:**

1. Measuring frequencies from 1 GHz to the 10th harmonic of highest fundamental frequency.
2. Average test would be performed if the peak result were greater than the average limit.
3. Measurements above show only up to 6 maximum emissions noted, or would be lesser, with " N/A " remark, if no specific emissions from the EUT are recorded (ie: margin>20dB from the applicable limit) and considered that's already beyond the background noise floor.
4. Result = Reading + Correction Factor  
 Margin = Result - Limit  
 Remark Peak = Result(PK) - Limit(PK)  
 Remark AVG = Result(AV) - Limit(AV)
5. There is no emission in 18GHz ~ 40GHz.

<b>Product Name</b>	Computer	<b>Test By</b>	Waternil Guan
<b>Test Model</b>	POC127	<b>Test Date</b>	2015/06/22
<b>Test Mode</b>	UNII Band 3/ IEEE 802.11an HT20 TX / CH Low	<b>Temp. &amp; Humidity</b>	26°C, 52%

966 Chamber\_C at 3Meter / Horizontal

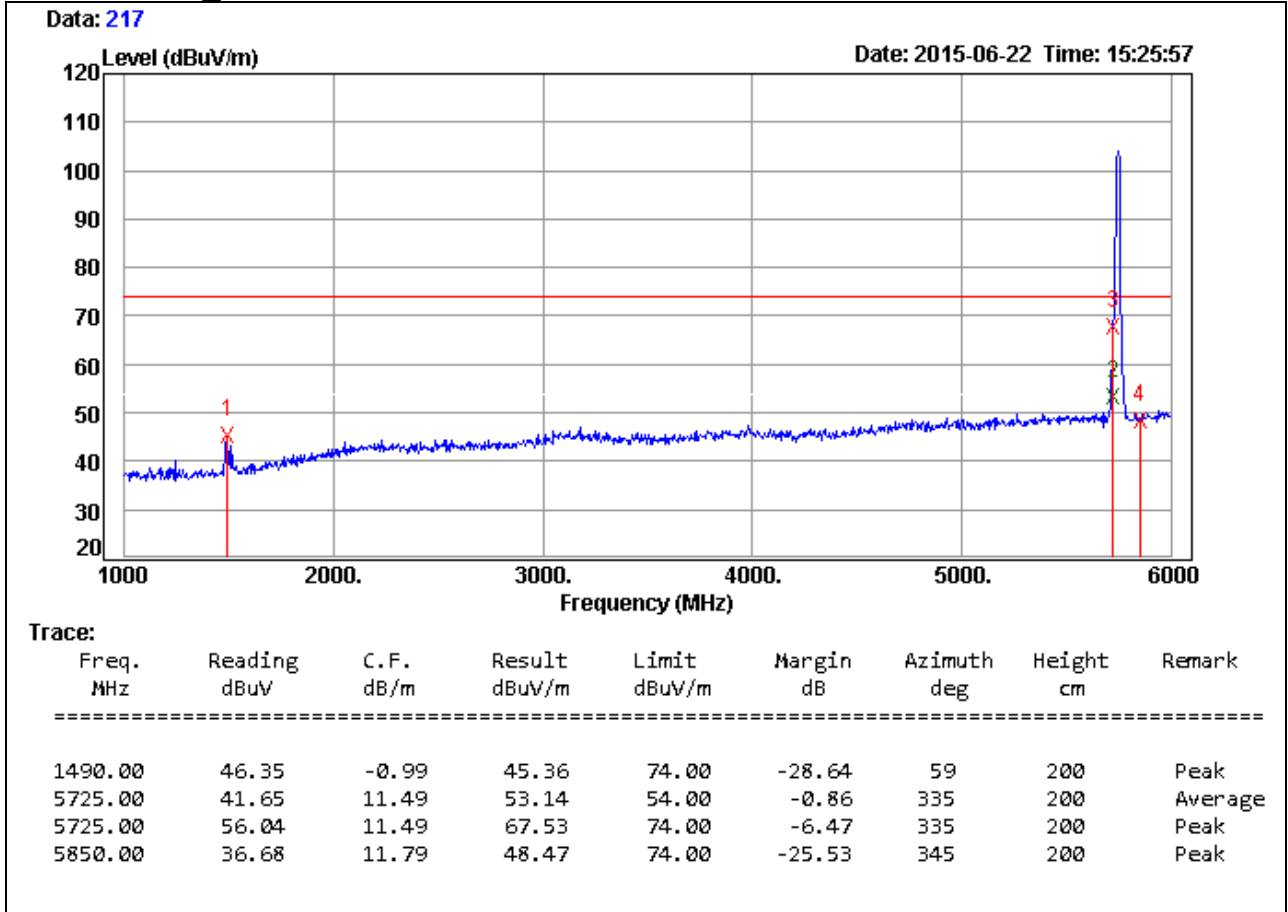

**Remark:**

1. Measuring frequencies from 1 GHz to the 10th harmonic of highest fundamental frequency.
2. Average test would be performed if the peak result were greater than the average limit.
3. Measurements above show only up to 6 maximum emissions noted, or would be lesser, with " N/A " remark, if no specific emissions from the EUT are recorded (ie: margin>20dB from the applicable limit) and considered that's already beyond the background noise floor.
4. Result = Reading + Correction Factor  
 Margin = Result - Limit  
 Remark Peak = Result(PK) - Limit(PK)  
 Remark AVG = Result(AV) - Limit(AV)



<b>Product Name</b>	Computer	<b>Test By</b>	Watniril Guan
<b>Test Model</b>	POC127	<b>Test Date</b>	2015/06/18
<b>Test Mode</b>	UNII Band 3/ IEEE 802.11an HT20 TX / CH Low	<b>Temp. &amp; Humidity</b>	26°C, 52%

966 Chamber\_C at 3Meter / Horizontal

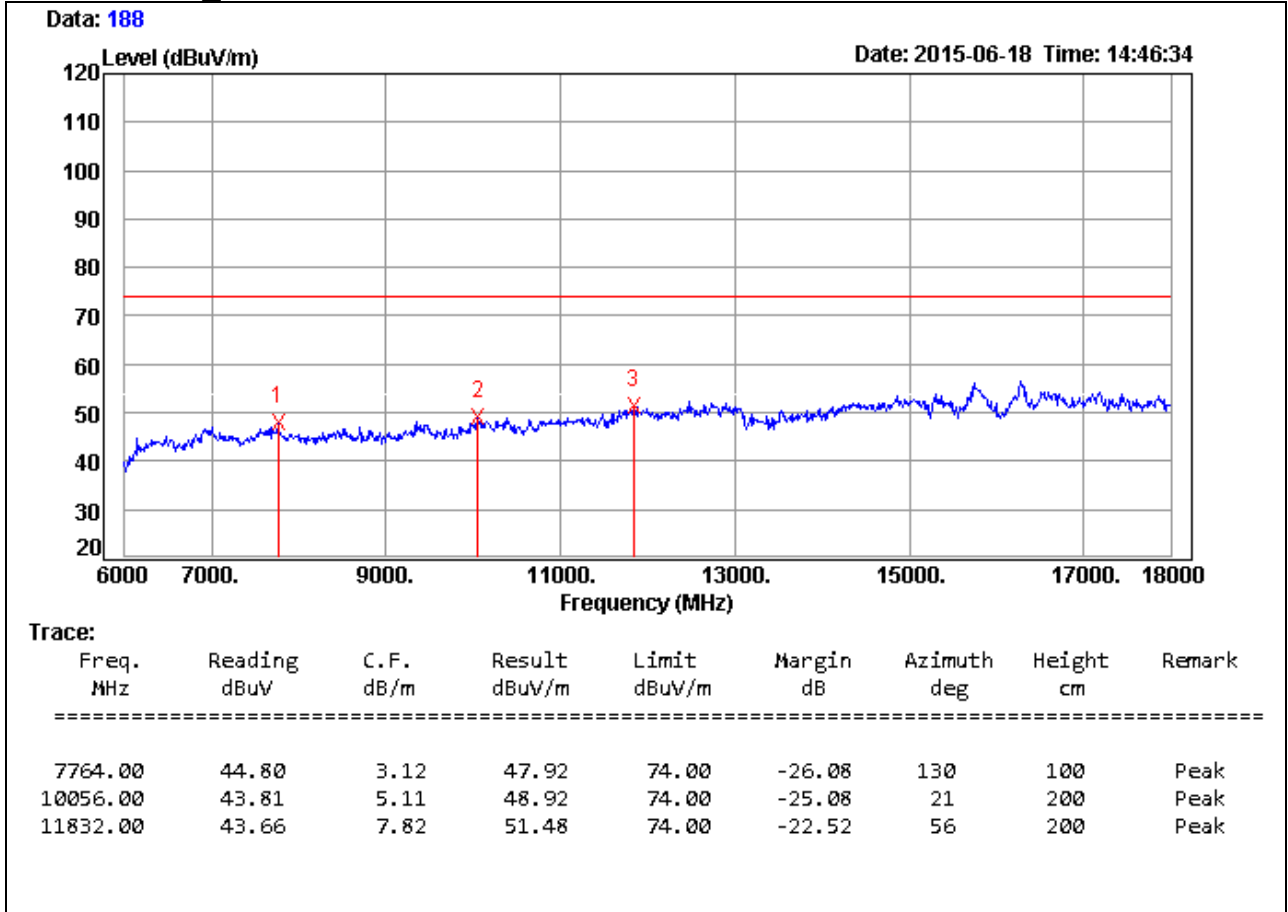

**Remark:**

1. Measuring frequencies from 1 GHz to the 10th harmonic of highest fundamental frequency.
2. Average test would be performed if the peak result were greater than the average limit.
3. Measurements above show only up to 6 maximum emissions noted, or would be lesser, with " N/A " remark, if no specific emissions from the EUT are recorded (ie: margin>20dB from the applicable limit) and considered that's already beyond the background noise floor.
4. Result = Reading + Correction Factor  
Margin = Result - Limit  
Remark Peak = Result(PK) - Limit(PK)  
Remark AVG = Result(AV) - Limit(AV)
5. There is no emission in 18GHz ~ 40GHz.

<b>Product Name</b>	Computer	<b>Test By</b>	Waternil Guan
<b>Test Model</b>	POC127	<b>Test Date</b>	2015/06/22
<b>Test Mode</b>	UNII Band 3/ IEEE 802.11an HT20 TX / CH Low	<b>Temp. &amp; Humidity</b>	26°C, 52%

966 Chamber\_C at 3Meter / Vertical

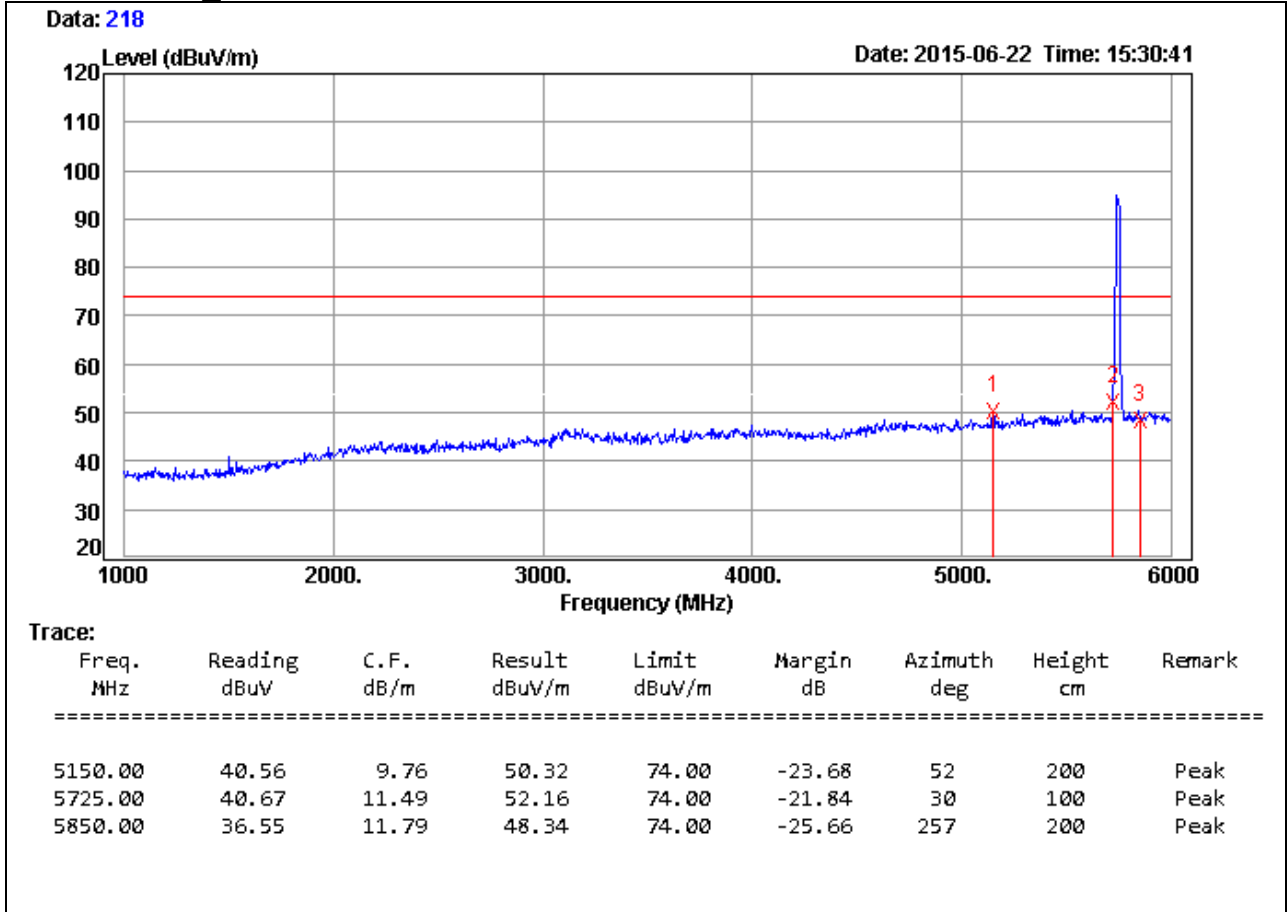

**Remark:**

1. Measuring frequencies from 1 GHz to the 10th harmonic of highest fundamental frequency.
2. Average test would be performed if the peak result were greater than the average limit.
3. Measurements above show only up to 6 maximum emissions noted, or would be lesser, with " N/A " remark, if no specific emissions from the EUT are recorded (ie: margin>20dB from the applicable limit) and considered that's already beyond the background noise floor.
4.  $Result = Reading + Correction\ Factor$   
 $Margin = Result - Limit$   
 $Remark\ Peak = Result(PK) - Limit(PK)$   
 $Remark\ AVG = Result(AV) - Limit(AV)$

<b>Product Name</b>	Computer	<b>Test By</b>	Waternil Guan
<b>Test Model</b>	POC127	<b>Test Date</b>	2015/06/18
<b>Test Mode</b>	UNII Band 3/ IEEE 802.11an HT20 TX / CH Low	<b>Temp. &amp; Humidity</b>	26°C, 52%

966 Chamber\_C at 3Meter / Vertical

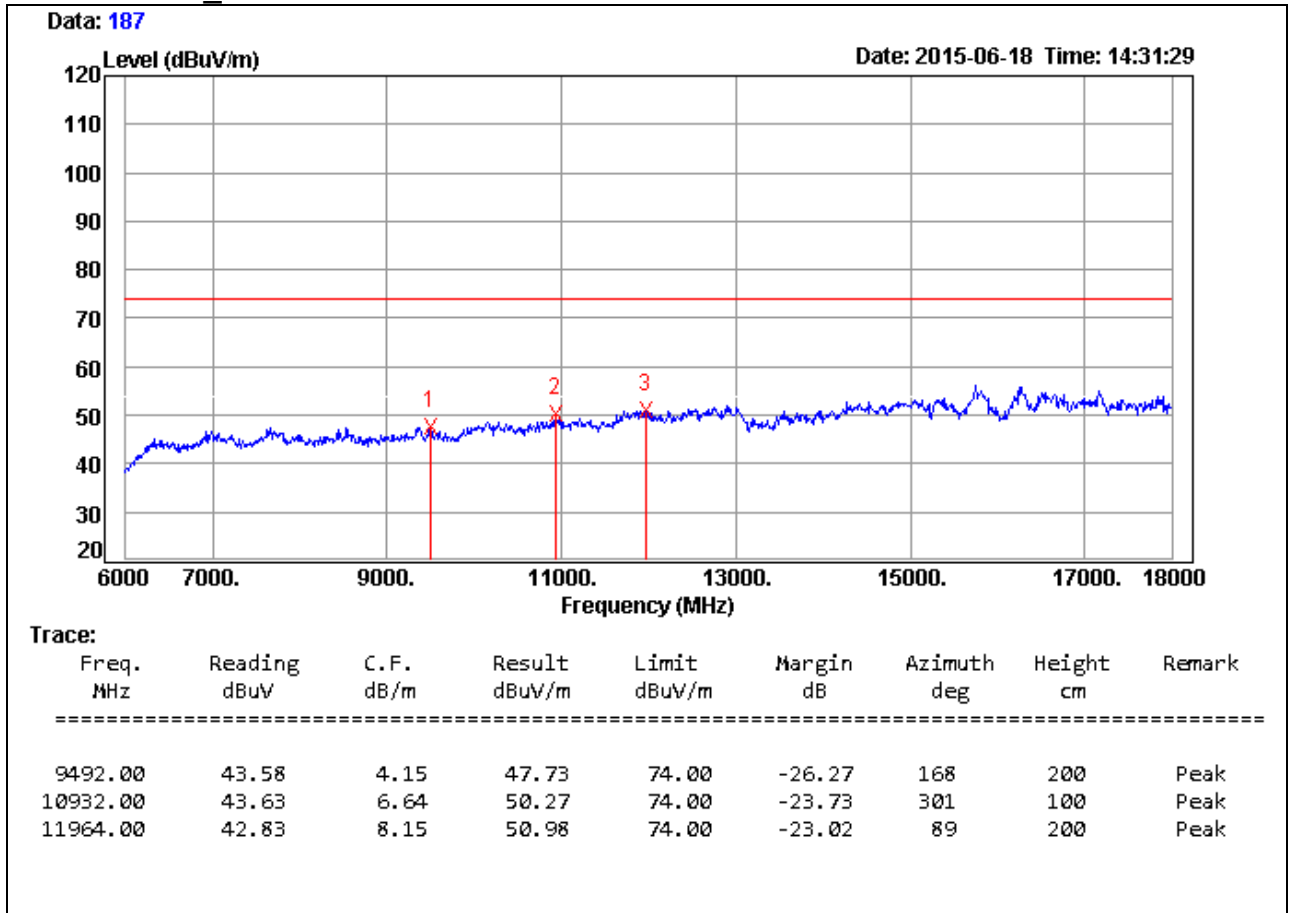

**Remark:**

1. Measuring frequencies from 1 GHz to the 10th harmonic of highest fundamental frequency.
2. Average test would be performed if the peak result were greater than the average limit.
3. Measurements above show only up to 6 maximum emissions noted, or would be lesser, with " N/A " remark, if no specific emissions from the EUT are recorded (ie: margin>20dB from the applicable limit) and considered that's already beyond the background noise floor.
4. Result = Reading + Correction Factor  
Margin = Result – Limit  
Remark Peak = Result(PK) – Limit(PK)  
Remark AVG = Result(AV) – Limit(AV)
5. There is no emission in 18GHz ~ 40GHz.

<b>Product Name</b>	Computer	<b>Test By</b>	Watniril Guan
<b>Test Model</b>	POC127	<b>Test Date</b>	2015/06/22
<b>Test Mode</b>	UNII Band 3/ IEEE 802.11an HT20 TX / CH Middle	<b>Temp. &amp; Humidity</b>	26°C, 52%

966 Chamber\_C at 3Meter / Horizontal

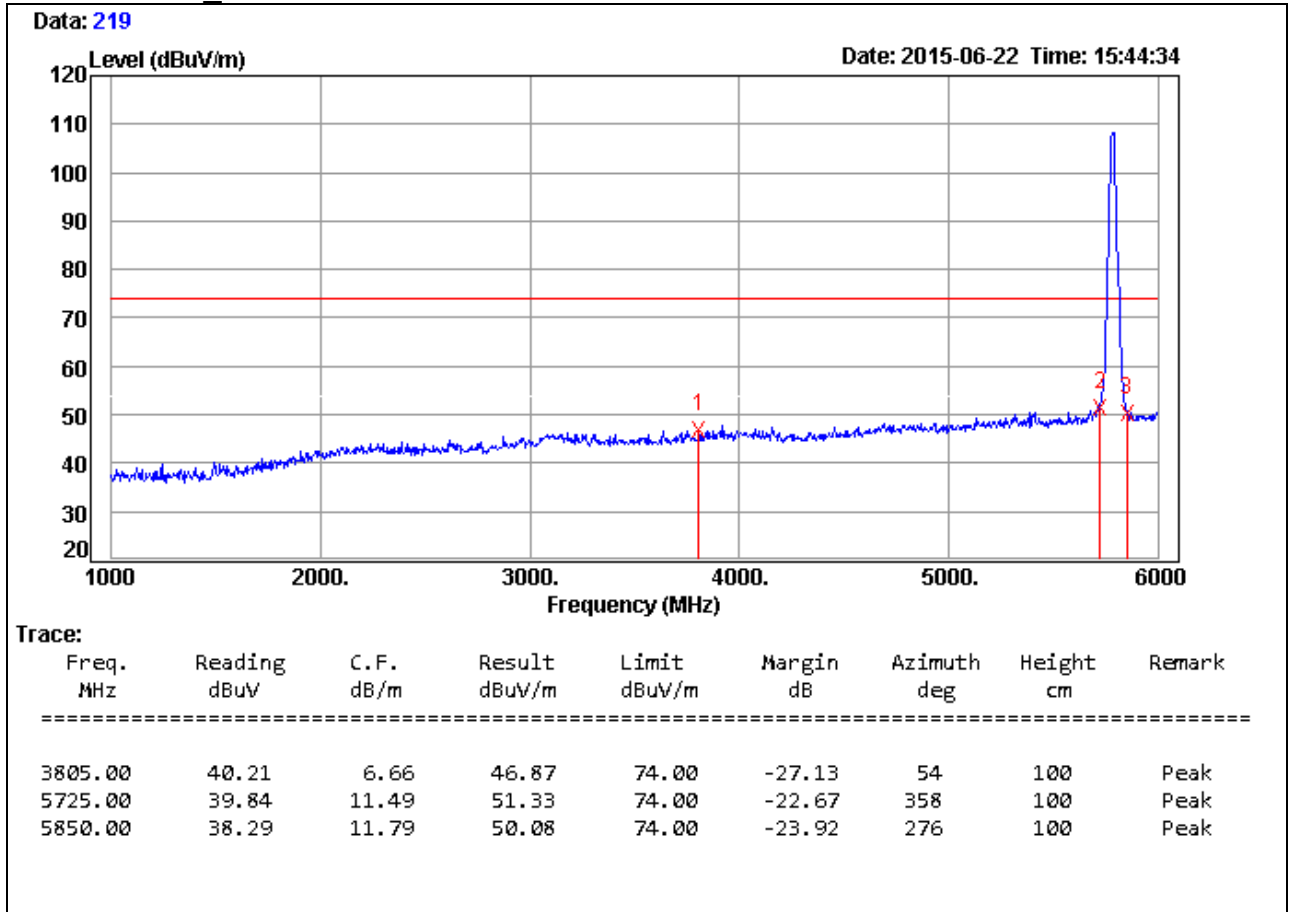

**Remark:**

1. Measuring frequencies from 1 GHz to the 10th harmonic of highest fundamental frequency.
2. Average test would be performed if the peak result were greater than the average limit.
3. Measurements above show only up to 6 maximum emissions noted, or would be lesser, with " N/A " remark, if no specific emissions from the EUT are recorded (ie: margin>20dB from the applicable limit) and considered that's already beyond the background noise floor.
4. Result = Reading + Correction Factor  
Margin = Result - Limit  
Remark Peak = Result(PK) - Limit(PK)  
Remark AVG = Result(AV) - Limit(AV)

<b>Product Name</b>	Computer	<b>Test By</b>	Watniril Guan
<b>Test Model</b>	POC127	<b>Test Date</b>	2015/06/18
<b>Test Mode</b>	UNII Band 3/ IEEE 802.11an HT20 TX / CH Middle	<b>Temp. &amp; Humidity</b>	26°C, 52%

966 Chamber\_C at 3Meter / Horizontal

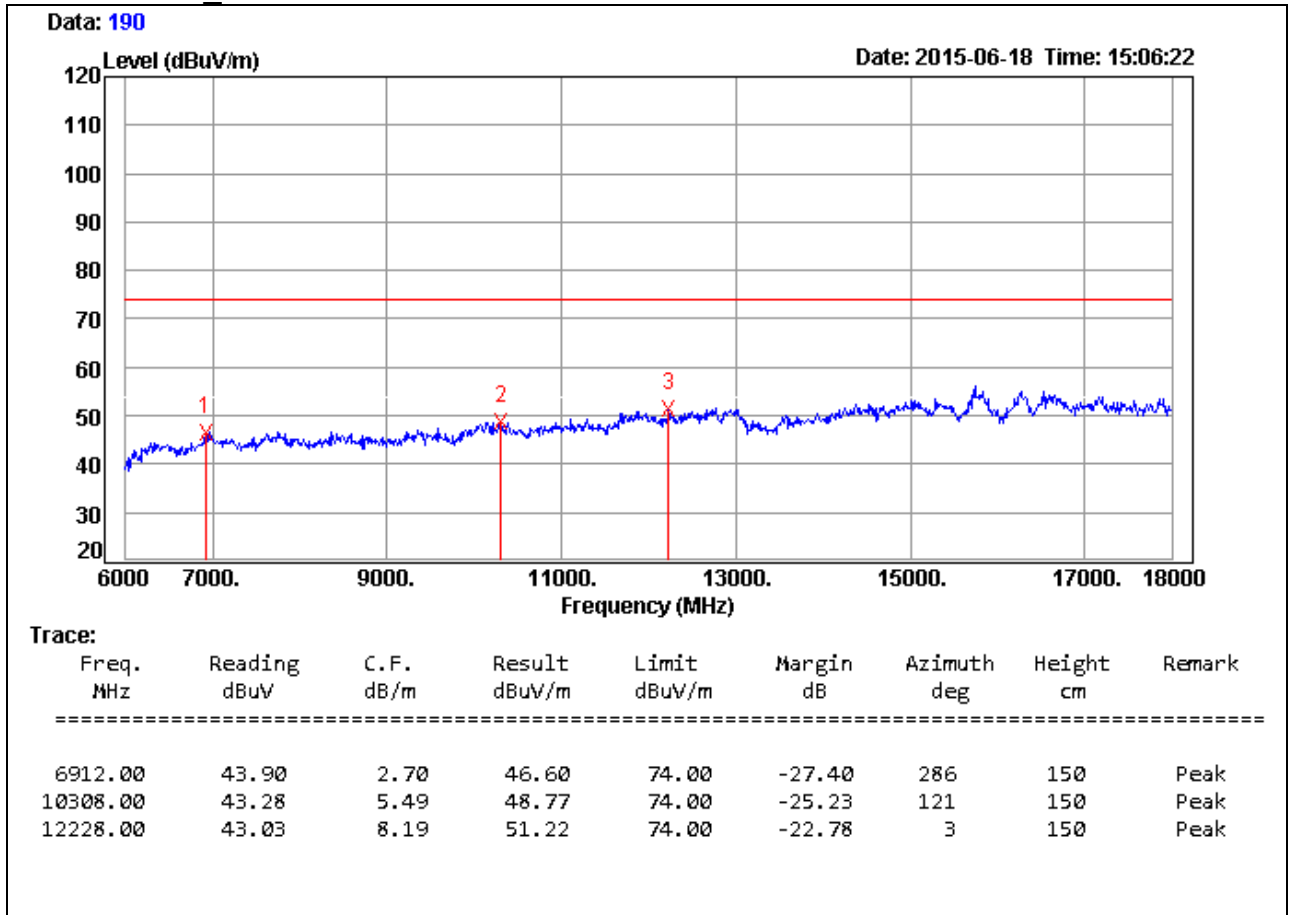

**Remark:**

1. Measuring frequencies from 1 GHz to the 10th harmonic of highest fundamental frequency.
2. Average test would be performed if the peak result were greater than the average limit.
3. Measurements above show only up to 6 maximum emissions noted, or would be lesser, with " N/A " remark, if no specific emissions from the EUT are recorded (ie: margin>20dB from the applicable limit) and considered that's already beyond the background noise floor.
4. Result = Reading + Correction Factor  
Margin = Result - Limit  
Remark Peak = Result(PK) - Limit(PK)  
Remark AVG = Result(AV) - Limit(AV)
5. There is no emission in 18GHz ~ 40GHz.

<b>Product Name</b>	Computer	<b>Test By</b>	Waternil Guan
<b>Test Model</b>	POC127	<b>Test Date</b>	2015/06/22
<b>Test Mode</b>	UNII Band 3/ IEEE 802.11an HT20 TX / CH Middle	<b>Temp. &amp; Humidity</b>	26°C, 52%

966 Chamber\_C at 3Meter / Vertical

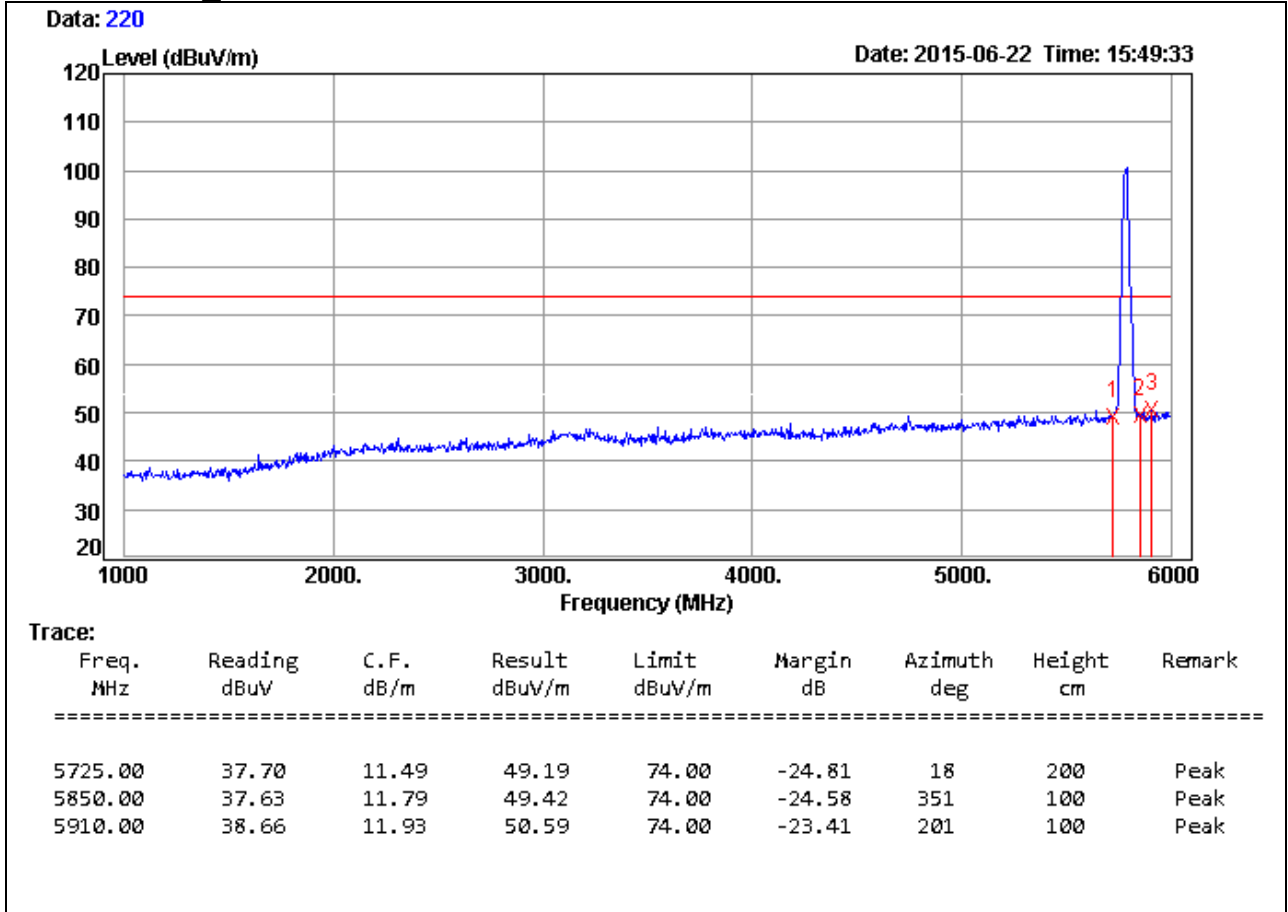

**Remark:**

1. Measuring frequencies from 1 GHz to the 10th harmonic of highest fundamental frequency.
2. Average test would be performed if the peak result were greater than the average limit.
3. Measurements above show only up to 6 maximum emissions noted, or would be lesser, with " N/A " remark, if no specific emissions from the EUT are recorded (ie: margin>20dB from the applicable limit) and considered that's already beyond the background noise floor.
4.  $Result = Reading + Correction\ Factor$   
 $Margin = Result - Limit$   
 $Remark\ Peak = Result(PK) - Limit(PK)$   
 $Remark\ AVG = Result(AV) - Limit(AV)$

<b>Product Name</b>	Computer	<b>Test By</b>	Waternil Guan
<b>Test Model</b>	POC127	<b>Test Date</b>	2015/06/18
<b>Test Mode</b>	UNII Band 3/ IEEE 802.11an HT20 TX / CH Middle	<b>Temp. &amp; Humidity</b>	26°C, 52%

966 Chamber\_C at 3Meter / Vertical

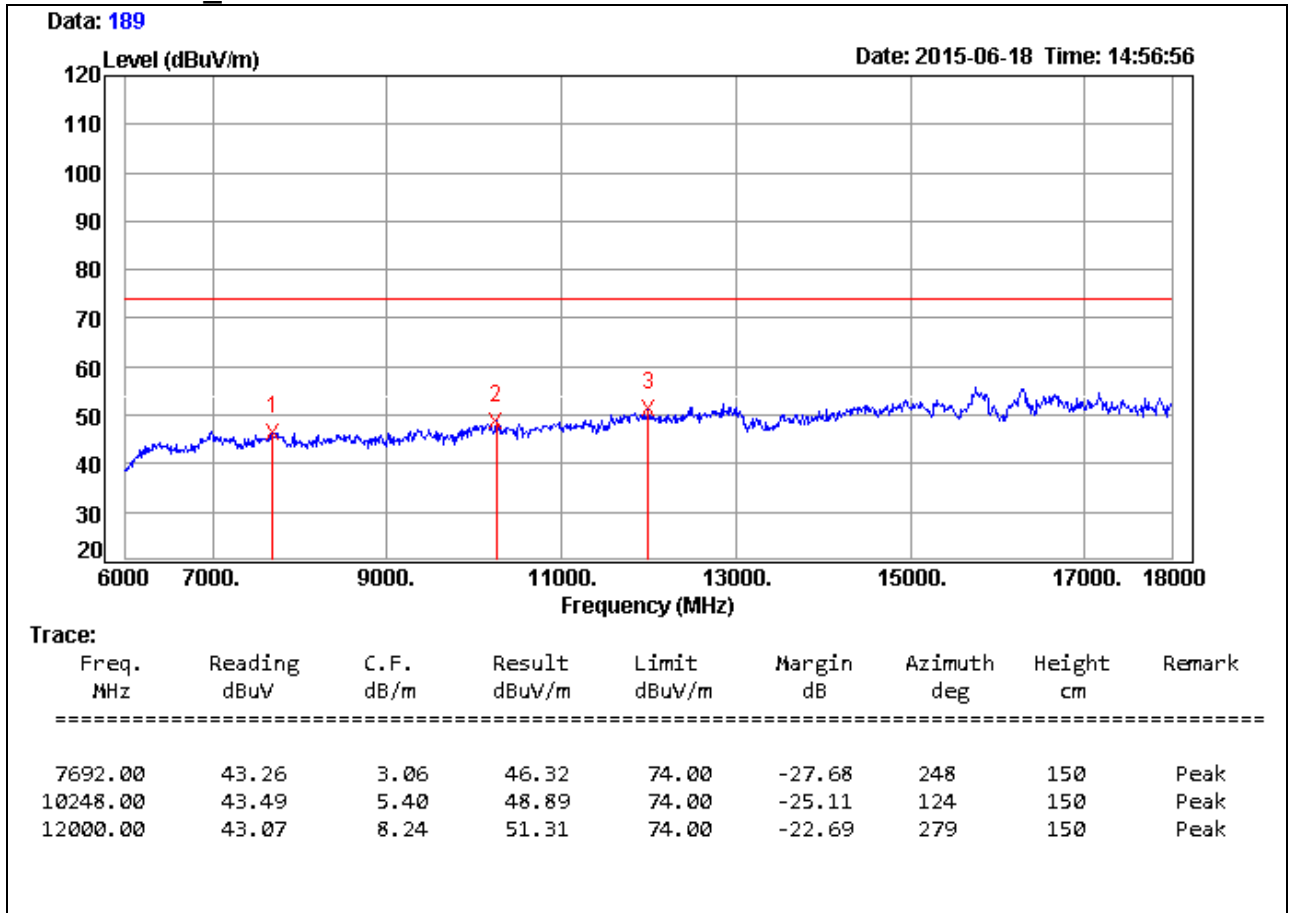

**Remark:**

1. Measuring frequencies from 1 GHz to the 10th harmonic of highest fundamental frequency.
2. Average test would be performed if the peak result were greater than the average limit.
3. Measurements above show only up to 6 maximum emissions noted, or would be lesser, with " N/A " remark, if no specific emissions from the EUT are recorded (ie: margin>20dB from the applicable limit) and considered that's already beyond the background noise floor.
4. Result = Reading + Correction Factor  
Margin = Result - Limit  
Remark Peak = Result(PK) - Limit(PK)  
Remark AVG = Result(AV) - Limit(AV)
5. There is no emission in 18GHz ~ 40GHz.

<b>Product Name</b>	Computer	<b>Test By</b>	Waternil Guan
<b>Test Model</b>	POC127	<b>Test Date</b>	2015/06/22
<b>Test Mode</b>	UNII Band 3/ IEEE 802.11an HT20 TX / CH High	<b>Temp. &amp; Humidity</b>	26°C, 52%

966 Chamber\_C at 3Meter / Horizontal

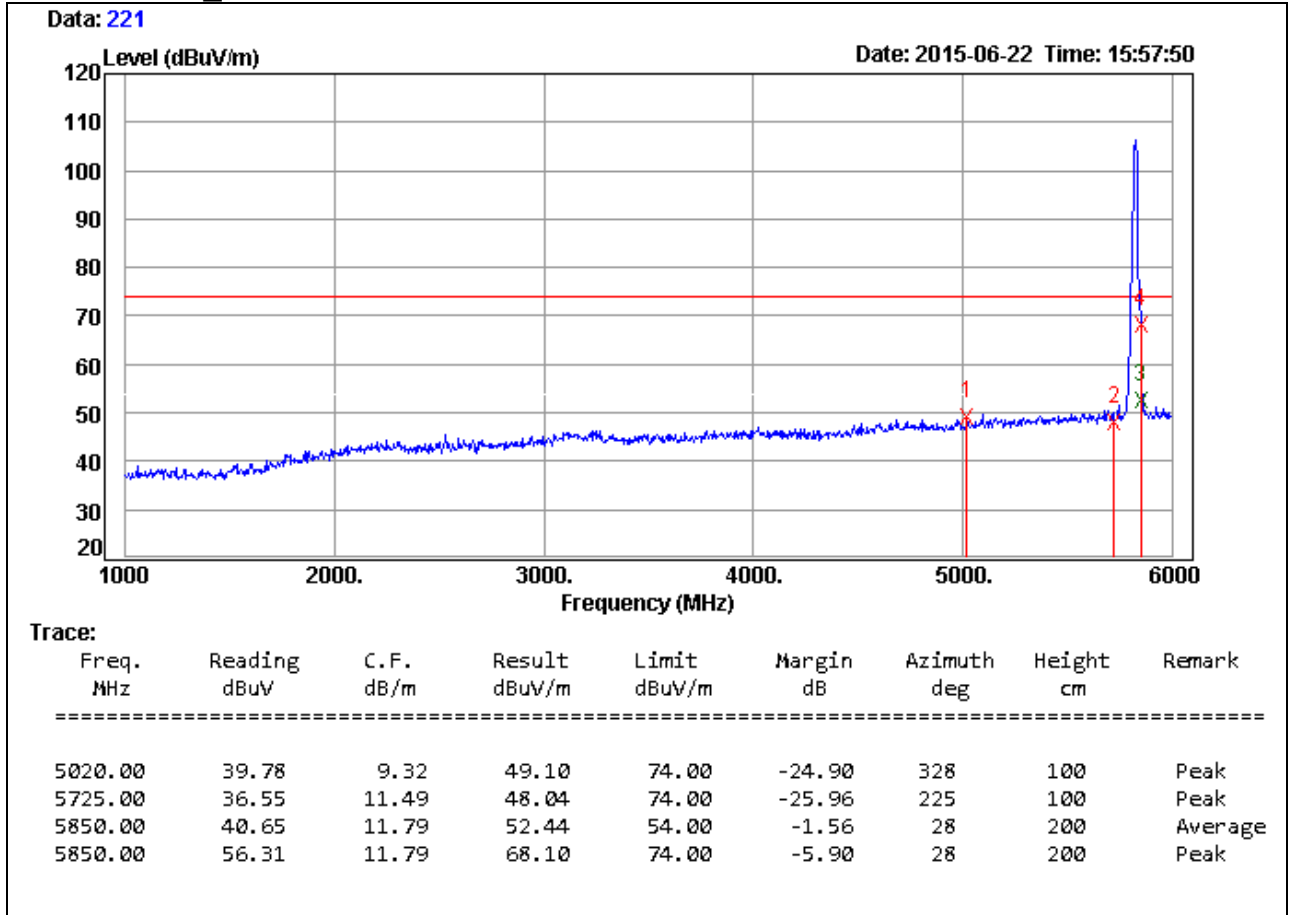

**Remark:**

1. Measuring frequencies from 1 GHz to the 10th harmonic of highest fundamental frequency.
2. Average test would be performed if the peak result were greater than the average limit.
3. Measurements above show only up to 6 maximum emissions noted, or would be lesser, with " N/A " remark, if no specific emissions from the EUT are recorded (ie: margin>20dB from the applicable limit) and considered that's already beyond the background noise floor.
4.  $Result = Reading + Correction\ Factor$   
 $Margin = Result - Limit$   
 $Remark\ Peak = Result(PK) - Limit(PK)$   
 $Remark\ AVG = Result(AV) - Limit(AV)$



<b>Product Name</b>	Computer	<b>Test By</b>	Waternil Guan
<b>Test Model</b>	POC127	<b>Test Date</b>	2015/06/18
<b>Test Mode</b>	UNII Band 3/ IEEE 802.11an HT20 TX / CH High	<b>Temp. &amp; Humidity</b>	26°C, 52%

966 Chamber\_C at 3Meter / Horizontal

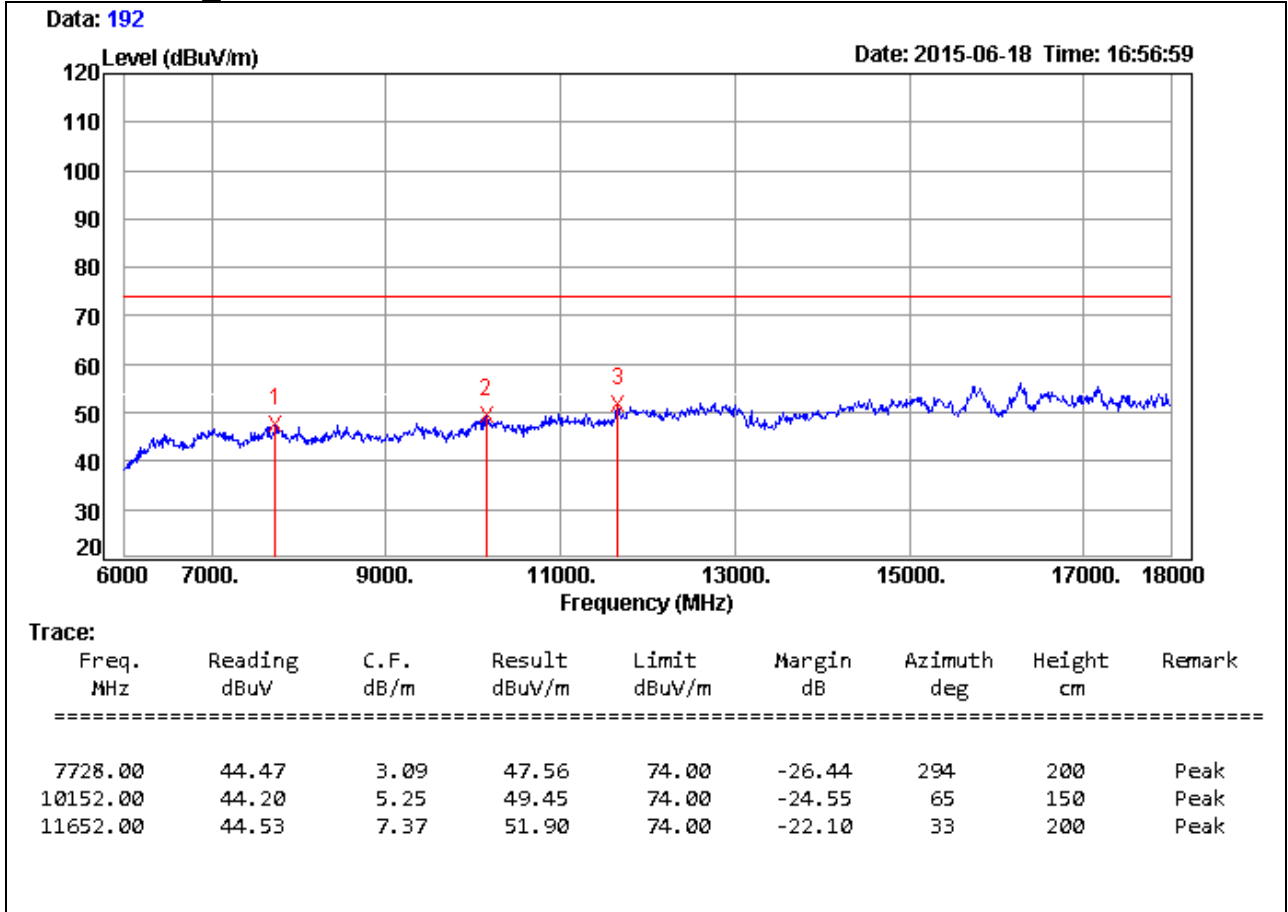

**Remark:**

1. Measuring frequencies from 1 GHz to the 10th harmonic of highest fundamental frequency.
2. Average test would be performed if the peak result were greater than the average limit.
3. Measurements above show only up to 6 maximum emissions noted, or would be lesser, with " N/A " remark, if no specific emissions from the EUT are recorded (ie: margin>20dB from the applicable limit) and considered that's already beyond the background noise floor.
4.  $Result = Reading + Correction\ Factor$   
 $Margin = Result - Limit$   
 $Remark\ Peak = Result(PK) - Limit(PK)$   
 $Remark\ AVG = Result(AV) - Limit(AV)$
5. There is no emission in 18GHz ~ 40GHz.

<b>Product Name</b>	Computer	<b>Test By</b>	Waternil Guan
<b>Test Model</b>	POC127	<b>Test Date</b>	2015/06/22
<b>Test Mode</b>	UNII Band 3/ IEEE 802.11an HT20 TX / CH High	<b>Temp. &amp; Humidity</b>	26°C, 52%

966 Chamber\_C at 3Meter / Vertical

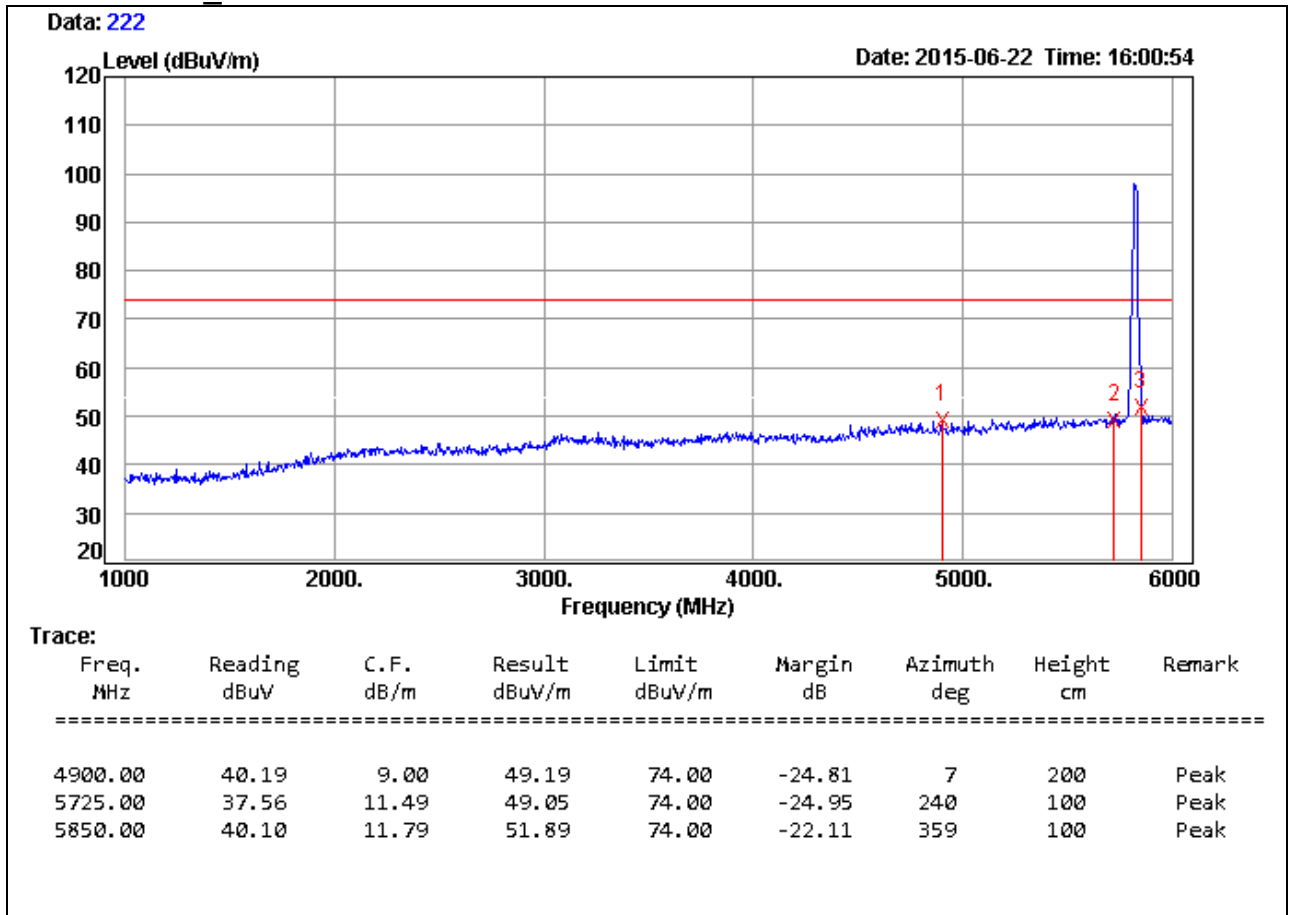

**Remark:**

1. Measuring frequencies from 1 GHz to the 10th harmonic of highest fundamental frequency.
2. Average test would be performed if the peak result were greater than the average limit.
3. Measurements above show only up to 6 maximum emissions noted, or would be lesser, with " N/A " remark, if no specific emissions from the EUT are recorded (ie: margin>20dB from the applicable limit) and considered that's already beyond the background noise floor.
4. Result = Reading + Correction Factor  
 Margin = Result - Limit  
 Remark Peak = Result(PK) - Limit(PK)  
 Remark AVG = Result(AV) - Limit(AV)

<b>Product Name</b>	Computer	<b>Test By</b>	Waternil Guan
<b>Test Model</b>	POC127	<b>Test Date</b>	2015/06/18
<b>Test Mode</b>	UNII Band 3/ IEEE 802.11an HT20 TX / CH High	<b>Temp. &amp; Humidity</b>	26°C, 52%

966 Chamber\_C at 3Meter / Vertical

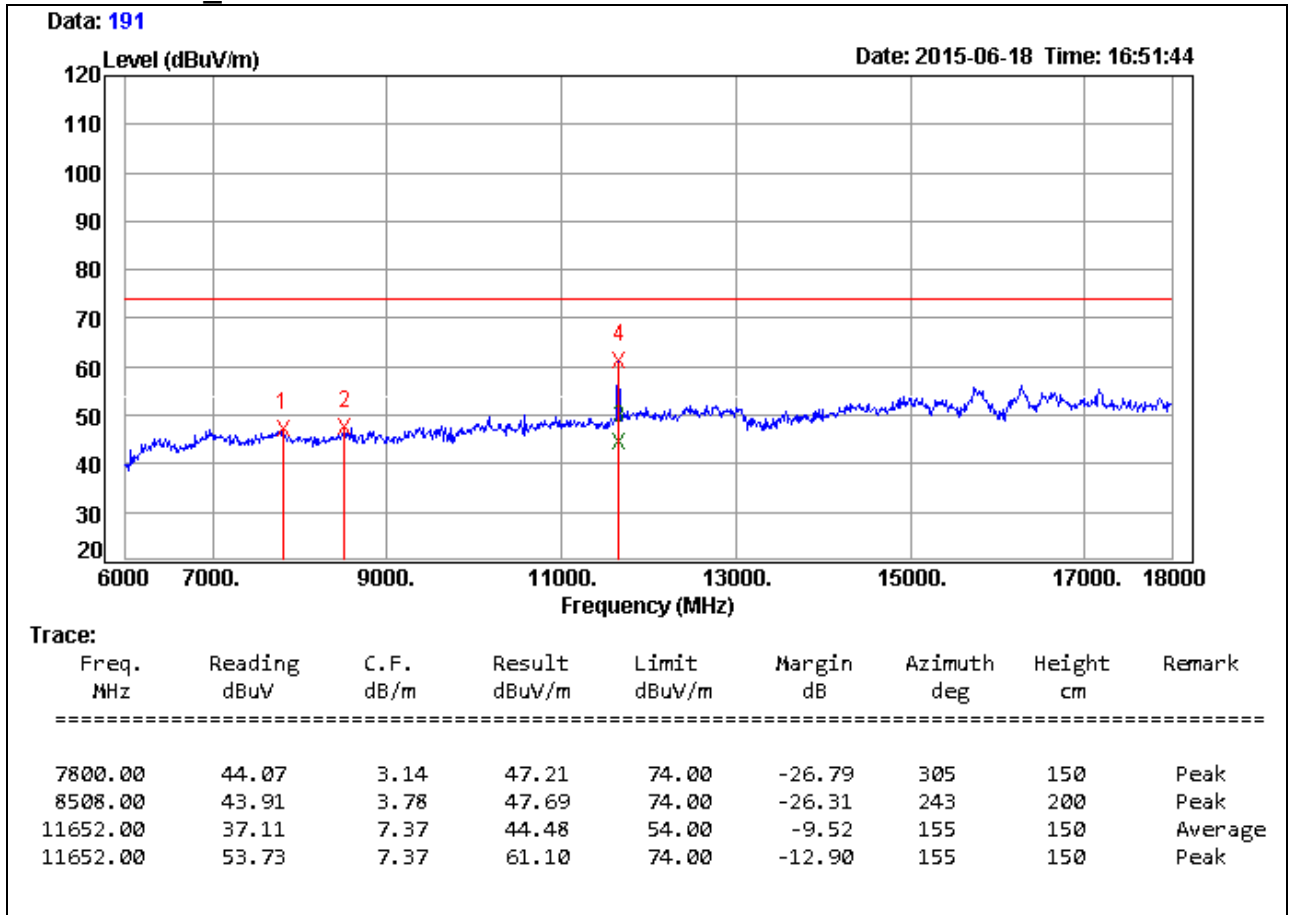

**Remark:**

1. Measuring frequencies from 1 GHz to the 10th harmonic of highest fundamental frequency.
2. Average test would be performed if the peak result were greater than the average limit.
3. Measurements above show only up to 6 maximum emissions noted, or would be lesser, with " N/A " remark, if no specific emissions from the EUT are recorded (ie: margin>20dB from the applicable limit) and considered that's already beyond the background noise floor.
4. Result = Reading + Correction Factor  
 Margin = Result - Limit  
 Remark Peak = Result(PK) - Limit(PK)  
 Remark AVG = Result(AV) - Limit(AV)
5. There is no emission in 18GHz ~ 40GHz.

<b>Product Name</b>	Computer	<b>Test By</b>	Waternil Guan
<b>Test Model</b>	POC127	<b>Test Date</b>	2015/06/22
<b>Test Mode</b>	UNII Band 3/ IEEE 802.11an HT40 TX / CH Low	<b>Temp. &amp; Humidity</b>	26°C, 52%

966 Chamber\_C at 3Meter / Horizontal

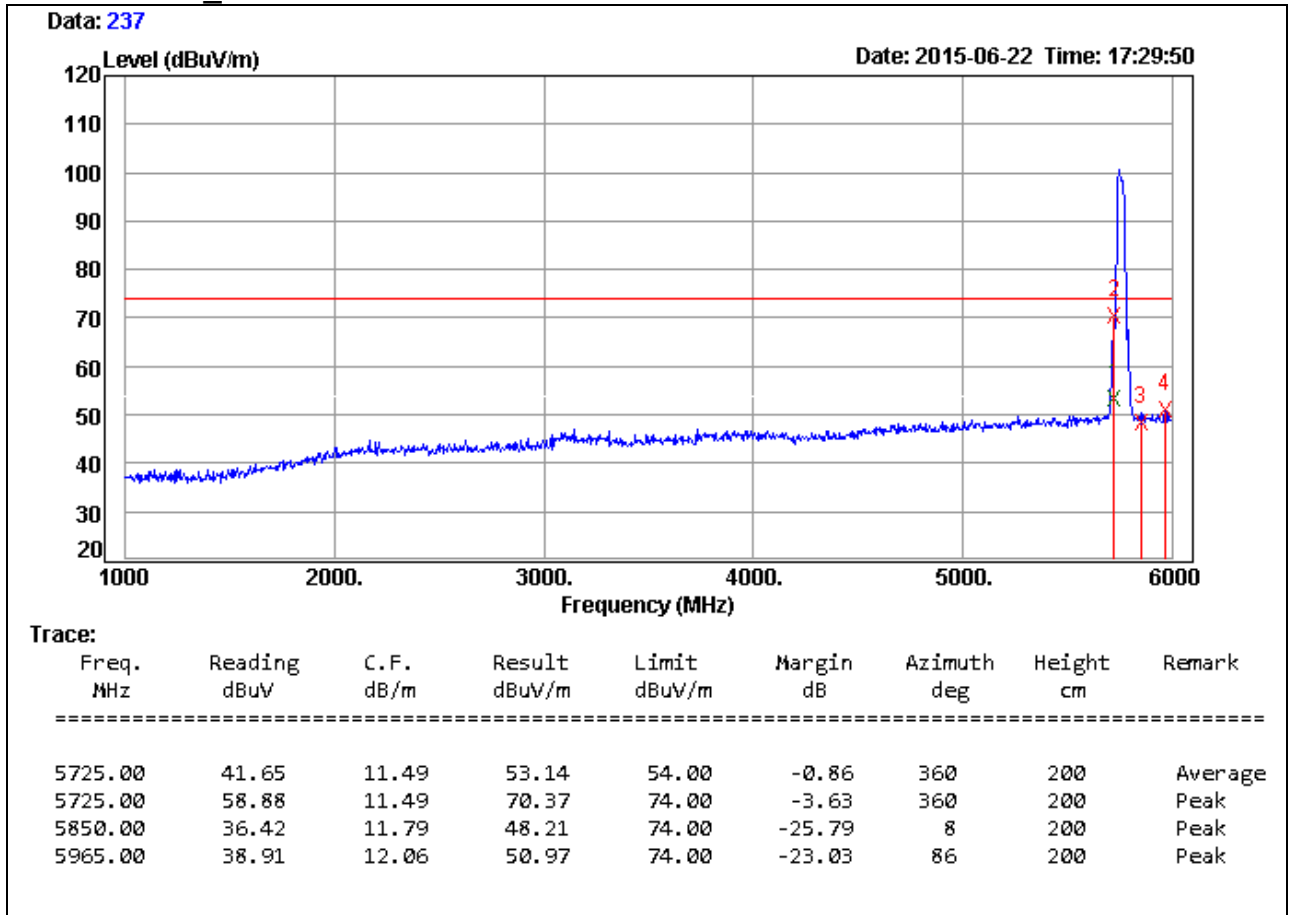

**Remark:**

1. Measuring frequencies from 1 GHz to the 10th harmonic of highest fundamental frequency.
2. Average test would be performed if the peak result were greater than the average limit.
3. Measurements above show only up to 6 maximum emissions noted, or would be lesser, with " N/A " remark, if no specific emissions from the EUT are recorded (ie: margin>20dB from the applicable limit) and considered that's already beyond the background noise floor.
4. Result = Reading + Correction Factor  
Margin = Result - Limit  
Remark Peak = Result(PK) - Limit(PK)  
Remark AVG = Result(AV) - Limit(AV)

<b>Product Name</b>	Computer	<b>Test By</b>	Waternil Guan
<b>Test Model</b>	POC127	<b>Test Date</b>	2015/06/18
<b>Test Mode</b>	UNII Band 3/ IEEE 802.11an HT40 TX / CH Low	<b>Temp. &amp; Humidity</b>	26°C, 52%

966 Chamber\_C at 3Meter / Horizontal

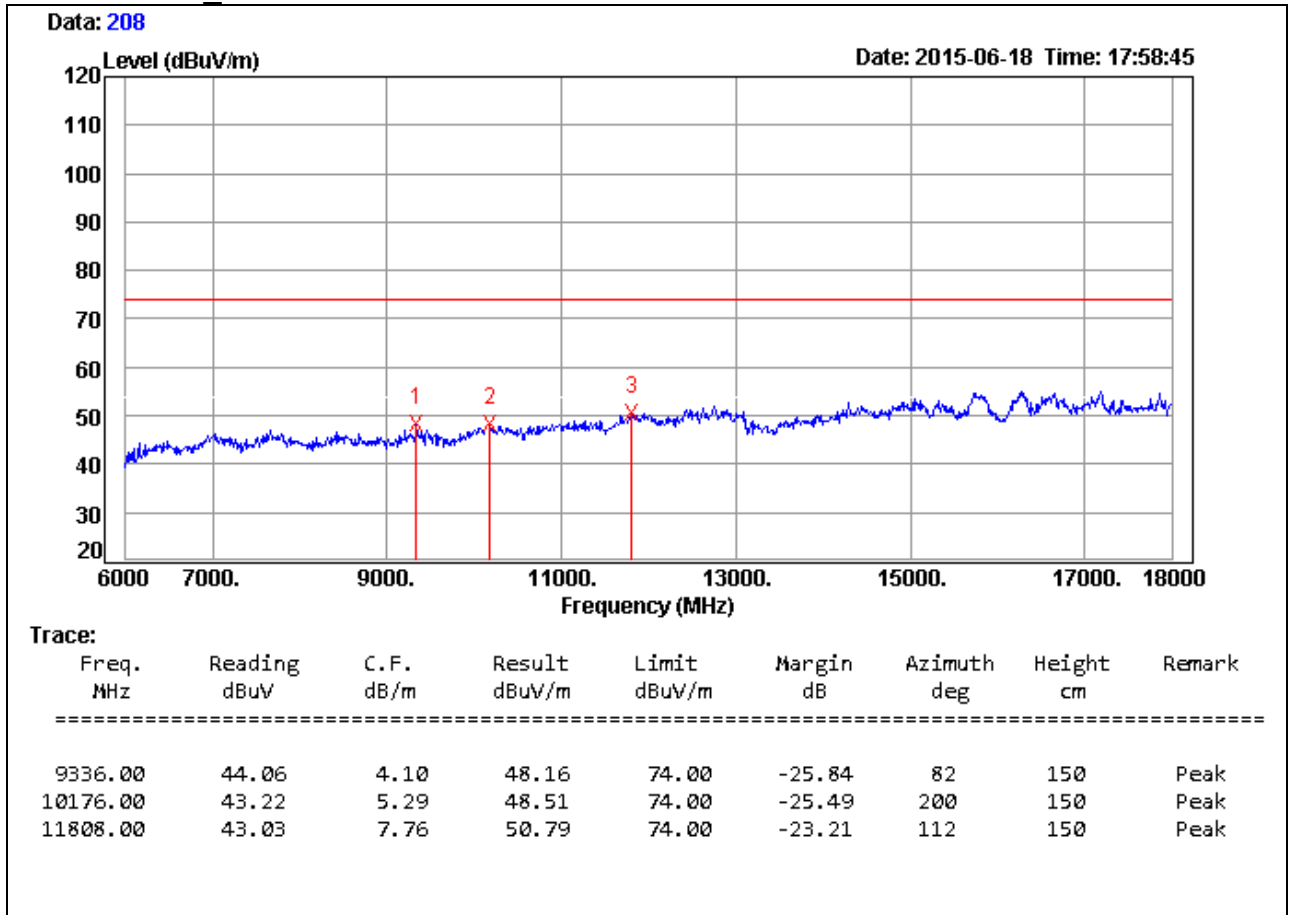

**Remark:**

1. Measuring frequencies from 1 GHz to the 10th harmonic of highest fundamental frequency.
2. Average test would be performed if the peak result were greater than the average limit.
3. Measurements above show only up to 6 maximum emissions noted, or would be lesser, with " N/A " remark, if no specific emissions from the EUT are recorded (ie: margin>20dB from the applicable limit) and considered that's already beyond the background noise floor.
4. Result = Reading + Correction Factor  
Margin = Result - Limit  
Remark Peak = Result(PK) - Limit(PK)  
Remark AVG = Result(AV) - Limit(AV)
5. There is no emission in 18GHz ~ 40GHz.

<b>Product Name</b>	Computer	<b>Test By</b>	Waternil Guan
<b>Test Model</b>	POC127	<b>Test Date</b>	2014/06/22
<b>Test Mode</b>	UNII Band 3/ IEEE 802.11an HT40 TX / CH Low	<b>Temp. &amp; Humidity</b>	26°C, 52%

966 Chamber\_C at 3Meter / Vertical

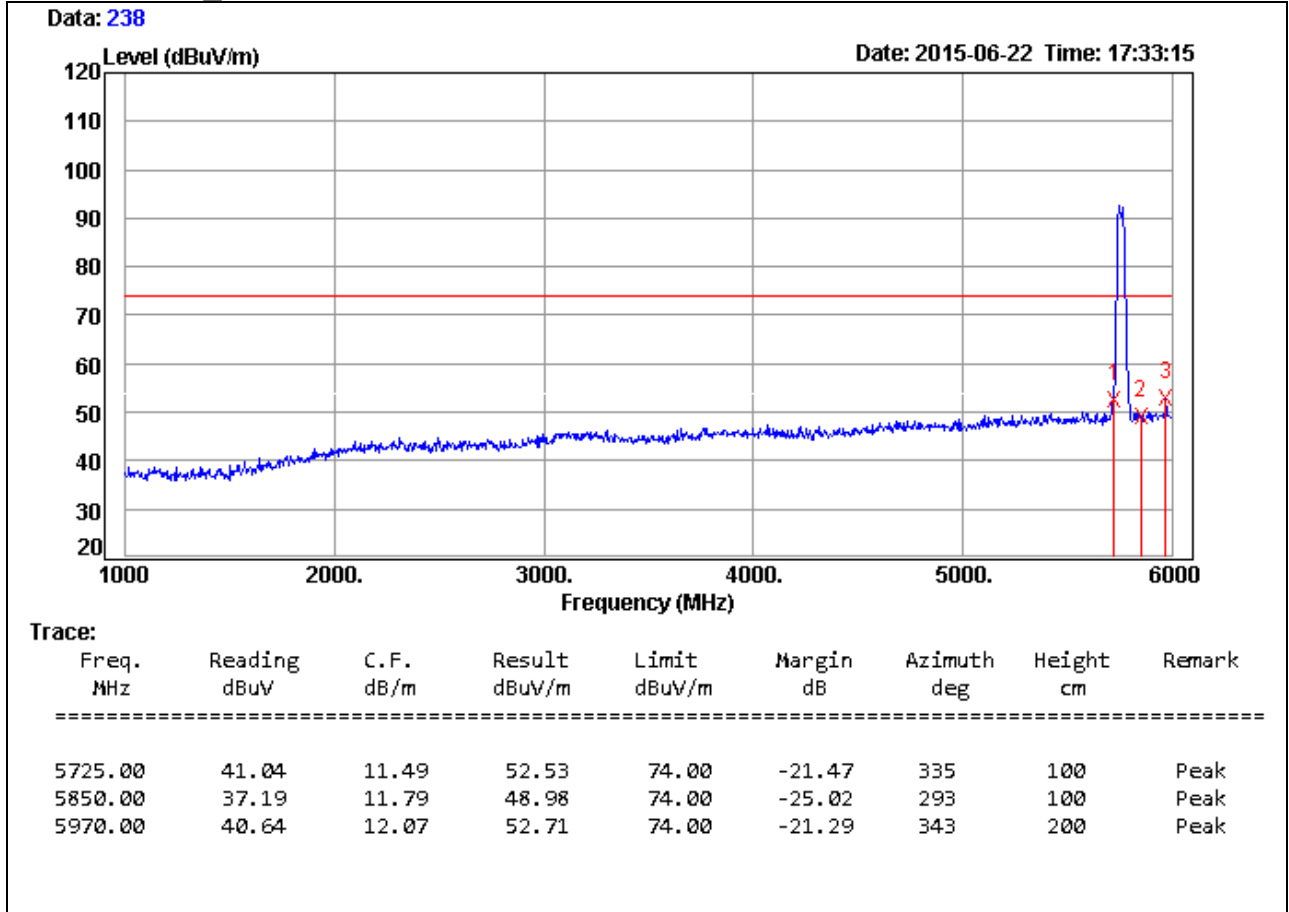

**Remark:**

1. Measuring frequencies from 1 GHz to the 10th harmonic of highest fundamental frequency.
2. Average test would be performed if the peak result were greater than the average limit.
3. Measurements above show only up to 6 maximum emissions noted, or would be lesser, with " N/A " remark, if no specific emissions from the EUT are recorded (ie: margin>20dB from the applicable limit) and considered that's already beyond the background noise floor.
4. Result = Reading + Correction Factor  
 Margin = Result - Limit  
 Remark Peak = Result(PK) - Limit(PK)  
 Remark AVG = Result(AV) - Limit(AV)

<b>Product Name</b>	Computer	<b>Test By</b>	Waternil Guan
<b>Test Model</b>	POC127	<b>Test Date</b>	2015/06/18
<b>Test Mode</b>	UNII Band 3/ IEEE 802.11an HT40 TX / CH Low	<b>Temp. &amp; Humidity</b>	26°C, 52%

966 Chamber\_C at 3Meter / Vertical

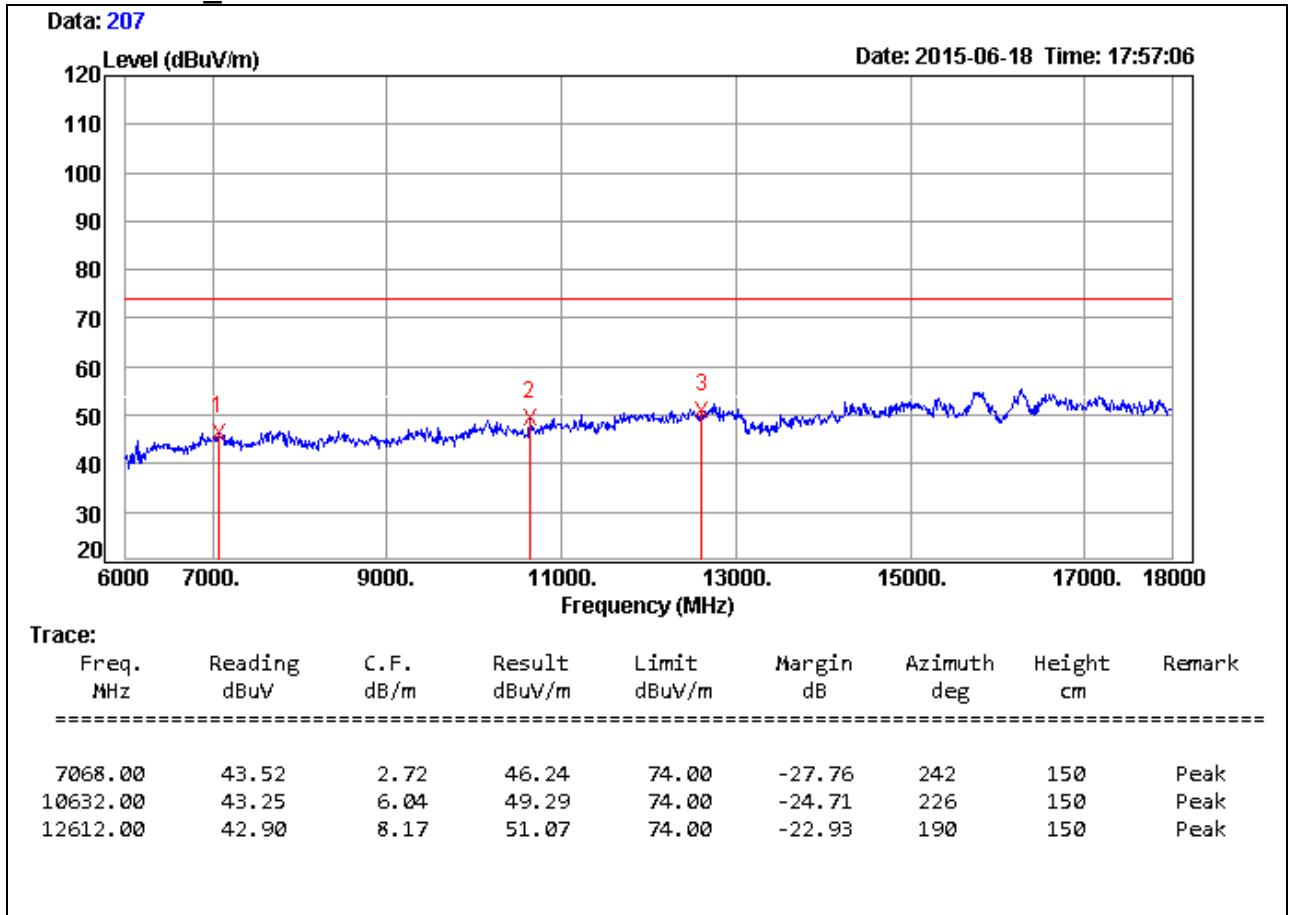

**Remark:**

1. Measuring frequencies from 1 GHz to the 10th harmonic of highest fundamental frequency.
2. Average test would be performed if the peak result were greater than the average limit.
3. Measurements above show only up to 6 maximum emissions noted, or would be lesser, with " N/A " remark, if no specific emissions from the EUT are recorded (ie: margin>20dB from the applicable limit) and considered that's already beyond the background noise floor.
4.  $Result = Reading + Correction\ Factor$   
 $Margin = Result - Limit$   
 $Remark\ Peak = Result(PK) - Limit(PK)$   
 $Remark\ AVG = Result(AV) - Limit(AV)$
5. There is no emission in 18GHz ~ 40GHz.

<b>Product Name</b>	Computer	<b>Test By</b>	Waternil Guan
<b>Test Model</b>	POC127	<b>Test Date</b>	2015/06/22
<b>Test Mode</b>	UNII Band 3/ IEEE 802.11an HT40 TX / CH High	<b>Temp. &amp; Humidity</b>	26°C, 52%

966 Chamber\_C at 3Meter / Horizontal

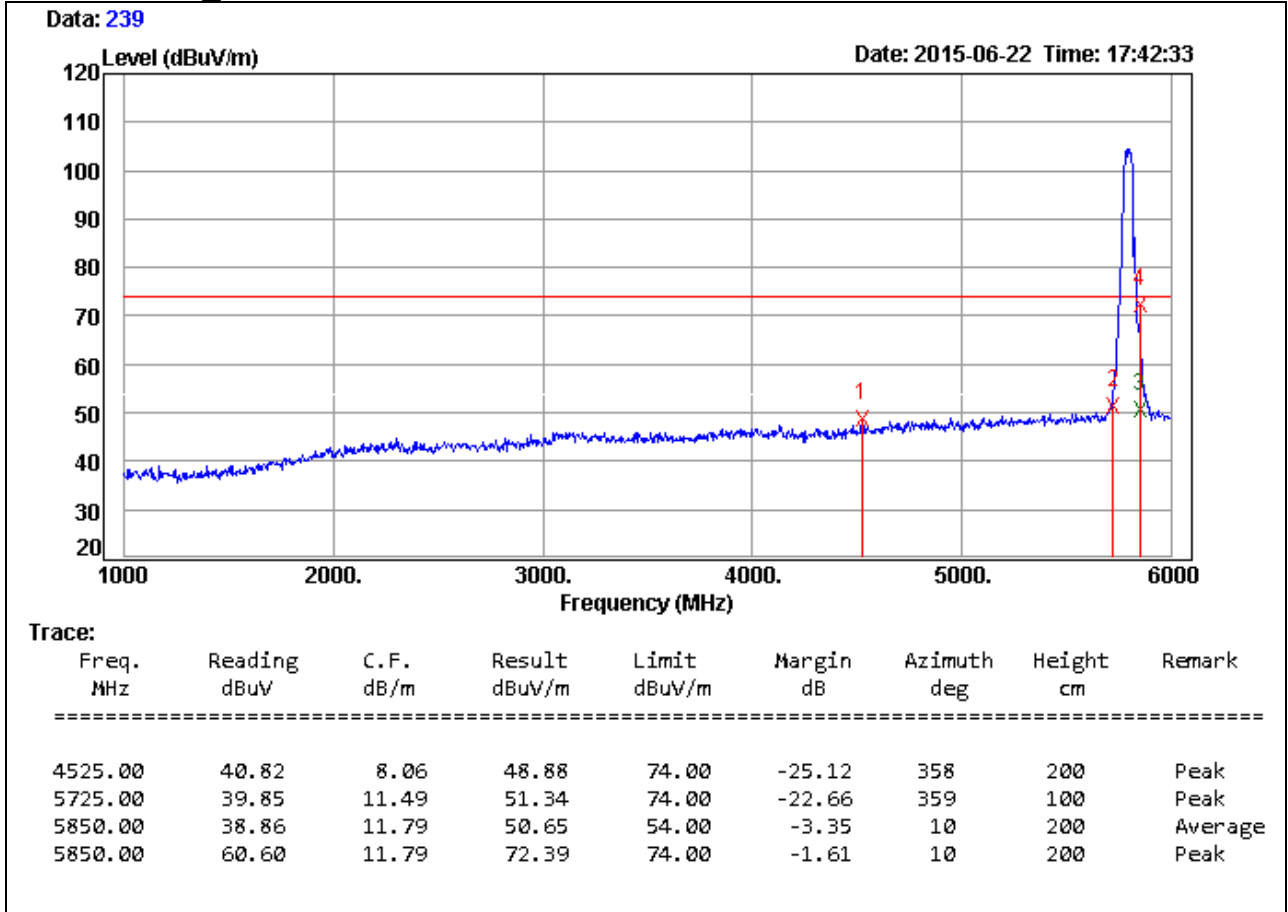

**Remark:**

1. Measuring frequencies from 1 GHz to the 10th harmonic of highest fundamental frequency.
2. Average test would be performed if the peak result were greater than the average limit.
3. Measurements above show only up to 6 maximum emissions noted, or would be lesser, with " N/A " remark, if no specific emissions from the EUT are recorded (ie: margin>20dB from the applicable limit) and considered that's already beyond the background noise floor.
4. Result = Reading + Correction Factor  
 Margin = Result - Limit  
 Remark Peak = Result(PK) - Limit(PK)  
 Remark AVG = Result(AV) - Limit(AV)



<b>Product Name</b>	Computer	<b>Test By</b>	Waternil Guan
<b>Test Model</b>	POC127	<b>Test Date</b>	2015/06/18
<b>Test Mode</b>	UNII Band 3/ IEEE 802.11an HT40 TX / CH High	<b>Temp. &amp; Humidity</b>	26°C, 52%

966 Chamber\_C at 3Meter / Horizontal

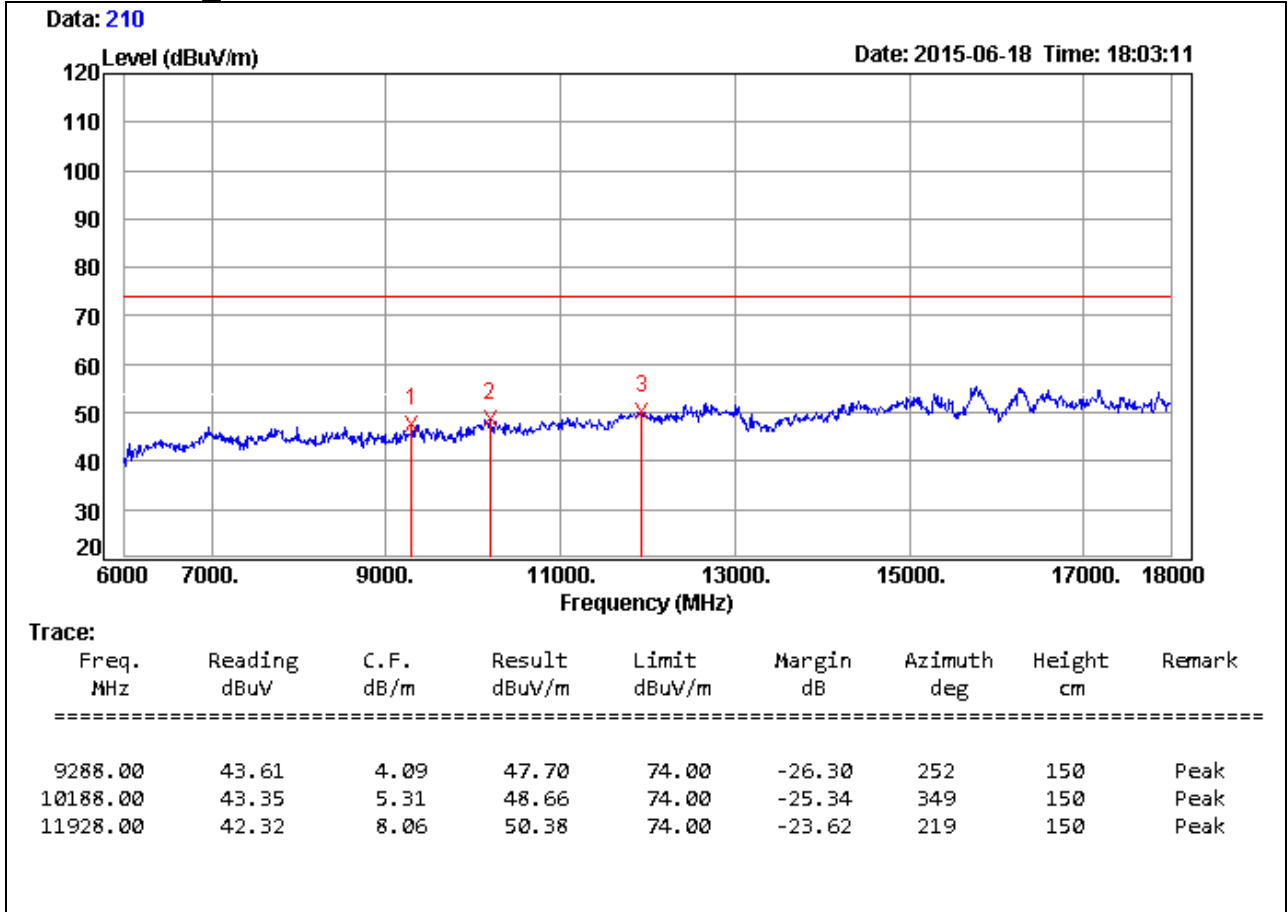

**Remark:**

1. Measuring frequencies from 1 GHz to the 10th harmonic of highest fundamental frequency.
2. Average test would be performed if the peak result were greater than the average limit.
3. Measurements above show only up to 6 maximum emissions noted, or would be lesser, with " N/A " remark, if no specific emissions from the EUT are recorded (ie: margin>20dB from the applicable limit) and considered that's already beyond the background noise floor.
4. Result = Reading + Correction Factor  
Margin = Result - Limit  
Remark Peak = Result(PK) - Limit(PK)  
Remark AVG = Result(AV) - Limit(AV)
5. There is no emission in 18GHz ~ 40GHz.

<b>Product Name</b>	Computer	<b>Test By</b>	Waternil Guan
<b>Test Model</b>	POC127	<b>Test Date</b>	2015/06/22
<b>Test Mode</b>	UNII Band 3/ IEEE 802.11an HT40 TX / CH High	<b>Temp. &amp; Humidity</b>	26°C, 52%

966 Chamber\_C at 3Meter / Vertical

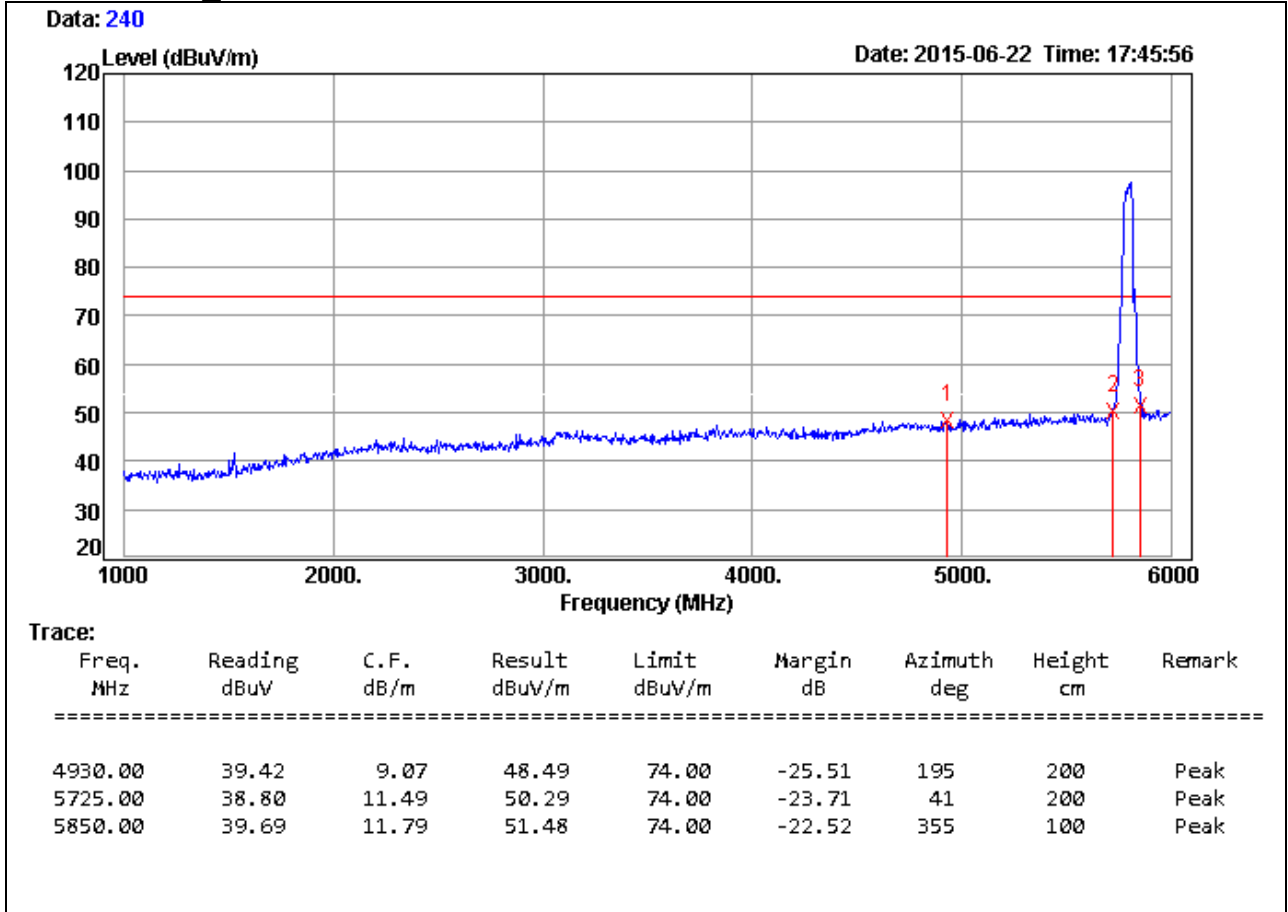

**Remark:**

1. Measuring frequencies from 1 GHz to the 10th harmonic of highest fundamental frequency.
2. Average test would be performed if the peak result were greater than the average limit.
3. Measurements above show only up to 6 maximum emissions noted, or would be lesser, with " N/A " remark, if no specific emissions from the EUT are recorded (ie: margin>20dB from the applicable limit) and considered that's already beyond the background noise floor.
4.  $Result = Reading + Correction\ Factor$   
 $Margin = Result - Limit$   
 $Remark\ Peak = Result(PK) - Limit(PK)$   
 $Remark\ AVG = Result(AV) - Limit(AV)$

<b>Product Name</b>	Computer	<b>Test By</b>	Waternil Guan
<b>Test Model</b>	POC127	<b>Test Date</b>	2015/06/18
<b>Test Mode</b>	UNII Band 3/ IEEE 802.11an HT40 TX / CH High	<b>Temp. &amp; Humidity</b>	26°C, 52%

966 Chamber\_C at 3Meter / Vertical

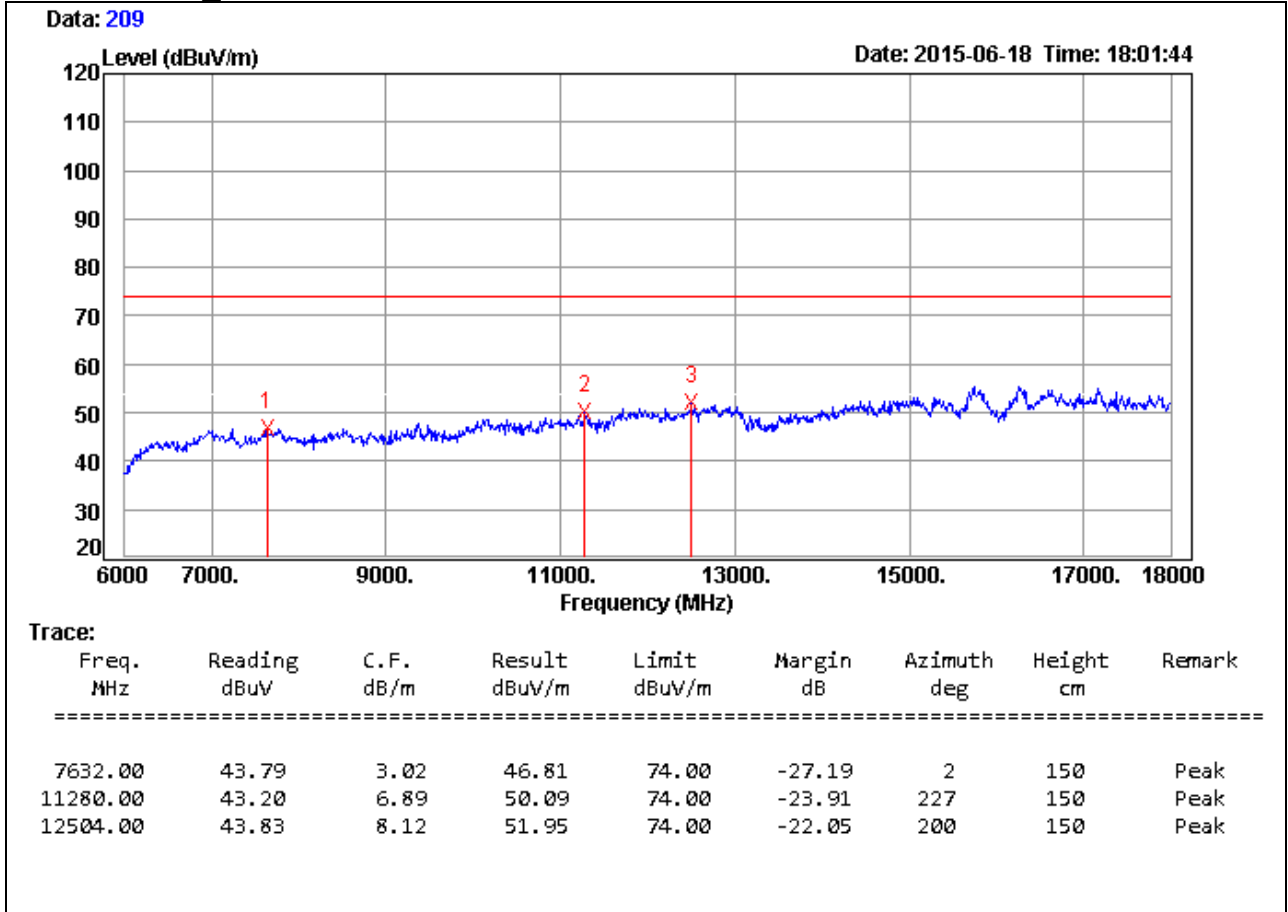

**Remark:**

1. Measuring frequencies from 1 GHz to the 10th harmonic of highest fundamental frequency.
2. Average test would be performed if the peak result were greater than the average limit.
3. Measurements above show only up to 6 maximum emissions noted, or would be lesser, with " N/A " remark, if no specific emissions from the EUT are recorded (ie: margin>20dB from the applicable limit) and considered that's already beyond the background noise floor.
4. Result = Reading + Correction Factor  
Margin = Result - Limit  
Remark Peak = Result(PK) - Limit(PK)  
Remark AVG = Result(AV) - Limit(AV)
5. There is no emission in 18GHz ~ 40GHz.



**Detector Mode : Peak Polarity : Vertical**

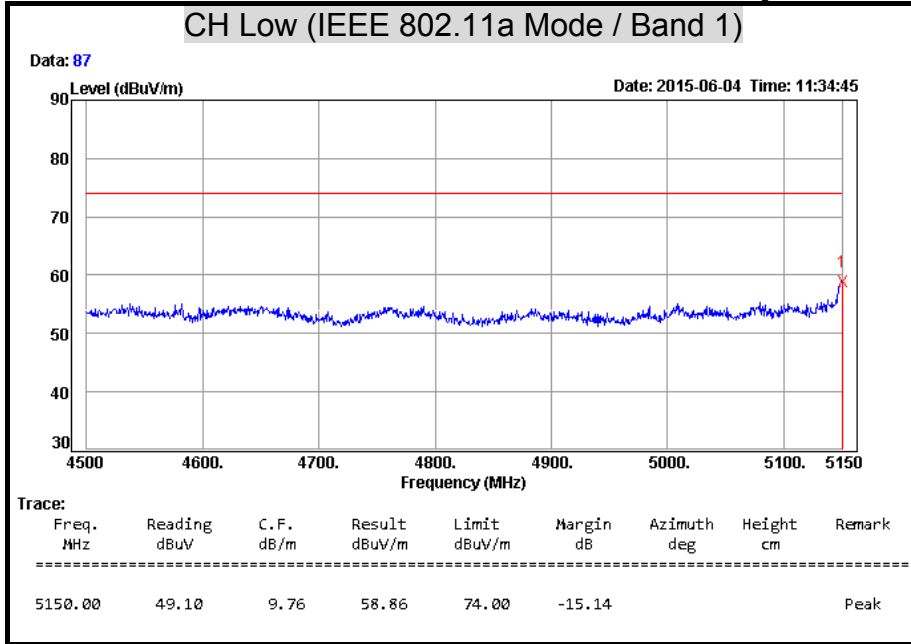

**Detector Mode : Average Polarity : Vertical**

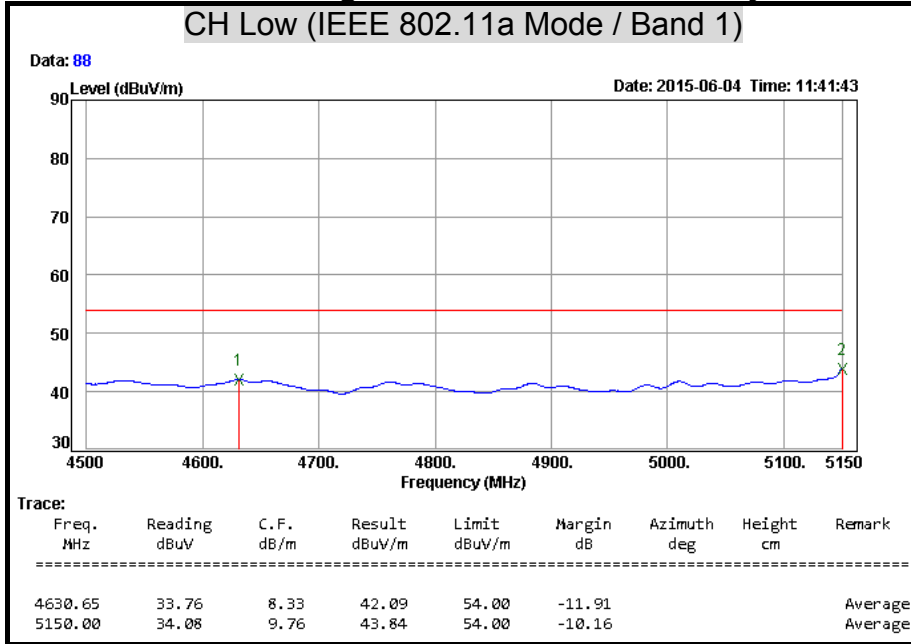



**Detector Mode : Peak Polarity : Vertical**

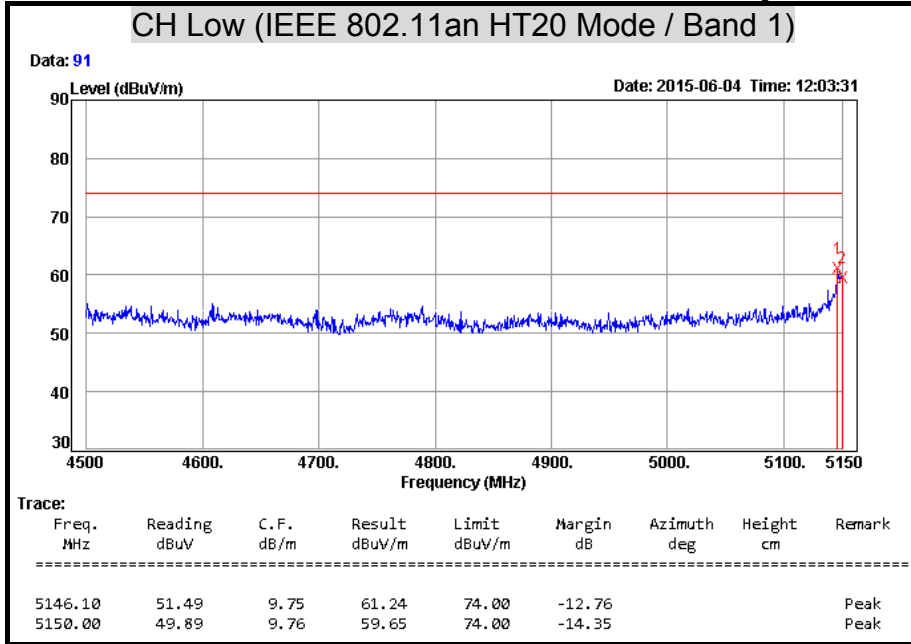

**Detector Mode : Average Polarity : Vertical**

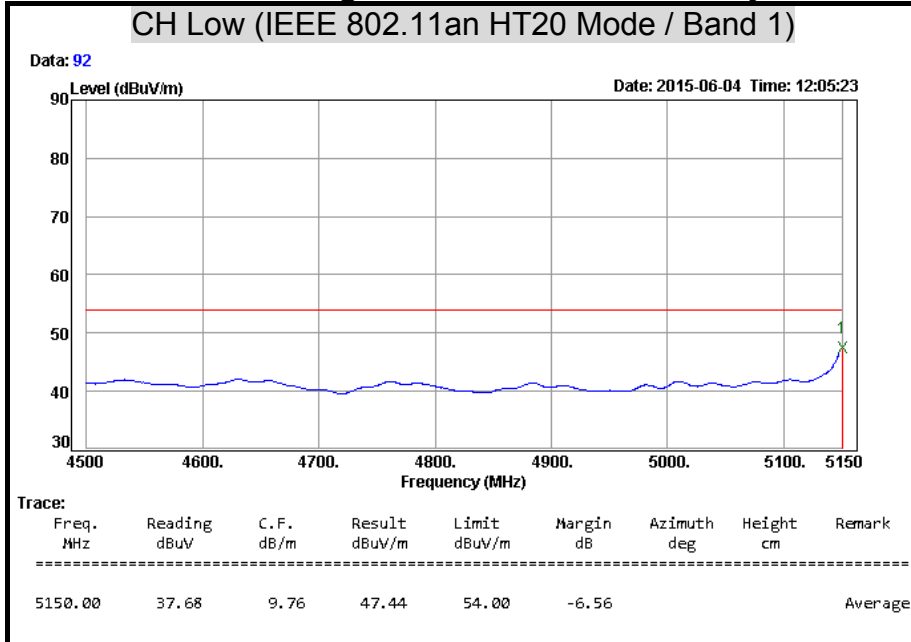

**Detector Mode : Peak**

**Polarity : Horizontal**

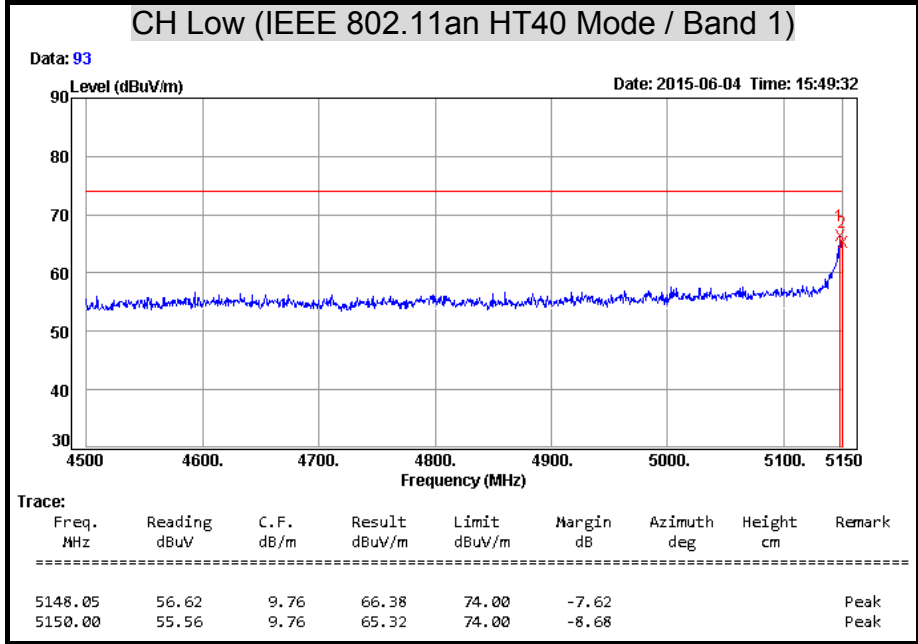

**Detector Mode : Average**

**Polarity : Horizontal**

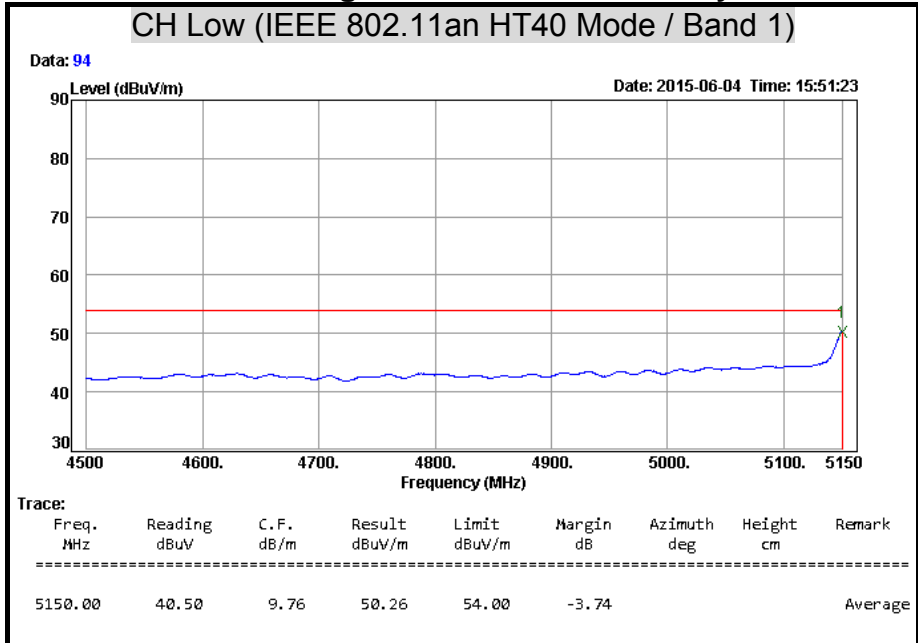



**Detector Mode : Peak** **Polarity : Vertical**

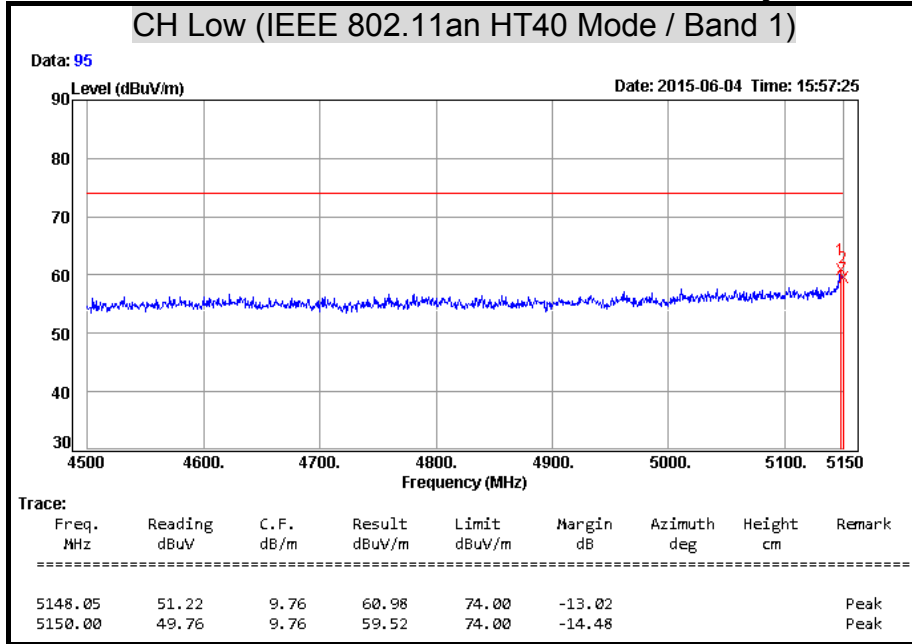

**Detector Mode : Average** **Polarity : Vertical**

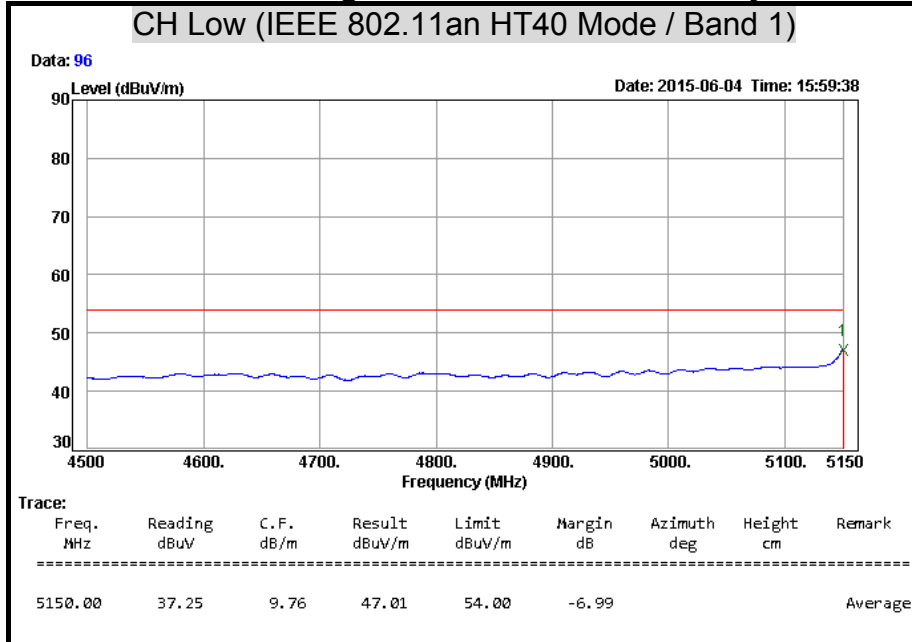

**Detector Mode : Peak**

**Polarity : Horizontal**

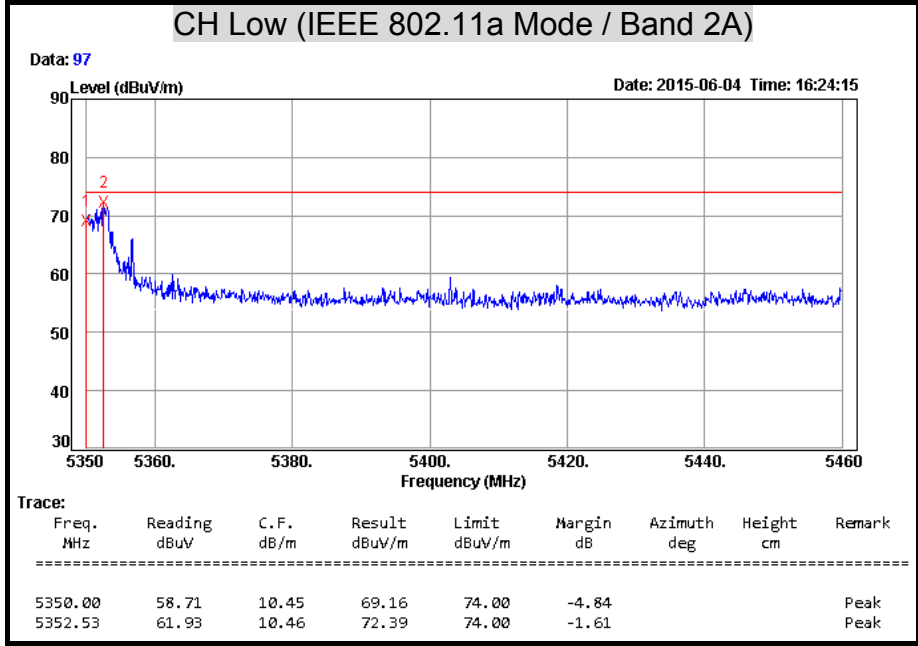

**Detector Mode : Average**

**Polarity : Horizontal**

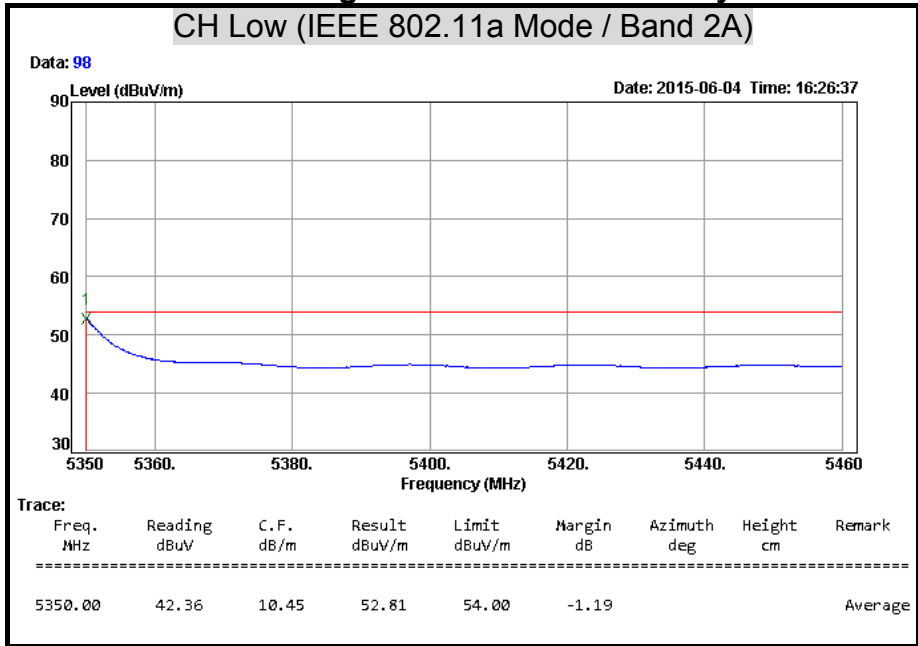

**Detector Mode : Peak Polarity : Vertical**

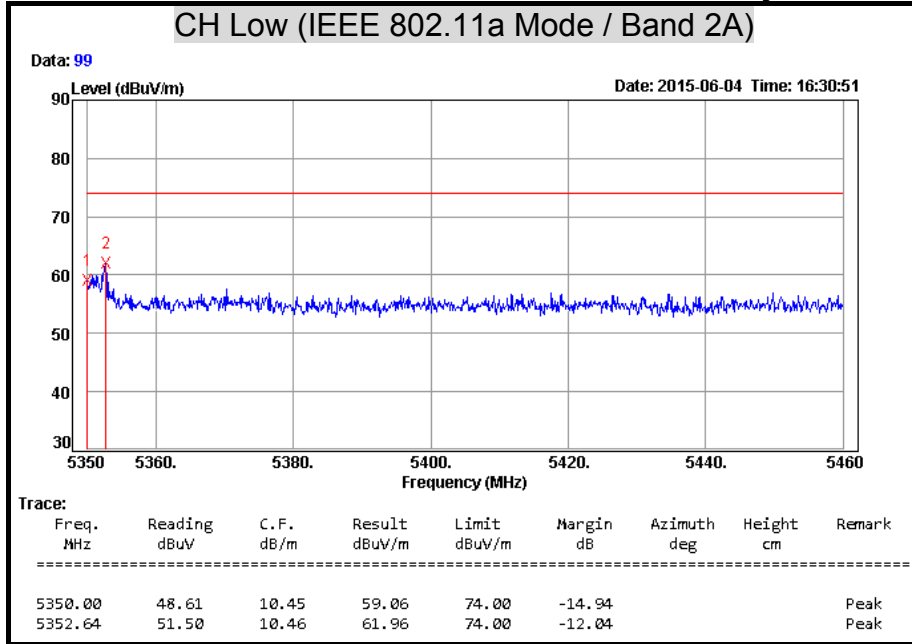

**Detector Mode : Average Polarity : Vertical**

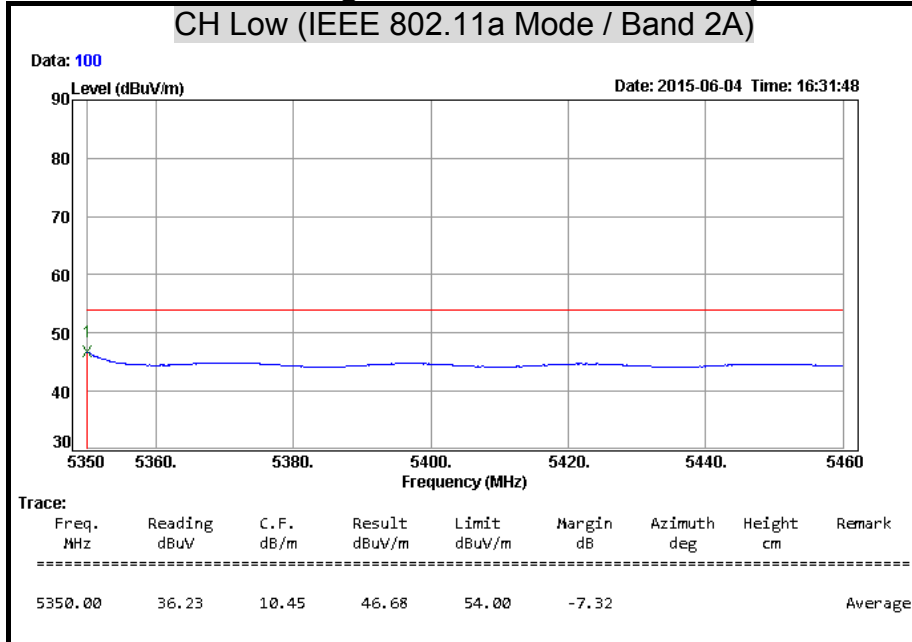

**Detector Mode : Peak**

**Polarity : Horizontal**

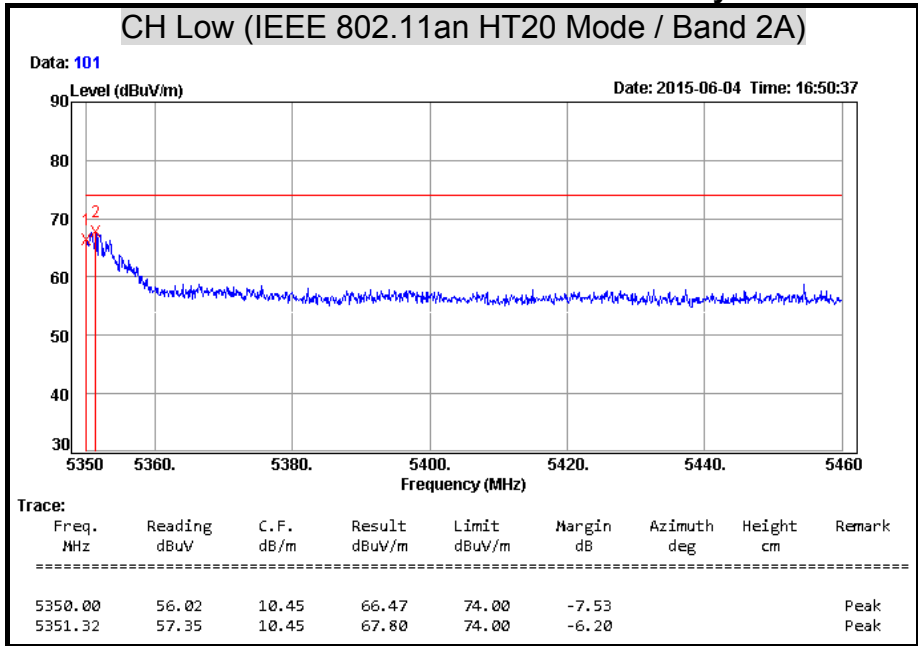

**Detector Mode : Average**

**Polarity : Horizontal**

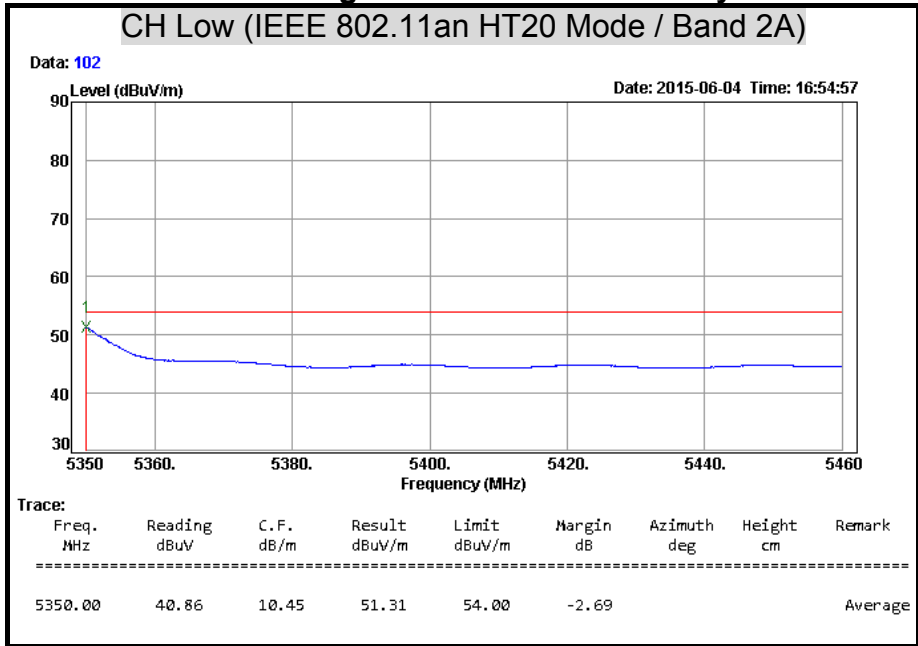

**Detector Mode : Peak Polarity : Vertical**

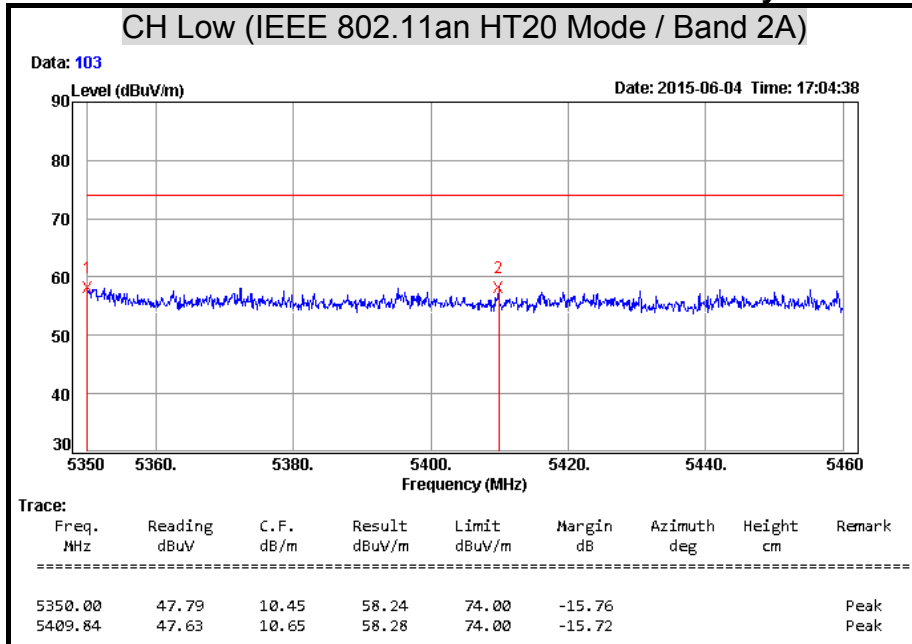

**Detector Mode : Average Polarity : Vertical**

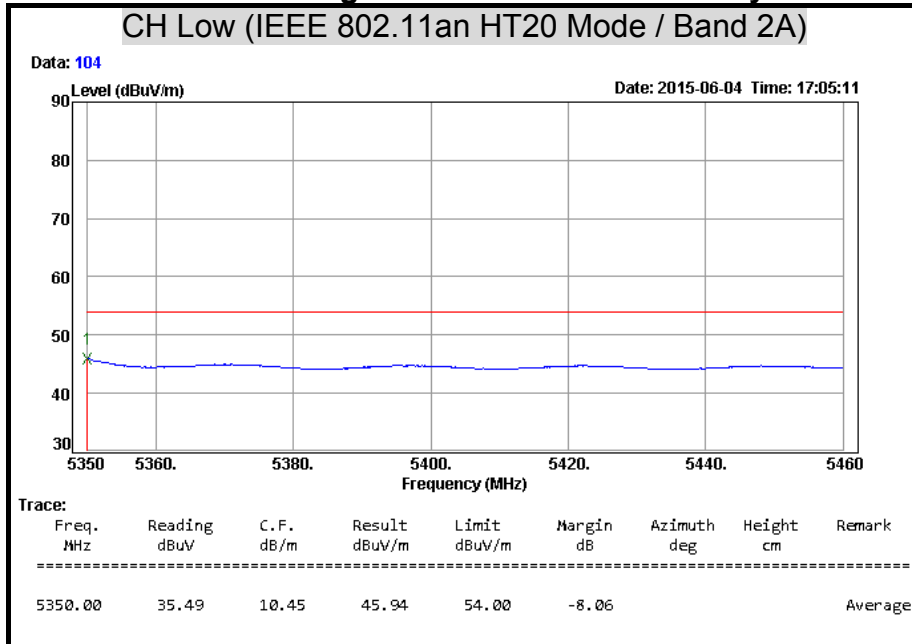

**Detector Mode : Peak**

**Polarity : Horizontal**

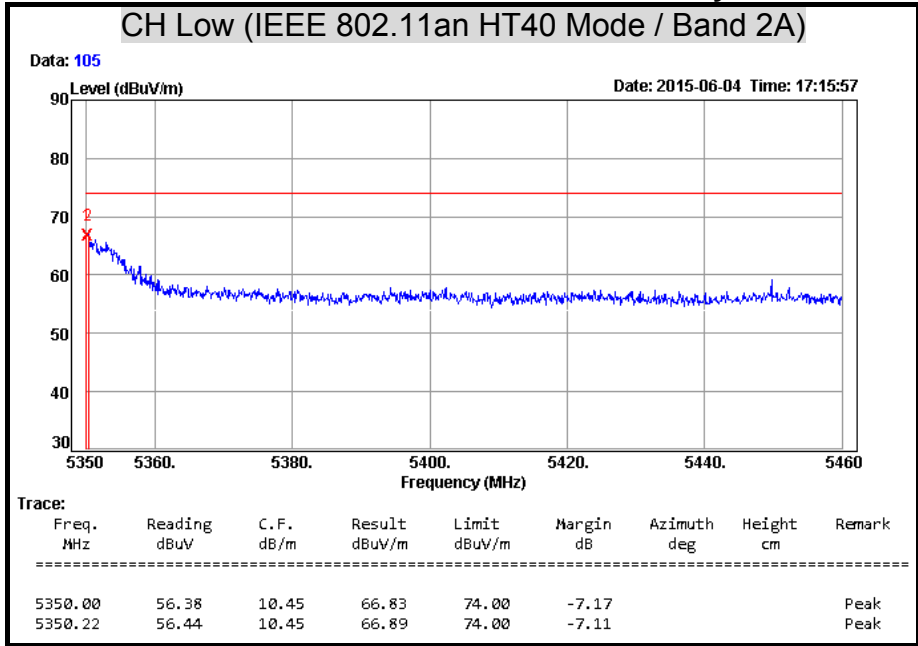

**Detector Mode : Average**

**Polarity : Horizontal**

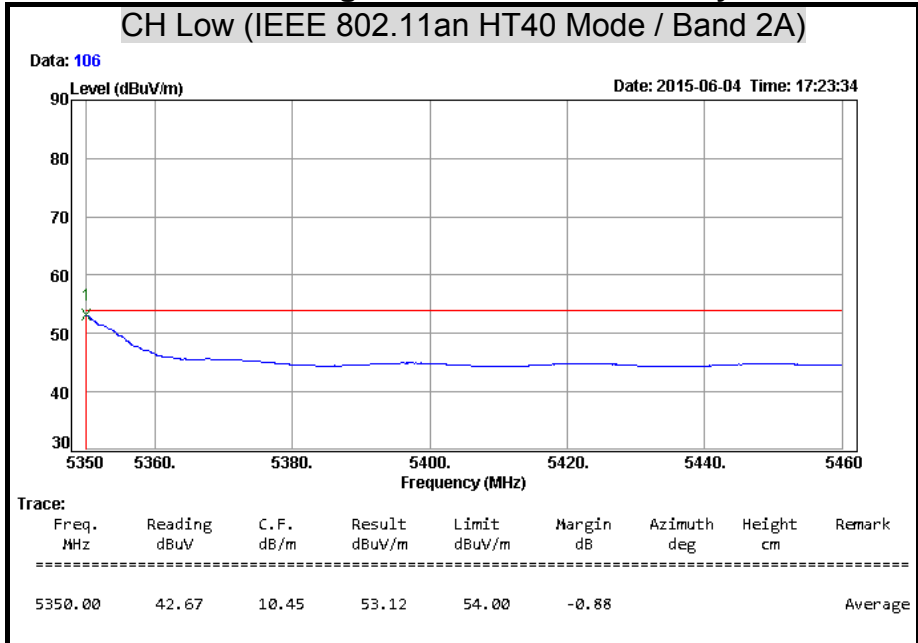

**Detector Mode : Peak**

**Polarity : Vertical**

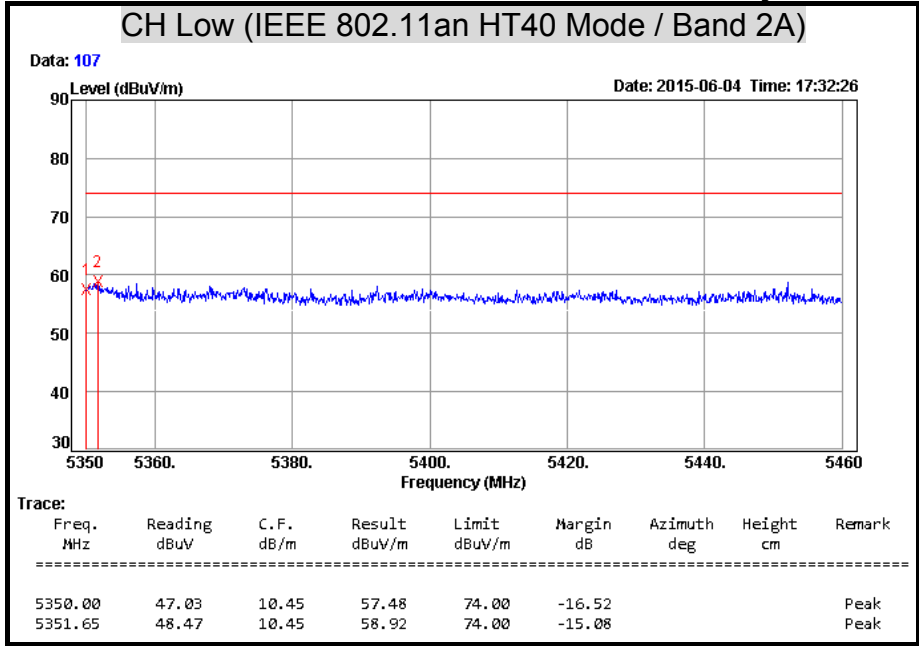

**Detector Mode : Average**

**Polarity : Vertical**

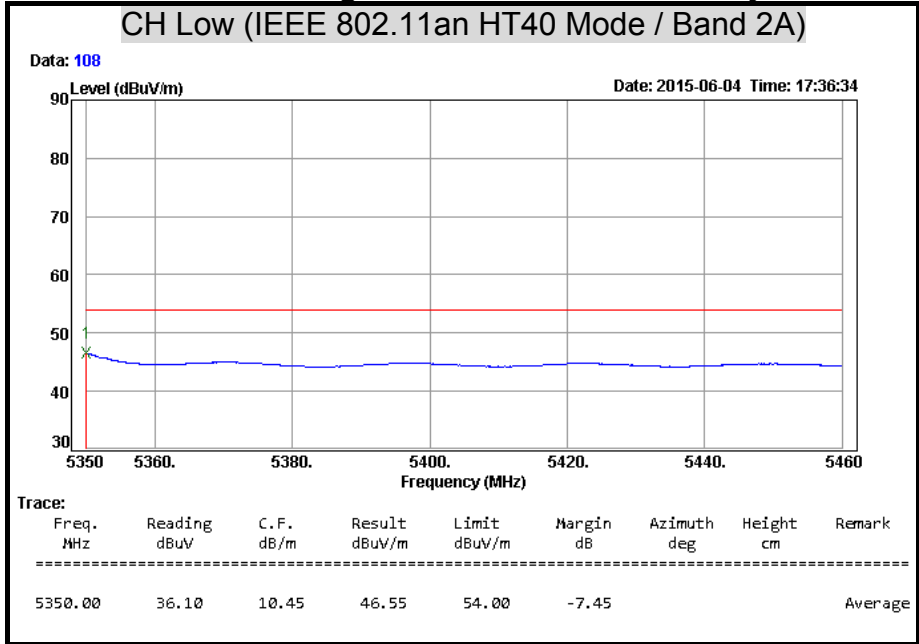

## 7.5 CONDUCTED EMISSION

### LIMITS

§ 15.207 (a) Except as shown in paragraph (b) and (c) this section, for an intentional radiator that is designed to be connected to the public utility (AC) power line, the radio frequency voltage that is conducted back onto the AC power line on any frequency or frequencies within the band 150 kHz to 30 MHz shall not exceed the limits in the following table, as measured using a 50  $\mu$ H/50 ohms line impedance stabilization network (LISN). Compliance with the provisions of this paragraph shall be based on the measurement of the radio frequency voltage between each power line and ground at the power terminal. The lower limit applies at the boundary between the frequency ranges.

Frequency Range (MHz)	Conducted Limit (dB $\mu$ v)	
	Quasi-peak	Average
0.15 - 0.50	66 to 56	56 to 46
0.50 - 5.00	56	46
5.00 - 30.0	60	50

### TEST EQUIPMENT

Name of Equipment	Manufacturer	Model	Serial Number	Calibration Due
L.I.S.N	SCHWARZBECK	NSLK 8127	8127465	08/06/2015
L.I.S.N	SCHWARZBECK	NSLK 8127	8127473	03/09/2016
EMI Receiver	ROHDE & SCHWARZ	ESCS 30	838550/003	11/02/2015
Pulse Limiter	ROHDE & SCHWARZ	ESH3-Z2	100111	06/28/2016

*Remark: Each piece of equipment is scheduled for calibration once a year.*



**TEST SETUP**

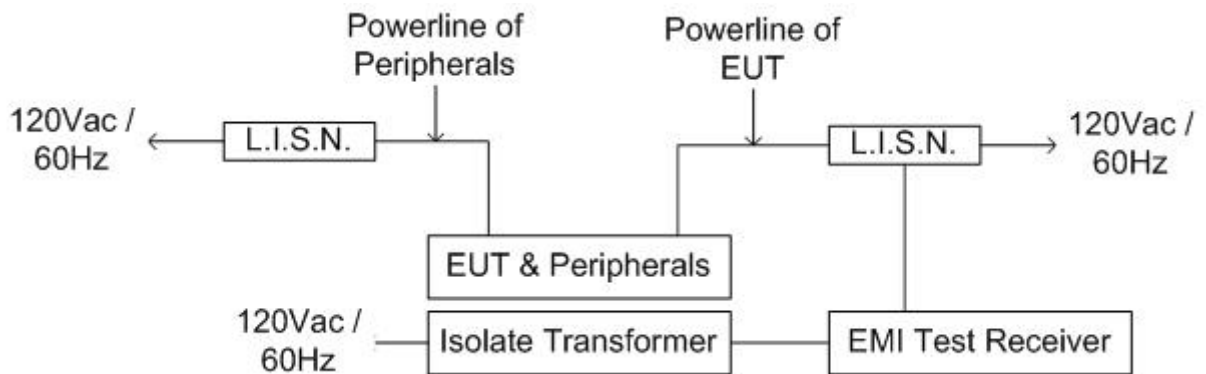
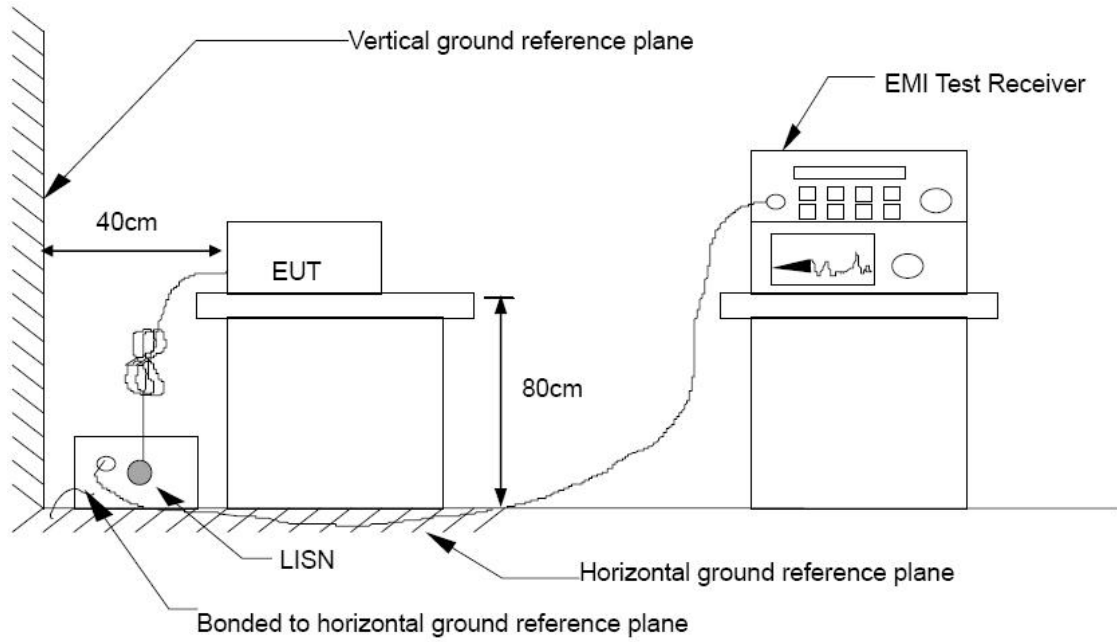

**TEST PROCEDURE**

The basic test procedure was in accordance with ANSI C63.10:2013.

The test procedure is performed in a 4m × 3m × 2.4m (L×W×H) shielded room.

The EUT along with its peripherals were placed on a 1.0m (W) × 1.5m (L) and 0.8m in height wooden table and the EUT was adjusted to maintain a 0.4 meter space from a vertical reference plane.

The EUT was connected to power mains through a line impedance stabilization network (LISN) which provides 50 ohm coupling impedance for measuring instrument and the chassis ground was bounded to the horizontal ground plane of shielded room. All peripherals were connected to the second LISN and the chassis ground also bounded to the horizontal ground plane of shielded room.

The EUT was located so that the distance between the boundary of the EUT and the closest surface of the LISN is 0.8 m. Where a mains flexible cord was provided by the manufacturer shall be 1 m long, or if in excess of 1 m, the excess cable was folded back and forth as far as possible so as to form a bundle not exceeding 0.4 m in length.

**TEST RESULTS**

<b>Product Name</b>	Computer	<b>Test By</b>	Crystal Wu
<b>Test Model</b>	POC127	<b>Test Date</b>	2015/06/25
<b>Test Mode</b>	TX Mode	<b>Temp. &amp; Humidity</b>	21.8°C, 64%

**LINE**

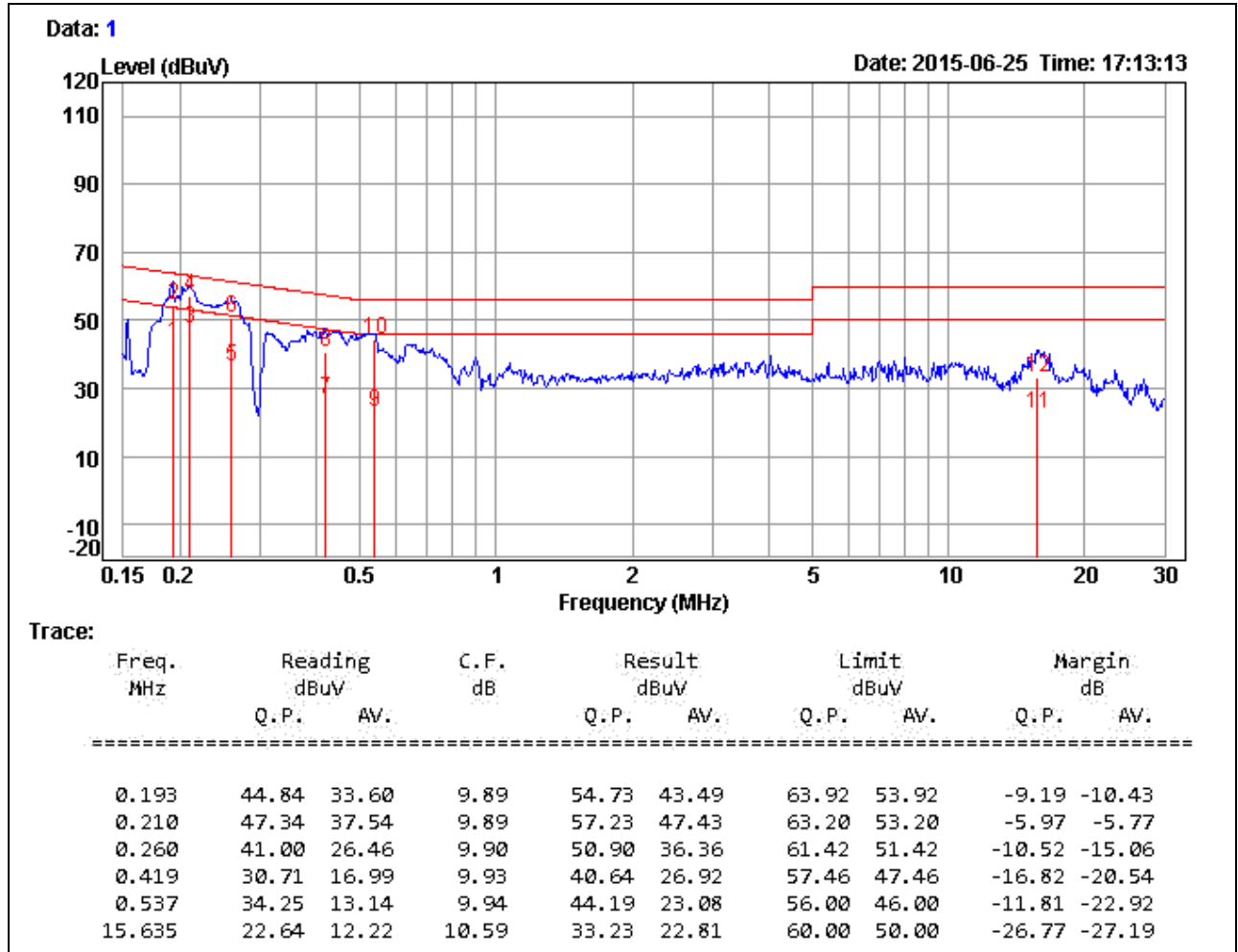

**Remark:**

1. Correction Factor = Insertion loss + Cable loss
2. Result level = Reading Value + Correction factor
3. Margin value = Result level – Limit value

<b>Product Name</b>	Computer	<b>Test By</b>	Crystal Wu
<b>Test Model</b>	POC127	<b>Test Date</b>	2015/06/25
<b>Test Mode</b>	TX Mode	<b>Temp. &amp; Humidity</b>	21.8°C, 64%

NEUTRAL

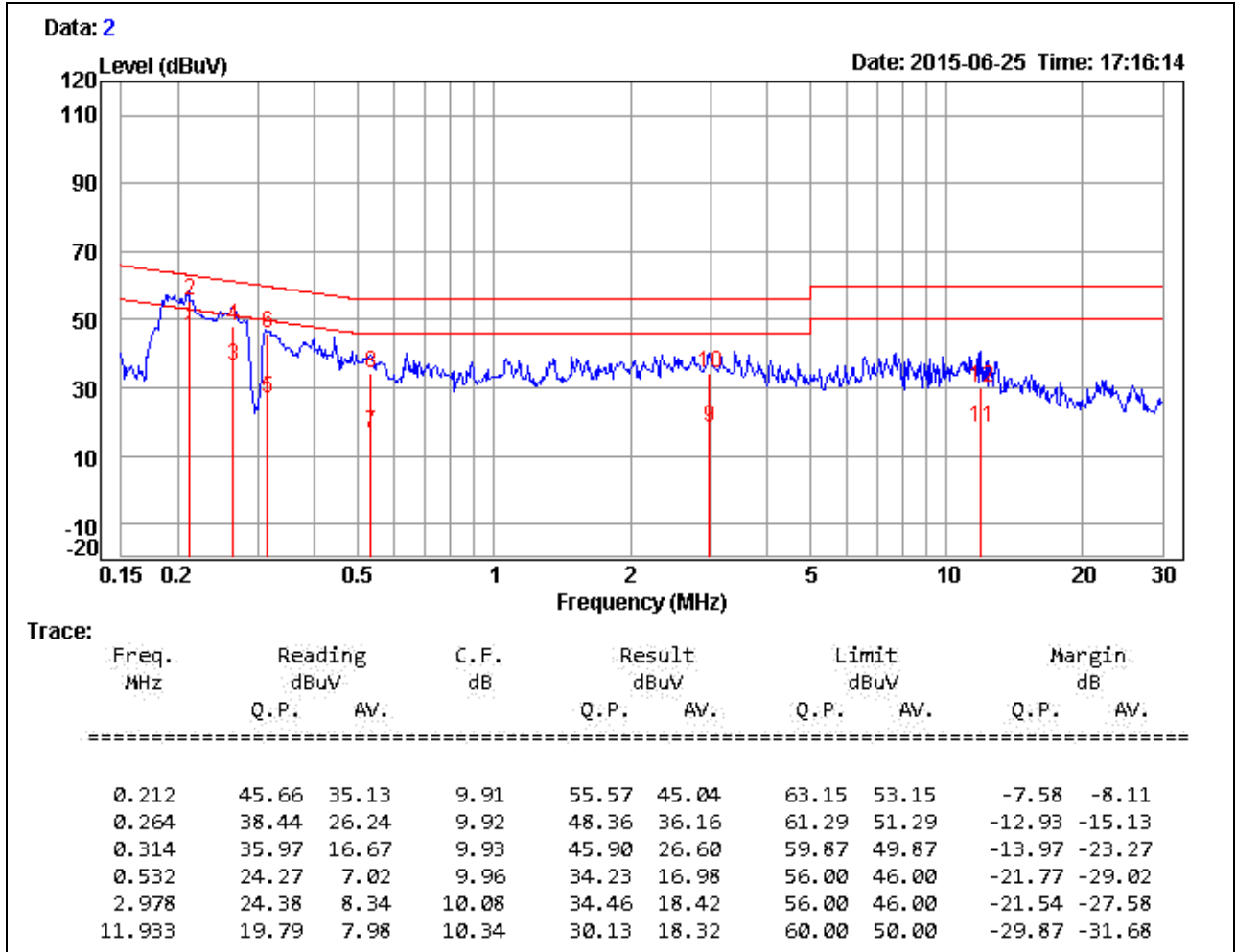

**Remark:**

1. Correction Factor = Insertion loss + Cable loss
2. Result level = Reading Value + Correction factor
3. Margin value = Result level – Limit value

## 7.6 FREQUENCY STABILITY

### LIMITS

§ 15.407 (g) manufacturers of U-NII devices are responsible for ensuring frequency stability such that an emission is maintained within the band of operation under all conditions of normal operation as specified in the user’s manual.

### TEST EQUIPMENT

Name of Equipment	Manufacturer	Model	Serial Number	Calibration Due
EXA Signal Analyzer	Agilent	N9010A	MY52220817	03/19/2016
Temp. & Humid. Chamber	TERCHY	MHC-120L	960424	09/09/2015

*Remark: Each piece of equipment is scheduled for calibration once a year.*

### TEST SETUP

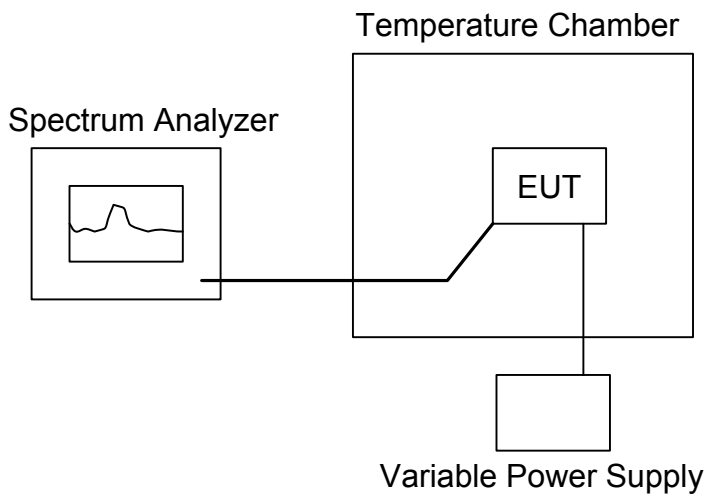

**TEST PROCEDURE**

1. Place the EUT on the table and set it in the transmitting mode.
2. Remove the antenna from the EUT and then connect a low loss RF cable from the antenna port to the spectrum analyzer.
3. Set the environment into appropriate environment.
4. Set the spectrum analyzer as RBW=1kHz, VBW = RBW, Span = 200kHz, Sweep = auto.
5. Mark the peak frequency and measure the frequency tolerance using frequency counter function.
6. Repeat until all the results are investigated.

**TEST RESULTS**

**IEEE 802.11a mode**

U-NII	Channel	Channel Frequency (MHz)	Measured Frequency (MHz)	Delta Frequency (kHz)	20 ppm Limit (kHz)	Margin (kHz)
Band 1	Low	5180	5179.981700	-18.30	103.60	-85.30
	Middle	5200	5199.981100	-18.90	104.00	-85.10
	High	5240	5239.980800	-19.20	104.80	-85.60
Band 2A	Low	5260	5259.981100	-18.90	105.20	-86.30
	Middle	5300	5299.980500	-19.50	106.00	-86.50
	High	5320	5319.980800	-19.20	106.40	-87.20
Band 2A	Low	5500	5499.980800	-19.20	110.00	-90.80
	Middle	5580	5579.979900	-20.10	111.60	-91.50
	High	5700	5699.979900	-20.10	114.00	-93.90
Band 3	Low	5745	5744.979300	-20.70	114.90	-94.20
	Middle	5785	5784.979300	-20.70	115.70	-95.00
	High	5825	5824.978700	-21.30	116.50	-95.20

**IEEE 802.11an HT20 Mode**

U-NII	Channel	Channel Frequency (MHz)	Measured Frequency (MHz)	Delta Frequency (kHz)	20 ppm Limit (kHz)	Margin (kHz)
Band 1	Low	5180	5179.980400	-19.60	103.60	-84.00
	Middle	5200	5199.979300	-20.70	104.00	-83.30
	High	5240	5239.979300	-20.70	104.80	-84.10
Band 2A	Low	5260	5259.979400	-20.60	105.20	-84.60
	Middle	5300	5299.980800	-19.20	106.00	-86.80
	High	5320	5319.980400	-19.60	106.40	-86.80
Band 2C	Low	5500	5499.980400	-19.60	110.00	-90.40
	Middle	5580	5579.980600	-19.40	111.60	-92.20
	High	5700	5699.980200	-19.80	114.00	-94.20
Band 3	Low	5745	5744.979600	-20.40	114.90	-94.50
	Middle	5785	5784.979300	-20.70	115.70	-95.00
	High	5825	5824.980300	-19.70	116.50	-96.80



**IEEE 802.11an HT40 Mode**

U-NII	Channel	Channel Frequency (MHz)	Measured Frequency (MHz)	Delta Frequency (kHz)	20 ppm Limit (kHz)	Margin (kHz)
Band1	Low	5190	5189.981100	-18.90	103.80	-84.90
	High	5230	5229.980800	-19.20	104.60	-85.40
Band 2A	Low	5270	5269.980500	-19.50	105.40	-85.90
	High	5310	5309.980200	-19.80	106.20	-86.40
Band 2C	Low	5510	5509.979300	-20.70	110.20	-89.50
	High	5550	5549.979300	-20.70	111.00	-90.30
Band 3	Low	5670	5669.978700	-21.30	113.40	-92.10
	High	5755	5754.979000	-21.00	115.10	-94.10