

FCC TEST REPORT

according to

FCC Rules and Regulations

Part 15 Subpart E

Applicant	: Advantech CO., Ltd.
Address	: No.1, Alley20, Lane 26, Rueiquang Road, Neihu District, Taipei, Taiwan 114, R.O.C.
Equipment	: Industrial Tablet PC
Model No.	: MARS-3100S
FCC ID	: M82-M31S01
Trade Name	: ADVANTECH

Laboratory accreditation



- The test result refers exclusively to the test presented test model / sample.,
- Without written approval of **Exclusive Certification Corp.** the test report shall not be reproduced except in full.
- The EUT is also considered as a kind of computer peripheral, because the connection to computer is necessary for typical use. It has been verified to comply with the requirements of FCC Part 15, Subpart B, Class B (DoC). The test report has been issued separately.

CONTENTS

1.	Report of Measurements and Examinations.....	5
1.1.	List of Measurements and Examinations	5
2.	Test Configuration of Equipment under Test.....	6
2.1.	Feature of Equipment under Test.....	6
2.2.	RF Specifications	7
2.3.	Test Mode & Test Software	8
2.4.	Description of Test System.....	8
2.5.	Connection Diagram of Test System.....	9
2.6.	Carrier Frequency of Channels.....	10
2.7.	General Information of Test.....	11
2.8.	Measurement Uncertainty	11
2.9.	History of this test report	12
3.	Antenna Requirements	13
3.1.	Standard Applicable	13
3.2.	Antenna Construction and Directional Gain.....	13
4.	Test of Conducted Emission	14
4.1.	Test Procedures	14
4.2.	Typical Test Setup Layout of Conducted Emission.....	15
4.3.	Conducted Emission Requirement	15
4.4.	Measurement equipment	15
4.5.	Test Result and Data.....	16
4.6.	Test Photographs	18
5.	Test of Radiated Emission	19
5.1.	Test Procedures	19
5.2.	Typical Test Setup Layout of Radiated Emission.....	20
5.3.	Measurement equipment	20
5.4.	Test Result and Data.....	21
5.5.	Test Photographs	31
6.	Peak Transmit Power.....	32
6.1.	Test Procedure	32
6.2.	Test Setup Layout	32
6.3.	Measurement equipment	32
6.4.	Test Result and Data.....	32
7.	Peak Power Excursion.....	37
7.1.	Test Procedure	37
7.2.	Test Setup Layout	37
7.3.	Measurement equipment	37
7.4.	Test Result and Data.....	37
8.	Peak Power Spectral Density.....	40
8.1.	Test Procedure	40
8.2.	Test Setup Layout	40
8.3.	Measurement equipment	40
8.4.	Test Result and Data.....	40
9.	Frequency Stability.....	43
9.1.	Test Procedure	43
9.2.	Test Setup Layout	43

9.3. Measurement equipment43

9.4. Test Result and Data44

10. Band Edges Measurement45

10.1. Test Procedure45

10.2. Measurement equipment45

10.3. Test Result and Data45

10.4. Restrict Band Emission Measurement Data47

11. Restricted Bands of Operation.....48

11.1. Labeling Requirement48

12. RF Exposure49

12.1. Limit for Maximum Permissible Exposure (MPE)49

12.2. MPE Calculations.....50

12.3. FCC Radiation Exposure Statement50

Appendix A. Photographs of EUT.....A1 ~ A26

CERTIFICATE OF COMPLIANCE

according to

FCC Rules and Regulations

Part 15 Subpart E

Applicant	:	Advantech CO., Ltd.
Address	:	No.1, Alley20, Lane 26, Rueiquang Road, Neihu District, Taipei, Taiwan 114, R.O.C.
Equipment	:	Industrial Tablet PC
Model No.	:	MARS-3100S
FCC ID	:	M82-M31S01

I HEREBY CERTIFY THAT :

The measurements shown in this test report were made in accordance with the procedures given in **ANSI C63.4** The equipment was **passed** the test performed according to **FCC Rules and Regulations Part 15 Subpart E (2003)**.

The test was carried out on Feb. 29, 2008 at **Exclusive Certification Corp.**

Signature

Anson Chou / Manager

1. Report of Measurements and Examinations

1.1. List of Measurements and Examinations

For Frequency 5.15GHz ~ 5.25GHZ

Applied Standard : FCC Part 15, Subpart E (Section 15.407)		
FCC Rule	Description of Test	Result
15.407(b)(5)	. Conducted Emission	Pass
15.407(b/1/2/3)(b)(5)	. Radiated Emission	Pass
15.407(a/1/2/3)	. Peak Transmit Power	Pass
15.407(a)(6)	. Peak Power Excursion	Pass
15.407(a/1/2/3)	. Peak Power Spectral Density	Pass
15.407(g)	. Frequency Stability	Pass

2. Test Configuration of Equipment under Test

2.1. Feature of Equipment under Test

OS	MS XP Embedded
Dimension W x D x H	293 x 210 x 38 mm
Weight	2.1 kg
Panel	10.4" SVGA TFT
Touchscreen	Resistant touchscreen
CPU	AMD LX800 500MHz
DRAM	256/512MB DDR400 (One memory module support)
L2 cache	128 K
Chipset	AMD CS5536
Graphic	AMD LX800 with shared memory
Storage	4G CF (2.5" shock mounted HDD option)
Keypad	5-way navigation key; 3 x function key (programmable)
Wireless	802.11 a/b/g
PAN	Bluetooth V2.0/EDR (optional)
Microphone Jack	Yes
Headset Jack	Yes
RS232	Yes (COM3)
USB	USB2.0 x 1
RJ-45	10/100 Base-T
DC-in	Yes
VGA D_sub connector	Yes
Docking / Port Replicator	Yes
AC97 Audio I/F	AC97 Audio I/F
Speaker	One integrated speaker
Battery	Removable 11.1V@3600mAh Li-ion battery pack; swappable
Battery Life	3 hour battery life
Charging Time	2.5 hours to 90%
Backup Battery	7.2V, 120mAh
Adapter	Auto-switching 100-240V, 50-60Hz; supplies 19VDC at 3.42A

2.2. RF Specifications

Type of Modulation	802.11b: DSSS (CCK, DQPSK, DBPSK) 802.11g: OFDM (64-QAM, 16-QAM, QPSK, BPSK) 802.11a: OFDM BT: GFSK, $\pi/4$ -DQPSK, 8DPSK
Data Rate	802.11b(11, 5.5, 2, 1 Mbps) 802.11g(54 Mbps, 48 Mbps, 36 Mbps, 24 Mbps, 18 Mbps, 12 Mbps, 9 Mbps, 6 Mbps) 802.11a(54 Mbps, 48 Mbps, 36 Mbps, 24 Mbps, 18 Mbps, 12 Mbps, 9 Mbps, 6 Mbps) 802.11BT(3Mbps, 2Mbps, 1Mbps)
Number of Channels	Number of Channels 802.11b / 802.11g USA, Canada and Taiwan: 1 ~ 11 (11 Channels) Most European Countries: 1 ~ 13 (13 Channels) France: 1 ~ 7 (7 Channels) 802.11a USA, Canada and Taiwan: 36 ~ 48, 149 ~ 165 (9 Channels) Most European Countries: 36 ~ 64, 100 ~ 140 (19 Channels) BT: 0 ~ 78 (79 Channels)
Frequency Band	USA, Canada and Taiwan: 802.11b/g, BT: 2.4 ~ 2.4835GHz 802.11a: 5.15 ~ 5.25GHz, 5.725 ~ 5.85GHz Most European Countries: 802.11b/g, BT: 2.4 ~ 2.4835GHz 802.11a: 5.15 ~ 5.35GHz, 5.47 ~ 5.725GHz
Carrier Frequency of each channel	802.11b / 802.11g US: 2412 + 5 * K MHz; K = 0 ~ 10 EU: 2412 + 5 * K MHz; K = 0 ~ 12 France: 2412 + 5 * K MHz; K = 0 ~ 6 802.11a US : 5150 ~ 5250: 5180 + 20 K MHz; K = 0 ~ 3 5725 ~ 5850: 5745 + 20 K MHz; K = 0 ~ 4 EU: 5150 ~ 5250: 5180 + 20 K MHz; K = 0 ~ 7 5470 ~ 5725: 5500 + 20 K MHz; K = 0 ~ 10 BT: 2402 + K MHz; K = 0 ~ 78
Channel Spacing	802.11b/g: 5MHz ; 802.11a: 20MHz ; BT: 1MHz
Output Power	Max. Peak Output power (FCC): 802.11b: 18 dBm; 802.11g: 15 dBm; 802.11a: 13 dBm; BT: 0 dBm E.I.R.P (CE) 802.11b: 17 dBm; 802.11g: 14 dBm 802.11a: 12 dBm; BT: 0 dBm
Antenna Type	GPRS + WL Antenna (AT103-105) PCB Antenna (GB04001-A01)
Antenna Gain	AT103-105 (WLAN) 1.54 dBi (2.4GHz) 1.74 dBi (5GHz) GB04001-A01 (BT) 2.2 dBi

2.3. Test Mode & Test Software

- a. During testing, the interface cables and equipment positions were varied according to ANSI C63.4
- b. The complete test system included the remote workstation, Monitor, Modem, Flash Memory, Earphone and EUT for EMC test. The remote workstation means Toshiba Notebook.
- c. An executive program, EMITEST.exe under WIN XP, which generates a complete line of continuously repeating "H" pattern was used as the test software.

The program was executed as follows:

1. Turn on the power of all equipment.
 2. The EUT reads the test program from the hard disk drive and runs it.
 3. The EUT sends "H" messages to the monitor, and the monitor displays "H" patterns on the screen.
 4. The PC sends "H" messages to the modem.
 5. The PC sends "H" messages to the internal Hard Disk, and the Hard Disk reads and writes the message.
 6. Repeat the steps from 2 to 5.
- d. An executive program, QATEST.exe under WIN XP, which generates a continuous signal by the following frequency to test.
 - 802.11b:
 - CH 36: 5180MHz, CH 44: 5220MHz, CH 48: 5240MHz
 - e. The device will automatically discontinue transmission, when the transmitting or operating stop.

Note: All the transmitter rates had been pre-tested, and the test data is worst case.

2.4. Description of Test System

Device	Manufacturer	Model No.	Description
Monitor	SlimAGE	IGV	Power Cable, Adapter Unshielding 1.8 m Data Cable, VGA Shielding 1.35 m
Modem	ACEXX	DM-1414	Power Cable, Adapter Unshielding 1.8 m Data Cable, RS232 Shielding 1.35 m
Flash memory	TranSend	JF150 512MB	N/A
Earphone	MIC	MIC-4	Data Cable, Audio Shielding 1.6 m
SIM Card	N/A	N/A	N/A
CF Card	TranScend	4GB	N/A
Notebook (Remote workstation)	TOSHIBA	PSA50T-05M00C	Power Cable, Adapter Unshielding 1.8 m
AP Router (Remote Workstation)	Netgear	WAG102	Power Cable, Adapter Unshielding 1.8 m

Use Cable:

Cable	Quantity	Description
RJ45	1	Unshielding, 5.0m

2.5. Connection Diagram of Test System

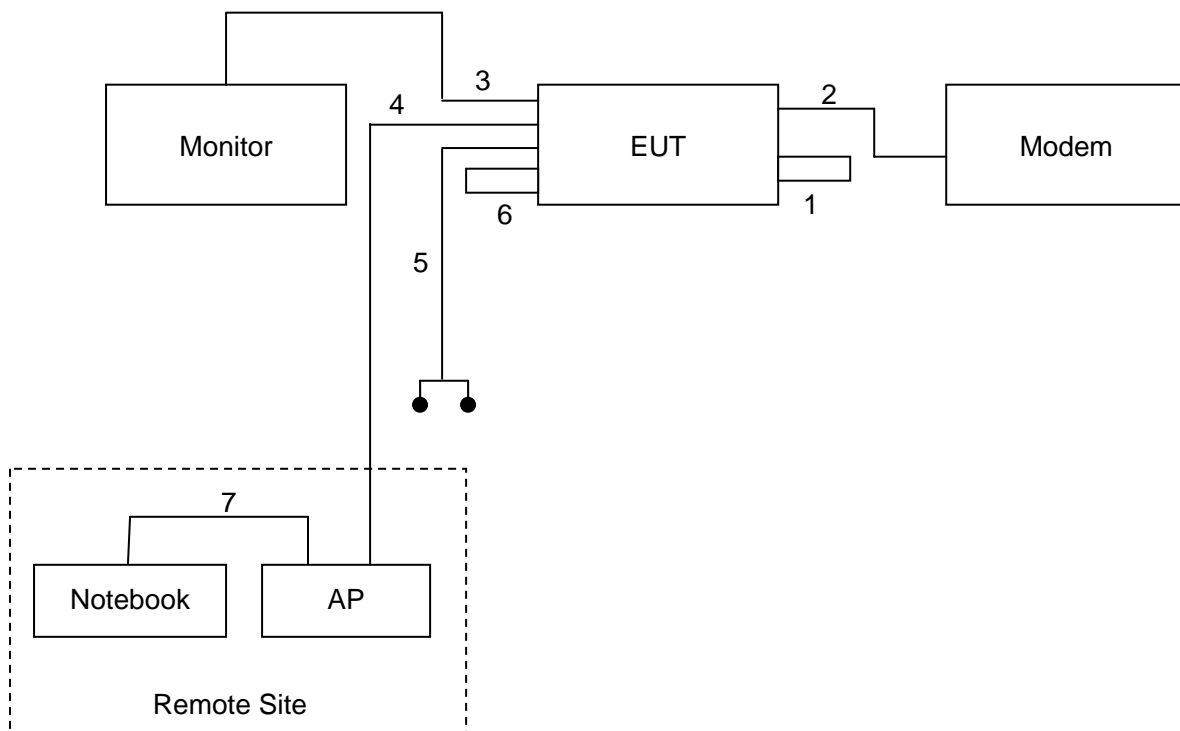

1. The SIM Card is connected to EUT by SIM slot.
2. The RS232 cable is connected from EUT to the Modem.
3. The VGA cable is connected from EUT to the Monitor.
4. The RJ45 cable is connected from EUT to the AP.
5. The Audio cable is connected from EUT to the Earphone.
6. The Flash Memory is connected to EUT by USB Port.
7. The RJ45 cable is connected from Notebook to the AP.

2.6. Carrier Frequency of Channels

802.11b/g

Channel	Frequency(MHz)	Channel	Frequency(MHz)
01	2412	08	2447
02	2417	09	2452
03	2422	10	2457
04	2427	11	2462
05	2432	---	---
06	2437	---	---
07	2442	---	---

802.11a (5150 ~ 5250MHz, 5725 ~ 5825MHz)

Channel	Frequency(MHz)	Channel	Frequency(MHz)
36	5180	149	5745
40	5200	153	5765
44	5220	157	5785
48	5240	161	5805
---	---	165	5825

2.7. General Information of Test

Test Site:	Exclusive Certification Corp. 4F-2, No. 28, Lane 78, Xing-Ai Rd. Nei-hu, Taipei City 114 Taiwan R.O.C.
Test Site Location (OATS1-SD):	No.68-1, Shihbachongsi, shihding Township, Taipei City 223, Taiwan, R.O.C.
FCC Registration Number :	632249
IC Registration Number :	6597A-1
VCCI Registration Number :	T-338 for Telecommunication Test C-2188 for Conducted emission test R-1902 for Radiated emission test
Test Voltage:	AC 120V/ 60Hz
Test in Compliance with:	ANSI C63.4-2003 FCC Part 15 Subpart E
Frequency Range Investigated:	AC Power Conducted Emission : from 150kHz to 30 MHz Radiated and conducted Emission: from 30 MHz to 40 GHz
Test Distance:	The test distance of radiated emission from antenna to EUT is 3 M.

2.8. Measurement Uncertainty

Measurement Item	Measurement Frequency	Polarization	Uncertainty
Conducted Emission	9 kHz ~ 30 MHz	LINE/NEUTRAL	2.71 dB
Radiated Emission	30 MHz ~ 1GHz	Vertical	4.11 dB
		Horizontal	4.10 dB
6 dB Bandwidth	---	---	7500 Hz
Maximum Peak Output Power	---	---	1.4 dB
100kHz Bandwidth of Frequency Band Edges	---	---	2.2 dB
Power Spectral Density	---	---	2.2 dB

2.9. History of this test report

ORIGINAL.

Additional attachment as following record:

Attachment No.	Issue Date	Description

3. Antenna Requirements

3.1. Standard Applicable

For intentional device, according to FCC 47 CFR Section 15.203, an intentional radiator shall be designed to ensure that no antenna other than that furnished by the responsible party shall be used with the device.

And according to FCC 47 CFR Section 15.247 (b), if transmitting antennas of directional gain greater than 6dBi are used, the power shall be reduced by the amount in dB that the directional gain of the antenna exceeds 6dBi.

3.2. Antenna Construction and Directional Gain

Antenna 1 (WLAN Antenna):

Antenna Model: AT103-105

Antenna type: GPRS + WL Antenna

Antenna Gain: 1.54 dBi for 2.4GHz Band / 1.74 dBi for 5GHz Band.

Antenna 2 (BT Antenna):

Antenna Model: GB04001-A01

Antenna type: PCB Antenna

Antenna Gain: 2.2 dBi

4. Test of Conducted Emission

Conducted Emissions were measured from 150 kHz to 30 MHz with a bandwidth of 9 KHz on the 120 VAC power and return leads of the EUT according to the methods defined in ANSI C63.4-2003 Section 3.1. The EUT was placed on a nonmetallic stand in a shielded room 0.8 meters above the ground plane as shown in section 1.3.1. The interface cables and equipment positioning were varied within limits of reasonable applications to determine the position produced maximum conducted emissions.

4.1. Test Procedures

- a. The EUT was placed 0.4 meter from the conducting wall of the shielding room was kept at least 80 centimeters from any other grounded conducting surface.
- b. Connect EUT to the power mains through a line impedance stabilization network (LISN).
- c. All the support units are connecting to the other LISN.
- d. The LISN provides 50 ohm coupling impedance for the measuring instrument.
- e. The FCC states that a 50 ohm, 50 micro-Henry LISN should be used.
- f. Both sides of AC line were checked for maximum conducted interference.
- g. The frequency range from 150 kHz to 30 MHz was searched.
- h. Set the test-receiver system to Peak Detect Function and Specified Bandwidth with Maximum Hold Mode.

4.2. Typical Test Setup Layout of Conducted Emission

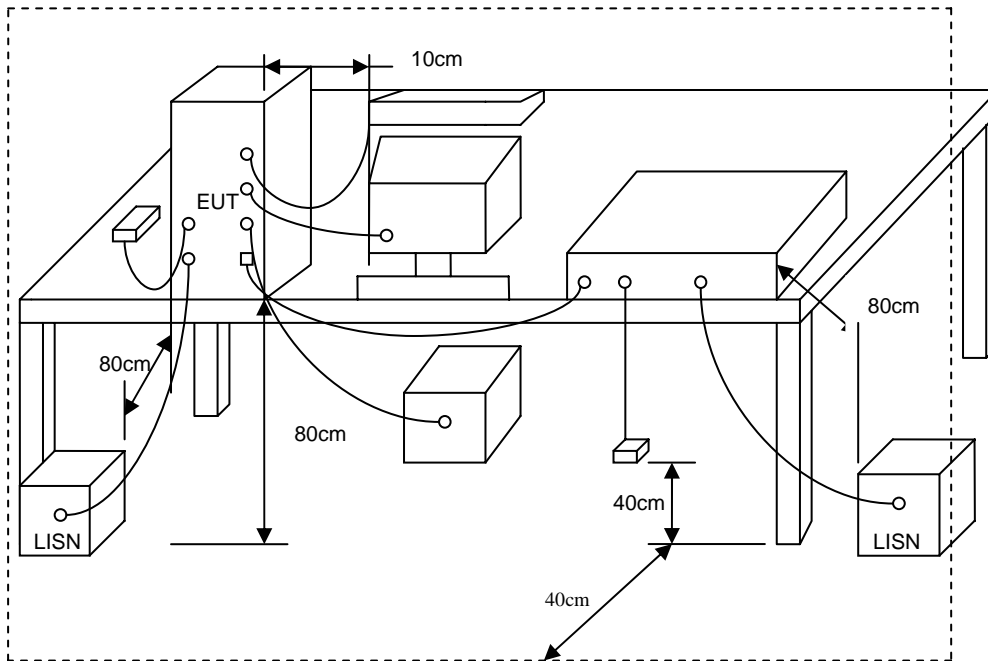

4.3. Conducted Emission Requirement

Except for A digital devices, for equipment that is designed to be connected to the public utility (AC) power line on any frequency voltage that is conducted back onto the AC power line on ant frequency or frequencies within the band 150KHz to 30MHz shall not exceed the limits in the following table, as measured using a 50μH/50 ohms line impeddance stabilization network (LISN). Compliance with the provisions of this paragraph shall be based on the measurement of the Radio frequency voltage between each power line and ground at the power terminal. The lower limit applies at the band edges.

Frequency (MHz)	Quasi Peak (dB μ V)	Average (dB μ V)
0.15 – 0.5	66-56*	56-46*
0.5 – 5.0	56	46
5.0 – 30.0	60	50

4.4. Measurement equipment

Instrument/Ancillary	Model No.	Manufacturer	Serial No.	Calibration Date	Valid Date.
Receiver	R&S	ESCI	100443	2007/09/27	2008/09/26
LISN	MESS TEC	NNB-2/16Z	02/10191	2007/05/14	2008/05/13
LISN	Rolf Heine	NNB-2/16Z	03/10058	2007/04/19	2008/04/18

4.5. Test Result and Data

Power	: AC 120V	Pol/Phase	: LINE
Test Mode	: 802.11a CH36	Temperature	: 24 °C
Memo	: LE-9702B-01	Humidity	: 58 %

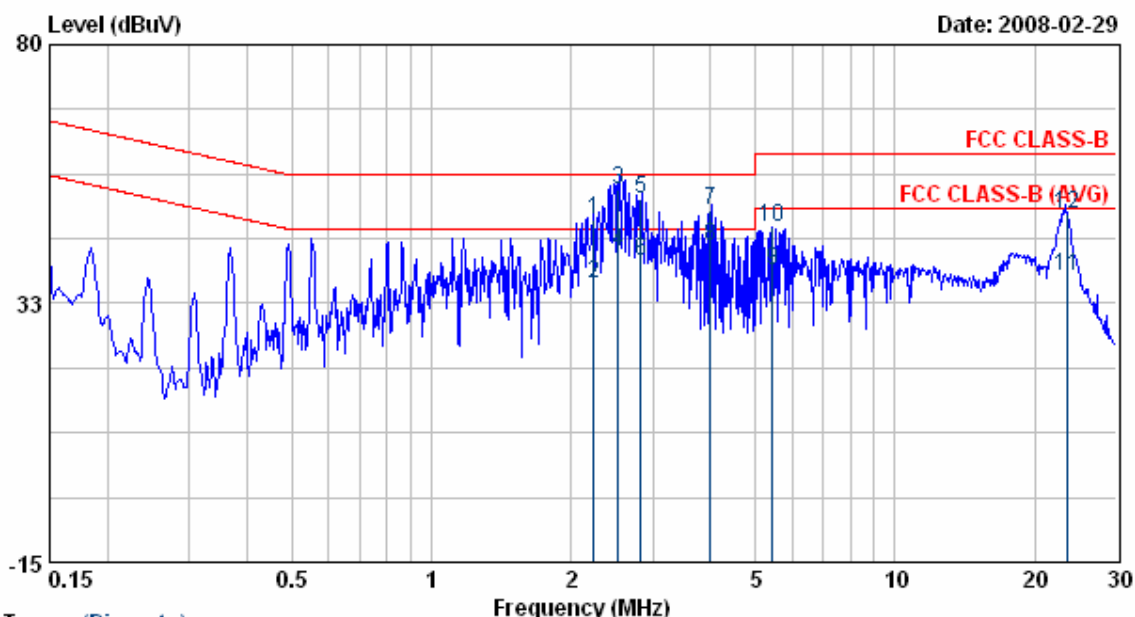

Trace: (Discrete)

Item	Freq	Read Value	Factor	Result	Limit	Margin	Remark
	MHz	dBuV	dB	dBuV	dBuV	dBuV	
1	2.24	47.60	0.20	47.81	56.00	-8.19	QP
2	2.24	35.92	0.20	36.12	46.00	-9.88	AVERAGE
3	2.53	53.05	0.21	53.26	56.00	-2.74	QP
4	2.53	41.65	0.21	41.86	46.00	-4.14	AVERAGE
5	2.83	51.36	0.22	51.58	56.00	-4.42	QP
6	2.83	40.23	0.22	40.44	46.00	-5.56	AVERAGE
7	4.00	49.38	0.23	49.61	56.00	-6.39	QP
8	4.00	42.66	0.23	42.89	46.00	-3.11	AVERAGE
9	5.45	38.37	0.27	38.64	50.00	-11.36	Average
10	5.45	46.37	0.27	46.63	60.00	-13.37	QP
11	23.42	37.08	0.48	37.56	50.00	-12.44	AVERAGE
12	23.42	48.41	0.48	48.89	60.00	-11.11	QP

- Remarks:
1. Level = Read Level + Factor
 2. Factor = LISN(ISN) Factor + Cable Loss
 3. According to technical experiences, all spurious emission of 802.11a mode at channel 36,44,48 are almost the same below 1GHz, so that the channel 36 was chosen as representative in final test.
 4. The data is worse case.

Power	: AC 120V	Pol/Phase	: NEUTRAL
Test Mode	: 802.11a CH36	Temperature	: 24 °C
Memo	: LE-9702B-01	Humidity	: 58 %

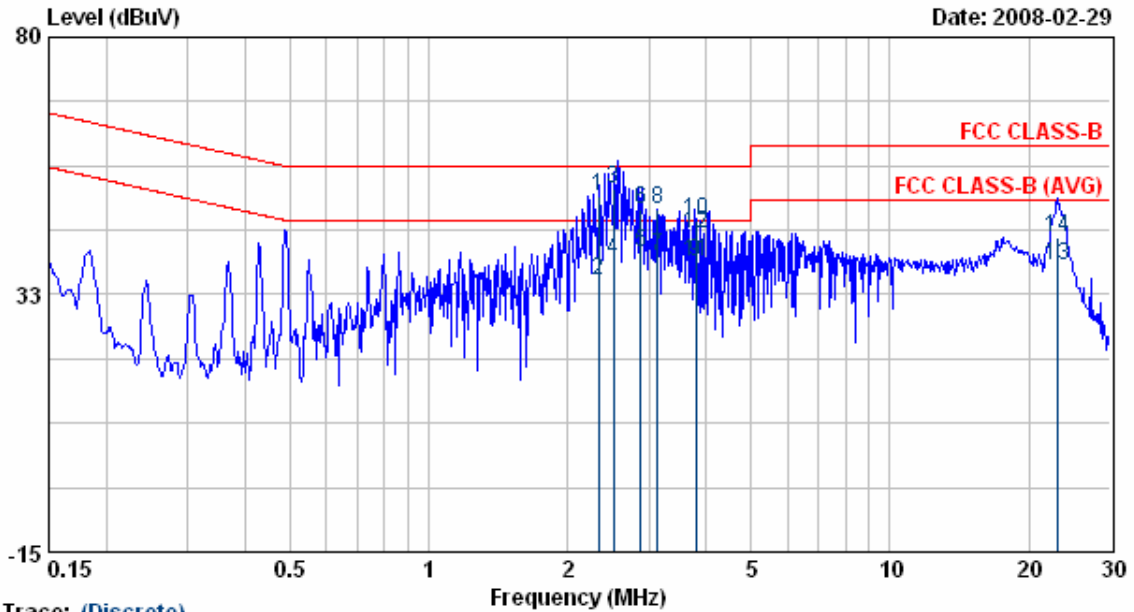

Trace: (Discrete)

Item	Freq	Read Value	Factor	Result	Limit	Margin	Remark
	MHz	dBuV	dB	dBuV	dBuV	dBuV	
1	2.33	50.27	0.20	50.47	56.00	-5.53	QP
2	2.33	34.85	0.20	35.05	46.00	-10.95	AVERAGE
3	2.52	51.83	0.21	52.04	56.00	-3.96	QP
4	2.52	38.83	0.21	39.04	46.00	-6.96	AVERAGE
5	2.88	40.15	0.22	40.37	46.00	-5.63	AVERAGE
6	2.88	48.06	0.22	48.28	56.00	-7.72	QP
7	3.14	39.48	0.23	39.71	46.00	-6.29	Average
8	3.14	48.08	0.23	48.31	56.00	-7.69	QP
9	3.80	38.36	0.25	38.60	46.00	-7.40	AVERAGE
10	3.80	45.81	0.25	46.05	56.00	-9.95	QP
11	3.80	38.45	0.25	38.70	46.00	-7.30	AVERAGE
12	3.80	43.38	0.25	43.62	56.00	-12.38	QP
13	23.09	37.10	0.65	37.76	50.00	-12.24	AVERAGE
14	23.09	42.46	0.65	43.11	60.00	-16.89	QP

- Remarks:
1. Level = Read Level + Factor
 2. Factor = LISN(ISN) Factor + Cable Loss
 3. According to technical experiences, all spurious emission of 802.11a mode at channel 36, 44, 48 are almost the same below 1GHz, so that the channel 36 was chosen as representative in final test.
 4. The data is worse case.

Test engineer: Ben

5. Test of Radiated Emission

Radiated emissions from 30 MHz to 40 GHz were measured according to the methods defines in ANSI C63.4-2003. The EUT was placed, 0.8 meter above the ground plane, as shown in section 1.4.2. The interface cables and equipment positions were varied within limits of reasonable applications to determine the positions producing maximum radiated emissions

5.1. Test Procedures

- a. The EUT was placed on a rotatable table top 0.8 meter above ground.
- b. The EUT was set 3 meters from the interference receiving antenna which was mounted on the top of a variable height antenna tower.
- c. The table was rotated 360 degrees to determine the position of the highest radiation.
- d. The antenna is a broadband antenna and its height is varied between one meter and four meters above ground to find the maximum value of the field strength both horizontal polarization and vertical polarization of the antenna are set to make the measurement.
- e. For each suspected emission the EUT was arranged to its worst case and then tune the antenna tower (from 1 M to 4 M) and turn table (from 0 degree to 360 degrees) to find the maximum reading.
- f. Set the test-receiver system to Peak or CISPR quasi-peak Detect Function and specified bandwidth with Maximum Hold Mode.
- g. If the emission level of the EUT in peak mode was 3 dB lower than the limit specified, then testing will be stopped and peak values of EUT will be reported, otherwise, the emissions which do not have 3 dB margin will be repeated one by one using the quasi-peak method and reported.
- h. For testing above 1GHz, the emission level of the EUT in peak mode was 20dB lower than average limit (that means the emission level in peak mode also complies with the limit in average mode), then testing will be stopped and peak values of EUT will be reported, otherwise, the emissions will be measured in average mode again and reported.

5.2. Typical Test Setup Layout of Radiated Emission

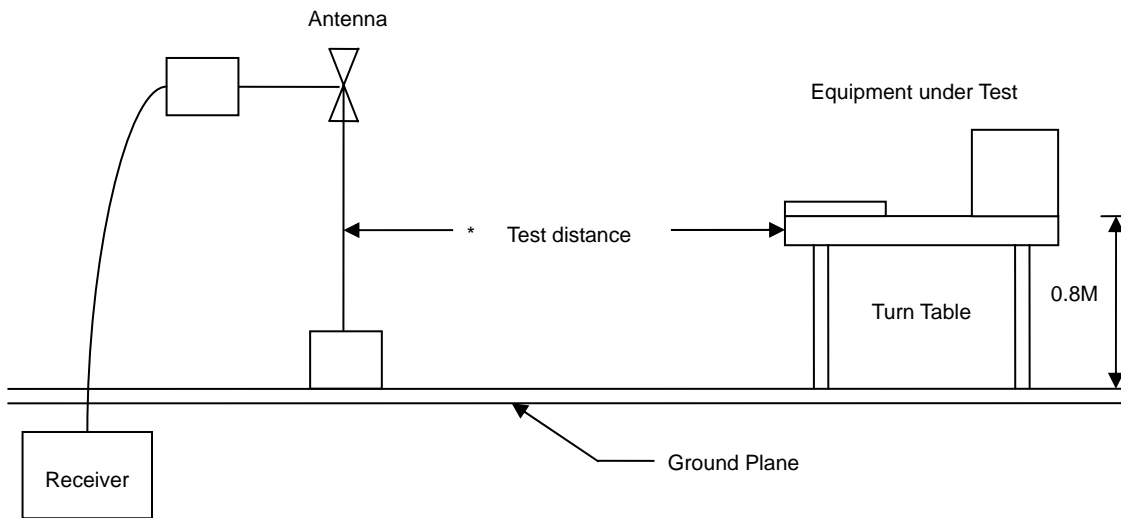

5.3. Measurement equipment

Instrument/Ancillary	Model No.	Manufacturer	Serial No.	Calibration Date	Valid Date
EMI Receiver	85460A	HP	3807A00454	2007/06/05	2008/06/04
Spectrum Analyzer	FSP40	R&S	10047	2008/02/22	2009/02/21
Horn Antenna	3115	EMCO	31601	2007/04/09	2008/04/08
Horn Antenna	3116	EMCO	31974	2007/04/04	2008/04/03
Bilog Antenna	CBL6112B	Schaffner	2840	2007/04/26	2008/04/25
Amplifier	8449B	Agilent	3008A01954	2008/01/24	2009/01/23
Amplifier	8447D	Agilent	2944A10531	2007/09/26	2008/09/25
Amplifier	PA-840	Com-Power	711885	2007/08/28	2008/08/27

5.4. Test Result and Data

Power	: AC 120V	Pol/Phase	: VERTICAL
Test Mode	: Transmit / Receive	Temperature	: 15 °C
Operation Channel	: 36	Humidity	: 70 %
Modulation Type	: 802.11a	Atmospheric Pressure	: 1030 hPa
Memo	: LE-9702B-01	Rate	: 54 Mbps

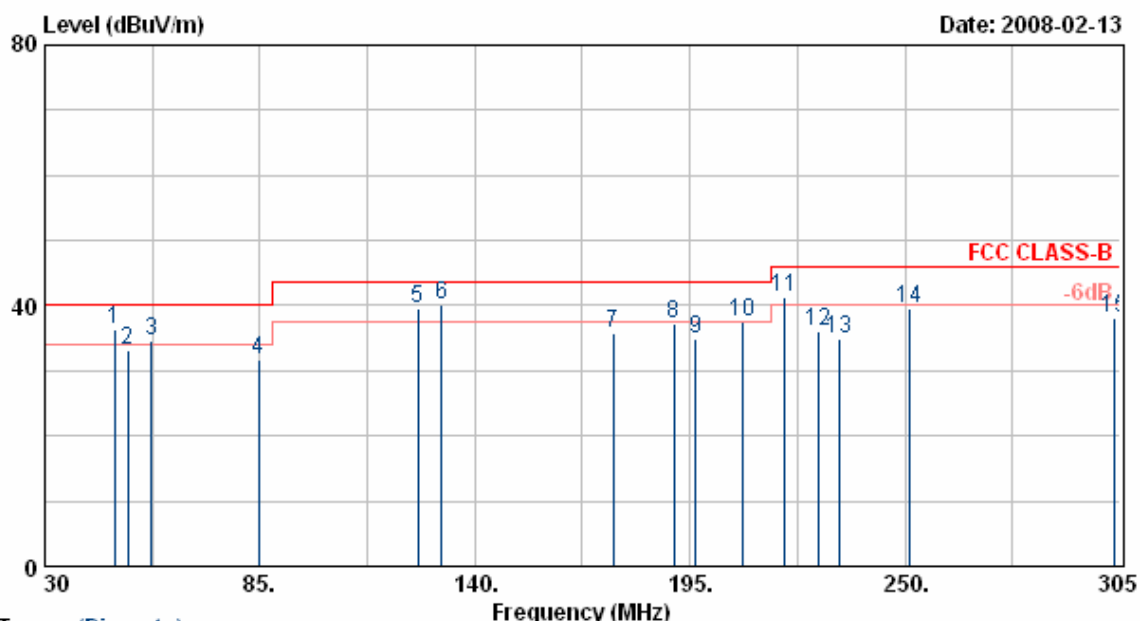

Trace: (Discrete)

Item	Freq MHz	Read Value dBuV/m	Factor dB	Result dBuV/m	Limit dBuV/m	Margin dB	Remark	Ant Pos cm	Tab Pos Deg
1	47.80	55.40	-19.01	36.39	40.00	-3.61	QP	100	96
2	51.20	53.66	-20.62	33.04	40.00	-6.96	Peak	100	122
3	57.25	52.66	-18.04	34.62	40.00	-5.38	QP	100	122
4	84.66	49.70	-17.96	31.74	40.00	-8.26	Peak	100	122
5	125.43	51.14	-11.45	39.69	43.50	-3.81	QP	100	88
6	131.50	53.24	-13.04	40.20	43.50	-3.30	QP	100	88
7	175.30	50.66	-15.01	35.65	43.50	-7.85	Peak	100	154
8	191.00	49.63	-12.49	37.14	43.50	-6.36	Peak	100	154
9	196.53	47.80	-12.95	34.85	43.50	-8.65	Peak	100	96
10	208.25	50.19	-12.73	37.47	43.50	-6.04	Peak	100	133
11	219.16	54.49	-13.28	41.21	46.00	-4.79	QP	100	133
12	227.90	49.79	-13.79	36.01	46.00	-9.99	Peak	100	222
13	233.20	47.13	-12.29	34.84	46.00	-11.16	Peak	100	222
14	251.00	50.33	-10.89	39.44	46.00	-6.56	Peak	100	222
15	303.35	50.70	-12.54	38.16	46.00	-7.84	Peak	100	50

Notes:

1. Result = Read Value + Factor
2. Factor = Antenna Factor + Cable Loss - Amplifier
3. The resolution bandwidth of test receiver/spectrum analyzer is 120KHz and video bandwidth is 300kHz for Peak detection and Quasi-peak detection at frequency below 1GHz.
4. According to technical experiences, all spurious emission of 802.11a mode at channel 36,44,48 are almost the same below 1GHz, so that the channel 36 was chosen as representative in final test.
5. The data is worse case.

Power	: AC 120V	Pol/Phase	: VERTICAL
Test Mode	: Transmit / Receive	Temperature	: 15 °C
Operation Channel	: 36	Humidity	: 70 %
Modulation Type	: 802.11a	Atmospheric Pressure	: 1030 hPa
Memo	: LE-9702B-01	Rate	: 54 Mbps

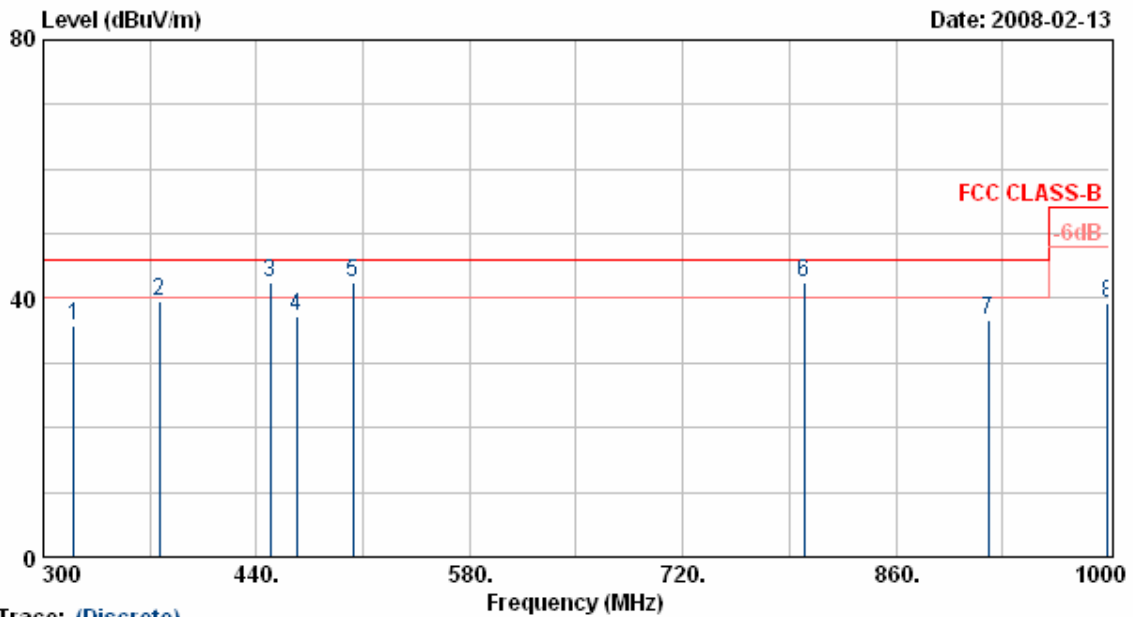

Trace: (Discrete)

Item	Freq	Read Value	Factor	Result	Limit	Margin	Remark	Ant Pos	Tab Pos
	MHz	dBuV/m	dB	dBuV/m	dBuV/m	dB		cm	Deg
1	320.30	48.63	-12.88	35.75	46.00	-10.25	Peak	100	222
2	376.30	49.22	-9.67	39.55	46.00	-6.45	Peak	100	222
3	448.80	52.13	-9.78	42.35	46.00	-3.65	QP	100	188
4	466.10	43.55	-6.19	37.36	46.00	-8.64	Peak	100	174
5	503.70	46.63	-4.26	42.37	46.00	-3.63	QP	100	180
6	799.80	44.42	-1.93	42.49	46.00	-3.51	QP	100	0
7	920.45	33.49	3.26	36.75	46.00	-9.25	Peak	100	0
8	999.30	37.90	1.41	39.31	54.00	-14.69	Peak	100	50

Notes:

1. Result = Read Value + Factor
2. Factor = Antenna Factor + Cable Loss - Amplifier
3. The resolution bandwidth of test receiver/spectrum analyzer is 120KHz and video bandwidth is 300kHz for Peak detection and Quasi-peak detection at frequency below 1GHz.
4. According to technical experiences, all spurious emission of 802.11a mode at channel 36,44,48 are almost the same below 1GHz, so that the channel 36 was chosen as representative in final test.
5. The data is worse case.

Power	: AC 120V	Pol/Phase	: HORIZONTAL
Test Mode	: Transmit / Receive	Temperature	: 15 °C
Operation Channel	: 36	Humidity	: 70 %
Modulation Type	: 802.11a	Atmospheric Pressure	: 1030 hPa
Memo	: LE-9702B-01	Rate	: 54 Mbps

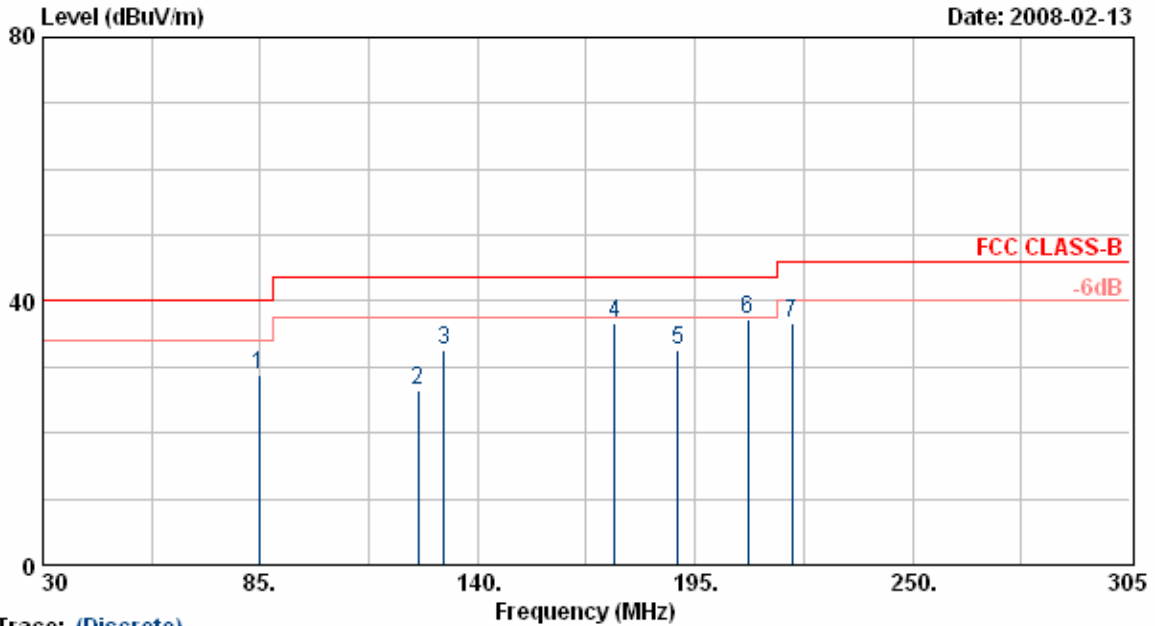

Trace: (Discrete)

Item	Freq	Read Value	Factor	Result	Limit	Margin	Remark	Ant Pos	Tab Pos
	MHz	dBuV/m	dB	dBuV/m	dBuV/m	dB		cm	Deg
1	84.76	52.50	-23.79	28.71	40.00	-11.29	Peak	200	48
2	125.00	46.55	-20.04	26.51	43.50	-16.99	Peak	200	89
3	131.46	52.53	-19.87	32.66	43.50	-10.84	Peak	200	89
4	174.69	57.54	-20.92	36.62	43.50	-6.88	Peak	200	111
5	190.78	53.44	-20.87	32.57	43.50	-10.93	Peak	200	142
6	208.48	56.20	-18.90	37.30	43.50	-6.20	Peak	200	222
7	219.48	55.28	-18.58	36.70	46.00	-9.30	Peak	200	222

Notes:

1. Result = Read Value + Factor
2. Factor = Antenna Factor + Cable Loss - Amplifier
3. The resolution bandwidth of test receiver/spectrum analyzer is 120KHz and video bandwidth is 300kHz for Peak detection and Quasi-peak detection at frequency below 1GHz.
4. According to technical experiences, all spurious emission of 802.11a mode at channel 36,44,48 are almost the same below 1GHz, so that the channel 36 was chosen as representative in final test.
5. The data is worse case.

Power	: AC 120V	Pol/Phase	: HORIZONTAL
Test Mode	: Transmit / Receive	Temperature	: 15 °C
Operation Channel	: 36	Humidity	: 70 %
Modulation Type	: 802.11a	Atmospheric Pressure	: 1030 hPa
Memo	: LE-9702B-01	Rate	: 54 Mbps

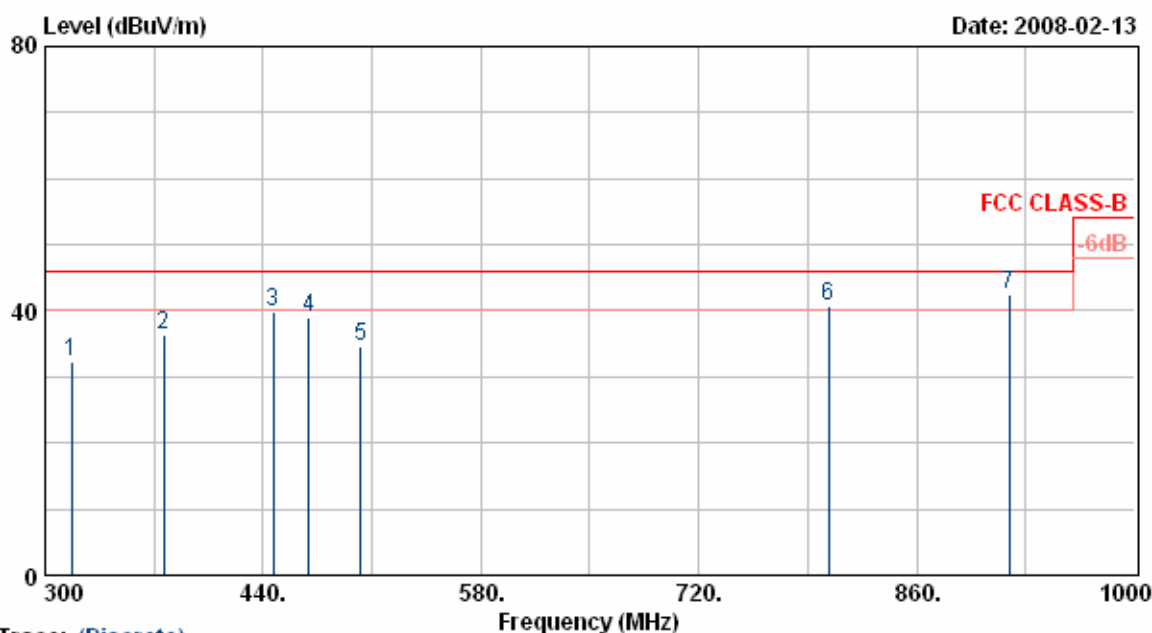

Trace: (Discrete)

Item	Freq	Read Value	Factor	Result	Limit	Margin	Remark	Ant Pos	Tab Pos
	MHz	dBuV/m	dB	dBuV/m	dBuV/m	dB		cm	Deg
1	316.80	47.36	-15.02	32.34	46.00	-13.66	Peak	200	149
2	376.30	46.70	-10.46	36.24	46.00	-9.76	Peak	200	149
3	446.30	47.39	-7.46	39.93	46.00	-6.07	Peak	200	168
4	469.40	46.50	-7.56	38.94	46.00	-7.06	Peak	200	168
5	503.00	40.99	-6.28	34.71	46.00	-11.29	Peak	200	196
6	803.30	44.25	-3.62	40.63	46.00	-5.37	QP	200	255
7	919.60	39.53	2.89	42.42	46.00	-3.58	QP	200	333

Notes:

1. Result = Read Value + Factor
2. Factor = Antenna Factor + Cable Loss - Amplifier
3. The resolution bandwidth of test receiver/spectrum analyzer is 120KHz and video bandwidth is 300kHz for Peak detection and Quasi-peak detection at frequency below 1GHz.
4. According to technical experiences, all spurious emission of 802.11a mode at channel 36,44,48 are almost the same below 1GHz, so that the channel 36 was chosen as representative in final test.
5. The data is worse case.

Power	: AC 120V	Pol/Phase	: VERTICAL
Test Mode	: Transmit / Receive	Temperature	: 15 °C
Operation Channel	: 36	Humidity	: 70 %
Modulation Type	: 802.11a	Atmospheric Pressure	: 1030 hPa
Memo	: LE-9702B-01	Rate	: 54 Mbps

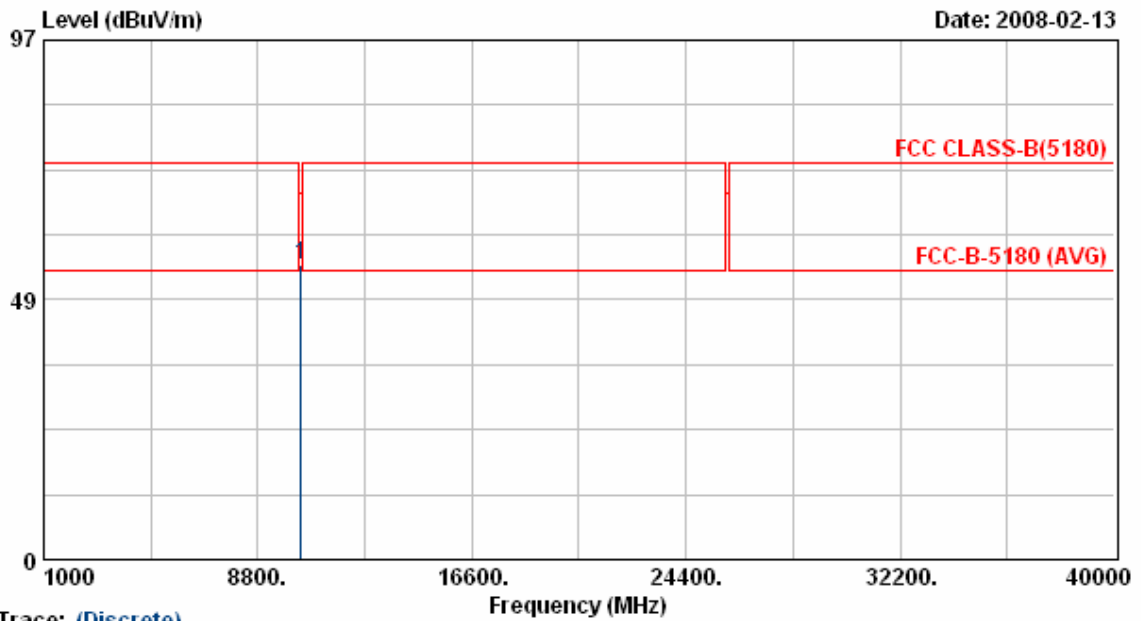

Trace: (Discrete)

Item	Freq	Read Value	Factor	Result	Limit	Margin	Remark	Ant Pos	Tab Pos
	MHz	dBuV/m	dB	dBuV/m	dBuV/m	dB		cm	Deg
1	10360.25	41.82	13.26	55.08	68.30	-13.22	Peak	100	212

Notes:

1. Result = Read Value + Factor
2. Factor = Antenna Factor + Cable Loss - Amplifier
3. The resolution bandwidth of test receiver/spectrum analyzer is 120KHz and video bandwidth is 300kHz for Peak detection and Quasi-peak detection at frequency below 1GHz.
4. The resolution bandwidth of test receiver/spectrum analyzer is 1MHz and video bandwidth is 3MHz for Peak detection at frequency above 1GHz.
5. The resolution bandwidth of test receiver/spectrum analyzer is 1MHz and video bandwidth is 10Hz for Average detection at frequency above 1GHz.
6. The other emissions is too low to be measured.

Power	: AC 120V	Pol/Phase	: HORIZONTAL
Test Mode	: Transmit / Receive	Temperature	: 15 °C
Operation Channel	: 36	Humidity	: 70 %
Modulation Type	: 802.11a	Atmospheric Pressure	: 1030 hPa
Memo	: LE-9702B-01	Rate	: 54 Mbps

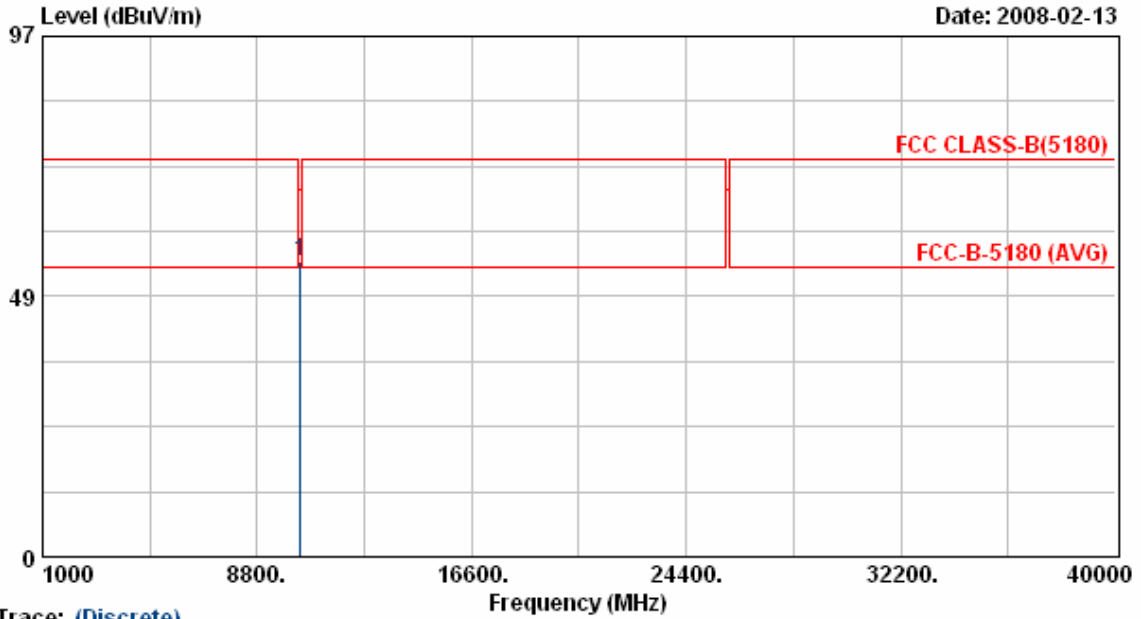

Trace: (Discrete)

Item	Freq	Read Value	Factor	Result	Limit	Margin	Remark	Ant Pos	Tab Pos
	MHz	dBuV/m	dB	dBuV/m	dBuV/m	dB		cm	Deg
1	10360.25	41.72	13.26	54.98	68.30	-13.32	Peak	100	212

Notes:

1. Result = Read Value + Factor
2. Factor = Antenna Factor + Cable Loss - Amplifier
3. The resolution bandwidth of test receiver/spectrum analyzer is 120KHz and video bandwidth is 300kHz for Peak detection and Quasi-peak detection at frequency below 1GHz.
4. The resolution bandwidth of test receiver/spectrum analyzer is 1MHz and video bandwidth is 3MHz for Peak detection at frequency above 1GHz.
5. The resolution bandwidth of test receiver/spectrum analyzer is 1MHz and video bandwidth is 10Hz for Average detection at frequency above 1GHz.
6. The other emissions is too low to be measured.

Power	: AC 120V	Pol/Phase	: VERTICAL
Test Mode	: Transmit / Receive	Temperature	: 15 °C
Operation Channel	: 44	Humidity	: 70 %
Modulation Type	: 802.11a	Atmospheric Pressure	: 1030 hPa
Memo	: LE-9702B-01	Rate	: 54 Mbps

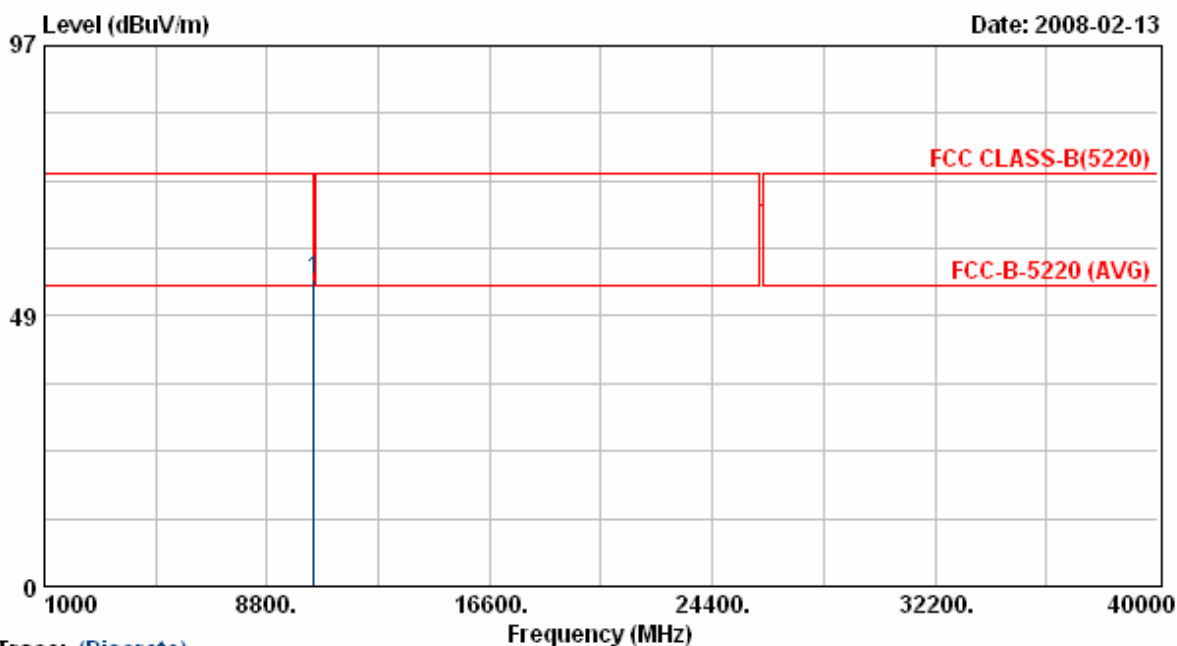

Trace: (Discrete)

Item	Freq	Read Value	Factor	Result	Limit	Margin	Remark	Ant Pos	Tab Pos
	MHz	dBuV/m	dB	dBuV/m	dBuV/m	dB		cm	Deg
1	10440.13	41.73	13.34	55.07	68.30	-13.23	Peak	100	212

Notes:

1. Result = Read Value + Factor
2. Factor = Antenna Factor + Cable Loss - Amplifier
3. The resolution bandwidth of test receiver/spectrum analyzer is 120KHz and video bandwidth is 300kHz for Peak detection and Quasi-peak detection at frequency below 1GHz.
4. The resolution bandwidth of test receiver/spectrum analyzer is 1MHz and video bandwidth is 3MHz for Peak detection at frequency above 1GHz.
5. The resolution bandwidth of test receiver/spectrum analyzer is 1MHz and video bandwidth is 10Hz for Average detection at frequency above 1GHz.
6. The other emissions is too low to be measured.

Power	: AC 120V	Pol/Phase	: HORIZONTAL
Test Mode	: Transmit / Receive	Temperature	: 15 °C
Operation Channel	: 44	Humidity	: 70 %
Modulation Type	: 802.11a	Atmospheric Pressure	: 1030 hPa
Memo	: LE-9702B-01	Rate	: 54 Mbps

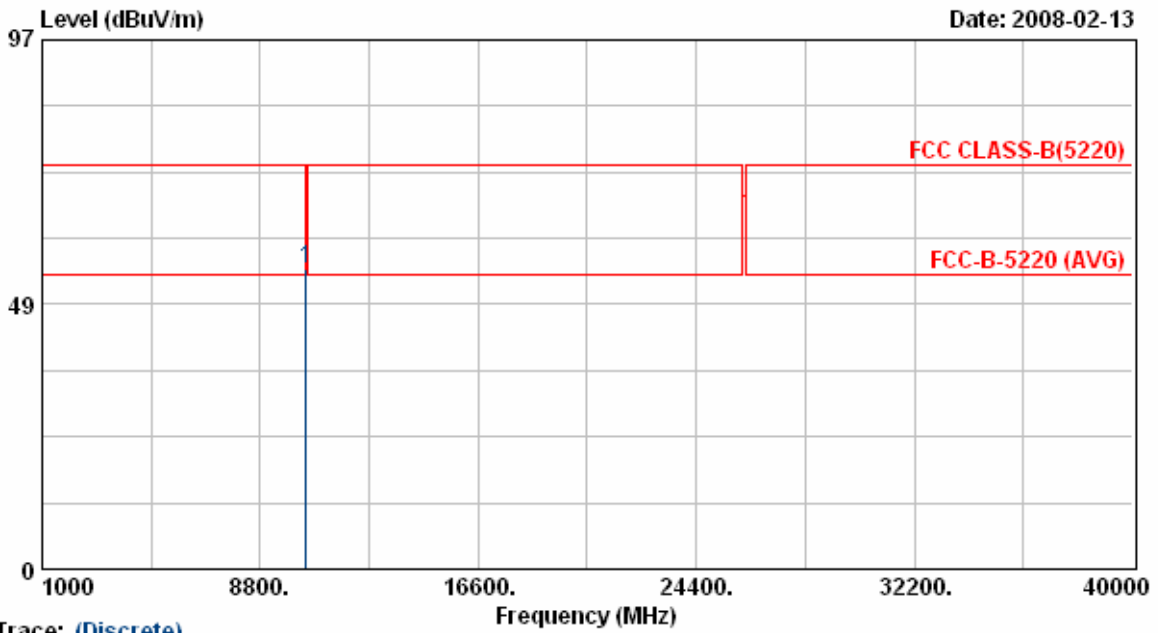

Item	Freq	Read Value	Factor	Result	Limit	Margin	Remark	Ant Pos	Tab Pos
	MHz	dBuV/m	dB	dBuV/m	dBuV/m	dB		cm	Deg
1	10440.13	41.58	13.34	54.92	68.30	-13.38	Peak	100	212

Notes:

1. Result = Read Value + Factor
2. Factor = Antenna Factor + Cable Loss - Amplifier
3. The resolution bandwidth of test receiver/spectrum analyzer is 120KHz and video bandwidth is 300kHz for Peak detection and Quasi-peak detection at frequency below 1GHz.
4. The resolution bandwidth of test receiver/spectrum analyzer is 1MHz and video bandwidth is 3MHz for Peak detection at frequency above 1GHz.
5. The resolution bandwidth of test receiver/spectrum analyzer is 1MHz and video bandwidth is 10Hz for Average detection at frequency above 1GHz.
6. The other emissions is too low to be measured.

Power	: AC 120V	Pol/Phase	: VERTICAL
Test Mode	: Transmit / Receive	Temperature	: 15 °C
Operation Channel	: 48	Humidity	: 70 %
Modulation Type	: 802.11a	Atmospheric Pressure	: 1030 hPa
Memo	: LE-9702B-01	Rate	: 54 Mbps

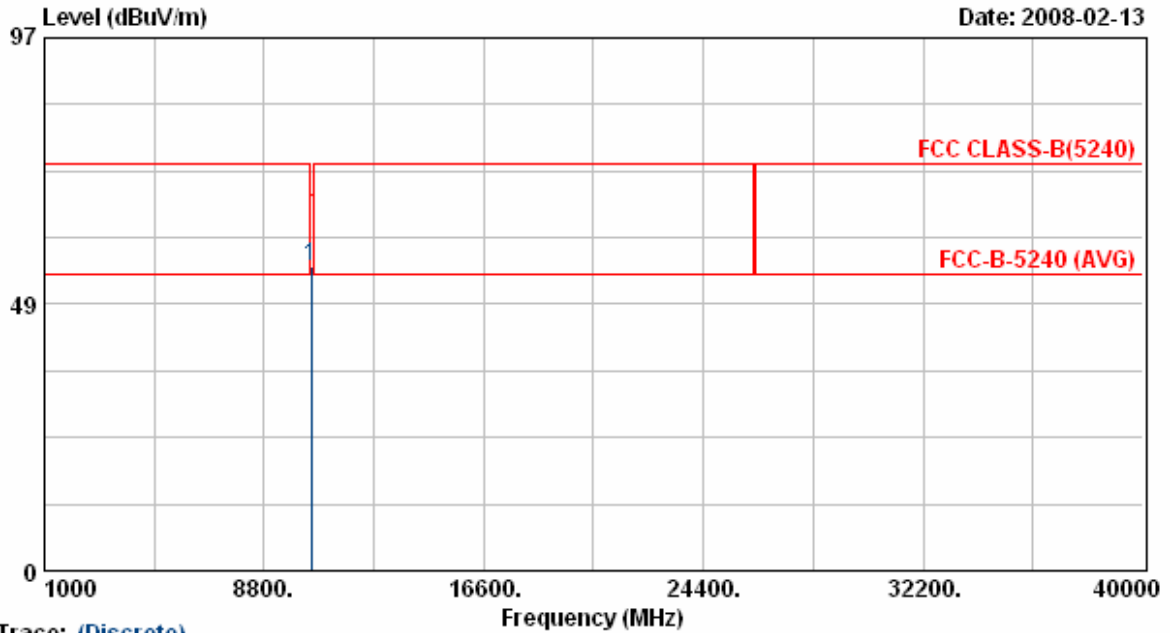

Trace: (Discrete)

Item	Freq	Read Value	Factor	Result	Limit	Margin	Remark	Ant Pos	Tab Pos
	MHz	dBuV/m	dB	dBuV/m	dBuV/m	dB		cm	Deg
1	10480.13	41.99	13.38	55.37	68.30	-12.93	Peak	100	212

Notes:

1. Result = Read Value + Factor
2. Factor = Antenna Factor + Cable Loss - Amplifier
3. The resolution bandwidth of test receiver/spectrum analyzer is 120KHz and video bandwidth is 300kHz for Peak detection and Quasi-peak detection at frequency below 1GHz.
4. The resolution bandwidth of test receiver/spectrum analyzer is 1MHz and video bandwidth is 3MHz for Peak detection at frequency above 1GHz.
5. The resolution bandwidth of test receiver/spectrum analyzer is 1MHz and video bandwidth is 10Hz for Average detection at frequency above 1GHz.
6. The other emissions is too low to be measured.

Power	: AC 120V	Pol/Phase	: HORIZONTAL
Test Mode	: Transmit / Receive	Temperature	: 15 °C
Operation Channel	: 48	Humidity	: 70 %
Modulation Type	: 802.11a	Atmospheric Pressure	: 1030 hPa
Memo	: LE-9702B-01	Rate	: 54 Mbps

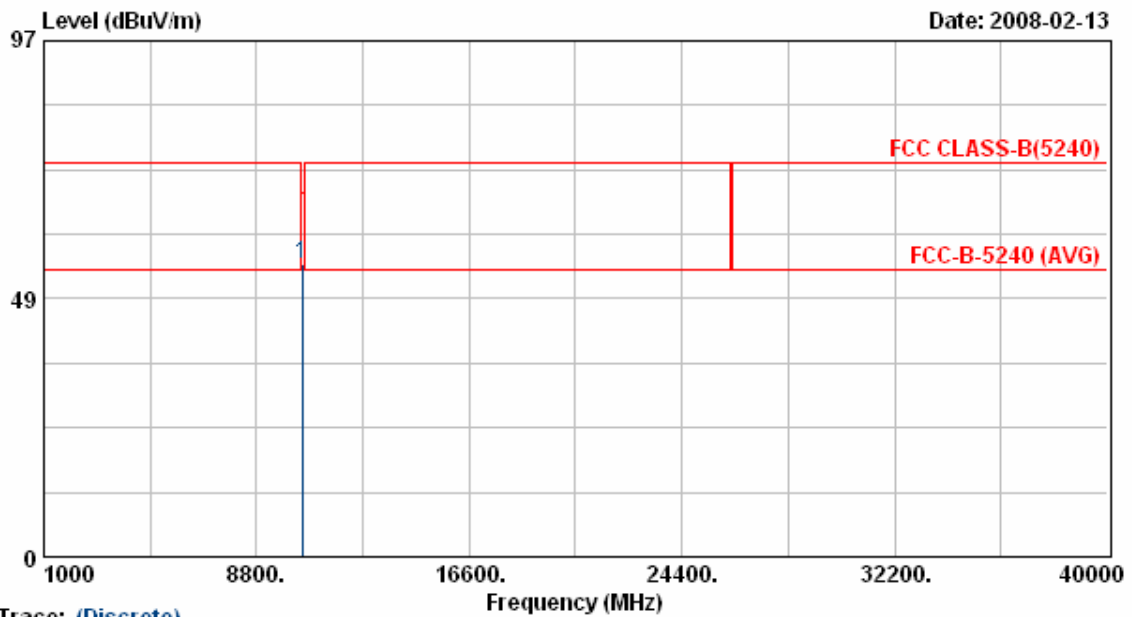

Trace: (Discrete)

Item	Freq	Read Value	Factor	Result	Limit	Margin	Remark	Ant Pos	Tab Pos
	MHz	dBuV/m	dB	dBuV/m	dBuV/m	dB		cm	Deg
1	10480.13	41.69	13.38	55.07	68.30	-13.23	Peak	100	212

Notes:

1. Result = Read Value + Factor
2. Factor = Antenna Factor + Cable Loss - Amplifier
3. The resolution bandwidth of test receiver/spectrum analyzer is 120KHz and video bandwidth is 300kHz for Peak detection and Quasi-peak detection at frequency below 1GHz.
4. The resolution bandwidth of test receiver/spectrum analyzer is 1MHz and video bandwidth is 3MHz for Peak detection at frequency above 1GHz.
5. The resolution bandwidth of test receiver/spectrum analyzer is 1MHz and video bandwidth is 10Hz for Average detection at frequency above 1GHz.
6. The other emissions is too low to be measured.

6. Peak Transmit Power

6.1. Test Procedure

The antenna port (RF output) of the EUT was connected to the input (RF input) of a spectrum analyzer. Power was read directly from the spectrum analyzer and cable loss connection was added to the reading to obtain power at the EUT antenna terminal. The EUT Output Power was set to maximum to produce the worse case test result.

6.2. Test Setup Layout

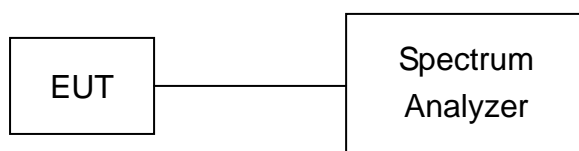

6.3. Measurement equipment

Instrument/Ancillary	Model No.	Manufacturer	Serial No.	Calibration Date	Valid Date.
Spectrum Analyzer	FSP40	R&S	100047	2008/02/22	2009/02/21

6.4. Test Result and Data

(1) Modulation Standard: IEEE 802.11a (54Mbps)

Test Date: Jan. 28, 2008 Temperature: 20 Humidity: 60% Atmospheric pressure: 1008 hPa

Channel	Frequency (MHz)	Peak Power Output (dBm)	Peak Power Output (mW)	26dB Occupied Bandwidth (MHz)
36	5180	13.21	20.90	20.40
44	5220	12.96	19.80	20.30
48	5240	13.01	20.00	20.20

Peak Transmit Power

Modulation Standard: 802.11a (54Mbps)

Channel: 36

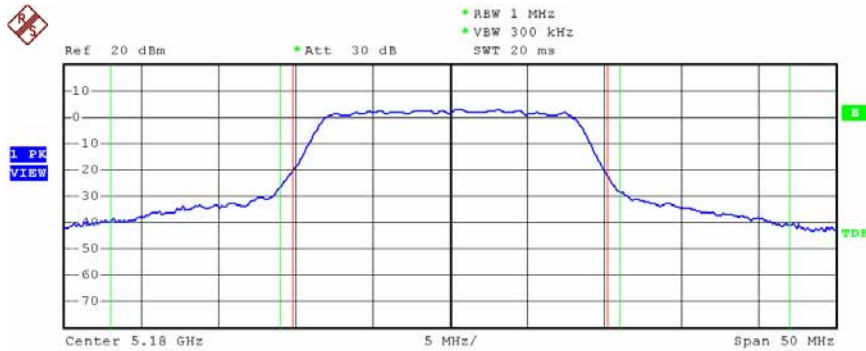

Tx Channel			
Bandwidth	20.4 MHz	Power	13.21 dBm
Adjacent Channel			
Bandwidth	11 MHz	Lower	-37.24 dB
Spacing	16.5 MHz	Upper	-37.89 dB
Alternate Channel			
Bandwidth	11 MHz	Lower	-----
Spacing	27.5 MHz	Upper	-----

Date: 28.JAN.2008 17:33:48

Modulation Standard: 802.11a (54Mbps)

Channel: 44

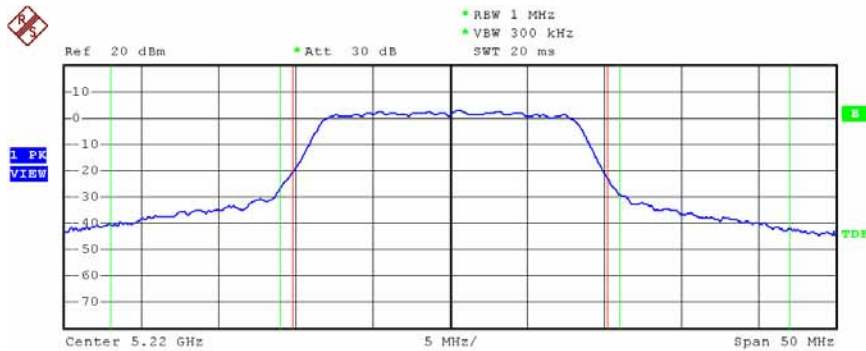

Tx Channel			
Bandwidth	20.3 MHz	Power	12.96 dBm
Adjacent Channel			
Bandwidth	11 MHz	Lower	-37.84 dB
Spacing	16.5 MHz	Upper	-38.99 dB
Alternate Channel			
Bandwidth	11 MHz	Lower	-----
Spacing	27.5 MHz	Upper	-----

Date: 28.JAN.2008 17:36:27

Modulation Standard: 802.11a (54Mbps)
 Channel: 48

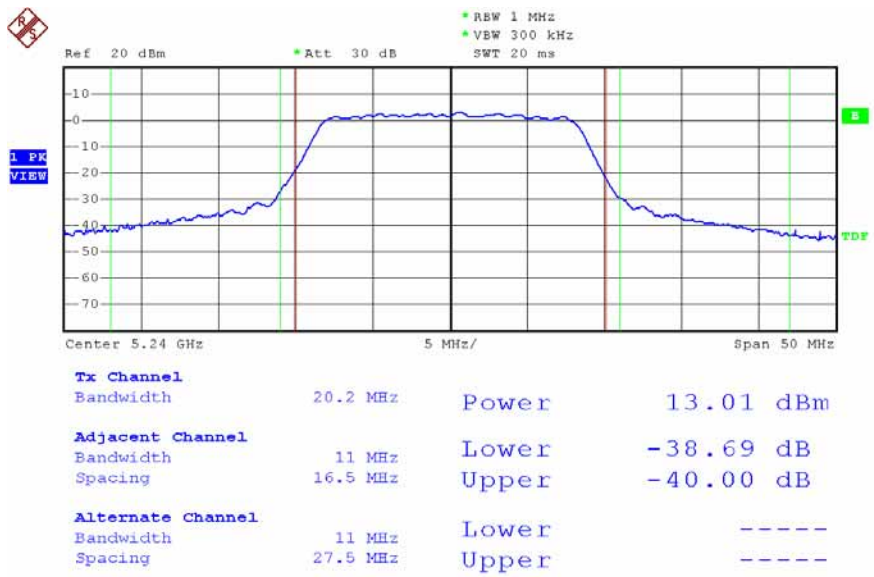

Date: 28.JAN.2008 17:38:08

26dB Occupied Bandwidth (MHz)

Modulation Standard: 802.11a (54Mbps)

Channel: 36

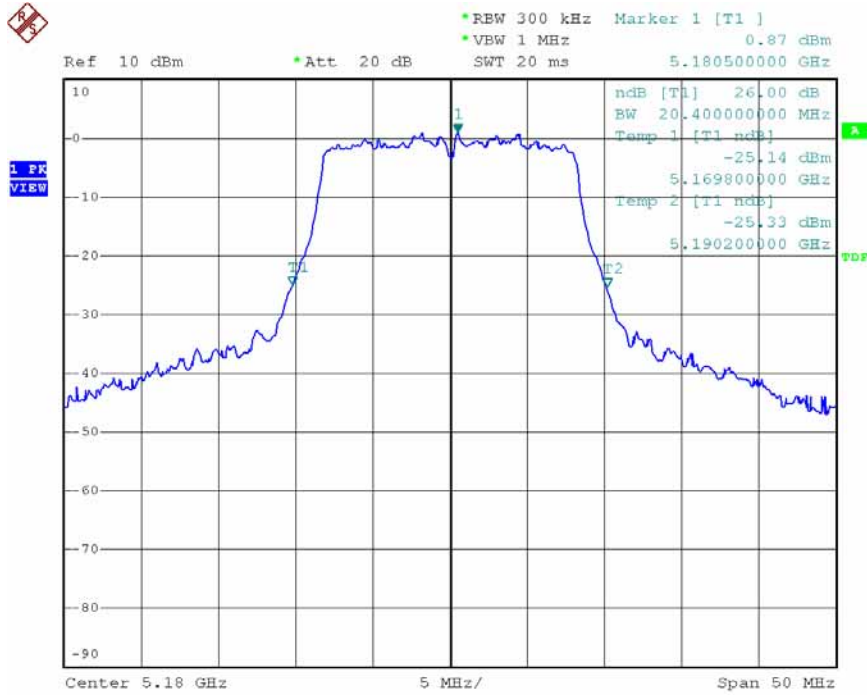

Date: 28.JAN.2008 17:33:07

Modulation Standard: 802.11a (54Mbps)

Channel: 44

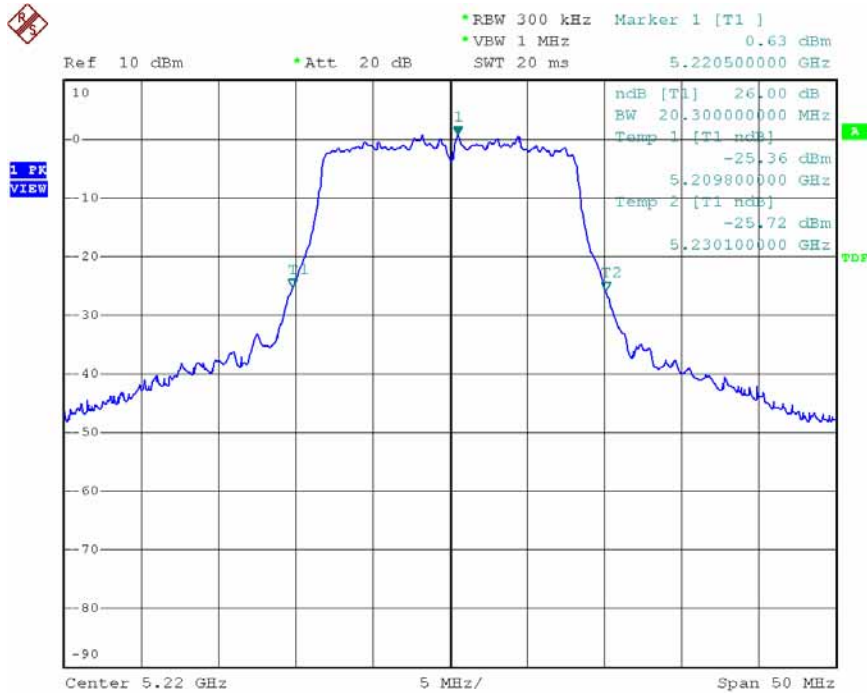

Date: 28.JAN.2008 17:34:38

Modulation Standard: 802.11a (54Mbps)
 Channel: 48

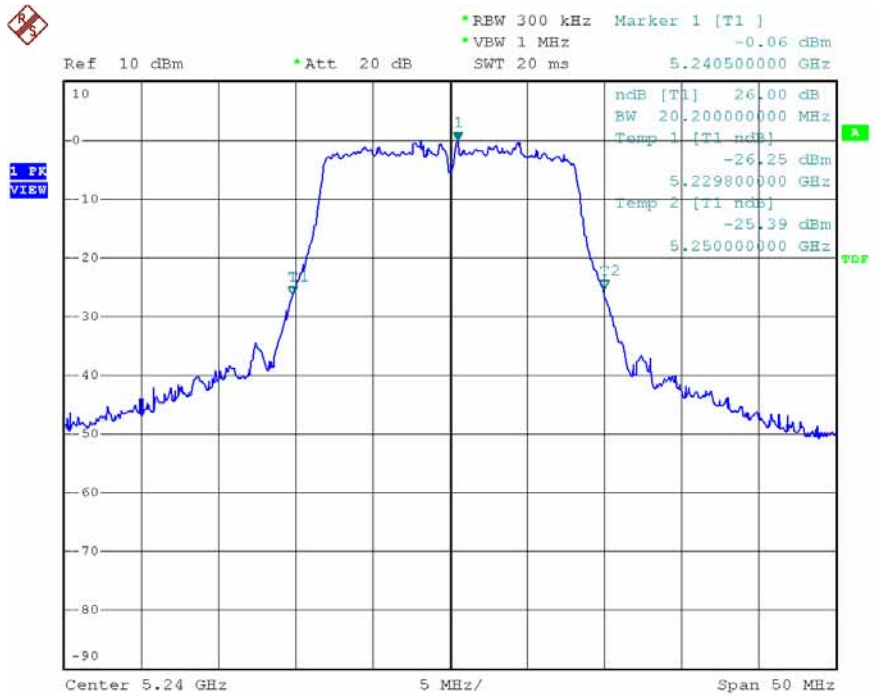

Date: 28.JAN.2008 17:37:12

7. Peak Power Excursion

7.1. Test Procedure

- a. The transmitter output was connected to the spectrum analyzer
- b. Using Peak detector and max-hold function for Trace 1 MHz and VBW to 3 MHz for Trace 1.
- c. Set RBW of spectrum analyzer to 1 MHz and VBW to 3 MHz for Trace 1.
- d. Set RBW of spectrum analyzer to 1 MHz and VBW to 300 kHz for Trace 2.
- e. The largest difference between Trace 1 and Trace 2 in any 1 MHz band on any frequency was recorded.

7.2. Test Setup Layout

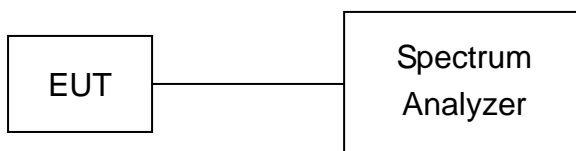

7.3. Measurement equipment

Instrument/Ancillary	Model No.	Manufacturer	Serial No.	Calibration Date	Valid Date.
Spectrum Analyzer	FSP40	R&S	100047	2007/01/23	2008/01/22

7.4. Test Result and Data

- (1) Modulation Standard: IEEE 802.11a (54Mbps)

Test Date: Jan. 28, 2008 Temperature: 20 Humidity: 60% Atmospheric pressure: 1008 hPa

Channel	Frequency (MHz)	Peak Power Excursion (dB)
36	5180	11.22
44	5220	11.30
48	5240	11.07

Modulation Standard: 802.11a (54Mbps)
 Channel: 36

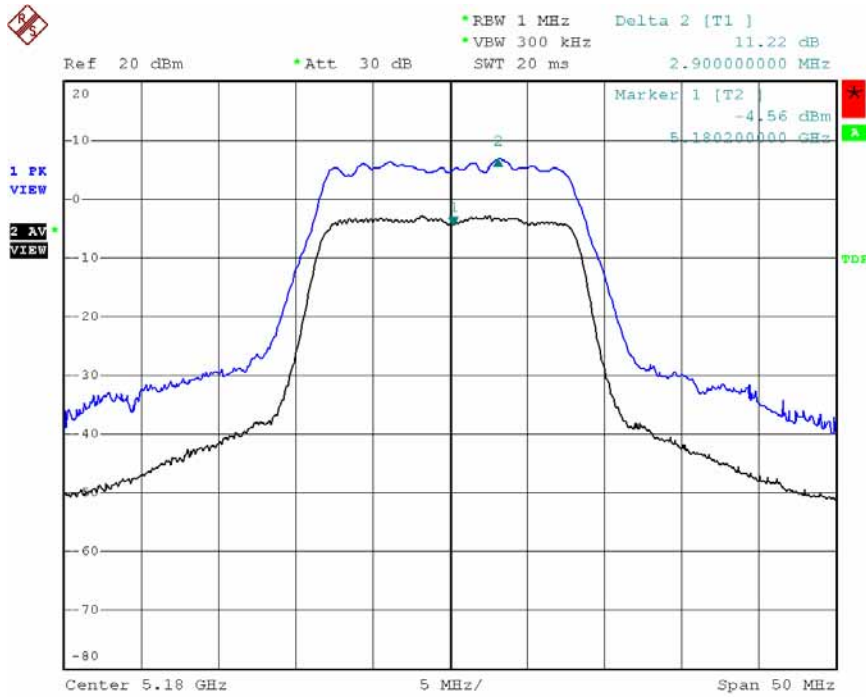

Date: 28.JAN.2008 18:04:52

Modulation Standard: 802.11a (54Mbps)
 Channel: 44

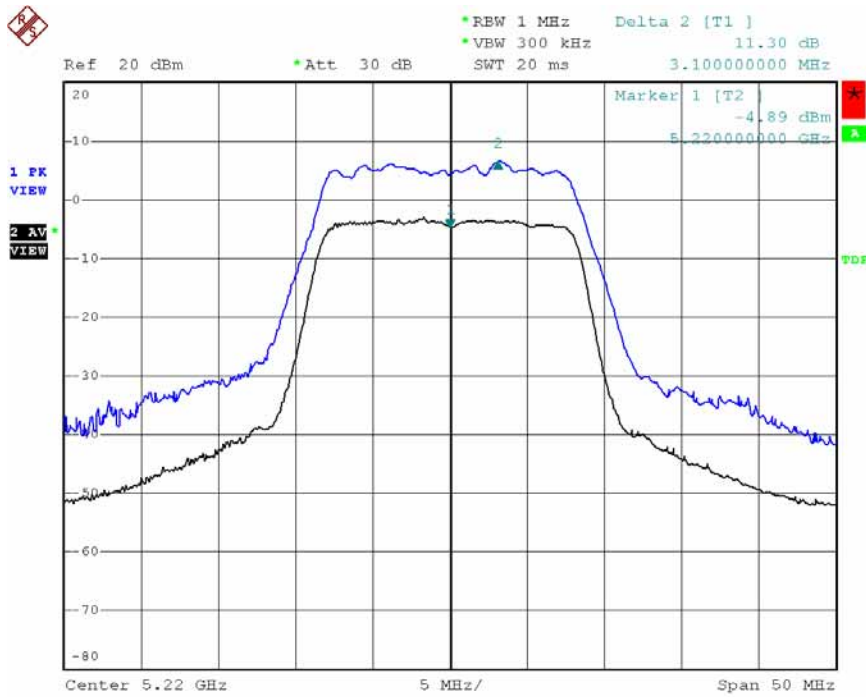

Date: 28.JAN.2008 18:03:37

Modulation Standard: 802.11a (54Mbps)
Channel: 48

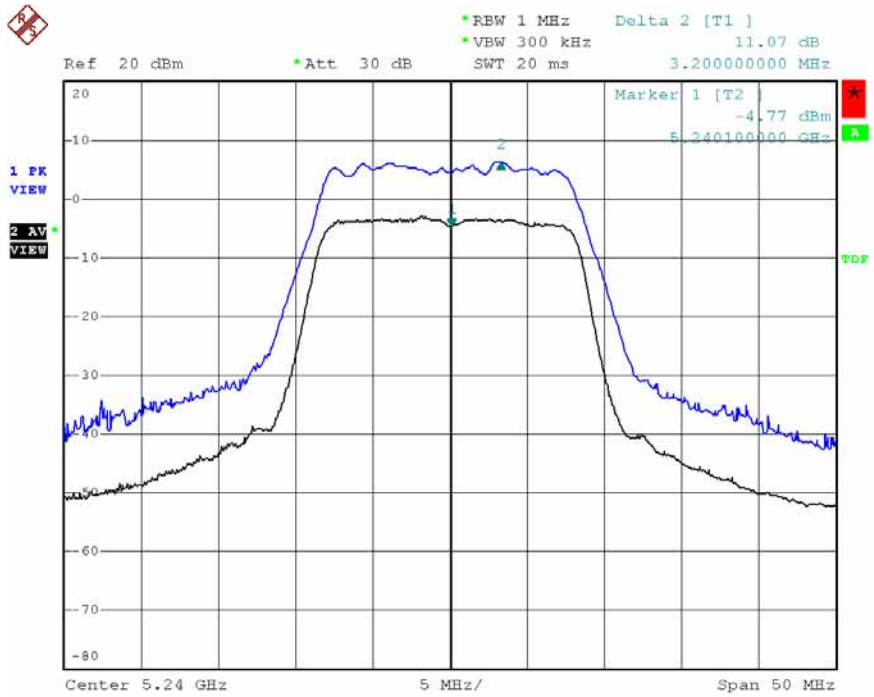

Date: 28.JAN.2008 18:02:11

8. Peak Power Spectral Density

8.1. Test Procedure

- a. The transmitter output was connected to spectrum analyzer.
- b. Set RBW of spectrum analyzer to 1 MHz and VBW to 3 MHz
- c. The Peak Power Spectral Density is the highest level found across the emission in any 1MHz Band

8.2. Test Setup Layout

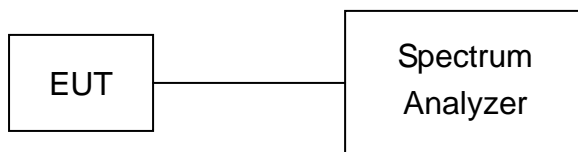

8.3. Measurement equipment

Instrument/Ancillary	Model No.	Manufacturer	Serial No.	Calibration Date	Valid Date.
Spectrum Analyzer	FSP40	R&S	100047	2007/01/23	2008/01/22

8.4. Test Result and Data

- (1) Modulation Standard: IEEE 802.11a (54Mbps)

Test Date: Jan. 28, 2008 Temperature: 20 Humidity: 60% Atmospheric pressure: 1008 hPa

Channel	Frequency (MHz)	RF Power Level In 1MHz BW (dBm)
36	5180	-4.49
44	5220	-5.01
48	5240	-4.76

Modulation Standard: 802.11a (54Mbps)
 Channel: 36

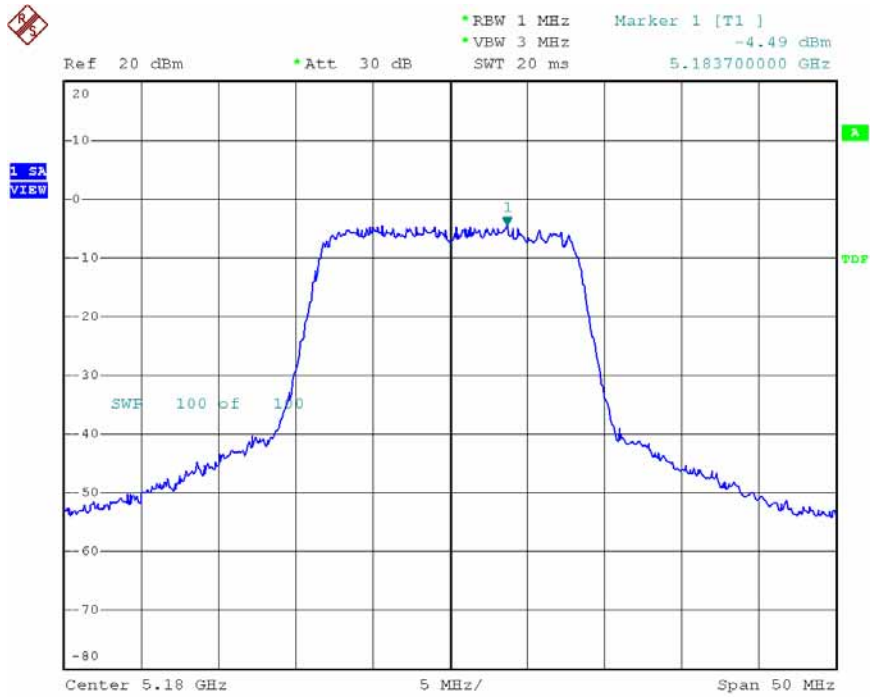

Date: 28.JAN.2008 18:05:48

Modulation Standard: 802.11a (54Mbps)
 Channel: 44

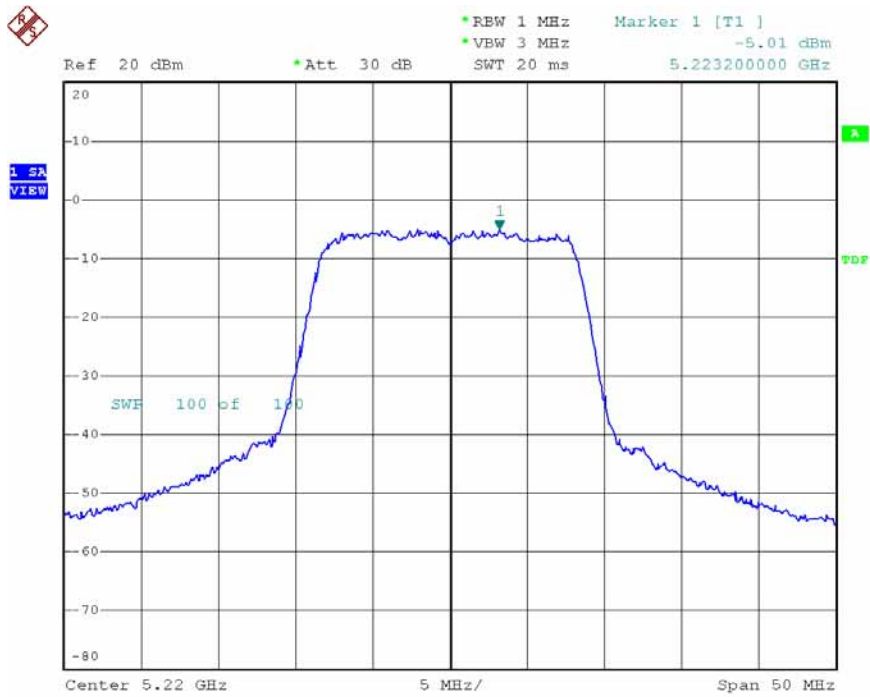

Date: 28.JAN.2008 18:06:50

Modulation Standard: 802.11a (54Mbps)
Channel: 48

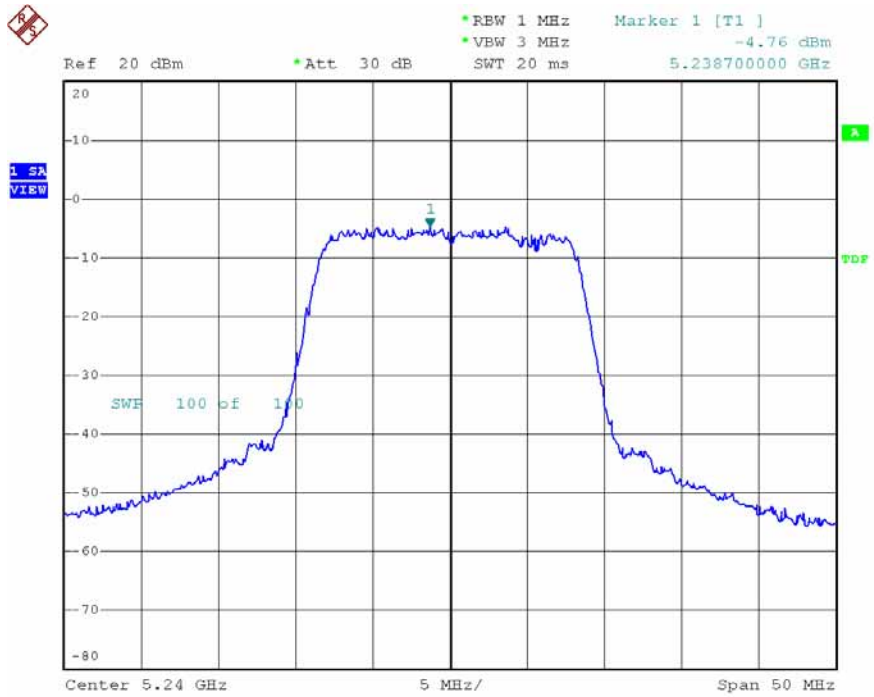

Date: 28.JAN.2008 18:07:19

9. Frequency Stability

9.1. Test Procedure

1. The EUT was placed inside the Temperature and Humidity chamber.
2. The transmitter output was connected to spectrum analyzer.
3. Turn the EUT on and couple its output to a spectrum analyzer.
4. Turn the EUT off and set the chamber to the highest temperature specified.
5. Allow sufficient time (approximately 30 min) for the temperature of the chamber to stabilize, turn the EUT on and measure the operating frequency after 2, 5, and 10 minutes.
6. Repeat step 2 and 3 with the temperature chamber set to the lowest temperature.
7. The test chamber was allowed to stabilize at +20 degree C for a minimum of 30 minutes. The supply voltage was then adjusted on the EUT from 85% to 115% and the frequency record.

9.2. Test Setup Layout

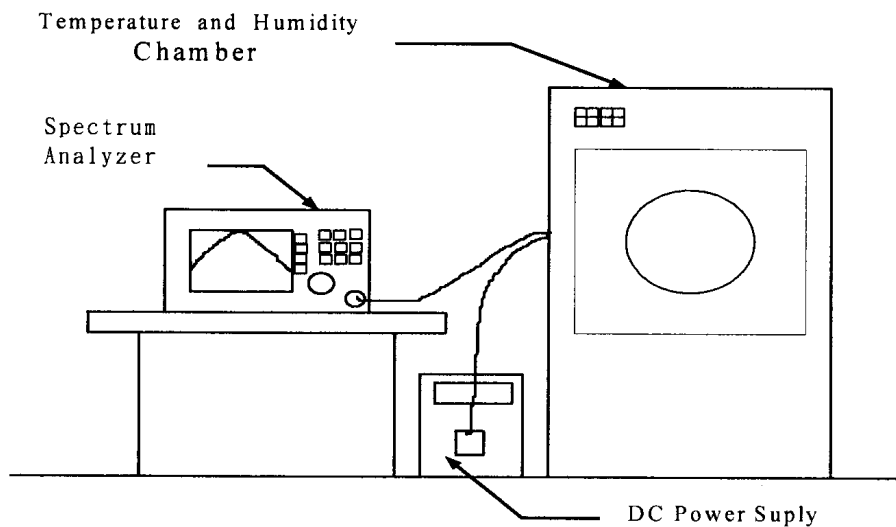

9.3. Measurement equipment

Instrument/Ancillary	Model No.	Manufacturer	Serial No.	Calibration Date	Valid Date.
Spectrum Analyzer	FSP40	R&S	100047	2008/02/22	2009/02/21
Temperature Chamber	TMJ-9712	T MACHINE	T-12-040111	2008/01/15	2009/01/14
DC Power Supply	GPD-3030	GM	7020936	N/A	N/A
AC POWER CONVERTER	AFC-11005	APC	F103120008	N/A	N/A

9.4. Test Result and Data

Operating frequency: 5240 MHz							
Temp (°C)	Power supply (V)	2 minute		5 minute		10 minute	
		(MHz)	(%)	(MHz)	(%)	(MHz)	(%)
50	102	5239.9877	-0.000235	5239.9204	-0.001519	5239.9854	-0.000279
	120	5239.9662	-0.000645	5239.9881	-0.000227	5239.9884	-0.000221
	138	5239.9895	-0.000200	5239.9654	-0.000660	5239.9515	-0.000926
40	102	5239.9866	-0.000256	5239.9811	-0.000361	5240.0223	0.000426
	120	5239.9627	-0.000712	5240.0247	0.000471	5239.9876	-0.000237
	138	5239.9891	-0.000208	5239.9813	-0.000357	5239.9815	-0.000353
30	102	5239.9738	-0.000500	5240.0012	0.000023	5239.9921	-0.000151
	120	5239.9861	-0.000265	5240.0221	0.000422	5239.9531	-0.000895
	138	5239.9882	-0.000225	5240.0817	0.001559	5239.9771	-0.000437
20	102	5240.0154	0.000294	5240.0054	0.000103	5240.0032	0.000061
	120	5240.0102	0.000195	5239.9846	-0.000294	5240.0418	0.000798
	138	5240.0055	0.000105	5240.0118	0.000225	5239.9484	-0.000985
10	102	5240.0107	0.000204	5240.0121	0.000231	5240.0132	0.000252
	120	5240.0032	0.000061	5239.9655	-0.000658	5240.0212	0.000405
	138	5240.0068	0.000130	5240.0143	0.000273	5239.9873	-0.000242
0	102	5239.9844	-0.000298	5239.9679	-0.000613	5239.9297	-0.001342
	120	5239.9762	-0.000454	5239.9766	-0.000447	5239.9794	-0.000393
	138	5239.9691	-0.000590	5239.9866	-0.000256	5239.9803	-0.000376
-10	102	5240.0185	0.000353	5239.9571	-0.000819	5240.0105	0.000200
	120	5240.0083	0.000158	5240.0178	0.000340	5240.01784	0.000340
	138	5239.9797	-0.000387	5239.9944	-0.000107	5239.9943	-0.000109
-20	102	5240.0213	0.000406	5240.0271	0.000517	5240.0112	0.000214
	120	5240.0013	0.000025	5240.019	0.000363	5240.0079	0.000151
	138	5240.0116	0.000221	5240.0107	0.000204	5240.0139	0.000265
-30	102	5240.0042	0.000080	5240.0037	0.000071	5240.0152	0.000290
	120	5240.0031	0.000059	5240.0166	0.000317	5240.0224	0.000427
	138	5240.0104	0.000198	5240.0103	0.000197	5240.0168	0.000321

Limit :

Manufacturers of U-NII devices are responsible for ensuring frequency stability such that an emission is maintained within the band of operation under all conditions of normal operation as specified in the users manual.

10. Band Edges Measurement

10.1. Test Procedure

- a. The transmitter output was connected to the spectrum analyzer via a low lose cable.
- b. Set both RBW and VBW of spectrum analyzer to 100 KHz with convenient frequency span including 100 MHz bandwidth from band edge
- c. The band edges was measured and recorded..

10.2. Measurement equipment

Instrument/Ancillary	Model No.	Manufacturer	Serial No.	Calibration Date	Valid Date
EMI Receiver	85460A	HP	3807A00454	2007/06/05	2008/06/04
Spectrum Analyzer	FSP40	R&S	10047	2008/02/22	2009/02/21
Horn Antenna	3115	EMCO	31601	2007/04/09	2008/04/08
Horn Antenna	3116	EMCO	31974	2007/04/04	2008/04/03
Bilog Antenna	CBL6112B	Schaffner	2840	2007/04/26	2008/04/25
Amplifier	8449B	Agilent	3008A01954	2008/01/24	2009/01/23
Amplifier	8447D	Agilent	2944A10531	2007/09/26	2008/09/25
Amplifier	PA-840	Com-Power	711885	2007/08/28	2008/08/27

10.3. Test Result and Data

- (1) Modulation Standard: IEEE 802.11a (6Mbps)

Test Date: Jan. 21, 2008 Temperature: 20 Humidity: 60% Atmospheric pressure: 1008 hPa

Channel	Frequency (MHz)	Maximum Value In Frequency (MHz)	Maximum Value (dBm)
36	5180	5127.80	-38.65

Modulation Standard: 802.11a (54Mbps)
Channel: 36

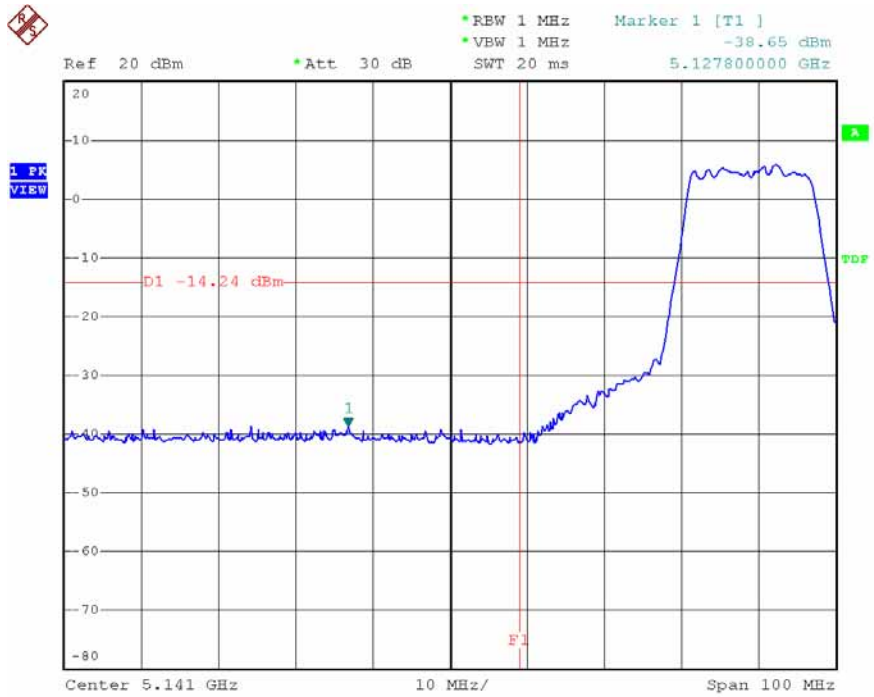

Date: 28.JAN.2008 18:17:37

10.4. Restrict Band Emission Measurement Data

Modulation Standard: 802.11a (54Mbps)

Test Date: Jan. 21, 2008 Temperature: 20 Humidity: 70% Atmospheric pressure: 1008 hPa

Channel 38, Fundamental Frequency: 5180 MHz

Frequency (MHz)	Ant-Pol H/V	Meter Reading	Corrected Factor	Result (dBuV/m)	Remark	Limit@3m (dBuV/m)		Margin (dB)	Table (Deg.)	Ant High (m)
						Peak	Ave.			
5127.20	H	48.40	5.91	54.31	Peak	74	54	-19.69	190	1.23
5149.90	H	36.26	5.96	42.22	Ave	74	54	-11.78	190	1.23
5129.40	V	48.08	5.91	53.99	Peak	74	54	-20.01	35	1.00
5147.90	V	36.27	5.95	42.22	Ave	74	54	-11.78	35	1.00

Notes:

1. Result = Meter Reading + Factor
2. Factor = Antenna Factor + Cable Loss – Amplifier
3. The resolution bandwidth of test receiver/spectrum analyzer is 1MHz and video bandwidth is 3 MHz for Peak detection at frequency above 1GHz.
4. The resolution bandwidth of test receiver/spectrum analyzer is 1MHz and video bandwidth is 10 MHz for Average detection at frequency above 1GHz.

11. Restricted Bands of Operation

Only spurious emissions are permitted in any of the frequency bands listed below:

MHz	MHz	MHz	GHz
0.09000 – 0.11000	16.42000 – 16.42300	399.9 – 410.0	4.500 – 5.250
0.49500 – 0.505**	16.69475 – 16.69525	608.0 – 614.0	5.350 – 5.460
2.17350 – 2.19050	16.80425 – 16.80475	960.0 – 1240.0	7.250 – 7.750
4.12500 – 4.12800	25.50000 – 25.67000	1300.0 – 1427.0	8.025 – 8.500
4.17725 – 4.17775	37.50000 – 38.25000	1435.0 – 1626.5	9.000 – 9.200
4.20725 – 4.20775	73.00000 – 74.60000	1645.5 – 1646.5	9.300 – 9.500
6.21500 – 6.21800	74.80000 – 75.20000	1660.0 – 1710.0	10.600 – 12.700
6.26775 – 6.26825	108.00000 – 121.94000	1718.8 – 1722.2	13.250 – 13.400
6.31175 – 6.31225	123.00000 – 138.00000	2200.0 – 2300.0	14.470 – 14.500
8.29100 – 8.29400	149.90000 – 150.05000	2310.0 – 2390.0	15.350 – 16.200
8.36200 – 8.36600	156.52475 – 156.52525	2483.5 – 2500.0	17.700 – 21.400
8.37625 – 8.38675	156.70000 – 156.90000	2655.0 – 2900.0	22.010 – 23.120
8.41425 – 8.41475	162.01250 – 167.17000	3260.0 – 3267.0	23.600 – 24.000
12.29000 – 12.29300	167.72000 – 173.20000	3332.0 – 3339.0	31.200 – 31.800
12.51975 – 12.52025	240.00000 – 285.00000	3345.8 – 3358.0	36.430 – 36.500
12.57675 – 12.57725	322.00000 – 335.40000	3600.0 – 4400.0	Above 38.6
13.36000 – 13.41000			

** : Until February 1, 1999, this restricted band shall be 0.490-0.510 MHz

11.1. Labeling Requirement

The device shall bear the following statement in a conspicuous location on the device:

This device complies with part 15 of the FCC Rules. Operation is subject to the following two conditions: (1) This device may not cause harmful interference, and (2) this device must accept any interference received, including interference that may cause undesired operation.

12. RF Exposure

FCC Rules and Regulations Part 1.1307, 1.1310, 2.1091, 2.1093:
RF Exposure Compliance

12.1. Limit for Maximum Permissible Exposure (MPE)

(A) Limits for Occupational / Controlled Exposure

Frequency Range (MHz)	Electric Field Strength (E) (V/m)	Magnetic Field Strength (H) (A/m)	Power Density (S) (mW/ cm ²)	Averaging Time E ² , H ² or S (minutes)
0.3-3.0	614	1.63	(100)*	6
3.0-30	1842/f	4.89/f	(900/f)*	6
30-300	61.4	0.163	1.0	6
300-1500			F/300	6
1500-100,000			5	6

(B) Limits for General Population / Uncontrolled Exposure

Frequency Range (MHz)	Electric Field Strength (E) (V/m)	Magnetic Field Strength (H) (A/m)	Power Density (S) (mW/cm ²)	Averaging Time E ² , H ² or S (minutes)
0.3-1.34	614	1.63	(100)*	30
1.34-30	824/f	2.19/f	(180/f)*	30
30-300	27.5	0.073	0.2	30
300-1500			F/1500	30
1500-100,000			1.0	30

F=frequency in MHz

*Plane-wave equivalent power density

12.2. MPE Calculations

$$E \text{ (V/m)} = \frac{\sqrt{30 \times P \times G}}{d} \quad \text{Power Density: } Pd \text{ (mW/cm}^2\text{)} = \frac{E^2}{3770}$$

E = Electric field (V/m)

P = Peak output power (W)

G = Antenna numeric gain (numeric)

d = Separation distance (m)

Because the EUT is belong to General Population/ Uncontrolled Exposure. So the Limit of Power Density is 10 W/m². We can change the formula to:

$$d = \sqrt{\frac{30 \times P \times G}{3770}}$$

12.3. FCC Radiation Exposure Statement

This equipment complies with FCC radiation exposure limits set forth for an uncontrolled environment. In order to avoid the possibility of exceeding the FCC radio frequency exposure limits, human proximity to the antenna shall not be less than 20cm (8 inches) during normal operation. Proposed RF exposure safety information to include in User's Manual.