

Report No.: T210113D03-RP3

5.5. CONDUCTED BANDEDGE AND SPURIOUS EMISSION

5.5.1 Test Limit

According to §15.247(d) and RSS-247 section 5.5,

In any 100 kHz bandwidth outside the authorized frequency band,

Non-restricted bands shall be attenuated at least 20 dB/30 dB relative to the maximum PSD level in 100 kHz by RF conducted or a radiated measurement which fall in the restricted bands, as defined in §15.205(a), must also comply with the radiated emission limits specified in §15.209(a).

5.5.2 Test Procedure

Test method Refer as ANSI C63.10:2013.

1. EUT RF output port connected to the SA by RF cable, and the path loss was compensated to result.
2. SA setting, RBW=100kHz, VBW=300kHz, Detector=Peak, Trace mode = max hold, SWT = Auto.
3. In any 100 kHz bandwidth outside the authorized frequency band, shall be attenuated at least 20 dB relative to the maximum in-band peak PSD level in 100 kHz when conducted power procedure is used. If the transmitter complies with the conducted power limits based on the use of RMS averaging over a time interval, the attenuation required under this paragraph shall be 30 dB instead of 20 dB.

5.5.3 Test Setup

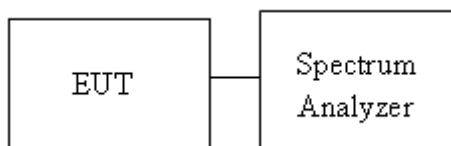

Report No.: T210113D03-RP3

5.5.4 Test Result

Test Data

Temperature: 25.8°C

Tested by: Jack Chen

Humidity: 46.3% RH

Test date: June 9, 2021

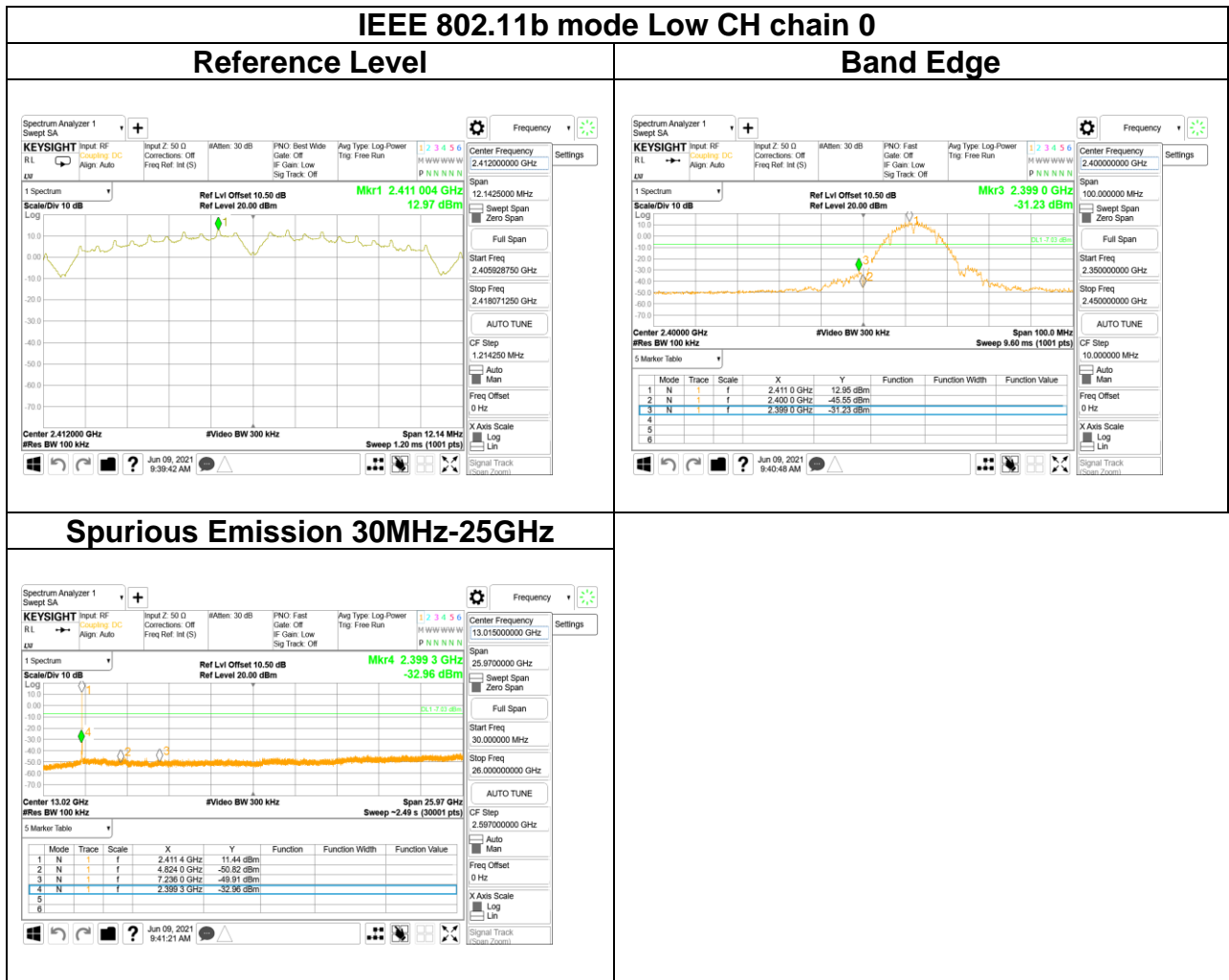

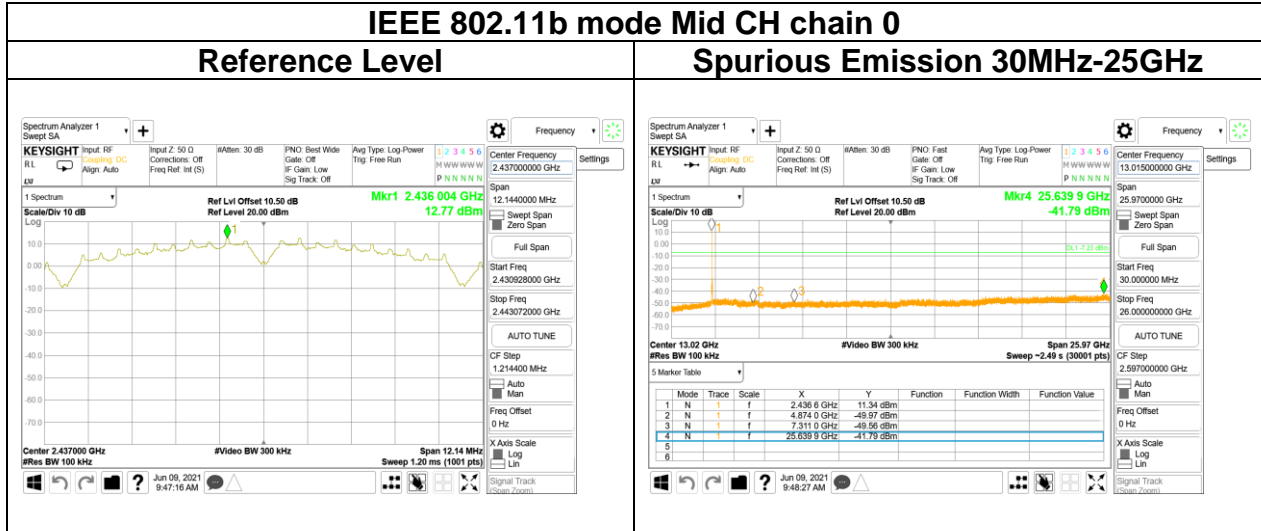

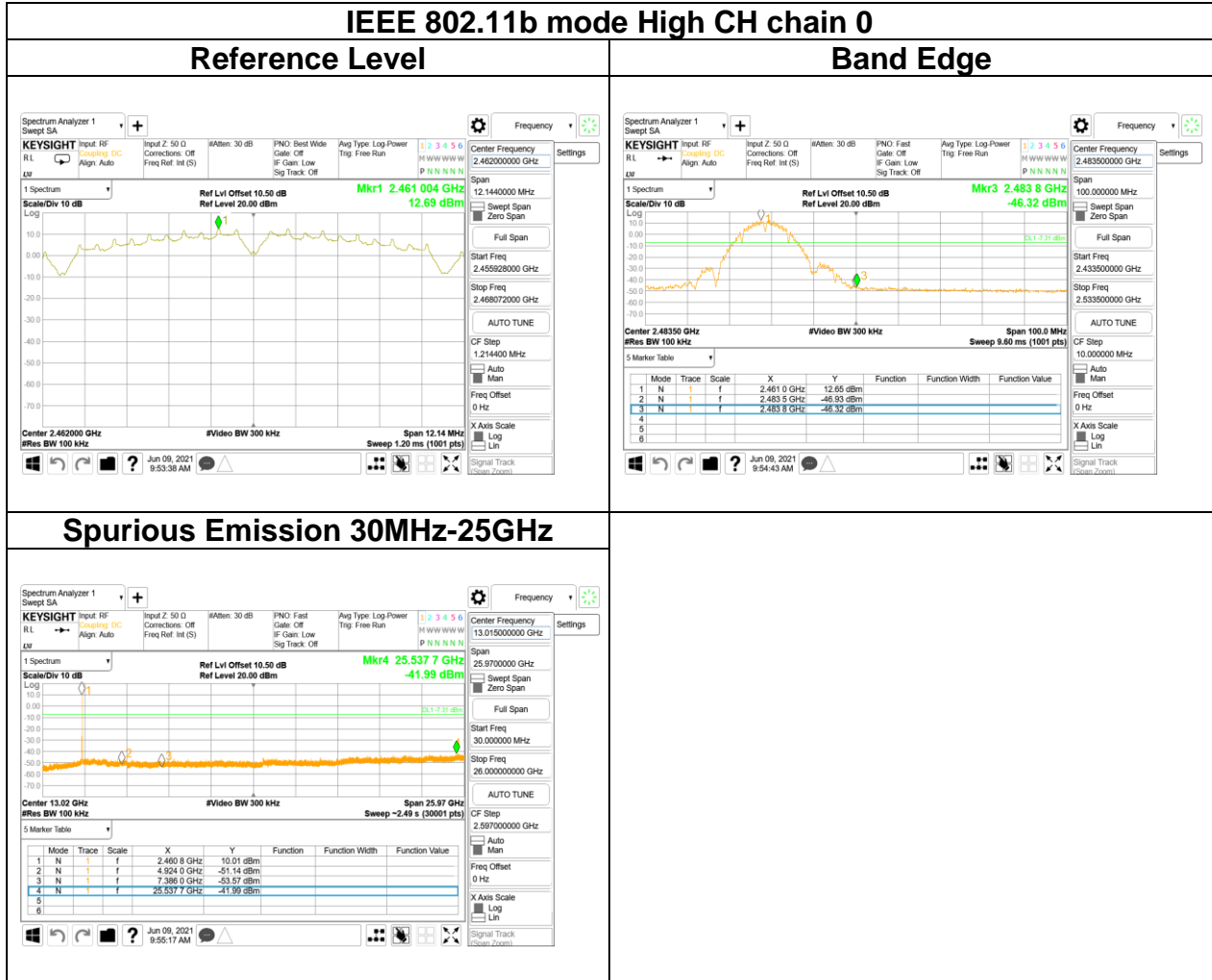

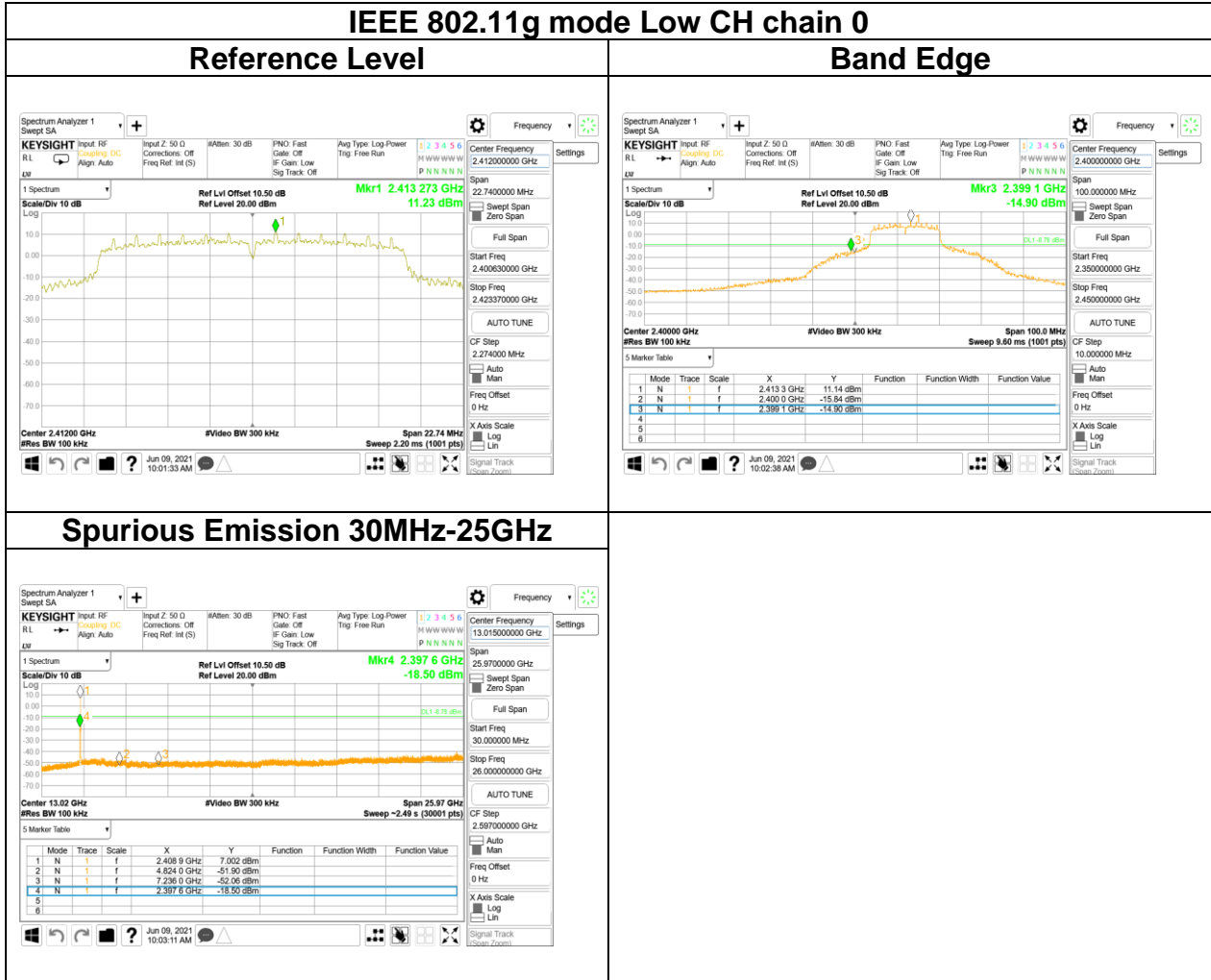

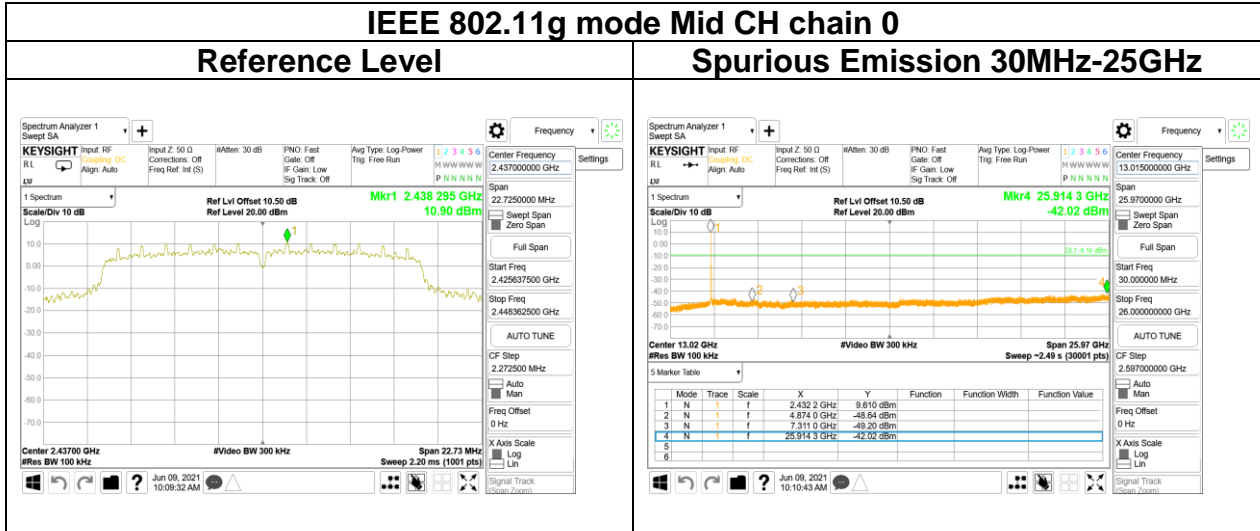

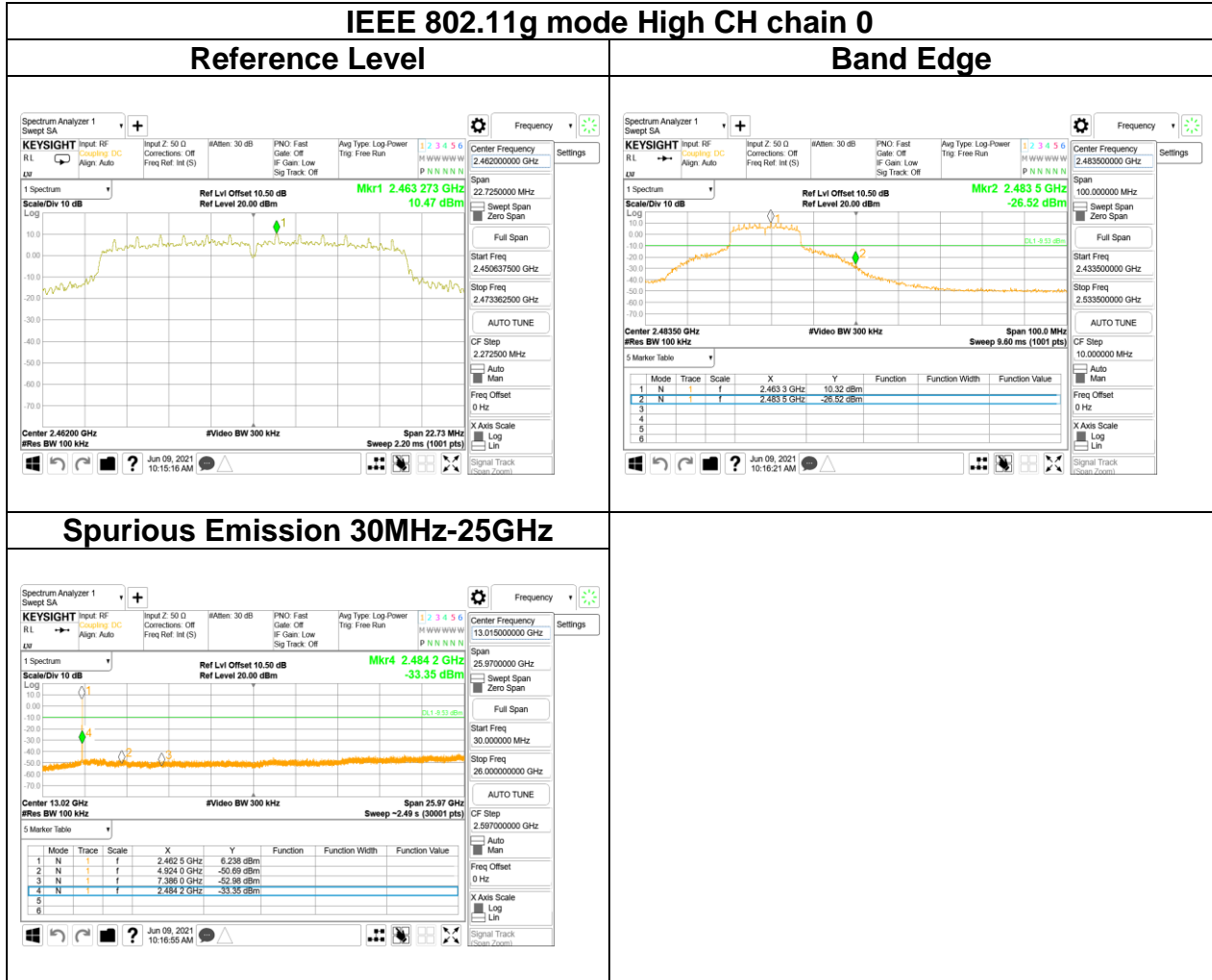

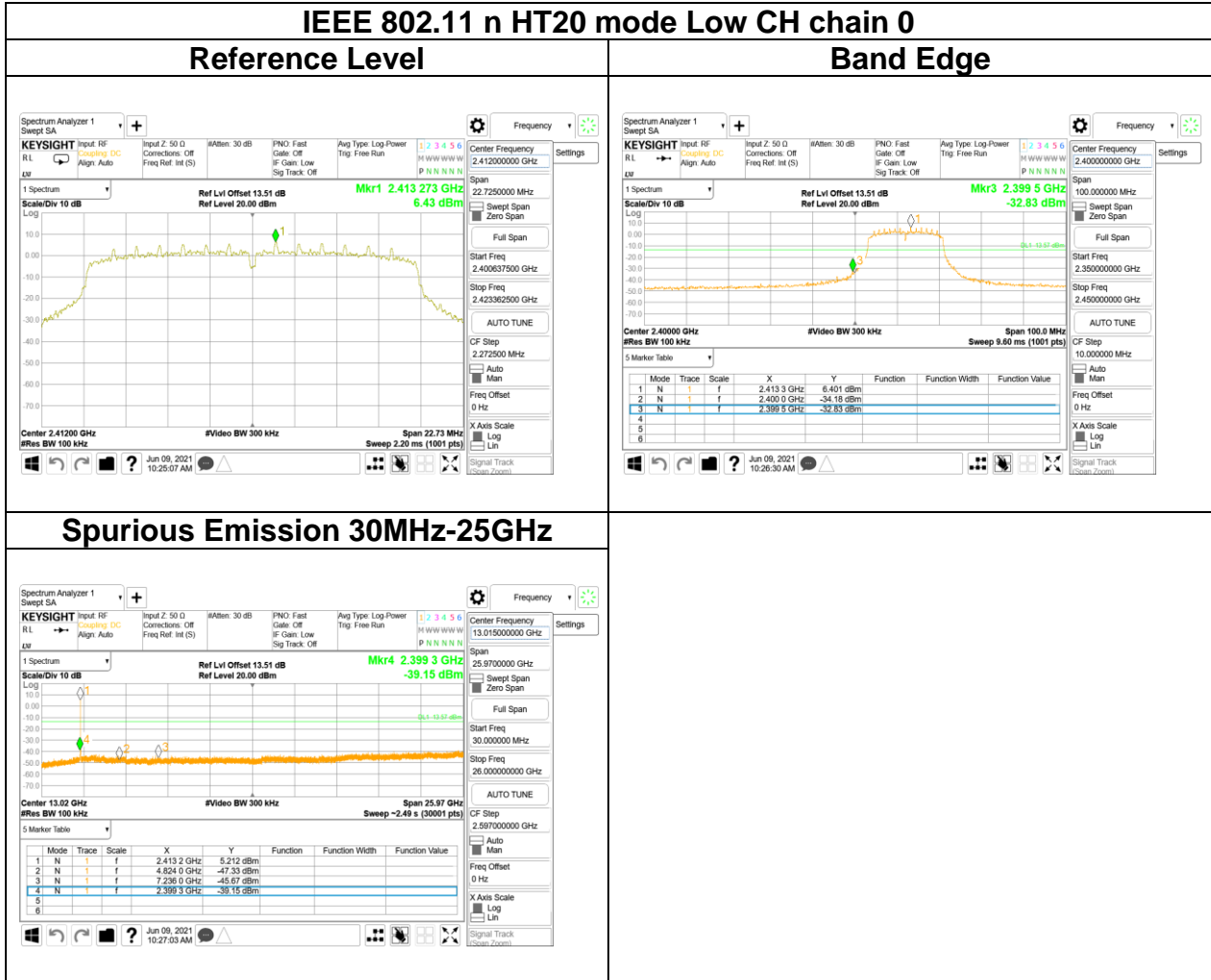

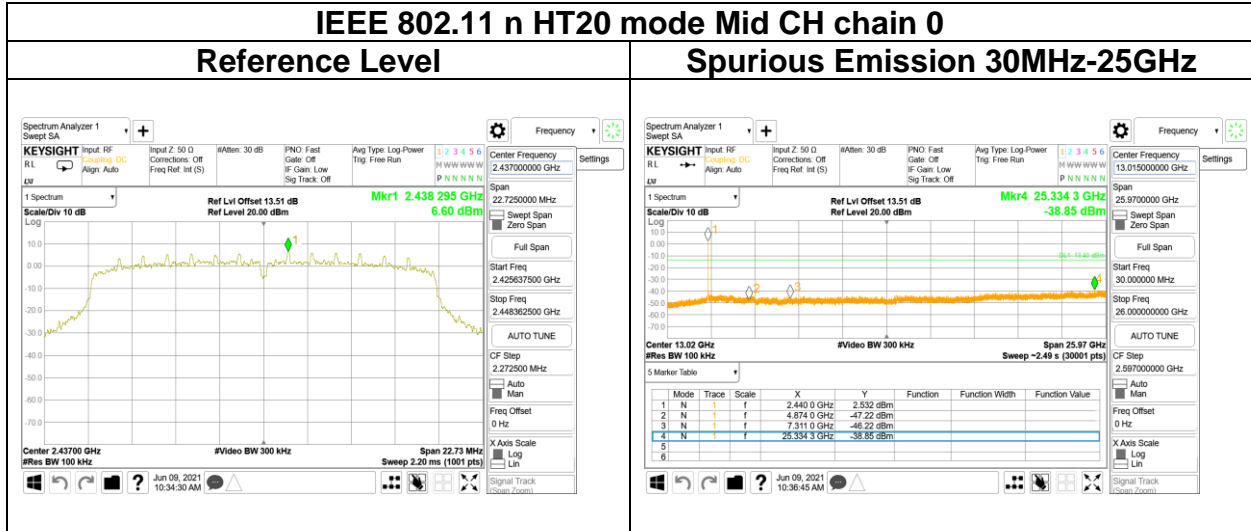

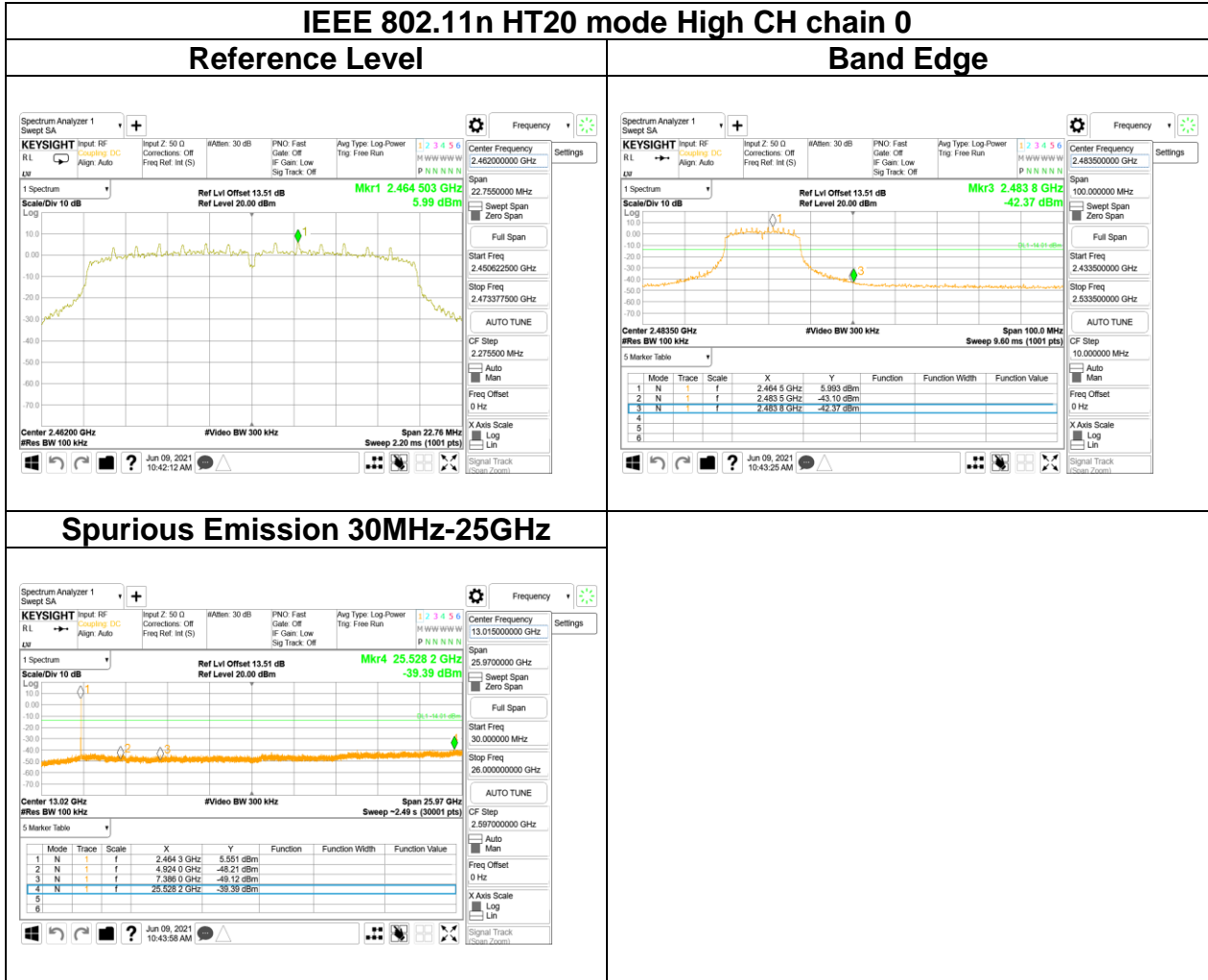

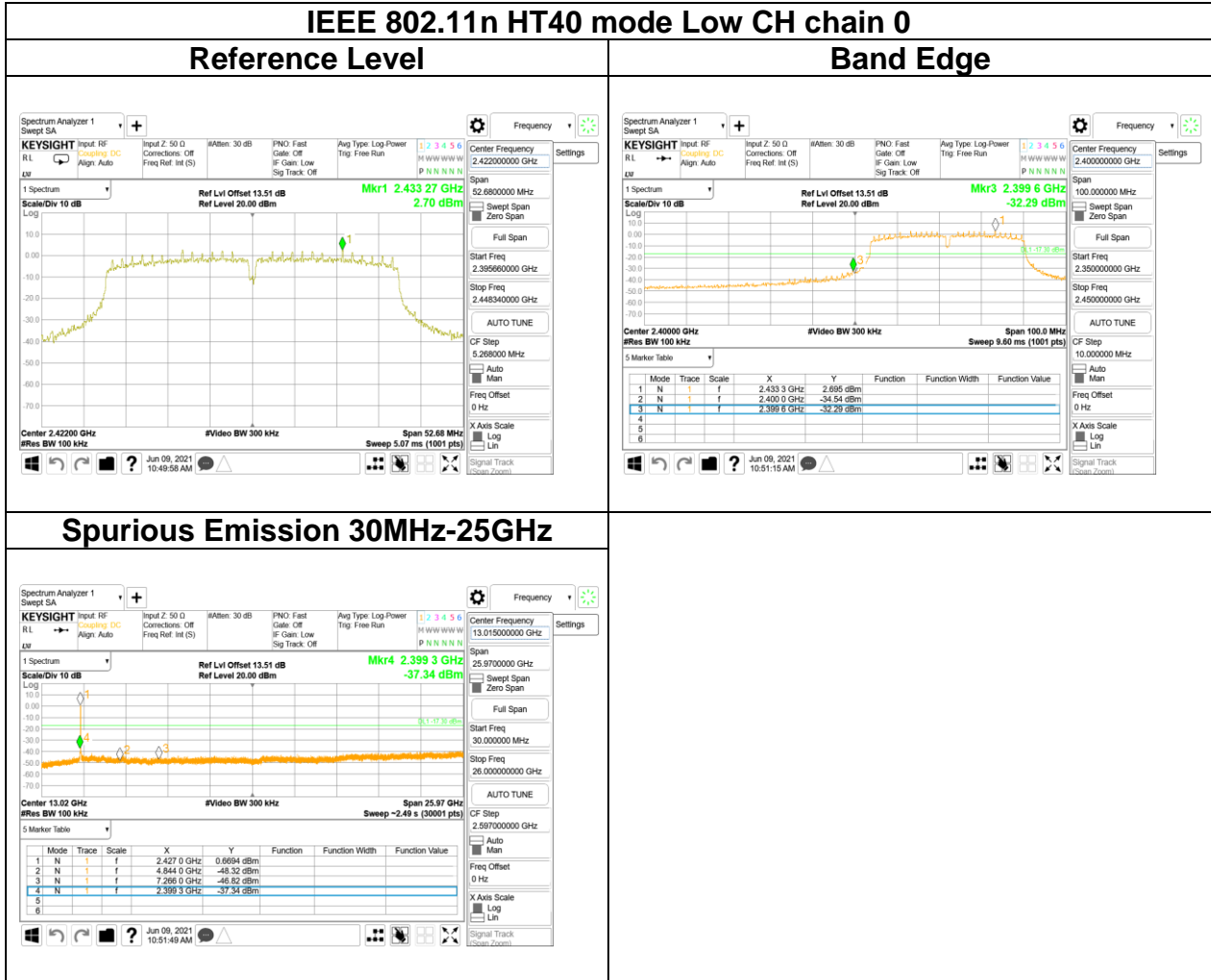

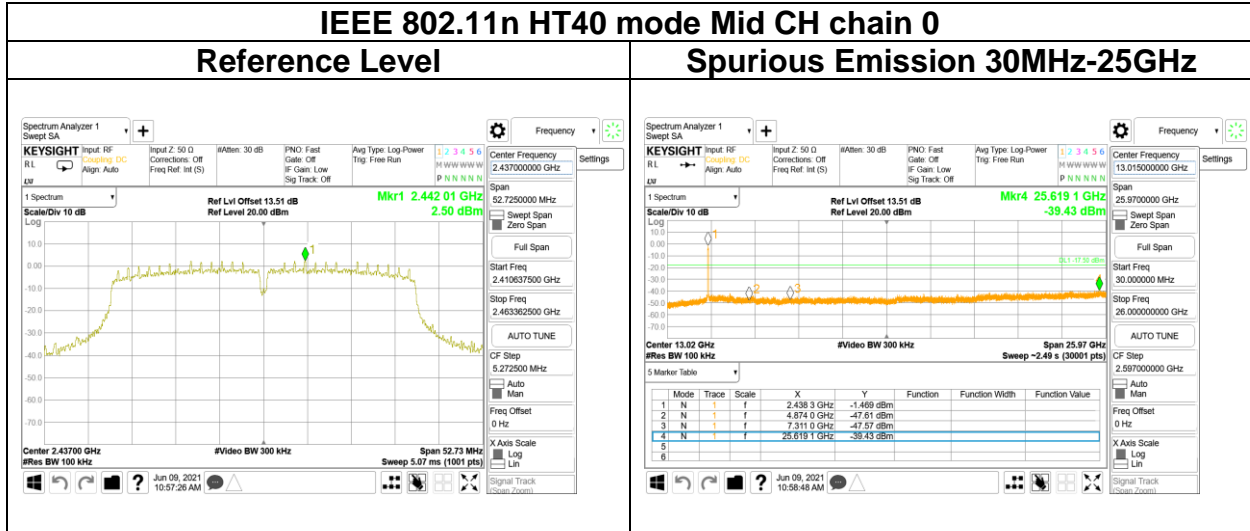

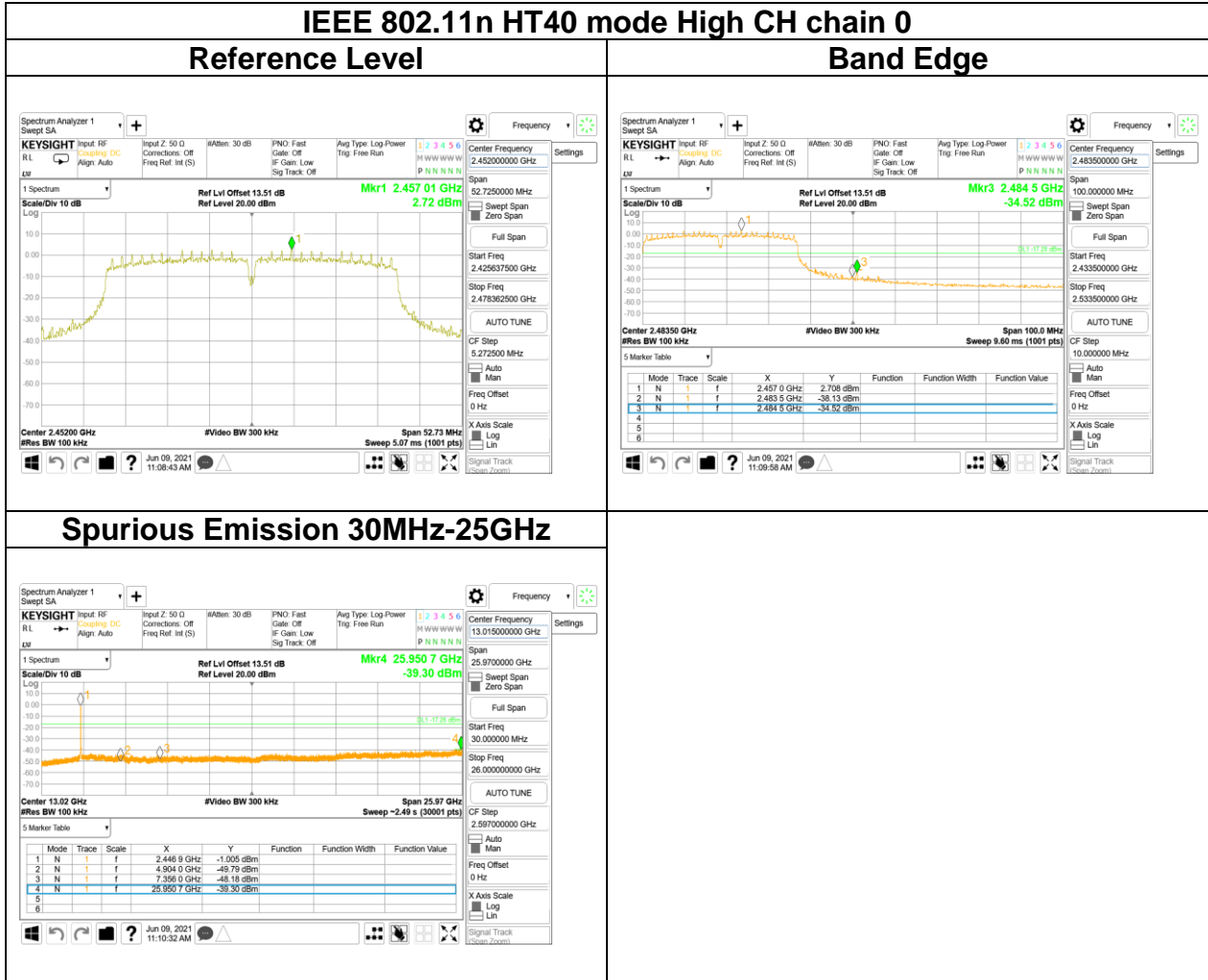

5.6. RADIATION BANDEGE AND SPURIOUS EMISSION

5.6.1 Test Limit

FCC according to §15.247(d), §15.209 and §15.205,

IC according to RSS-247 section 5.5, RSS-Gen, Section 8.9 and 8.10

In any 100 kHz bandwidth outside the authorized frequency band, all harmonic and spurious must be least 20 dB below the highest emission level with the authorized frequency band. Radiation emission which fall in the restricted bands must also follow the FCC section 15.209 as below limit in table.

Below 30 MHz

Frequency	Field Strength (microvolts/m)	Magnetic H-Field (microamperes/m)	Measurement Distance (metres)
9-490 kHz	2,400/F (F in kHz)	2,400/F (F in kHz)	300
490-1,705 kHz	24,000/F (F in kHz)	24,000/F (F in kHz)	30
1.705-30 MHz	30	N/A	30

Above 30 MHz

Frequency	Field Strength (microvolts/m)	Measurement Distance (metres)
30-88	100	3
88-216	150	3
216-960	200	3
Above 960	500	3

Remark:

Although these tests were performed other than open area test site, adequate comparison measurements were confirmed against 30 m open are test site. Therefore sufficient tests were made to demonstrate that the alternative site produces results that correlate with the ones of tests made in an open field based on KDB 414788.

IC according to RSS-247 section 5.5, RSS-Gen, Section 8.9 and 8.10

RSS-Gen Table 3 and Table 5 – General Field Strength Limits for Transmitters and Receivers at Frequencies Above 30 MHz ^(Note)

Frequency (MHz)	Field Strength microvolts/m at 3 metres (watts, e.i.r.p.)	
	Transmitters	Receivers
30-88	100 (3 nW)	100 (3 nW)
88-216	150 (6.8 nW)	150 (6.8 nW)
216-960	200 (12 nW)	200 (12 nW)
Above 960	500 (75 nW)	500 (75 nW)

Note: Measurements for compliance with the limits in table 3 may be performed at distances other than 3 metres, in accordance with Section 6.6.

RSS-Gen Table 6: General Field Strength Limits for Transmitters at Frequencies Below 30 MHz (Transmit)

Frequency	Magnetic field strength (H-Field) (µA/m)	Measurement Distance (m)
9-490 kHz ^{Note}	6.37/F (F in kHz)	300
490-1,705 kHz	63.7/F (F in kHz)	30
1.705-30 MHz	0.08	30

Note: The emission limits for the ranges 9-90 kHz and 110-490 kHz are based on measurements employing a linear average detector.

Report No.: T210113D03-RP3

5.6.2 Test Procedure

Test method Refer as ANSI C63.10:2013.

1. The EUT is placed on a turntable, Above 1 GHz is 1.5m and below 1 GHz is 0.8m above ground plane. The EUT Configured un accordance with ANSI C63.10: 2013, and the EUT set in a continuous mode.
2. The turntable shall be rotated for 360 degrees to determine the position of maximum emission level. And EUT is set 3m away from the receiving antenna, which is scanned from 1m to 4m above the ground plane to find out the highest emissions. Measurement are made polarized in both the vertical and the horizontal positions with antenna.
3. Span shall wide enough to full capture the emission measured. The SA from 9kHz to 26.5GHz set to the low, Mid and High channels with the EUT transmit.

Note: No emission found between lowest internal used/generated frequency to 30MHz (9KHz~30MHz)

Remark:

Although these tests were performed other than open area test site, adequate comparison measurements were confirmed against 30 m open are test site. Therefore sufficient tests were made to demonstrate that the alternative site produces results that correlate with the ones of tests made in an open field based on KDB 414788.

4. The SA setting following :

- (1) Below 1G : RBW = 100kHz, VBW \geq 3 RBW, Sweep = Auto, Detector = Peak, Trace = Max hold.
- (2) Above 1G :
 - (2.1) For Peak measurement : RBW = 1MHz, VBW \geq 3 RBW, Sweep = Auto, Detector = Peak, Trace = Max hold.
 - (2.2) For Average measurement : RBW = 1MHz, VBW
 - 'If Duty Cycle \geq 98%, VBW=10Hz.
 - 'If Duty Cycle < 98%, VBW=1/T.

5.6.3 Test Setup

9kHz ~ 30MHz

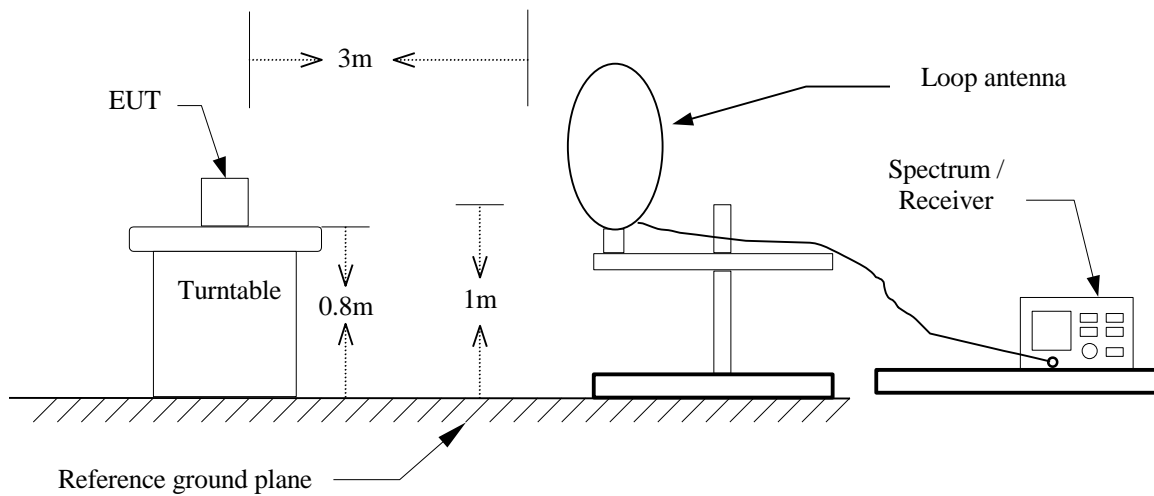

30MHz ~ 1GHz

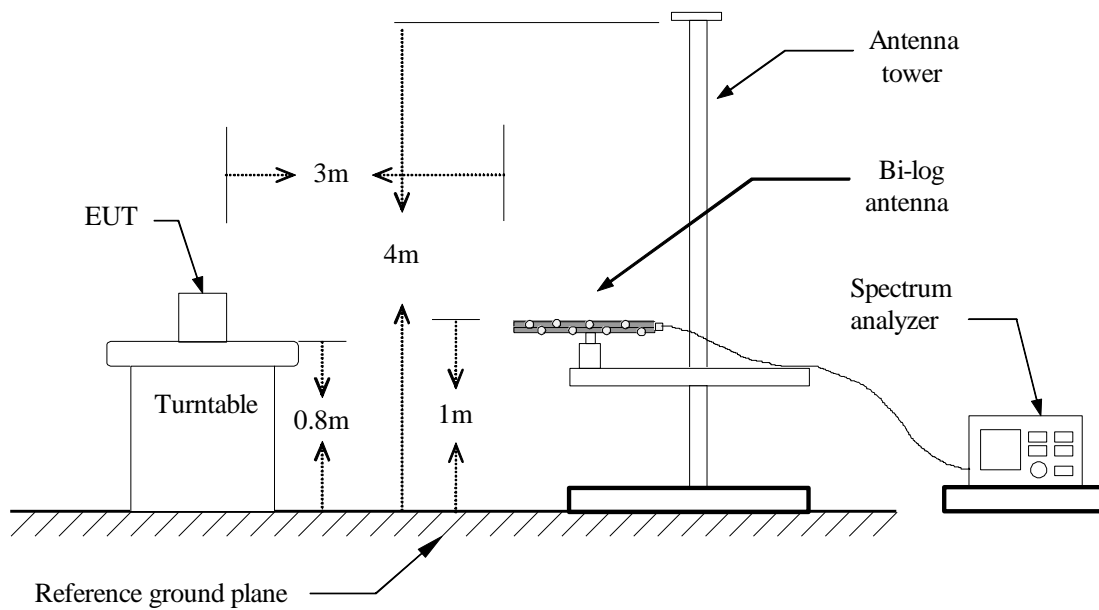

Above 1 GHz

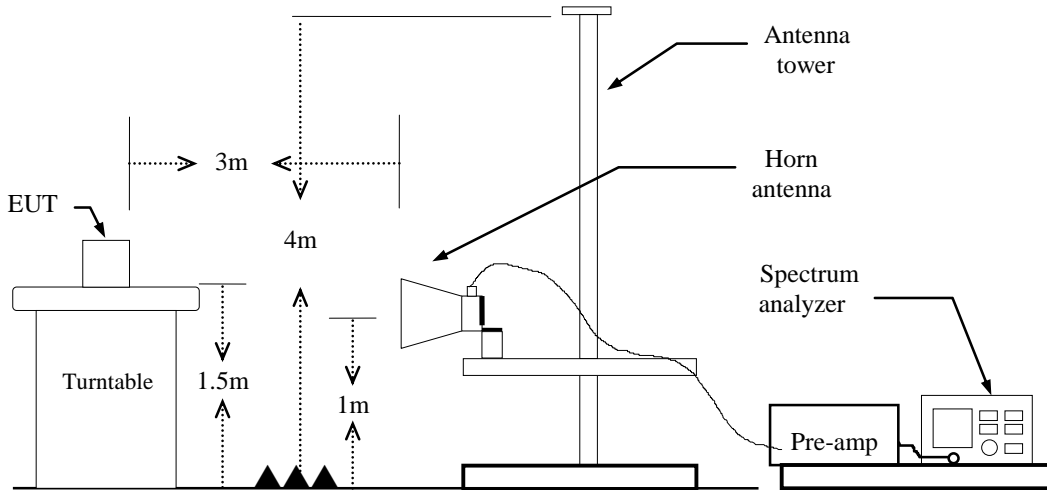

5.6.4 Test Result

Band Edge Test Data

Test Mode	IEEE 802.11b Low CH 2412MHz	Temp/Hum	22.4(°C)/ 62%RH
Test Item	Band Edge	Test Date	April 15, 2021
Polarize	Vertical	Test Engineer	Ray Li
Detector	Peak / Average		

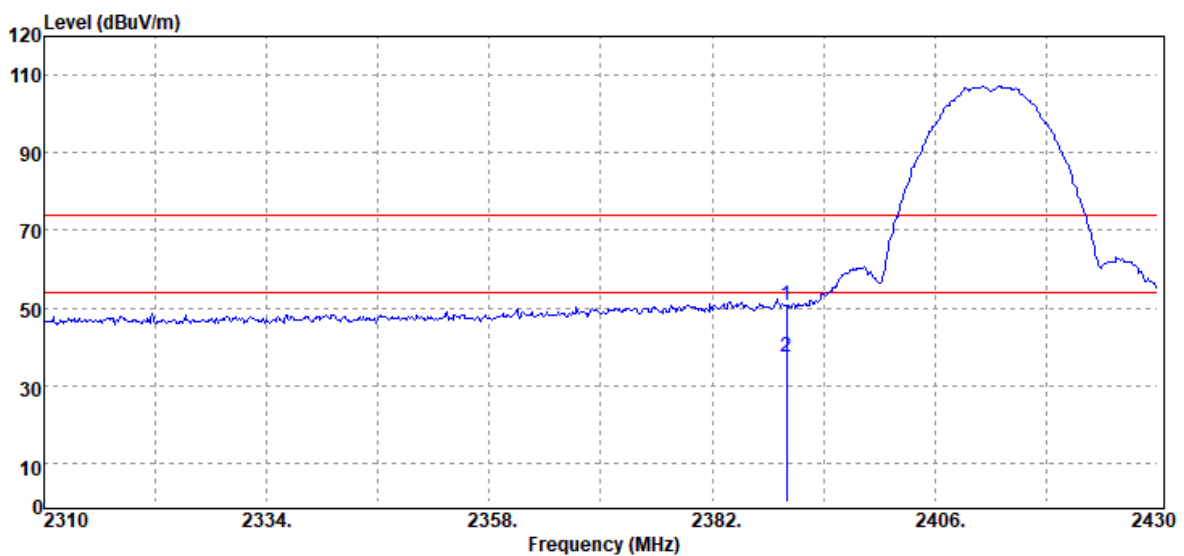

Frequency (MHz)	Detector Mode (PK/QP/AV)	Spectrum Reading Level (dBμV)	Factor (dB)	Actual FS (dBμV/m)	Limit @3m (dBμV/m)	Margin (dB)
2390.00	Peak	51.59	-1.00	50.59	74.00	-23.41
2390.00	Average	38.26	-1.00	37.26	54.00	-16.74

Test Mode	IEEE 802.11b Low CH 2412MHz	Temp/Hum	22.4(°C)/ 62%RH
Test Item	Band Edge	Test Date	April 15, 2021
Polarize	Horizontal	Test Engineer	Ray Li
Detector	Peak / Average		

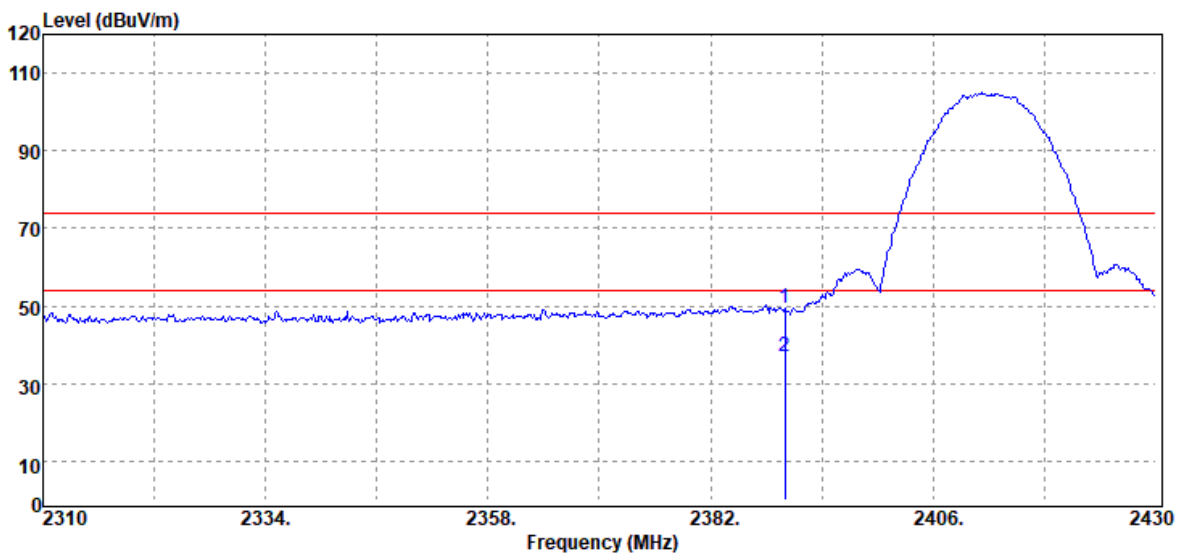

Frequency (MHz)	Detector Mode (PK/QP/AV)	Spectrum Reading Level (dBμV)	Factor (dB)	Actual FS (dBμV/m)	Limit @3m (dBμV/m)	Margin (dB)
2390.00	Peak	50.46	-1.00	49.46	74.00	-24.54
2390.00	Average	38.08	-1.00	37.08	54.00	-16.92

Test Mode	IEEE 802.11b High CH 2462MHz	Temp/Hum	22.4(°C)/ 62%RH
Test Item	Band Edge	Test Date	April 15, 2021
Polarize	Vertical	Test Engineer	Ray Li
Detector	Peak / Average		

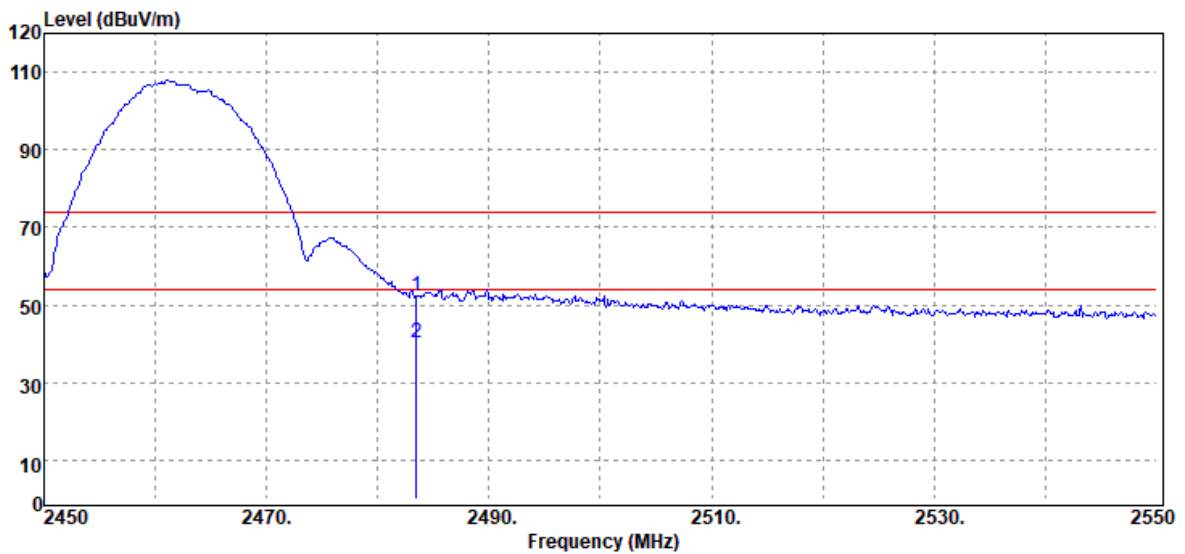

Frequency (MHz)	Detector Mode (PK/QP/AV)	Spectrum Reading Level (dB μ V)	Factor (dB)	Actual FS (dB μ V/m)	Limit @3m (dB μ V/m)	Margin (dB)
2483.50	Peak	52.93	-0.66	52.27	74.00	-21.73
2483.50	Average	40.81	-0.66	40.15	54.00	-13.85

Test Mode	IEEE 802.11b High CH 2462MHz	Temp/Hum	22.4(°C)/ 62%RH
Test Item	Band Edge	Test Date	April 15, 2021
Polarize	Horizontal	Test Engineer	Ray Li
Detector	Peak / Average		

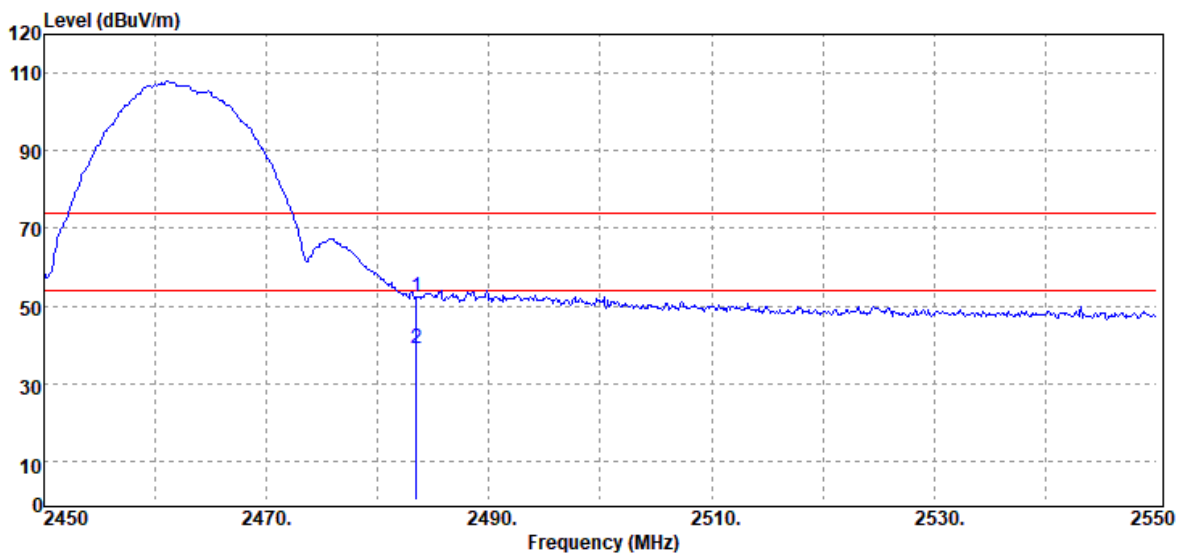

Frequency (MHz)	Detector Mode (PK/QP/AV)	Spectrum Reading Level (dB μ V)	Factor (dB)	Actual FS (dB μ V/m)	Limit @3m (dB μ V/m)	Margin (dB)
2483.50	Peak	52.93	-0.66	52.27	74.00	-21.73
2483.50	Average	39.60	-0.66	38.94	54.00	-15.06

Test Mode	IEEE 802.11g Low CH 2412MHz	Temp/Hum	22.4(°C)/ 62%RH
Test Item	Band Edge	Test Date	April 15, 2021
Polarize	Vertical	Test Engineer	Ray Li
Detector	Peak / Average		

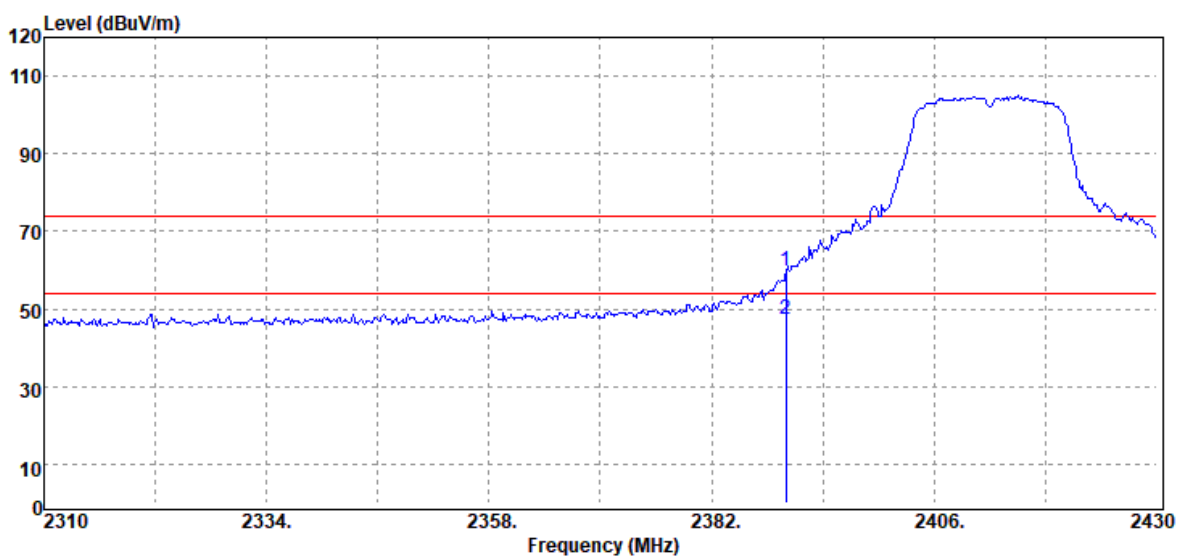

Frequency (MHz)	Detector Mode (PK/QP/AV)	Spectrum Reading Level (dBμV)	Factor (dB)	Actual FS (dBμV/m)	Limit @3m (dBμV/m)	Margin (dB)
2390.00	Peak	60.72	-1.00	59.72	74.00	-14.28
2390.00	Average	48.49	-1.00	47.49	54.00	-6.51

Report No.: T210113D03-RP3

Test Mode	IEEE 802.11g Low CH 2412MHz	Temp/Hum	22.4(°C)/ 62%RH
Test Item	Band Edge	Test Date	April 15, 2021
Polarize	Horizontal	Test Engineer	Ray Li
Detector	Peak / Average		

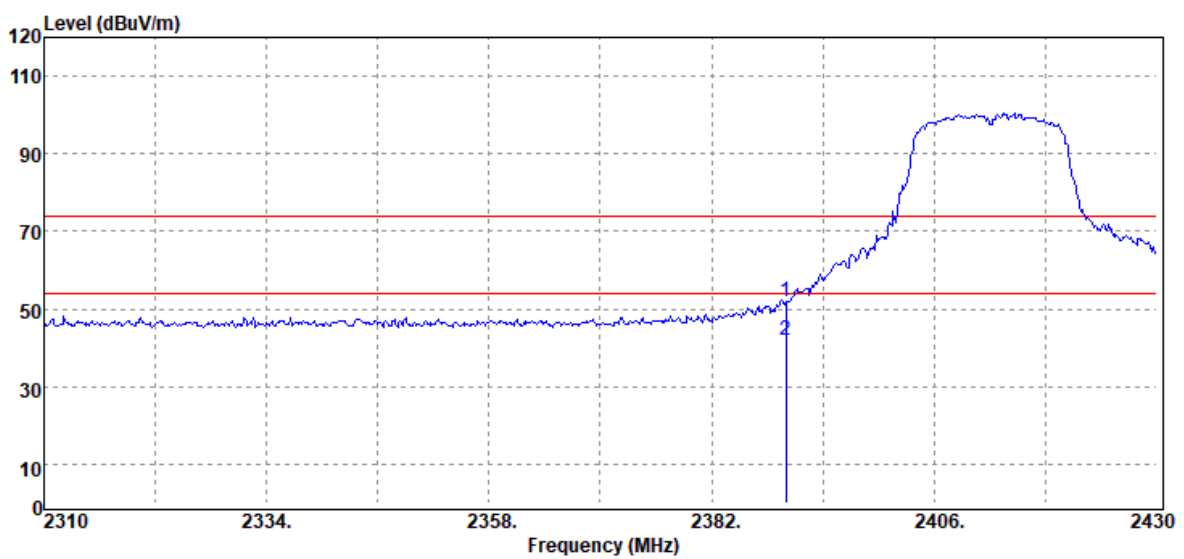

Frequency (MHz)	Detector Mode (PK/QP/AV)	Spectrum Reading Level (dB μ V)	Factor (dB)	Actual FS (dB μ V/m)	Limit @3m (dB μ V/m)	Margin (dB)
2390.00	Peak	52.88	-1.00	51.88	74.00	-22.12
2390.00	Average	42.81	-1.00	41.81	54.00	-12.19

Test Mode	IEEE 802.11g High CH 2462MHz	Temp/Hum	22.4(°C)/ 62%RH
Test Item	Band Edge	Test Date	April 15, 2021
Polarize	Vertical	Test Engineer	Ray Li
Detector	Peak / Average		

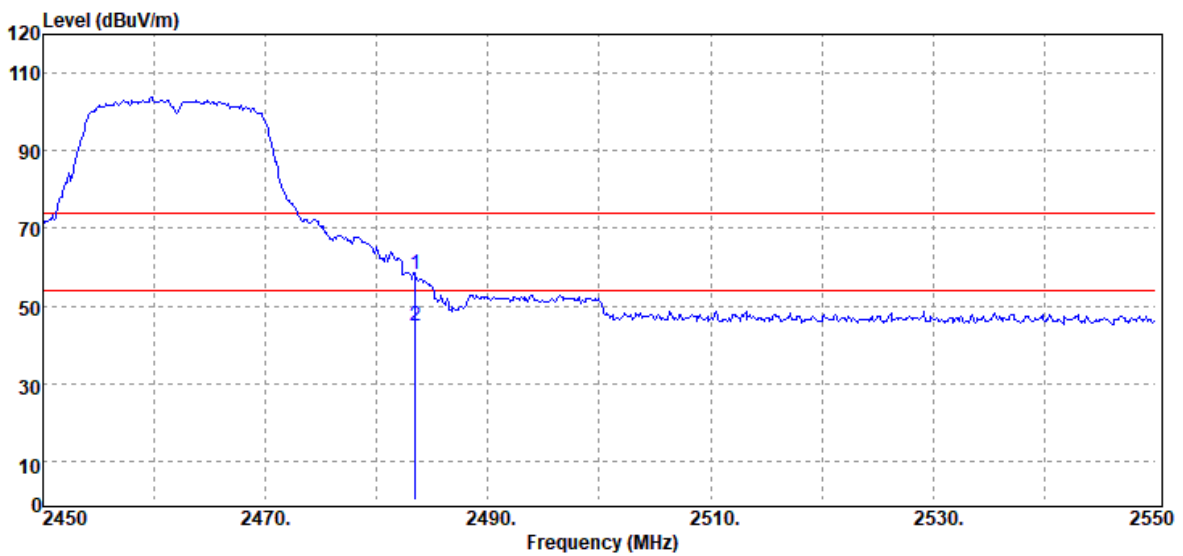

Frequency (MHz)	Detector Mode (PK/QP/AV)	Spectrum Reading Level (dB μ V)	Factor (dB)	Actual FS (dB μ V/m)	Limit @3m (dB μ V/m)	Margin (dB)
2483.50	Peak	58.97	-0.66	58.31	74.00	-15.69
2483.50	Average	45.54	-0.66	44.88	54.00	-9.12

Test Mode	IEEE 802.11g High CH 2462MHz	Temp/Hum	22.4(°C)/ 62%RH
Test Item	Band Edge	Test Date	April 15, 2021
Polarize	Horizontal	Test Engineer	Ray Li
Detector	Peak / Average		

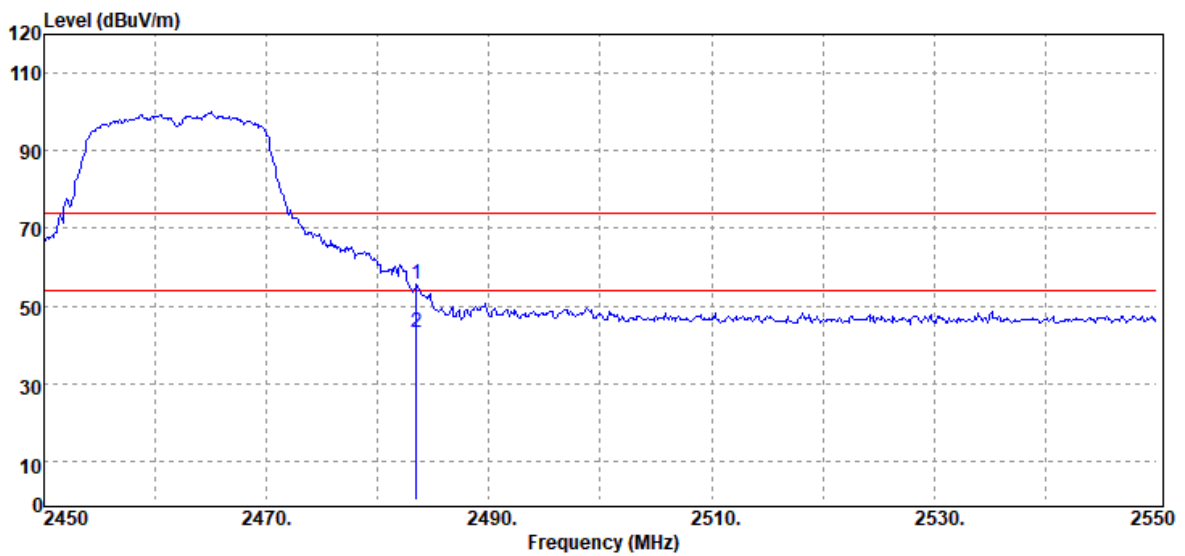

Frequency (MHz)	Detector Mode (PK/QP/AV)	Spectrum Reading Level (dB μ V)	Factor (dB)	Actual FS (dB μ V/m)	Limit @3m (dB μ V/m)	Margin (dB)
2483.50	Peak	56.22	-0.66	55.56	74.00	-18.44
2483.50	Average	43.85	-0.66	43.19	54.00	-10.81

Test Mode	IEEE 802.11n HT20 Low CH 2412MHz	Temp/Hum	22.4(°C)/ 62%RH
Test Item	Band Edge	Test Date	April 15, 2021
Polarize	Vertical	Test Engineer	Ray Li
Detector	Peak / Average		

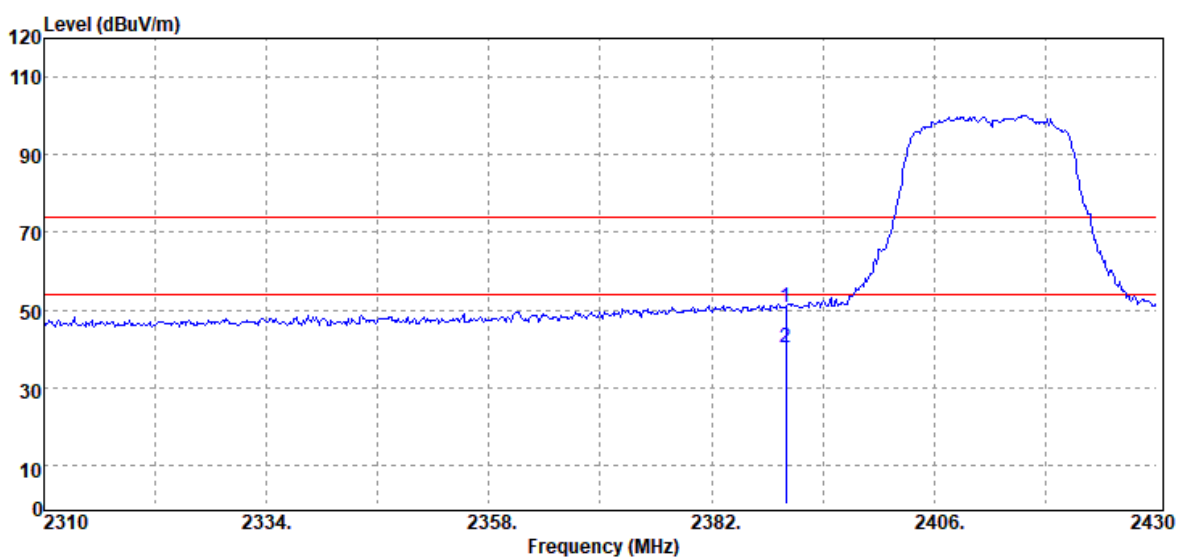

Frequency (MHz)	Detector Mode (PK/QP/AV)	Spectrum Reading Level (dB μ V)	Factor (dB)	Actual FS (dB μ V/m)	Limit @3m (dB μ V/m)	Margin (dB)
2390.00	Peak	51.49	-1.00	50.49	74.00	-23.51
2390.00	Average	41.33	-1.00	40.33	54.00	-13.67

Test Mode	IEEE 802.11 n20 Low CH 2412MHz	Temp/Hum	22.4(°C)/ 62%RH
Test Item	Band Edge	Test Date	April 15, 2021
Polarize	Horizontal	Test Engineer	Ray Li
Detector	Peak / Average		

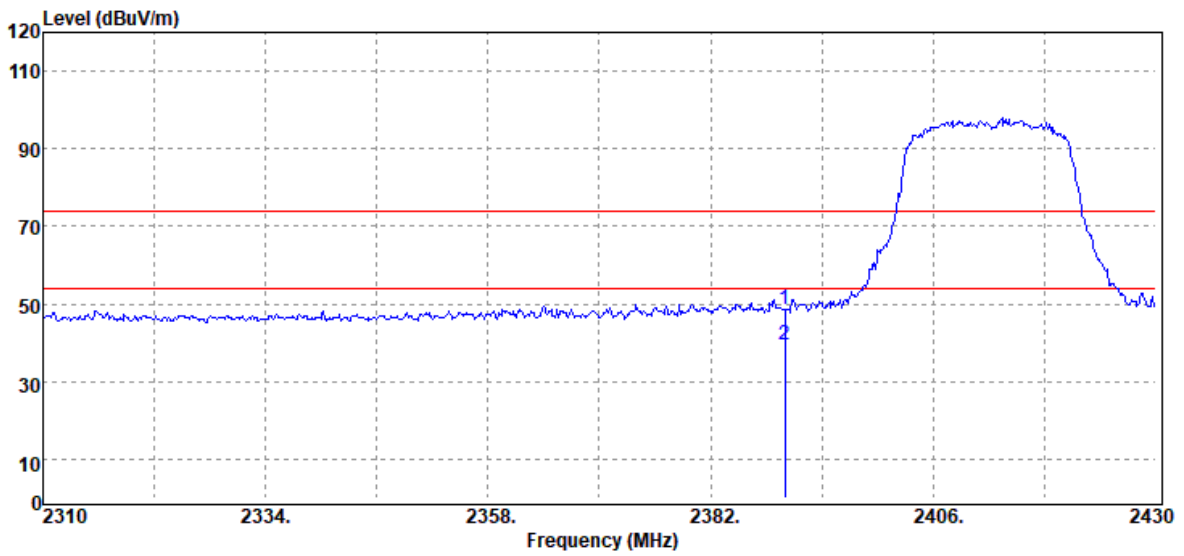

Frequency (MHz)	Detector Mode (PK/QP/AV)	Spectrum Reading Level (dBμV)	Factor (dB)	Actual FS (dBμV/m)	Limit @3m (dBμV/m)	Margin (dB)
2390.00	Peak	49.64	-1.00	48.64	74.00	-25.36
2390.00	Average	40.56	-1.00	39.56	54.00	-14.44

Test Mode	IEEE 802.11n HT20 High CH 2462MHz	Temp/Hum	22.4(°C)/ 62%RH
Test Item	Band Edge	Test Date	April 15, 2021
Polarize	Vertical	Test Engineer	Ray Li
Detector	Peak / Average		

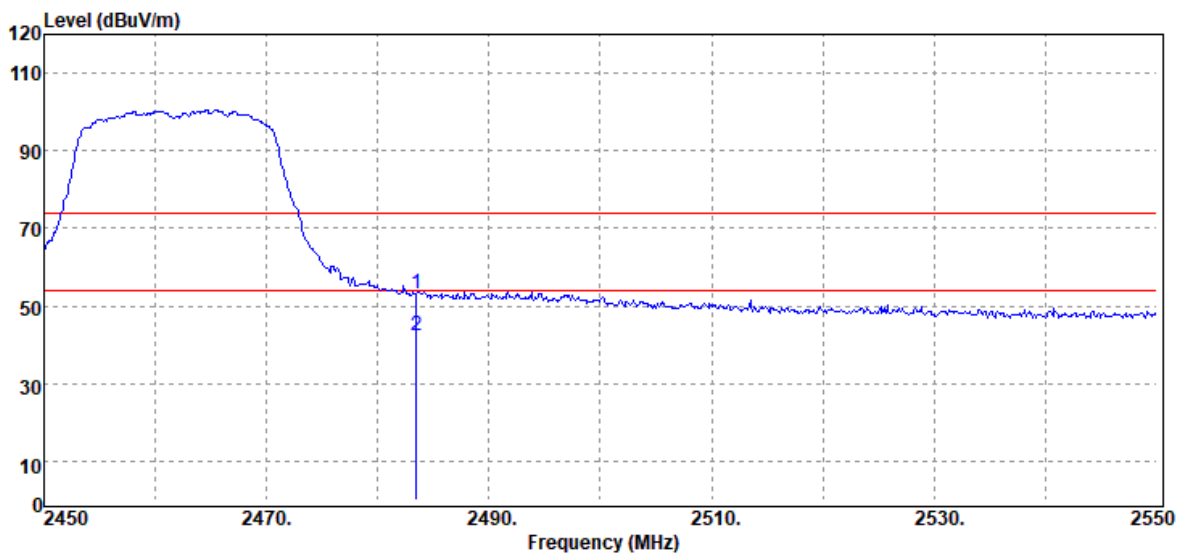

Frequency (MHz)	Detector Mode (PK/QP/AV)	Spectrum Reading Level (dBμV)	Factor (dB)	Actual FS (dBμV/m)	Limit @3m (dBμV/m)	Margin (dB)
2483.50	Peak	53.98	-0.66	53.32	74.00	-20.68
2483.50	Average	42.84	-0.66	42.18	54.00	-11.82

Test Mode	IEEE 802.11n20 High CH 2462MHz	Temp/Hum	22.4(°C)/ 62%RH
Test Item	Band Edge	Test Date	April 15, 2021
Polarize	Horizontal	Test Engineer	Ray Li
Detector	Peak / Average		

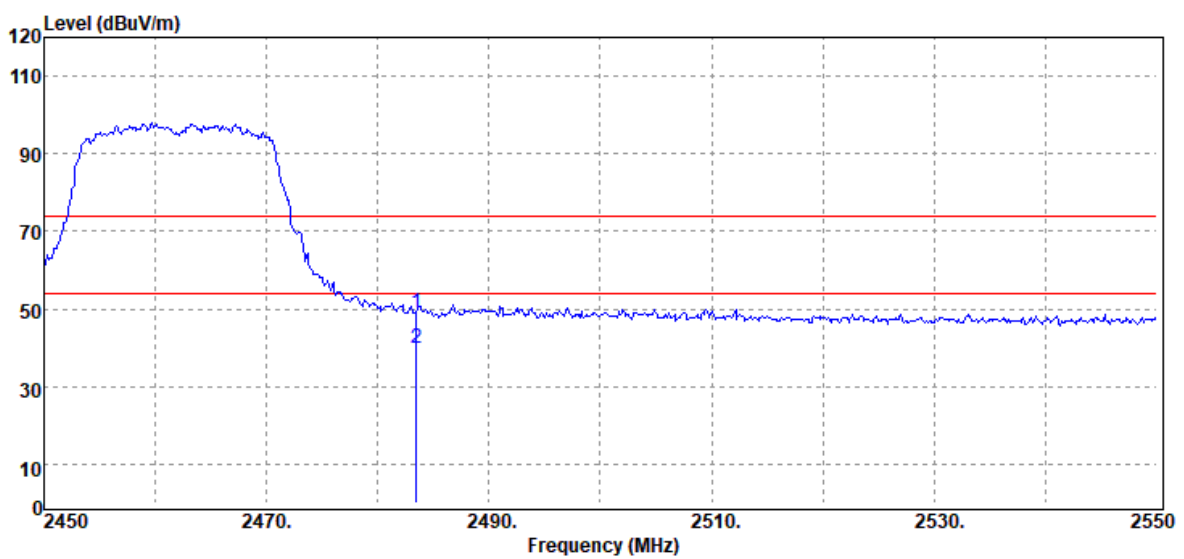

Frequency (MHz)	Detector Mode (PK/QP/AV)	Spectrum Reading Level (dBμV)	Factor (dB)	Actual FS (dBμV/m)	Limit @3m (dBμV/m)	Margin (dB)
2483.50	Peak	49.82	-0.66	49.16	74.00	-24.84
2483.50	Average	40.47	-0.66	39.81	54.00	-14.19

Test Mode	IEEE 802.11n HT40 Low CH 2422MHz	Temp/Hum	22.4(°C)/ 62%RH
Test Item	Band Edge	Test Date	April 16, 2021
Polarize	Vertical	Test Engineer	Ray Li
Detector	Peak / Average		

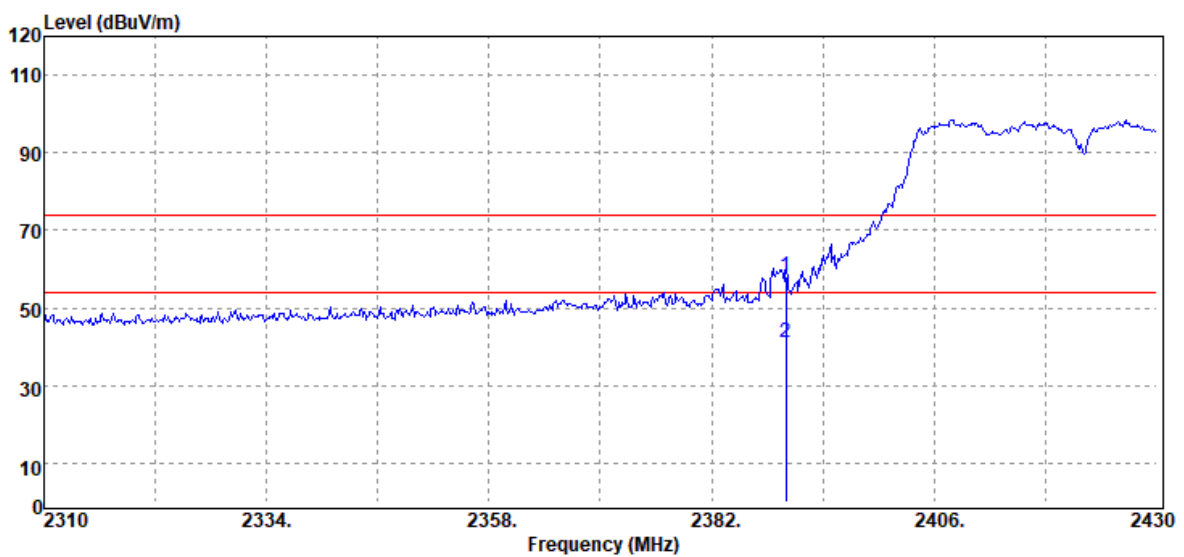

Frequency (MHz)	Detector Mode (PK/QP/AV)	Spectrum Reading Level (dB μ V)	Factor (dB)	Actual FS (dB μ V/m)	Limit @3m (dB μ V/m)	Margin (dB)
2390.00	Peak	59.30	-1.00	58.30	74.00	-15.70
2390.00	Average	42.30	-1.00	41.30	54.00	-12.70

Test Mode	IEEE 802.11 n40 Low CH 2422MHz	Temp/Hum	22.4(°C)/ 62%RH
Test Item	Band Edge	Test Date	April 16, 2021
Polarize	Horizontal	Test Engineer	Ray Li
Detector	Peak / Average		

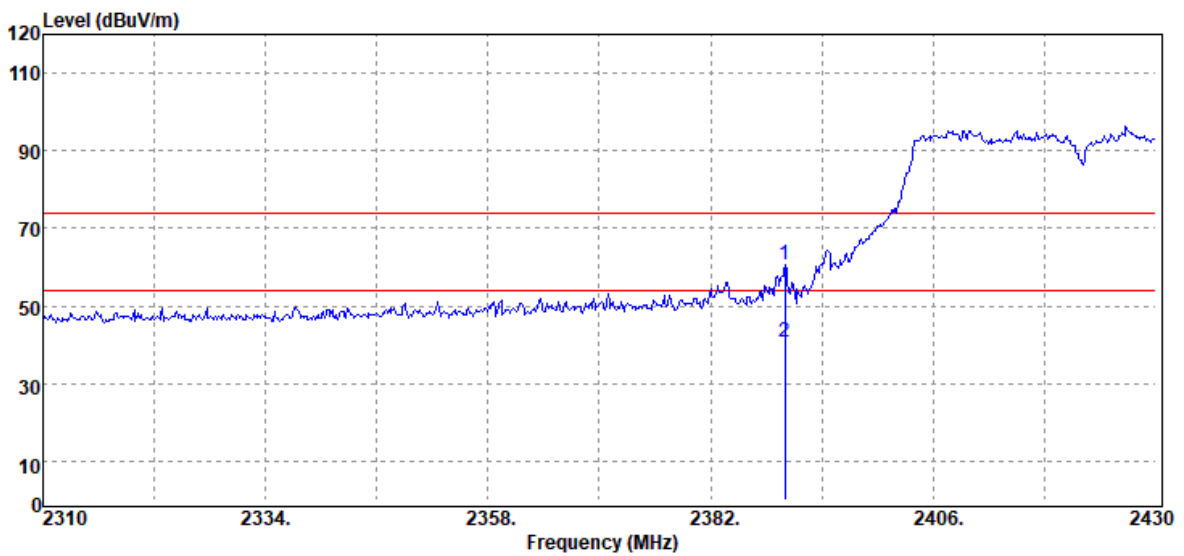

Frequency (MHz)	Detector Mode (PK/QP/AV)	Spectrum Reading Level (dBμV)	Factor (dB)	Actual FS (dBμV/m)	Limit @3m (dBμV/m)	Margin (dB)
2390.00	Peak	61.69	-1.00	60.69	74.00	-13.31
2390.00	Average	41.56	-1.00	40.56	54.00	-13.44

Test Mode	IEEE 802.11n HT40 High CH 2452MHz	Temp/Hum	22.4(°C)/ 62%RH
Test Item	Band Edge	Test Date	April 16, 2021
Polarize	Vertical	Test Engineer	Ray Li
Detector	Peak / Average		

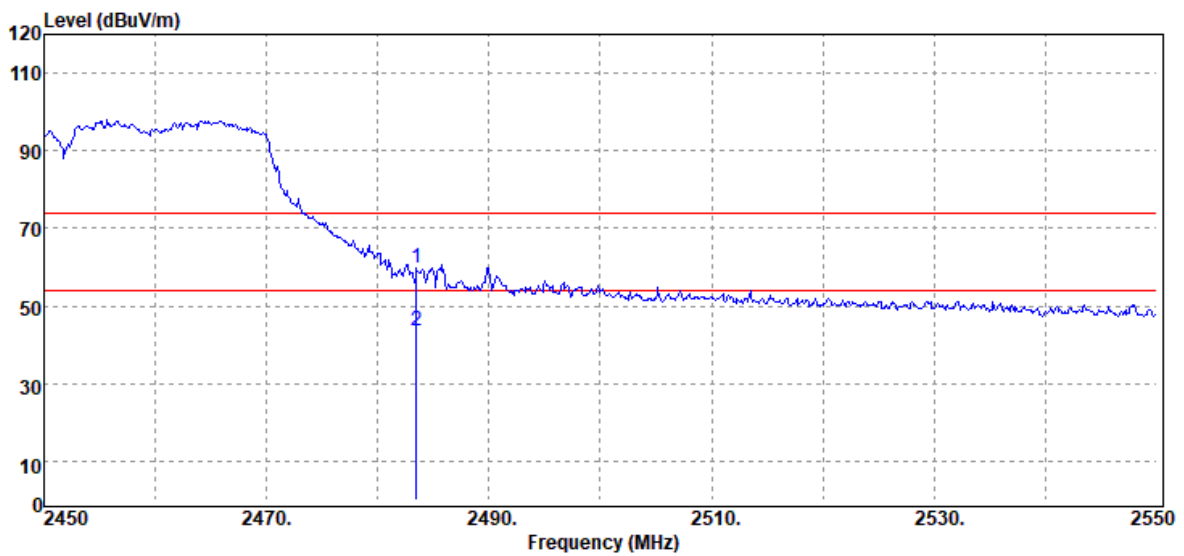

Frequency (MHz)	Detector Mode (PK/QP/AV)	Spectrum Reading Level (dB μ V)	Factor (dB)	Actual FS (dB μ V/m)	Limit @3m (dB μ V/m)	Margin (dB)
2483.50	Peak	60.45	-0.66	59.79	74.00	-14.21
2483.50	Average	44.31	-0.66	43.65	54.00	-10.35

Test Mode	IEEE 802.11n40 High CH 2452MHz	Temp/Hum	22.4(°C)/ 62%RH
Test Item	Band Edge	Test Date	April 16, 2021
Polarize	Horizontal	Test Engineer	Ray Li
Detector	Peak / Average		

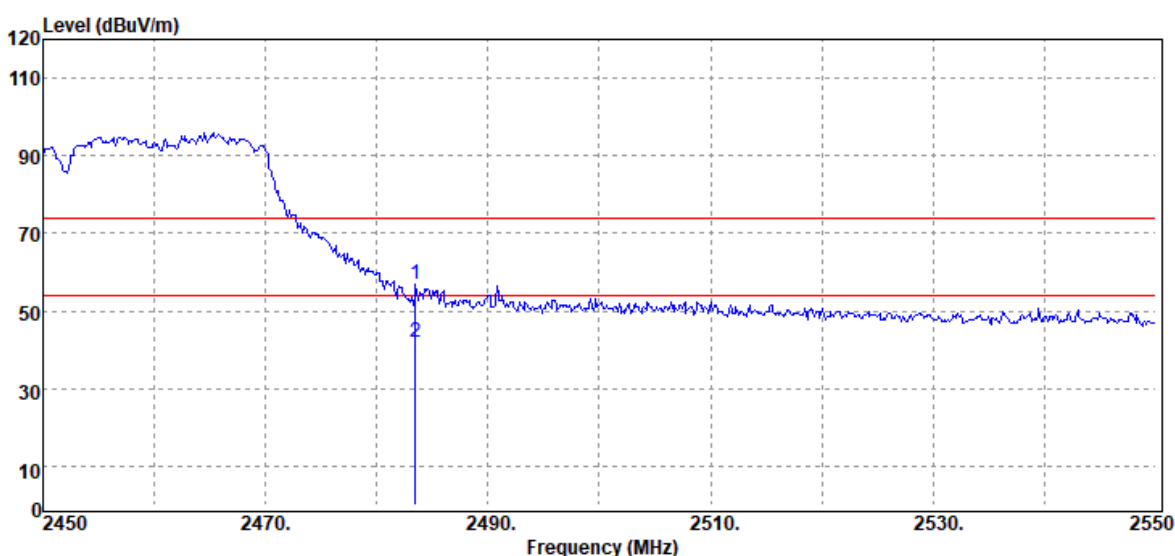

Frequency (MHz)	Detector Mode (PK/QP/AV)	Spectrum Reading Level (dBμV)	Factor (dB)	Actual FS (dBμV/m)	Limit @3m (dBμV/m)	Margin (dB)
2483.50	Peak	57.43	-0.66	56.77	74.00	-17.23
2483.50	Average	42.43	-0.66	41.77	54.00	-12.23

Below 1G Test Data

Test Mode	Mode 1	Temp/Hum	22.4(°C)/ 62%RH
Test Item	30MHz-1GHz	Test Date	April 15, 2021
Polarize	Vertical	Test Engineer	Ray Li
Detector	Peak	Test Voltage	

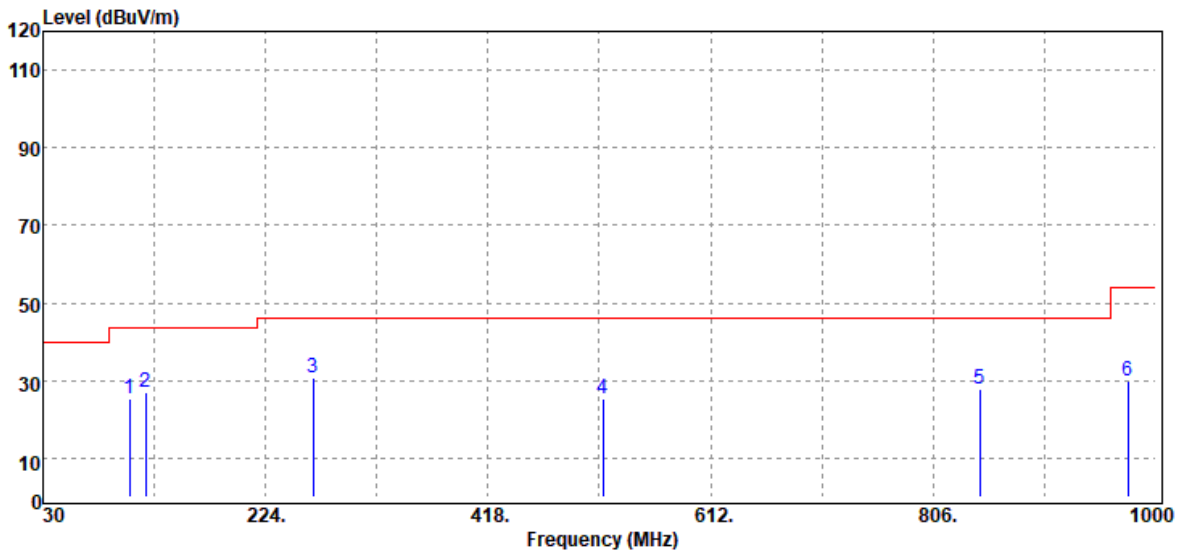

Freq. (MHz)	Detector Mode (PK/QP/AV)	Spectrum Reading Level (dBμV)	Factor (dB)	Actual FS (dBμV/m)	Limit @3m (dBμV/m)	Margin (dB)
105.66	Peak	36.55	-11.23	25.32	43.50	-18.18
119.24	Peak	36.07	-9.23	26.84	43.50	-16.66
265.71	Peak	39.95	-9.33	30.62	46.00	-15.38
517.91	Peak	28.36	-3.11	25.25	46.00	-20.75
846.74	Peak	25.42	2.47	27.89	46.00	-18.11
975.75	Peak	25.79	4.21	30.00	54.00	-24.00

Note: No emission found between lowest internal used/generated frequency to 30MHz(9KHz~30MHz)

Test Mode	Mode 1	Temp/Hum	22.4(°C)/ 62%RH
Test Item	30MHz-1GHz	Test Date	April 15, 2021
Polarize	Horizontal	Test Engineer	Ray Li
Detector	Peak	Test Voltage	

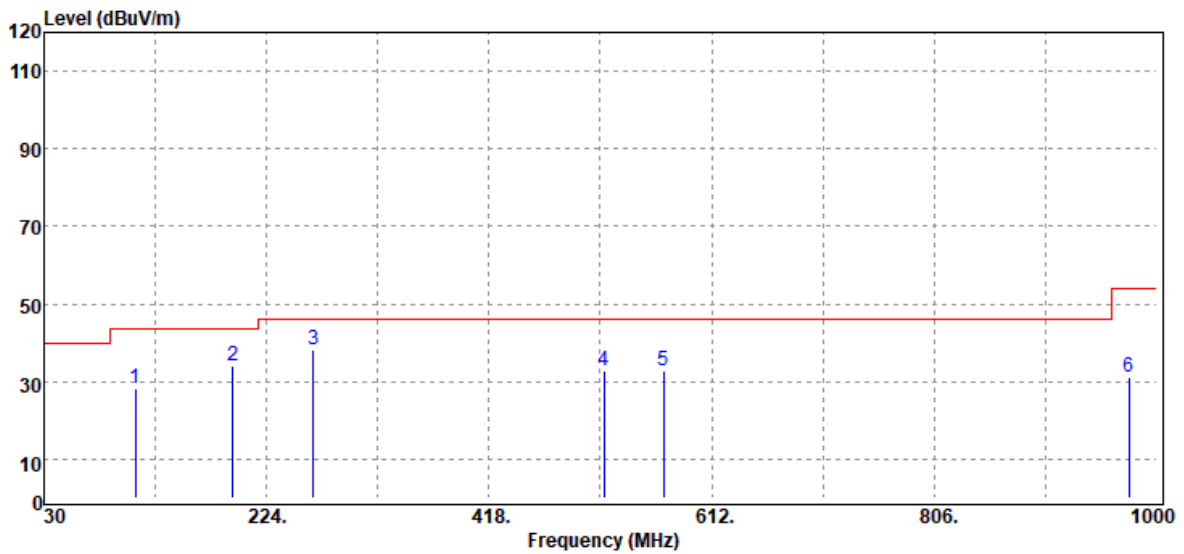

Freq. (MHz)	Detector Mode (PK/QP/AV)	Spectrum Reading Level (dBμV)	Factor (dB)	Actual FS (dBμV/m)	Limit @3m (dBμV/m)	Margin (dB)
109.54	Peak	38.65	-10.52	28.13	43.50	-15.37
194.90	Peak	44.39	-10.21	34.18	43.50	-9.32
264.74	Peak	47.70	-9.43	38.27	46.00	-7.73
517.91	Peak	35.81	-3.11	32.70	46.00	-13.30
570.29	Peak	34.95	-2.05	32.90	46.00	-13.10
975.75	Peak	26.76	4.21	30.97	54.00	-23.03

Note: No emission found between lowest internal used/generated frequency to 30MHz(9KHz~30MHz)

Report No.: T210113D03-RP3

Above 1G Test Data

Test Mode	IEEE 802.11b Low CH	Temp/Hum	22.4(°C)/ 62%RH
Test Item	Harmonic	Test Date	April 16, 2021
Polarize	Vertical	Test Engineer	Ray Li
Detector	Peak		

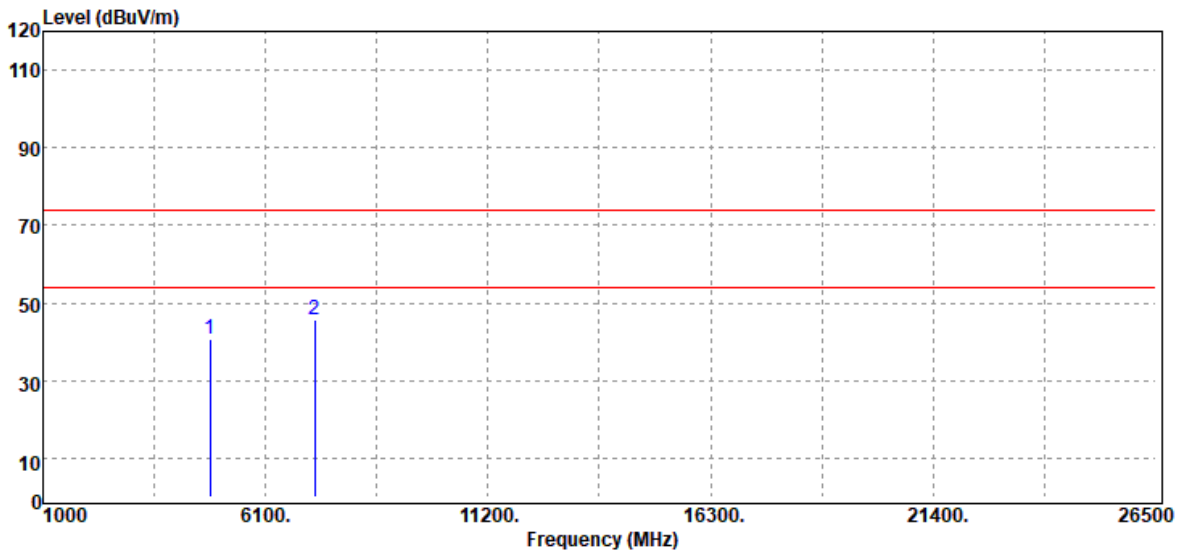

Freq. (MHz)	Detector Mode (PK/QP/AV)	Spectrum Reading Level (dBμV)	Factor (dB)	Actual FS (dBμV/m)	Limit @3m (dBμV/m)	Margin (dB)
4824.00	Peak	34.99	5.68	40.67	74.00	-33.33
7236.00	Peak	32.36	13.17	45.53	74.00	-28.47
N/A						

Remark:

1. Measuring frequencies from 1 GHz to the 10th harmonic of highest fundamental frequency.
2. For above 1GHz, the EUT peak value was under average limit, therefore the Average value compliance with the average limit

Report No.: T210113D03-RP3

Test Mode	IEEE 802.11b Low CH	Temp/Hum	22.4(°C)/ 62%RH
Test Item	Harmonic	Test Date	April 16, 2021
Polarize	Horizontal	Test Engineer	Ray Li
Detector	Peak		

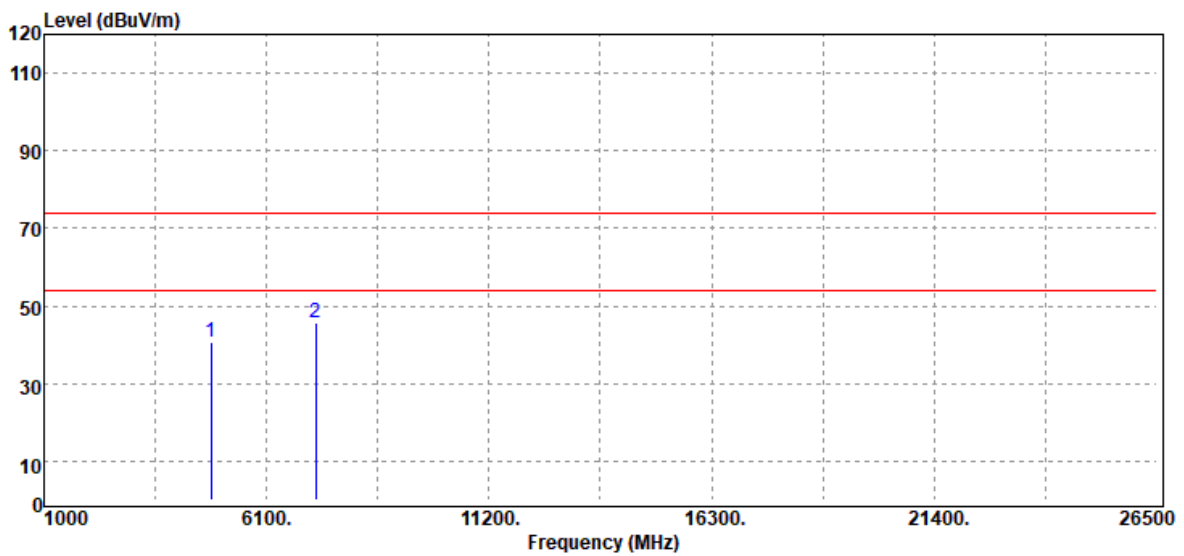

Freq. (MHz)	Detector Mode (PK/QP/AV)	Spectrum Reading Level (dB μ V)	Factor (dB)	Actual FS (dB μ V/m)	Limit @3m (dB μ V/m)	Margin (dB)
4824.00	Peak	35.11	5.68	40.79	74.00	-33.21
7236.00	Peak	32.33	13.17	45.50	74.00	-28.50
N/A						

Remark:

1. Measuring frequencies from 1 GHz to the 10th harmonic of highest fundamental frequency.
2. For above 1GHz, the EUT peak value was under average limit, therefore the Average value compliance with the average limit

Report No.: T210113D03-RP3

Test Mode	IEEE 802.11b Mid CH	Temp/Hum	22.4(°C)/ 62%RH
Test Item	Harmonic	Test Date	April 16, 2021
Polarize	Vertical	Test Engineer	Ray Li
Detector	Peak		

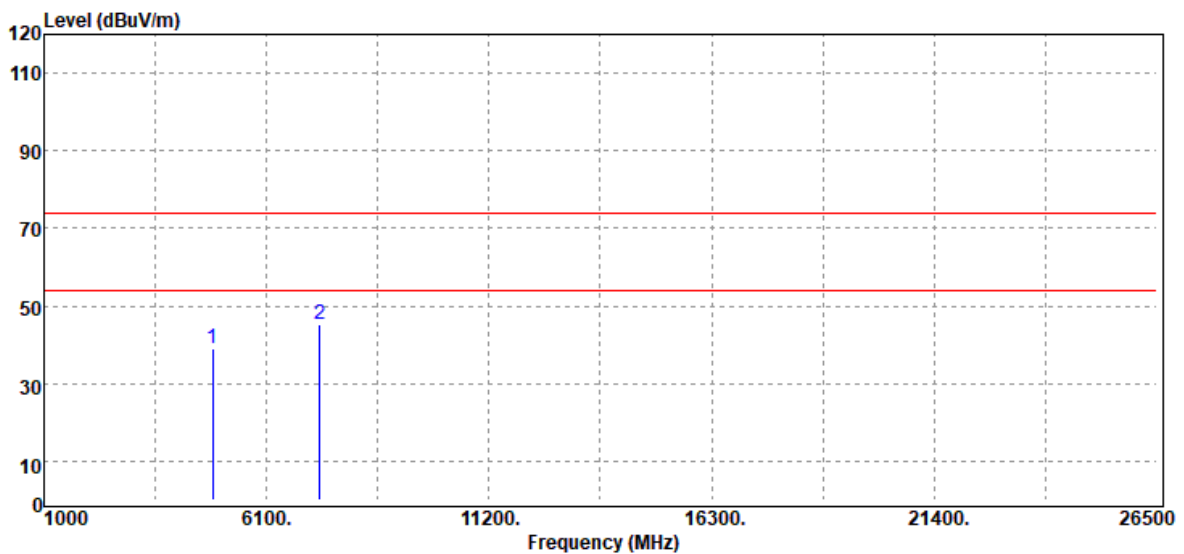

Freq. (MHz)	Detector Mode (PK/QP/AV)	Spectrum Reading Level (dB μ V)	Factor (dB)	Actual FS (dB μ V/m)	Limit @3m (dB μ V/m)	Margin (dB)
4874.00	Peak	33.31	5.92	39.23	74.00	-34.77
7311.00	Peak	31.97	13.26	45.23	74.00	-28.77
N/A						

Remark:

1. Measuring frequencies from 1 GHz to the 10th harmonic of highest fundamental frequency.
2. For above 1GHz,the EUT peak value was under average limit, therefore the Average value compliance with the average limit

Report No.: T210113D03-RP3

Test Mode	IEEE 802.11b Mid CH	Temp/Hum	22.4(°C)/ 62%RH
Test Item	Harmonic	Test Date	April 16, 2021
Polarize	Horizontal	Test Engineer	Ray Li
Detector	Peak		

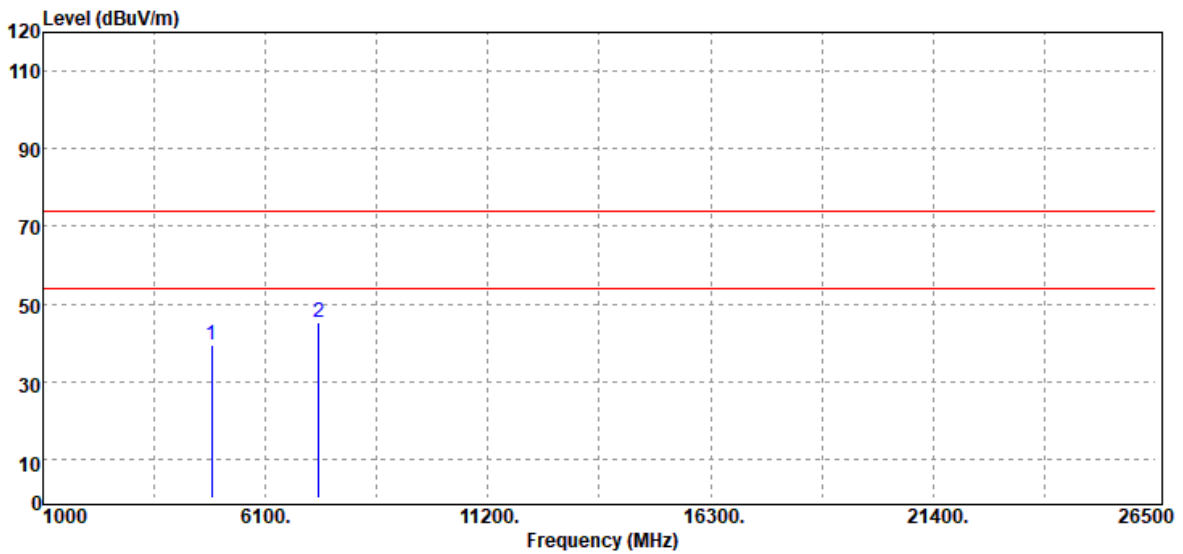

Freq. (MHz)	Detector Mode (PK/QP/AV)	Spectrum Reading Level (dBμV)	Factor (dB)	Actual FS (dBμV/m)	Limit @3m (dBμV/m)	Margin (dB)
4874.00	Peak	33.38	5.92	39.30	74.00	-34.70
7311.00	Peak	32.17	13.26	45.43	74.00	-28.57
N/A						

Remark:

1. Measuring frequencies from 1 GHz to the 10th harmonic of highest fundamental frequency.
2. For above 1GHz,the EUT peak value was under average limit, therefore the Average value compliance with the average limit

Test Mode	IEEE 802.11b High CH	Temp/Hum	22.4(°C)/ 62%RH
Test Item	Harmonic	Test Date	April 16, 2021
Polarize	Vertical	Test Engineer	Ray Li
Detector	Peak		

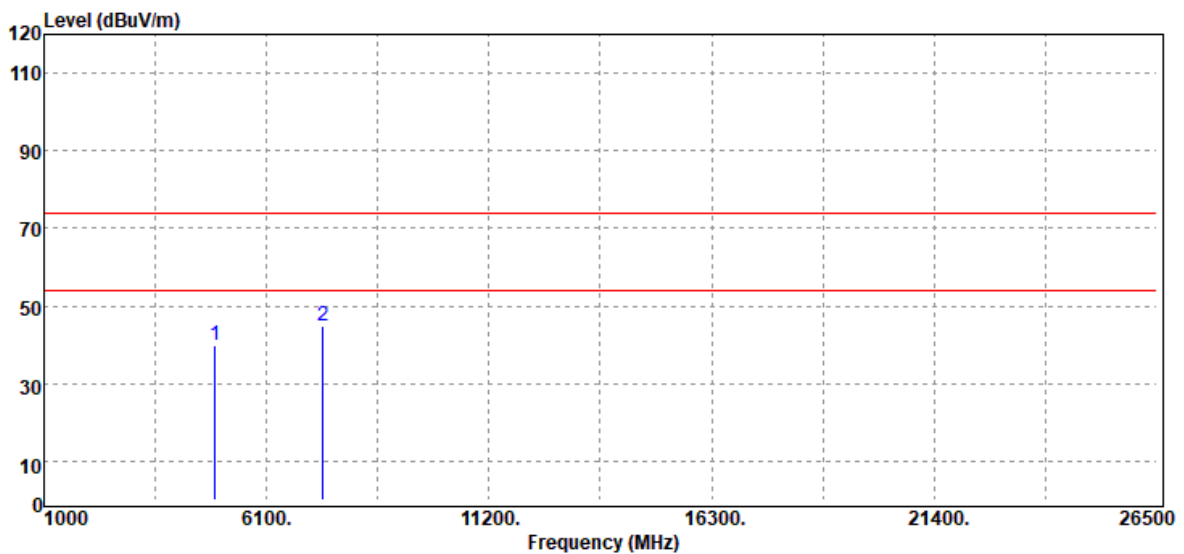

Freq. (MHz)	Detector Mode (PK/QP/AV)	Spectrum Reading Level (dBμV)	Factor (dB)	Actual FS (dBμV/m)	Limit @3m (dBμV/m)	Margin (dB)
4924.00	Peak	33.57	6.37	39.94	74.00	-34.06
7386.00	Peak	31.93	13.07	45.00	74.00	-29.00
N/A						

Remark:

1. Measuring frequencies from 1 GHz to the 10th harmonic of highest fundamental frequency.
2. For above 1GHz, the EUT peak value was under average limit, therefore the Average value compliance with the average limit

Report No.: T210113D03-RP3

Test Mode	IEEE 802.11b High CH	Temp/Hum	22.4(°C)/ 62%RH
Test Item	Harmonic	Test Date	April 16, 2021
Polarize	Horizontal	Test Engineer	Ray Li
Detector	Peak		

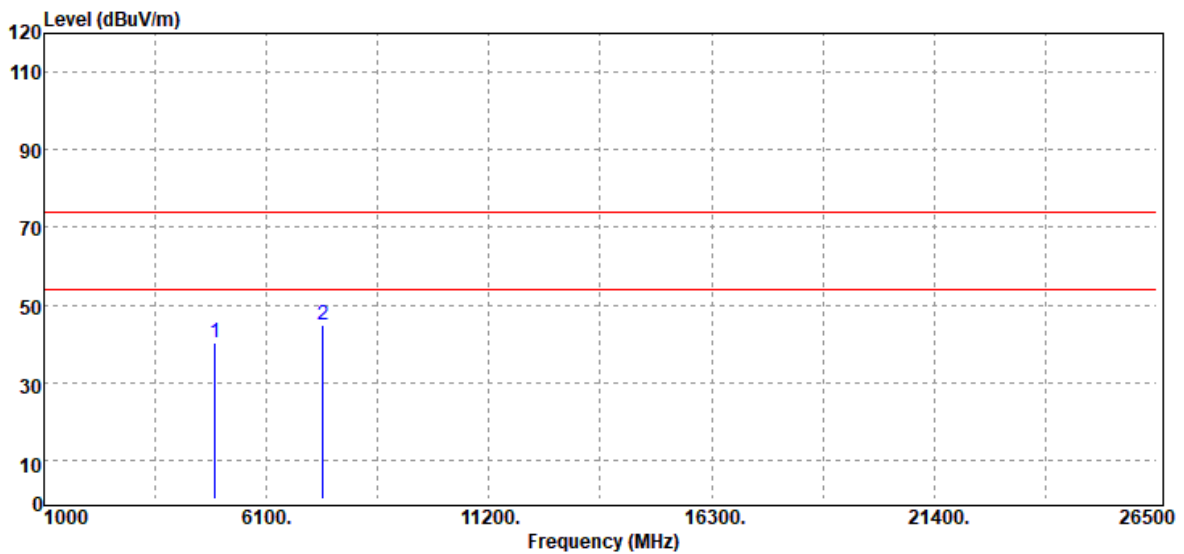

Freq. (MHz)	Detector Mode (PK/QP/AV)	Spectrum Reading Level (dB μ V)	Factor (dB)	Actual FS (dB μ V/m)	Limit @3m (dB μ V/m)	Margin (dB)
4924.00	Peak	33.93	6.37	40.30	74.00	-33.70
7386.00	Peak	31.67	13.07	44.74	74.00	-29.26
N/A						

Remark:

1. Measuring frequencies from 1 GHz to the 10th harmonic of highest fundamental frequency.
2. For above 1GHz,the EUT peak value was under average limit, therefore the Average value compliance with the average limit

Report No.: T210113D03-RP3

Test Mode	IEEE 802.11g Low CH	Temp/Hum	22.4(°C)/ 62%RH
Test Item	Harmonic	Test Date	April 16, 2021
Polarize	Vertical	Test Engineer	Ray Li
Detector	Peak		

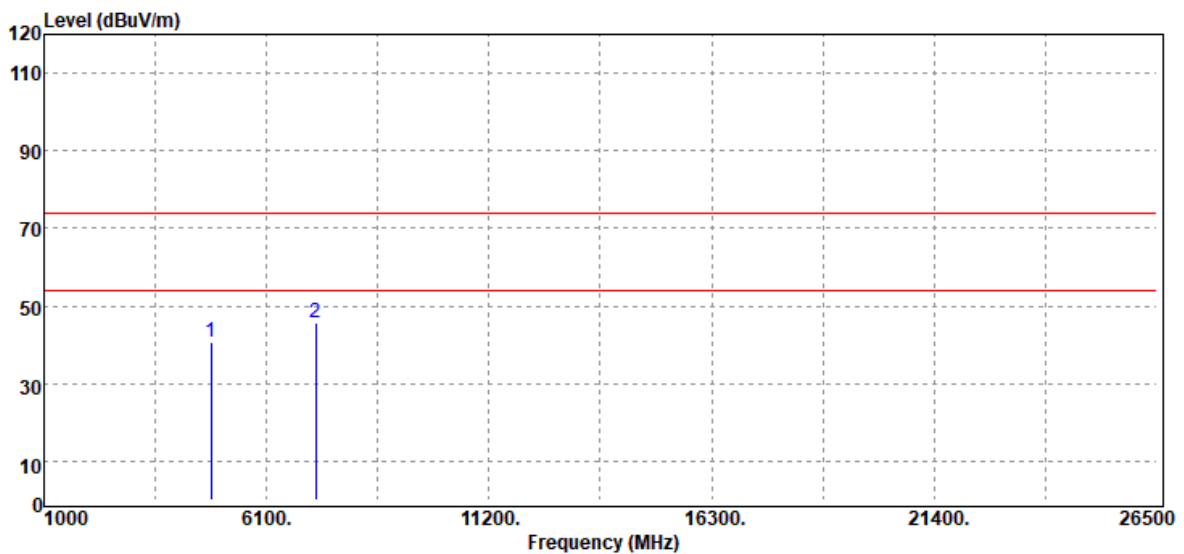

Freq. (MHz)	Detector Mode (PK/QP/AV)	Spectrum Reading Level (dBμV)	Factor (dB)	Actual FS (dBμV/m)	Limit @3m (dBμV/m)	Margin (dB)
4824.00	Peak	35.03	5.68	40.71	74.00	-33.29
7236.00	Peak	32.50	13.17	45.67	74.00	-28.33
N/A						

Remark:

1. Measuring frequencies from 1 GHz to the 10th harmonic of highest fundamental frequency.
2. For above 1GHz,the EUT peak value was under average limit, therefore the Average value compliance with the average limit

Report No.: T210113D03-RP3

Test Mode	IEEE 802.11g Low CH	Temp/Hum	22.4(°C)/ 62%RH
Test Item	Harmonic	Test Date	April 16, 2021
Polarize	Horizontal	Test Engineer	Ray Li
Detector	Peak		

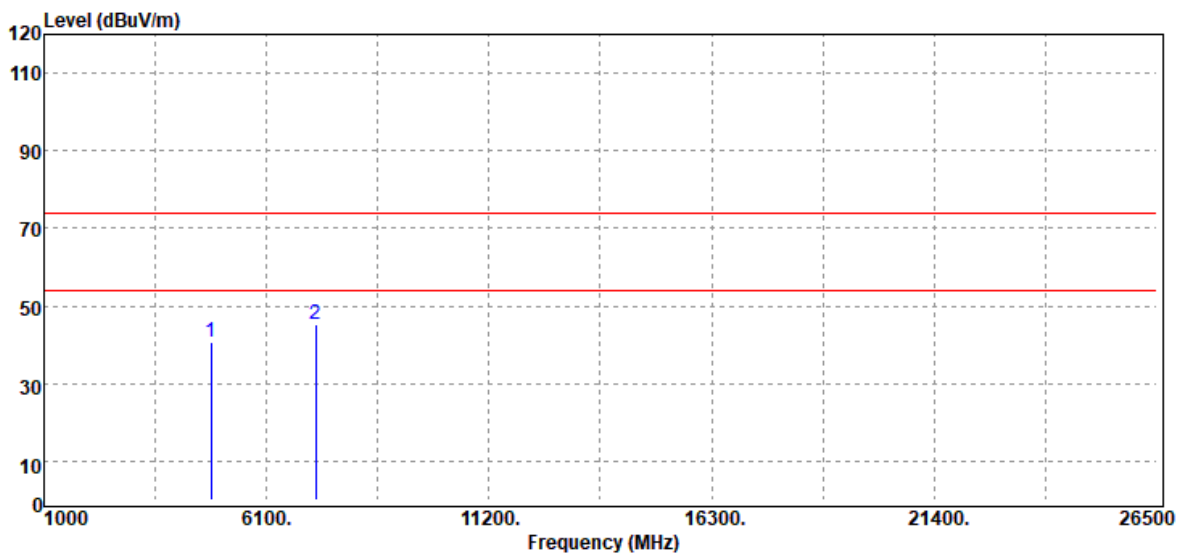

Freq. (MHz)	Detector Mode (PK/QP/AV)	Spectrum Reading Level (dBμV)	Factor (dB)	Actual FS (dBμV/m)	Limit @3m (dBμV/m)	Margin (dB)
4824.00	Peak	35.10	5.68	40.78	74.00	-33.22
7236.00	Peak	31.95	13.17	45.12	74.00	-28.88
N/A						

Remark:

1. Measuring frequencies from 1 GHz to the 10th harmonic of highest fundamental frequency.
2. For above 1GHz,the EUT peak value was under average limit, therefore the Average value compliance with the average limit

Report No.: T210113D03-RP3

Test Mode	IEEE 802.11g Mid CH	Temp/Hum	22.4(°C)/ 62%RH
Test Item	Harmonic	Test Date	April 16, 2021
Polarize	Vertical	Test Engineer	Ray Li
Detector	Peak		

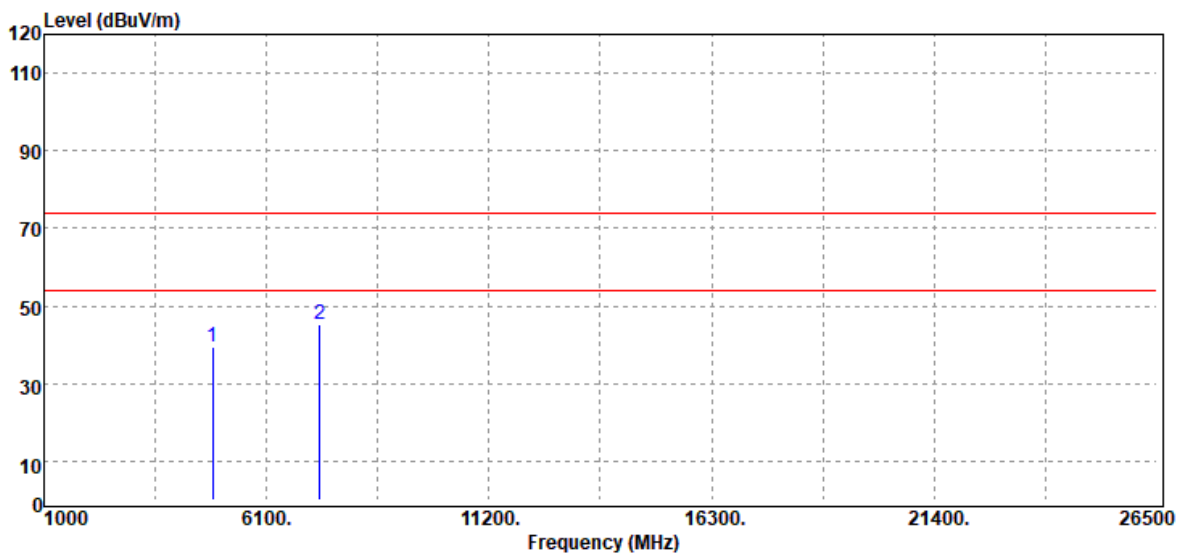

Freq. (MHz)	Detector Mode (PK/QP/AV)	Spectrum Reading Level (dBμV)	Factor (dB)	Actual FS (dBμV/m)	Limit @3m (dBμV/m)	Margin (dB)
4874.00	Peak	33.44	5.92	39.36	74.00	-34.64
7311.00	Peak	31.86	13.26	45.12	74.00	-28.88
N/A						

Remark:

1. Measuring frequencies from 1 GHz to the 10th harmonic of highest fundamental frequency.
2. For above 1GHz,the EUT peak value was under average limit, therefore the Average value compliance with the average limit

Report No.: T210113D03-RP3

Test Mode	IEEE 802.11g Mid CH	Temp/Hum	22.4(°C)/ 62%RH
Test Item	Harmonic	Test Date	April 16, 2021
Polarize	Horizontal	Test Engineer	Ray Li
Detector	Peak		

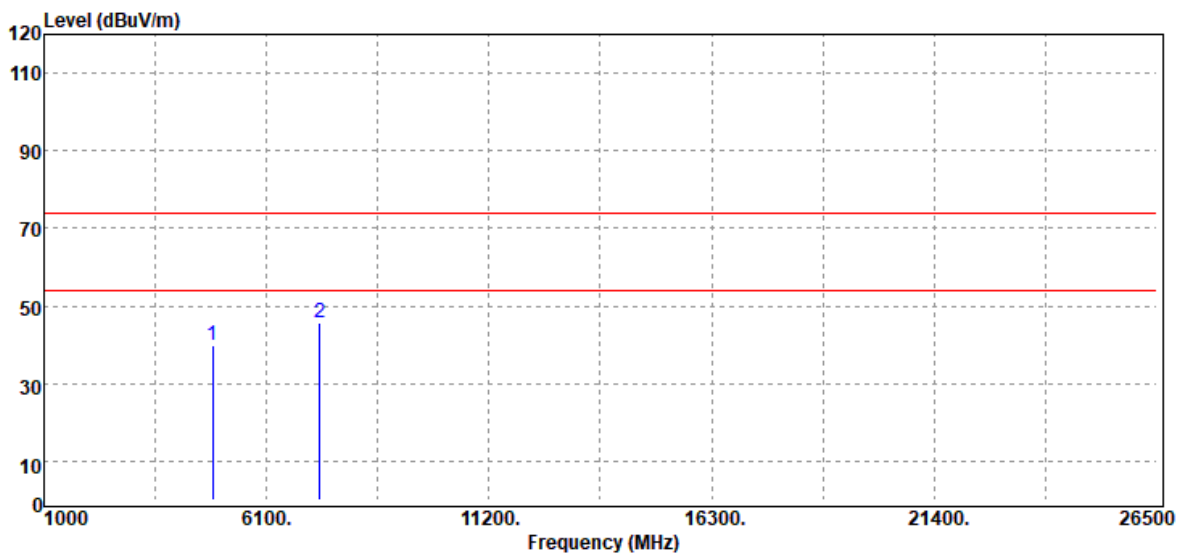

Freq. (MHz)	Detector Mode (PK/QP/AV)	Spectrum Reading Level (dB μ V)	Factor (dB)	Actual FS (dB μ V/m)	Limit @3m (dB μ V/m)	Margin (dB)
4874.00	Peak	34.04	5.92	39.96	74.00	-34.04
7311.00	Peak	32.38	13.26	45.64	74.00	-28.36
N/A						

Remark:

1. Measuring frequencies from 1 GHz to the 10th harmonic of highest fundamental frequency.
2. For above 1GHz,the EUT peak value was under average limit, therefore the Average value compliance with the average limit

Report No.: T210113D03-RP3

Test Mode	IEEE 802.11g High CH	Temp/Hum	22.4(°C)/ 62%RH
Test Item	Harmonic	Test Date	April 16, 2021
Polarize	Vertical	Test Engineer	Ray Li
Detector	Peak		

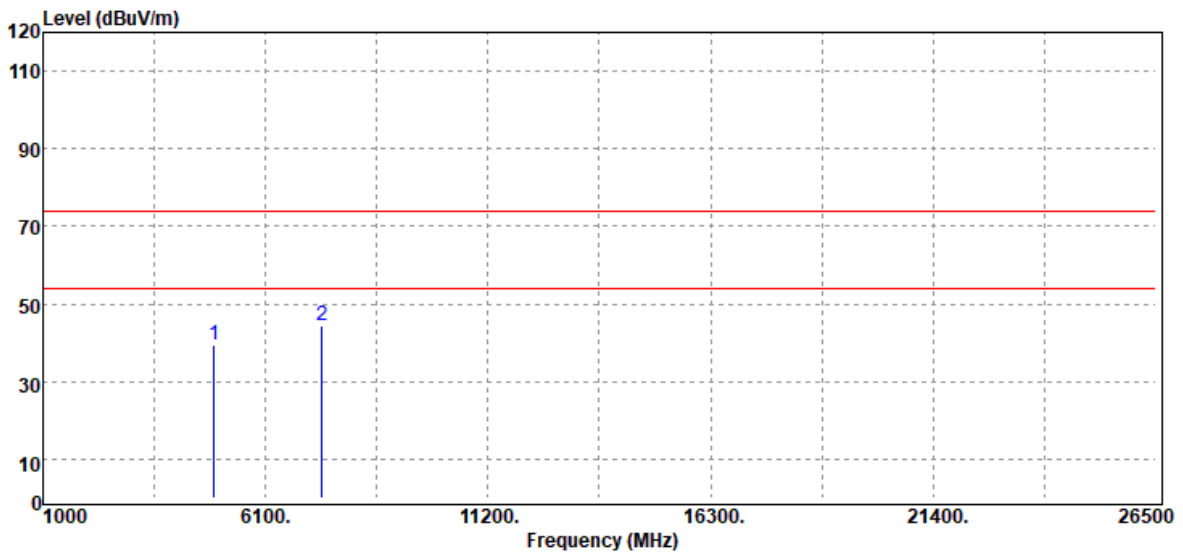

Freq. (MHz)	Detector Mode (PK/QP/AV)	Spectrum Reading Level (dB μ V)	Factor (dB)	Actual FS (dB μ V/m)	Limit @3m (dB μ V/m)	Margin (dB)
4924.00	Peak	32.98	6.37	39.35	74.00	-34.65
7386.00	Peak	31.26	13.07	44.33	74.00	-29.67
N/A						

Remark:

1. Measuring frequencies from 1 GHz to the 10th harmonic of highest fundamental frequency.
2. For above 1GHz,the EUT peak value was under average limit, therefore the Average value compliance with the average limit

Report No.: T210113D03-RP3

Test Mode	IEEE 802.11g High CH	Temp/Hum	22.4(°C)/ 62%RH
Test Item	Harmonic	Test Date	April 16, 2021
Polarize	Horizontal	Test Engineer	Ray Li
Detector	Peak		

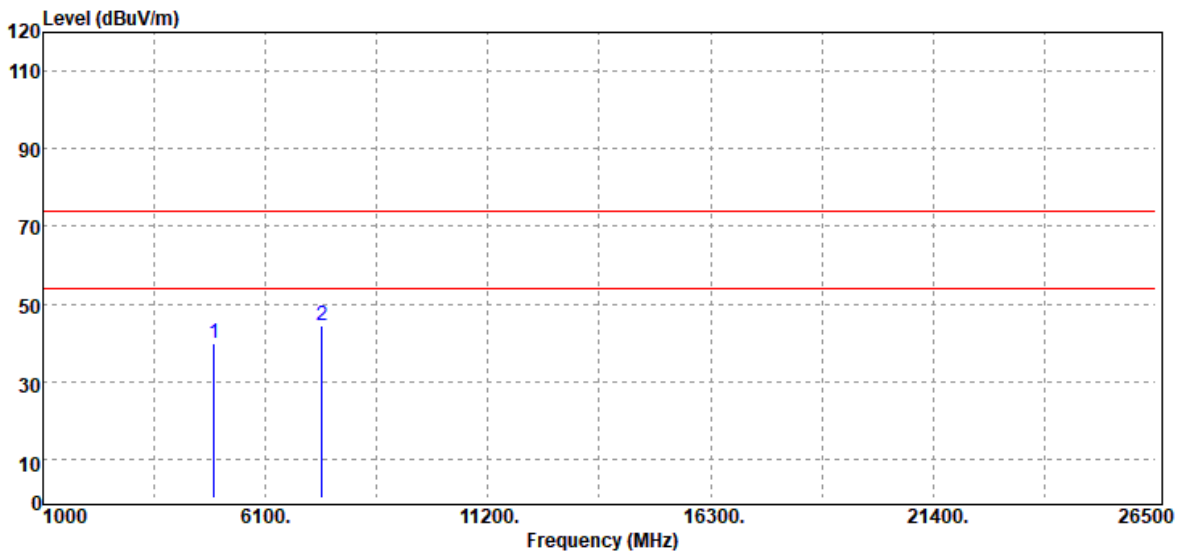

Freq. (MHz)	Detector Mode (PK/QP/AV)	Spectrum Reading Level (dBμV)	Factor (dB)	Actual FS (dBμV/m)	Limit @3m (dBμV/m)	Margin (dB)
4924.00	Peak	33.53	6.37	39.90	74.00	-34.10
7386.00	Peak	31.32	13.07	44.39	74.00	-29.61
N/A						

Remark:

1. Measuring frequencies from 1 GHz to the 10th harmonic of highest fundamental frequency.
2. For above 1GHz,the EUT peak value was under average limit, therefore the Average value compliance with the average limit

Report No.: T210113D03-RP3

Test Mode	IEEE 802.11n HT20 Low CH	Temp/Hum	22.4(°C)/ 62%RH
Test Item	Harmonic	Test Date	April 16, 2021
Polarize	Vertical	Test Engineer	Ray Li
Detector	Peak		

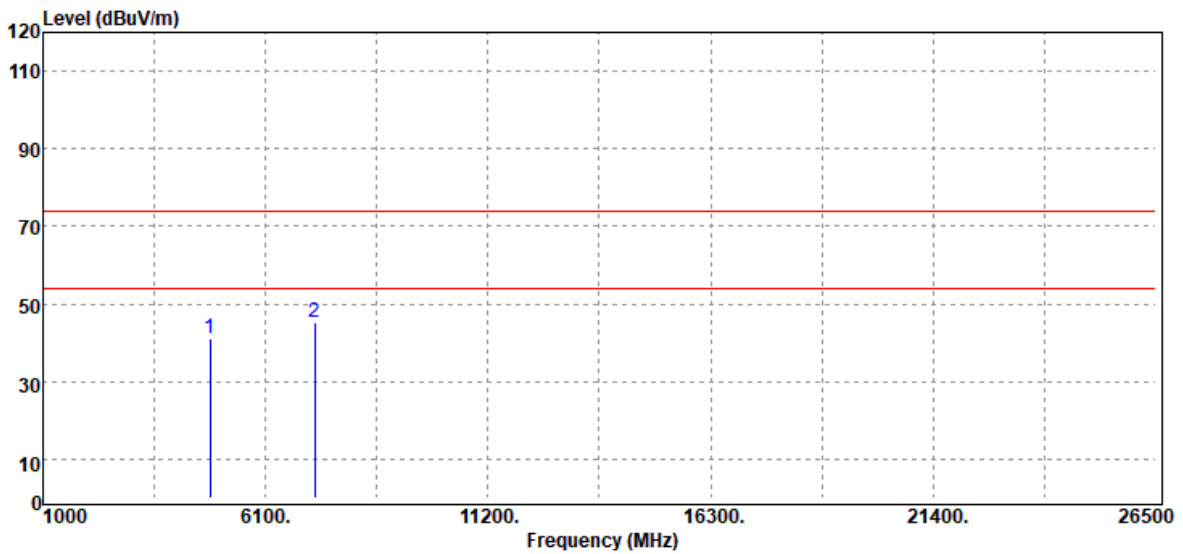

Freq. (MHz)	Detector Mode (PK/QP/AV)	Spectrum Reading Level (dBμV)	Factor (dB)	Actual FS (dBμV/m)	Limit @3m (dBμV/m)	Margin (dB)
4824.00	Peak	35.28	5.68	40.96	74.00	-33.04
7236.00	Peak	32.05	13.17	45.22	74.00	-28.78
N/A						

Remark:

1. Measuring frequencies from 1 GHz to the 10th harmonic of highest fundamental frequency.
2. For above 1GHz, the EUT peak value was under average limit, therefore the Average value compliance with the average limit

Test Mode	IEEE 802.11n HT20 Low CH	Temp/Hum	22.4(°C)/ 62%RH
Test Item	Harmonic	Test Date	April 16, 2021
Polarize	Horizontal	Test Engineer	Ray Li
Detector	Peak		

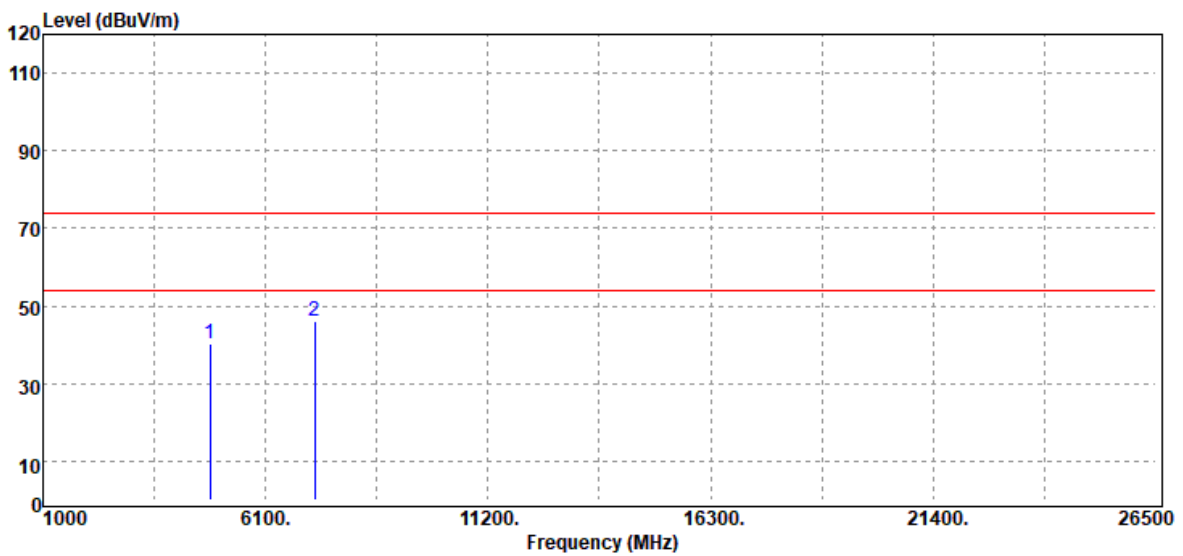

Freq. (MHz)	Detector Mode (PK/QP/AV)	Spectrum Reading Level (dB μ V)	Factor (dB)	Actual FS (dB μ V/m)	Limit @3m (dB μ V/m)	Margin (dB)
4824.00	Peak	34.65	5.68	40.33	74.00	-33.67
7236.00	Peak	32.76	13.17	45.93	74.00	-28.07
N/A						

Remark:

1. Measuring frequencies from 1 GHz to the 10th harmonic of highest fundamental frequency.
2. For above 1GHz, the EUT peak value was under average limit, therefore the Average value compliance with the average limit

Report No.: T210113D03-RP3

Test Mode	IEEE 802.11n HT20 Mid CH	Temp/Hum	22.4(°C)/ 62%RH
Test Item	Harmonic	Test Date	April 16, 2021
Polarize	Vertical	Test Engineer	Ray Li
Detector	Peak		

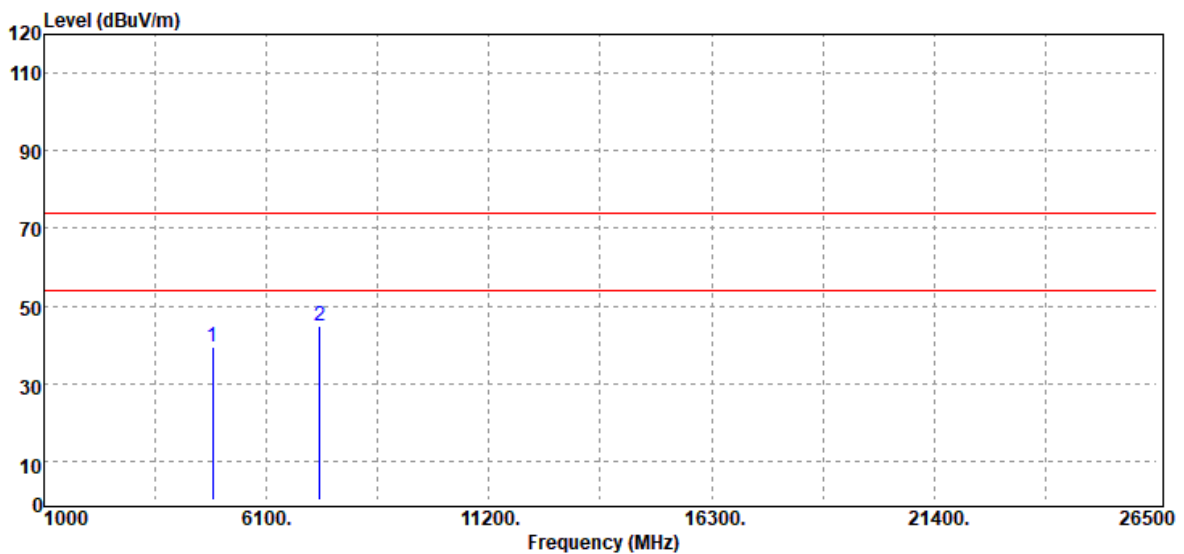

Freq. (MHz)	Detector Mode (PK/QP/AV)	Spectrum Reading Level (dBμV)	Factor (dB)	Actual FS (dBμV/m)	Limit @3m (dBμV/m)	Margin (dB)
4874.00	Peak	33.41	5.92	39.33	74.00	-34.67
7311.00	Peak	31.65	13.26	44.91	74.00	-29.09
N/A						

Remark:

1. Measuring frequencies from 1 GHz to the 10th harmonic of highest fundamental frequency.
2. For above 1GHz,the EUT peak value was under average limit, therefore the Average value compliance with the average limit

Report No.: T210113D03-RP3

Test Mode	IEEE 802.11n HT20 Mid CH	Temp/Hum	22.4(°C)/ 62%RH
Test Item	Harmonic	Test Date	April 16, 2021
Polarize	Horizontal	Test Engineer	Ray Li
Detector	Peak		

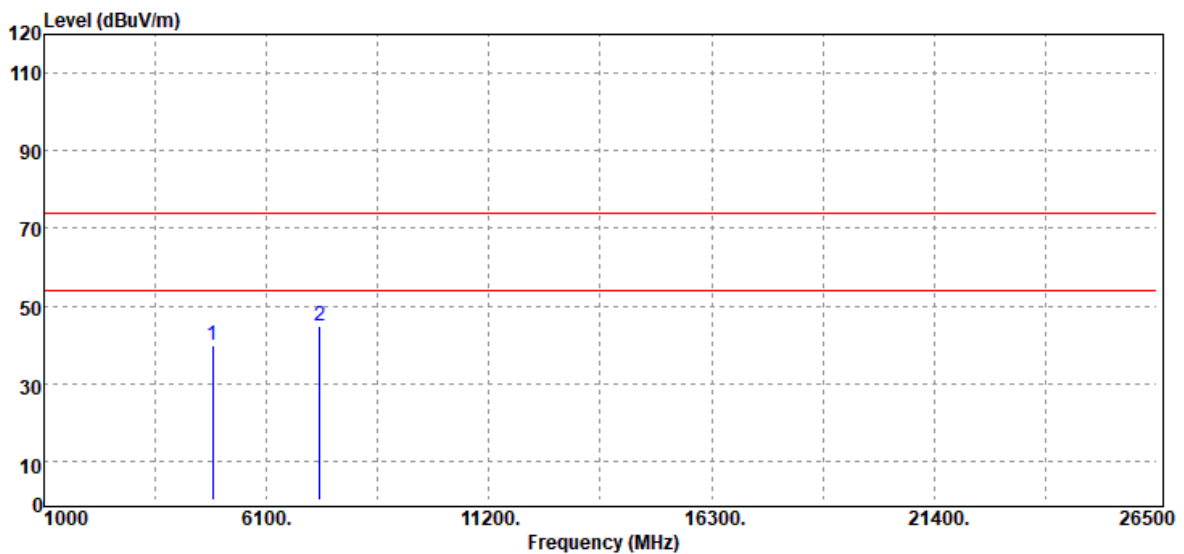

Freq. (MHz)	Detector Mode (PK/QP/AV)	Spectrum Reading Level (dBμV)	Factor (dB)	Actual FS (dBμV/m)	Limit @3m (dBμV/m)	Margin (dB)
4874.00	Peak	33.87	5.92	39.79	74.00	-34.21
7311.00	Peak	31.73	13.26	44.99	74.00	-29.01
N/A						

Remark:

1. Measuring frequencies from 1 GHz to the 10th harmonic of highest fundamental frequency.
2. For above 1GHz, the EUT peak value was under average limit, therefore the Average value compliance with the average limit

Report No.: T210113D03-RP3

Test Mode	IEEE 802.11n HT20 High CH	Temp/Hum	22.4(°C)/ 62%RH
Test Item	Harmonic	Test Date	April 16, 2021
Polarize	Vertical	Test Engineer	Ray Li
Detector	Peak		

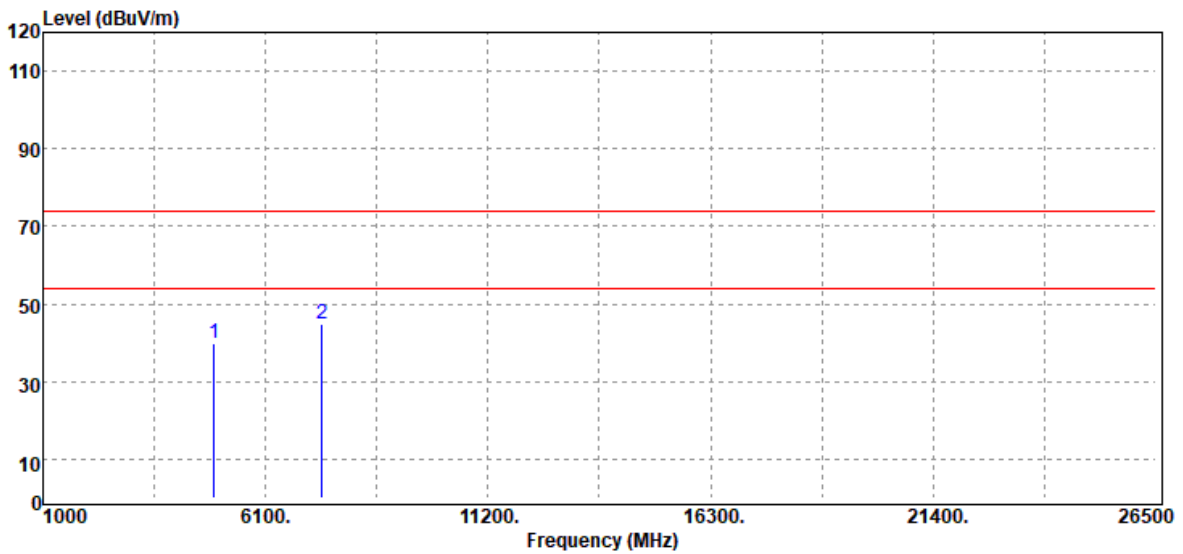

Freq. (MHz)	Detector Mode (PK/QP/AV)	Spectrum Reading Level (dBμV)	Factor (dB)	Actual FS (dBμV/m)	Limit @3m (dBμV/m)	Margin (dB)
4924.00	Peak	33.51	6.37	39.88	74.00	-34.12
7386.00	Peak	31.82	13.07	44.89	74.00	-29.11
N/A						

Remark:

1. Measuring frequencies from 1 GHz to the 10th harmonic of highest fundamental frequency.
2. For above 1GHz,the EUT peak value was under average limit, therefore the Average value compliance with the average limit

Report No.: T210113D03-RP3

Test Mode	IEEE 802.11n HT20 High CH	Temp/Hum	22.4(°C)/ 62%RH
Test Item	Harmonic	Test Date	April 16, 2021
Polarize	Horizontal	Test Engineer	Ray Li
Detector	Peak		

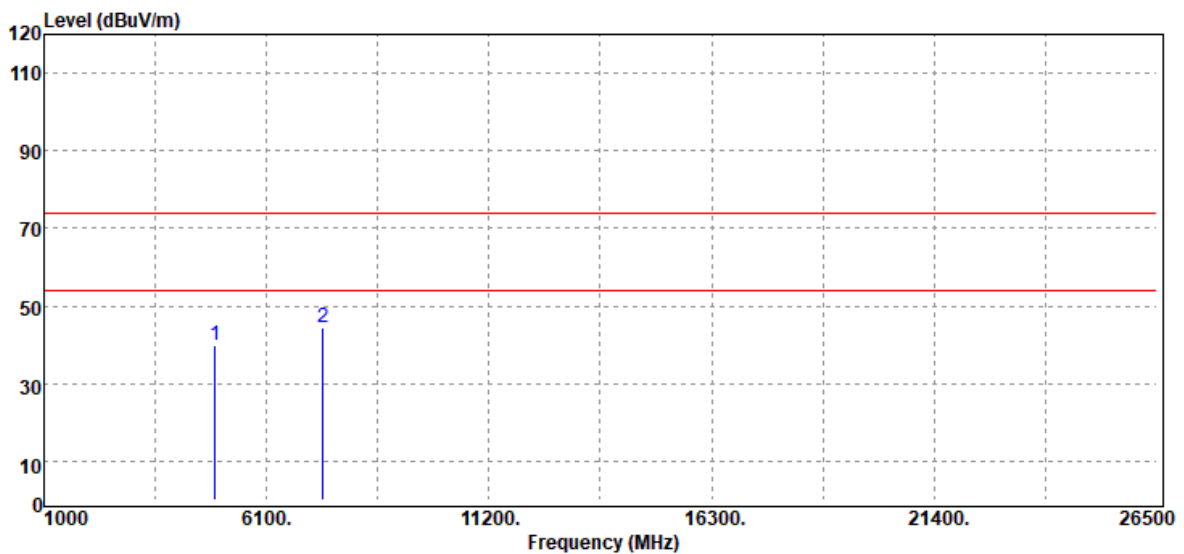

Freq. (MHz)	Detector Mode (PK/QP/AV)	Spectrum Reading Level (dBμV)	Factor (dB)	Actual FS (dBμV/m)	Limit @3m (dBμV/m)	Margin (dB)
4924.00	Peak	33.45	6.37	39.82	74.00	-34.18
7386.00	Peak	31.52	13.07	44.59	74.00	-29.41
N/A						

Remark:

1. Measuring frequencies from 1 GHz to the 10th harmonic of highest fundamental frequency.
2. For above 1GHz, the EUT peak value was under average limit, therefore the Average value compliance with the average limit

Report No.: T210113D03-RP3

Test Mode	IEEE 802.11n HT40 Low CH	Temp/Hum	22.4(°C)/ 62%RH
Test Item	Harmonic	Test Date	April 16, 2021
Polarize	Vertical	Test Engineer	Ray Li
Detector	Peak		

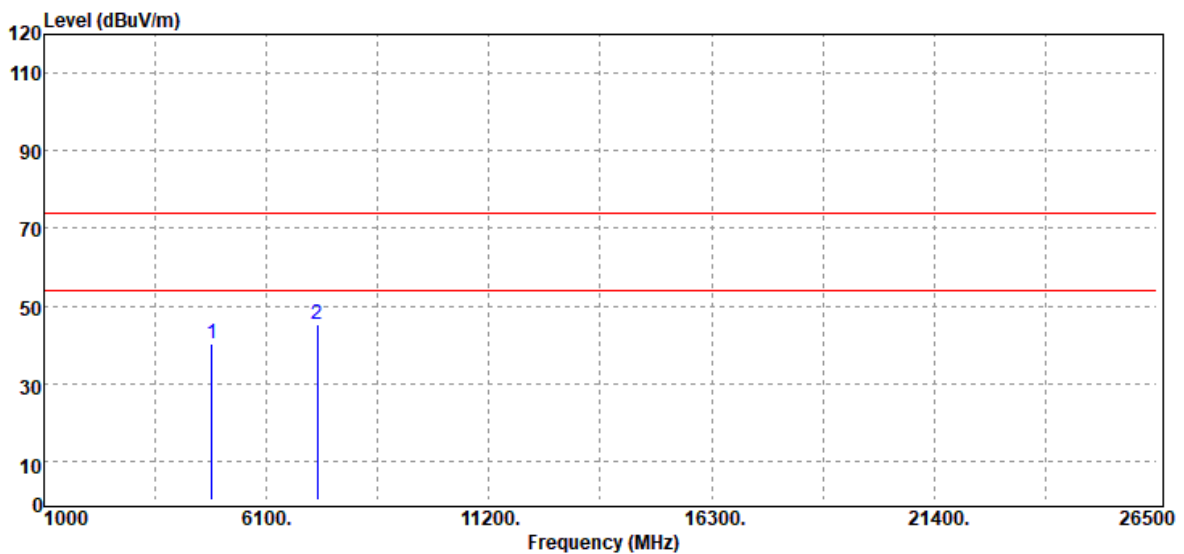

Freq. (MHz)	Detector Mode (PK/QP/AV)	Spectrum Reading Level (dBμV)	Factor (dB)	Actual FS (dBμV/m)	Limit @3m (dBμV/m)	Margin (dB)
4844.00	Peak	34.60	5.73	40.33	74.00	-33.67
7266.00	Peak	32.06	13.21	45.27	74.00	-28.73
N/A						

Remark:

1. Measuring frequencies from 1 GHz to the 10th harmonic of highest fundamental frequency.
2. For above 1GHz, the EUT peak value was under average limit, therefore the Average value compliance with the average limit

Report No.: T210113D03-RP3

Test Mode	IEEE 802.11n HT40 Low CH	Temp/Hum	22.4(°C)/ 62%RH
Test Item	Harmonic	Test Date	April 16, 2021
Polarize	Horizontal	Test Engineer	Ray Li
Detector	Peak		

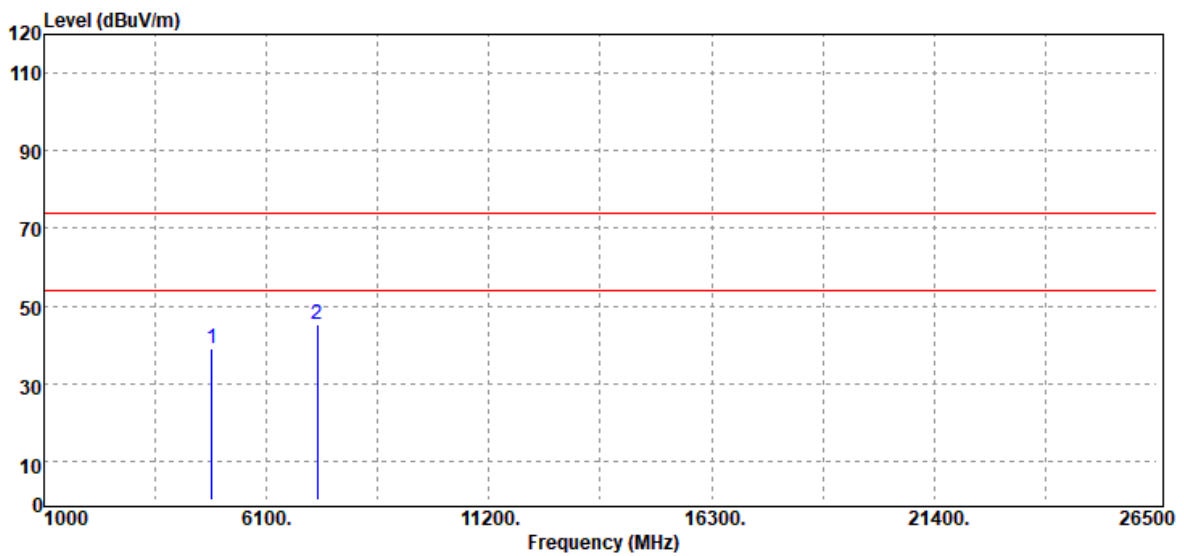

Freq. (MHz)	Detector Mode (PK/QP/AV)	Spectrum Reading Level (dB μ V)	Factor (dB)	Actual FS (dB μ V/m)	Limit @3m (dB μ V/m)	Margin (dB)
4844.00	Peak	33.49	5.73	39.22	74.00	-34.78
7266.00	Peak	32.04	13.21	45.25	74.00	-28.75
N/A						

Remark:

1. Measuring frequencies from 1 GHz to the 10th harmonic of highest fundamental frequency.
2. For above 1GHz, the EUT peak value was under average limit, therefore the Average value compliance with the average limit

Report No.: T210113D03-RP3

Test Mode	IEEE 802.11n HT40 Mid CH	Temp/Hum	22.4(°C)/ 62%RH
Test Item	Harmonic	Test Date	April 16, 2021
Polarize	Vertical	Test Engineer	Ray Li
Detector	Peak		

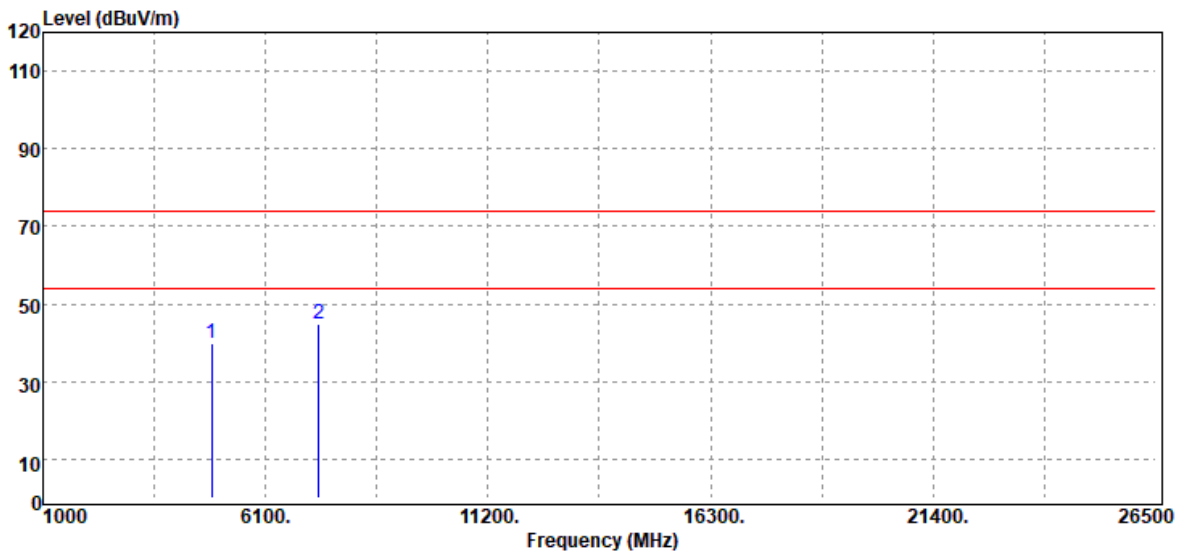

Freq. (MHz)	Detector Mode (PK/QP/AV)	Spectrum Reading Level (dBμV)	Factor (dB)	Actual FS (dBμV/m)	Limit @3m (dBμV/m)	Margin (dB)
4874.00	Peak	33.87	5.92	39.79	74.00	-34.21
7311.00	Peak	31.47	13.26	44.73	74.00	-29.27
N/A						

Remark:

1. Measuring frequencies from 1 GHz to the 10th harmonic of highest fundamental frequency.
2. For above 1GHz, the EUT peak value was under average limit, therefore the Average value compliance with the average limit

Report No.: T210113D03-RP3

Test Mode	IEEE 802.11n HT40 Mid CH	Temp/Hum	22.4(°C)/ 62%RH
Test Item	Harmonic	Test Date	April 16, 2021
Polarize	Horizontal	Test Engineer	Ray Li
Detector	Peak		

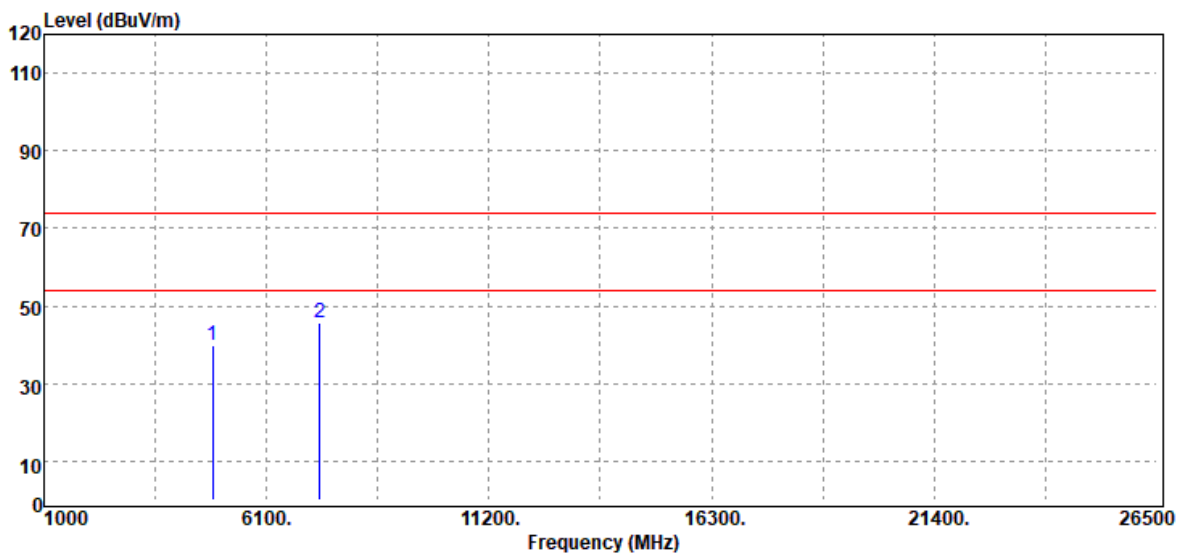

Freq. (MHz)	Detector Mode (PK/QP/AV)	Spectrum Reading Level (dBμV)	Factor (dB)	Actual FS (dBμV/m)	Limit @3m (dBμV/m)	Margin (dB)
4874.00	Peak	33.77	5.92	39.69	74.00	-34.31
7311.00	Peak	32.40	13.26	45.66	74.00	-28.34
N/A						

Remark:

1. Measuring frequencies from 1 GHz to the 10th harmonic of highest fundamental frequency.
2. For above 1GHz, the EUT peak value was under average limit, therefore the Average value compliance with the average limit

Report No.: T210113D03-RP3

Test Mode	IEEE 802.11n HT40 High CH	Temp/Hum	22.4(°C)/ 62%RH
Test Item	Harmonic	Test Date	April 16, 2021
Polarize	Vertical	Test Engineer	Ray Li
Detector	Peak		

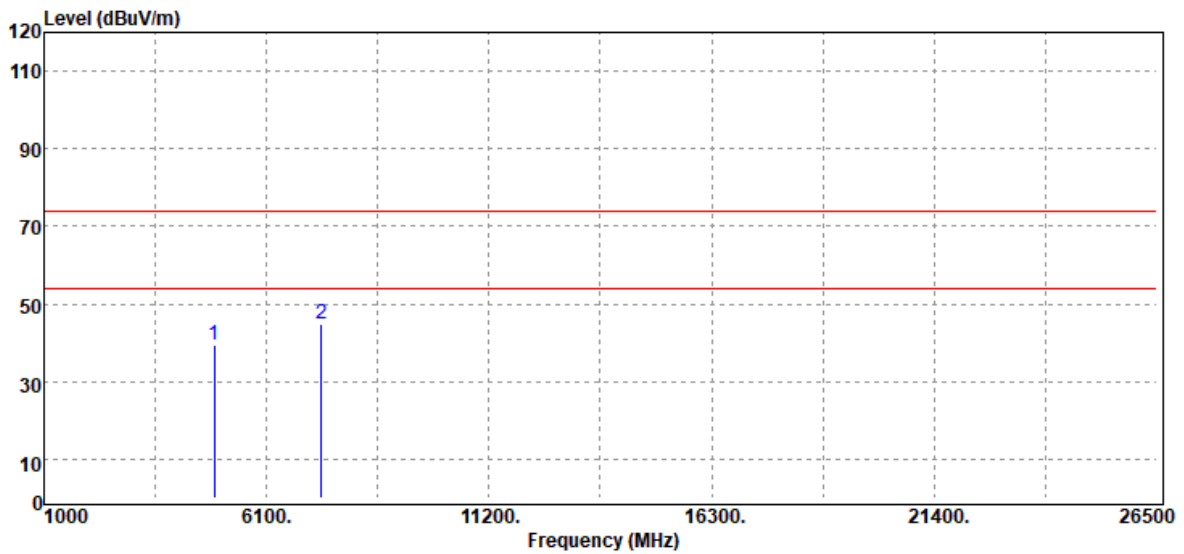

Freq. (MHz)	Detector Mode (PK/QP/AV)	Spectrum Reading Level (dBμV)	Factor (dB)	Actual FS (dBμV/m)	Limit @3m (dBμV/m)	Margin (dB)
4904.00	Peak	33.15	6.17	39.32	74.00	-34.68
7356.00	Peak	31.71	13.05	44.76	74.00	-29.24
N/A						

Remark:

1. Measuring frequencies from 1 GHz to the 10th harmonic of highest fundamental frequency.
2. For above 1GHz,the EUT peak value was under average limit, therefore the Average value compliance with the average limit

Report No.: T210113D03-RP3

Test Mode	IEEE 802.11n HT40 High CH	Temp/Hum	22.4(°C)/ 62%RH
Test Item	Harmonic	Test Date	April 16, 2021
Polarize	Horizontal	Test Engineer	Ray Li
Detector	Peak		

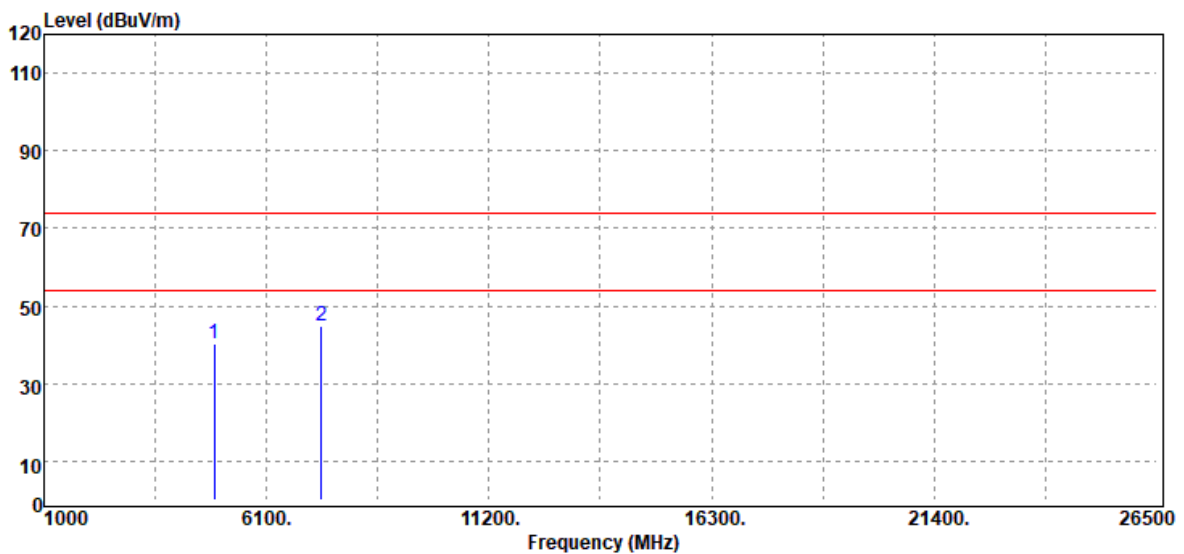

Freq. (MHz)	Detector Mode (PK/QP/AV)	Spectrum Reading Level (dBμV)	Factor (dB)	Actual FS (dBμV/m)	Limit @3m (dBμV/m)	Margin (dB)
4904.00	Peak	34.00	6.17	40.17	74.00	-33.83
7356.00	Peak	31.88	13.05	44.93	74.00	-29.07
N/A						

Remark:

1. Measuring frequencies from 1 GHz to the 10th harmonic of highest fundamental frequency.
2. For above 1GHz,the EUT peak value was under average limit, therefore the Average value compliance with the average limit

- End of Test Report -