

**FCC 47 CFR PART 22 SUBPART H AND PART 24 SUBPART E
&
INDUSTRY CANADA RSS-132 & RSS-133**

TEST REPORT

For

Computer

**FCC Model: AIM8Q, AIM8Qxxxxxxxxxxxxxxxxxx,
AIM-x5BTxxxxxxxxxxxxx(where "x" may be any alphanumeric character,
"-" or blank for marketing purpose and no impact safety related critical
components and constructions)**

IC Model: AIM8Q, AIM-25BT, AIM-35BT, AIM-55BT, AIM-65BT, AIM-75BT

Trade Name: ADVANTECH

Issued to

**Advantech Co.Ltd.
No.1, Alley 20, Lane 26, Rueiguang Road, Neihu District, Taipei 114,
Taiwan, R.O.C.**

Issued by

**Compliance Certification Services Inc.
No.11, Wugong 6th Rd., Wugu Dist.,
New Taipei City 24891, Taiwan. (R.O.C.)
<http://www.ccsrf.com>
service@ccsrf.com
Issued Date: July 19, 2017**

Note: This report shall not be reproduced except in full, without the written approval of Compliance Certification Services Inc. This document may be altered or revised by Compliance Certification Services Inc. personnel only, and shall be noted in the revision section of the document.

Revision History

Rev.	Issue Date	Revisions	Effect Page	Revised By
00	July 19, 2017	Initial Issue	ALL	Angel Cheng

TABLE OF CONTENTS

1. TEST RESULT CERTIFICATION.....	4
2. EUT DESCRIPTION	5
3. TEST METHODOLOGY	6
3.1 EUT CONFIGURATION	6
3.2 EUT EXERCISE.....	6
3.3 GENERAL TEST PROCEDURES.....	6
3.4 DESCRIPTION OF TEST MODES.....	7
4. INSTRUMENT CALIBRATION.....	9
4.1 MEASURING INSTRUMENT CALIBRATION	9
4.2 MEASUREMENT EQUIPMENT USED	9
4.3 MEASUREMENT UNCERTAINTY	9
5. FACILITIES AND ACCREDITATIONS	10
5.1 FACILITIES	10
5.2 EQUIPMENT.....	10
5.3 TABLE OF ACCREDITATIONS AND LISTINGS	11
6. SETUP OF EQUIPMENT UNDER TEST	12
6.1 SETUP CONFIGURATION OF EUT.....	12
6.2 SUPPORT EQUIPMENT	12
7. FCC PART 22 & 24 REQUIREMENTS& INDUSTRY CANADA RSS-132 & RSS-133	13
7.1 99% BANDWIDTH.....	13
7.2 PEAK POWER.....	18
7.3 AVERAGE POWER.....	20
7.4 ERP & EIRP MEASUREMENT	22
7.5 OUT OF BAND EMISSION AT ANTENNA TERMINALS	25
7.6 PEAK TO AVERAGE RATIO	33
7.7 FIELD STRENGTH OF SPURIOUS RADIATION MEASUREMENT	37
7.8 FREQUENCY STABILITY V.S. TEMPERATURE MEASUREMENT	55
7.9 FREQUENCY STABILITY V.S. VOLTAGE MEASUREMENT	57
APPENDIX I PHOTOGRAPHS OF TEST SETUP	59
APPENDIX 1 - PHOTOGRAPHS OF EUT	

1. TEST RESULT CERTIFICATION

Applicant: Advantech Co.Ltd.
 No.1, Alley 20, Lane 26, Rueiguang Road, Neihu District,
 Taipei 114, Taiwan, R.O.C.

Manufacturer: Advantech Co.Ltd.
 No.1, Alley 20, Lane 26, Rueiguang Road, Neihu District,
 Taipei 114, Taiwan, R.O.C.

Equipment Under Test: Computer

Trade Name: ADVANTECH

FCC Model: AIM8Q, AIM8Qxxxxxxxxxxxxxxxxxx,
 AIM-x5BTxxxxxxxxxxxxx(where "x" may be any alphanumeric
 character, "-" or blank for marketing purpose and no impact
 safety related critical components and constructions)

IC Model: AIM8Q, AIM-25BT, AIM-35BT, AIM-55BT, AIM-65BT, AIM-75BT

Date of Test: May 11 ~ July 13, 2017

APPLICABLE STANDARDS	
STANDARD	TEST RESULT
FCC 47 CFR Part 22 Subpart H & Part 24 Subpart E & IC RSS-132 Issue 3: January, 2013 and IC RSS-133 Issue 6: January, 2013	No non-compliance noted

We hereby certify that:

The above equipment was tested by Compliance Certification Services Inc. The test data, data evaluation, test procedures, and equipment configurations shown in this report were made in accordance with the procedures given in TIA/EIA-603-C: 2004 and the energy emitted by the sample EUT tested as described in this report is in compliance with conducted and radiated emission limits of IC RSS-132 Issue 3 and IC RSS-133 Issue 6.

The test results of this report relate only to the tested sample identified in this report.

Approved by:



 Sam Chuang
 Manager
 Compliance Certification Services Inc.

Tested by:



 Timmy Wang
 Engineer
 Compliance Certification Services Inc.

2. EUT DESCRIPTION

Product	Computer
FCC Model No.	AIM8Q, AIM8Qxxxxxxxxxxxxxxxx, AIM-x5BTxxxxxxxxxxxxx(where "x" may be any alphanumeric character, "-" or blank for marketing purpose and no impact safety related critical components and constructions)
IC Model No.	AIM8Q, AIM-25BT, AIM-35BT, AIM-55BT, AIM-65BT, AIM-75BT
Model Discrepancy	All models are electrically identical, different model names are for marketing purpose
Trade Name	ADVANTECH
Received Date	April 6, 2017
Power Supply	1. VDC from Power Adapter Chicony / A16-018N1A I/P: 100-240Vac, 1A, 50-60Hz O/P: 5.15Vdc, 3A, 9.1Vdc, 2A, 18W 2. Battery ADVANTECH / AIM-BAT-8 Rating: 3.8V, 4900mAh, 18.62Wh
Frequency Range	GPRS / EDGE: 850: 824.2 ~ 848.8 MHz GPRS / EDGE: 1900: 1850.2 ~ 1909.8 MHz
Transmit Power (ERP & EIRP Power)	GPRS 850: 22.65 dBm EDGE 850: 21.62 dBm GPRS 1900: 27.08 dBm EDGE 1900: 25.08 dBm
Cellular Phone Protocol	GPRS: GSMK EDGE: 8PSK
Type of Emission	GPRS 850: 245KGXW--- GPRS 1900: 245KGXW---
Antenna Gain	PIFA Antenna GPRS 850: -1.91 dBi GPRS 1900: -1.98 dBi

Notes: We Performed GPRS test, because the output power is be worst. Thus, testing under GPRS would meet the testing criteria for EDGE.

3. TEST METHODOLOGY

Both conducted and radiated testing were performed according to the procedures document on chapter 13 of ANSI C63.10: 2013, TIA/EIA-603-C: 2004 and FCC CFR 47, Part 2, PART 22 SUBPART H AND PART 24 SUBPART E

The tests documented in this report were performed in accordance with IC RSS-132, SPSR503, RSS-133, SPSR510 and ANSI C63.10: 2013 and TIA/EIA-603-C.

3.1 EUT CONFIGURATION

The EUT configuration for testing is installed on RF field strength measurement to meet the Commissions requirement and operating in a manner that intends to maximize its emission characteristics in a continuous normal application.

3.2 EUT EXERCISE

The EUT was operated in the engineering mode to fix the TX frequency that was for the purpose of the measurements.

3.3 GENERAL TEST PROCEDURES

Conducted Emissions

According to the requirements in ANSI C63.10: 2013. Conducted emissions from the EUT measured in the frequency range between 0.15 MHz and 30MHz using CISPR Quasi-peak and average detector modes.

Radiated Emissions

The EUT is placed on a turn table, which is 0.8 m above ground plane. The turntable shall rotate 360 degrees to determine the position of maximum emission level. EUT is set 3m away from the receiving antenna, which varied from 1m to 4m to find out the highest emission. And also, each emission was to be maximized by changing the polarization of receiving antenna both horizontal and vertical. In order to find out the maximum emissions, exploratory radiated emission measurements were made according to the requirements in ANSI C63.10: 2013.

3.4 DESCRIPTION OF TEST MODES

The EUT had been tested under operating condition.

EUT staying in continuous transmitting mode was programmed.

GPRS / EDGE 850:

Channel Low (CH128), Channel Mid (CH190) and Channel High (CH251) were chosen for full testing.

GPRS / EDGE 1900:

Channel Low (CH512), Channel Mid (CH661) and Channel High (CH810) were chosen for full testing.

3.2.1 The worst mode of measurement

For GPRS 850:

Radiated Emission Measurement	
Test Condition	Band edge, Emission for Unwanted and Fundamental
Voltage/Hz	120V/60Hz
Test Mode	Mode 1:EUT power by AC adapter via power cable. Mode 2:EUT power by Battery.
Worst Mode	<input checked="" type="checkbox"/> Mode 1 <input type="checkbox"/> Mode 2 <input type="checkbox"/> Mode 3 <input type="checkbox"/> Mode 4
Position	<input type="checkbox"/> Placed in fixed position. <input checked="" type="checkbox"/> Placed in fixed position at X-Plane (E2-Plane) <input type="checkbox"/> Placed in fixed position at Y-Plane (E1-Plane) <input type="checkbox"/> Placed in fixed position at Z-Plane (H-Plane)

Radiated Emission Measurement Below 1G	
Test Condition	Radiated Emission Below 1G
Voltage/Hz	120V/60Hz
Test Mode	Mode 1:EUT power by AC adapter via power cable. Mode 2:EUT power by Battery.
Worst Mode	<input checked="" type="checkbox"/> Mode 1 <input type="checkbox"/> Mode 2 <input type="checkbox"/> Mode 3 <input type="checkbox"/> Mode 4

Remark:

1. The worst mode was record in this test report.
2. The EUT pre-scanned in three axis ,X,Y, Z for radiated measurement. The worst cases (X-Plane) were recorded in this report.
3. AC power line conducted emission and for below 1G radiation emission were performed the EUT transmit at the highest output power channel as worse case.

For GPRS 1900:

Radiated Emission Measurement	
Test Condition	Band edge, Emission for Unwanted and Fundamental
Voltage/Hz	120V/60Hz
Test Mode	Mode 1:EUT power by AC adapter via power cable. Mode 2:EUT power by Battery.
Worst Mode	<input checked="" type="checkbox"/> Mode 1 <input type="checkbox"/> Mode 2 <input type="checkbox"/> Mode 3 <input type="checkbox"/> Mode 4
Position	<input type="checkbox"/> Placed in fixed position. <input type="checkbox"/> Placed in fixed position at X-Plane (E2-Plane) <input checked="" type="checkbox"/> Placed in fixed position at Y-Plane (E1-Plane) <input type="checkbox"/> Placed in fixed position at Z-Plane (H-Plane)

Radiated Emission Measurement Below 1G	
Test Condition	Radiated Emission Below 1G
Voltage/Hz	120V/60Hz
Test Mode	Mode 1:EUT power by AC adapter via power cable. Mode 2:EUT power by Battery.
Worst Mode	<input checked="" type="checkbox"/> Mode 1 <input type="checkbox"/> Mode 2 <input type="checkbox"/> Mode 3 <input type="checkbox"/> Mode 4

Remark:

1. *The worst mode was record in this test report.*
2. *The EUT pre-scanned in three axis ,X,Y, Z for radiated measurement. The worst cases (Y-Plane) were recorded in this report.*
3. *AC power line conducted emission and for below 1G radiation emission were performed the EUT transmit at the highest output power channel as worse case.*

4. INSTRUMENT CALIBRATION

4.1 MEASURING INSTRUMENT CALIBRATION

The measuring equipment, which was utilized in performing the tests documented herein, has been calibrated in accordance with the manufacturer's recommendations for utilizing calibration equipment, which is traceable to recognized national standards.

4.2 MEASUREMENT EQUIPMENT USED

Equipment Used for Emissions Measurement

Remark: Each piece of equipment is scheduled for calibration once a year and Loop Antenna is scheduled for calibration once three years.

Name of Equipment	Manufacturer	Model	Serial Number	Calibration Date	Calibration Due
Power Meter	Anritsu	ML2495A	1012009	07/04/2016	07/03/2017
Power Sensor	Anritsu	MA2411B	917072	07/04/2016	07/03/2017
Base Station	R&S	CMU 200	101245	07/29/2016	07/28/2017
Base Station	Anritsu	MT-8820C	6200938900	07/26/2016	07/25/2017
Spectrum Analyzer	R&S	FSV 40	101073	10/05/2016	10/04/2017

Wugu 966 Chamber A					
Name of Equipment	Manufacturer	Model	Serial Number	Calibration Date	Calibration Due
Bilog Antenna	Sunol Sciences	JB3	A030105	07/03/2016	07/02/2017
Horn Antenna	EMCO	3117	00055165	02/20/2017	02/19/2018
Pre-Amplifier	EMCI	EMC 012635	980151	06/23/2016	06/22/2017
Pre-Amplifier	EMEC	EM330	060609	06/08/2016	06/07/2017
Spectrum Analyzer	Agilent	E4446A	US42510252	12/05/2016	12/04/2017
Loop Ant	COM-POWER	AL-130	121051	03/02/2017	03/1/2018
Antenna Tower	CCS	CC-A-1F	N/A	N.C.R	N.C.R
Controller	CCS	CC-C-1F	N/A	N.C.R	N.C.R
Turn Table	CCS	CC-T-1F	N/A	N.C.R	N.C.R
Software	EZ-EMC (CCS-3A1RE)				

4.3 MEASUREMENT UNCERTAINTY

PARAMETER	UNCERTAINTY
3M Semi Anechoic Chamber / 30M~200M	+/- 4.0138
3M Semi Anechoic Chamber / 200M~1000M	+/- 3.9483
3M Semi Anechoic Chamber / 1G~8G	+/- 2.5975
3M Semi Anechoic Chamber / 8G~18G	+/- 2.6112
3M Semi Anechoic Chamber / 18G~26G	+/- 2.7389
3M Semi Anechoic Chamber / 26G~40G	+/- 2.9683

Remark: This uncertainty represents an expanded uncertainty expressed at approximately the 95% confidence level using a coverage factor of $k=2$.

5. FACILITIES AND ACCREDITATIONS

5.1 FACILITIES

No.199, Chunghsen Road, Hsintien City, Taipei Hsien, Taiwan, R.O.C.

Tel: 886-2-2217-0894 / Fax: 886-2-2217-1029

No.11, Wugong 6th Rd., Wugu Dist., New Taipei City 24891, Taiwan. (R.O.C.)

Tel: 886-2-2299-9720 / Fax: 886-2-2298-4045

No.81-1, Lane 210, Bade 2nd Rd., Lujhu Township, Taoyuan County 33841, TAIWAN, R.O.C.

Tel: 886-3-324-0332 / Fax: 886-3-324-5235

The sites are constructed in conformance with the requirements of ANSI C63.7, ANSI C63.10:2013 and CISPR Publication 22.

5.2 EQUIPMENT



Radiated emissions are measured with one or more of the following types of linearly polarized antennas: tuned dipole, biconical, log periodic, bi-log, and/or ridged waveguide, horn. Spectrum analyzers with pre-selectors and quasi-peak detectors are used to perform radiated measurements.

Conducted emissions are measured with Line Impedance Stabilization Networks and EMI Test Receivers.

Calibrated wideband preamplifiers, coaxial cables, and coaxial attenuators are also used for making measurements.

All receiving equipment conforms to CISPR Publication 16-1, "Radio Interference Measuring Apparatus and Measurement Methods."

5.3 TABLE OF ACCREDITATIONS AND LISTINGS

Country	Agency	Scope of Accreditation	Logo
USA	FCC	3M Semi Anechoic Chamber (FCC MRA: TW1039) to perform FCC Part 15 measurements	 FCC MRA: TW1039
Taiwan	TAF	LP0002, RTTE01, FCC Method-47 CFR Part 15 Subpart C, D, E, RSS-210, RSS-310 IDA TS SRD, AS/NZS 4268, AS/NZS 4771, TS 12.1 & 12.2, ETSI EN 300 440-1, ETSI EN 300 440-2, ETSI EN 300 328, ETSI EN 300 220-1, ETSI EN 300 220-2, ETSI EN 301 893, ETSI EN 301 489-1/3/7/17 FCC OET Bulletin 65 + Supplement C, EN 50360, EN 50361, EN 50371, RSS 102, EN 50383, EN 50385, EN 50392, IEC 62209, CNS 14958-1, CNS 14959 FCC Method -47 CFR Part 15 Subpart B IEC / EN 61000-3-2, IEC / EN 61000-3-3, IEC / EN 61000-4-2/3/4/5/6/8/11	
Canada	Industry Canada	3M Semi Anechoic Chamber (IC 2324G-1 / IC 2324G-2) to perform	 IC 2324G-1 IC 2324G-2

** No part of this report may be used to claim or imply product endorsement by A2LA or any agency of the US Government.*

6. SETUP OF EQUIPMENT UNDER TEST

6.1 SETUP CONFIGURATION OF EUT

See test photographs attached in Appendix I for the actual connections between EUT and support equipment.

6.2 SUPPORT EQUIPMENT

No.	Device Type	Brand	Model	FCC ID	Series No.	Data Cable	Power Cord
	N/A						

Remark:

1. *All the equipment/cables were placed in the worst-case configuration to maximize the emission during the test.*
2. *Grounding was established in accordance with the manufacturer's requirements and conditions for the intended use.*

7. FCC PART 22 & 24 REQUIREMENTS & INDUSTRY CANADA RSS-132 & RSS-133

7.1 99% BANDWIDTH

LIMIT

None; for reporting purposes only.

Test Configuration

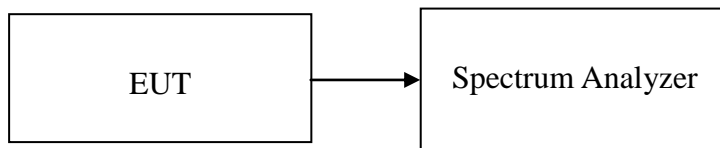

TEST PROCEDURE

The transmitter output is connected to the spectrum analyzer. The RBW is set to 1% to 3% of the 99 % bandwidth. The VBW is set to 3 times the RBW. The sweep time is coupled.

TEST RESULTS

No non-compliance noted.

Test Data

Test Mode	CH	Frequency (MHz)	99% Bandwidth (kHz)
GPRS 850	128	824.20	243.5897
	190	836.60	243.5897
	251	848.80	245.1923

Test Mode	CH	Frequency (MHz)	99% Bandwidth (kHz)
GPRS 1900	512	1850.20	245.1923
	661	1880.00	245.1923
	810	1909.80	243.5897

Test Plot

GPRS 850 (CH Low)

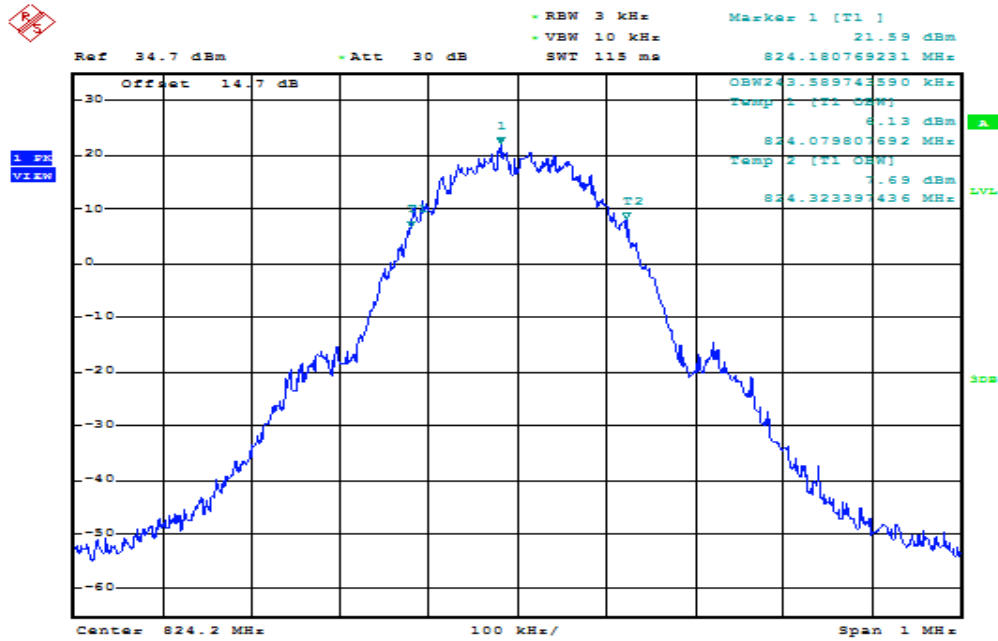

Date: 11.MAY.2017 15:09:13

GPRS 850 (CH Mid)

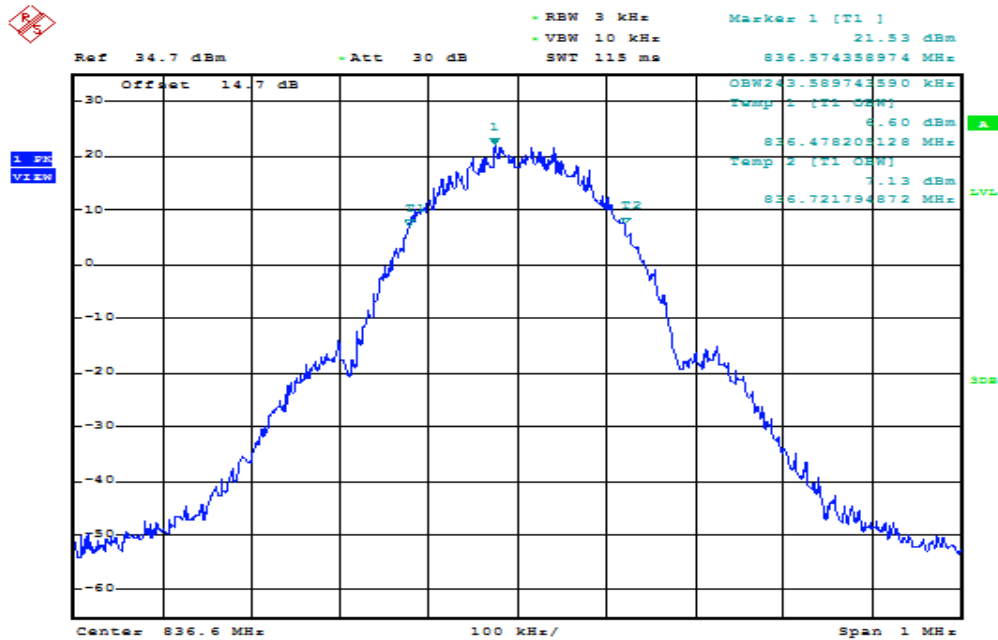

Date: 11.MAY.2017 15:10:35

GPRS 850(CH High)

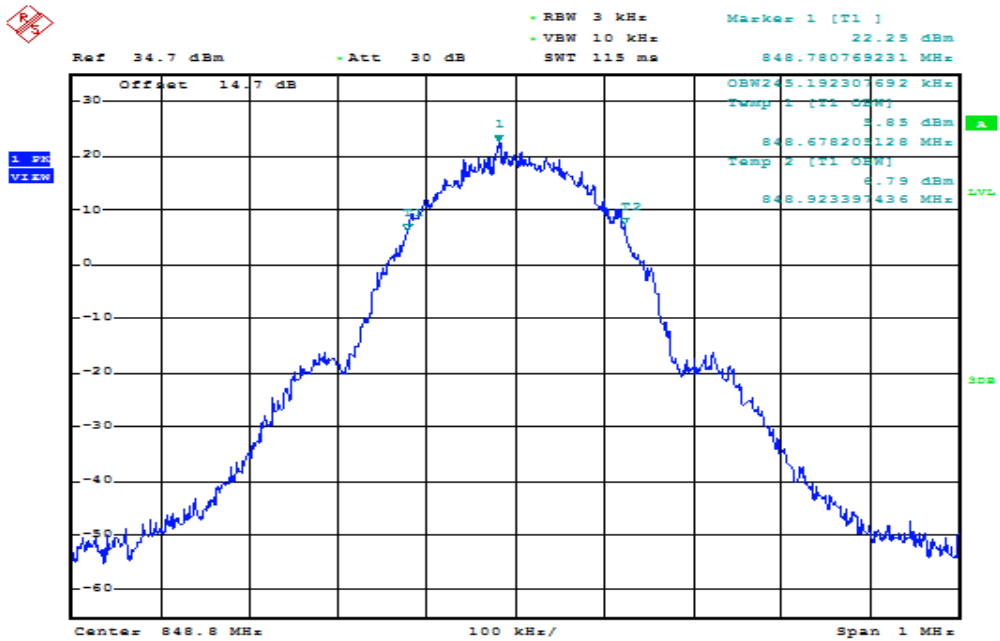

Date: 11.MAY.2017 15:11:43

GPRS 1900 (CH Low)

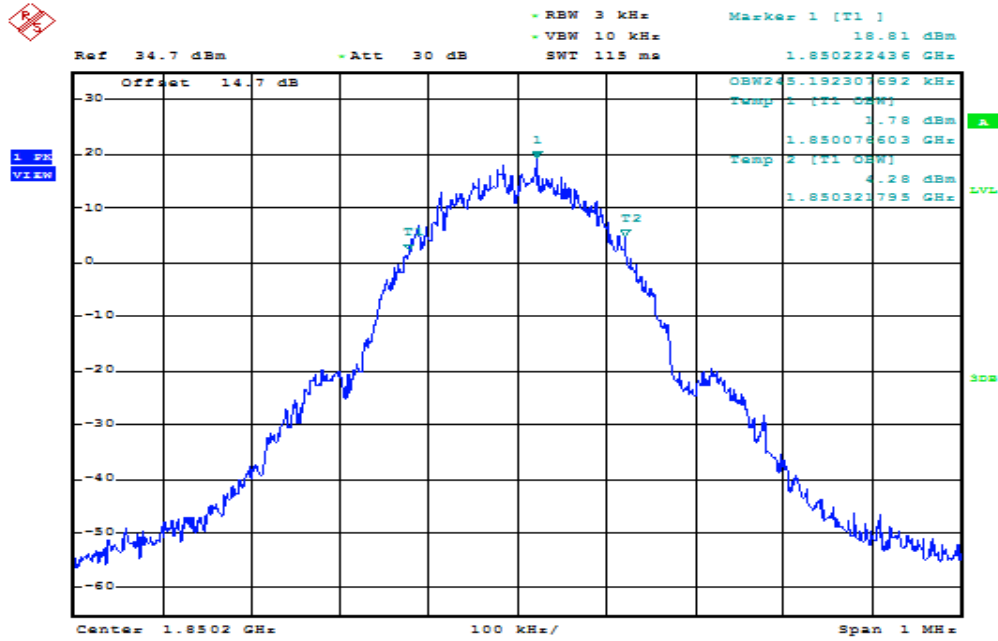

Date: 11.MAY.2017 15:58:09

GPRS 1900 (CH Mid)

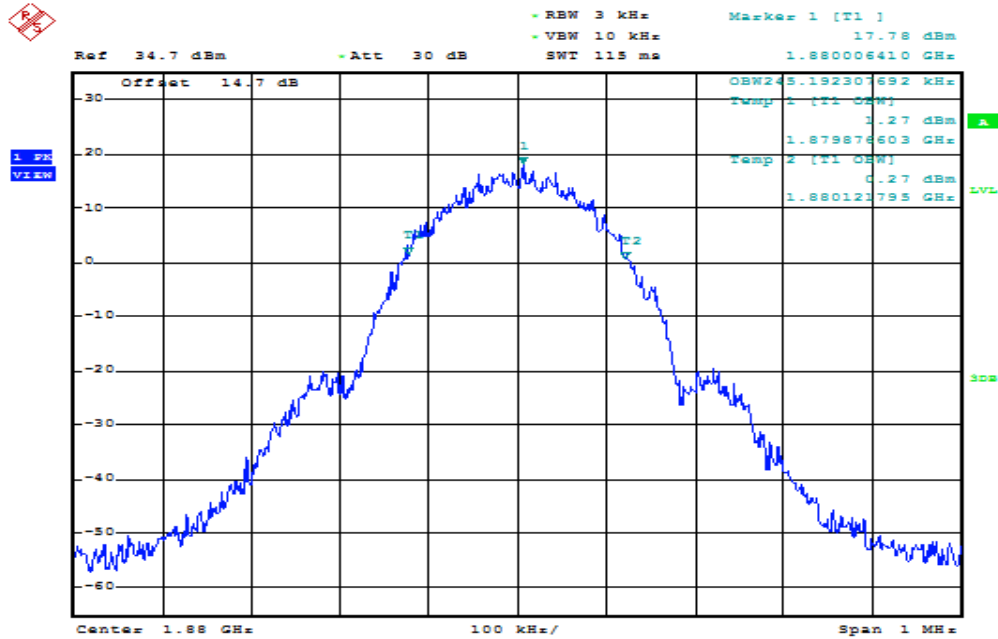

Date: 11.MAY.2017 15:57:21

GPRS 1900 (CH High)

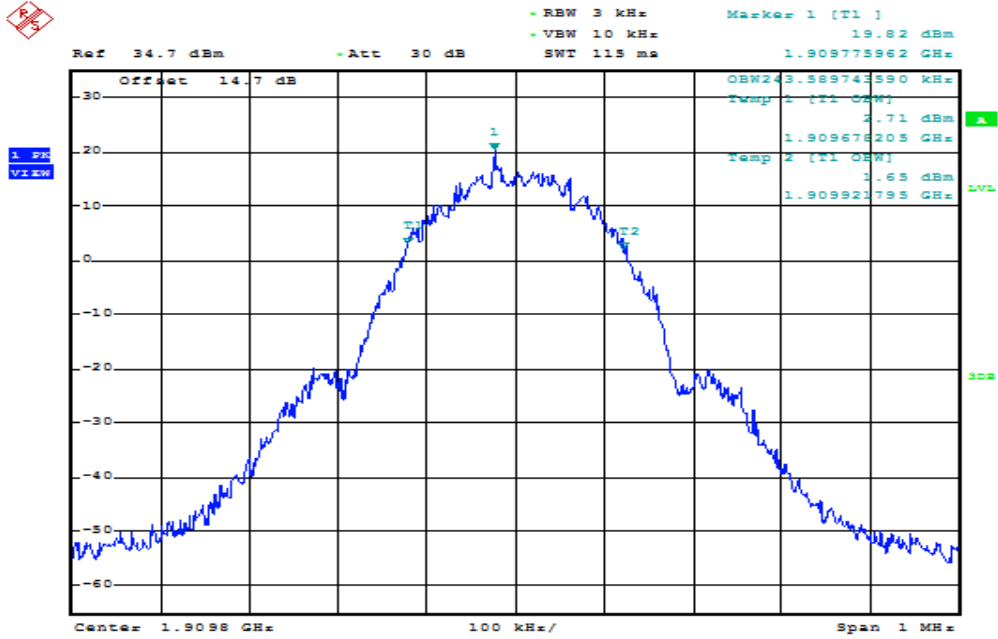

Date: 11.MAY.2017 15:56:26

7.2 PEAK POWER

LIMIT

According to FCC §2.1046.

Test Configuration

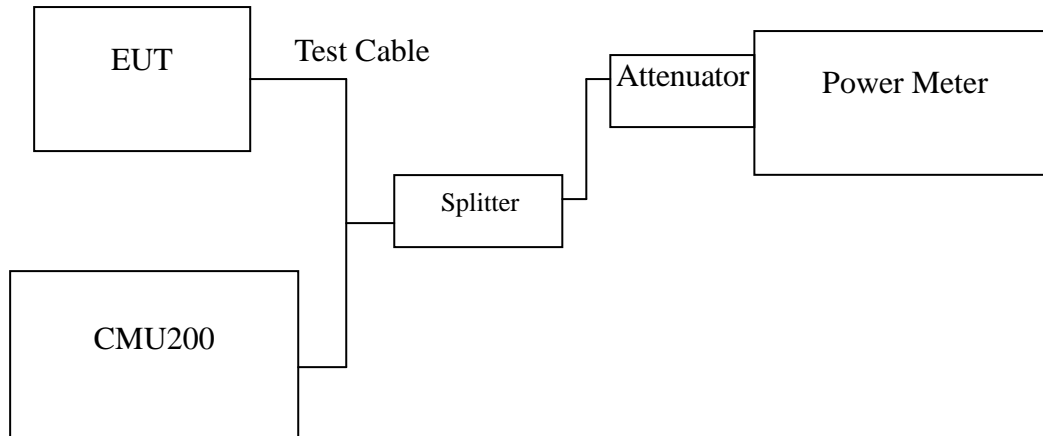

Remark: Measurement setup for testing on Antenna connector

TEST PROCEDURE

The transmitter output was connected to a calibrated attenuator, the other end of which was connected to a power meter. Transmitter output was read off the power meter in dBm. The power output at the transmitter antenna port was determined by adding the value of the attenuator to the power meter reading.

TEST RESULTS

No non-compliance noted.

Test Data

Test Mode	CH	Frequency (MHz)	Peak Power (dBm)	Output Power (W)
GPRS 850	128	824.20	32.1	1.62181
	190	836.60	32.2	1.65959
	251	848.80	32.0	1.58489

Test Mode	CH	Frequency (MHz)	Peak Power (dBm)	Output Power (W)
GPRS 1900	512	1850.20	29.3	0.85114
	661	1880.00	29.4	0.87096
	810	1909.80	29.2	0.83176

Test Mode	CH	Frequency (MHz)	Peak Power (dBm)	Output Power (W)
EDGE 850	128	824.20	27.5	0.56234
	190	836.60	27.5	0.56234
	251	848.80	27.5	0.56234

Test Mode	CH	Frequency (MHz)	Peak Power (dBm)	Output Power (W)
EDGE 1900	512	1850.20	26.0	0.39811
	661	1880.00	26.0	0.39811
	810	1909.80	26.0	0.39811

Remark: The value of factor includes both the loss of cable and external attenuator

7.3 AVERAGE POWER

LIMIT

For reporting purposes only.

Test Configuration

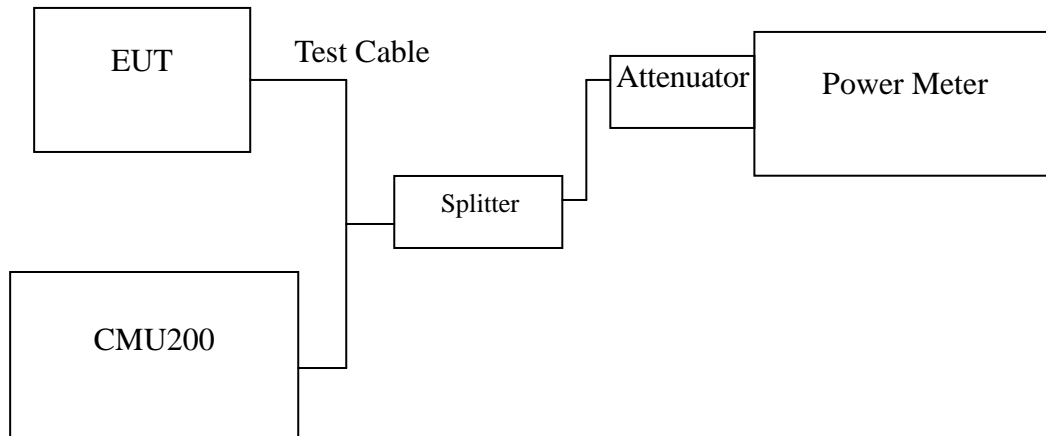

Remark: Measurement setup for testing on Antenna connector

TEST PROCEDURE

The transmitter output was connected to a calibrated attenuator, the other end of which was connected to a power meter. Transmitter output was read off the power meter in dBm. The power output at the transmitter antenna port was determined by adding the value of the attenuator to the power meter reading.

TEST RESULTS

No non-compliance noted.

Test Data

Test Mode	CH	Frequency (MHz)	AVG Power (dBm)	Output Power (W)
GPRS 850	128	824.20	31.9	1.54882
	190	836.60	31.9	1.54882
	251	848.80	31.8	1.51356

Test Mode	CH	Frequency (MHz)	AVG Power (dBm)	Output Power (W)
GPRS 1900	512	1850.20	29.0	0.79433
	661	1880.00	29.2	0.83176
	810	1909.80	28.9	0.77625

Test Mode	CH	Frequency (MHz)	AVG Power (dBm)	Output Power (W)
EDGE 850	128	824.20	25.5	0.35481
	190	836.60	25.5	0.35481
	251	848.80	25.5	0.35481

Test Mode	CH	Frequency (MHz)	AVG Power (dBm)	Output Power (W)
EDGE 1900	512	1850.20	25.0	0.31623
	661	1880.00	25.0	0.31623
	810	1909.80	25.0	0.31623

Remark: The value of factor includes both the loss of cable and external attenuator

7.4 ERP & EIRP MEASUREMENT

LIMIT

According to FCC §2.1046

RSS-132 § 5.4 The maximum (ERP) shall be 11.5Watts for mobile stations.

RSS133 § 6.4: Mobile stations and hand-held portables are limited to 2 watts maximum (EIRP).

Test Configuration

Below 1 GHz

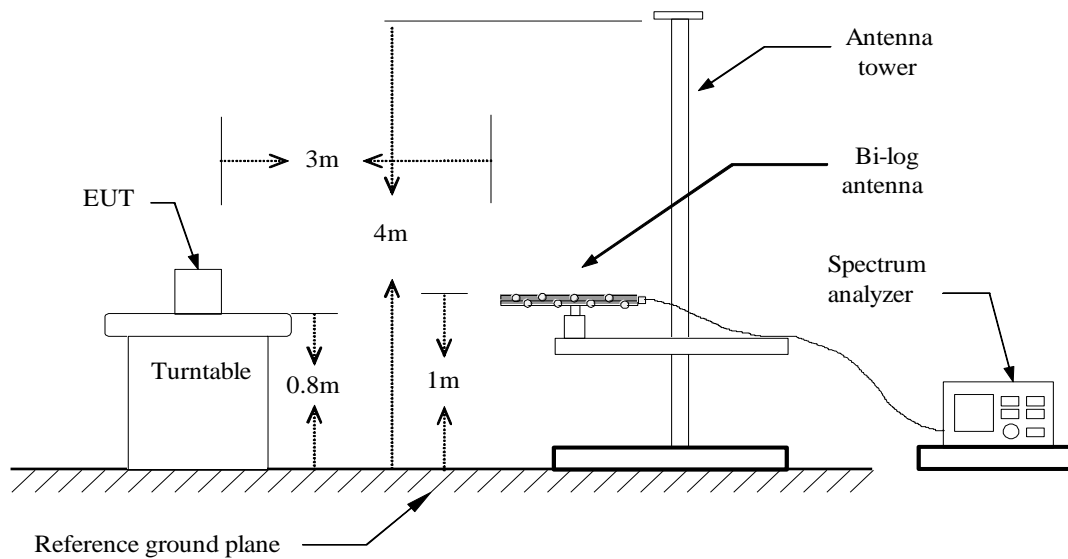

Above 1 GHz

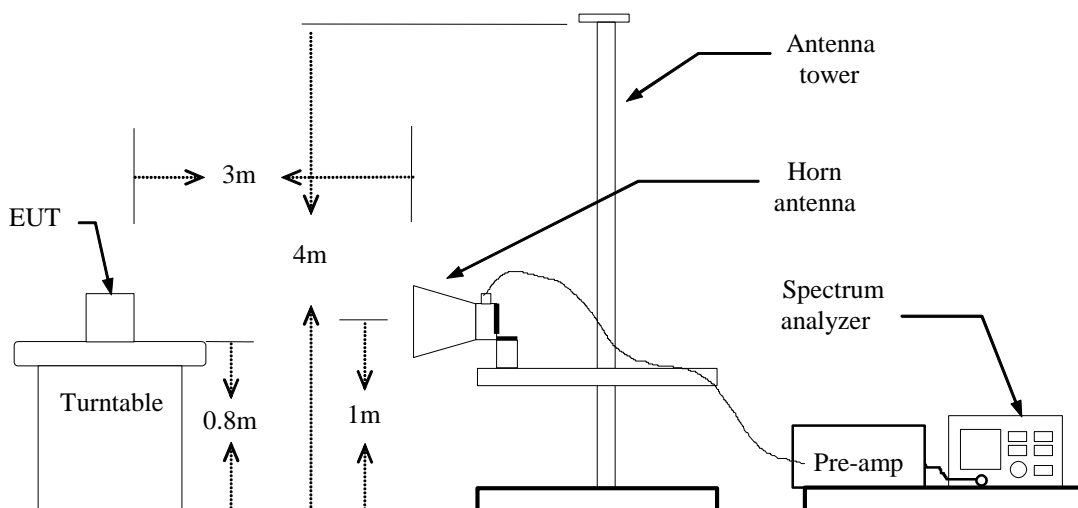

For Substituted Method Test Set-UP

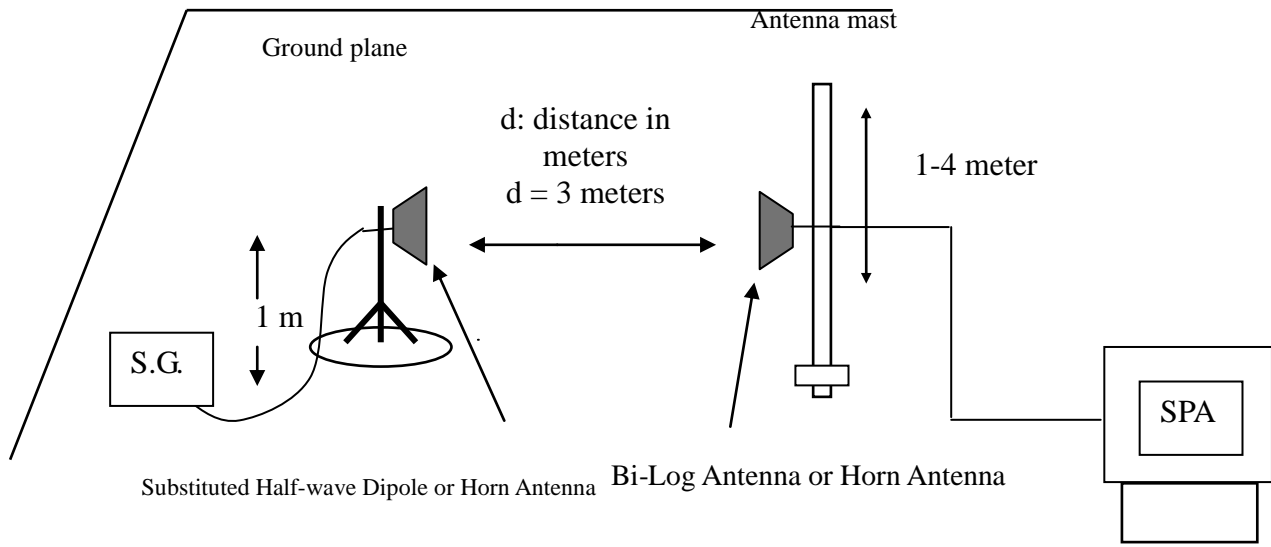

TEST PROCEDURE

The EUT was placed on an non-conductive turntable using a non-conductive support. The radiated emission at the fundamental frequency was measured at 3 m with a test antenna and EMI spectrum analyzer.

During the measurement of the EUT, the resolution bandwidth was set to 5MHz and the average bandwidth was set to 50MHz. The highest emission was recorded with the rotation of the turntable and the lowering of the test antenna. The reading was recorded and the field strength (E in dBuV/m) was calculated.

ERP in frequency band 824-849MHz, and EIRP in frequency band 1851.25 –1910MHz were measured using a substitution method. The EUT was replaced by half-wave dipole (824-849MHz) or horn antenna (1851.25-1910MHz) connected to a signal generator. The spectrum analyzer reading was recorded and ERP/EIRP was calculated as follows:

$$ERP = \text{S.G. output (dBm)} + \text{Antenna Gain (dBi)} - \text{Cable (dB)} - 2.15$$

$$EIRP = \text{S.G. output (dBm)} + \text{Antenna Gain (dBi)} - \text{Cable (dB)}$$

TEST RESULTS

No non-compliance noted.

GPRS 850 TEST DATA

Channel	Frequency (MHz)	S.G. (dBm)	Ant.Gain (dBi)	Emission level (dBm)	Limit (dBm)	Margin (dB)	Antenna Pol.
128	824.4800	19.93	1.23	21.16	38.45	-17.29	V
	824.7200	21.28	1.23	22.51	38.45	-15.94	H
190	836.6600	21.21	1.2	22.41	38.45	-16.04	V
	836.9600	23.11	1.2	24.31	38.45	-14.14	H
251	849.0200	20.77	1.17	21.94	38.45	-16.51	V
	849.4400	21.48	1.17	22.65	38.45	-15.80	H

EDGE 850 TEST DATA

Channel	Frequency (MHz)	S.G. (dBm)	Ant.Gain (dBi)	Emission level (dBm)	Limit (dBm)	Margin (dB)	Antenna Pol.
128	824.5400	19.85	1.23	21.08	38.45	-17.37	V
	824.8400	19.81	1.23	21.04	38.45	-17.41	H
190	837.0200	19.94	1.2	21.14	38.45	-17.31	V
	836.8400	20.15	1.2	21.35	38.45	-17.10	H
251	836.8400	20.15	1.2	21.35	38.45	-17.10	V
	849.5000	20.45	1.17	21.62	38.45	-16.83	H

GPRS 1900 TEST DATA

Channel	Frequency (MHz)	S.G. (dBm)	Ant.Gain (dBi)	Emission level (dBm)	Limit (dBm)	Margin (dB)	Antenna Pol.
512	1851.000	24.29	1.5	25.79	33.00	-7.21	V
	1850.160	24.61	1.5	26.11	33.00	-6.89	H
661	1880.280	25.58	1.5	*27.08	33.00	-5.92	V
	1880.280	22.3	1.5	23.80	33.00	-9.20	H
810	1909.920	22.45	1.5	23.95	33.00	-9.05	V
	1910.040	21.12	1.5	22.62	33.00	-10.38	H

EDGE 1900 TEST DATA

Channel	Frequency (MHz)	S.G. (dBm)	Ant.Gain (dBi)	Emission level (dBm)	Limit (dBm)	Margin (dB)	Antenna Pol.
512	1850.280	23.58	1.5	25.08	33.00	-7.92	V
	1850.160	23.58	1.5	25.08	33.00	-7.92	H
661	1879.800	23.16	1.5	24.66	33.00	-8.34	V
	1880.040	17.56	1.5	19.06	33.00	-13.94	H
810	1909.800	20.13	1.5	21.63	33.00	-11.37	V
	1909.680	19.34	1.5	20.84	33.00	-12.16	H

7.5 OUT OF BAND EMISSION AT ANTENNA TERMINALS

LIMIT

According to FCC §2.1051, FCC §22.917, FCC §24.238(a).

According to RSS-132 (5.5), RSS-133 (6.5).

Out of Band Emissions: The mean power of emission must be attenuated below the mean power of the non-modulated carrier (P) on any frequency twice or more than twice the fundamental frequency by at least $43 + 10 \log P$ dB.

Mobile Emissions in Base Frequency Range: The mean power of any emissions appearing in the base station frequency range from cellular mobile transmitters operated must be attenuated to a level not exceed -80 dBm at the transmit antenna connector.

Band Edge Requirements: In the 1MHz bands immediately outside and adjacent to the frequency block, a resolution bandwidth of at least 1% of the emission bandwidth of the fundamental emission of the transmitter may be employed to measure the Out of band Emission

Test Configuration

Out of band emission at antenna terminals:

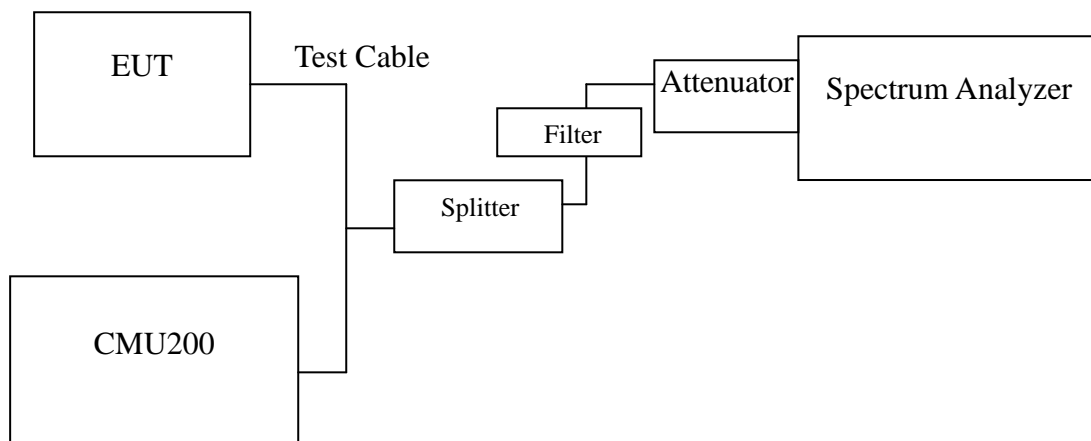

Notes: Filter for GPRS 850 frequency: 800MHz - 1GHz
 Filter for GPRS 1900 frequency: 1800MHz - 2GHz

TEST PROCEDURE

The RF output of the transceiver was connected to a spectrum analyzer through appropriate attenuation. The resolution bandwidth of the spectrum analyzer was set at 1MHz, sufficient scans were taken to show the out of band Emissions if any up to 10th harmonic.

For the out of band: Set the RBW, VBW = 1MHz, Start=30MHz, Stop= 10 th harmonic. Limit = -13dBm

Band Edge Requirements (824 MHz and 849 MHz /1850MHz and 1910MHz): In the 1 MHz bands immediately outside and adjacent to the frequency block, a resolution bandwidth of at least 1 percent of the emission bandwidth of the fundamental emission of the transmitter may be employed to measure the out of band Emissions. Limit, -13dBm.

TEST RESULTS

No non-compliance noted.

Test Data

Mode	CH	Location	Description
GPRS 850	128	Figure 8-1	Conducted spurious emissions, 30MHz - 20GHz
	190	Figure 8-2	Conducted spurious emissions, 30MHz - 20GHz
	251	Figure 8-3	Conducted spurious emissions, 30MHz - 20GHz

Mode	CH	Location	Description
GPRS 1900	512	Figure 9-1	Conducted spurious emissions, 30MHz - 20GHz
	661	Figure 9-2	Conducted spurious emissions, 30MHz - 20GHz
	810	Figure 9-3	Conducted spurious emissions, 30MHz - 20GHz

Mode	CH	Location	Description
GPRS 850	128	Figure 10-1	Band Edge emissions
	251	Figure 10-2	Band Edge emissions

Mode	CH	Location	Description
GPRS 1900	512	Figure 11-1	Band Edge emissions
	810	Figure 11-2	Band Edge emissions

Test Plot

GPRS 850

Figure 8-1: Out of Band emission at antenna terminals – GPRS CH Low

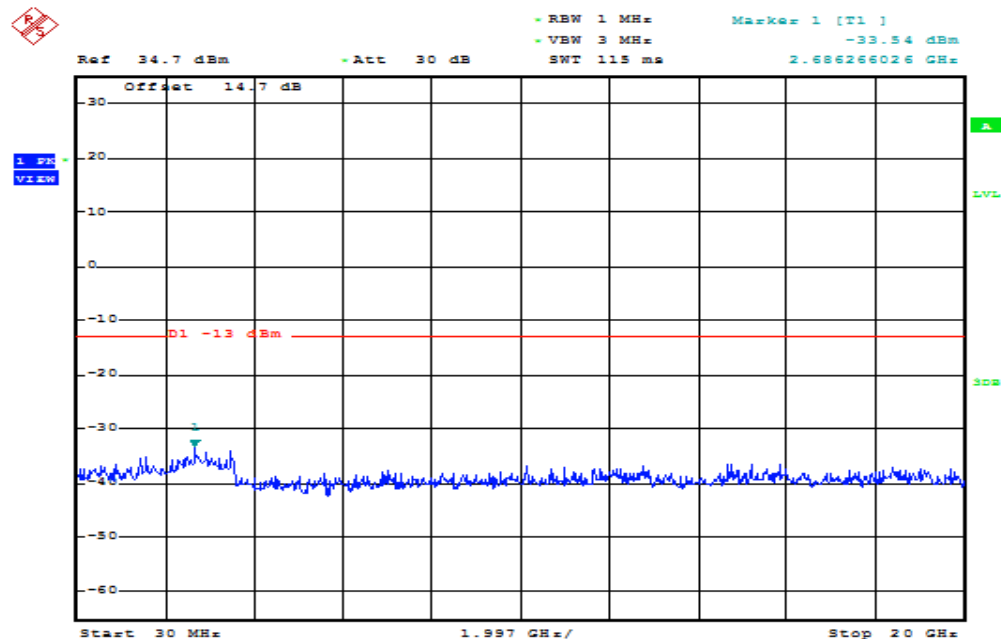

Date: 11.MAY.2017 15:16:48

Figure 8-2: Out of Band emission at antenna terminals – GPRS CH Mid

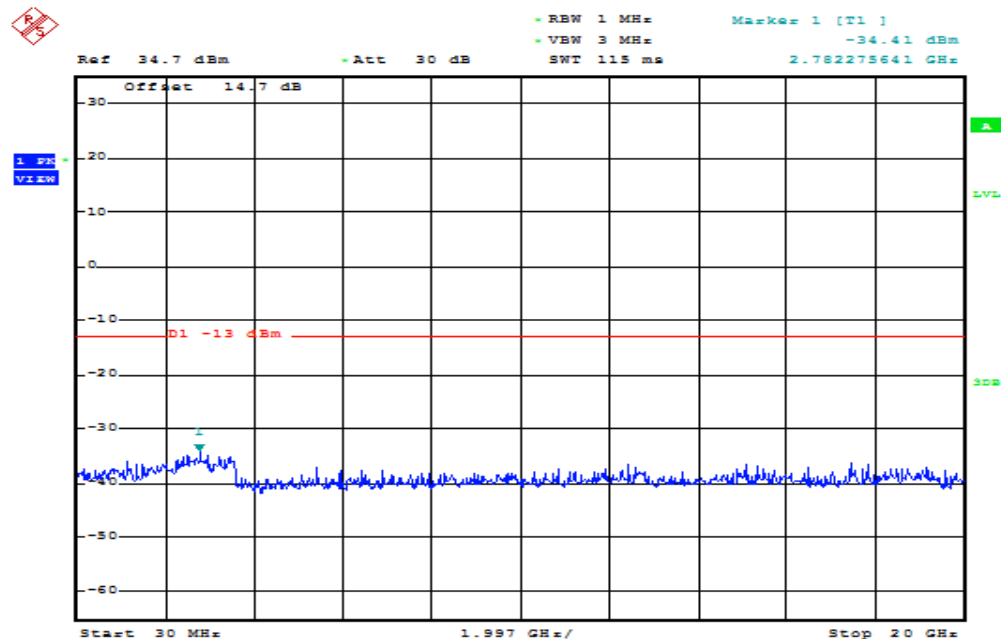

Date: 11.MAY.2017 15:17:17

Figure 8-3: Out of Band emission at antenna terminals – GPRS CH High

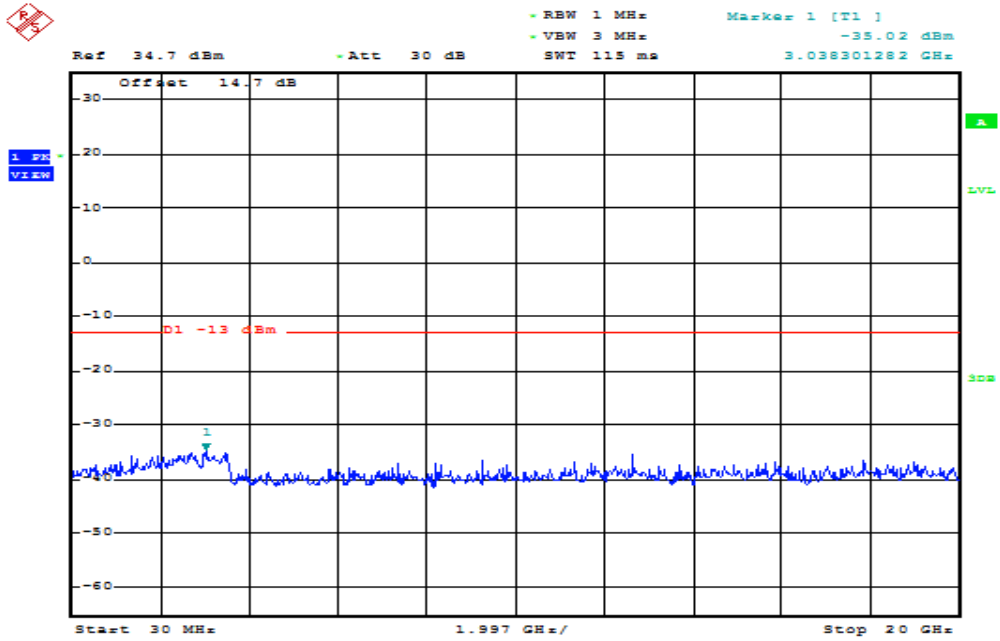

Date: 11.MAY.2017 15:17:47

GPRS 1900

Figure 9-1: Out of Band emission at antenna terminals – GPRS CH Low

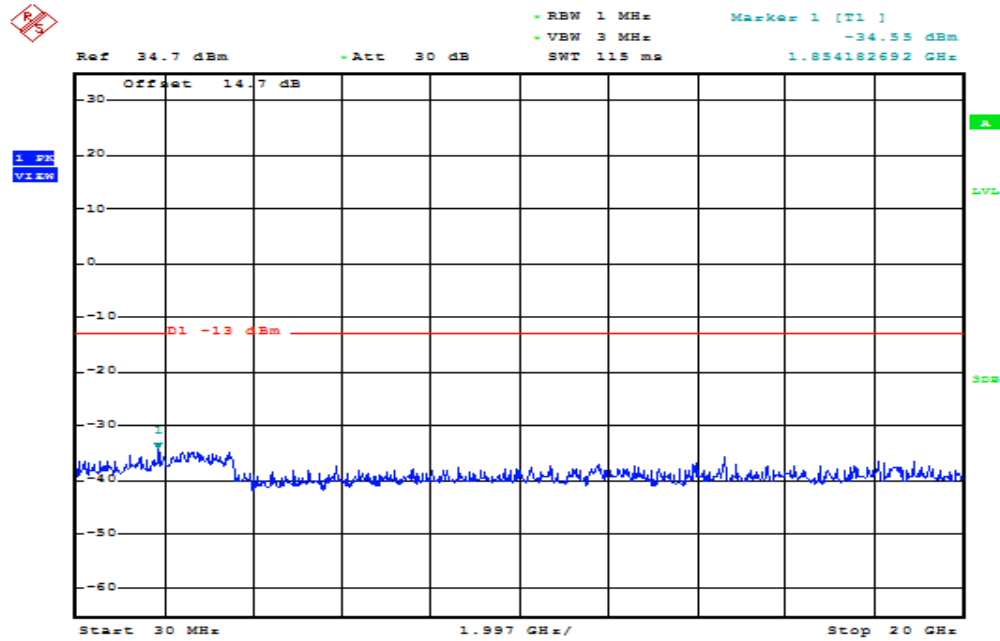

Date: 11.MAY.2017 15:52:08

Figure 9-2: Out of Band emission at antenna terminals – GPRS CH Mid

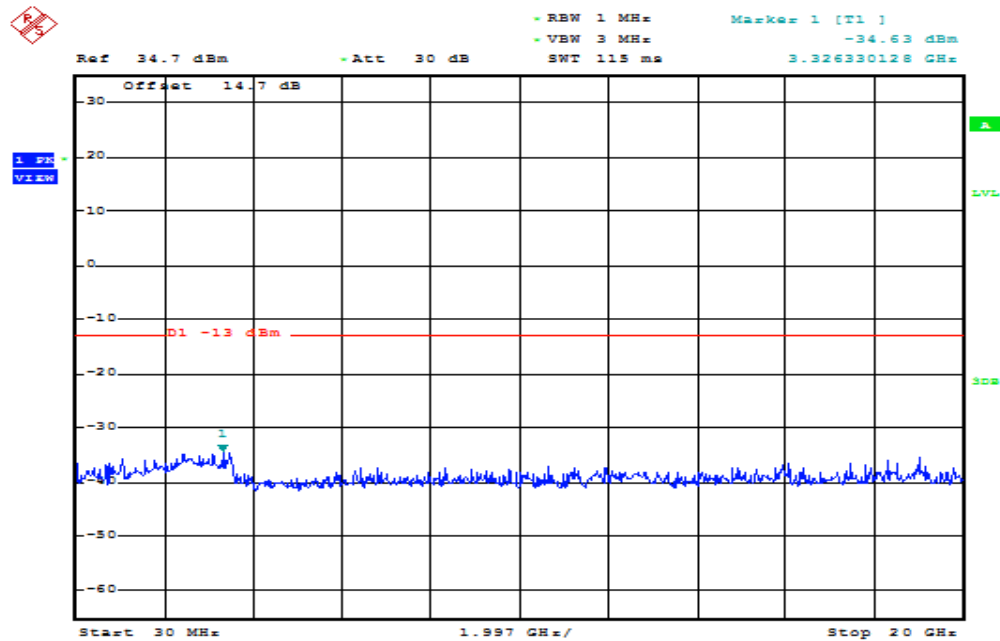

Date: 11.MAY.2017 15:51:37

Figure 9-3: Out of Band emission at antenna terminals – GPRS CH High

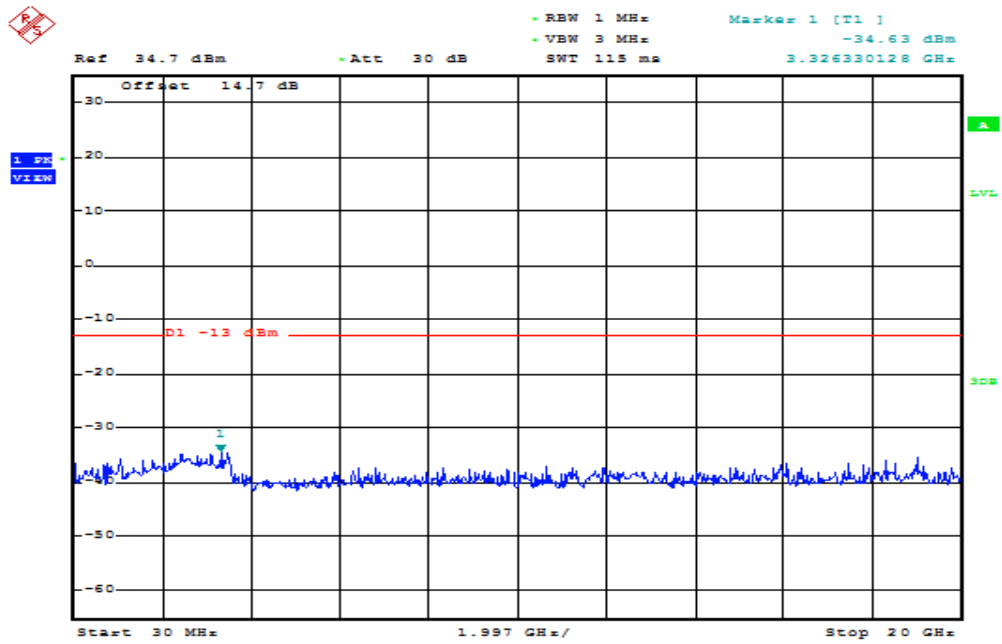

Date: 11.MAY.2017 15:51:37

GPRS 850

Figure 10-1: Band Edge emissions – GPRS CH Low

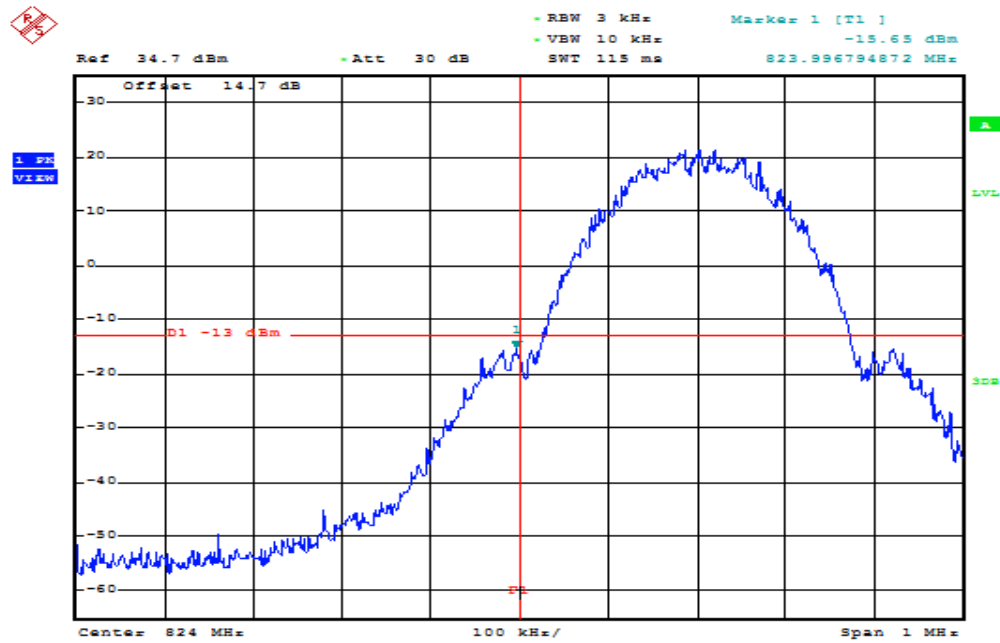

Date: 11.MAY.2017 15:14:49

Figure 10-2: Band Edge emissions –GPRS CH High

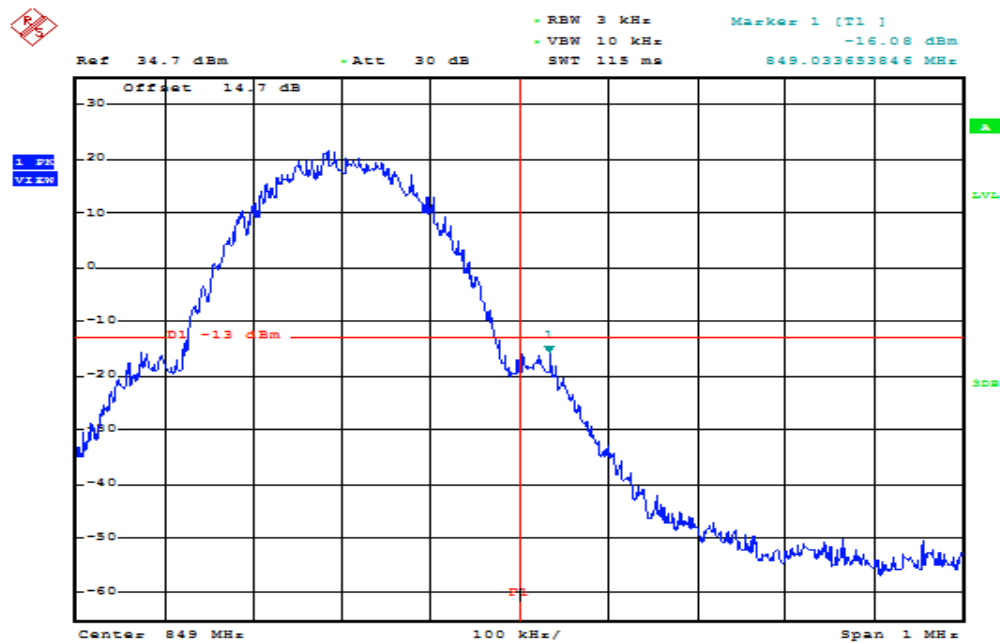

Date: 11.MAY.2017 15:13:46

GPRS 1900

Figure 11-1: Band Edge emissions – GPRS CH Low

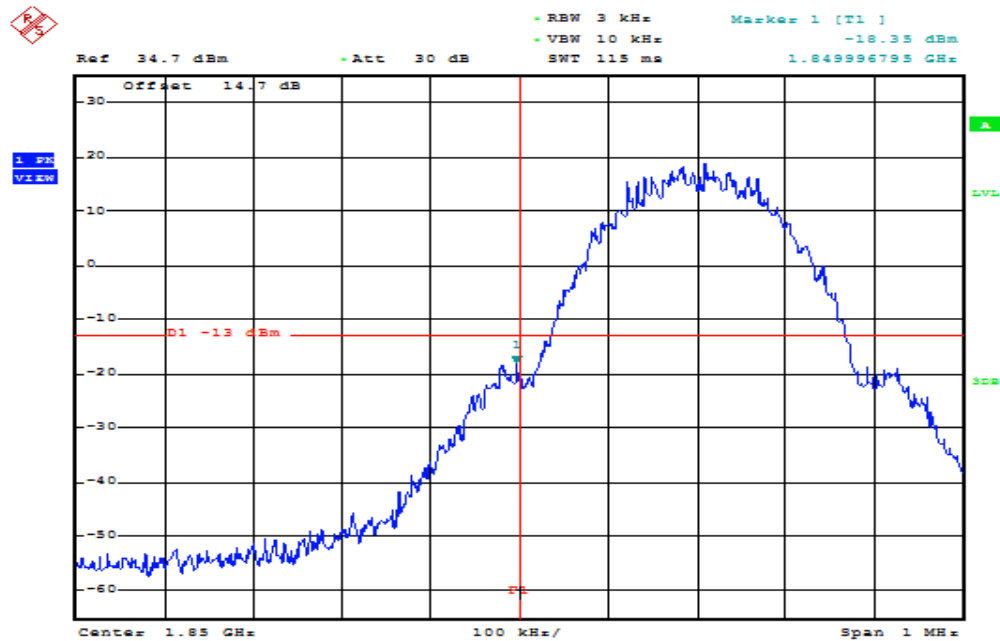

Date: 11.MAY.2017 15:54:05

Figure 11-2: Band Edge emissions – GPRS CH High

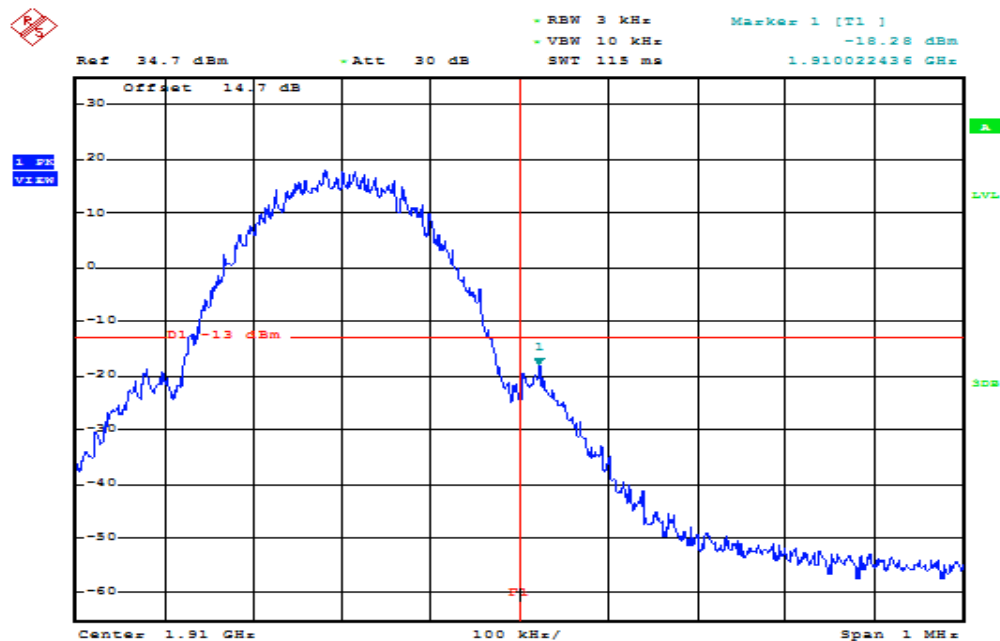

Date: 11.MAY.2017 15:55:15

7.6 PEAK TO AVERAGE RATIO

Limit

FCC §22.913(d), Band 5

In measuring transmissions in this band using an average power technique, the peak to-average ratio (PAR) of the transmission may not exceed 13 dB

FCC §24.232(d), Band 2

In measuring transmissions in this band using an average power technique, the peak to-average ratio (PAR) of the transmission may not exceed 13 dB

RSS-132 section 5.4 and RSS-133 section 6.4

The peak-to-average power ratio (PAPR) of the transmitter shall not exceed 13 dB for more than 0.1% of the time using a signal corresponding to the highest PAPR during periods of continuous transmission.

Test Procedures

1. Set resolution/measurement bandwidth \geq signal's occupied bandwidth;
2. Set the number of counts to a value that stabilizes the measured CCDF curve;
3. Record the maximum PAPR level associated with a probability of 0.1%.

Test Data

GPRS 850 (CH Low)

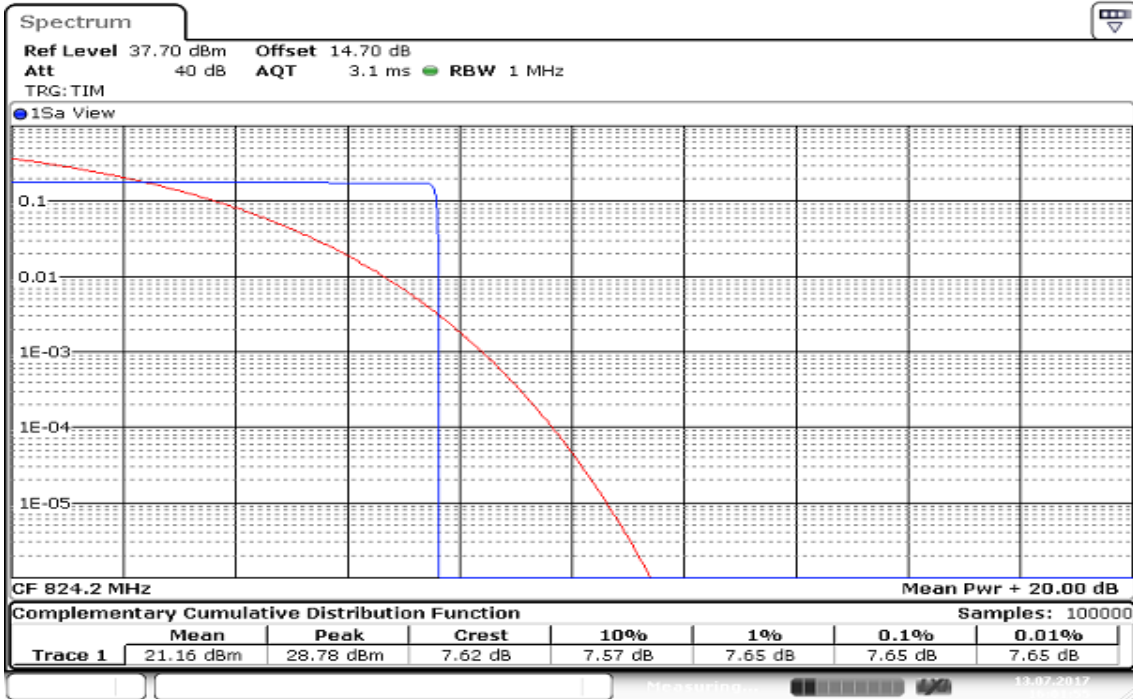

Date: 13.JUL.2017 16:01:54

GPRS 850 (CH Mid)

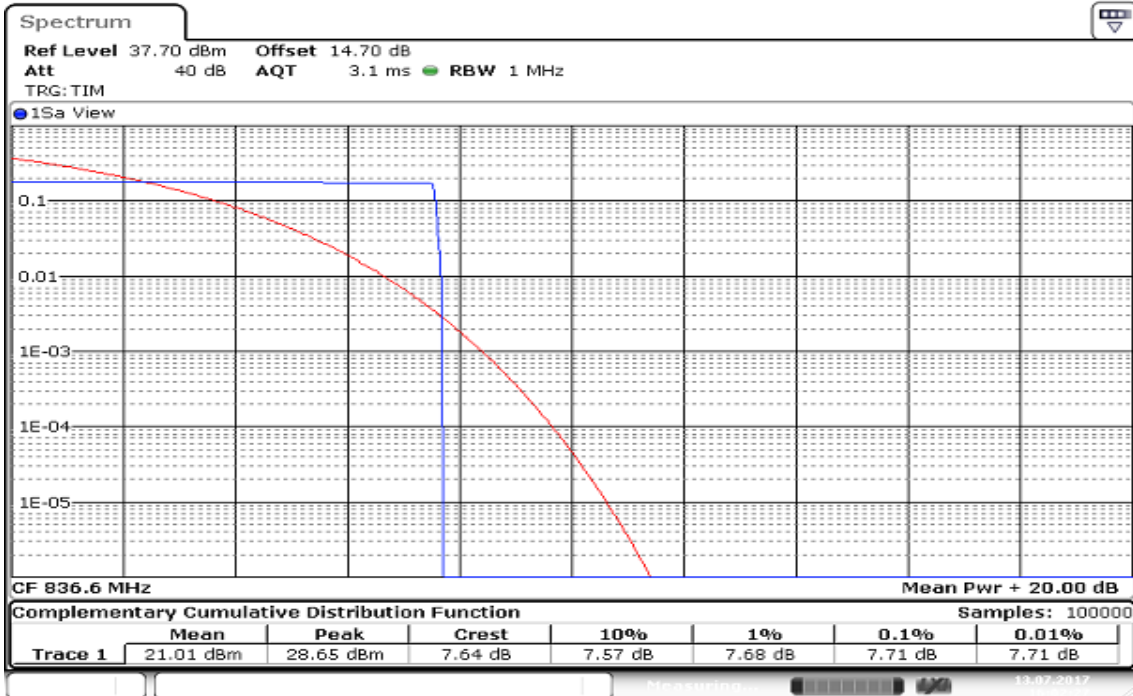

Date: 13.JUL.2017 16:02:27

GPRS 850(CH High)

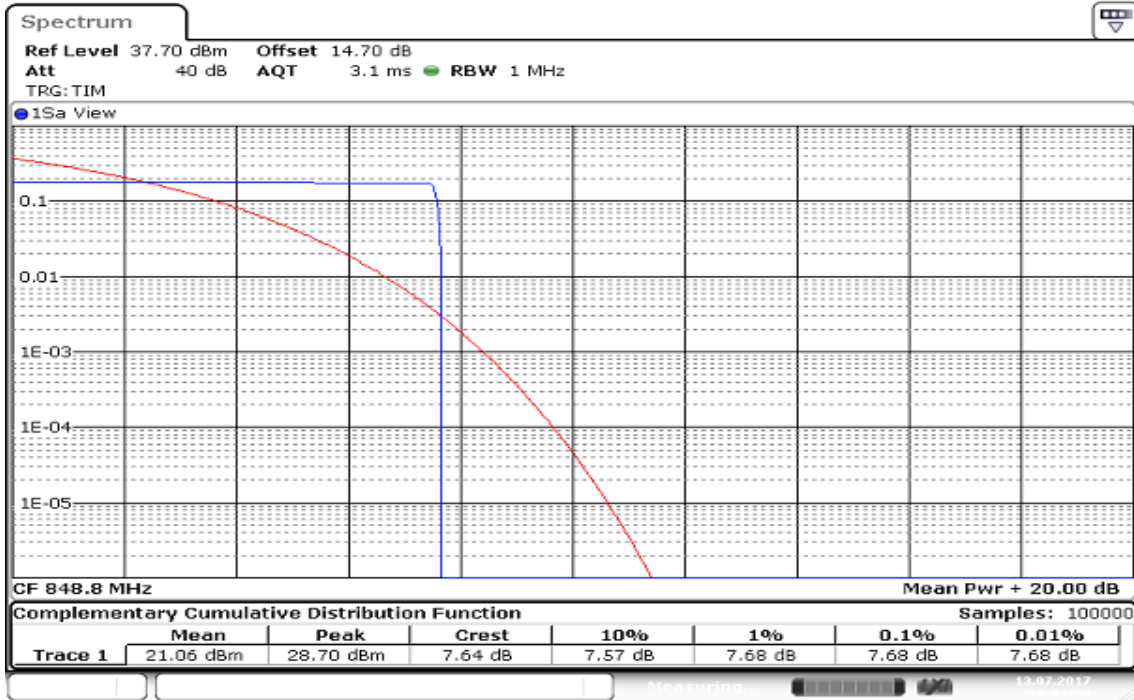

Date: 13.JUL.2017 16:02:59

GPRS 1900

GPRS 1900 (CH Low)

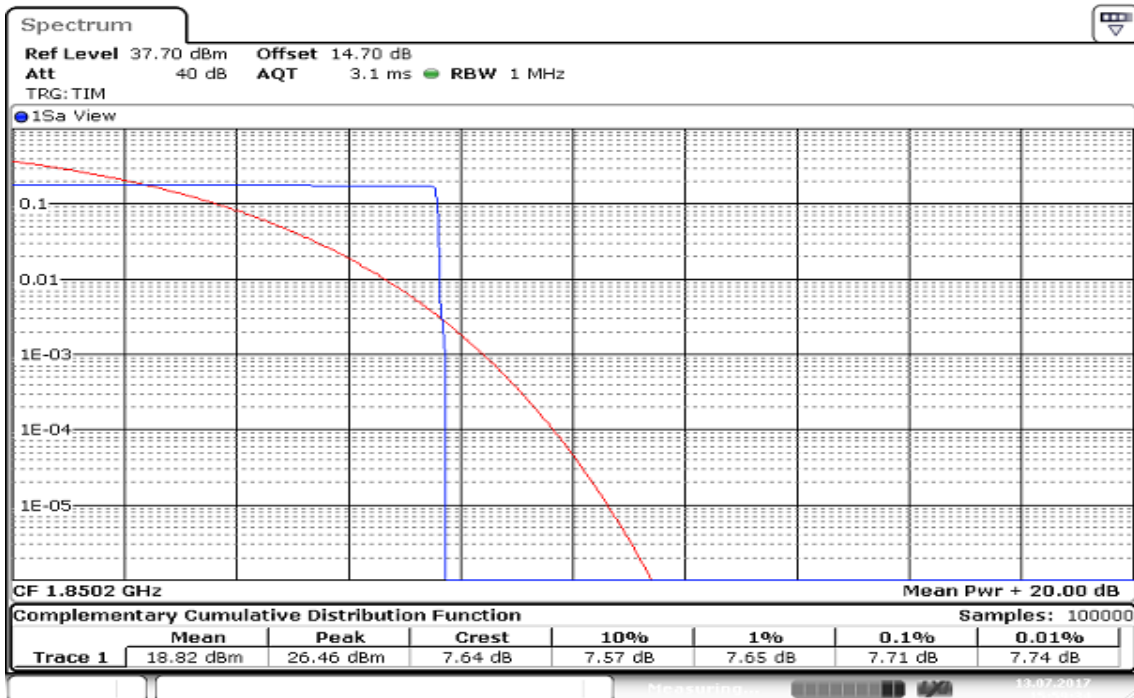

Date: 13.JUL.2017 15:59:33

GPRS 1900 (CH Mid)

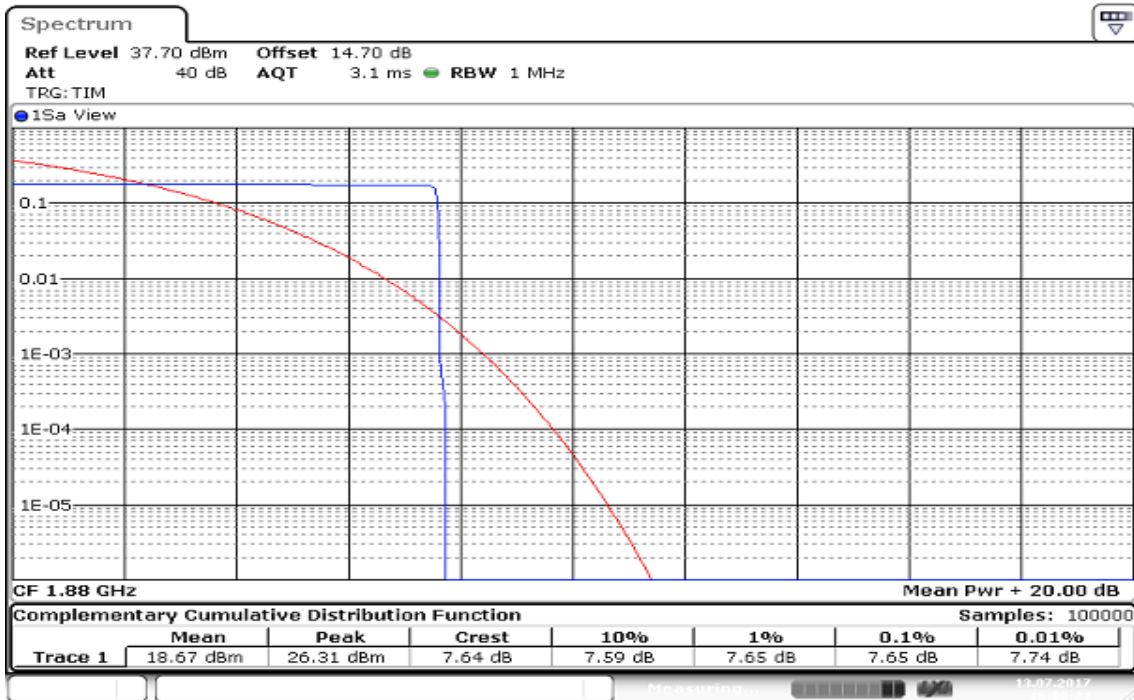

Date: 13.JUL.2017 16:00:23

GPRS 1900 (CH High)

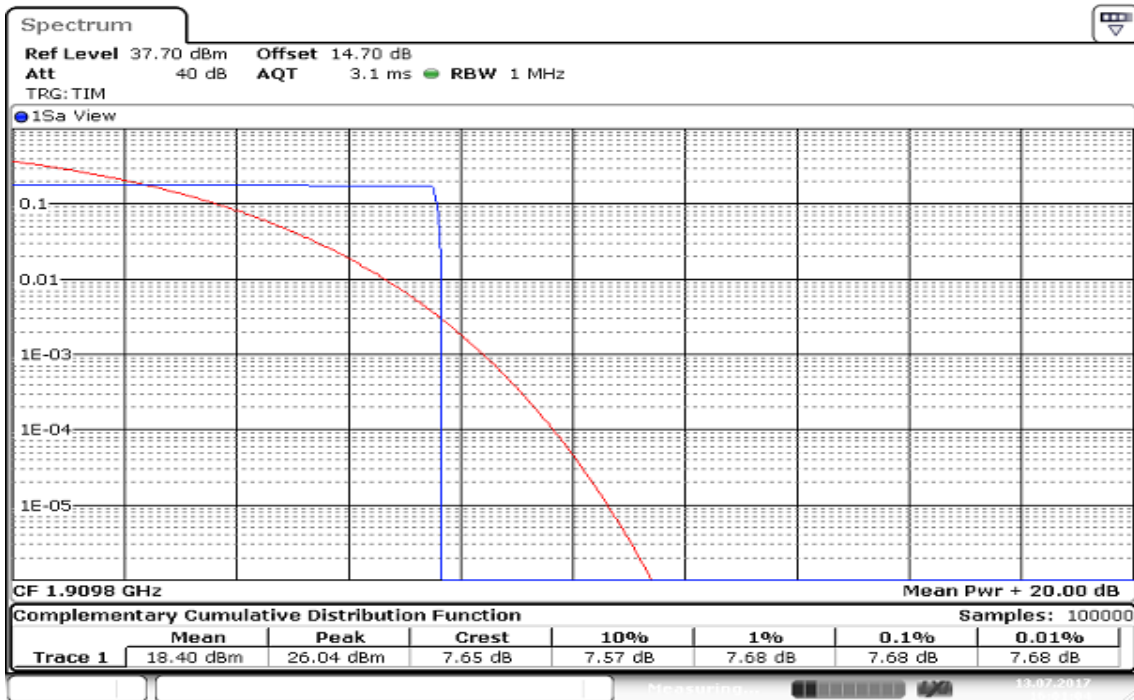

Date: 13.JUL.2017 16:01:04

7.7 FIELD STRENGTH OF SPURIOUS RADIATION MEASUREMENT

LIMIT

According to FCC §2.1053

According to RSS-132 (5.5) & RSS-133 (6.5).

Test Configuration

Below 1 GHz

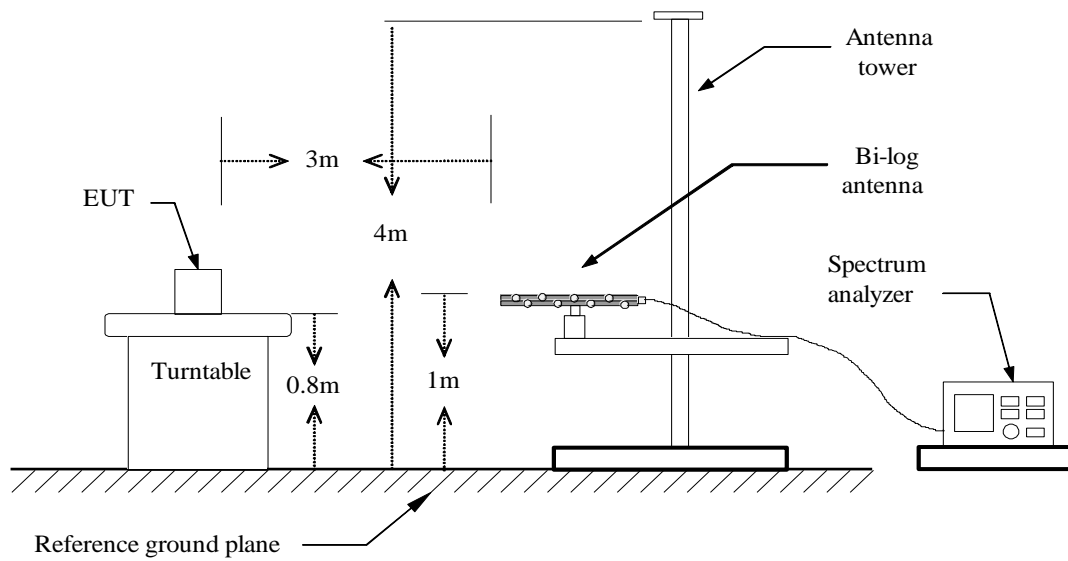

Above 1 GHz

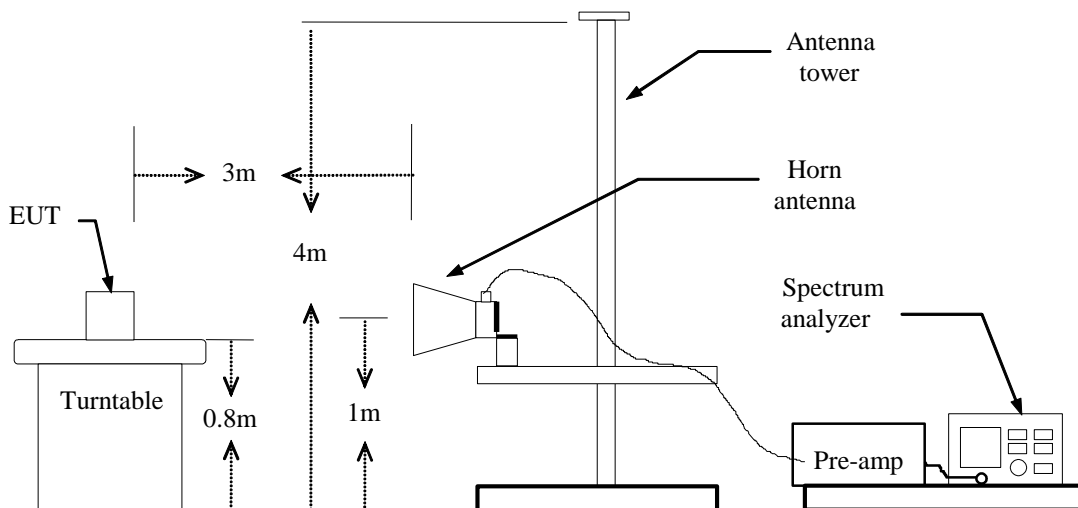

Substituted Method Test Set-up

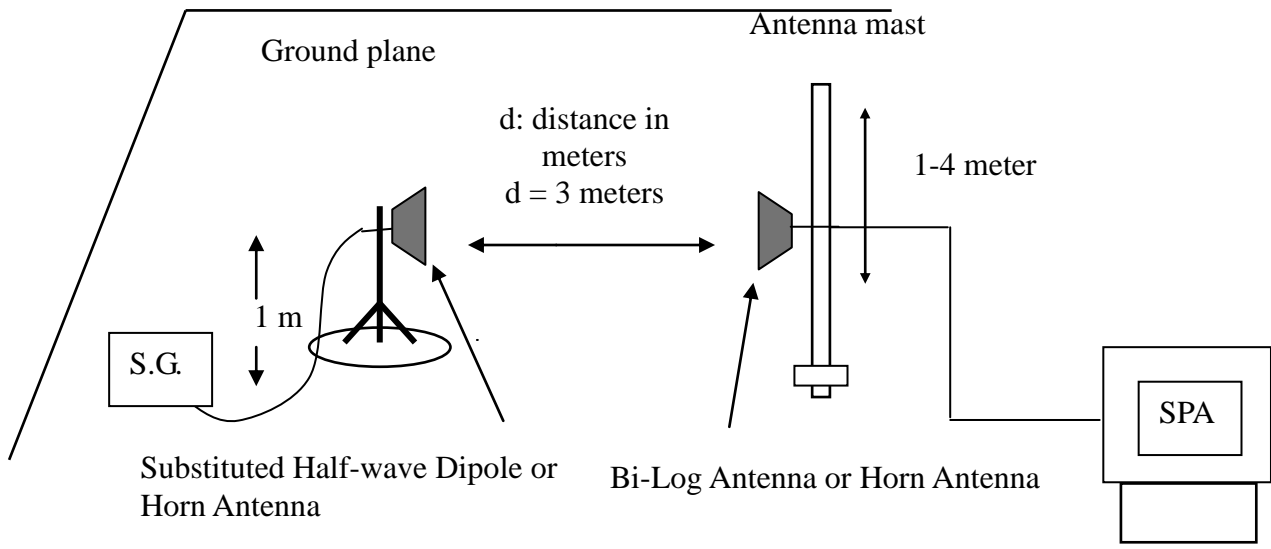

TEST PROCEDURE

The EUT was placed on a non-conductive, the measurement antenna was placed at a distance of 3 meters from the EUT. During the tests, the antenna height and the EUT azimuth were varied in order to identify the maximum level of emissions from the EUT. This maximization process was repeated with the EUT positioned in each of its three orthogonal orientations.

The frequency range up to tenth harmonic was investigated for each of three fundamental frequency (low, middle and high channels). Once spurious emission were identified, the power of the emission was determined using the substitution method.

The spurious emissions attenuation was calculated as the difference between radiated power at the fundamental frequency and the spurious emissions frequency.

$$ERP = \text{S.G. output (dBm)} + \text{Antenna Gain (dBd)} - \text{Cable (dB)}$$

$$EIRP = \text{S.G. output (dBm)} + \text{Antenna Gain (dBi)} - \text{Cable (dB)}$$

TEST RESULTS

Refer to the attached tabular data sheets.

Radiated Spurious Emission Measurement Result / Below 1GHz

Operation Mode: GPRS 850 / TX / CH 190

Test Date: May 11, 2017

Temperature: 22.5°C

Tested by: Timmy Wang

Humidity: 49 % RH

Polarity: Ver.

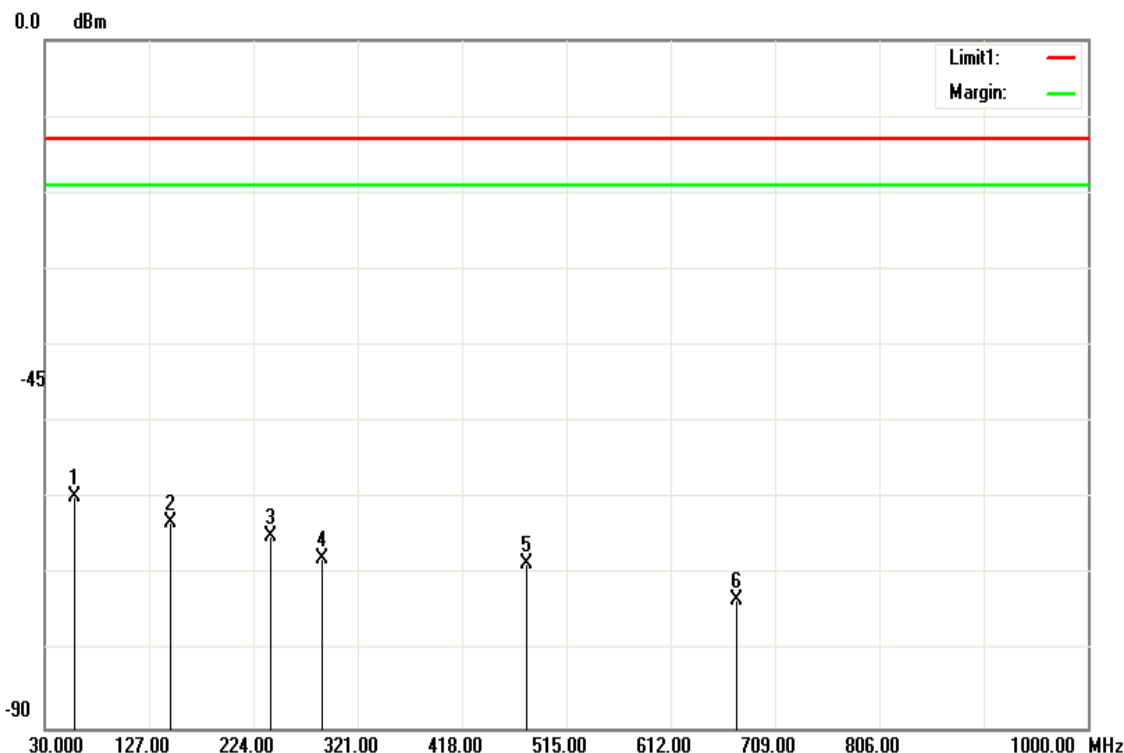

Frequency (MHz)	S.G. (dBm)	Ant.Gain (dBi)	Emission level (dBm)	Limit (dBm)	Margin (dB)	Antenna Polarization (V/H)
57.1600	-58.15	-1.58	-59.73	-13.00	-46.73	V
147.3700	-63.68	0.54	-63.14	-13.00	-50.14	V
239.5200	-71.69	6.71	-64.98	-13.00	-51.98	V
288.0200	-74.84	7.02	-67.82	-13.00	-54.82	V
478.1400	-75.38	6.91	-68.47	-13.00	-55.47	V
673.1100	-74.89	1.64	-73.25	-13.00	-60.25	V

Remark:

1. The emission behaviour belongs to narrowband spurious emission.
2. Measurements above show only up to 6 maximum emissions noted, or would be lesser, with "N/A" remark, if no specific emissions from the EUT are recorded (ie: margin>20dB from the applicable limit) and considered that's already beyond the background noise floor.

Operation Mode: GPRS 850 / TX / CH 190
Temperature: 22.5°C
Humidity: 49 % RH

Test Date: May 11, 2017
Tested by: Timmy Wang
Polarity: Hor.

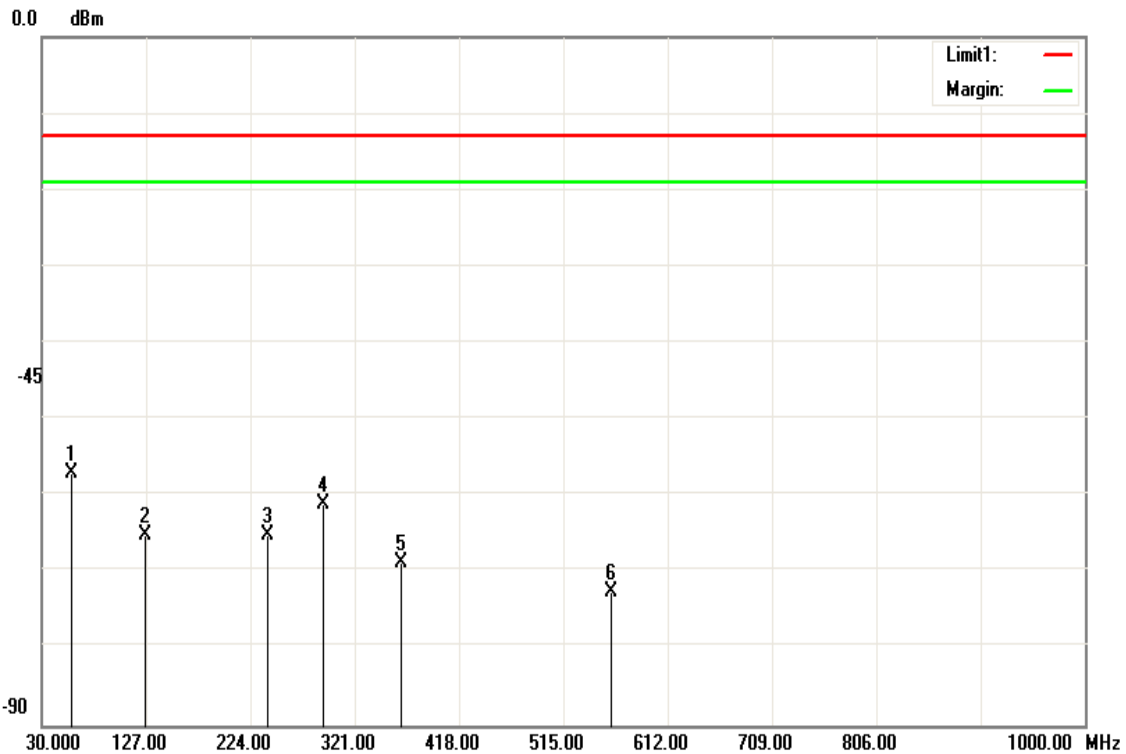

Frequency (MHz)	S.G. (dBm)	Ant.Gain (dBi)	Emission level (dBm)	Limit (dBm)	Margin (dB)	Antenna Polarization (V/H)
57.1600	-55.4	-1.58	-56.98	-13.00	-43.98	H
126.0300	-66.23	0.99	-65.24	-13.00	-52.24	H
239.5200	-71.91	6.71	-65.20	-13.00	-52.20	H
291.9000	-68.02	6.98	-61.04	-13.00	-48.04	H
363.6800	-75.98	7.15	-68.83	-13.00	-55.83	H
559.6200	-77.8	5.23	-72.57	-13.00	-59.57	H

Remark:

1. The emission behaviour belongs to narrowband spurious emission.
2. Measurements above show only up to 6 maximum emissions noted, or would be lesser, with " N/A " remark, if no specific emissions from the EUT are recorded (ie: margin>20dB from the applicable limit) and considered that's already beyond the background noise floor.

Operation Mode: GPRS 1900 / TX / CH 661
Temperature: 22.5°C
Humidity: 49 % RH

Test Date: May 11, 2017
Tested by: Timmy Wang
Polarity: Ver.

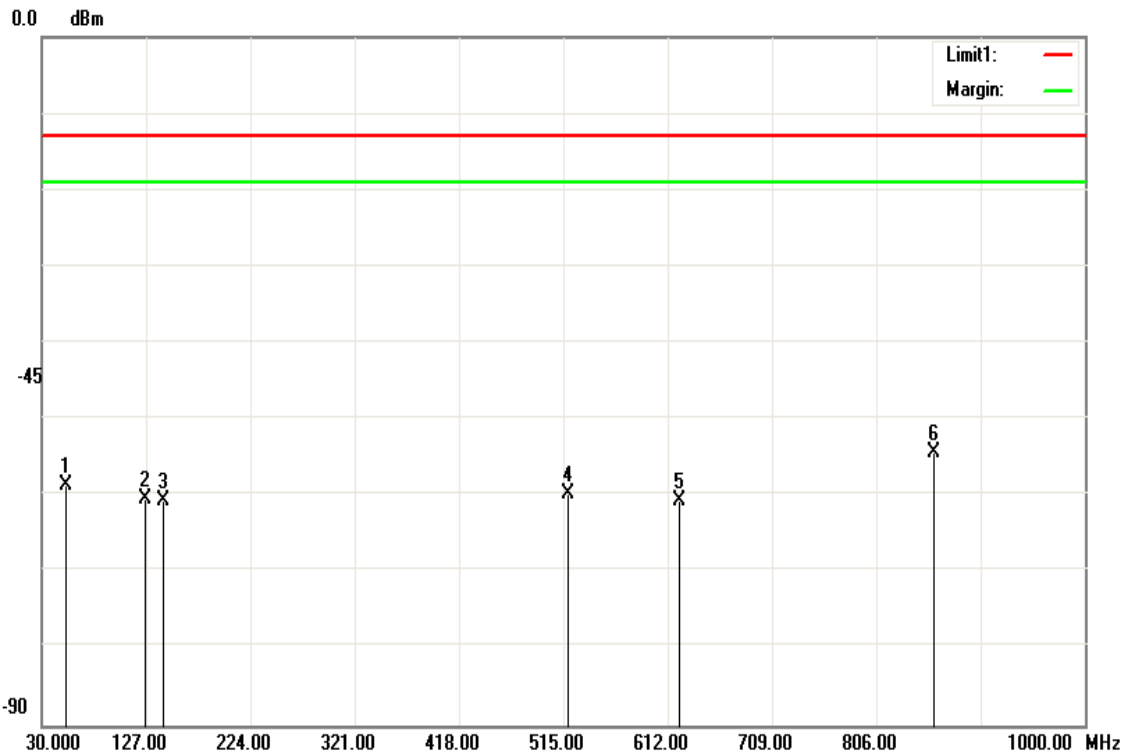

Frequency (MHz)	S.G. (dBm)	Ant.Gain (dBi)	Emission level (dBm)	Limit (dBm)	Margin (dB)	Antenna Polarization (V/H)
52.3100	-56.59	-2.07	-58.66	-13.00	-45.66	V
126.0300	-61.49	0.99	-60.50	-13.00	-47.50	V
143.4900	-61.6	0.89	-60.71	-13.00	-47.71	V
518.8800	-66.54	6.82	-59.72	-13.00	-46.72	V
622.6700	-60.32	-0.28	-60.60	-13.00	-47.60	V
859.3500	-55.47	1.22	-54.25	-13.00	-41.25	V

Remark:

1. Measuring frequencies from 1 GHz to the 10th harmonic of highest fundamental frequency.
2. Measurements above show only up to 6 maximum emissions noted, or would be lesser, with " N/A " remark, if no specific emissions from the EUT are recorded (ie: margin>20dB from the applicable limit) and considered that's already beyond the background noise floor.

Operation Mode: GPRS 1900 / TX / CH 661
Temperature: 22.5°C
Humidity: 49 % RH

Test Date: May 11, 2017
Tested by: Timmy Wang
Polarity: Hor.

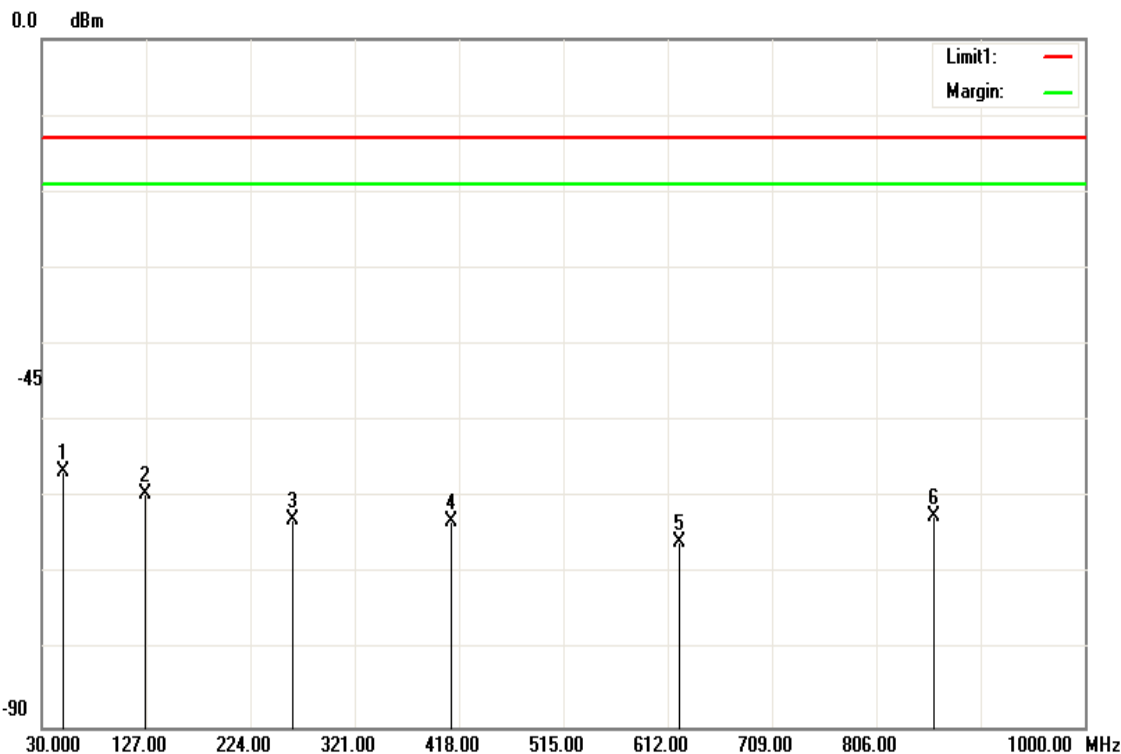

Frequency (MHz)	S.G. (dBm)	Ant.Gain (dBi)	Emission level (dBm)	Limit (dBm)	Margin (dB)	Antenna Polarization (V/H)
50.3700	-54.36	-2.26	-56.62	-13.00	-43.62	H
126.0300	-60.57	0.99	-59.58	-13.00	-46.58	H
262.8000	-70.08	7.27	-62.81	-13.00	-49.81	H
411.2100	-70.38	7.24	-63.14	-13.00	-50.14	H
622.6700	-65.6	-0.28	-65.88	-13.00	-52.88	H
859.3500	-63.67	1.22	-62.45	-13.00	-49.45	H

Remark:

1. Measuring frequencies from 1 GHz to the 10th harmonic of highest fundamental frequency.
2. Measurements above show only up to 6 maximum emissions noted, or would be lesser, with " N/A " remark, if no specific emissions from the EUT are recorded (ie: margin>20dB from the applicable limit) and considered that's already beyond the background noise floor.

Above 1GHz

Operation Mode: GPRS 850 / TX / CH 128

Test Date: May 11, 2017

Temperature: 22.5°C

Tested by: Timmy Wang

Humidity: 49 % RH

Polarity: Ver.

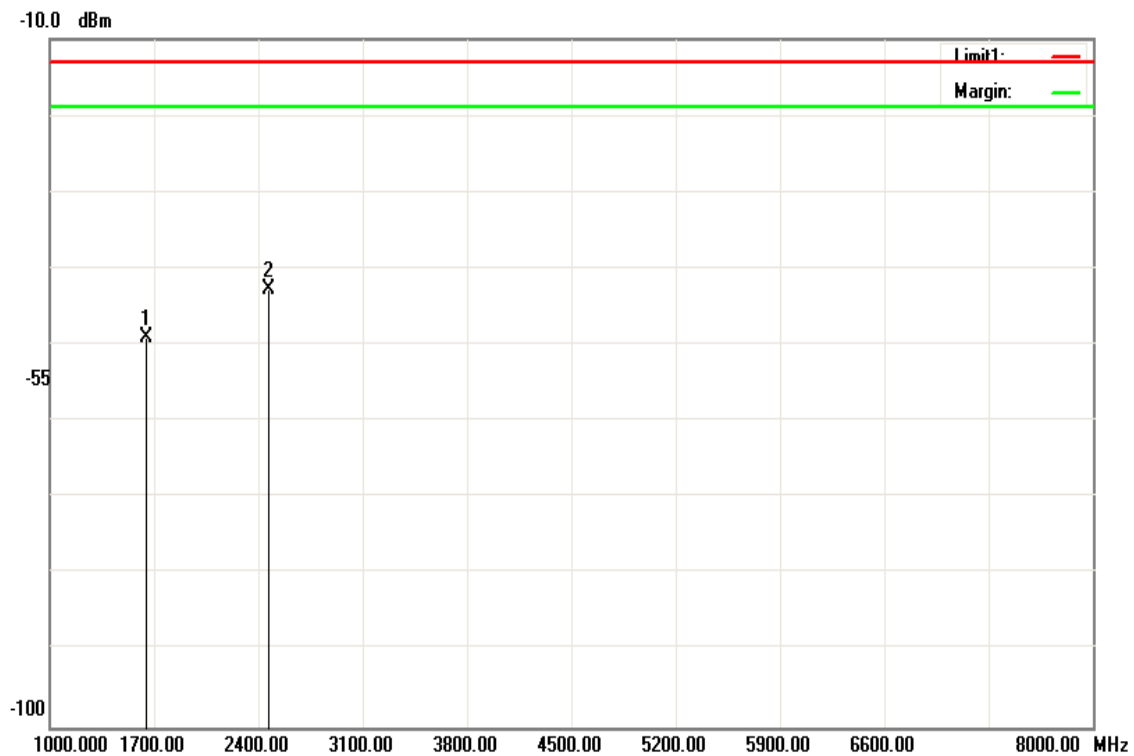

Frequency (MHz)	S.G. (dBm)	Ant.Gain (dBi)	Emission level (dBm)	Limit (dBm)	Margin (dB)	Antenna Polarization (V/H)
1651.000	-50.5	1.52	-48.98	-13.00	-35.98	V
2470.000	-44.52	1.83	-42.69	-13.00	-29.69	V
N/A						

Remark:

1. The emission behaviour belongs to narrowband spurious emission.
2. Measurements above show only up to 6 maximum emissions noted, or would be lesser, with " N/A " remark, if no specific emissions from the EUT are recorded (ie: margin>20dB from the applicable limit) and considered that's already beyond the background noise floor.

Operation Mode: GPRS 850 / TX / CH 128
Temperature: 22.5°C
Humidity: 49 % RH

Test Date: May 11, 2017
Tested by: Timmy Wang
Polarity: Hor.

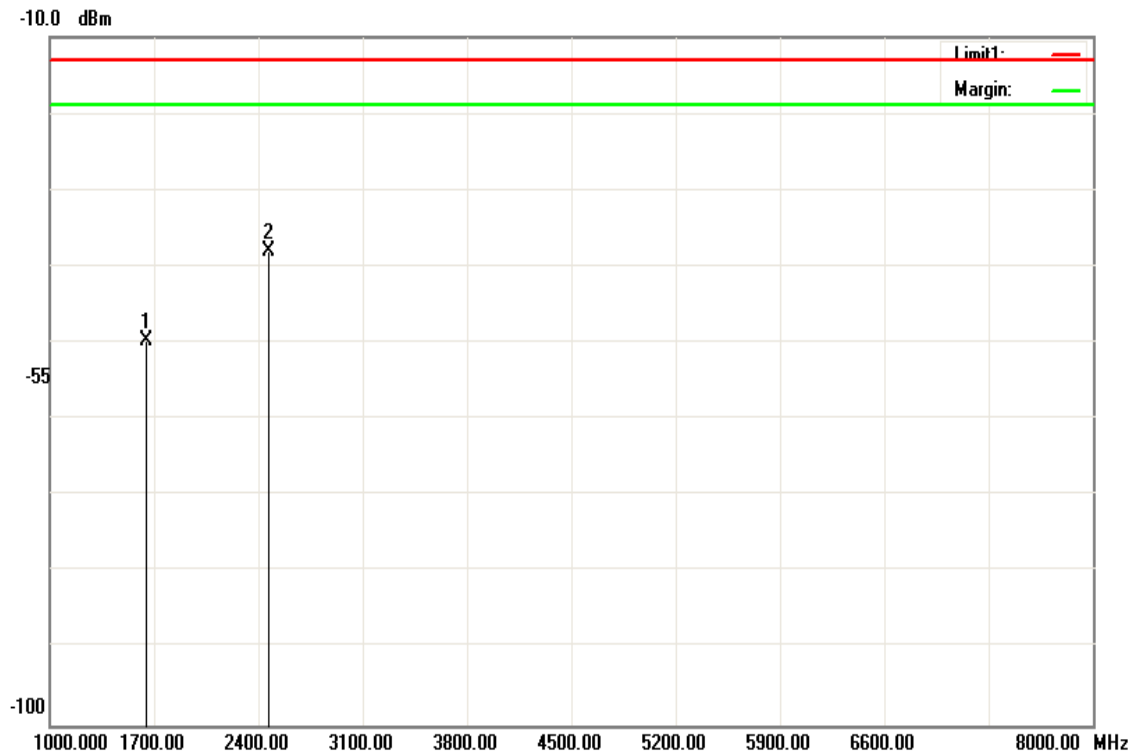

Frequency (MHz)	S.G. (dBm)	Ant.Gain (dBi)	Emission level (dBm)	Limit (dBm)	Margin (dB)	Antenna Polarization (V/H)
1651.000	-51.17	1.52	-49.65	-13.00	-36.65	H
2470.000	-39.77	1.83	-37.94	-13.00	-24.94	H
N/A						

Remark:

1. The emission behaviour belongs to narrowband spurious emission.
2. Measurements above show only up to 6 maximum emissions noted, or would be lesser, with " N/A " remark, if no specific emissions from the EUT are recorded (ie: margin>20dB from the applicable limit) and considered that's already beyond the background noise floor.

Operation Mode: GPRS 850 / TX / CH 190
Temperature: 22.5°C
Humidity: 49 % RH

Test Date: May 11, 2017
Tested by: Timmy Wang
Polarity: Ver.

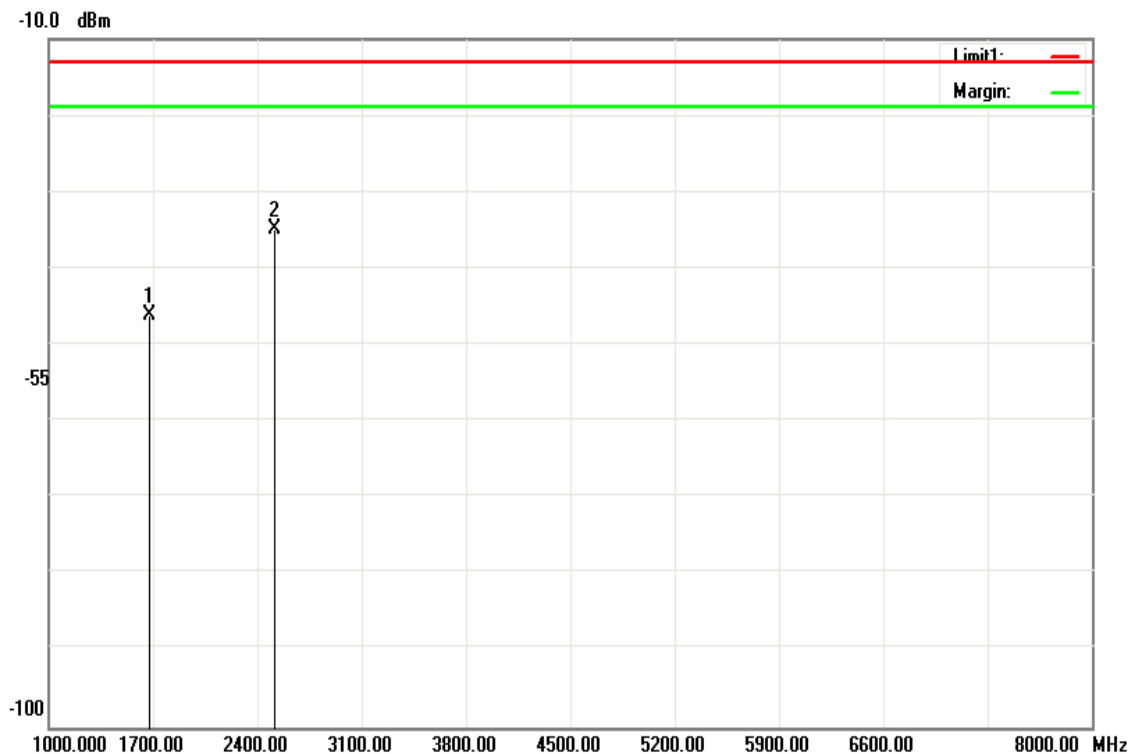

Frequency (MHz)	S.G. (dBm)	Ant.Gain (dBi)	Emission level (dBm)	Limit (dBm)	Margin (dB)	Antenna Polarization (V/H)
1672.000	-47.52	1.52	-46.00	-13.00	-33.00	V
2512.000	-37.04	2.07	-34.97	-13.00	-21.97	V
N/A						

Remark:

1. The emission behaviour belongs to narrowband spurious emission.
2. Measurements above show only up to 6 maximum emissions noted, or would be lesser, with " N/A " remark, if no specific emissions from the EUT are recorded (ie: margin>20dB from the applicable limit) and considered that's already beyond the background noise floor.

Operation Mode: GPRS 850 / TX / CH 190
Temperature: 22.5°C
Humidity: 49 % RH

Test Date: May 11, 2017
Tested by: Timmy Wang
Polarity: Hor.

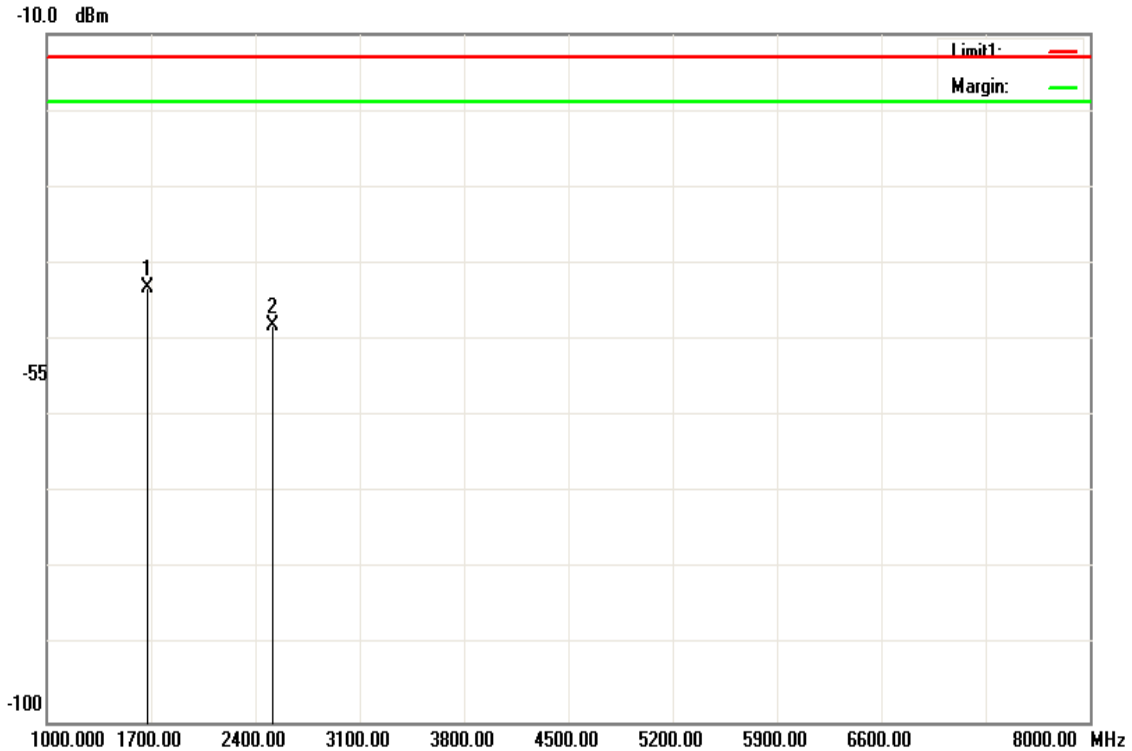

Frequency (MHz)	S.G. (dBm)	Ant.Gain (dBi)	Emission level (dBm)	Limit (dBm)	Margin (dB)	Antenna Polarization (V/H)
1672.000	-44.6	1.52	-43.08	-13.00	-30.08	H
2512.000	-50.21	2.07	-48.14	-13.00	-35.14	H
N/A						

Remark:

1. The emission behaviour belongs to narrowband spurious emission.
2. Measurements above show only up to 6 maximum emissions noted, or would be lesser, with " N/A " remark, if no specific emissions from the EUT are recorded (ie: margin>20dB from the applicable limit) and considered that's already beyond the background noise floor.

Operation Mode: GPRS 850 / TX / CH 251
Temperature: 22.5°C
Humidity: 49 % RH

Test Date: May 11, 2017
Tested by: Timmy Wang
Polarity: Ver.

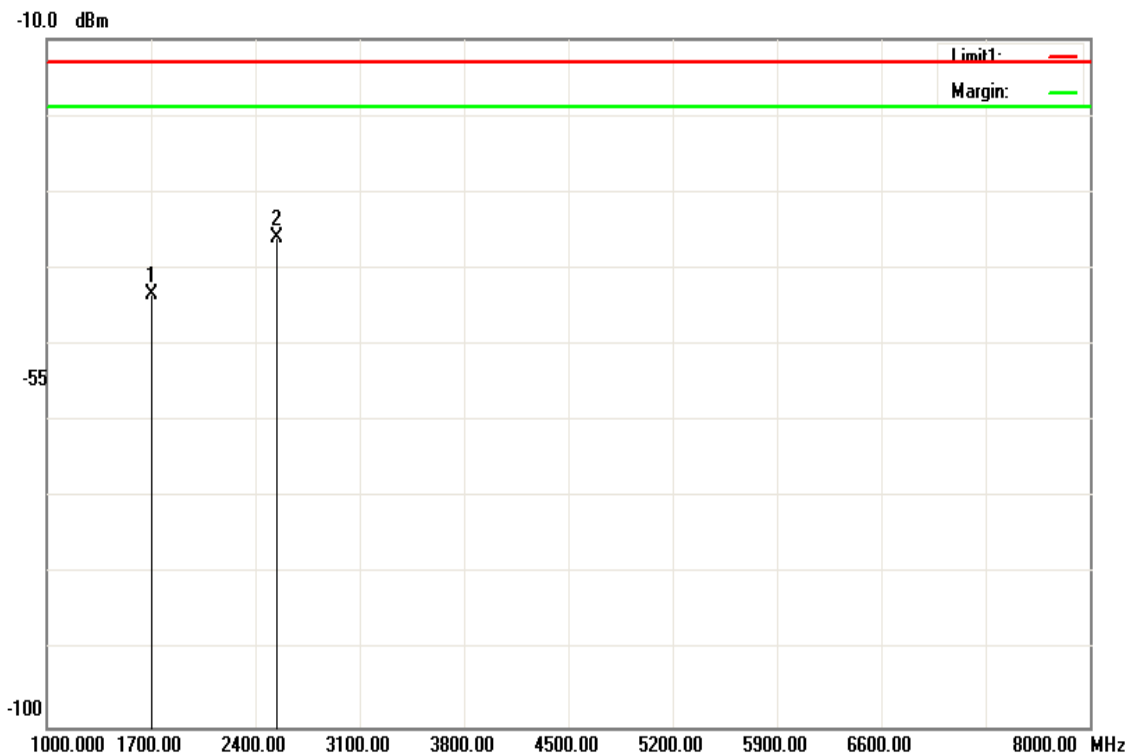

Frequency (MHz)	S.G. (dBm)	Ant.Gain (dBi)	Emission level (dBm)	Limit (dBm)	Margin (dB)	Antenna Polarization (V/H)
1700.000	-44.96	1.51	-43.45	-13.00	-30.45	V
2547.000	-38.77	2.73	-36.04	-13.00	-23.04	V
N/A						

Remark:

1. The emission behaviour belongs to narrowband spurious emission.
2. Measurements above show only up to 6 maximum emissions noted, or would be lesser, with " N/A " remark, if no specific emissions from the EUT are recorded (ie: margin>20dB from the applicable limit) and considered that's already beyond the background noise floor.

Operation Mode: GPRS 850 / TX / CH 251
Temperature: 22.5°C
Humidity: 49 % RH

Test Date: May 11, 2017
Tested by: Timmy Wang
Polarity: Hor.

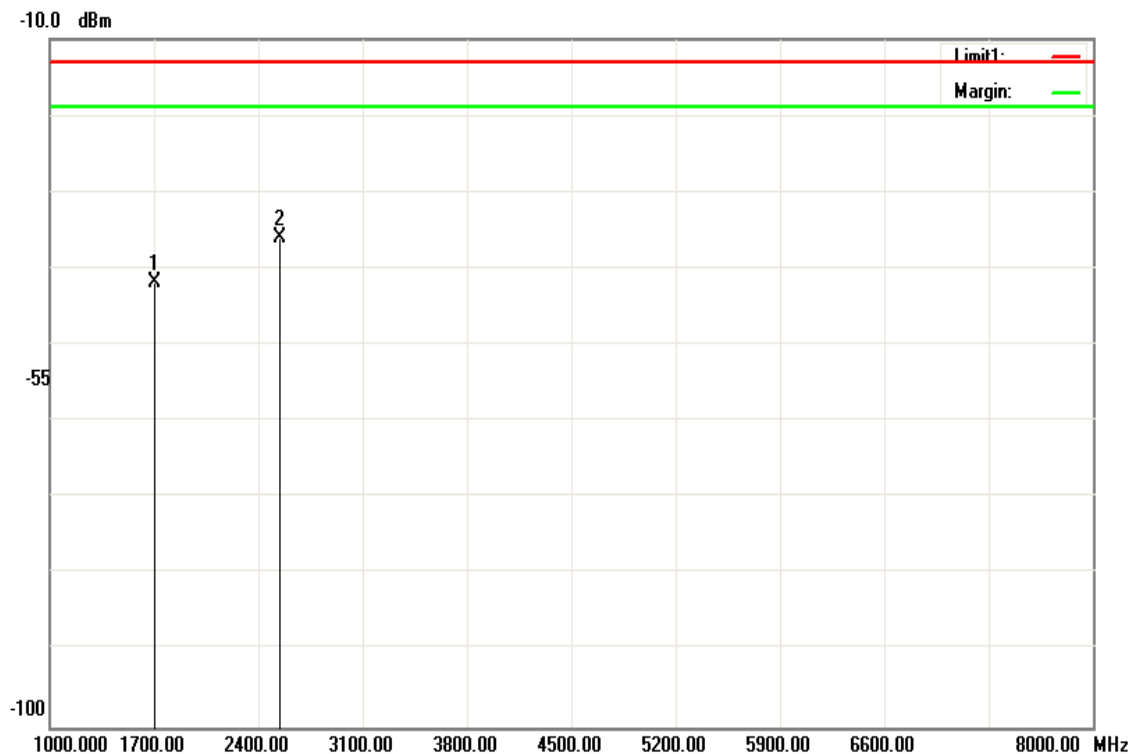

Frequency (MHz)	S.G. (dBm)	Ant.Gain (dBi)	Emission level (dBm)	Limit (dBm)	Margin (dB)	Antenna Polarization (V/H)
1700.000	-43.37	1.51	-41.86	-13.00	-28.86	H
2547.000	-38.79	2.73	-36.06	-13.00	-23.06	H
N/A						

Remark:

1. The emission behaviour belongs to narrowband spurious emission.
2. Measurements above show only up to 6 maximum emissions noted, or would be lesser, with " N/A " remark, if no specific emissions from the EUT are recorded (ie: margin>20dB from the applicable limit) and considered that's already beyond the background noise floor.

Operation Mode: GPRS 1900 / TX / CH 512
Temperature: 22.5°C
Humidity: 49 % RH

Test Date: May 11, 2017
Tested by: Timmy Wang
Polarity: Ver.

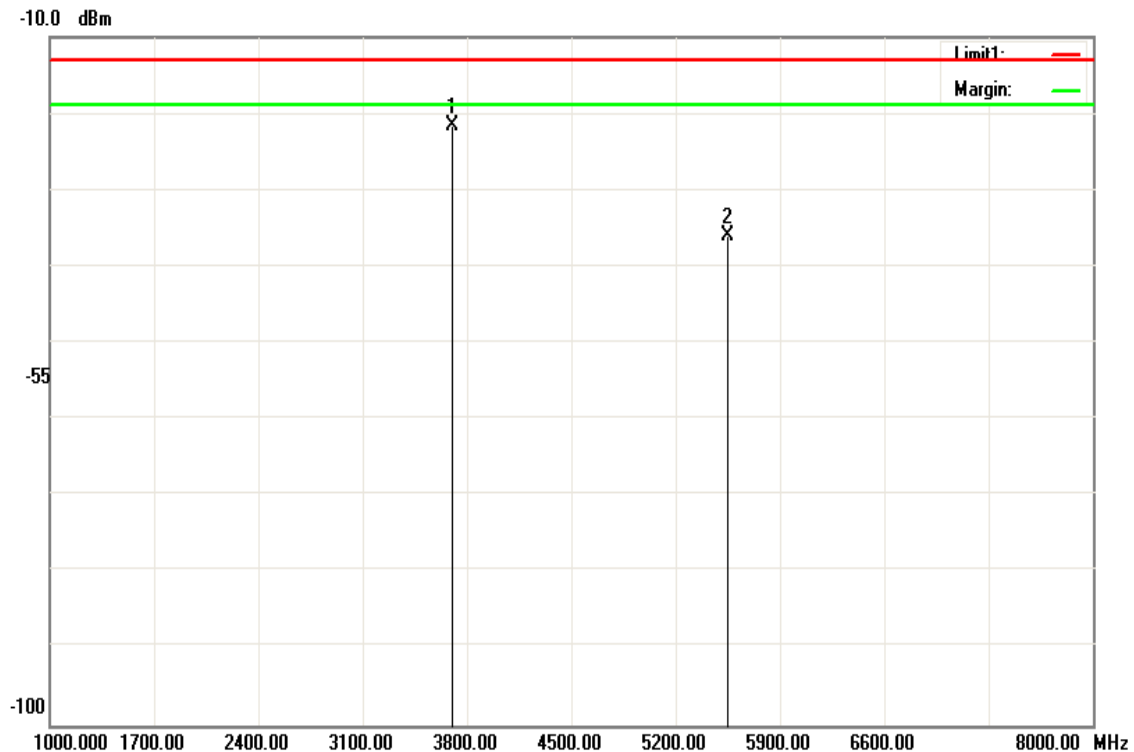

Frequency (MHz)	S.G. (dBm)	Ant.Gain (dBi)	Emission level (dBm)	Limit (dBm)	Margin (dB)	Antenna Polarization (V/H)
3702.000	-34.23	12.54	-21.69	-13.00	-8.69	V
5550.000	-48.81	12.88	-35.93	-13.00	-22.93	V
N/A						

Remark:

1. Measuring frequencies from 1 GHz to the 10th harmonic of highest fundamental frequency.
2. Measurements above show only up to 6 maximum emissions noted, or would be lesser, with " N/A " remark, if no specific emissions from the EUT are recorded (ie: margin>20dB from the applicable limit) and considered that's already beyond the background noise floor.

Operation Mode: GPRS 1900 / TX / CH 512
Temperature: 22.5°C
Humidity: 49 % RH

Test Date: May 11, 2017
Tested by: Timmy Wang
Polarity: Hor.

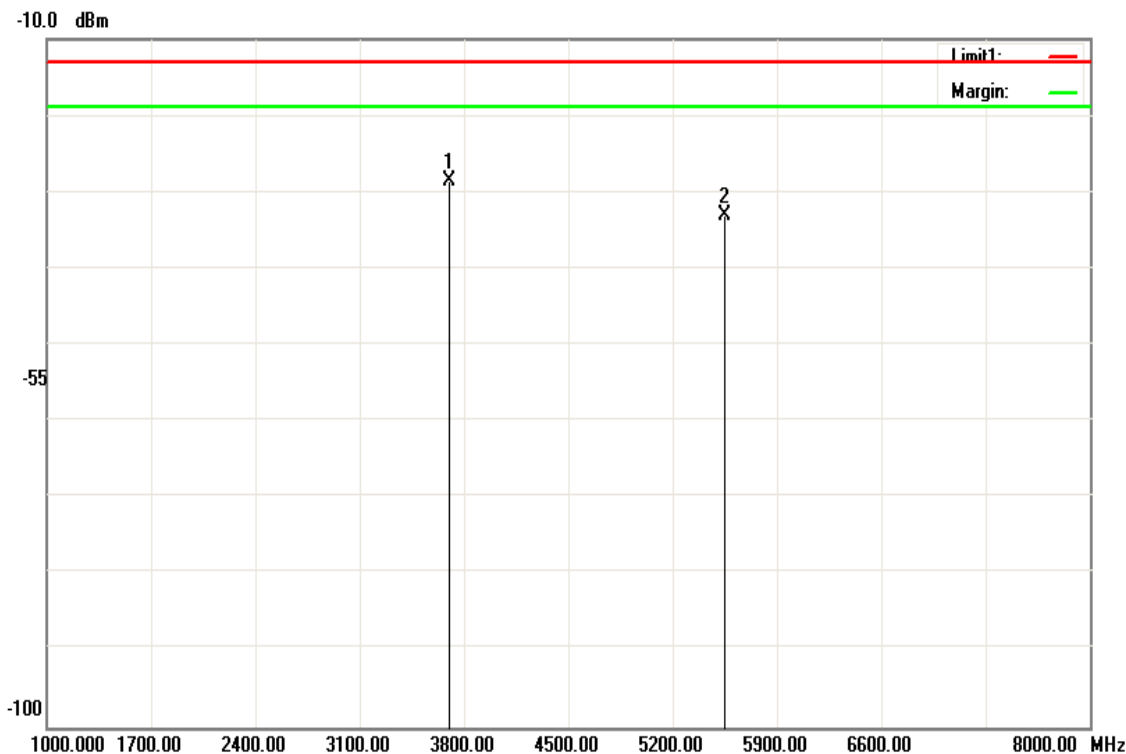

Frequency (MHz)	S.G. (dBm)	Ant.Gain (dBi)	Emission level (dBm)	Limit (dBm)	Margin (dB)	Antenna Polarization (V/H)
3702.000	-41.18	12.54	-28.64	-13.00	-15.64	H
5550.000	-46	12.88	-33.12	-13.00	-20.12	H
N/A						

Remark:

1. Measuring frequencies from 1 GHz to the 10th harmonic of highest fundamental frequency.
2. Measurements above show only up to 6 maximum emissions noted, or would be lesser, with " N/A " remark, if no specific emissions from the EUT are recorded (ie: margin>20dB from the applicable limit) and considered that's already beyond the background noise floor.

Operation Mode: GPRS 1900 / TX / CH 661
Temperature: 22.5°C
Humidity: 49 % RH

Test Date: May 11, 2017
Tested by: Timmy Wang
Polarity: Ver.



Frequency (MHz)	S.G. (dBm)	Ant.Gain (dBi)	Emission level (dBm)	Limit (dBm)	Margin (dB)	Antenna Polarization (V/H)
3758.000	-43.92	12.55	-31.37	-13.00	-18.37	V
5641.000	-44.75	12.84	-31.91	-13.00	-18.91	V
N/A						

Remark:

1. Measuring frequencies from 1 GHz to the 10th harmonic of highest fundamental frequency.
2. Measurements above show only up to 6 maximum emissions noted, or would be lesser, with " N/A " remark, if no specific emissions from the EUT are recorded (ie: margin>20dB from the applicable limit) and considered that's already beyond the background noise floor.

Operation Mode: GPRS 1900 / TX / CH 661
Temperature: 22.5°C
Humidity: 49 % RH

Test Date: May 11, 2017
Tested by: Timmy Wang
Polarity: Hor.

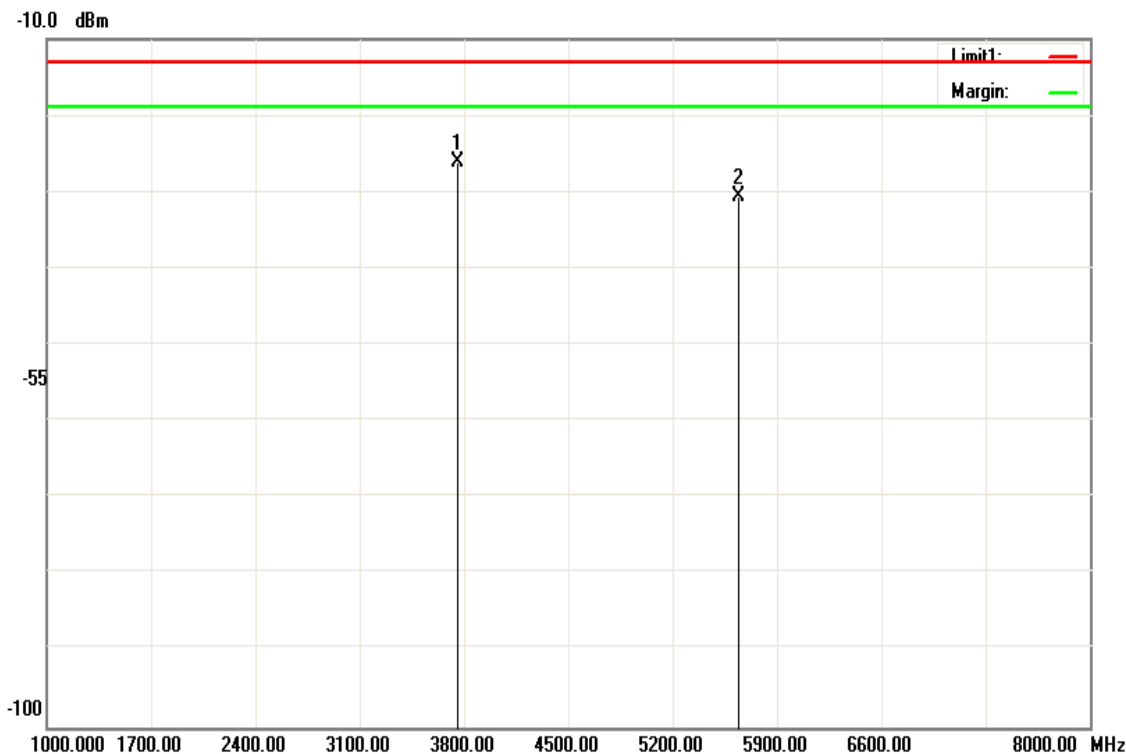

Frequency (MHz)	S.G. (dBm)	Ant.Gain (dBi)	Emission level (dBm)	Limit (dBm)	Margin (dB)	Antenna Polarization (V/H)
3758.000	-38.6	12.55	-26.05	-13.00	-13.05	H
5641.000	-43.53	12.84	-30.69	-13.00	-17.69	H
N/A						

Remark:

1. Measuring frequencies from 1 GHz to the 10th harmonic of highest fundamental frequency.
2. Measurements above show only up to 6 maximum emissions noted, or would be lesser, with " N/A " remark, if no specific emissions from the EUT are recorded (ie: margin>20dB from the applicable limit) and considered that's already beyond the background noise floor.

Operation Mode: GPRS 1900 / TX / CH 810
Temperature: 22.5°C
Humidity: 49 % RH

Test Date: May 11, 2017
Tested by: Timmy Wang
Polarity: Ver.



Frequency (MHz)	S.G. (dBm)	Ant.Gain (dBi)	Emission level (dBm)	Limit (dBm)	Margin (dB)	Antenna Polarization (V/H)
3821.000	-42.28	12.56	-29.72	-13.00	-16.72	V
5732.000	-42.2	12.81	-29.39	-13.00	-16.39	V
N/A						

Remark:

1. Measuring frequencies from 1 GHz to the 10th harmonic of highest fundamental frequency.
2. Measurements above show only up to 6 maximum emissions noted, or would be lesser, with " N/A " remark, if no specific emissions from the EUT are recorded (ie: margin>20dB from the applicable limit) and considered that's already beyond the background noise floor.

Operation Mode: GPRS 1900 / TX / CH 810
Temperature: 22.5°C
Humidity: 49 % RH

Test Date: May 11, 2017
Tested by: Timmy Wang
Polarity: Hor.

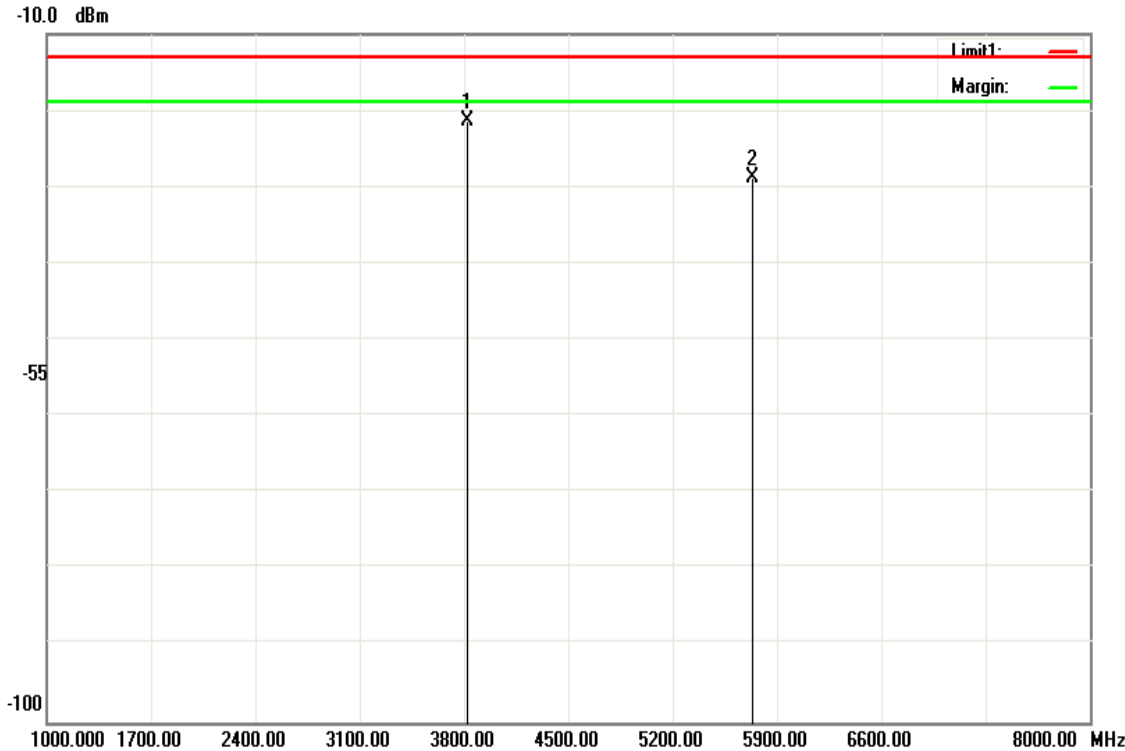

Frequency (MHz)	S.G. (dBm)	Ant.Gain (dBi)	Emission level (dBm)	Limit (dBm)	Margin (dB)	Antenna Polarization (V/H)
3821.000	-33.88	12.56	-21.32	-13.00	-8.32	H
5732.000	-41.54	12.81	-28.73	-13.00	-15.73	H
N/A						

Remark:

1. Measuring frequencies from 1 GHz to the 10th harmonic of highest fundamental frequency.
2. Measurements above show only up to 6 maximum emissions noted, or would be lesser, with " N/A " remark, if no specific emissions from the EUT are recorded (ie: margin>20dB from the applicable limit) and considered that's already beyond the background noise floor.

7.8 FREQUENCY STABILITY V.S. TEMPERATURE MEASUREMENT

LIMIT

According to RSS-132 (5.3) & RSS-133 (6.3).

Frequency Tolerance: 2.5 ppm

Test Configuration

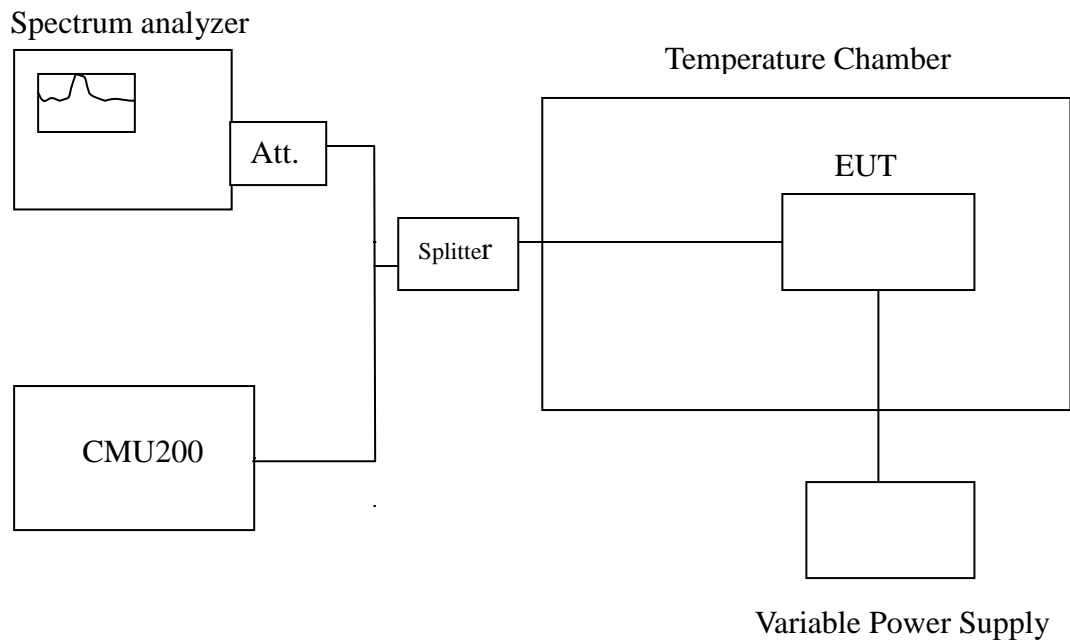

Remark: Measurement setup for testing on Antenna connector

TEST PROCEDURE

The equipment under test was connected to an external AC or DC power supply and input rated voltage. RF output was connected to a frequency counter or spectrum analyzer via feed through attenuators. The EUT was placed inside the temperature chamber. Set the spectrum analyzer RBW low enough to obtain the desired frequency resolution and measure EUT 20°C operating frequency as reference frequency. Turn EUT off and set the chamber temperature to -30°C. After the temperature stabilized for approximately 30 minutes recorded the frequency. Repeat step measure with 10°C increased per stage until the highest temperature of +50°C reached.

TEST RESULTS

No non-compliance noted.

Reference Frequency: GPRS Mid Channel 836.6 MHz @ 20°C				
Limit: +/- 2.5 ppm = 2091.5 Hz				
Power Supply Vdc	Environment Temperature (°C)	Frequency (Hz)	Frequency Error (ppm)	Limit (ppm)
120	50	7	0.008367	2.5
	40	4	0.004781	
	30	1	0.001195	
	20	0	0.000000	
	10	-2	-0.002391	
	0	2	0.002391	
	-10	1	0.001195	
	-20	-2	-0.002391	

Reference Frequency: GPRS Mid Channel 1880 MHz @ 20°C				
Limit: ± 2.5 ppm = 4700 Hz				
Power Supply Vdc	Environment Temperature (°C)	Frequency (Hz)	Frequency Error (ppm)	Limit (ppm)
120	50	10	0.005319	2.5
	40	8	0.004255	
	30	4	0.002128	
	20	5	0.002660	
	10	1	0.000532	
	0	8	0.004255	
	-10	9	0.004787	
	-20	1	0.000532	

7.9 FREQUENCY STABILITY V.S. VOLTAGE MEASUREMENT

LIMIT

According to RSS-132 (4.3) & RSS-133 (6.3).

The carrier frequency shall not depart from the reference frequency in excess of ± 2.5 ppm for mobile stations and ± 1.0 ppm for base stations.

Test Configuration

Spectrum analyzer

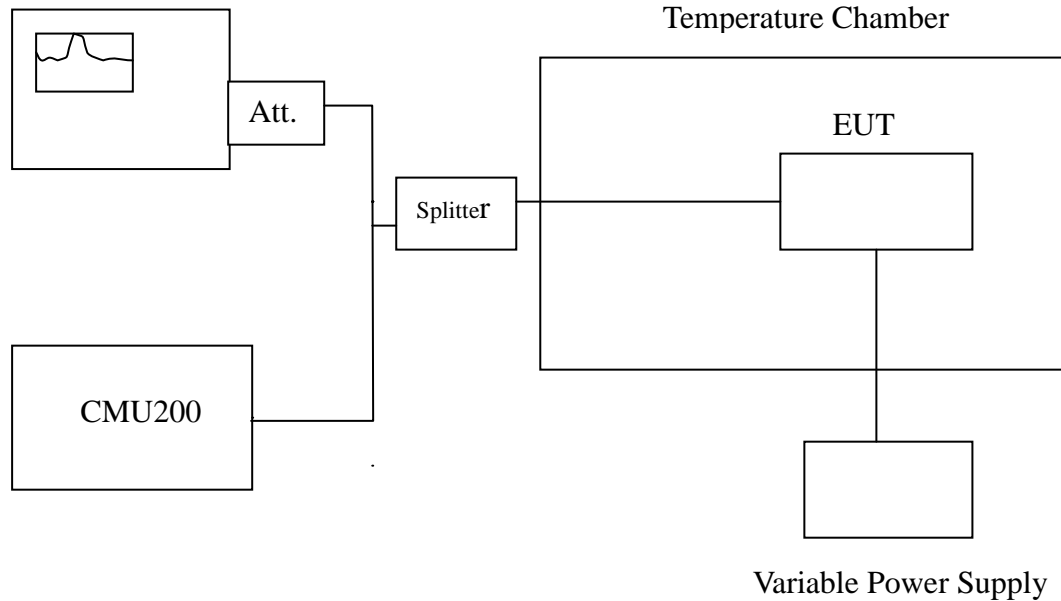

Remark: Measurement setup for testing on Antenna connector.

TEST PROCEDURE

Set chamber temperature to 20°C. Use a variable AC power supply / DC power source to power the EUT and set the voltage to rated voltage. Set the spectrum analyzer RBW low enough to obtain the desired frequency resolution and recorded the frequency.

Reduce the input voltage to specify extreme voltage variation ($\pm 15\%$) and endpoint, record the maximum frequency change.

TEST RESULTS

No non-compliance noted.

Reference Frequency: GPRS Mid Channel 836.6 MHz @ 20°C				
Limit: ± 2.5 ppm = 2091.5Hz				
Power Supply Vdc	Environment Temperature (°C)	Frequency (Hz)	Delta (ppm)	Limit (ppm)
102	20	2	0.002391	2.5
120		4	0.004781	
138		3	0.003586	

Reference Frequency: GPRS Mid Channel 1880 MHz @ 20°C				
Limit: ± 2.5 ppm = 4700 Hz				
Power Supply Vdc	Environment Temperature (°C)	Frequency (Hz)	Delta (ppm)	Limit (ppm)
102	20	4	0.002128	2.5
120		3	0.001596	
138		1	0.000532	