

# FCC Radio Test Report

## FCC ID: M82-AIM10W

This report concerns: Original Grant

**Project No.** : 1710083  
**Equipment** : Computer  
**Test Model** : AIM-10W  
**Series Model** : AIM-10WXXXXXXXXXXXXXXXXXX  
(where X may be any alphanumeric character , blank or "-".)  
**Applicant** : Advantech Co., Ltd.  
**Address** : No.1, Alley 20, Lane 26, Rueiguang Road, Neihu District, Taipei 11491, Taiwan, R.O.C.

**Date of Receipt** : Nov. 13, 2017  
**Date of Test** : Nov. 13, 2017 ~ Feb. 27, 2018  
**Issued Date** : Mar. 01, 2018  
**Tested by** : BTL Inc.

**Technical Manager** :   
(James Chiu)

**Authorized Signatory** :   
(Sean Chen)

# B T L I N C .

No.18, Ln. 171, Sec. 2, Jiuzong Rd.,  
Neihu Dist., Taipei City 114, Taiwan (R.O.C.)  
TEL: +886-2-2657-3299 FAX: +886-2-2657-3331



### **Declaration**

**BTL** represents to the client that testing is done in accordance with standard procedures as applicable and that test instruments used has been calibrated with standards traceable to international standard(s) and/or national standard(s).

**BTL's** reports apply only to the specific samples tested under conditions. It is manufacture's responsibility to ensure that additional production units of this model are manufactured with the identical electrical and mechanical components. **BTL** shall have no liability for any declarations, inferences or generalizations drawn by the client or others from **BTL** issued reports.

**BTL's** report must not be used by the client to claim product certification, approval, or endorsement by NVLAP, NIST, or any agency of the Federal Government.

This report is the confidential property of the client. As a mutual protection to the clients, the public and **BTL-self**, extracts from the test report shall not be reproduced except in full with **BTL's** authorized written approval.

**BTL's** laboratory quality assurance procedures are in compliance with the **ISO Guide 17025** requirements, and accredited by the conformity assessment authorities listed in this test report.

### **Limitation**

For the use of the authority's logo is limited unless the Test Standard(s)/Scope(s)/Item(s) mentioned in this test report is (are) included in the conformity assessment authorities acceptance respective.

## CONTENTS

REPORT ISSUED HISTORY		5
1	CERTIFICATION	6
2	SUMMARY OF TEST RESULTS	7
2.1	TEST FACILITY	8
2.2	MEASUREMENT UNCERTAINTY	8
3	GENERAL INFORMATION	11
3.1	DESCRIPTION OF EUT	11
3.2	TEST MODES	13
3.3	BLOCK DIAGRAM SHOWING THE CONFIGURATION OF SYSTEM TESTED	15
3.4	SUPPORT UNITS	15
4	RF POWER OUTPUT TEST	16
4.1	LIMIT	16
4.2	TEST PROCEDURE	16
4.3	DEVIATION FROM TEST STANDARD	16
4.4	TEST SETUP	16
4.5	TEST RESULT	16
5	PEAK-TO-AVERAGE RATIO (PAR) TEST	17
5.1	LIMIT	17
5.2	TEST PROCEDURE	17
5.3	DEVIATION FROM TEST STANDARD	17
5.4	TEST SETUP	17
5.5	TEST RESULT	17
6	OCCUPIED BANDWIDTH TEST	18
6.1	TEST PROCEDURE	18
6.2	DEVIATION FROM TEST STANDARD	18
6.3	TEST SETUP	18
6.4	TEST RESULT	18
7	OUT OF BAND EMISSIONS TEST	19
7.1	LIMIT	19
7.2	TEST PROCEDURE	19
7.3	DEVIATION FROM TEST STANDARD	19
7.4	TEST SETUP	19
7.5	TEST RESULT	19
8	SPURIOUS EMISSIONS AT ANTENNA TERMINALS TEST	20
8.1	LIMIT	20
8.2	TEST PROCEDURE	20
8.3	DEVIATION FROM TEST STANDARD	20
8.4	TEST SETUP	20
8.5	TEST RESULT	20
9	FIELD STRENGTH OF SPURIOUS RADIATION TEST	21
9.1	LIMIT	21

9.2	TEST PROCEDURE	21
9.3	DEVIATION FROM TEST STANDARD	21
9.4	TEST SETUP	21
9.5	TEST RESULT	22
10	FREQUENCY STABILITY TEST	23
10.1	LIMIT	23
10.2	TEST PROCEDURE	23
10.3	DEVIATION FROM TEST STANDARD	23
10.4	TEST SETUP	23
10.5	TEST RESULT	23
11	LIST OF MEASURING EQUIPMENTS	24
12	EUT TEST PHOTO	25
APPENDIX A	RF POWER OUTPUT	29
APPENDIX B	PEAK-TO-AVERAGE RATIO (PAR)	42
APPENDIX C	OCCUPIED BANDWIDTH	64
APPENDIX D	OUT OF BAND EMISSIONS	88
APPENDIX E	SPURIOUS EMISSIONS AT ANTENNA TERMINALS	120
APPENDIX F	FIELD STRENGTH OF SPURIOUS RADIATION	128
APPENDIX G	FREQUENCY STABILITY	185

**REPORT ISSUED HISTORY**

Issue No.	Description	Issued Date
BTL-FCCP-8-1710083	Original Issue.	Mar. 01, 2018

## 1 CERTIFICATION

Equipment : Computer  
Brand Name : ADVANTECH  
Test Model : AIM-10W  
Series Model : AIM-10WXXXXXXXXXXXXXXXXXX  
(where X may be any alphanumeric character , blank or "-".)  
Applicant : Advantech Co., Ltd.  
Manufacturer : Advantech Co., Ltd.  
Address : No.1, Alley 20, Lane 26, Rueiguang Road, Neihu District, Taipei 11491, Taiwan, R.O.C.  
Date of Test : Nov. 13, 2017 ~ Feb. 27, 2018  
Test Sample : Production Unit  
Standard(s) : 47 CRF FCC Part 2  
47 CRF FCC Part 27, Subpart L  
KDB 971168 D01 Power Meas License Digital Systems v03  
ANSI/TIA-603-D-2010

The above equipment has been tested and found in compliance with the requirement of the relative standards by BTL Inc.

The test data, data evaluation, and equipment configuration contained in our test report (Ref No. BTL-FCCP-8-1710083) were obtained utilizing the test procedures, test instruments, test sites that has been accredited by the Authority of TAF according to the ISO-17025 quality assessment standard and technical standard(s).

**Test result included in this report is only for the WCDMA Band IV, LTE Band 4, 7, 12, 13, 30 and 41 part.**

## 2 SUMMARY OF TEST RESULTS

Test procedures according to the technical standards.

FCC Clause No	Description	Test Result	Judgement	Tested By
§2.1046 §27.50(d)(4)	RF Power Output	APPENDIX A	Pass	Kenji Lin
§27.50	Peak-to-Average Ratio (PAR)	APPENDIX B	Pass	Kenji Lin
§2.1049 §27.53(h)	Occupied Bandwidth	APPENDIX C	Pass	Kenji Lin
§2.1051 §27.53(h)	Out of Band Emissions	APPENDIX D	Pass	Kenji Lin
§2.1051 §27.53(h)	Spurious Emissions at Antenna Terminals	APPENDIX E	Pass	Kenji Lin
§2.1053 §27.53(h)	Field strength of spurious radiation	APPENDIX F	Pass	Kenji Lin
§2.1055 §27.54	Frequency stability	APPENDIX G	Pass	Kenji Lin

**NOTE:**

(1) "N/A" denotes test is not applicable in this Test Report.

## 2.1 TEST FACILITY

The test facilities used to collect the test data in this report:

- CB08:** (FCC RN:674415; FCC DN:TW0659; IC Assigned Code:20088-1)  
No. 68-1, Ln. 169, Sec. 2, Datong Rd., Xizhi Dist., New Taipei City 221, Taiwan (R.O.C.)
- CB11:** (FCC RN:674415; FCC DN:TW0659; IC Assigned Code:20088-2)  
No. 68-1, Ln. 169, Sec. 2, Datong Rd., Xizhi Dist., New Taipei City 221, Taiwan (R.O.C.)
- CB15:** (FCC RN:674415; FCC DN:TW0659; IC Assigned Code:20088-5)  
No. 68-1, Ln. 169, Sec. 2, Datong Rd., Xizhi Dist., New Taipei City 221, Taiwan (R.O.C.)
- CB16:** (FCC RN:674415; FCC DN:TW0659; IC Assigned Code:20088-6)  
No. 68-1, Ln. 169, Sec. 2, Datong Rd., Xizhi Dist., New Taipei City 221, Taiwan (R.O.C.)
- TR03:** (FCC RN:674415; FCC DN:TW0659)  
No. 68-1, Ln. 169, Sec. 2, Datong Rd., Xizhi Dist., New Taipei City 221, Taiwan (R.O.C.)

## 2.2 MEASUREMENT UNCERTAINTY

Where relevant, the following measurement uncertainty levels have been estimated for tests performed on the EUT as specified in CISPR 16-4-2. The BTL measurement uncertainty is less than the CISPR 16-4-2  $U_{CISPR}$  requirement.

The reported uncertainty of measurement  $y \pm U$ , where expanded uncertainty  $U$  is based on a standard uncertainty multiplied by a coverage factor of  $k=2$ , providing a level of confidence of approximately 95 %.

### A. Conducted test:

Applied	Parameter	Uncertainty
<input checked="" type="checkbox"/>	RF Power Output	$\pm 0.24$ dB
<input checked="" type="checkbox"/>	Frequency stability	$\pm 1.2 \times 10^{-7}$
<input checked="" type="checkbox"/>	Occupied Bandwidth	$\pm 3.8$ %
<input checked="" type="checkbox"/>	Spurious Emissions at Antenna Terminals	$\pm 2.71$ dB
<input checked="" type="checkbox"/>	Temperature	$\pm 0.08$ °C



B. Radiated emissions below 1 GHz test:

Applied	Test Site	Method	Measurement Frequency Range	Ant. H / V	U (dB)
<input type="checkbox"/>	CB08 (10m)	CISPR	30 MHz ~ 200 MHz	V	3.48
			30 MHz ~ 200 MHz	H	3.08
			200 MHz ~ 1,000 MHz	V	3.94
			200 MHz ~ 1,000 MHz	H	3.46
<input type="checkbox"/>	CB08 (3m)	CISPR	30 MHz ~ 200 MHz	V	3.68
			30 MHz ~ 200 MHz	H	3.28
			200 MHz ~ 1,000 MHz	V	4.26
			200 MHz ~ 1,000 MHz	H	3.92
<input type="checkbox"/>	CB11 (3m)	CISPR	30 MHz ~ 200 MHz	V	4.26
			30 MHz ~ 200 MHz	H	3.76
			200 MHz ~ 1,000 MHz	V	4.46
			200 MHz ~ 1,000 MHz	H	3.84
<input checked="" type="checkbox"/>	CB15 (3m)	CISPR	30 MHz ~ 200 MHz	V	4.20
			30 MHz ~ 200 MHz	H	3.64
			200 MHz ~ 1,000 MHz	V	4.56
			200 MHz ~ 1,000 MHz	H	3.90
<input type="checkbox"/>	CB16 (3m)	CISPR	30 MHz ~ 200 MHz	V	4.20
			30 MHz ~ 200 MHz	H	3.64
			200 MHz ~ 1,000 MHz	V	4.56
			200 MHz ~ 1,000 MHz	H	3.90

C. Radiated emissions above 1 GHz test:

Applied	Test Site	Method	Measurement Frequency Range	Ant. H / V	U (dB)
<input type="checkbox"/>	CB08 (3m)	CISPR	1 GHz ~ 6 GHz	V	4.40
			1 GHz ~ 6 GHz	H	3.88
			6 GHz ~18 GHz	V	4.70
			6 GHz ~18 GHz	H	4.08
<input type="checkbox"/>	CB11 (3m)	CISPR	1 GHz ~ 6 GHz	V	4.44
			1 GHz ~ 6 GHz	H	4.40
			6 GHz ~18 GHz	V	4.02
			6 GHz ~18 GHz	H	4.00
<input checked="" type="checkbox"/>	CB15 (3m)	CISPR	1 GHz ~ 6 GHz	V	4.46
			1 GHz ~ 6 GHz	H	4.40
			6 GHz ~18 GHz	V	3.88
			6 GHz ~18 GHz	H	4.00
<input type="checkbox"/>	CB16 (3m)	CISPR	1 GHz ~ 6 GHz	V	4.46
			1 GHz ~ 6 GHz	H	4.40
			6 GHz ~18 GHz	V	3.88
			6 GHz ~18 GHz	H	4.00

Applied	Test Site	Method	Measurement Frequency Range	U (dB)
<input type="checkbox"/>	CB08 (1m)	CISPR	18 GHz ~ 26.5 GHz	4.68
			26.5 GHz ~ 40 GHz	5.16
<input type="checkbox"/>	CB11 (1m)	CISPR	18 GHz ~ 26.5 GHz	4.76
			26.5 GHz ~ 40 GHz	5.24
<input checked="" type="checkbox"/>	CB15 (1m)	CISPR	18 GHz ~ 26.5 GHz	4.62
			26.5 GHz ~ 40 GHz	5.12
<input type="checkbox"/>	CB16 (1m)	CISPR	18 GHz ~ 26.5 GHz	4.62
			26.5 GHz ~ 40 GHz	5.12

Note: Unless specifically mentioned, the uncertainty of measurement has not been taken into account to declare the compliance or non-compliance to the specification.

Our calculated Measurement Instrumentation Uncertainty is shown in the tables above. These are our  $U_{lab}$  values in CISPR 16-4-2 terminology.

Since Table 1 of CISPR 16-4-2 has values of measurement instrumentation uncertainty, called  $U_{CISPR}$ , as follows:

Conducted Disturbance (mains port) – 150 kHz – 30 MHz : 3.6 dB

Radiated Disturbance (electric field strength on an open area test site or alternative test site) – 30 MHz – 1000 MHz : 5.2 dB

### 3 GENERAL INFORMATION

#### 3.1 DESCRIPTION OF EUT

Equipment	Computer					
Brand Name	ADVANTECH					
Test Model	AIM-10W					
Series Model	AIM-10WXXXXXXXXXXXXXXXXXX (where X may be any alphanumeric character , blank or “-”.)					
Model Difference	Different model distribute to different area.					
Power Source	DC Voltage supplied from AC/DC adapter.					
Power Rating	I/P: AC 100-240V~, 1.5A, 50~60Hz, 1.5A O/P: DC 19V---3.42A					
Products Covered						
AC Adapter Manufacturer	TAMURA	Model	XEW1934N			
WWAN Module Manufacturer	Sierra Wireless	Model	EM7455 (FCC ID: N7NEM7455)			
Specification information						
Modulation Type	WCDMA	UL: BPSK DL: QPSK				
	LTE	UL: QPSK,16QAM DL: QPSK,16QAM				
Band	Operation Frequency	Modulation Type	Maximum EIRP RF Power Output		Maximum Frequency Tolerance	Emission Designator
	MHz		dBm	W		
WCDMA Band IV	1712.4 to 1752.6	BPSK	20.21	0.105	0.0043	4M16F9W
LTE Band 4	1710.7 to 1754.3	QPSK	20.45	0.111	0.0039	18M1G7D
		16QAM	19.65	0.092		18M1W7D
LTE Band 7	2502.5 to 2567.5	QPSK	14.97	0.031	0.0027	17M9G7D
		16QAM	14.31	0.027		17M9W7D
LTE Band 30	2307.5 to 2312.5	QPSK	16.36	0.043	0.0032	8M99G7D
		16QAM	15.70	0.037		8M98W7D
LTE Band 41	2498.5 to 2687.5	QPSK	15.90	0.039	0.0036	18M5G7D
		16QAM	15.18	0.033		18M5W7D
Band	Operation Frequency	Modulation Type	Maximum ERP RF Power Output		Maximum Frequency Tolerance	Emission Designator
	MHz		dBm	W		
LTE Band 12	699.7 to 715.3	QPSK	16.84	0.048	0.0082	9M02G7D
		16QAM	16.46	0.044		9M02W7D
LTE Band 13	779.5 to 784.5	QPSK	14.71	0.030	0.0073	9M01G7D
		16QAM	14.00	0.025		8M99W7D

**NOTE:**

- (1) For a more detailed features description, please refer to the manufacturer's specifications or the user's manual.

(2) Table for Filed Antenna:

Ant.	Brand	Model	Type	Connector	Frequency Range (MHz)	Gain w/ Cable loss (dBi)	Gain w/o Cable Loss (dBi)	Cable Loss (dBi)
MAIN	INPAQ Corporation	P/N: 6036B0207401 (WA-F-LTE12-02-001)	PIFA	I-PEX MHF4-L	699-715	-3.70	-3.34	0.36
					704-716	-3.67	-3.21	0.36
					824-849	-5.77	-5.39	0.38
					777-787	-5.44	-5.07	0.37
					832-862	-7.24	-6.86	0.38
					880-915	-11.97	-11.38	0.59
					1710-1755	-2.29	-1.7	0.59
					1710-1785	-2.45	-1.86	0.59
					1710-1780	-2.15	-1.56	0.59
					1850-1910	-7.51	-6.91	0.6
					1920-1980	-5.71	-5.10	0.61
					2305-2315	-5.27	-4.58	0.69
					2500-2570	-6.37	-5.66	0.71
					2496-2690	-5.57	-4.86	0.71
AUX	INPAQ Corporation	P/N: 6036B0207201 (WA-F-LTE12LB G1-12-001)	PIFA	I-PEX MHF4-L	2620-2690	-5.38	-4.67	0.71
					717-728	-11.63	-11.53	0.10
					729-745	-11.03	-10.93	0.10
					734-746	-10.89	-10.79	0.10
					746-756	-10.46	-10.35	0.11
					869-894	-11.61	-11.5	0.11
					791-821	-4.85	-4.74	0.11
					925-960	-6.54	-6.42	0.12
					1805-1880	-2.91	-2.75	0.16
					1930-1990	-2.71	-2.54	0.17
					2110-2155	-1.72	-1.55	0.17
					2110-2200	-1.73	-1.55	0.18
					2350-2360	-2.88	-2.7	0.18
					2496-2690	0.19	0.38	0.19
2620-2690	0.19	0.38	0.19					

### 3.2 TEST MODES

To investigate the maximum EMI emission characteristics generated from EUT, the test system was pre-scanning tested based on the consideration of following EUT operation mode or test configuration mode which possibly have effect on EMI emission level. Each of these EUT operation mode(s) or test configuration mode(s) mentioned above was evaluated respectively.

The EUT system operated these modes were found to be the worst case during the pre-scanning test as following:

WCDMA				
Test Items	Band	Test Channel		
		L	M	H
RF Power Output	IV	V	V	V
Peak-to-Average Ratio (PAR)	IV	V	V	V
Occupied Bandwidth	IV	V	V	V
Out of Band Emissions	IV	V		V
Spurious Emissions at Antenna Terminals	IV		V	
Field strength of spurious radiation	IV		V	
Frequency stability	IV		V	

LTE															
Test Items	Band	Bandwidth (MHz)						Modulation		RB Size			Test Channel		
		1.4	3	5	10	15	20	QPSK	16QAM	1	Half	Full	L	M	H
RF Power Output	4	V	V	V	V	V	V	V	V	V	V	V	V	V	V
	7	-	-	V	V	V	V	V	V	V	V	V	V	V	V
	12	V	V	V	V	-	-	V	V	V	V	V	V	V	V
	13	-	-	V	V	-	-	V	V	V	V	V	V	V	V
	30	-	-	V	V	-	-	V	V	V	V	V	V	V	V
	41	-	-	V	V	V	V	V	V	V	V	V	V	V	V
Peak-to-Average Ratio (PAR)	4	V	V	V	V	V	V	V	V	V			V	V	V
	7	-	-	V	V	V	V	V	V	V			V	V	V
	12	V	V	V	V	-	-	V	V	V			V	V	V
	13	-	-	V	V	-	-	V	V	V			V	V	V
	30	-	-	V	V	-	-	V	V	V			V	V	V
	41	-	-	V	V	V	V	V	V	V			V	V	V
Occupied Bandwidth	4	V	V	V	V	V	V	V	V			V	V	V	V
	7	-	-	V	V	V	V	V	V			V	V	V	V
	12	V	V	V	V	-	-	V	V			V	V	V	V
	13	-	-	V	V	-	-	V	V			V	V	V	V
	30	-	-	V	V	-	-	V	V			V	V	V	V
	41	-	-	V	V	V	V	V	V			V	V	V	V

LTE															
Test Items	Band	Bandwidth (MHz)						Modulation		RB Size			Test Channel		
		1.4	3	5	10	15	20	QPSK	16QAM	1	Half	Full	L	M	H
Out of Band Emissions	4	V	V	V	V	V	V	V	V	V		V	V		V
	7	-	-	V	V	V	V	V	V	V		V	V		V
	12	V	V	V	V	-	-	V	V	V		V	V		V
	13	-	-	V	V	-	-	V	V	V		V	V		V
	30	-	-	V	V	-	-	V	V	V		V	V		V
	41	-	-	V	V	V	V	V	V	V		V	V		V
Spurious Emissions at Antenna Terminals	4	V	V	V	V	V	V	V	V	V				V	
	7	-	-	V	V	V	V	V	V	V				V	
	12	V	V	V	V	-	-	V	V	V				V	
	13	-	-	V	V	-	-	V	V	V				V	
	30	-	-	V	V	-	-	V	V	V				V	
	41	-	-	V	V	V	V	V	V	V				V	
Field strength of spurious radiation	4						V	V		V				V	
	7	-	-				V	V		V				V	
	12				V	-	-	V		V				V	
	13	-	-		V	-	-	V		V				V	
	30	-	-		V	-	-	V		V				V	
	41	-	-				V	V		V				V	
Frequency stability	4	V	V	V	V	V	V	V		V				V	
	7	-	-	V	V	V	V	V		V				V	
	12	V	V	V	V	-	-	V		V				V	
	13	-	-	V	V	-	-	V		V				V	
	30	-	-	V	V	-	-	V		V				V	
	41	-	-	V	V	V	V	V		V				V	

**NOTE:**

- (1) The marker "V" means this configuration is used for testing.
- (2) The gray marker "-" means this bandwidth is not supported.

**EUT TEST CONDITIONS:**

Test Item	Environmental Conditions	Test Voltage
RF Power Output	25 °C, 60 % RH	AC 120V/60Hz
Peak-to-Average Ratio (PAR)	25 °C, 60 % RH	AC 120V/60Hz
Occupied Bandwidth	25 °C, 60 % RH	AC 120V/60Hz
Out of Band Emissions	25 °C, 60 % RH	AC 120V/60Hz
Spurious Emissions at Antenna Terminals	25 °C, 60 % RH	AC 120V/60Hz
Field strength of spurious radiation	23 °C, 70 % RH	AC 120V/60Hz
Frequency stability	Normal and Extreme	Normal and Extreme

**3.3 BLOCK DIAGRAM SHOWING THE CONFIGURATION OF SYSTEM TESTED**

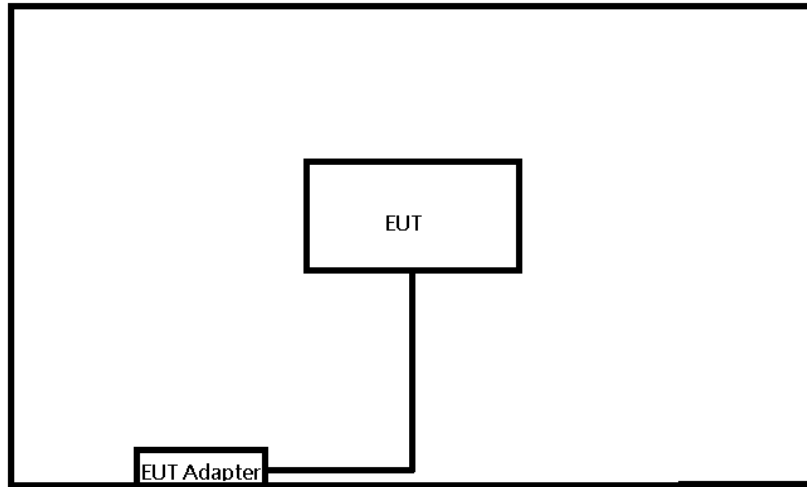

**3.4 SUPPORT UNITS**

The EUT has been tested as an independent unit together with other necessary accessories or support units. The following support units or accessories were used to form a representative test configuration during the tests.

Item	Equipment	Brand	Model/Type No.	FCC ID	Series No.
-	-	-	-	-	-

Item	Shielded Type	Ferrite Core	Length	Note
-	-	-	-	-

## 4 RF POWER OUTPUT TEST

### 4.1 LIMIT

Band	Limit
WCDMA Band IV	Fixed, mobile, and portable (hand-held) stations are limited to 1 watt EIRP.
LTE Band 4	Fixed, mobile, and portable (hand-held) stations are limited to 1 watt EIRP.
LTE Band 7, 41	Mobile and other user stations. Mobile stations are limited to 2.0 watts EIRP. All user stations are limited to 2.0 watts transmitter output power.
LTE Band 12	Portable stations (hand-held devices) and fixed and mobile stations are limited to 3 watts ERP.
LTE Band 13	Portable stations (hand-held devices) are limited to 3 watts ERP.
LTE Band 30	Mobile and portable stations. (i) For mobile and portable stations transmitting in the 2305-2315 MHz band or the 2350-2360 MHz band, the average EIRP must not exceed 50 milliwatts within any 1 megahertz of authorized bandwidth, except that for mobile and portable stations compliant with 3GPP LTE standards or another advanced mobile broadband protocol that avoids concentrating energy at the edge of the operating band the average EIRP must not exceed 250 milliwatts within any 5 megahertz of authorized bandwidth but may exceed 50 milliwatts within any 1 megahertz of authorized bandwidth.

### 4.2 TEST PROCEDURE

#### EIRP / ERP Power Measurement:

EIRP = Conducted Power + Antenna gain.

ERP power = EIPR power - 2.15 dBi.

#### Conducted Power Measurement:

The EUT was set up for the maximum power with WCDMA and LTE link data modulation and link up with simulator. Set the EUT to transmit under low, middle and high channel and record the power level shown on simulator.

### 4.3 DEVIATION FROM TEST STANDARD

No deviation.

### 4.4 TEST SETUP

#### Conducted Power Measurement:

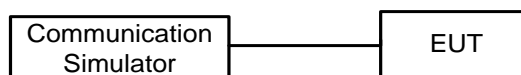

### 4.5 TEST RESULT

Please refer to the APPENDIX A.



**5 PEAK-TO-AVERAGE RATIO (PAR) TEST**

**5.1 LIMIT**

In measuring transmissions in this band using an average power technique, the peak-to-average ratio (PAR) of the transmission may not exceed 13 dB.

**5.2 TEST PROCEDURE**

- a. Set resolution/measurement bandwidth  $\geq$  signal's occupied bandwidth.
- b. Set the number of counts to a value that stabilizes the measured CCDF curve.
- c. Record the maximum PAPR level associated with a probability of 0.1%.

**5.3 DEVIATION FROM TEST STANDARD**

No deviation.

**5.4 TEST SETUP**

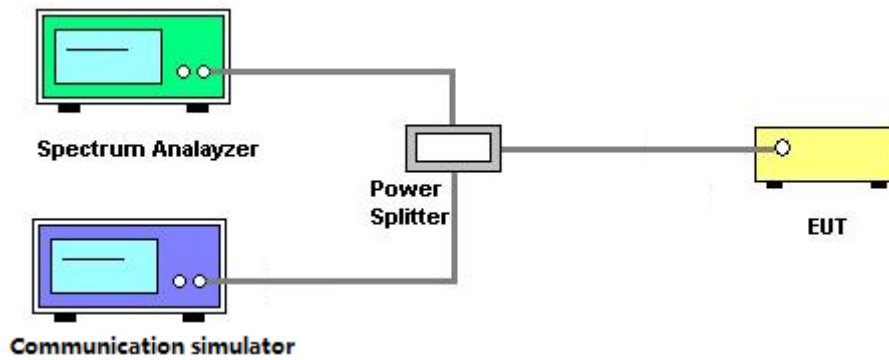

**5.5 TEST RESULT**

Please refer to the APPENDIX B.

**6 OCCUPIED BANDWIDTH TEST**

**6.1 TEST PROCEDURE**

The EUT makes a call to the communication simulator. All measurements were done at low, middle and high operational frequency range. The communication simulator station system controlled a EUT to export maximum output power under transmission mode and specific channel frequency. Use OBW measurement function of Spectrum analyzer to measure 99 % occupied bandwidth and 26 dB bandwidth.

**6.2 DEVIATION FROM TEST STANDARD**

No deviation.

**6.3 TEST SETUP**

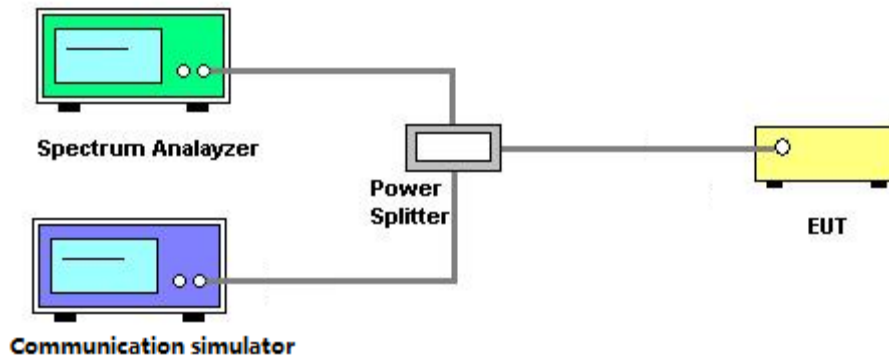

**6.4 TEST RESULT**

Please refer to the APPENDIX C.

## 7 OUT OF BAND EMISSIONS TEST

### 7.1 LIMIT

The power of any emission outside of the authorized operating frequency ranges must be attenuated below the transmitting power (P) by a factor of at least  $43 + 10 \log(P)$  dB.

In the 1 MHz bands immediately outside and adjacent to the frequency block a resolution bandwidth of at least one percent of the emission bandwidth of the fundamental emission of the transmitter may be employed.

### 7.2 TEST PROCEDURE

- All measurements were done at low and high operational frequency range.
- The center frequency of spectrum is the band edge frequency and span is 5 MHz. RB of the spectrum is 100 kHz and VB of the spectrum is 300 kHz (WCDMA).
- The center frequency of spectrum is the band edge frequency and span is 1 MHz. RB of the spectrum is 13 kHz and VB of the spectrum is 51 kHz (LTE Bandwidth 1.4MHz).
- The center frequency of spectrum is the band edge frequency and span is 1 MHz. RB of the spectrum is 30 kHz and VB of the spectrum is 100 kHz (LTE Bandwidth 3MHz).
- The center frequency of spectrum is the band edge frequency and span is 1 MHz. RB of the spectrum is 100 kHz and VB of the spectrum is 300 kHz (LTE Bandwidth 5MHz/10MHz).
- The center frequency of spectrum is the band edge frequency and span is 1MHz. RB of the spectrum is 150 kHz and VB of the spectrum is 470 kHz (LTE Bandwidth 15MHz).
- The center frequency of spectrum is the band edge frequency and span is 1MHz. RB of the spectrum is 180 kHz and VB of the spectrum is 560 kHz (LTE Bandwidth 20MHz).
- Record the max trace plot into the test report.

### 7.3 DEVIATION FROM TEST STANDARD

No deviation.

### 7.4 TEST SETUP

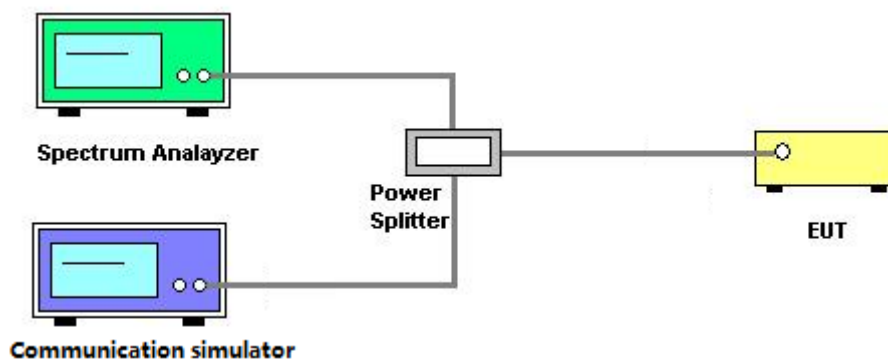

### 7.5 TEST RESULT

Please refer to the APPENDIX D.

## 8 SPURIOUS EMISSIONS AT ANTENNA TERMINALS TEST

### 8.1 LIMIT

The power of any emission outside of the authorized operating frequency ranges must be attenuated below the transmitting power (P) by a factor of at least  $43 + 10 \log(P)$  dB. The emission limit is equal to -13 dBm.

### 8.2 TEST PROCEDURE

- a. The testing follows FCC KDB 971168 D01 Power Meas License Digital Systems v03.
- b. The EUT was connected to spectrum analyzer and system simulator via a power divider.
- c. The band edges of low and high channels for the highest RF powers were measured. Set RBW  $\geq 1\%$  EBW in the 1 MHz band immediately outside and adjacent to the band edge.
- d. Set spectrum analyzer with RMS detector.
- e. The RF fundamental frequency should be excluded against the limit line in the operating frequency band.
- f. The limit line is derived from  $43 + 10\log(P)$  dB below the transmitter power P (Watts)
  - =  $P(W) - [43 + 10 \log(P)]$  (dB)
  - =  $[30 + 10 \log(P)]$  (dBm) -  $[43 + 10 \log(P)]$  (dB)
  - = - 13 dBm

### 8.3 DEVIATION FROM TEST STANDARD

No deviation.

### 8.4 TEST SETUP

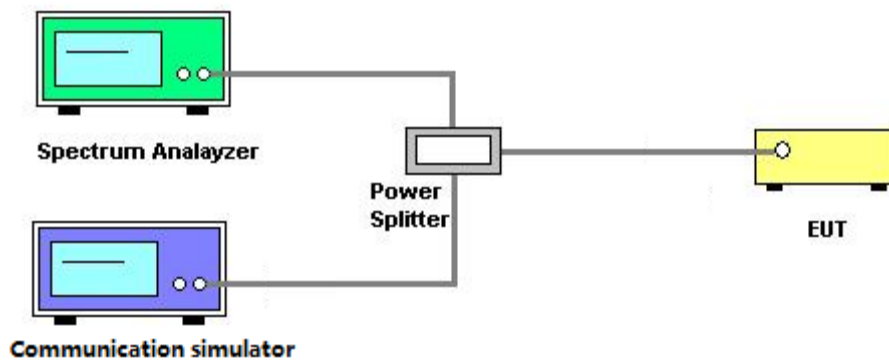

### 8.5 TEST RESULT

Please refer to the APPENDIX E.

## 9 FIELD STRENGTH OF SPURIOUS RADIATION TEST

### 9.1 LIMIT

The power of any emission outside of the authorized operating frequency ranges must be attenuated below the transmitting power (P) by a factor of at least  $43 + 10 \log(P)$  dB. The emission limit is equal to -13 dBm.

### 9.2 TEST PROCEDURE

- In the semi-anechoic chamber, EUT placed on the 0.8 m height of Turn Table, rotated the table around 360 degrees to search the maximum radiation power and receiver antenna shall be rotated vertical and horizontal polarization and moved height from 1 m to 4 m to find the maximum polar radiated power. The "Read Value" is the spectrum reading the maximum power value.
- The substitution horn antenna is substituted for EUT at the same position and signals generator export the CW signal to the substitution antenna via a TX cable. Rotated the Turn Table and moved receiving antenna to find the maximum radiation power. Adjust output power level of S.G to get a Value of spectrum reading equal to "Read Value" of step a. Record the power level of S.G.
- $EIRP = \text{Output power level of S.G} - \text{TX cable loss} + \text{Antenna gain of substitution horn.}$
- ERP power can be calculated form EIRP power by subtracting the gain of dipole,  $ERP \text{ power} = EIRP \text{ power} - 2.15 \text{ dBi.}$
- The resolution bandwidth and video bandwidth of test receiver/spectrum analyzer is 1 MHz / 3 MHz.

### 9.3 DEVIATION FROM TEST STANDARD

No deviation.

### 9.4 TEST SETUP

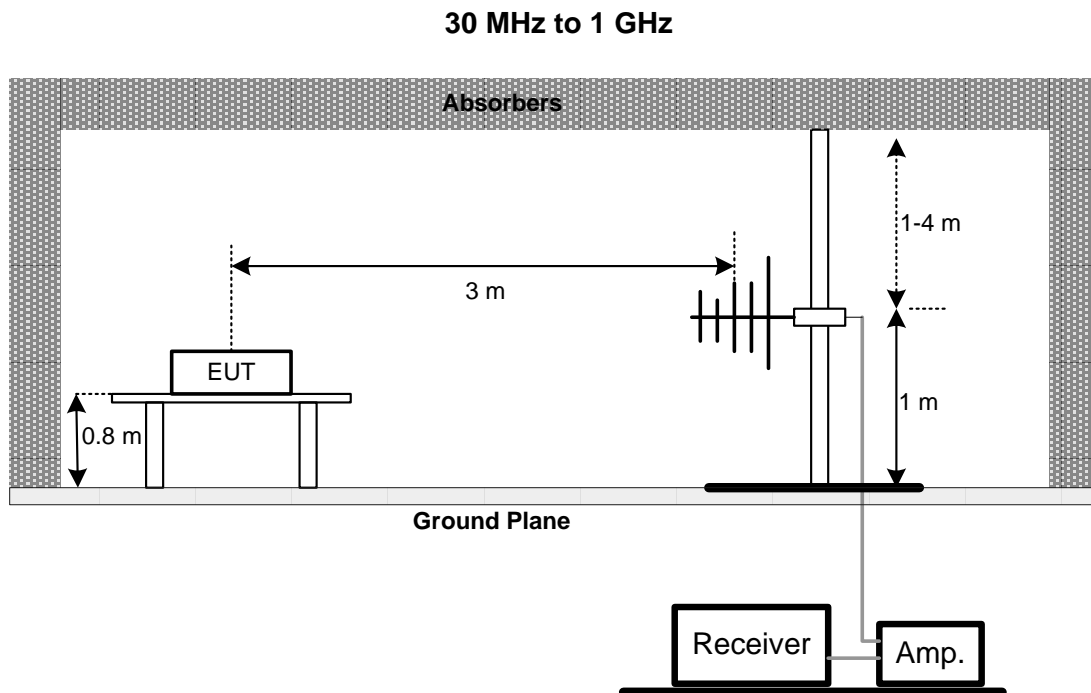

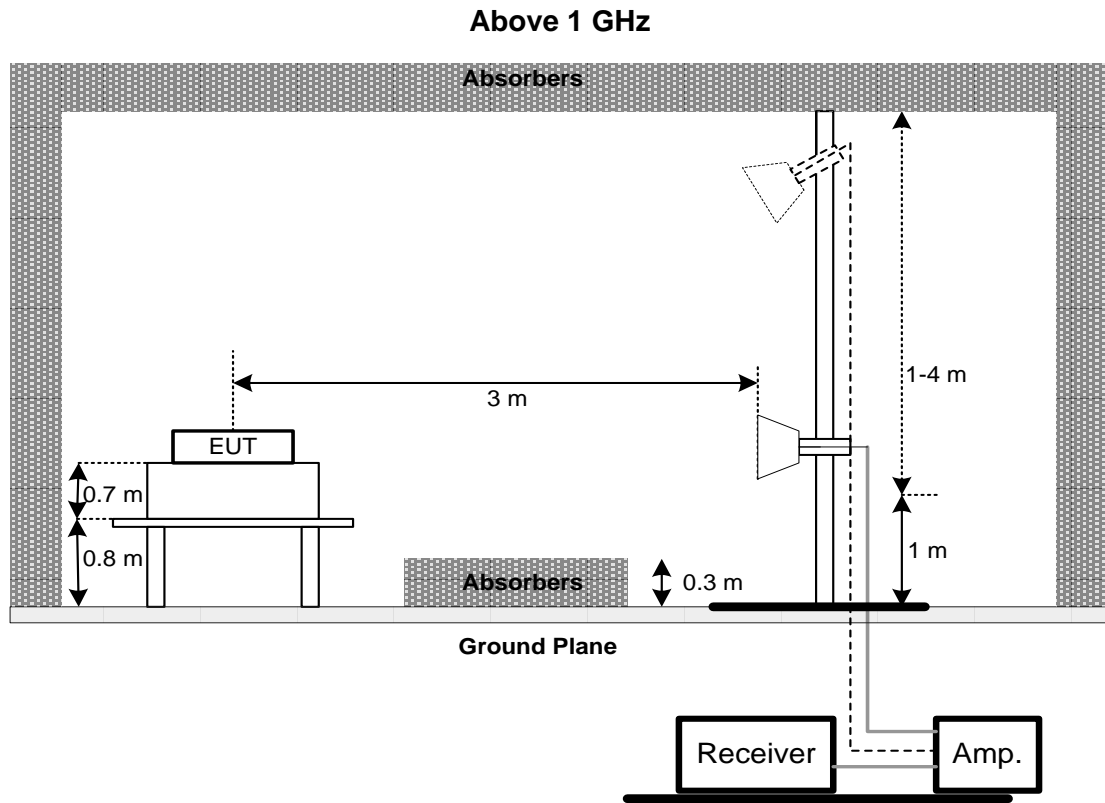

**9.5 TEST RESULT**

Please refer to the APPENDIX F.

## 10 FREQUENCY STABILITY TEST

### 10.1 LIMIT

The frequency stability shall be sufficient to ensure that the fundamental emission stays within the authorized frequency block.

### 10.2 TEST PROCEDURE

- a. Device is placed at the oven room. The oven room could control the temperatures and humidity. Power warm up is at least 15 min and power applied should perform before recording frequency error.
- b. EUT is connected the external power supply to control the DC input power. The test voltage range is from minimum to maximum working voltage. Each step shall be record the frequency error rate.
- c. The temperature range step is 10 degrees in this test items. All temperature levels shall be hold the  $\pm 0.5^{\circ}\text{C}$  during the measurement testing. The each temperature step shall be at least 0.5 hours, consider the EUT could be test under the stability condition.
- d. The frequency error was recorded frequency error from the communication simulator.

### 10.3 DEVIATION FROM TEST STANDARD

No deviation.

### 10.4 TEST SETUP

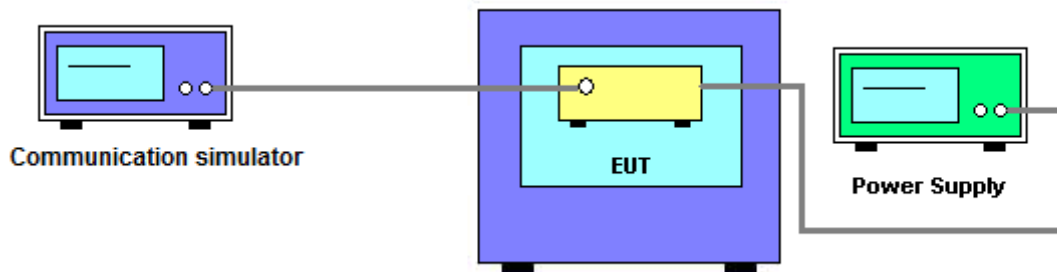

### 10.5 TEST RESULT

Please refer to the APPENDIX G.

## 11 LIST OF MEASURING EQUIPMENTS

RF Power Output and Frequency stability					
Item	Kind of Equipment	Manufacturer	Type No.	Serial No.	Calibrated until
1	Wireless Communications Test Set (WCDMA)	Agilent	8960	US38080149	Oct. 16, 2018
2	Radio Communication Analyzer (LTE)	Anritsu	MT8820C	6201525878	Nov. 04, 2018

Peak-to-Average Ratio (PAR), Occupied Bandwidth, Out of Band Emissions and Spurious Emissions at Antenna Terminals					
Item	Kind of Equipment	Manufacturer	Type No.	Serial No.	Calibrated until
1	EXA Signal Analyzer	Agilent	N9010A	MY54200240	Oct. 01, 2018
2	Wireless Communications Test Set (WCDMA)	Agilent	8960	US38080149	Oct. 16, 2018
3	Radio Communication Analyzer (LTE)	Anritsu	MT8820C	6201525878	Nov. 04, 2018

Field strength of spurious radiation					
Item	Kind of Equipment	Manufacturer	Type No.	Serial No.	Calibrated until
1	Preamplifier	EMCI	012645B	980267	Feb. 27, 2019
2	Preamplifier	EMCI	EMC02325	980217	Dec. 27, 2019
3	Test Cable	EMCI	EMC104-SM-SM-8000	8m	Jan. 03, 2019
4	Test Cable	EMCI	EMC104-SM-SM-800	150207	Jan. 03, 2019
5	Test Cable	EMCI	EEMC104-SM-SM-3000	151205	Jan. 03, 2019
6	MXE EMI Receiver	Agilent	N9038A	MY55420127	Jan. 08, 2019
7	Signal Analyzer	Agilent	N9010A	MY52220990	Feb. 21, 2019
8	Loop Ant	EMCO	6502	42960	Nov. 23, 2018
9	Horn Ant	SCHWARZBECK	BBHA 9120D	9120D-1342	Feb. 27, 2019
10	Trilog-Broadband Antenna	Schwarzbeck	VULB 9168	9168-548	Jan. 15, 2019
11	5dB Attenuator	EMCI	EMCI-N-6-05	AT-N0623	Jan. 15, 2019
12	Wireless Communications Test Set (WCDMA)	Agilent	8960	US38080149	Oct. 16, 2018
13	Radio Communication Analyzer (LTE)	Anritsu	MT8820C	6201525878	Nov. 04, 2018

Remark: "N/A" denotes no model name, no serial no. or no calibration specified.  
All calibration period of equipment list is one year.



## APPENDIX A RF POWER OUTPUT

CONTINUE ON NEXT PAGE

Band		WCDMA Band IV					
Antenna Gain (dBi)	-2.29	Conducted Power (dBm)			EIRP Power (dBm)		
Tx Channel		1312	1413	1513	1312	1413	1513
Rx Channel		1537	1638	1738	1537	1638	1738
Frequency (MHz)		1712.4	1732.6	1752.6	1712.4	1732.6	1752.6
RMC 12.2K		22.48	22.42	22.50	20.19	20.13	<b>20.21</b>
HSDPA Subtest-1		21.27	21.26	21.31	18.98	18.97	19.02
HSDPA Subtest-2		21.31	21.28	21.35	19.02	18.99	19.06
HSDPA Subtest-3		20.82	20.80	20.77	18.53	18.51	18.48
HSDPA Subtest-4		20.81	20.74	20.76	18.52	18.45	18.47
HSUPA Subtest-1		21.22	21.14	21.27	18.93	18.85	18.98
HSUPA Subtest-2		20.23	20.15	20.28	17.94	17.86	17.99
HSUPA Subtest-3		20.45	20.37	20.50	18.16	18.08	18.21
HSUPA Subtest-4		20.52	20.44	20.57	18.23	18.15	18.28
HSUPA Subtest-5		21.53	21.45	21.58	19.24	19.16	19.29

Remark: EIRP power = Conducted Power + Antenna gain.

Band				LTE Band 4					
Antenna Gain (dBi)	-2.29			Conducted Power (dBm)			EIRP Power (dBm)		
Channel Bandwidth (MHz)	Modulation	RB Size	RB Offset	Low CH	Mid CH	High CH	Low CH	Mid CH	High CH
				19957	20175	20393	19957	20175	20393
				1710.7 MHz	1732.5 MHz	1754.3 MHz	1710.7 MHz	1732.5 MHz	1754.3 MHz
1.4	QPSK	1	0	22.70	22.60	22.61	<b>20.41</b>	20.31	20.32
		1	2	22.67	22.57	22.58	20.38	20.28	20.29
		1	5	22.61	22.51	22.52	20.32	20.22	20.23
		3	0	22.61	22.51	22.52	20.32	20.22	20.23
		3	1	22.58	22.48	22.49	20.29	20.19	20.20
		3	3	22.53	22.43	22.44	20.24	20.14	20.15
	16QAM	1	0	21.91	21.81	21.82	<b>19.62</b>	19.52	19.53
		1	2	21.89	21.79	21.80	19.60	19.50	19.51
		1	5	21.87	21.77	21.78	19.58	19.48	19.49
		3	0	21.69	21.59	21.60	19.40	19.30	19.31
		3	1	21.62	21.52	21.53	19.33	19.23	19.24
		3	3	21.55	21.45	21.46	19.26	19.16	19.17
		6	0	20.50	20.40	20.41	18.21	18.11	18.12

Band				LTE Band 4					
Antenna Gain (dBi)	-2.29			Conducted Power (dBm)			EIRP Power (dBm)		
Channel Bandwidth (MHz)	Modulation	RB Size	RB Offset	Low CH	Mid CH	High CH	Low CH	Mid CH	High CH
				19965	20175	20385	19965	20175	20385
				1711.5 MHz	1732.5 MHz	1753.5 MHz	1711.5 MHz	1732.5 MHz	1753.5 MHz
3	QPSK	1	0	22.62	22.50	22.39	<b>20.33</b>	20.21	20.10
		1	7	22.58	22.46	22.35	20.29	20.17	20.06
		1	14	22.50	22.38	22.27	20.21	20.09	19.98
		8	0	21.64	21.52	21.41	19.35	19.23	19.12
		8	3	21.62	21.50	21.39	19.33	19.21	19.10
		8	7	21.51	21.39	21.28	19.22	19.10	18.99
		15	0	21.48	21.36	21.25	19.19	19.07	18.96
	16QAM	1	0	21.82	21.70	21.59	<b>19.53</b>	19.41	19.30
		1	7	21.77	21.65	21.54	19.48	19.36	19.25
		1	14	21.40	21.28	21.17	19.11	18.99	18.88
		8	0	20.52	20.40	20.29	18.23	18.11	18.00
		8	3	20.48	20.36	20.25	18.19	18.07	17.96
		8	7	20.37	20.25	20.14	18.08	17.96	17.85
		15	0	20.48	20.36	20.25	18.19	18.07	17.96

Remark: EIRP power = Conducted Power + Antenna gain.

Band				LTE Band 4					
Antenna Gain (dBi)	-2.29			Conducted Power (dBm)			EIRP Power (dBm)		
Channel Bandwidth (MHz)	Modulation	RB Size	RB Offset	Low CH	Mid CH	High CH	Low CH	Mid CH	High CH
				19975	20175	20375	19975	20175	20375
				1712.5 MHz	1732.5 MHz	1752.5 MHz	1712.5 MHz	1732.5 MHz	1752.5 MHz
5	QPSK	1	0	22.65	22.53	22.54	<b>20.36</b>	20.24	20.25
		1	12	22.61	22.49	22.50	20.32	20.20	20.21
		1	24	22.53	22.41	22.42	20.24	20.12	20.13
		12	0	21.67	21.55	21.56	19.38	19.26	19.27
		12	6	21.65	21.53	21.54	19.36	19.24	19.25
		12	13	21.54	21.42	21.43	19.25	19.13	19.14
	16QAM	25	0	21.51	21.39	21.40	19.22	19.10	19.11
		1	0	21.85	21.73	21.74	<b>19.56</b>	19.44	19.45
		1	12	21.80	21.68	21.69	19.51	19.39	19.40
		1	24	21.43	21.31	21.32	19.14	19.02	19.03
		12	0	20.55	20.43	20.44	18.26	18.14	18.15
		12	6	20.51	20.39	20.40	18.22	18.10	18.11
		12	13	20.40	20.28	20.29	18.11	17.99	18.00
		25	0	20.51	20.39	20.40	18.22	18.10	18.11

Band				LTE Band 4					
Antenna Gain (dBi)	-2.29			Conducted Power (dBm)			EIRP Power (dBm)		
Channel Bandwidth (MHz)	Modulation	RB Size	RB Offset	Low CH	Mid CH	High CH	Low CH	Mid CH	High CH
				20000	20175	20350	20000	20175	20350
				1715 MHz	1732.5 MHz	1750 MHz	1715 MHz	1732.5 MHz	1750 MHz
10	QPSK	1	0	22.67	22.60	22.57	<b>20.38</b>	20.31	20.28
		1	24	22.63	22.56	22.53	20.34	20.27	20.24
		1	49	22.55	22.48	22.45	20.26	20.19	20.16
		25	0	21.69	21.62	21.59	19.40	19.33	19.30
		25	12	21.67	21.60	21.57	19.38	19.31	19.28
		25	25	21.56	21.49	21.46	19.27	19.20	19.17
		50	0	21.53	21.46	21.43	19.24	19.17	19.14
	16QAM	1	0	21.87	21.80	21.77	<b>19.58</b>	19.51	19.48
		1	24	21.82	21.75	21.72	19.53	19.46	19.43
		1	49	21.45	21.38	21.35	19.16	19.09	19.06
		25	0	20.57	20.50	20.47	18.28	18.21	18.18
		25	12	20.53	20.46	20.43	18.24	18.17	18.14
		25	25	20.42	20.35	20.32	18.13	18.06	18.03
		50	0	20.53	20.46	20.43	18.24	18.17	18.14

Remark: EIRP power = Conducted Power + Antenna gain.

Band				LTE Band 4					
Antenna Gain (dBi)	-2.29			Conducted Power (dBm)			EIRP Power (dBm)		
Channel Bandwidth (MHz)	Modulation	RB Size	RB Offset	Low CH	Mid CH	High CH	Low CH	Mid CH	High CH
				20025	20175	20325	20025	20175	20325
				1717.5 MHz	1732.5 MHz	1747.5 MHz	1717.5 MHz	1732.5 MHz	1747.5 MHz
15	QPSK	1	0	22.70	22.62	22.60	<b>20.41</b>	20.33	20.31
		1	37	22.66	22.58	22.56	20.37	20.29	20.27
		1	74	22.58	22.50	22.48	20.29	20.21	20.19
		36	0	21.72	21.64	21.62	19.43	19.35	19.33
		36	19	21.70	21.62	21.60	19.41	19.33	19.31
		36	39	21.59	21.51	21.49	19.30	19.22	19.20
		75	0	21.56	21.48	21.46	19.27	19.19	19.17
	16QAM	1	0	21.90	21.82	21.80	<b>19.61</b>	19.53	19.51
		1	37	21.85	21.77	21.75	19.56	19.48	19.46
		1	74	21.48	21.40	21.38	19.19	19.11	19.09
		36	0	20.60	20.52	20.50	18.31	18.23	18.21
		36	19	20.56	20.48	20.46	18.27	18.19	18.17
		36	39	20.45	20.37	20.35	18.16	18.08	18.06
		75	0	20.56	20.48	20.46	18.27	18.19	18.17

Band				LTE Band 4					
Antenna Gain (dBi)	-2.29			Conducted Power (dBm)			EIRP Power (dBm)		
Channel Bandwidth (MHz)	Modulation	RB Size	RB Offset	Low CH	Mid CH	High CH	Low CH	Mid CH	High CH
				20050	20175	20300	20050	20175	20300
				1720 MHz	1732.5 MHz	1745 MHz	1720 MHz	1732.5 MHz	1745 MHz
20	QPSK	1	0	22.74	22.65	22.62	<b>20.45</b>	20.36	20.33
		1	50	22.70	22.61	22.58	20.41	20.32	20.29
		1	99	22.62	22.53	22.50	20.33	20.24	20.21
		50	0	21.76	21.67	21.64	19.47	19.38	19.35
		50	25	21.74	21.65	21.62	19.45	19.36	19.33
		50	50	21.63	21.54	21.51	19.34	19.25	19.22
		100	0	21.60	21.51	21.48	19.31	19.22	19.19
	16QAM	1	0	21.94	21.85	21.82	<b>19.65</b>	19.56	19.53
		1	50	21.89	21.80	21.77	19.60	19.51	19.48
		1	99	21.52	21.43	21.40	19.23	19.14	19.11
		50	0	20.64	20.55	20.52	18.35	18.26	18.23
		50	25	20.60	20.51	20.48	18.31	18.22	18.19
		50	50	20.49	20.40	20.37	18.20	18.11	18.08
		100	0	20.60	20.51	20.48	18.31	18.22	18.19

Remark: EIRP power = Conducted Power + Antenna gain.

Band				LTE Band 7					
Antenna Gain (dBi)	-6.37			Conducted Power (dBm)			EIRP Power (dBm)		
Channel Bandwidth (MHz)	Modulation	RB Size	RB Offset	Low CH	Mid CH	High CH	Low CH	Mid CH	High CH
				20775	21100	21425	20775	21100	21425
				2502.5 MHz	2535 MHz	2567.5 MHz	2502.5 MHz	2535 MHz	2567.5 MHz
5	QPSK	1	0	20.70	20.76	20.64	14.33	14.39	14.27
		1	12	20.81	20.97	20.66	14.44	<b>14.60</b>	14.29
		1	24	20.79	20.64	20.62	14.42	14.27	14.25
		12	0	19.90	19.92	19.70	13.53	13.55	13.33
		12	6	19.84	19.99	19.75	13.47	13.62	13.38
		12	13	19.87	19.86	19.76	13.50	13.49	13.39
	16QAM	25	0	19.91	19.95	19.77	13.54	13.58	13.40
		1	0	20.09	20.14	19.99	13.72	13.77	13.62
		1	12	20.12	20.31	19.97	13.75	<b>13.94</b>	13.60
		1	24	20.13	19.99	19.96	13.76	13.62	13.59
		12	0	18.91	19.02	18.75	12.54	12.65	12.38
		12	6	18.92	19.09	18.84	12.55	12.72	12.47
		12	13	18.82	18.88	18.74	12.45	12.51	12.37
		25	0	18.93	18.88	18.85	12.56	12.51	12.48

Band				LTE Band 7					
Antenna Gain (dBi)	-6.37			Conducted Power (dBm)			EIRP Power (dBm)		
Channel Bandwidth (MHz)	Modulation	RB Size	RB Offset	Low CH	Mid CH	High CH	Low CH	Mid CH	High CH
				20800	21100	21400	20800	21100	21400
				2505 MHz	2535 MHz	2565 MHz	2505 MHz	2535 MHz	2565 MHz
10	QPSK	1	0	20.84	20.90	20.78	14.47	14.53	14.41
		1	24	20.95	21.11	20.80	14.58	<b>14.74</b>	14.43
		1	49	20.93	20.78	20.76	14.56	14.41	14.39
		25	0	20.04	20.06	19.84	13.67	13.69	13.47
		25	12	19.98	20.13	19.89	13.61	13.76	13.52
		25	25	20.01	20.00	19.90	13.64	13.63	13.53
	16QAM	50	0	20.05	20.09	19.91	13.68	13.72	13.54
		1	0	20.23	20.28	20.13	13.86	13.91	13.76
		1	24	20.26	20.45	20.11	13.89	<b>14.08</b>	13.74
		1	49	20.27	20.13	20.10	13.90	13.76	13.73
		25	0	19.05	19.16	18.89	12.68	12.79	12.52
		25	12	19.06	19.23	18.98	12.69	12.86	12.61
		25	25	18.96	19.02	18.88	12.59	12.65	12.51
		50	0	19.07	19.02	18.99	12.70	12.65	12.62

Remark: EIRP power = Conducted Power + Antenna gain.

Band				LTE Band 7					
Antenna Gain (dBi)	-6.37			Conducted Power (dBm)			EIRP Power (dBm)		
Channel Bandwidth (MHz)	Modulation	RB Size	RB Offset	Low CH	Mid CH	High CH	Low CH	Mid CH	High CH
				20825	21100	21375	20825	21100	21375
				2507.5 MHz	2535 MHz	2562.5 MHz	2507.5 MHz	2535 MHz	2562.5 MHz
15	QPSK	1	0	20.96	21.02	20.90	14.59	14.65	14.53
		1	37	21.07	21.23	20.92	14.70	<b>14.86</b>	14.55
		1	74	21.05	20.90	20.88	14.68	14.53	14.51
		36	0	20.16	20.18	19.96	13.79	13.81	13.59
		36	19	20.10	20.25	20.01	13.73	13.88	13.64
		36	39	20.13	20.12	20.02	13.76	13.75	13.65
		75	0	20.17	20.21	20.03	13.80	13.84	13.66
	16QAM	1	0	20.35	20.40	20.25	13.98	14.03	13.88
		1	37	20.38	20.57	20.23	14.01	<b>14.20</b>	13.86
		1	74	20.39	20.25	20.22	14.02	13.88	13.85
		36	0	19.17	19.28	19.01	12.80	12.91	12.64
		36	19	19.18	19.35	19.10	12.81	12.98	12.73
		36	39	19.08	19.14	19.00	12.71	12.77	12.63
		75	0	19.19	19.14	19.11	12.82	12.77	12.74

Band				LTE Band 7					
Antenna Gain (dBi)	-6.37			Conducted Power (dBm)			EIRP Power (dBm)		
Channel Bandwidth (MHz)	Modulation	RB Size	RB Offset	Low CH	Mid CH	High CH	Low CH	Mid CH	High CH
				20850	21100	21350	20850	21100	21350
				2510 MHz	2535 MHz	2560 MHz	2510 MHz	2535 MHz	2560 MHz
20	QPSK	1	0	21.07	21.13	21.01	14.70	14.76	14.64
		1	50	21.18	21.34	21.03	14.81	<b>14.97</b>	14.66
		1	99	21.16	21.01	20.99	14.79	14.64	14.62
		50	0	20.27	20.29	20.07	13.90	13.92	13.70
		50	25	20.21	20.36	20.12	13.84	13.99	13.75
		50	50	20.24	20.23	20.13	13.87	13.86	13.76
		100	0	20.28	20.32	20.14	13.91	13.95	13.77
	16QAM	1	0	20.46	20.51	20.36	14.09	14.14	13.99
		1	50	20.49	20.68	20.34	14.12	<b>14.31</b>	13.97
		1	99	20.50	20.36	20.33	14.13	13.99	13.96
		50	0	19.28	19.39	19.12	12.91	13.02	12.75
		50	25	19.29	19.46	19.21	12.92	13.09	12.84
		50	50	19.19	19.25	19.11	12.82	12.88	12.74
		100	0	19.30	19.25	19.22	12.93	12.88	12.85

Remark: EIRP power = Conducted Power + Antenna gain.

Band				LTE Band 12					
Antenna Gain (dBi)	-3.7			Conducted Power (dBm)			ERP Power (dBm)		
Channel Bandwidth (MHz)	Modulation	RB Size	RB Offset	Low CH	Mid CH	High CH	Low CH	Mid CH	High CH
				23017	23095	23173	23017	23095	23173
				699.7 MHz	707.5 MHz	715.3 MHz	699.7 MHz	707.5 MHz	715.3 MHz
1.4	QPSK	1	0	22.32	22.25	22.20	<b>16.47</b>	16.40	16.35
		1	2	22.20	22.13	22.08	16.35	16.28	16.23
		1	5	22.18	22.11	22.06	16.33	16.26	16.21
		3	0	22.04	21.97	21.92	16.19	16.12	16.07
		3	1	21.99	21.92	21.87	16.14	16.07	16.02
		3	3	22.04	21.97	21.92	16.19	16.12	16.07
	16QAM	1	0	22.30	22.23	22.18	<b>16.45</b>	16.38	16.33
		1	2	22.18	22.11	22.06	16.33	16.26	16.21
		1	5	22.16	22.09	22.04	16.31	16.24	16.19
		3	0	22.02	21.95	21.90	16.17	16.10	16.05
		3	1	21.97	21.90	21.85	16.12	16.05	16.00
		3	3	22.02	21.95	21.90	16.17	16.10	16.05
		6	0	21.16	21.09	21.04	15.31	15.24	15.19

Band				LTE Band 12					
Antenna Gain (dBi)	-3.7			Conducted Power (dBm)			ERP Power (dBm)		
Channel Bandwidth (MHz)	Modulation	RB Size	RB Offset	Low CH	Mid CH	High CH	Low CH	Mid CH	High CH
				23025	23095	23165	23025	23095	23165
				700.5 MHz	707.5 MHz	714.5 MHz	700.5 MHz	707.5 MHz	714.5 MHz
3	QPSK	1	0	22.44	22.37	22.32	<b>16.59</b>	16.52	16.47
		1	7	22.32	22.25	22.20	16.47	16.40	16.35
		1	14	22.30	22.23	22.18	16.45	16.38	16.33
		8	0	21.24	21.17	21.12	15.39	15.32	15.27
		8	3	21.19	21.12	21.07	15.34	15.27	15.22
		8	7	21.24	21.17	21.12	15.39	15.32	15.27
		15	0	21.23	21.16	21.11	15.38	15.31	15.26
	16QAM	1	0	22.31	22.28	22.22	<b>16.46</b>	16.43	16.37
		1	7	22.16	22.13	22.07	16.31	16.28	16.22
		1	14	22.17	22.14	22.08	16.32	16.29	16.23
		8	0	21.18	21.11	21.06	15.33	15.26	15.21
		8	3	21.13	21.06	21.01	15.28	15.21	15.16
		8	7	21.18	21.11	21.06	15.33	15.26	15.21
		15	0	21.17	21.10	21.05	15.32	15.25	15.20

Remark: ERP power = Conducted Power + Antenna gain - 2.15.



Band				LTE Band 12					
Antenna Gain (dBi)	-3.7			Conducted Power (dBm)			ERP Power (dBm)		
Channel Bandwidth (MHz)	Modulation	RB Size	RB Offset	Low CH	Mid CH	High CH	Low CH	Mid CH	High CH
				23035	23095	23155	23035	23095	23155
				701.5 MHz	707.5 MHz	713.5 MHz	701.5 MHz	707.5 MHz	713.5 MHz
5	QPSK	1	0	22.57	22.50	22.45	<b>16.72</b>	16.65	16.60
		1	12	22.45	22.38	22.33	16.60	16.53	16.48
		1	24	22.43	22.36	22.31	16.58	16.51	16.46
		12	0	21.37	21.30	21.25	15.52	15.45	15.40
		12	6	21.32	21.25	21.20	15.47	15.40	15.35
		12	13	21.37	21.30	21.25	15.52	15.45	15.40
	16QAM	25	0	21.36	21.29	21.24	15.51	15.44	15.39
		1	0	21.74	21.71	21.65	<b>15.89</b>	15.86	15.80
		1	12	21.59	21.56	21.50	15.74	15.71	15.65
		1	24	21.60	21.57	21.51	15.75	15.72	15.66
		12	0	20.29	20.26	20.20	14.44	14.41	14.35
		12	6	20.22	20.19	20.13	14.37	14.34	14.28
		12	13	20.28	20.25	20.19	14.43	14.40	14.34
		25	0	20.23	20.20	20.14	14.38	14.35	14.29

Band				LTE Band 12					
Antenna Gain (dBi)	-3.7			Conducted Power (dBm)			ERP Power (dBm)		
Channel Bandwidth (MHz)	Modulation	RB Size	RB Offset	Low CH	Mid CH	High CH	Low CH	Mid CH	High CH
				23060	23095	23130	23060	23095	23130
				704 MHz	707.5 MHz	711 MHz	704 MHz	707.5 MHz	711 MHz
10	QPSK	1	0	22.69	22.62	22.57	<b>16.84</b>	16.77	16.72
		1	24	22.57	22.50	22.45	16.72	16.65	16.60
		1	49	22.55	22.48	22.43	16.70	16.63	16.58
		25	0	21.49	21.42	21.37	15.64	15.57	15.52
		25	12	21.44	21.37	21.32	15.59	15.52	15.47
		25	25	21.49	21.42	21.37	15.64	15.57	15.52
	16QAM	50	0	21.48	21.41	21.36	15.63	15.56	15.51
		1	0	21.86	21.83	21.77	<b>16.01</b>	15.98	15.92
		1	24	21.71	21.68	21.62	15.86	15.83	15.77
		1	49	21.72	21.69	21.63	15.87	15.84	15.78
		25	0	20.41	20.38	20.32	14.56	14.53	14.47
		25	12	20.34	20.31	20.25	14.49	14.46	14.40
		25	25	20.40	20.37	20.31	14.55	14.52	14.46
		50	0	20.35	20.32	20.26	14.50	14.47	14.41

Remark: ERP power = Conducted Power + Antenna gain - 2.15.

Band				LTE Band 13					
Antenna Gain (dBi)	-5.44			Conducted Power (dBm)			ERP Power (dBm)		
Channel Bandwidth (MHz)	Modulation	RB Size	RB Offset	Low CH	Mid CH	High CH	Low CH	Mid CH	High CH
				23205	23230	23255	23205	23230	23255
				779.5 MHz	782 MHz	784.5 MHz	779.5 MHz	782 MHz	784.5 MHz
5	QPSK	1	0	22.23	22.08	22.06	<b>14.64</b>	14.49	14.47
		1	12	22.16	22.01	21.99	14.57	14.42	14.40
		1	24	22.15	22.00	21.98	14.56	14.41	14.39
		12	0	21.17	21.02	21.00	13.58	13.43	13.41
		12	6	21.12	20.97	20.95	13.53	13.38	13.36
		12	13	21.15	21.00	20.98	13.56	13.41	13.39
	16QAM	25	0	21.14	20.99	20.97	13.55	13.40	13.38
		1	0	21.33	21.18	21.16	<b>13.74</b>	13.59	13.57
		1	12	21.17	21.02	21.00	13.58	13.43	13.41
		1	24	21.05	20.90	20.88	13.46	13.31	13.29
		12	0	19.84	19.69	19.67	12.25	12.10	12.08
		12	6	19.83	19.68	19.66	12.24	12.09	12.07
		12	13	19.80	19.65	19.63	12.21	12.06	12.04
		25	0	19.82	19.67	19.65	12.23	12.08	12.06

Band				LTE Band 13	
Antenna Gain (dBi)	-5.44			Conducted Power (dBm)	ERP Power (dBm)
Channel Bandwidth (MHz)	Modulation	RB Size	RB Offset	Mid CH	Mid CH
				23230	23230
				782 MHz	782 MHz
10	QPSK	1	0	22.30	<b>14.71</b>
		1	24	22.13	14.54
		1	49	22.12	14.53
		25	0	21.14	13.55
		25	12	21.09	13.50
		25	25	21.12	13.53
		50	0	21.11	13.52
	16QAM	1	0	21.59	<b>14.00</b>
		1	24	21.43	13.84
		1	49	21.31	13.72
		25	0	20.10	12.51
		25	12	20.09	12.50
		25	25	20.06	12.47
		50	0	20.08	12.49

Remark: ERP power = Conducted Power + Antenna gain - 2.15.

Band				LTE Band 30					
Antenna Gain (dBi)	-5.27			Conducted Power (dBm)			EIRP Power (dBm)		
Channel Bandwidth (MHz)	Modulation	RB Size	RB Offset	Low CH	Mid CH	High CH	Low CH	Mid CH	High CH
				27685	27710	27735	27685	27710	27735
				2307.5 MHz	2310 MHz	2312.5 MHz	2307.5 MHz	2310 MHz	2312.5 MHz
5	QPSK	1	0	21.52	21.47	21.50	<b>16.25</b>	16.20	16.23
		1	12	21.42	21.46	21.40	16.15	16.19	16.13
		1	24	21.29	21.33	21.27	16.02	16.06	16.00
		12	0	20.43	20.47	20.41	15.16	15.20	15.14
		12	6	20.42	20.46	20.40	15.15	15.19	15.13
		12	13	20.23	20.27	20.21	14.96	15.00	14.94
	16QAM	25	0	20.34	20.38	20.32	15.07	15.11	15.05
		1	0	20.83	20.87	20.81	15.56	15.60	15.54
		1	12	20.86	20.90	20.84	15.59	<b>15.63</b>	15.57
		1	24	20.65	20.69	20.63	15.38	15.42	15.36
		12	0	19.45	19.49	19.43	14.18	14.22	14.16
		12	6	19.42	19.46	19.40	14.15	14.19	14.13
		12	13	19.24	19.28	19.22	13.97	14.01	13.95
		25	0	19.35	19.39	19.33	14.08	14.12	14.06

Band				LTE Band 30	
Antenna Gain (dBi)	-5.27			Conducted Power (dBm)	EIRP Power (dBm)
Channel Bandwidth (MHz)	Modulation	RB Size	RB Offset	Mid CH	Mid CH
				27710	27710
				2310 MHz	2310 MHz
10	QPSK	1	0	21.63	<b>16.36</b>
		1	24	21.53	16.26
		1	49	21.40	16.13
		25	0	20.54	15.27
		25	12	20.53	15.26
		25	25	20.34	15.07
		50	0	20.45	15.18
	16QAM	1	0	20.94	15.67
		1	24	20.97	<b>15.70</b>
		1	49	20.76	15.49
		25	0	19.56	14.29
		25	12	19.53	14.26
		25	25	19.35	14.08
		50	0	19.46	14.19

Remark: EIRP power = Conducted Power + Antenna gain.

Band				LTE Band 41									
Antenna Gain (dBi)	-5.57			Conducted Power (dBm)					EIRP Power (dBm)				
Channel Bandwidth (MHz)	Modulation	RB Size	RB Offset	Low CH	Mid CH	Mid CH	Mid CH	High CH	Low CH	Mid CH	Mid CH	Mid CH	High CH
				39675	40148	40620	41093	41565	39675	40148	40620	41093	41565
5	QPSK	1	0	20.88	20.88	21.09	20.80	20.87	15.31	15.31	15.52	15.23	15.30
		1	12	21.12	20.85	21.01	20.91	20.81	<b>15.55</b>	15.28	15.44	15.34	15.24
		1	24	20.91	20.54	20.80	20.79	20.70	15.34	14.97	15.23	15.22	15.13
		12	0	20.02	19.80	20.08	19.92	20.08	14.45	14.23	14.51	14.35	14.51
		12	6	19.97	19.82	20.12	20.03	20.02	14.40	14.25	14.55	14.46	14.45
		12	13	19.89	19.80	20.04	19.96	19.93	14.32	14.23	14.47	14.39	14.36
	16QAM	1	0	20.22	20.21	20.21	20.18	20.40	14.65	14.64	14.64	14.61	<b>14.83</b>
		1	12	20.37	20.18	20.38	20.31	20.29	14.80	14.61	14.81	14.74	14.72
		1	24	20.10	19.94	20.21	20.16	20.23	14.53	14.37	14.64	14.59	14.66
		12	0	19.04	18.84	19.11	18.96	19.12	13.47	13.27	13.54	13.39	13.55
		12	6	19.07	18.88	19.17	19.11	19.04	13.50	13.31	13.60	13.54	13.47
		12	13	18.95	18.79	19.10	19.06	18.93	13.38	13.22	13.53	13.49	13.36
		25	0	19.01	18.82	19.11	18.96	19.02	13.44	13.25	13.54	13.39	13.45

Band				LTE Band 41									
Antenna Gain (dBi)	-5.57			Conducted Power (dBm)					EIRP Power (dBm)				
Channel Bandwidth (MHz)	Modulation	RB Size	RB Offset	Low CH	Mid CH	Mid CH	Mid CH	High CH	Low CH	Mid CH	Mid CH	Mid CH	High CH
				39700	40160	40620	41080	41540	39700	40160	40620	41080	41540
10	QPSK	1	0	20.99	20.89	21.20	20.91	20.98	15.42	15.32	15.63	15.34	15.41
		1	24	21.23	20.96	21.12	21.02	20.92	<b>15.66</b>	15.39	15.55	15.45	15.35
		1	49	21.02	20.65	20.91	20.90	20.81	15.45	15.08	15.34	15.33	15.24
		25	0	20.13	19.91	20.19	20.03	20.19	14.56	14.34	14.62	14.46	14.62
		25	12	20.08	19.93	20.23	20.14	20.13	14.51	14.36	14.66	14.57	14.56
		25	25	20.00	19.91	20.15	20.07	20.04	14.43	14.34	14.58	14.50	14.47
	16QAM	50	0	20.04	19.87	20.21	20.00	20.05	14.47	14.30	14.64	14.43	14.48
		1	0	20.33	20.32	20.32	20.29	20.51	14.76	14.75	14.75	14.72	<b>14.94</b>
		1	24	20.48	20.29	20.49	20.42	20.40	14.91	14.72	14.92	14.85	14.83
		1	49	20.21	20.05	20.32	20.27	20.34	14.64	14.48	14.75	14.70	14.77
		25	0	19.15	18.95	19.22	19.07	19.23	13.58	13.38	13.65	13.50	13.66
		25	12	19.18	18.99	19.28	19.22	19.15	13.61	13.42	13.71	13.65	13.58
		25	25	19.06	18.90	19.21	19.17	19.04	13.49	13.33	13.64	13.60	13.47
		50	0	19.12	18.93	19.22	19.07	19.13	13.55	13.36	13.65	13.50	13.56

Remark: EIRP power = Conducted Power + Antenna gain.

Band				LTE Band 41									
Antenna Gain (dBi)	-5.57			Conducted Power (dBm)					EIRP Power (dBm)				
Channel Bandwidth (MHz)	Modulation	RB Size	RB Offset	Low CH	Mid CH	Mid CH	Mid CH	High CH	Low CH	Mid CH	Mid CH	Mid CH	High CH
				39725	40173	40620	41068	41515	39725	40173	40620	41068	41515
15	QPSK	1	0	21.11	21.11	21.32	21.03	21.10	15.54	15.54	15.75	15.46	15.53
		1	37	21.35	21.08	21.24	21.14	21.04	<b>15.78</b>	15.51	15.67	15.57	15.47
		1	74	21.14	20.77	21.03	21.02	20.93	15.57	15.20	15.46	15.45	15.36
		36	0	20.25	20.03	20.31	20.15	20.31	14.68	14.46	14.74	14.58	14.74
		36	19	20.20	20.05	20.35	20.26	20.25	14.63	14.48	14.78	14.69	14.68
		36	39	20.12	20.03	20.27	20.19	20.16	14.55	14.46	14.70	14.62	14.59
	16QAM	1	0	20.45	20.44	20.44	20.41	20.63	14.88	14.87	14.87	14.84	<b>15.06</b>
		1	37	20.60	20.41	20.61	20.54	20.52	15.03	14.84	15.04	14.97	14.95
		1	74	20.33	20.17	20.44	20.39	20.46	14.76	14.60	14.87	14.82	14.89
		36	0	19.27	19.07	19.34	19.19	19.35	13.70	13.50	13.77	13.62	13.78
		36	19	19.30	19.11	19.40	19.34	19.27	13.73	13.54	13.83	13.77	13.70
		36	39	19.18	19.02	19.33	19.29	19.16	13.61	13.45	13.76	13.72	13.59
		75	0	19.24	19.05	19.34	19.19	19.25	13.67	13.48	13.77	13.62	13.68

Band				LTE Band 41									
Antenna Gain (dBi)	-5.57			Conducted Power (dBm)					EIRP Power (dBm)				
Channel Bandwidth (MHz)	Modulation	RB Size	RB Offset	Low CH	Mid CH	Mid CH	Mid CH	High CH	Low CH	Mid CH	Mid CH	Mid CH	High CH
				39750	40185	40620	41055	41490	39750	40185	40620	41055	41490
20	QPSK	1	0	21.23	21.23	21.44	21.15	21.22	15.66	15.66	15.87	15.58	15.65
		1	50	21.47	21.20	21.36	21.26	21.16	<b>15.90</b>	15.63	15.79	15.69	15.59
		1	99	21.26	20.89	21.15	21.14	21.05	15.69	15.32	15.58	15.57	15.48
		50	0	20.37	20.15	20.43	20.27	20.43	14.80	14.58	14.86	14.70	14.86
		50	25	20.32	20.17	20.47	20.38	20.37	14.75	14.60	14.90	14.81	14.80
		50	50	20.24	20.15	20.39	20.31	20.28	14.67	14.58	14.82	14.74	14.71
	16QAM	100	0	20.28	20.11	20.45	20.24	20.29	14.71	14.54	14.88	14.67	14.72
		1	0	20.57	20.56	20.56	20.53	20.75	15.00	14.99	14.99	14.96	<b>15.18</b>
		1	50	20.72	20.53	20.73	20.66	20.64	15.15	14.96	15.16	15.09	15.07
		1	99	20.45	20.29	20.56	20.51	20.58	14.88	14.72	14.99	14.94	15.01
		50	0	19.39	19.19	19.46	19.31	19.47	13.82	13.62	13.89	13.74	13.90
		50	25	19.42	19.23	19.52	19.46	19.39	13.85	13.66	13.95	13.89	13.82
		50	50	19.30	19.14	19.45	19.41	19.28	13.73	13.57	13.88	13.84	13.71
		100	0	19.36	19.17	19.46	19.31	19.37	13.79	13.60	13.89	13.74	13.80

Remark: EIRP power = Conducted Power + Antenna gain.

## APPENDIX B PEAK-TO-AVERAGE RATIO (PAR)

CONTINUE ON NEXT PAGE

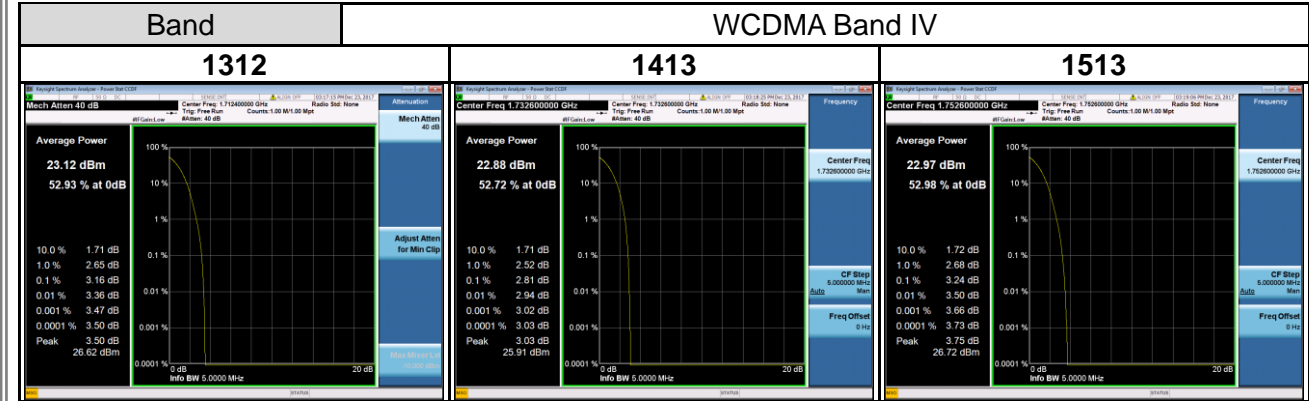

Band	LTE Band 4		
Channel Bandwidth (MHz)	1.4	Modulation	QPSK

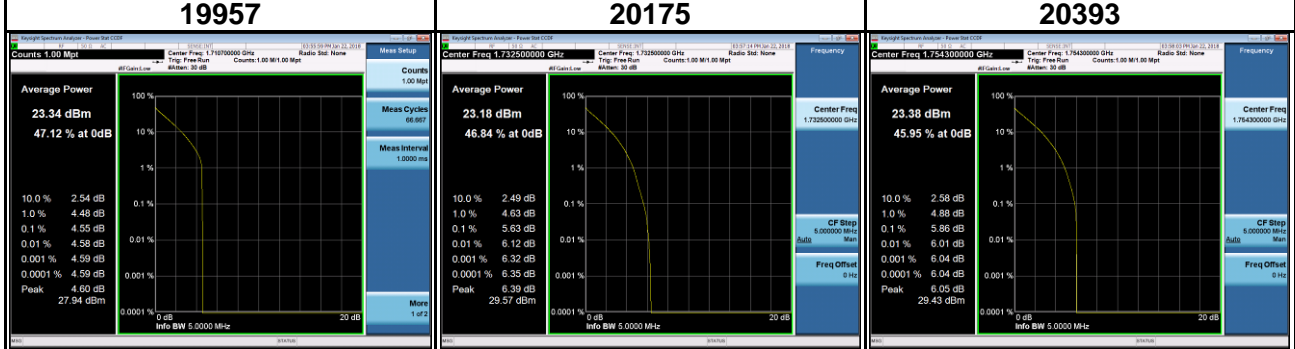

Band	LTE Band 4		
Channel Bandwidth (MHz)	1.4	Modulation	16QAM

