



# FCC RADIO TEST REPORT

## FCC ID: M7CMID010

**Product :** MID

**Trade Name :** HENA,GPX

**Model Name :** MID7326CM

MID7326RM, MID7326CE, MID7326RE,

**Serial Model :** MID73\*\*CM, MID73\*\*RM, MID73\*\*CE,  
MID73\*\*RE (\*\*can be 01-99)

**Report No. :** NTEK- 2012NT1009053F

### Prepared for

Hena Digital Technology (Shenzhen) Co., Ltd.

3F, South Tower, Jiuzhou Electric Building, Southern No, 12Rd,  
High-tech Industrial Park, Nanshan District, Shenzhen, China

### Prepared by

Shenzhen NTEK Testing Technology Co., Ltd.

1/F, Building E, Fenda Science Park, Sanwei Community, Xixiang Street  
Bao'an District, Shenzhen P.R. China

Tel.: +86-0755-61156588 Fax.: +86-0755-61156599

Website: [www.ntek.org.cn](http://www.ntek.org.cn)

## TEST RESULT CERTIFICATION

**Applicant's name** ..... : Hena Digital Technology (Shenzhen) Co., Ltd.  
**Address** ..... : 3F, South Tower, Jiuzhou Electric Building, Southern No, 12Rd,  
High-tech Industrial Park, Nanshan District, Shenzhen, China  
**Manufacture's Name**..... : Hena Digital Technology (Shenzhen) Co., Ltd.  
**Address** ..... : 3F, South Tower, Jiuzhou Electric Building, Southern No, 12Rd,  
High-tech Industrial Park, Nanshan District, Shenzhen, China

### Product description

**Product name** ..... : MID  
**Model and/or type reference** : MID7326CM  
**Serial Model** ..... : MID7326RM, MID7326CE, MID7326RE, MID73\*\*CM,  
MID73\*\*RM, MID73\*\*CE, MID73\*\*RE (\*\*can be 01-99)

**Standards** ..... : FCC Part15.247

**Test procedure** ..... ANSI C63.4-2003

This device described above has been tested by NTEK, and the test results show that the equipment under test (EUT) is in compliance with the FCC requirements. And it is applicable only to the tested sample identified in the report.

This report shall not be reproduced except in full, without the written approval of NTEK, this document may be altered or revised by NTEK, personal only, and shall be noted in the revision of the document.

**Date of Test** .....

**Date (s) of performance of tests** ..... : 09 Oct. 2012 ~22 Oct. 2012

**Date of Issue**..... : 22 Oct. 2012

**Test Result**..... : **Pass**

**Testing Engineer** : Jason Chen  
(Jason Chen)

**Technical Manager** : Tom Zhang  
(Tom Zhang)

**Authorized Signatory** : Bovey Yang  
(Bovey Yang)

**Table of Contents**

	<b>Page</b>
<b>1 . SUMMARY OF TEST RESULTS</b>	<b>5</b>
1.1 TEST FACILITY	6
1.2 MEASUREMENT UNCERTAINTY	6
<b>2 . GENERAL INFORMATION</b>	<b>7</b>
2.1 GENERAL DESCRIPTION OF EUT	7
2.2 DESCRIPTION OF TEST MODES	9
2.3 BLOCK DIGRAM SHOWING THE CONFIGURATION OF SYSTEM TESTED	10
2.4 DESCRIPTION OF SUPPORT UNITS(CONDUCTED MODE)	11
2.5 EQUIPMENTS LIST FOR ALL TEST ITEMS	12
<b>3 . EMC EMISSION TEST</b>	<b>13</b>
3.1 CONDUCTED EMISSION MEASUREMENT	13
3.1.1 POWER LINE CONDUCTED EMISSION LIMITS	13
3.1.2 TEST PROCEDURE	14
3.1.3 DEVIATION FROM TEST STANDARD	14
3.1.4 TEST SETUP	14
3.1.5 EUT OPERATING CONDITIONS	14
3.1.6 TEST RESULTS	15
3.2 RADIATED EMISSION MEASUREMENT	17
3.2.1 RADIATED EMISSION LIMITS	17
3.2.2 TEST PROCEDURE	18
3.2.3 DEVIATION FROM TEST STANDARD	18
3.2.4 TEST SETUP	19
3.2.5 EUT OPERATING CONDITIONS	20
3.2.6 TEST RESULTS (BETWEEN 9KHZ – 30 MHZ)	21
3.2.7 TEST RESULTS (BETWEEN 30MHZ – 1GHZ)	22
3.2.8 TEST RESULTS (ABOVE 1000 MHZ)	24
<b>4 . POWER SPECTRAL DENSITY TEST</b>	<b>56</b>
4.1 APPLIED PROCEDURES / LIMIT	56
4.1.1 TEST PROCEDURE	56
4.1.2 DEVIATION FROM STANDARD	56
4.1.3 TEST SETUP	56
4.1.4 EUT OPERATION CONDITIONS	56
4.1.5 TEST RESULTS	57
<b>5 . BANDWIDTH TEST</b>	<b>65</b>
5.1 APPLIED PROCEDURES / LIMIT	65
5.1.1 TEST PROCEDURE	65

**Table of Contents**

	<b>Page</b>
5.1.2 DEVIATION FROM STANDARD	65
5.1.3 TEST SETUP	65
5.1.4 EUT OPERATION CONDITIONS	65
5.1.5 TEST RESULTS	66
<b>6 . PEAK OUTPUT POWER TEST</b>	<b>74</b>
6.1 APPLIED PROCEDURES / LIMIT	74
6.1.1 TEST PROCEDURE	74
6.1.2 DEVIATION FROM STANDARD	74
6.1.3 TEST SETUP	74
6.1.4 EUT OPERATION CONDITIONS	74
6.1.5 TEST RESULTS	75
<b>7 . ANTENNA REQUIREMENT</b>	<b>76</b>
7.1 STANDARD REQUIREMENT	76
7.2 EUT ANTENNA	76
<b>8 . EUT TEST PHOTO</b>	<b>77</b>
<b>APPENDIX-PHOTOGRAPHS OF EUT CONSTRUCTIONAL DETAILS</b>	

### 1. SUMMARY OF TEST RESULTS

Test procedures according to the technical standards:

FCC Part15 (15.247) , Subpart C			
Standard Section	Test Item	Judgment	Remark
15.207	Conducted Emission	PASS	
15.247 (a)(2)	6dB Bandwidth	PASS	
15.247 (b)	Peak Output Power	PASS	
15.247 (c)	Radiated Spurious Emission	PASS	
15.247 (d)	Power Spectral Density	PASS	
15.205	Band Edge Emission	PASS	
15.203	Antenna Requirement	PASS	

**NOTE:**

(1) "N/A" denotes test is not applicable in this Test Report

**1.1 TEST FACILITY**

Shenzhen NTEK Testing Technology Co., Ltd  
 Add.:1/F, Building E, Fenda Science Park, Sanwei Community, Xixiang Street, Bao'an District, Shenzhen P.R. China.  
 FCC Registration No.:238937; IC Registration No.:9270A-1  
 CNAS Registration No.:L5516

**1.2 MEASUREMENT UNCERTAINTY**

The reported uncertainty of measurement  $y \pm U$ , where expanded uncertainty  $U$  is based on a standard uncertainty multiplied by a coverage factor of  $k=2$ , providing a level of confidence of approximately 95 %.

No.	Item	Uncertainty
1	Conducted Emission Test	$\pm 1.38\text{dB}$
2	RF power,conducted	$\pm 0.16\text{dB}$
3	Spurious emissions,conducted	$\pm 0.21\text{dB}$
4	All emissions,radiated(<1G)	$\pm 4.68\text{dB}$
5	All emissions,radiated(>1G)	$\pm 4.89\text{dB}$
6	Temperature	$\pm 0.5^\circ\text{C}$
7	Humidity	$\pm 2\%$

## 2. GENERAL INFORMATION

### 2.1 GENERAL DESCRIPTION OF EUT

Equipment	MID	
Trade Name	HENA,GPX	
Model Name	MID7326CM	
Serial Model	MID7326RM, MID7326CE, MID7326RE, MID73**CM, MID73**RM, MID73**CE, MID73**RE (**can be 01-99)	
Model Difference	Only Model name is different.	
Product Description	The EUT is a MID	
	Operation Frequency:	2412~2462 MHz
	Modulation Type:	CCK/OFDM/DBPSK/DAPSK
	Bit Rate of Transmitter	802.11b:11/5.5/2/1 Mbps 802.11g:54/48/36/24/18/12/9/6 Mbps 802.11n(20MHz):150/144.44/130/117/115.56/104/86.67/78/52/6.5 Mbps 802.11n(40MHz):270/240/180/150/120/108/90/54 Mbps
	Number Of Channel	11 CH, Please see Note 2.
	Antenna Designation:	Please see Note 3.
	Output Power(Conducted):	802.11b: 9.10 dBm (Max.) 802.11g: 8.81 dBm (Max.) 802.11n(20M) : 9.27 dBm (Max.) 802.11n(40M) : 9.04 dBm (Max.)
	Antenna Gain (dBi)	2dBi
Based on the application, features, or specification exhibited in User's Manual, the EUT is considered as an ITE/Computing Device. More details of EUT technical specification, please refer to the User's Manual.		
Channel List	Please refer to the Note 2.	
Ratings	DC 5V From Adapter AC 120V/60Hz	
Adapter	Model: SEF050200A1BA, AC Power Input: 100-240V~, 50/60Hz, 0.5A Output: 5.0V  2000mA	
Battery	DC 5V From Adapter AC 120V/60Hz	

Note:

1. For a more detailed features description, please refer to the manufacturer's specifications or the User's Manual.

2.

Channel List for 802.11b/g/n(20MHz)							
Channel	Frequency (MHz)	Channel	Frequency (MHz)	Channel	Frequency (MHz)	Channel	Frequency (MHz)
01	2412	04	2427	07	2442	10	2457
02	2417	05	2432	08	2447	11	2462
03	2422	06	2437	09	2452		

Channel List for 802.11n(40MHz)							
Channel	Frequency (MHz)	Channel	Frequency (MHz)	Channel	Frequency (MHz)	Channel	Frequency (MHz)
03	2422	06	2437	09	2452		
04	2427	07	2442				
05	2432	08	2447				

3.

Table for Filed Antenna

Ant	Brand	Model Name	Antenna Type	Connector	Gain (dBi)	NOTE
A	N/A	N/A	FPCB-Ant	N/A	2.0	N/A



## 2.2 DESCRIPTION OF TEST MODES

To investigate the maximum EMI emission characteristics generates from EUT, the test system was pre-scanning tested base on the consideration of following EUT operation mode or test configuration mode which possible have effect on EMI emission level. Each of these EUT operation mode(s) or test configuration mode(s) mentioned above was evaluated respectively.

Pretest Mode	Description
Mode 1	802.11b CH1/ CH6/ CH11, 1 Mbps data rate
Mode 2	802.11g CH1/ CH6/ CH11, 6 Mbps data rate
Mode 3	802.11n(20) CH1/ CH6/ CH11, 6.5 Mbps data rate
Mode 4	802.11n(40) CH3/ CH6/ CH9, 54 Mbps data rate
Mode 5	Charging+ Link

For Conducted Emission	
Final Test Mode	Description
Mode 5	Charging+ Link

For Radiated Emission	
Final Test Mode	Description
Mode 1	802.11b CH1/ CH6/ CH11, 1 Mbps data rate
Mode 2	802.11g CH1/ CH6/ CH11, 6 Mbps data rate
Mode 3	802.11n(20) CH1/ CH6/ CH11, 6.5 Mbps data rate
Mode 4	802.11n(40) CH3/ CH6/ CH9, 54 Mbps data rate

Note:

- (1) The measurements are performed at the highest, middle, lowest available channels.
- (2) The measurements are performed at all Bit Rate of Transmitter, the worst data was reported
- (3) The test results is to use the lowest bit rate, is the worst.

**2.3 BLOCK DIGRAM SHOWING THE CONFIGURATION OF SYSTEM TESTED**

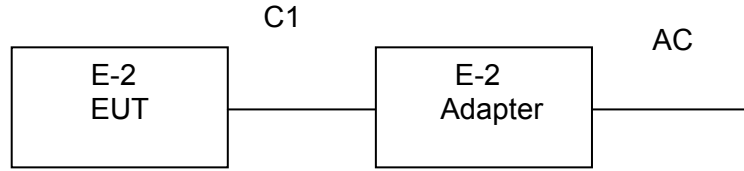

**2.4 DESCRIPTION OF SUPPORT UNITS(CONDUCTED MODE)**

The EUT has been tested as an independent unit together with other necessary accessories or support units. The following support units or accessories were used to form a representative test configuration during the tests.

Item	Equipment	Mfr/Brand	Model/Type No.	Series No.	Note
E-1	MID	N/A	MID7326CM	N/A	EUT
E-2	Adapter	N/A	SEF0500200A1SA	N/A	

Item	Shielded Type	Ferrite Core	Length	Note
C1	NO	NO	0.8M	DC Line

Note:

- (1) The support equipment was authorized by Declaration of Confirmation.
- (2) For detachable type I/O cable should be specified the length in cm in 『Length』 column.

**2.5 EQUIPMENTS LIST FOR ALL TEST ITEMS**

**Radiation Test equipment**

Item	Kind of Equipment	Manufacturer	Type No.	Serial No.	Calibrated until
1	Spectrum Analyzer	Agilent	E4407B	160400005	Jul. 06. 2013
2	Test Receiver	R&S	ESPI	101318	Jul. 06. 2013
3	Bilog Antenna	TESEQ	CBL6111D	31216	Jul. 06. 2013
4	50Ω Coaxial Switch	Anritsu	MP59B	6200264416	Jul. 06. 2013
5	Spectrum Analyzer	ADVANTEST	R3132	150900201	Jul. 06. 2013
6	Horn Antenna	EM	EM-AH-10180	2011071402	Jul. 06. 2013
7	Horn Ant	Schwarzbeck	BBHA 9170	9170-181	Jul. 06. 2013
8	Amplifier	EM	EM-30180	060538	Jul. 06. 2013
9	Loop Antenna	ARA	PLA-1030/B	1029	Jul. 06. 2013
10	Power Meter	R&S	NRVS	100696	Jul. 06. 2013

**Conduction Test equipment**

Item	Kind of Equipment	Manufacturer	Type No.	Serial No.	Calibrated until
1	Test Receiver	R&S	ESCI	101160	Jul. 06. 2013
2	LISN	R&S	ENV216	101313	Jul. 06. 2013
3	LISN	EMCO	3816/2	00042990	Jul. 06. 2013
4	50Ω Coaxial Switch	Anritsu	MP59B	6200264417	Jul. 06. 2013
5	Passive Voltage Probe	R&S	ESH2-Z3	100196	Jul. 06. 2013
6	Absorbing clamp	R&S	MOS-21	100423	Jul. 06. 2013

### 3. EMC EMISSION TEST

#### 3.1 CONDUCTED EMISSION MEASUREMENT

##### 3.1.1 POWER LINE CONDUCTED EMISSION Limits (Frequency Range 150KHz-30MHz)

FREQUENCY (MHz)	Class A (dBuV)		Class B (dBuV)		Standard
	Quasi-peak	Average	Quasi-peak	Average	
0.15 -0.5	79.00	66.00	66 - 56 *	56 - 46 *	CISPR
0.50 -5.0	73.00	60.00	56.00	46.00	CISPR
5.0 -30.0	73.00	60.00	60.00	50.00	CISPR

0.15 -0.5	79.00	66.00	66 - 56 *	56 - 46 *	FCC
0.50 -5.0	73.00	60.00	56.00	46.00	FCC
5.0 -30.0	73.00	60.00	60.00	50.00	FCC

Note:

- (1) The tighter limit applies at the band edges.
- (2) The limit of " \* " marked band means the limitation decreases linearly with the logarithm of the frequency in the range.

The following table is the setting of the receiver

Receiver Parameters	Setting
Attenuation	10 dB
Start Frequency	0.15 MHz
Stop Frequency	30 MHz
IF Bandwidth	9 kHz

**3.1.2 TEST PROCEDURE**

- a. The EUT was placed 0.4 meters from the horizontal ground plane with EUT being connected to the power mains through a line impedance stabilization network (LISN). All other support equipments powered from additional LISN(s). The LISN provide 50 Ohm/ 50uH of coupling impedance for the measuring instrument.
- b. Interconnecting cables that hang closer than 40 cm to the ground plane shall be folded back and forth in the center forming a bundle 30 to 40 cm long.
- c. I/O cables that are not connected to a peripheral shall be bundled in the center. The end of the cable may be terminated, if required, using the correct terminating impedance. The overall length shall not exceed 1 m.
- d. LISN at least 80 cm from nearest part of EUT chassis.
- e. For the actual test configuration, please refer to the related Item –EUT Test Photos.

**3.1.3 DEVIATION FROM TEST STANDARD**

No deviation

**3.1.4 TEST SETUP**

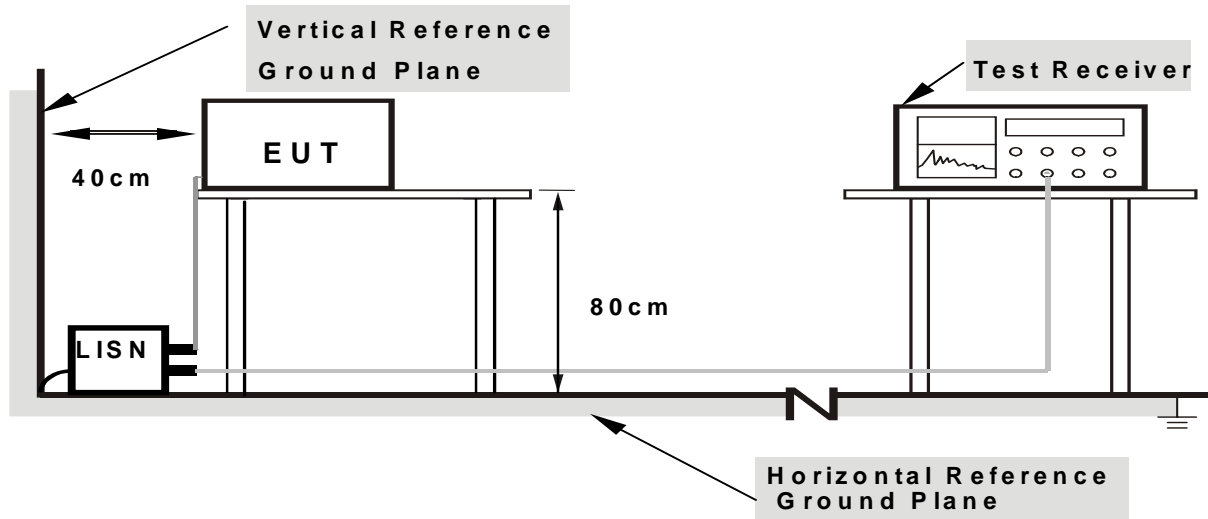

- Note:**
- 1. Support units were connected to second LISN.
  - 2. Both of LISNs (AMN) are 80 cm from EUT and at least 80 from other units and other metal planes

**3.1.5 EUT OPERATING CONDITIONS**

The EUT was configured for testing in a typical fashion (as a customer would normally use it). The EUT has been programmed to continuously transmit during test. This operating condition was tested and used to collect the included data.

### 3.1.6 TEST RESULTS

EUT :	MID	Model Name. :	MID7326CM
Temperature :	26 °C	Relative Humidity :	54%
Pressure :	1010hPa	Phase :	L
Test Voltage :	DC 5V From Adapter AC 120V/60Hz	Test Mode :	Mode 5

Frequency (MHz)	Meter Reading (dBμV)	Factor (dB)	Emission Level (dBμV)	Limits (dBμV)	Margin (dB)	Detector Type
0.2020	42.99	10.20	53.19	63.52	-10.33	QP
0.2020	31.92	10.20	42.12	53.52	-11.40	AVG
0.2779	35.90	10.20	46.10	60.88	-14.78	AVG
0.2779	24.39	10.20	34.59	50.88	-16.29	QP
29.6980	21.89	10.69	32.58	50.00	-17.42	QP

**Remark:**

1. All readings are Quasi-Peak and Average values.
2. Factor = Insertion Loss + Cable Loss.

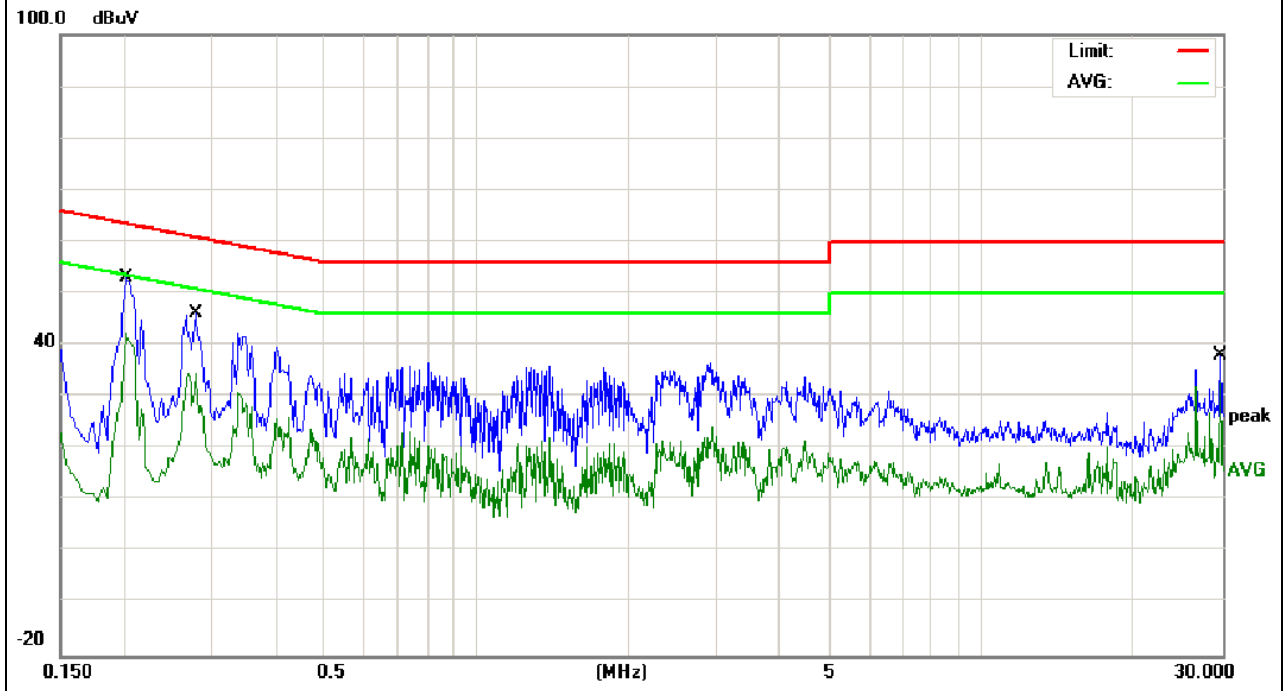

EUT :	MID	Model Name. :	MID7326CM
Temperature :	26 °C	Relative Humidity :	54%
Pressure :	1010hPa	Phase :	N
Test Voltage :	DC 5V From Adapter AC 120V/60Hz	Test Mode :	Mode 5

Frequency (MHz)	Meter Reading (dBμV)	Factor (dB)	Emission Level (dBμV)	Limits (dBμV)	Margin (dB)	Detector Type
0.2099	29.28	9.78	39.06	53.21	-14.15	QP
0.2100	42.01	9.78	51.79	63.20	-11.41	QP
0.2100	29.28	9.78	39.06	53.20	-14.14	AVG
0.2700	36.07	9.87	45.94	61.12	-15.18	QP
0.2700	25.09	9.87	34.96	51.12	-16.16	AVG

Remark:

1. All readings are Quasi-Peak and Average values.
2. Factor = Insertion Loss + Cable Loss.

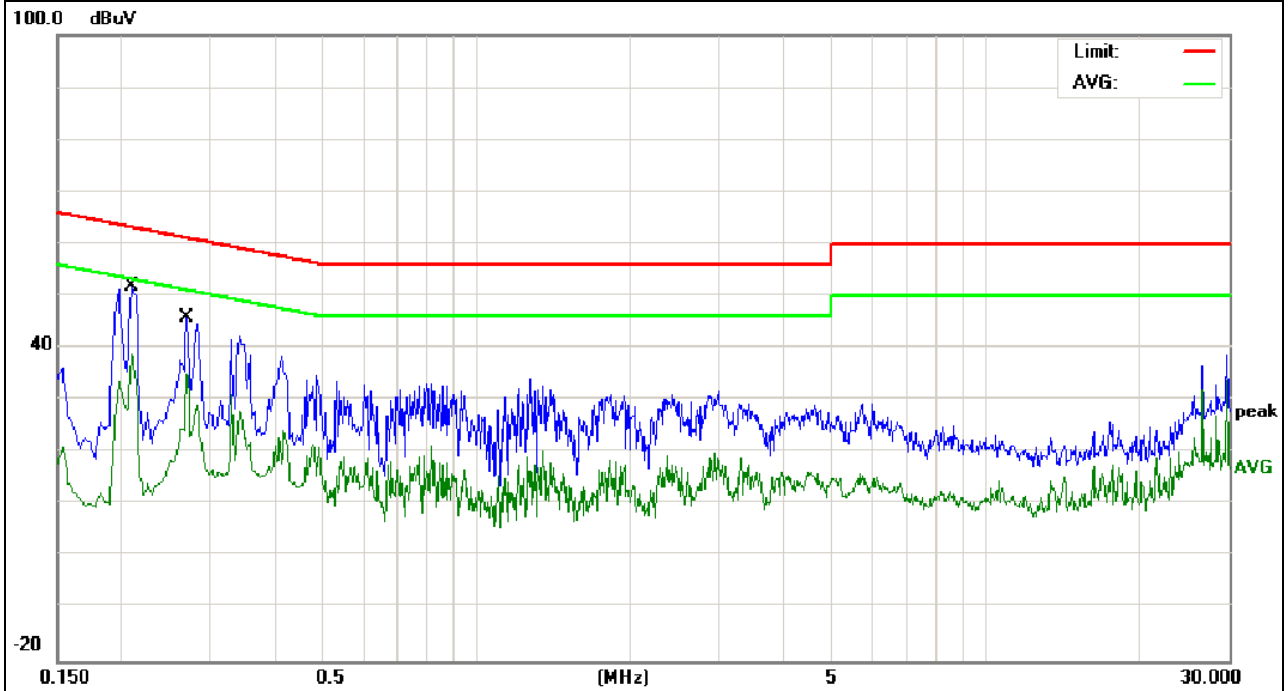



### 3.2 RADIATED EMISSION MEASUREMENT

#### 3.2.1 RADIATED EMISSION LIMITS (Frequency Range 9kHz-1000MHz)

20dBc in any 100 kHz bandwidth outside the operating frequency band. In case the emission fall within the restricted band specified on 15.205(a), then the 15.209(a) limit in the table below has to be followed.

Frequencies (MHz)	Field Strength (micovolts/meter)	Measurement Distance (meters)
0.009~0.490	2400/F(KHz)	300
0.490~1.705	24000/F(KHz)	30
1.705~30.0	30	30
30~88	100	3
88~216	150	3
216~960	200	3
Above 960	500	3

#### LIMITS OF RADIATED EMISSION MEASUREMENT (Above 1000MHz)

FREQUENCY (MHz)	Class A (dBuV/m) (at 3M)		Class B (dBuV/m) (at 3M)	
	PEAK	AVERAGE	PEAK	AVERAGE
Above 1000	80	60	74	54

Notes:

- (1) The limit for radiated test was performed according to FCC PART 15C.
- (2) The tighter limit applies at the band edges.
- (3) Emission level (dBuV/m)=20log Emission level (uV/m).

Spectrum Parameter	Setting
Attenuation	Auto
Start Frequency	1000 MHz
Stop Frequency	10th carrier harmonic
RB / VB (emission in restricted band)	1 MHz / 1 MHz for Peak, 1 MHz / 10Hz for Average

Receiver Parameter	Setting
Attenuation	Auto
Start ~ Stop Frequency	9kHz~150kHz / RB 200Hz for QP
Start ~ Stop Frequency	150kHz~30MHz / RB 9kHz for QP
Start ~ Stop Frequency	30MHz~1000MHz / RB 120kHz for QP

### 3.2.2 TEST PROCEDURE

- a. The measuring distance of at 3 m shall be used for measurements at frequency up to 1GHz. For frequencies above 1GHz, any suitable measuring distance may be used.
- b. The EUT was placed on the top of a rotating table 0.8 meters above the ground at a 3 meter open area test site. The table was rotated 360 degrees to determine the position of the highest radiation.
- c. The height of the equipment or of the substitution antenna shall be 0.8 m; the height of the test antenna shall vary between 1 m to 4 m. Both horizontal and vertical polarizations of the antenna are set to make the measurement.
- d. The initial step in collecting conducted emission data is a spectrum analyzer peak detector mode pre-scanning the measurement frequency range. Significant peaks are then marked and then Quasi Peak detector mode re-measured.
- e. If the Peak Mode measured value compliance with and lower than Quasi Peak Mode Limit, the EUT shall be deemed to meet QP Limits and then no additional QP Mode measurement performed.
- f. For the actual test configuration, please refer to the related Item –EUT Test Photos.

Note:

Both horizontal and vertical antenna polarities were tested and performed pretest to three orthogonal axis. The worst case emissions were reported

### 3.2.3 DEVIATION FROM TEST STANDARD

No deviation

### 3.2.4 TEST SETUP

#### (A) Radiated Emission Test-Up Frequency Below 30MHz

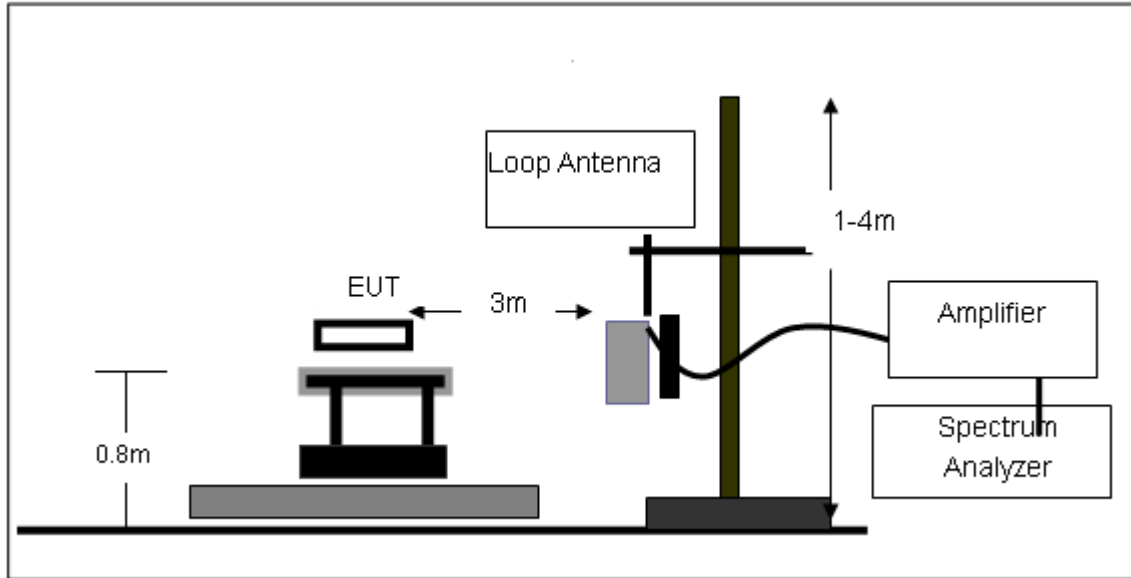

#### (B) Radiated Emission Test-Up Frequency 30MHz~1GHz

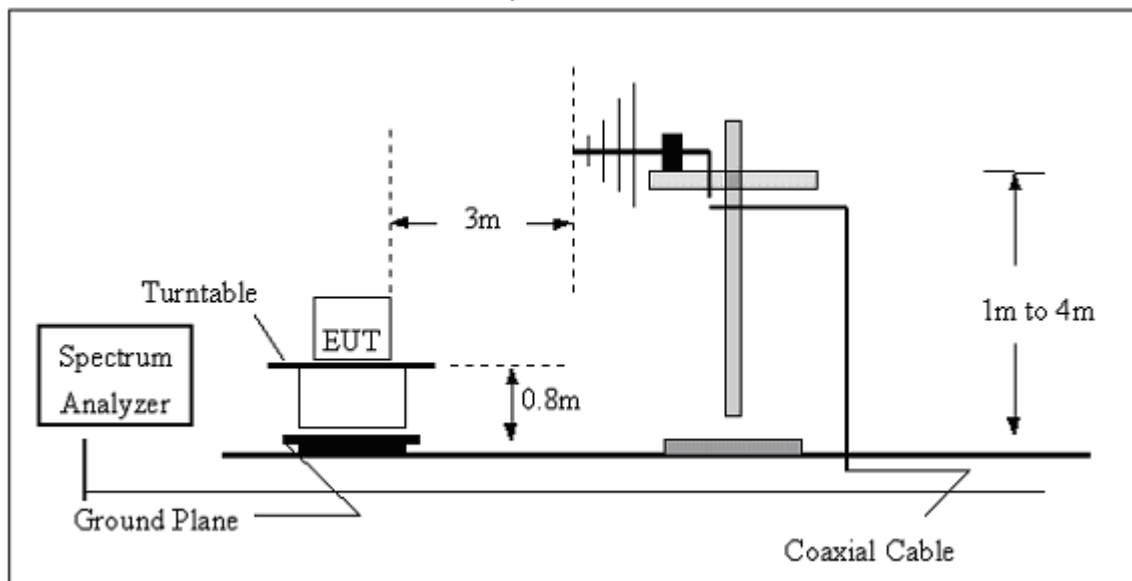

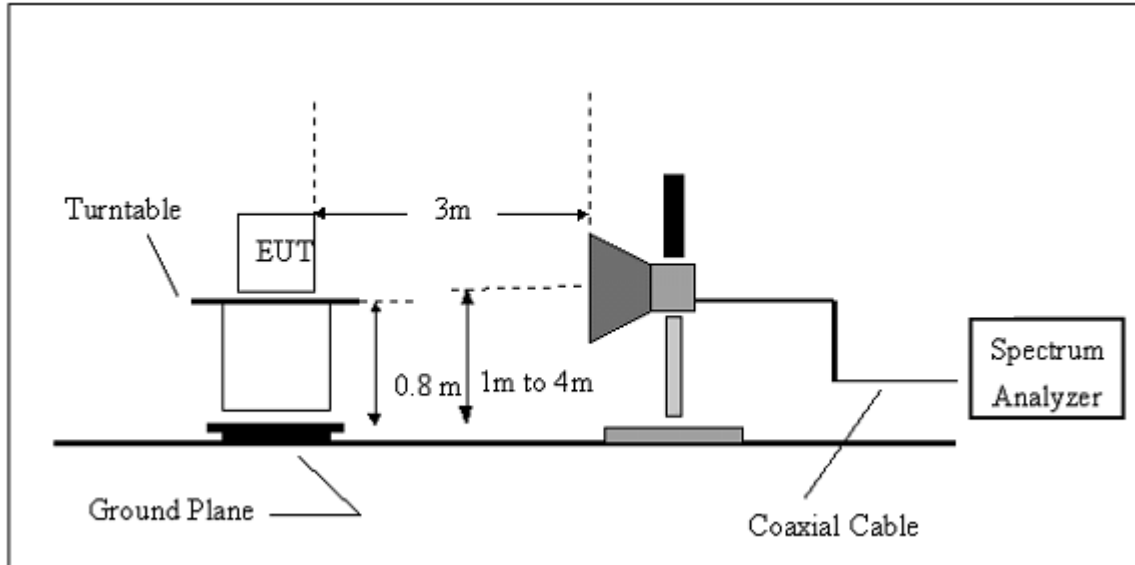
**(C) Radiated Emission Test-Up Frequency Above 1GHz****3.2.5 EUT OPERATING CONDITIONS**

The EUT tested system was configured as the statements of 2.4 Unless otherwise a special operating condition is specified in the follows during the testing.

**3.2.6 TEST RESULTS (BETWEEN 9KHZ – 30 MHZ)**

EUT:	MID	Model Name. :	MID7326CM
Temperature:	20 °C	Relative Humidity:	48%
Pressure:	1010 hPa	Test Voltage :	DC 5V From Adapter AC 120V/60Hz
Test Mode :	TX	Polarization :	--

Freq.	Reading	Limit	Margin	State
(MHz)	(dBuV/m)	(dBuV/m)	(dB)	P/F
--	--	--	--	PASS
--	--	--	--	PASS

**NOTE:**

The amplitude of spurious emissions which are attenuated by more than 20dB below the permissible value has no need to be reported.

Distance extrapolation factor =  $20 \log (\text{specific distance}/\text{test distance})(\text{dB})$ ;

Limit line = specific limits(dBuv) + distance extrapolation factor.

### 3.2.7 TEST RESULTS (BETWEEN 30MHZ – 1GHZ)

EUT :	MID	Model Name :	MID7326CM
Temperature :	20 °C	Relative Humidity :	48%
Pressure :	1010 hPa	Test Voltage :	DC 5V From Adapter AC 120V/60Hz
Test Mode :	TX	Polarization :	Horizontal

Frequency (MHz)	Meter Reading (dBµV)	Factor (dB)	Emission Level (dBµV/m)	Limits (dBµV/m)	Margin (dB)	Detector Type
172.5988	18.79	10.24	29.03	43.50	-14.47	QP
236.6447	20.36	11.26	31.62	46.00	-14.38	QP
323.3204	23.26	15.58	38.84	46.00	-7.16	QP
640.6109	14.95	23.45	38.40	46.00	-7.60	QP

Remark:  
Factor = Antenna Factor + Cable Loss – Pre-amplifier.

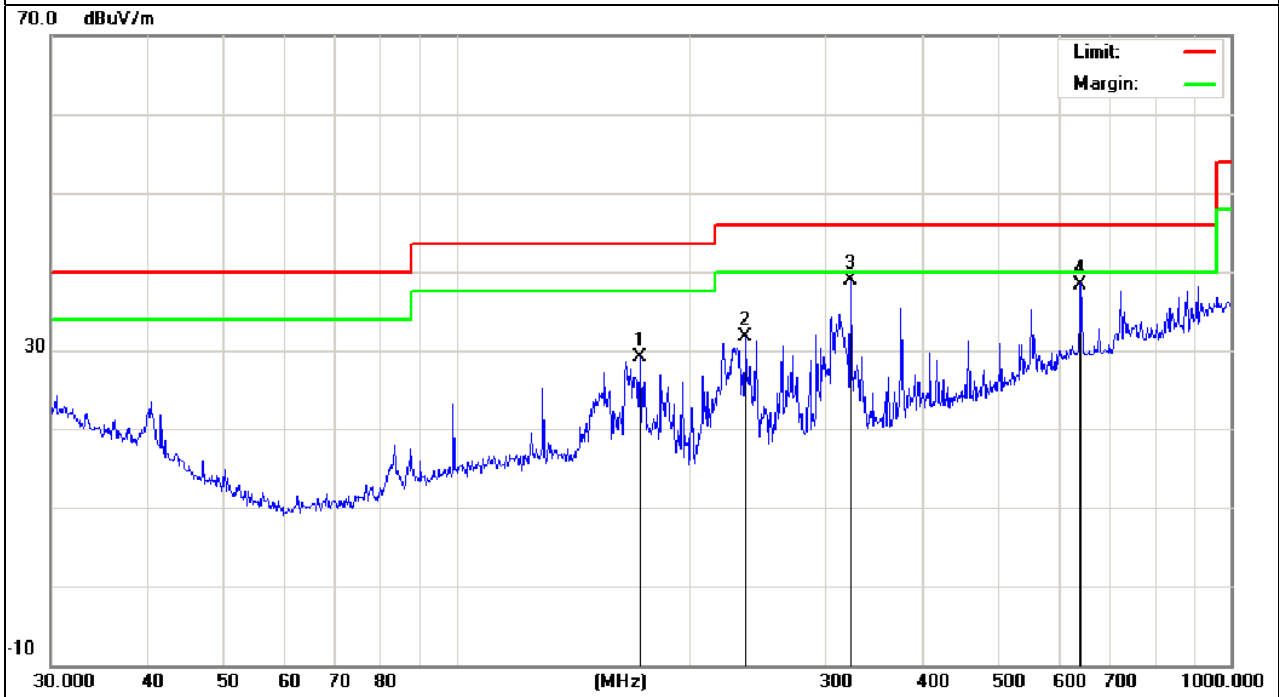

EUT :	MID	Model Name :	MID7326CM
Temperature :	20 °C	Relative Humidity :	48%
Pressure :	1010 hPa	Test Voltage :	DC 5V From Adapter AC 120V/60Hz
Test Mode :	TX	Polarization :	Vertical

Frequency (MHz)	Meter Reading (dBµV)	Factor (dB)	Emission Level (dBµV/m)	Limits (dBµV/m)	Margin (dB)	Detector Type
52.2079	16.64	7.15	23.79	40.00	-16.21	QP
125.0066	14.91	11.90	26.81	43.50	-16.69	QP
289.0021	20.39	13.89	34.28	46.00	-11.72	QP
552.8832	13.65	21.78	35.43	46.00	-10.57	QP

Remark:

Factor = Antenna Factor + Cable Loss – Pre-amplifier.

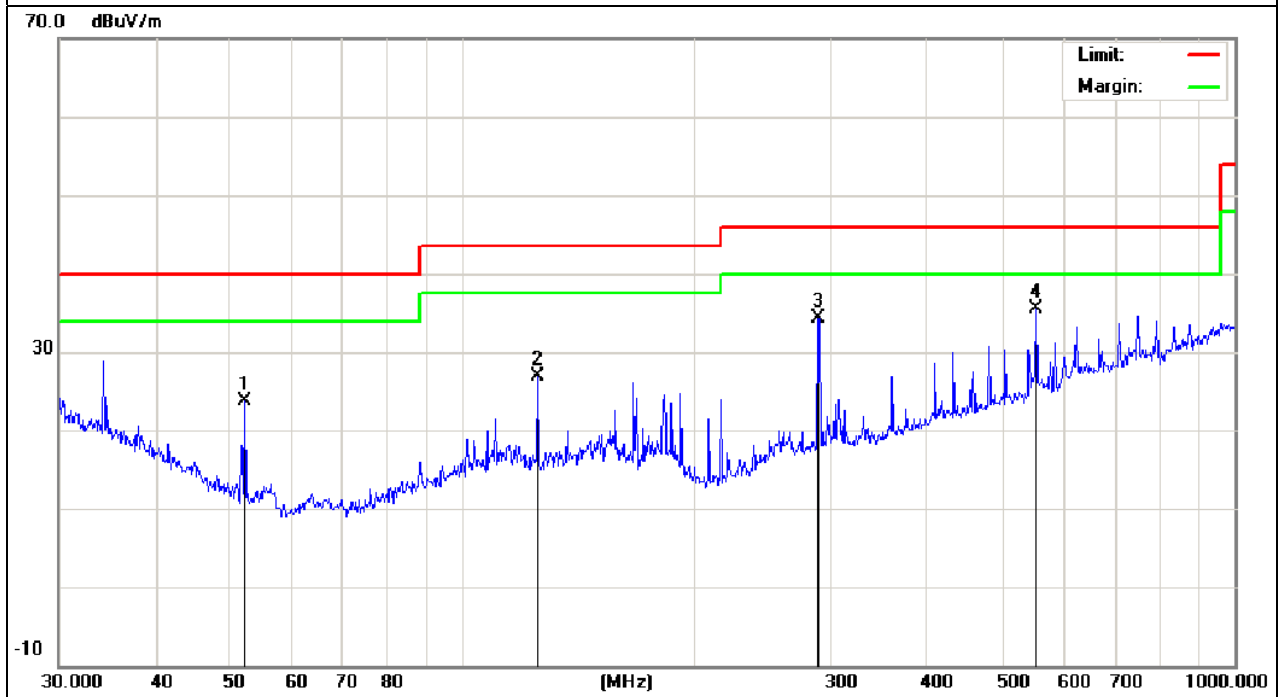

### 3.2.8 TEST RESULTS (ABOVE 1000 MHZ)

EUT :	MID	Model Name :	MID7326CM
Temperature :	20 °C	Relative Humidity :	48%
Pressure :	1010 hPa	Test Voltage :	DC 5V From Adapter AC 120V/60Hz
Test Mode :	CH1 (802.11b Mode)	Polarization :	Horizontal

Frequency (MHz)	Meter Reading (dBμV)	Factor (dB)	Emission Level (dBμV/m)	Limits (dBμV/m)	Margin (dB)	Detector Type
4824.000	66.34	-3.60	62.74	74.00	-11.26	peak
4824.000	49.13	-3.60	45.53	54.00	-8.47	AVG
7326.000	60.83	-0.82	60.01	74.00	-13.99	peak
7326.000	48.16	-0.82	47.34	54.00	-6.66	AVG

Remark:  
Factor = Antenna Factor + Cable Loss – Pre-amplifier.

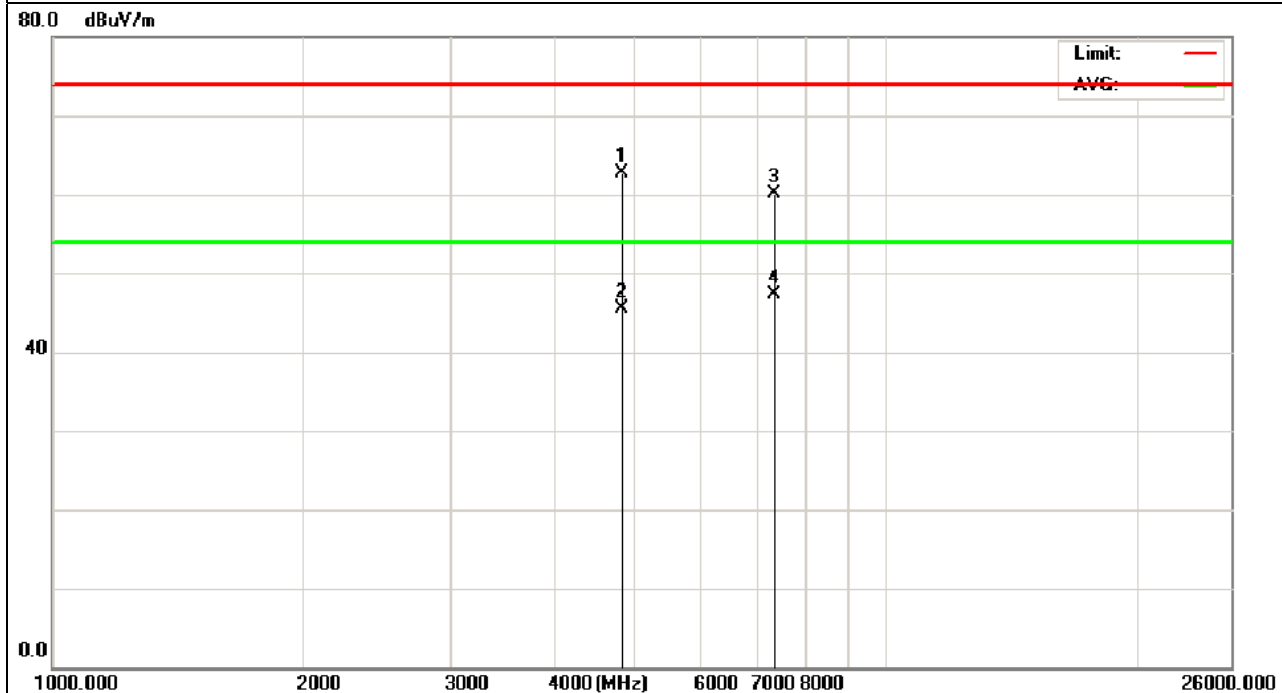



EUT :	MID	Model Name :	MID7326CM
Temperature :	20 °C	Relative Humidity :	48%
Pressure :	1010 hPa	Test Voltage :	DC 5V From Adapter AC 120V/60Hz
Test Mode :	CH1 (802.11b Mode)	Polarization :	Vertical

Frequency (MHz)	Meter Reading (dBµV)	Factor (dB)	Emission Level (dBµV/m)	Limits (dBµV/m)	Margin (dB)	Detector Type
4824.000	66.29	-3.60	62.69	74.00	-11.31	peak
4824.000	50.37	-3.60	46.77	54.00	-7.23	AVG
7326.000	61.76	-0.82	60.94	74.00	-13.06	peak
7326.000	46.13	-0.82	45.31	54.00	-8.69	AVG

Remark:

Factor = Antenna Factor + Cable Loss – Pre-amplifier.

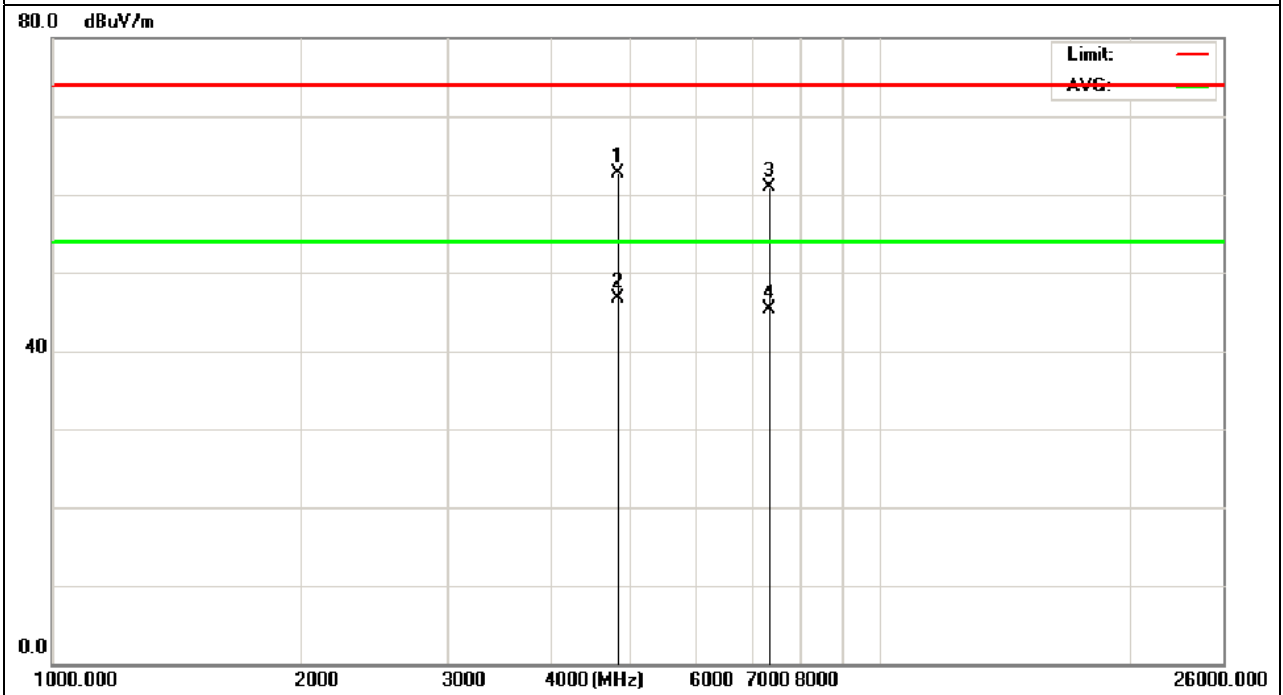

EUT :	MID	Model Name :	MID7326CM
Temperature :	20 °C	Relative Humidity :	48%
Pressure :	1010 hPa	Test Voltage :	DC 5V From Adapter AC 120V/60Hz
Test Mode :	CH6 (802.11b Mode)	Polarization :	Horizontal

Frequency (MHz)	Meter Reading (dBµV)	Factor (dB)	Emission Level (dBµV/m)	Limits (dBµV/m)	Margin (dB)	Detector Type
4874.000	66.31	-3.64	62.67	74.00	-11.33	peak
4874.000	48.72	-3.64	45.08	54.00	-8.92	AVG
7311.000	62.49	-0.80	61.69	74.00	-12.31	peak
7311.000	48.71	-0.80	47.91	54.00	-6.09	AVG

Remark:  
Factor = Antenna Factor + Cable Loss – Pre-amplifier.

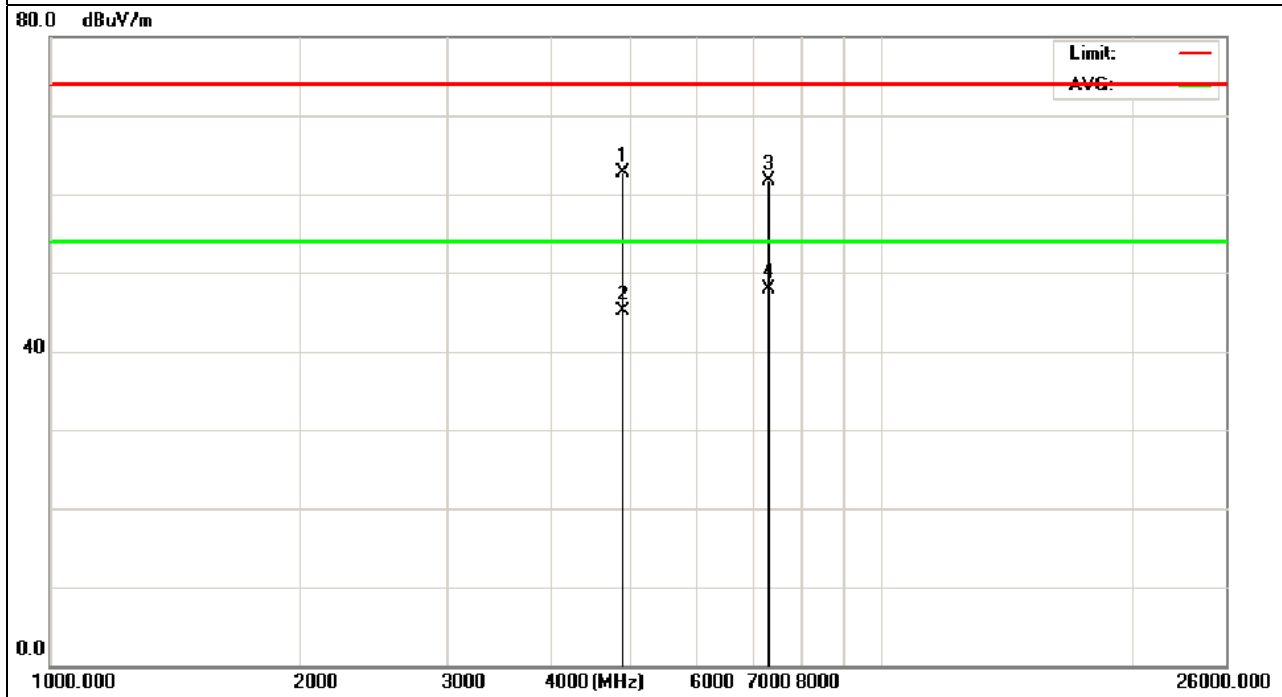

EUT :	MID	Model Name :	MID7326CM
Temperature :	20 °C	Relative Humidity :	48%
Pressure :	1010 hPa	Test Voltage :	DC 5V From Adapter AC 120V/60Hz
Test Mode :	CH6 (802.11b Mode)	Polarization :	Vertical

Frequency (MHz)	Meter Reading (dBµV)	Factor (dB)	Emission Level (dBµV/m)	Limits (dBµV/m)	Margin (dB)	Detector Type
4874.000	66.59	-3.64	62.95	74.00	-11.05	peak
4874.000	49.78	-3.64	46.14	54.00	-7.86	AVG
7311.000	61.03	-0.80	60.23	74.00	-13.77	peak
7311.000	47.06	-0.80	46.26	54.00	-7.74	AVG

Remark:  
Factor = Antenna Factor + Cable Loss – Pre-amplifier.

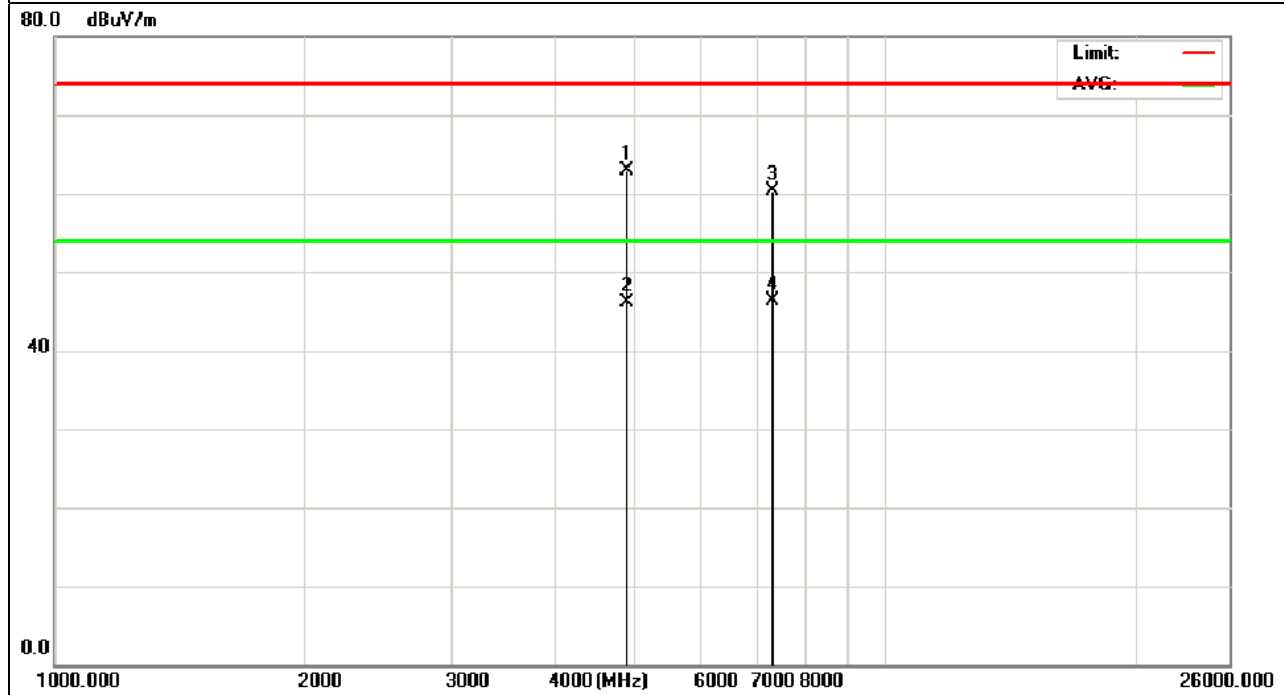

EUT :	MID	Model Name :	MID7326CM
Temperature :	20 °C	Relative Humidity :	48%
Pressure :	1010 hPa	Test Voltage :	DC 5V From Adapter AC 120V/60Hz
Test Mode :	CH11 (802.11b Mode)	Polarization :	Horizontal

Frequency (MHz)	Meter Reading (dBµV)	Factor (dB)	Emission Level (dBµV/m)	Limits (dBµV/m)	Margin (dB)	Detector Type
4924.000	68.53	-3.66	64.87	74.00	-9.13	peak
4924.000	52.61	-3.66	48.95	54.00	-5.05	AVG
7386.000	67.16	-1.03	66.13	74.00	-7.87	peak
7386.000	50.31	-1.03	49.28	54.00	-4.72	AVG

Remark:

- Factor = Antenna Factor + Cable Loss – Pre-amplifier.
- No emission detected above 18GHz

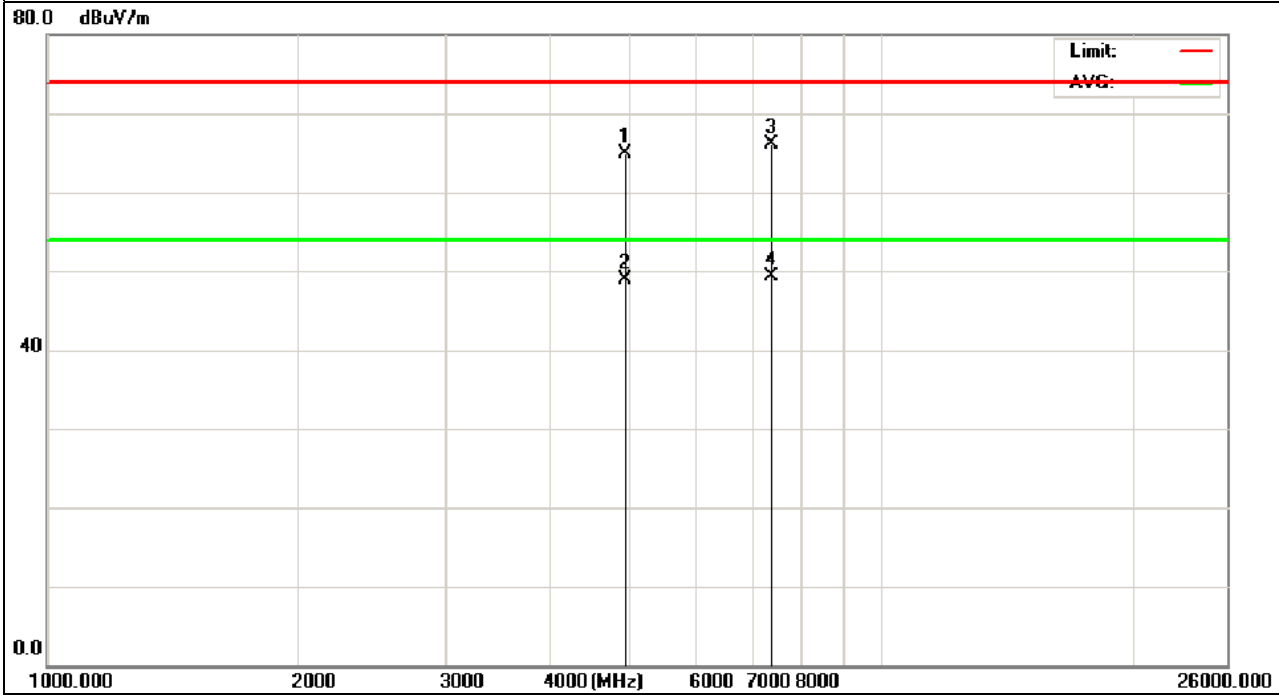

EUT :	MID	Model Name :	MID7326CM
Temperature :	20 °C	Relative Humidity :	48%
Pressure :	1010 hPa	Test Voltage :	DC 5V From Adapter AC 120V/60Hz
Test Mode :	CH11 (802.11b Mode)	Polarization :	Vertical

Frequency (MHz)	Meter Reading (dBµV)	Factor (dB)	Emission Level (dBµV/m)	Limits (dBµV/m)	Margin (dB)	Detector Type
4924.000	66.71	-3.66	63.05	74.00	-10.95	peak
4924.000	50.16	-3.66	46.50	54.00	-7.50	AVG
7386.000	63.04	-1.03	62.01	74.00	-11.99	peak
7386.000	48.16	-1.03	47.13	54.00	-6.87	AVG

Remark:  
Factor = Antenna Factor + Cable Loss – Pre-amplifier.

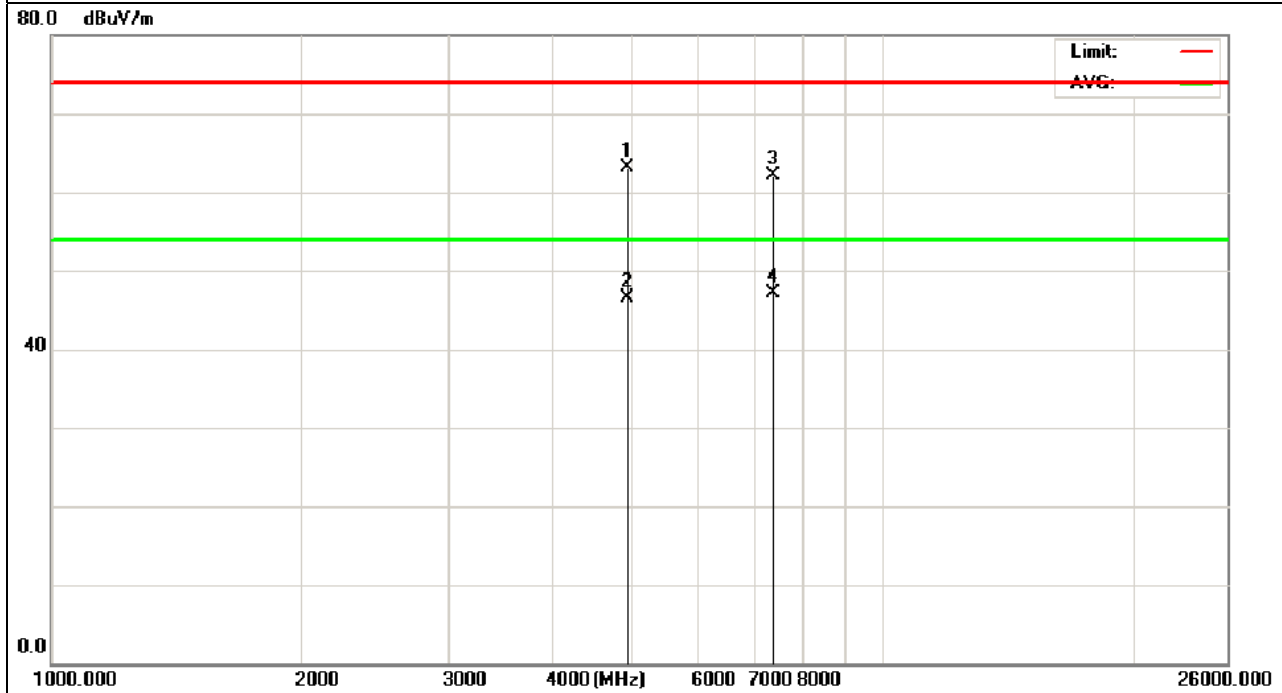

EUT :	MID	Model Name :	MID7326CM
Temperature :	20 °C	Relative Humidity :	48%
Pressure :	1010 hPa	Test Voltage :	DC 5V From Adapter AC 120V/60Hz
Test Mode :	CH1 (802.11g Mode)	Polarization :	Horizontal

Frequency (MHz)	Meter Reading (dBμV)	Factor (dB)	Emission Level (dBμV/m)	Limits (dBμV/m)	Margin (dB)	Detector Type
4824.000	65.23	-3.60	61.63	74.00	-12.37	peak
4824.000	52.06	-3.60	48.46	54.00	-5.54	AVG
7326.000	63.15	-0.82	62.33	74.00	-11.67	peak
7326.000	49.41	-0.82	48.59	54.00	-5.41	AVG

Remark:  
Factor = Antenna Factor + Cable Loss – Pre-amplifier.

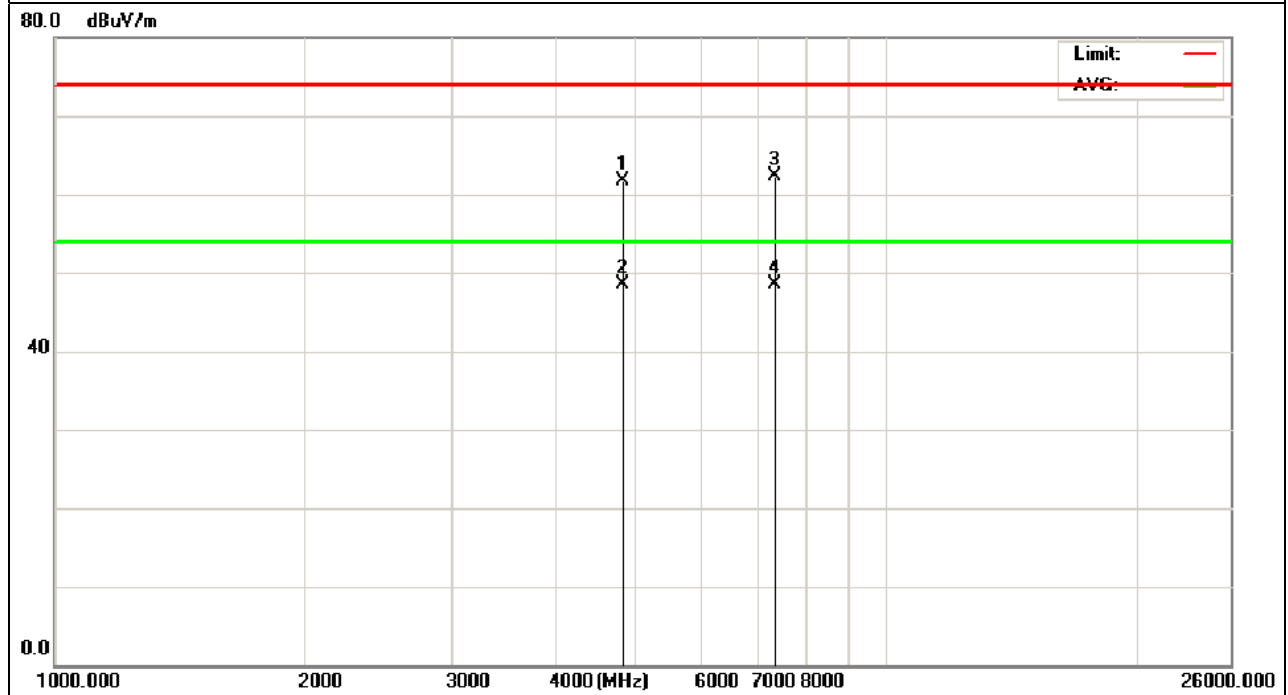

EUT :	MID	Model Name :	MID7326CM
Temperature :	20 °C	Relative Humidity :	48%
Pressure :	1010 hPa	Test Voltage :	DC 5V From Adapter AC 120V/60Hz
Test Mode :	CH1 (802.11g Mode)	Polarization :	Vertical

Frequency (MHz)	Meter Reading (dBμV)	Factor (dB)	Emission Level (dBμV/m)	Limits (dBμV/m)	Margin (dB)	Detector Type
4824.000	64.82	-3.60	61.22	74.00	-12.78	peak
4824.000	49.03	-3.60	45.43	54.00	-8.57	AVG
7326.000	60.76	-0.82	59.94	74.00	-14.06	peak
7326.000	47.01	-0.82	46.19	54.00	-7.81	AVG

Remark:  
Factor = Antenna Factor + Cable Loss – Pre-amplifier.

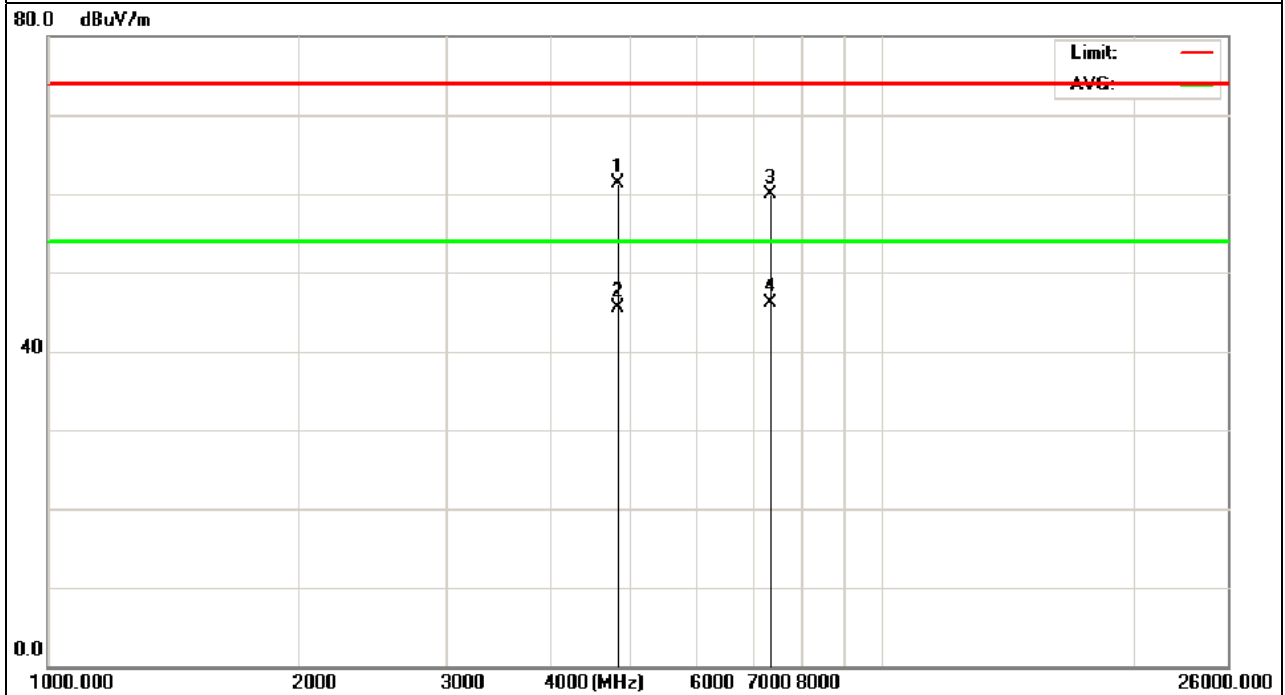

EUT :	MID	Model Name :	MID7326CM
Temperature :	20 °C	Relative Humidity :	48%
Pressure :	1010 hPa	Test Voltage :	DC 5V From Adapter AC 120V/60Hz
Test Mode :	CH6 (802.11g Mode)	Polarization :	Horizontal

Frequency (MHz)	Meter Reading (dBµV)	Factor (dB)	Emission Level (dBµV/m)	Limits (dBµV/m)	Margin (dB)	Detector Type
4874.000	63.59	-3.64	59.95	74.00	-14.05	peak
4874.000	48.34	-3.64	44.70	54.00	-9.30	AVG
7311.000	57.46	-0.80	56.66	74.00	-17.34	peak
7311.000	45.16	-0.80	44.36	54.00	-9.64	AVG

Remark:  
Factor = Antenna Factor + Cable Loss – Pre-amplifier.

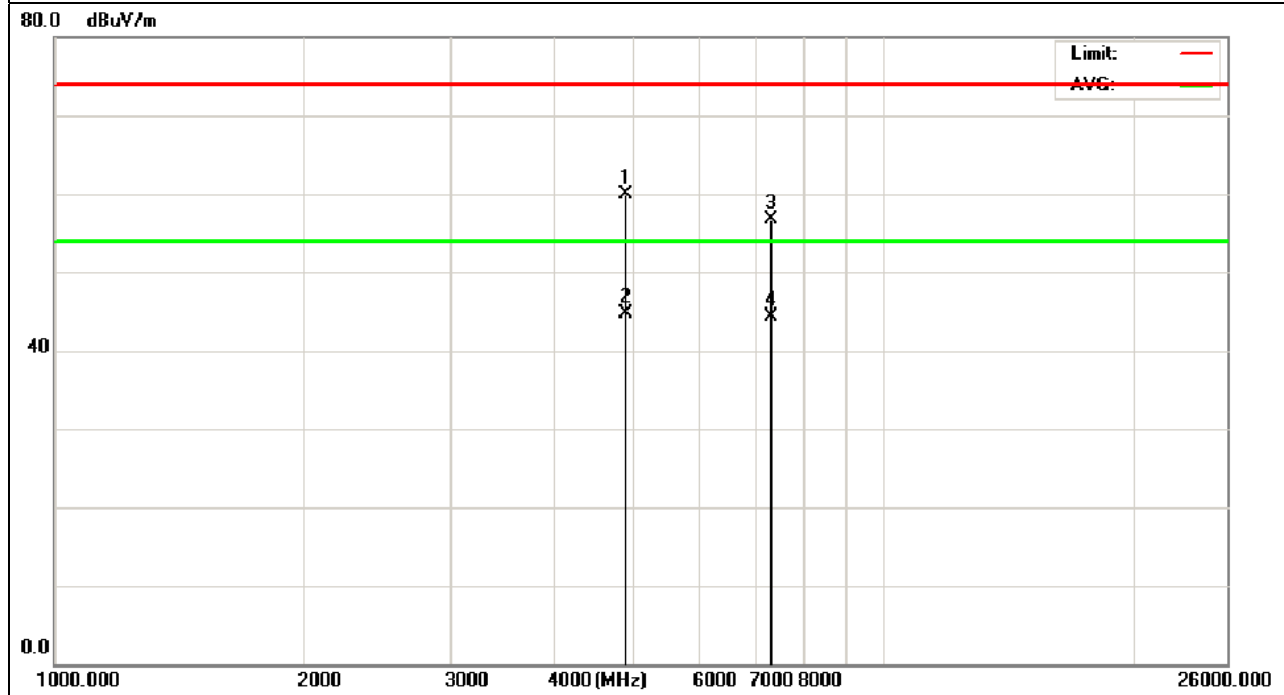



EUT :	MID	Model Name :	MID7326CM
Temperature :	20 °C	Relative Humidity :	48%
Pressure :	1010 hPa	Test Voltage :	DC 5V From Adapter AC 120V/60Hz
Test Mode :	CH6 (802.11g Mode)	Polarization :	Vertical

Frequency (MHz)	Meter Reading (dBμV)	Factor (dB)	Emission Level (dBμV/m)	Limits (dBμV/m)	Margin (dB)	Detector Type
4874.000	64.18	-3.64	60.54	74.00	-13.46	peak
4874.000	47.37	-3.64	43.73	54.00	-10.27	AVG
7311.000	57.13	-0.80	56.33	74.00	-17.67	peak
7311.000	45.08	-0.80	44.28	54.00	-9.72	AVG

Remark:  
Factor = Antenna Factor + Cable Loss – Pre-amplifier.

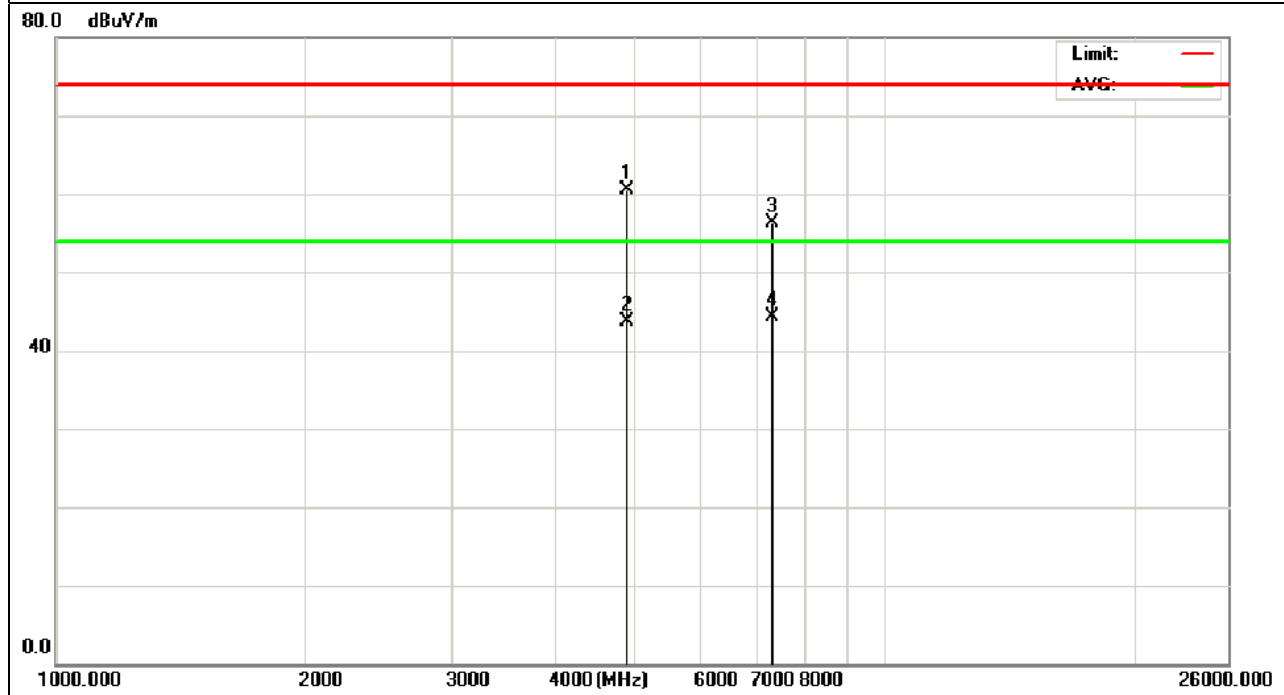

EUT :	MID	Model Name :	MID7326CM
Temperature :	20 °C	Relative Humidity :	48%
Pressure :	1010 hPa	Test Voltage :	DC 5V From Adapter AC 120V/60Hz
Test Mode :	CH11 (802.11g Mode)	Polarization :	Horizontal

Frequency (MHz)	Meter Reading (dBµV)	Factor (dB)	Emission Level (dBµV/m)	Limits (dBµV/m)	Margin (dB)	Detector Type
4924.000	68.54	-3.66	64.88	74.00	-9.12	peak
4924.000	54.73	-3.66	51.07	54.00	-2.93	AVG
7386.000	64.57	-1.03	63.54	74.00	-10.46	peak
7386.000	48.61	-1.03	47.58	54.00	-6.42	AVG

Remark:  
Factor = Antenna Factor + Cable Loss – Pre-amplifier.

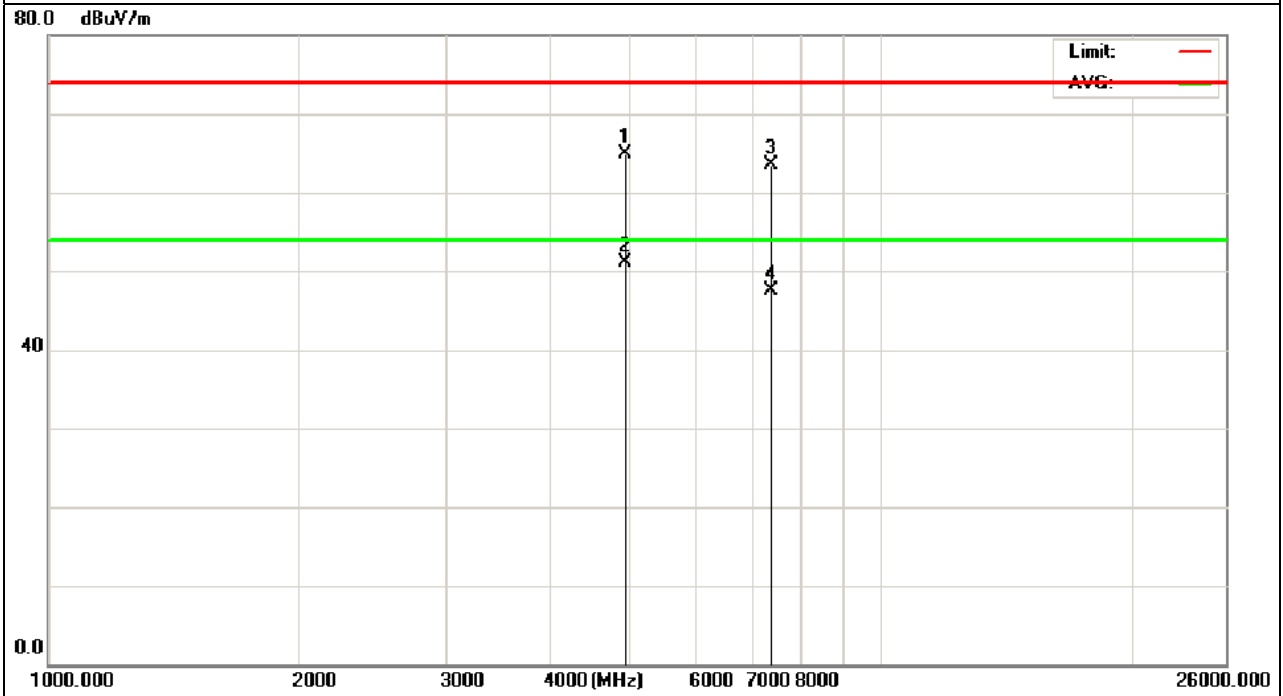

EUT :	MID	Model Name :	MID7326CM
Temperature :	20 °C	Relative Humidity :	48%
Pressure :	1010 hPa	Test Voltage :	DC 5V From Adapter AC 120V/60Hz
Test Mode :	CH11(802.11g Mode)	Polarization :	Vertical

Frequency (MHz)	Meter Reading (dBµV)	Factor (dB)	Emission Level (dBµV/m)	Limits (dBµV/m)	Margin (dB)	Detector Type
4924.000	63.35	-3.66	59.69	74.00	-14.31	peak
4924.000	47.26	-3.66	43.60	54.00	-10.40	AVG
7386.000	54.27	-1.03	53.24	74.00	-20.76	peak
7386.000	48.13	-1.03	47.10	54.00	-6.90	AVG

Remark:  
Factor = Antenna Factor + Cable Loss – Pre-amplifier.

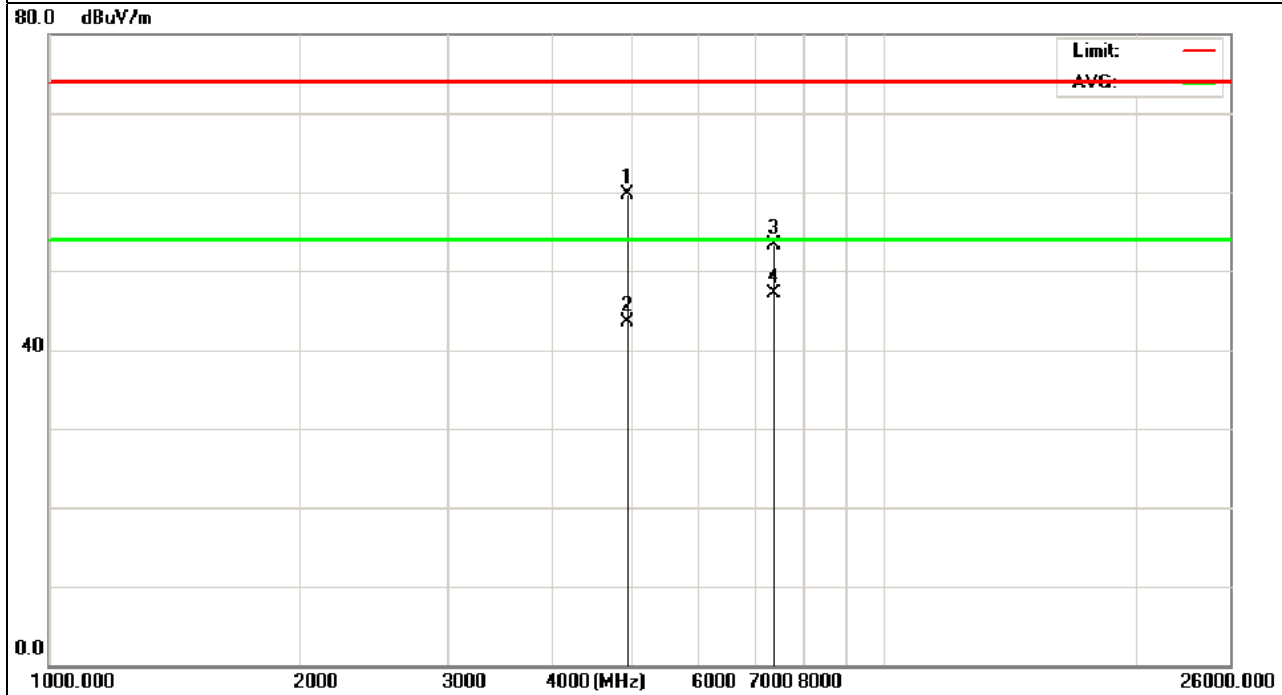

EUT :	MID	Model Name :	MID7326CM
Temperature :	20 °C	Relative Humidity :	48%
Pressure :	1010 hPa	Test Voltage :	DC 5V From Adapter AC 120V/60Hz
Test Mode :	CH1 (802.11n/20M Mode)	Polarization :	Horizontal

Frequency (MHz)	Meter Reading (dBμV)	Factor (dB)	Emission Level (dBμV/m)	Limits (dBμV/m)	Margin (dB)	Detector Type
4824.000	64.19	-3.60	60.59	74.00	-13.41	peak
4824.000	49.31	-3.60	45.71	54.00	-8.29	AVG
7326.000	59.26	-0.82	58.44	74.00	-15.56	peak
7326.000	48.06	-0.82	47.24	54.00	-6.76	AVG

Remark:  
Factor = Antenna Factor + Cable Loss – Pre-amplifier.

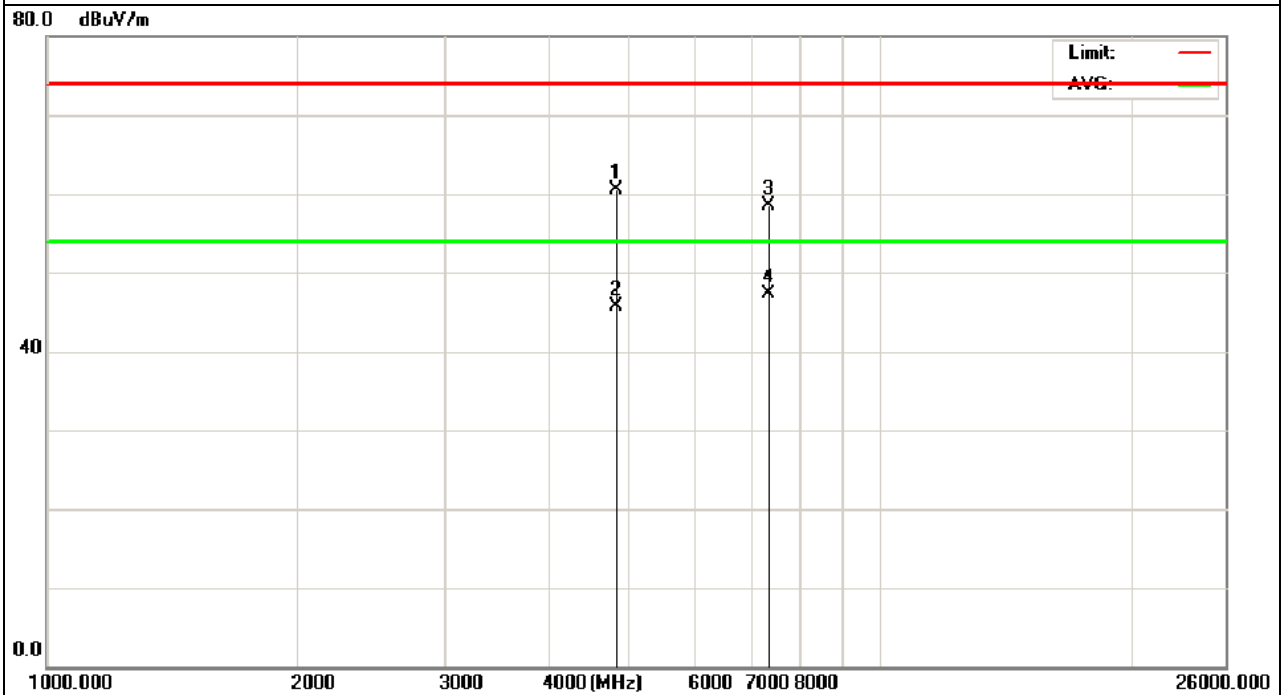

EUT :	MID	Model Name :	MID7326CM
Temperature :	20 °C	Relative Humidity :	48%
Pressure :	1010 hPa	Test Voltage :	DC 5V From Adapter AC 120V/60Hz
Test Mode :	CH1 (802.11n/20M Mode)	Polarization :	Vertical

Frequency (MHz)	Meter Reading (dBµV)	Factor (dB)	Emission Level (dBµV/m)	Limits (dBµV/m)	Margin (dB)	Detector Type
4824.000	65.26	-3.60	61.66	74.00	-12.34	peak
4824.000	46.12	-3.60	42.52	54.00	-11.48	AVG
7326.000	54.59	-0.82	53.77	74.00	-20.23	peak
7326.000	44.28	-0.82	43.46	54.00	-10.54	AVG

Remark:  
Factor = Antenna Factor + Cable Loss – Pre-amplifier.

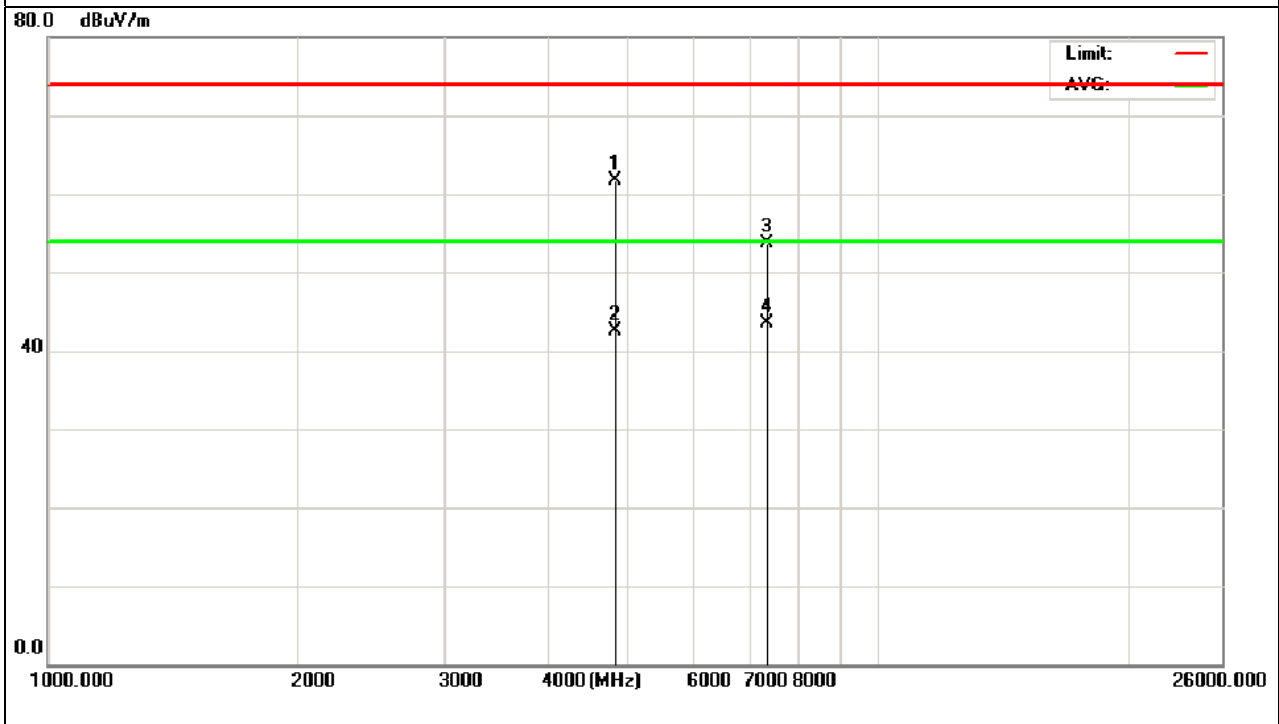

EUT :	MID	Model Name :	MID7326CM
Temperature :	20 °C	Relative Humidity :	48%
Pressure :	1010 hPa	Test Voltage :	DC 5V From Adapter AC 120V/60Hz
Test Mode :	CH6 (802.11n/20M Mode)	Polarization :	Horizontal

Frequency (MHz)	Meter Reading (dBμV)	Factor (dB)	Emission Level (dBμV/m)	Limits (dBμV/m)	Margin (dB)	Detector Type
4874.000	66.18	-3.64	62.54	74.00	-11.46	peak
4874.000	49.26	-3.64	45.62	54.00	-8.38	AVG
7311.000	60.32	-0.80	59.52	74.00	-14.48	peak
7311.000	48.56	-0.80	47.76	54.00	-6.24	AVG

Remark:  
Factor = Antenna Factor + Cable Loss – Pre-amplifier.

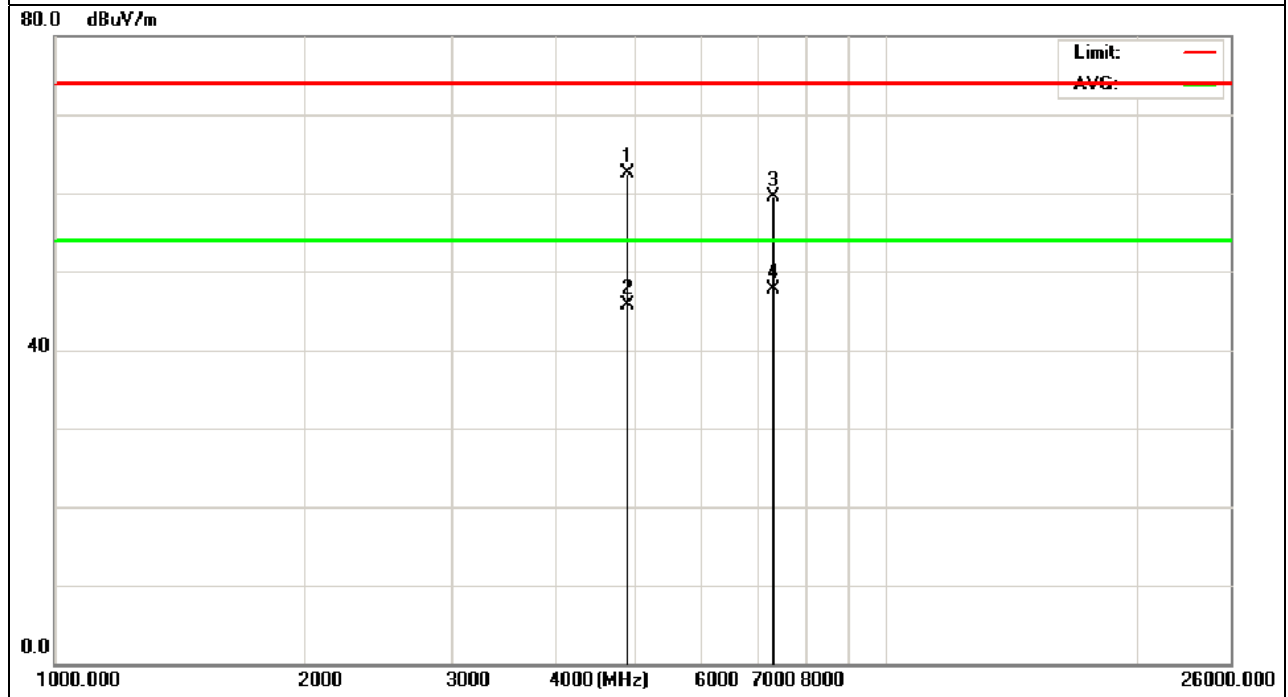

EUT :	MID	Model Name :	MID7326CM
Temperature :	20 °C	Relative Humidity :	48%
Pressure :	1010 hPa	Test Voltage :	DC 5V From Adapter AC 120V/60Hz
Test Mode :	CH6 (802.11n/20M Mode)	Polarization :	Vertical

Frequency (MHz)	Meter Reading (dBµV)	Factor (dB)	Emission Level (dBµV/m)	Limits (dBµV/m)	Margin (dB)	Detector Type
4874.000	64.30	-3.64	60.66	74.00	-13.34	peak
4874.000	49.76	-3.64	46.12	54.00	-7.88	AVG
7311.000	61.35	-0.80	60.55	74.00	-13.45	peak
7311.000	48.75	-0.80	47.95	54.00	-6.05	AVG

Remark:

Factor = Antenna Factor + Cable Loss – Pre-amplifier.

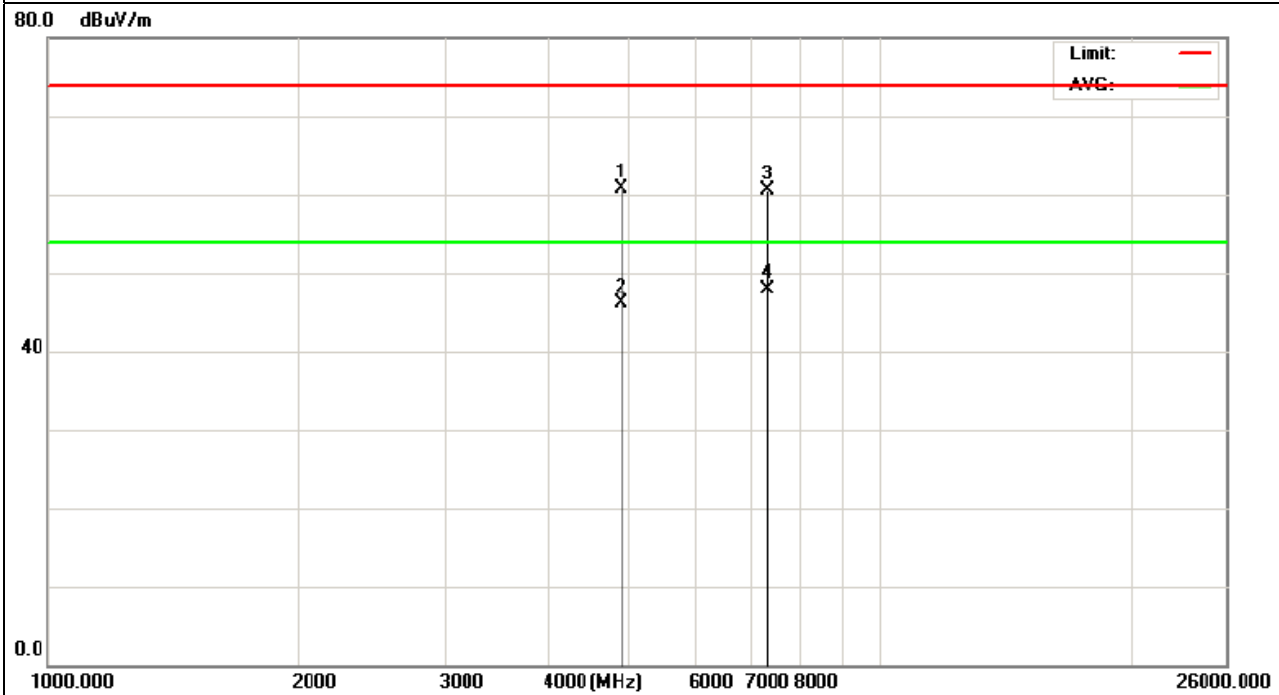

EUT :	MID	Model Name :	MID7326CM
Temperature :	20 °C	Relative Humidity :	48%
Pressure :	1010 hPa	Test Voltage :	DC 5V From Adapter AC 120V/60Hz
Test Mode :	CH11 (802.11n/20M Mode)	Polarization :	Horizontal

Frequency (MHz)	Meter Reading (dBµV)	Factor (dB)	Emission Level (dBµV/m)	Limits (dBµV/m)	Margin (dB)	Detector Type
4924.000	64.23	-3.66	60.57	74.00	-13.43	peak
4924.000	50.22	-3.66	46.56	54.00	-7.44	AVG
7386.000	60.31	-1.03	59.28	74.00	-14.72	peak
7386.000	46.07	-1.03	45.04	54.00	-8.96	AVG

**Remark:**

- 3. Factor = Antenna Factor + Cable Loss – Pre-amplifier.
- 4. No emission detected above 18GHz

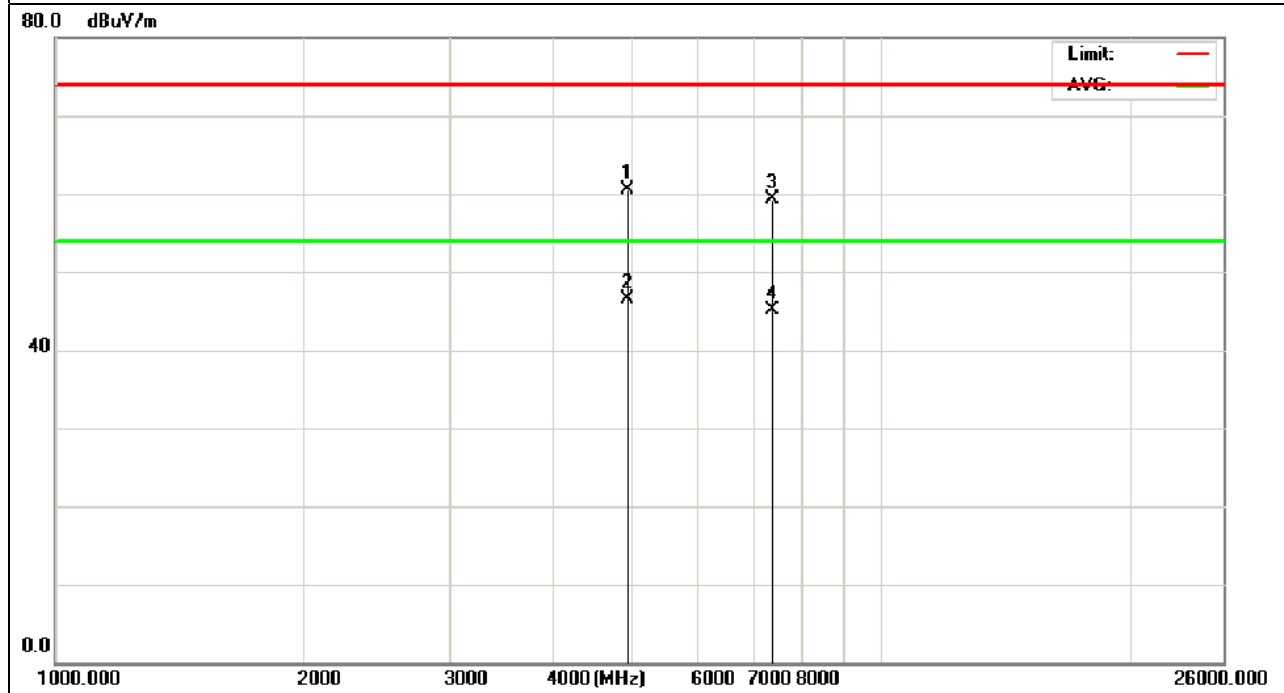



EUT :	MID	Model Name :	MID7326CM
Temperature :	20 °C	Relative Humidity :	48%
Pressure :	1010 hPa	Test Voltage :	DC 5V From Adapter AC 120V/60Hz
Test Mode :	CH11 (802.11n/20M Mode)	Polarization :	Vertical

Frequency (MHz)	Meter Reading (dBμV)	Factor (dB)	Emission Level (dBμV/m)	Limits (dBμV/m)	Margin (dB)	Detector Type
4924.000	66.03	-3.66	62.37	74.00	-11.63	peak
4924.000	51.59	-3.66	47.93	54.00	-6.07	AVG
7386.000	62.36	-1.03	61.33	74.00	-12.67	peak
7386.000	51.73	-1.03	50.70	54.00	-3.30	AVG

Remark:  
Factor = Antenna Factor + Cable Loss – Pre-amplifier.

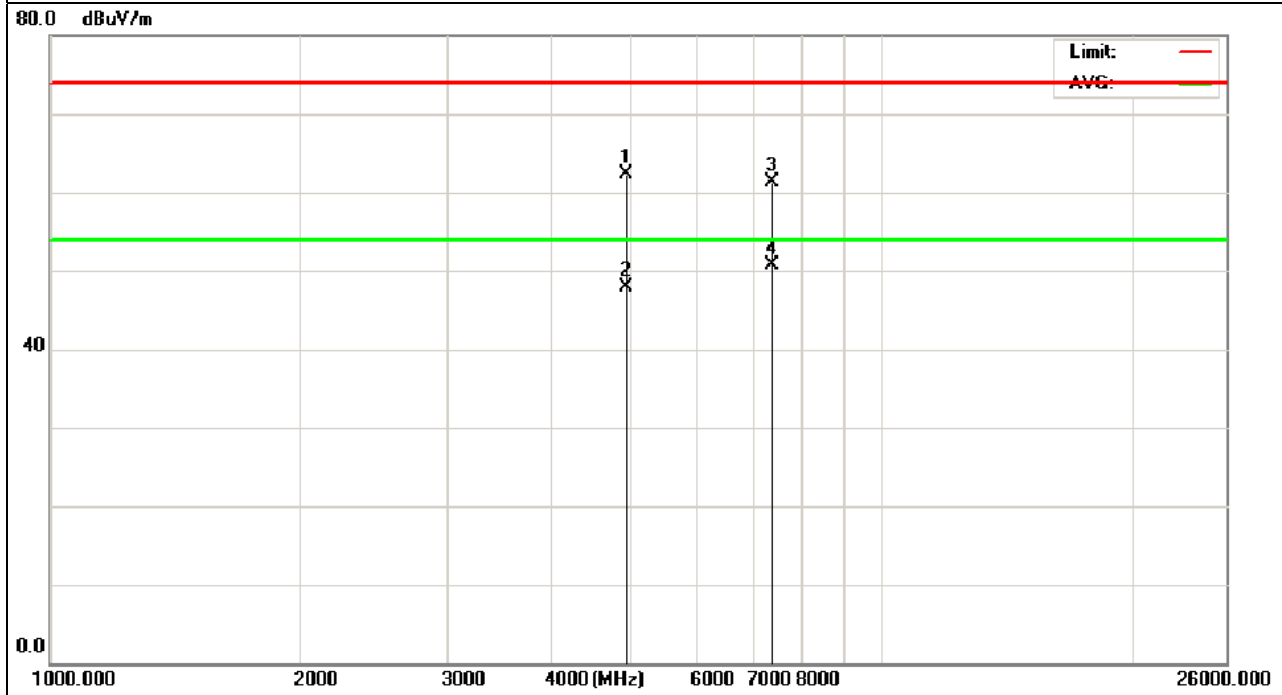

EUT :	MID	Model Name :	MID7326CM
Temperature :	20 °C	Relative Humidity :	48%
Pressure :	1010 hPa	Test Voltage :	DC 5V From Adapter AC 120V/60Hz
Test Mode :	CH3 (802.11n/40M Mode)	Polarization :	Horizontal

Frequency (MHz)	Meter Reading (dBμV)	Factor (dB)	Emission Level (dBμV/m)	Limits (dBμV/m)	Margin (dB)	Detector Type
4844.000	63.43	-3.54	59.89	74.00	-14.11	peak
4844.000	49.26	-3.54	45.72	54.00	-8.28	AVG
7266.000	60.00	-0.97	59.03	74.00	-14.97	peak
7266.000	47.03	-0.97	46.06	54.00	-7.94	AVG

Remark:  
Factor = Antenna Factor + Cable Loss – Pre-amplifier.

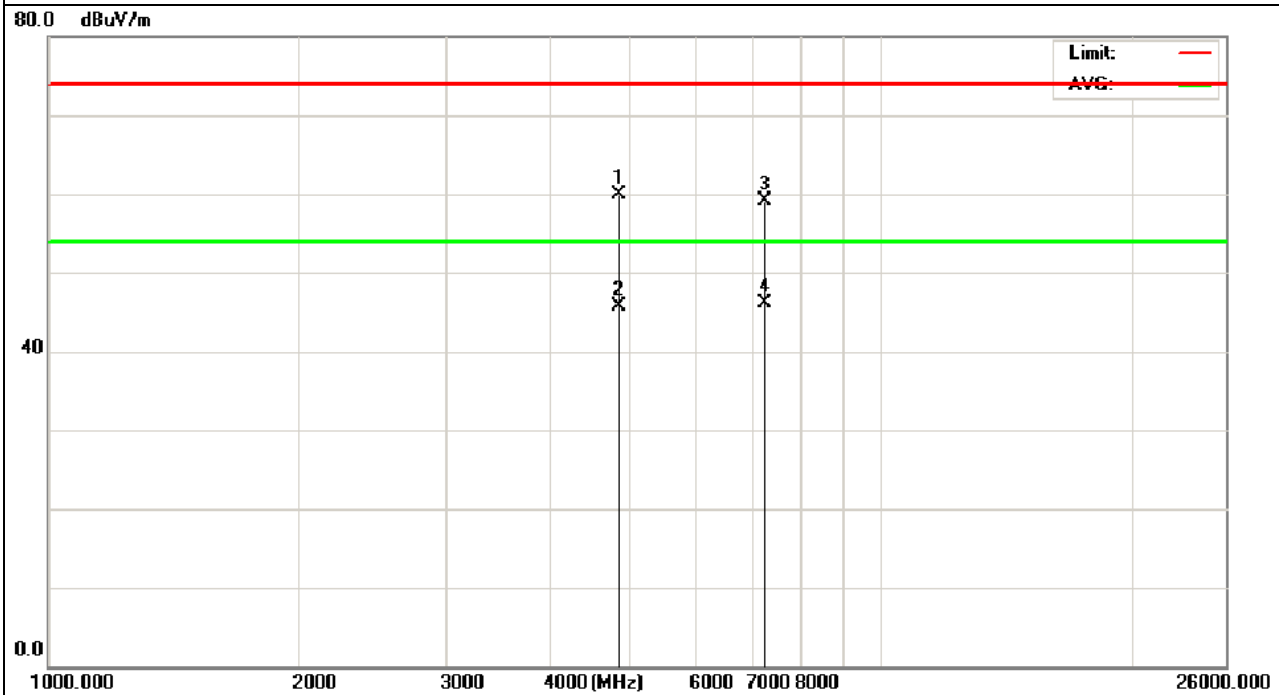

EUT :	MID	Model Name :	MID7326CM
Temperature :	20 °C	Relative Humidity :	48%
Pressure :	1010 hPa	Test Voltage :	DC 5V From Adapter AC 120V/60Hz
Test Mode :	CH3 (802.11n/40M Mode)	Polarization :	Vertical

Frequency (MHz)	Meter Reading (dBµV)	Factor (dB)	Emission Level (dBµV/m)	Limits (dBµV/m)	Margin (dB)	Detector Type
4844.000	63.53	-3.54	59.99	74.00	-14.01	peak
4844.000	49.62	-3.54	46.08	54.00	-7.92	AVG
7266.000	60.30	-0.97	59.33	74.00	-14.67	peak
7266.000	48.31	-0.97	47.34	54.00	-6.66	AVG

Remark:

Factor = Antenna Factor + Cable Loss – Pre-amplifier.

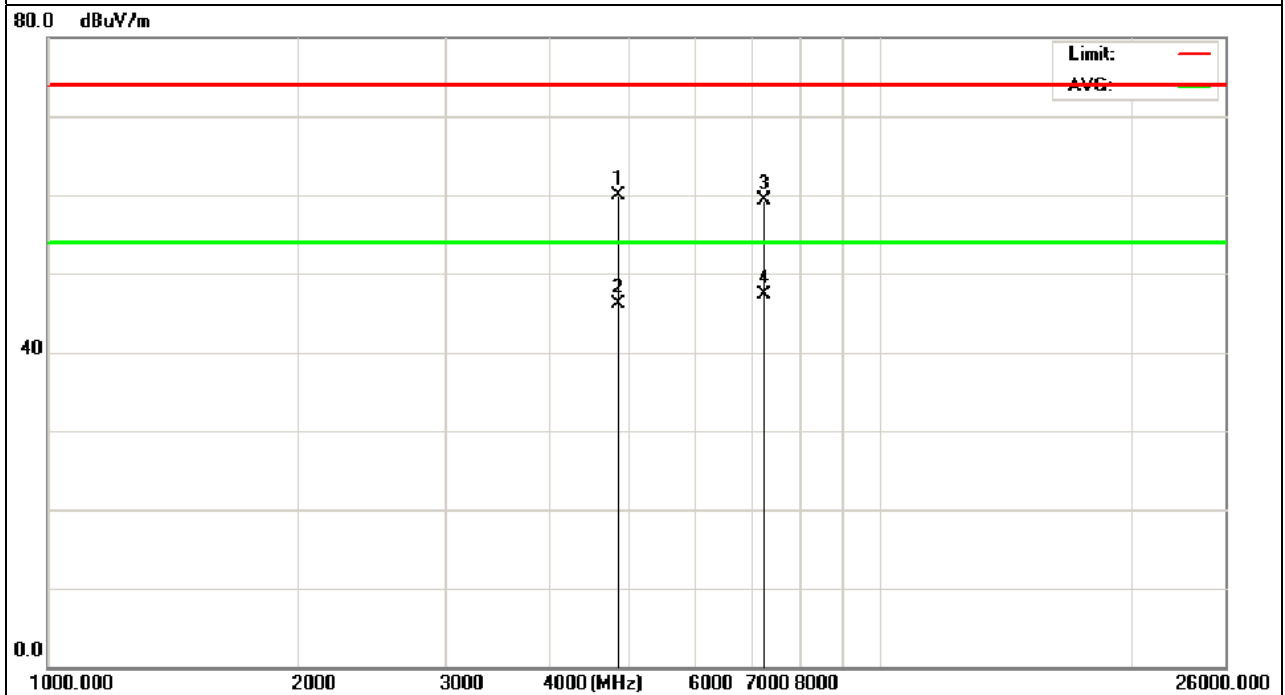

EUT :	MID	Model Name :	MID7326CM
Temperature :	20 °C	Relative Humidity :	48%
Pressure :	1010 hPa	Test Voltage :	DC 5V From Adapter AC 120V/60Hz
Test Mode :	CH6 (802.11n/40M Mode)	Polarization :	Horizontal

Frequency (MHz)	Meter Reading (dBμV)	Factor (dB)	Emission Level (dBμV/m)	Limits (dBμV/m)	Margin (dB)	Detector Type
4874.000	61.62	-3.64	57.98	74.00	-16.02	peak
4874.000	53.62	-3.68	49.98	54.00	-4.02	AVG
7311.000	59.26	-0.80	58.46	74.00	-15.54	peak
7311.000	46.08	-0.80	45.28	54.00	-8.72	AVG

Remark:  
Factor = Antenna Factor + Cable Loss – Pre-amplifier.

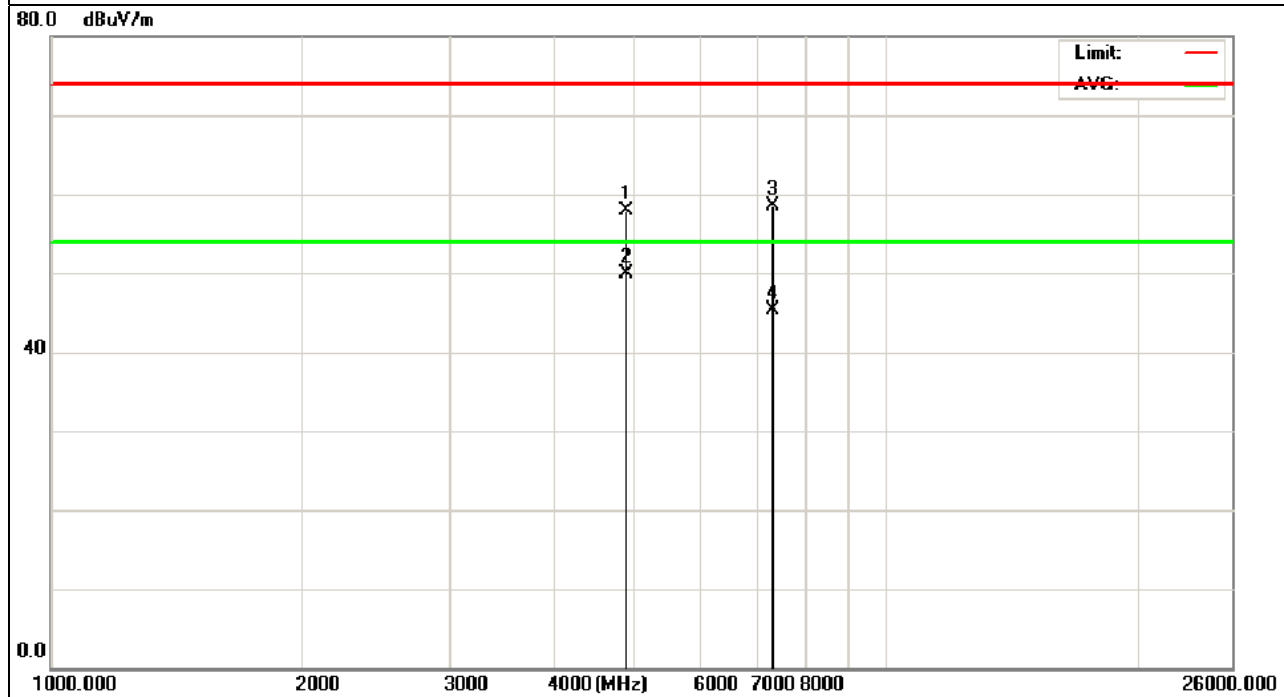

EUT :	MID	Model Name :	MID7326CM
Temperature :	20 °C	Relative Humidity :	48%
Pressure :	1010 hPa	Test Voltage :	DC 5V From Adapter AC 120V/60Hz
Test Mode :	CH6 (802.11n/40M Mode)	Polarization :	Vertical

Frequency (MHz)	Meter Reading (dBµV)	Factor (dB)	Emission Level (dBµV/m)	Limits (dBµV/m)	Margin (dB)	Detector Type
4874.000	61.26	-3.64	57.62	74.00	-16.38	peak
4874.000	53.62	-3.68	49.98	54.00	-4.02	AVG
7311.000	56.13	-0.80	55.33	74.00	-18.67	peak
7311.000	47.28	-0.80	46.48	54.00	-7.52	AVG

Remark:  
Factor = Antenna Factor + Cable Loss – Pre-amplifier.

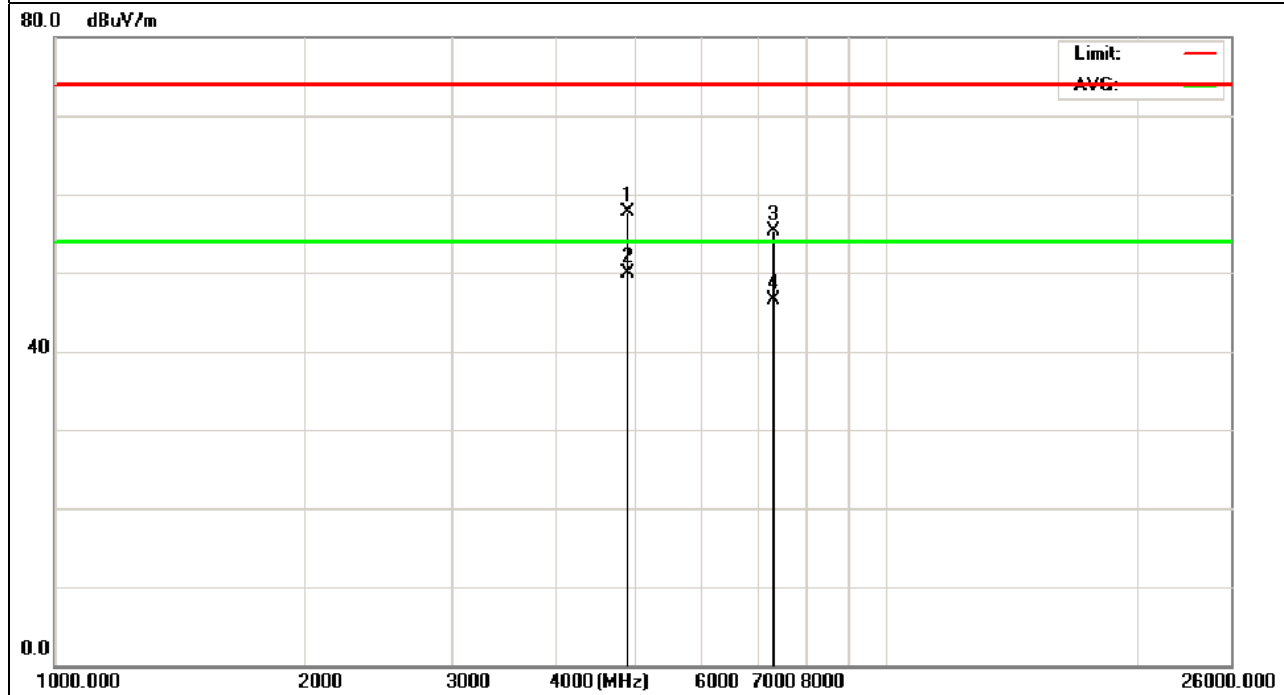

EUT :	MID	Model Name :	MID7326CM
Temperature :	20 °C	Relative Humidity :	48%
Pressure :	1010 hPa	Test Voltage :	DC 5V From Adapter AC 120V/60Hz
Test Mode :	CH9 (802.11n/40M Mode)	Polarization :	Horizontal

Frequency (MHz)	Meter Reading (dBµV)	Factor (dB)	Emission Level (dBµV/m)	Limits (dBµV/m)	Margin (dB)	Detector Type
4904.000	65.27	-3.75	61.52	74.00	-12.48	peak
4904.000	49.31	-3.75	45.56	54.00	-8.44	AVG
7356.000	61.26	-0.86	60.40	74.00	-13.60	peak
7356.000	48.03	-0.86	47.17	54.00	-6.83	AVG

**Remark:**

- 5. Factor = Antenna Factor + Cable Loss – Pre-amplifier.
- 6. No emission detected above 18GHz

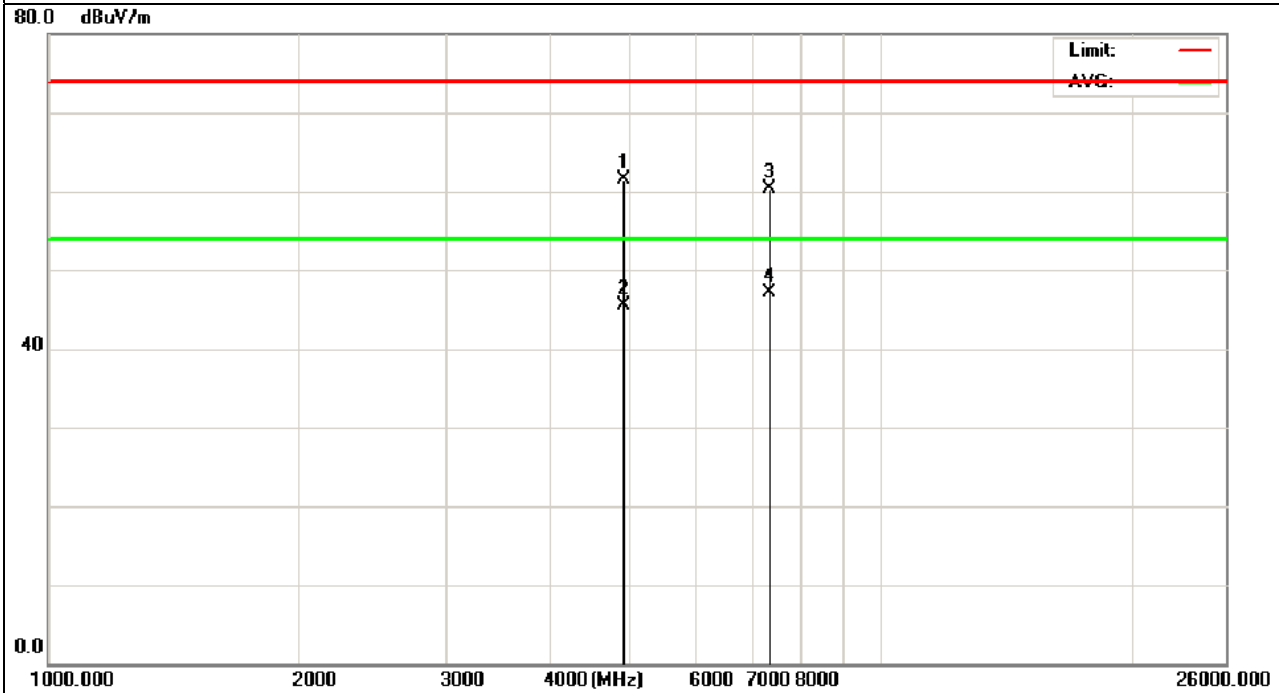

EUT :	MID	Model Name :	MID7326CM
Temperature :	20 °C	Relative Humidity :	48%
Pressure :	1010 hPa	Test Voltage :	DC 5V From Adapter AC 120V/60Hz
Test Mode :	CH9 (802.11n/40M Mode)	Polarization :	Vertical

Frequency (MHz)	Meter Reading (dBμV)	Factor (dB)	Emission Level (dBμV/m)	Limits (dBμV/m)	Margin (dB)	Detector Type
4904.000	67.06	-3.75	63.31	74.00	-10.69	peak
4904.000	53.06	-3.75	49.31	54.00	-4.69	AVG
7356.000	61.72	-0.86	60.86	74.00	-13.14	peak
7356.000	48.93	-0.86	48.07	54.00	-5.93	AVG

Remark:  
Factor = Antenna Factor + Cable Loss – Pre-amplifier.

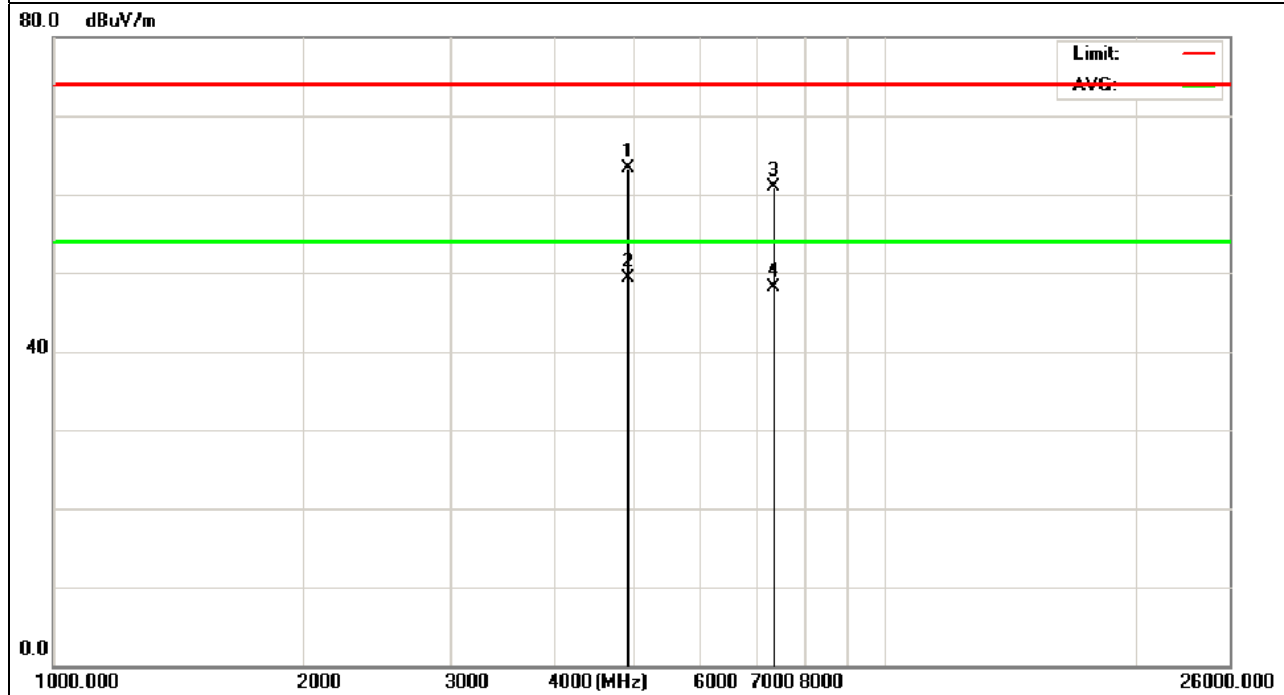

**Band Edge Emission:**

EUT :	MID	Model Name :	MID7326CM
Temperature :	20 °C	Relative Humidity :	48%
Pressure :	1010 hPa	Test Voltage :	DC 5V From Adapter AC 120V/60Hz
Test Mode :	CH1(802.11b Mode)	Polarization :	Horizontal

Frequency (MHz)	Meter Reading (dBμV)	Factor (dB)	Emission Level (dBμV/m)	Limits (dBμV/m)	Margin (dB)	Detector Type
2397.03	82.75	-17.48	65.27	74	-8.73	peak
2397.03	63.17	-17.48	45.69	54	-8.31	AVG

**Remark:**

- Factor = Antenna Factor + Cable Loss – Pre-amplifier.
- Set the Lowest and Highest Transmitting Channel, observed the outside band of 2400MHz to 2438.5MHz, then mark the higher-level emission for comparing with the FCC rules.

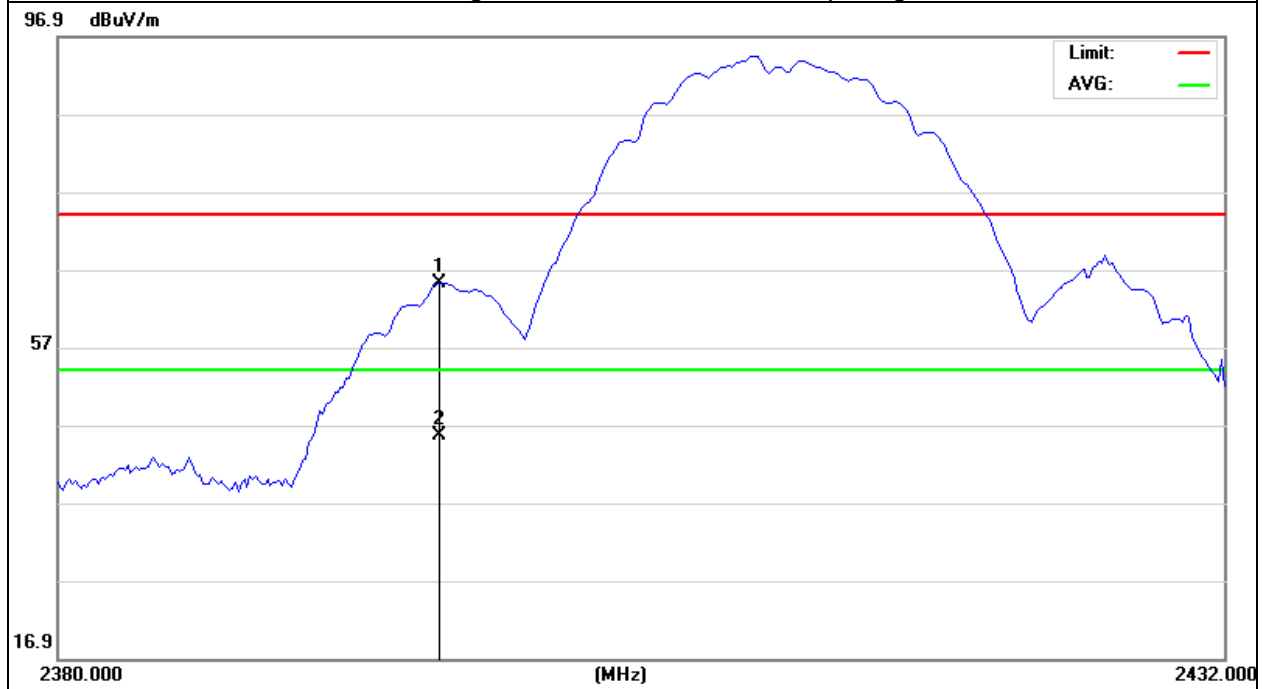



EUT :	MID	Model Name :	MID7326CM
Temperature :	20 °C	Relative Humidity :	48%
Pressure :	1010 hPa	Test Voltage :	DC 5V From Adapter AC 120V/60Hz
Test Mode :	CH11(802.11b Mode)	Polarization :	Horizontal

Frequency (MHz)	Meter Reading (dBμV)	Factor (dB)	Emission Level (dBμV/m)	Limits (dBμV/m)	Margin (dB)	Detector Type
2477.375	84.03	-12.81	71.22	74.00	-2.78	peak
2477.375	58.35	-12.81	45.54	54.00	-8.46	AVG

Remark:

- Factor = Antenna Factor + Cable Loss – Pre-amplifier.
- Set the Lowest and Highest Transmitting Channel, observed the outside band of 2400MHz to 2438.5MHz, then mark the higher-level emission for comparing with the FCC rules.

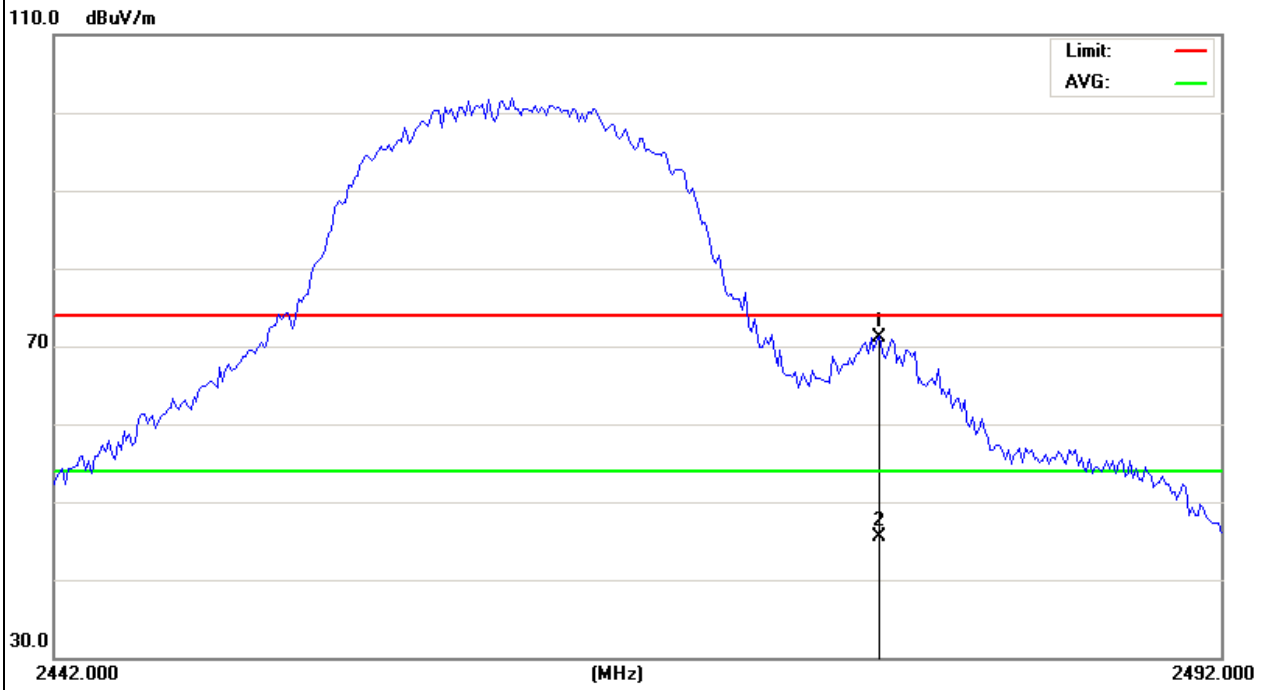

EUT :	MID	Model Name :	MID7326CM
Temperature :	20 °C	Relative Humidity :	48%
Pressure :	1010 hPa	Test Voltage :	DC 5V From Adapter AC 120V/60Hz
Test Mode :	CH1(802.11g Mode)	Polarization :	Horizontal

Frequency (MHz)	Meter Reading (dBμV)	Factor (dB)	Emission Level (dBμV/m)	Limits (dBμV/m)	Margin (dB)	Detector Type
2399.61	85.08	-17.46	67.62	74	-6.38	peak
2399.61	63.24	-17.46	45.78	54	-8.22	AVG

Remark:

- Factor = Antenna Factor + Cable Loss – Pre-amplifier.
- Set the Lowest and Highest Transmitting Channel, observed the outside band of 2400MHz to 2438.5MHz, then mark the higher-level emission for comparing with the FCC rules.

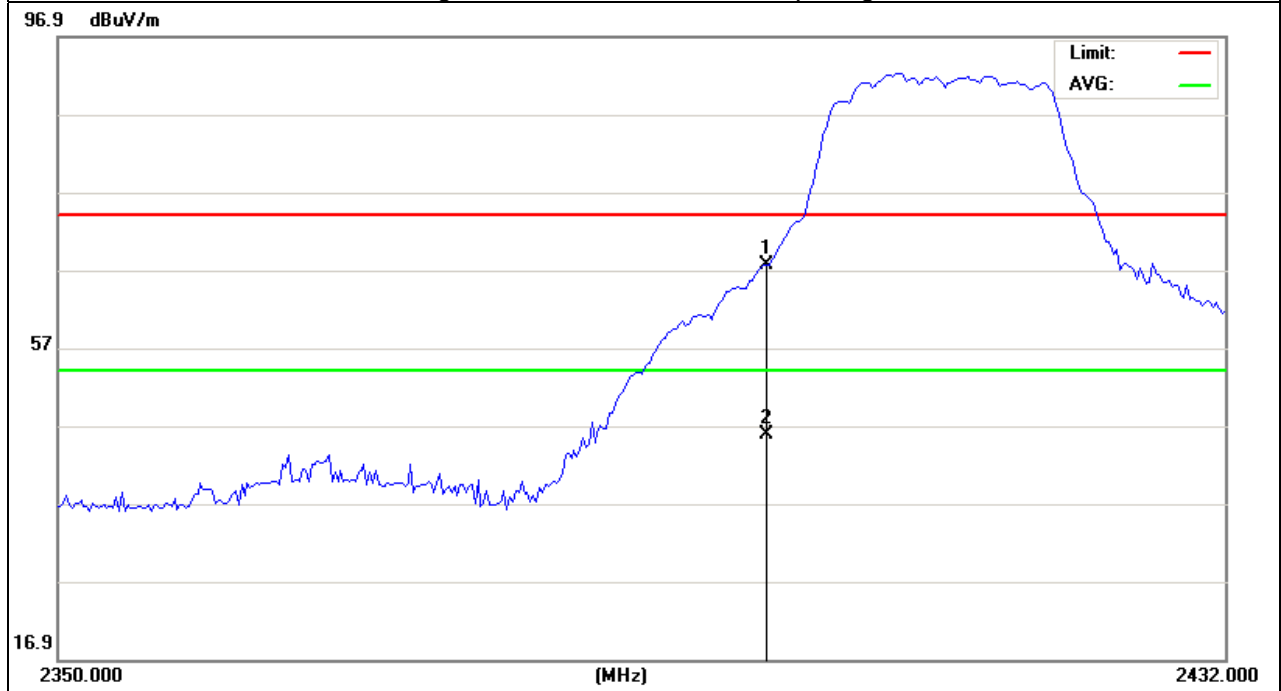

EUT :	MID	Model Name :	MID7326CM
Temperature :	20 °C	Relative Humidity :	48%
Pressure :	1010 hPa	Test Voltage :	DC 5V From Adapter AC 120V/60Hz
Test Mode :	CH11(802.11g Mode)	Polarization :	Horizontal

Frequency (MHz)	Meter Reading (dBμV)	Factor (dB)	Emission Level (dBμV/m)	Limits (dBμV/m)	Margin (dB)	Detector Type
2481.425	85.99	-17.35	68.64	74	-5.36	peak
2481.425	66.54	-17.35	49.19	54	-4.81	AVG

Remark:

- Factor = Antenna Factor + Cable Loss – Pre-amplifier.
- Set the Lowest and Highest Transmitting Channel, observed the outside band of 2400MHz to 2438.5MHz, then mark the higher-level emission for comparing with the FCC rules.

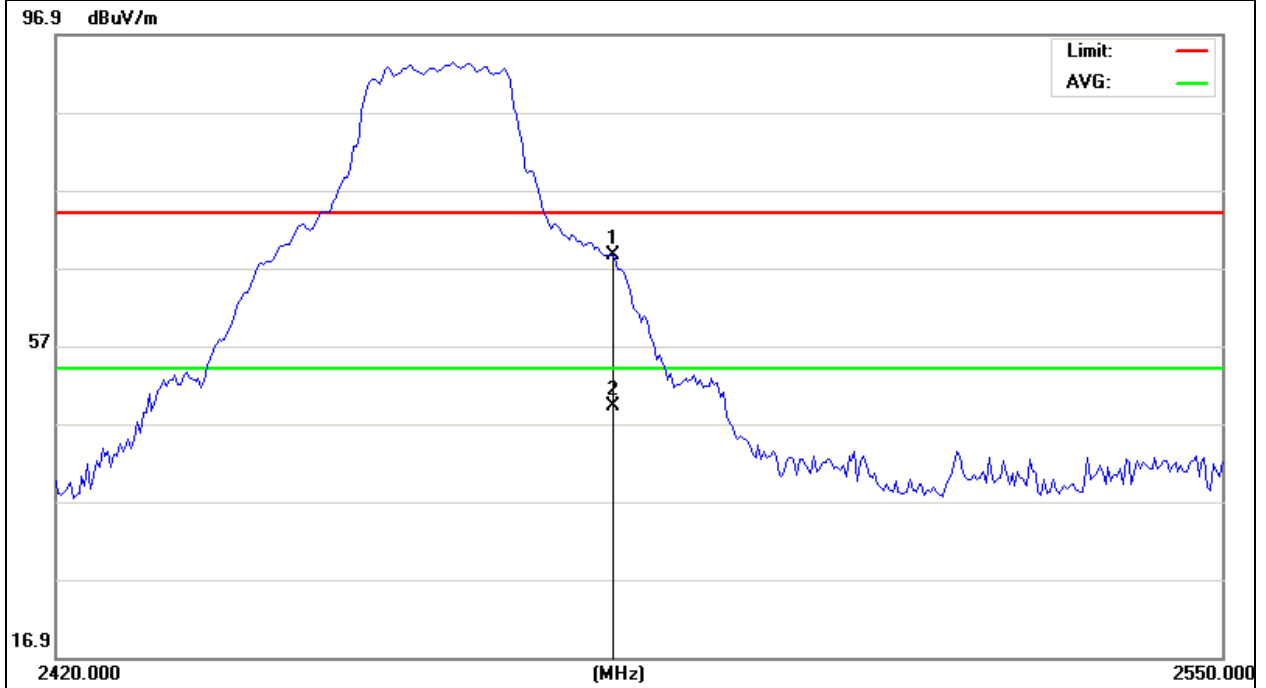

EUT :	MID	Model Name :	MID7326CM
Temperature :	20 °C	Relative Humidity :	48%
Pressure :	1010 hPa	Test Voltage :	DC 5V From Adapter AC 120V/60Hz
Test Mode :	CH1(802.11n Mode/20MHz)	Polarization :	Horizontal

Frequency (MHz)	Meter Reading (dBμV)	Factor (dB)	Emission Level (dBμV/m)	Limits (dBμV/m)	Margin (dB)	Detector Type
2399.2	64.62	-17.46	47.16	54	-6.84	AVG
2399.61	84.89	-17.46	67.43	74	-6.57	peak

Remark:

- Factor = Antenna Factor + Cable Loss – Pre-amplifier.
- Set the Lowest and Highest Transmitting Channel, observed the outside band of 2400MHz to 2438.5MHz, then mark the higher-level emission for comparing with the FCC rules.

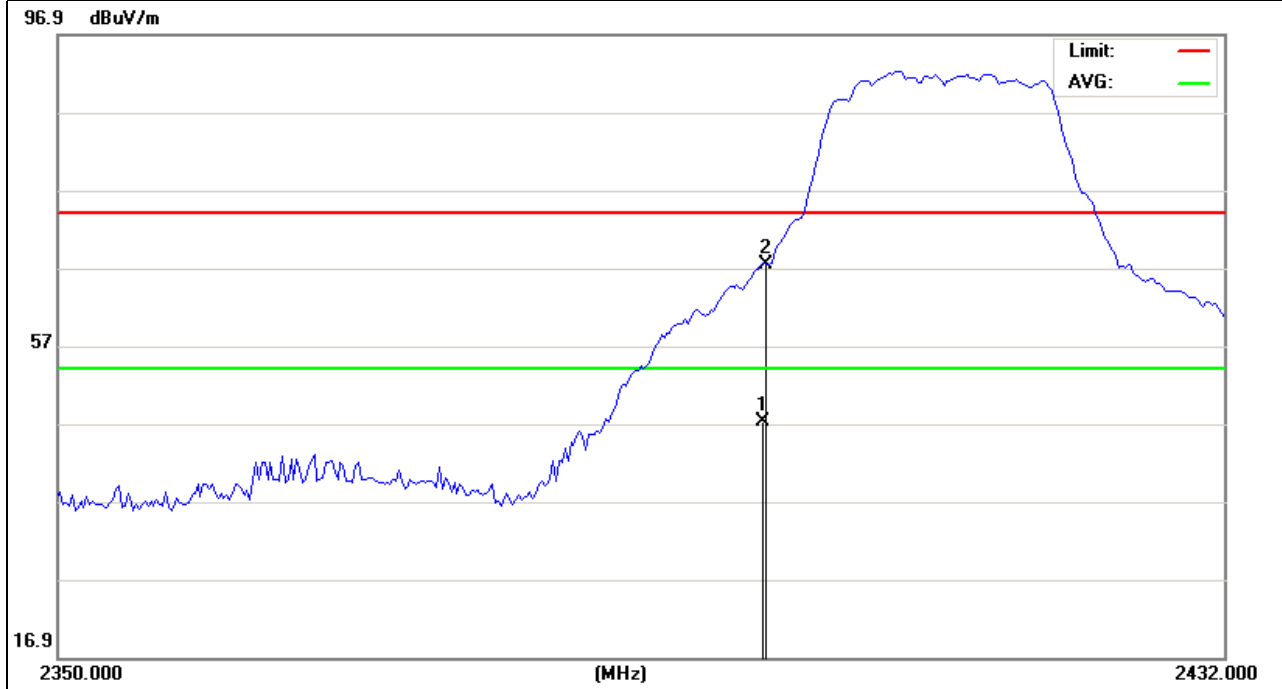

EUT :	MID	Model Name :	MID7326CM
Temperature :	20 °C	Relative Humidity :	48%
Pressure :	1010 hPa	Test Voltage :	DC 5V From Adapter AC 120V/60Hz
Test Mode :	CH11(802.11n Mode/20MHz)	Polarization :	Horizontal

Frequency (MHz)	Meter Reading (dBμV)	Factor (dB)	Emission Level (dBμV/m)	Limits (dBμV/m)	Margin (dB)	Detector Type
2482.725	89.3	-17.35	71.95	74	-2.05	peak
2482.725	70.04	-17.35	52.69	54	-1.31	AVG

Remark:

- Factor = Antenna Factor + Cable Loss – Pre-amplifier.
- Set the Lowest and Highest Transmitting Channel, observed the outside band of 2400MHz to 2438.5MHz, then mark the higher-level emission for comparing with the FCC rules.

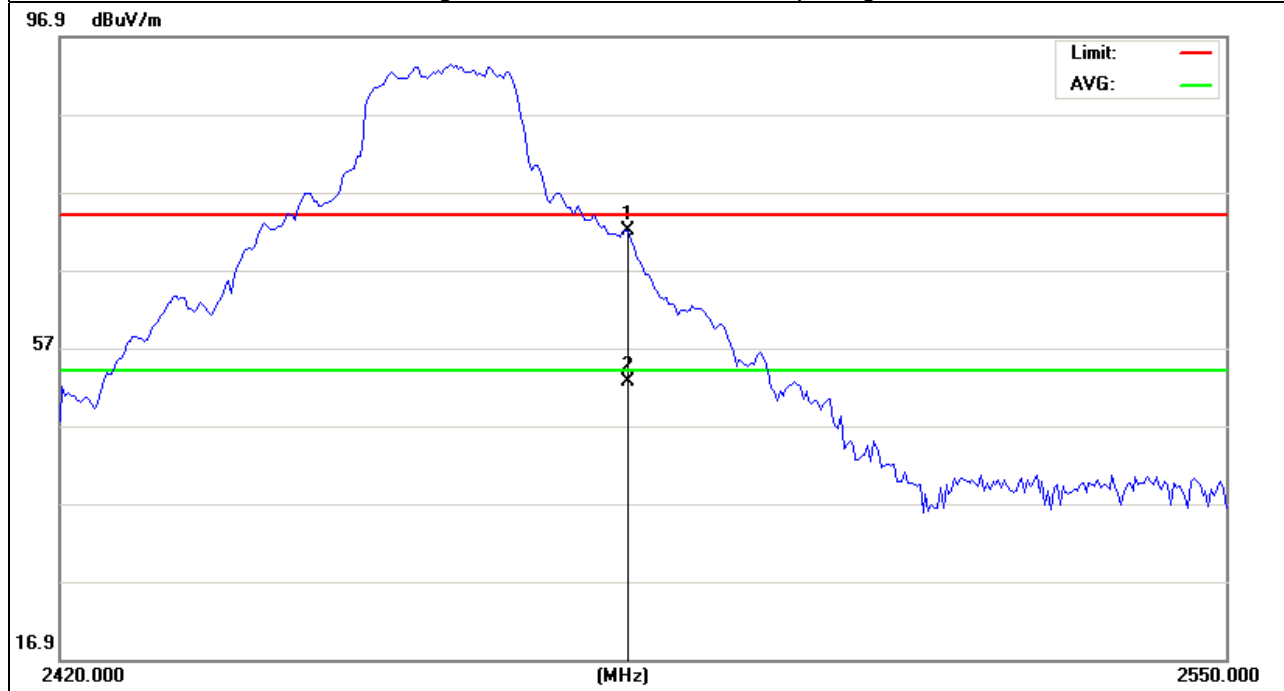

EUT :	MID	Model Name :	MID7326CM
Temperature :	20 °C	Relative Humidity :	48%
Pressure :	1010 hPa	Test Voltage :	DC 5V From Adapter AC 120V/60Hz
Test Mode :	CH3(802.11n Mode/40MHz)	Polarization :	Horizontal

Frequency (MHz)	Meter Reading (dBµV)	Factor (dB)	Emission Level (dBµV/m)	Limits (dBµV/m)	Margin (dB)	Detector Type
2401	84.81	-17.46	67.35	74	-6.65	peak
2401	60.15	-17.46	42.69	54	-11.31	AVG

Remark:

- Factor = Antenna Factor + Cable Loss – Pre-amplifier.
- Set the Lowest and Highest Transmitting Channel, observed the outside band of 2400MHz to 2438.5MHz, then mark the higher-level emission for comparing with the FCC rules.

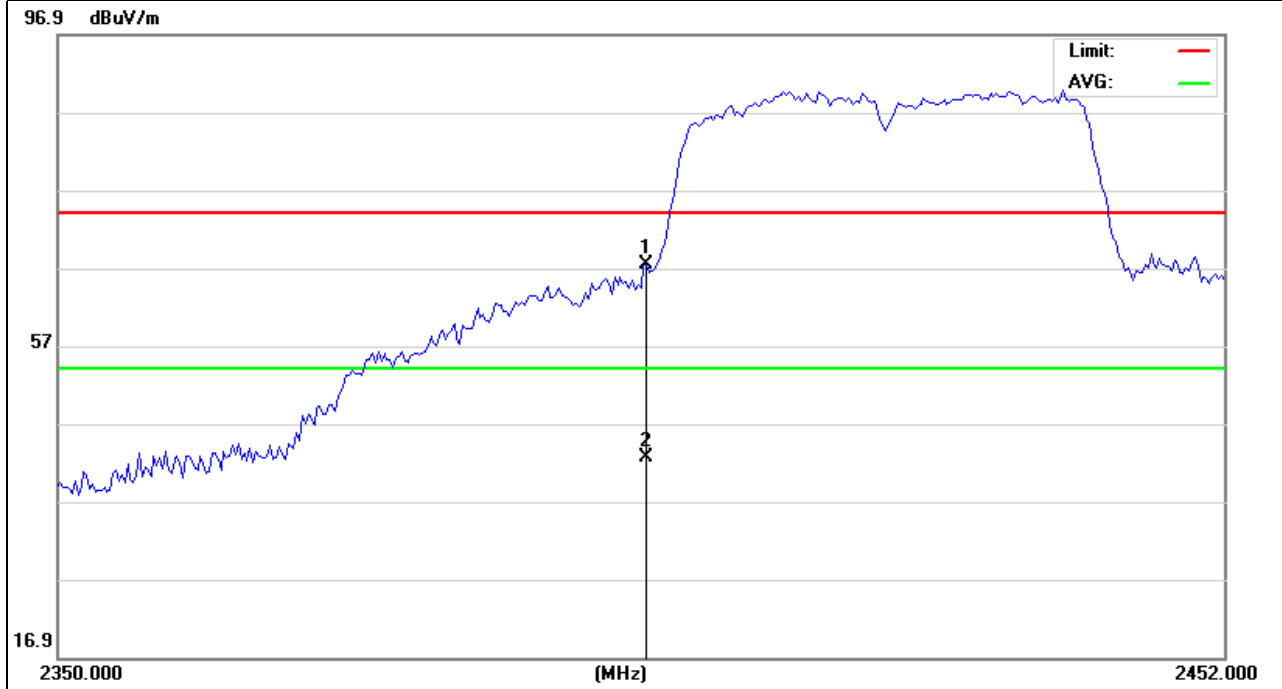

EUT :	MID	Model Name :	MID7326CM
Temperature :	20 °C	Relative Humidity :	48%
Pressure :	1010 hPa	Test Voltage :	DC 5V From Adapter AC 120V/60Hz
Test Mode :	CH9(802.11n Mode/40MHz)	Polarization :	Horizontal

Frequency (MHz)	Meter Reading (dBμV)	Factor (dB)	Emission Level (dBμV/m)	Limits (dBμV/m)	Margin (dB)	Detector Type
2484.025	84.49	-17.35	67.14	74	-6.86	peak
2484.025	67.03	-17.35	49.68	54	-4.32	AVG

Remark:

- Factor = Antenna Factor + Cable Loss – Pre-amplifier.
- Set the Lowest and Highest Transmitting Channel, observed the outside band of 2400MHz to 2438.5MHz, then mark the higher-level emission for comparing with the FCC rules.

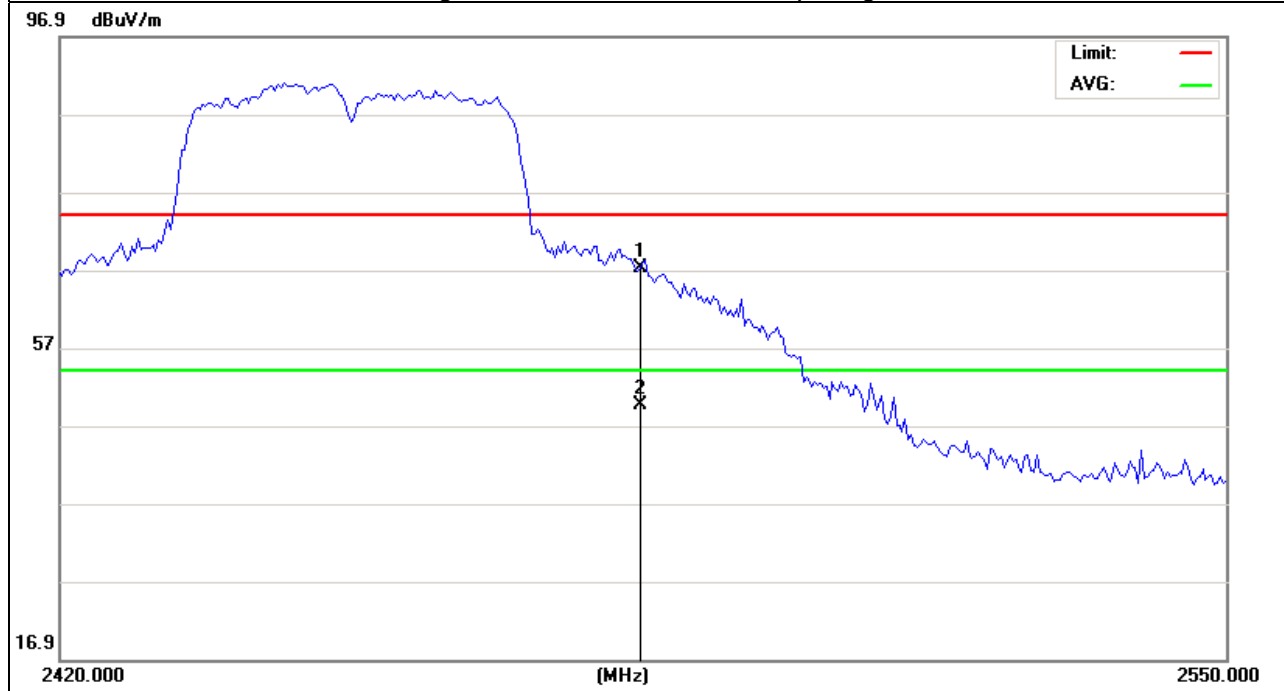

#### 4. POWER SPECTRAL DENSITY TEST

##### 4.1 APPLIED PROCEDURES / LIMIT

FCC Part15 (15.247) , Subpart C				
Section	Test Item	Limit	Frequency Range (MHz)	Result
15.247	Power Spectral Density	8 dBm (in any 3KHz)	2400-2483.5	PASS

##### 4.1.1 TEST PROCEDURE

1. The testing follows Measurement Procedure PKPSD of FCC KDB Publication No. 558074 D01 DTS Meas. Guidance v01.
2. The RF output of EUT was connected to the spectrum analyzer by a low loss cable. The path loss was compensated to the results for each measurement.
3. Record the measurement data derived from spectrum analyzer.
4. Make the measurement with the spectrum analyzer's resolution bandwidth (RBW) = 100 KHz. Video bandwidth (VBW) >= 300 KHz In order to make an accurate measurement, set the span to 5-30% greater than Emission Bandwidth (EBW)
5. Detector = peak, Sweep time = auto couple, Trace mode = max hold, Allow trace to fully stabilize. Use the peak marker function to determine the maximum power level in any 100 kHz band segment within the fundamental EBW.
6. Scale the observed power level to an equivalent value in 3 kHz by adjusting (reducing) the measured power by a bandwidth correction factor (BWCF) where  $BWCF = 10\log(3\text{ kHz}/100\text{ kHz}) = -15.2\text{ dB}$ .

##### 4.1.2 DEVIATION FROM STANDARD

No deviation.

##### 4.1.3 TEST SETUP



##### 4.1.4 EUT OPERATION CONDITIONS

The EUT tested system was configured as the statements of 2.1 Unless otherwise a special operating condition is specified in the follows during the testing.



### 4.1.5 TEST RESULTS

EUT :	MID	Model Name :	MID7326CM
Temperature :	25 °C	Relative Humidity :	60%
Pressure :	1015 hPa	Test Voltage :	DC 5V From Adapter AC 120V/60Hz
Test Mode :	TX b Mode /CH01, CH06, CH11		

Frequency	Power Density A (dBm)	PSD/3KHz (dBm)	Limit (dBm)	Result
2412 MHz	0.037	-15.163	8	<b>PASS</b>
2437 MHz	0.903	-14.297	8	<b>PASS</b>
2462 MHz	-0.087	-15.287	8	<b>PASS</b>

**Note:**

1. BWCF =  $10\log(3\text{ kHz}/100\text{ kHz}) = -15.2\text{ dB}$ .

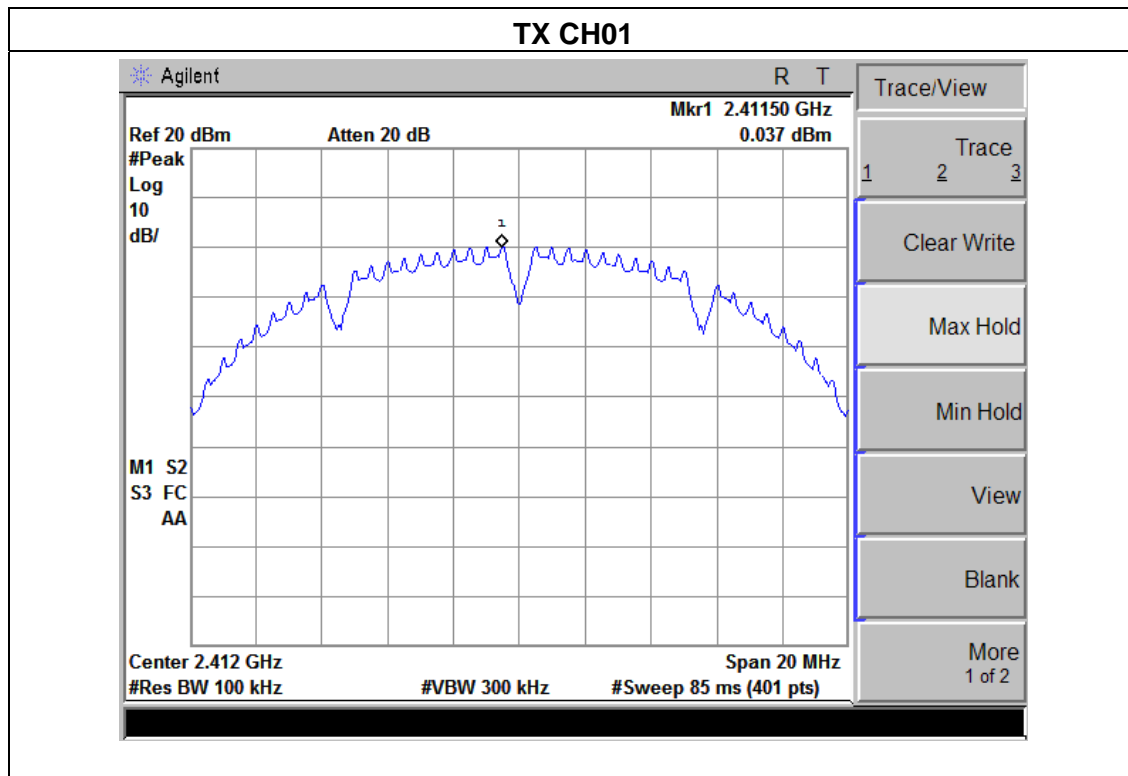

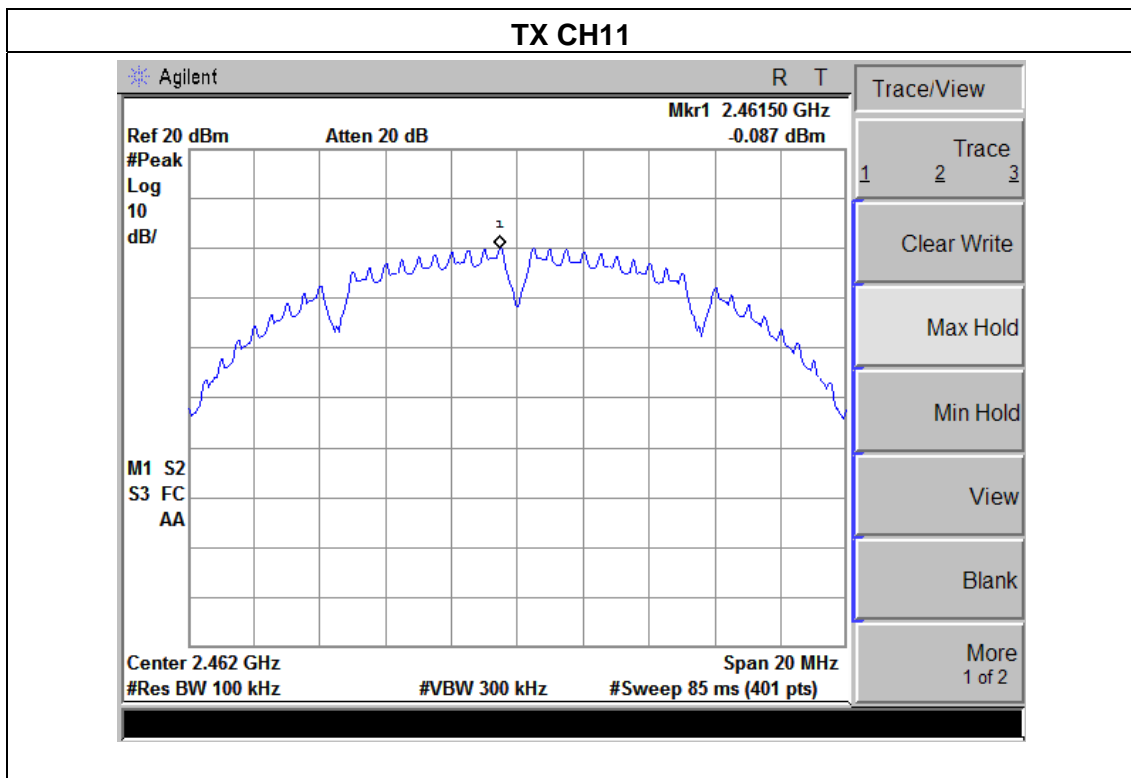
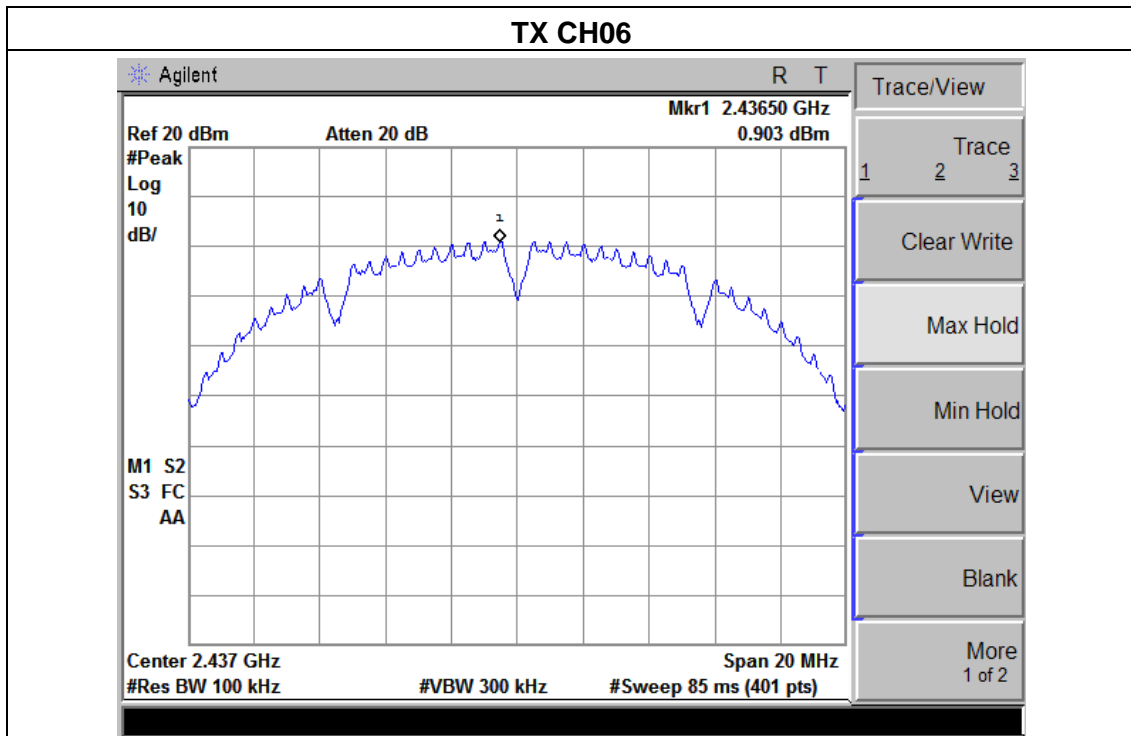

EUT :	MID	Model Name :	MID7326CM
Temperature :	25 °C	Relative Humidity :	60%
Pressure :	1015 hPa	Test Voltage :	DC 5V From Adapter AC 120V/60Hz
Test Mode :	TX g Mode /CH01, CH06, CH11		

Frequency	Power Density A (dBm)	PSD/3KHz (dBm)	Limit (dBm)	Result
2412 MHz	-4.027	-19.227	8	<b>PASS</b>
2437 MHz	-2.073	-17.273	8	<b>PASS</b>
2462 MHz	-4.154	-19.354	8	<b>PASS</b>

**Note:**

1. BWCF =  $10\log(3\text{ kHz}/100\text{ kHz}) = -15.2\text{ dB}$ .

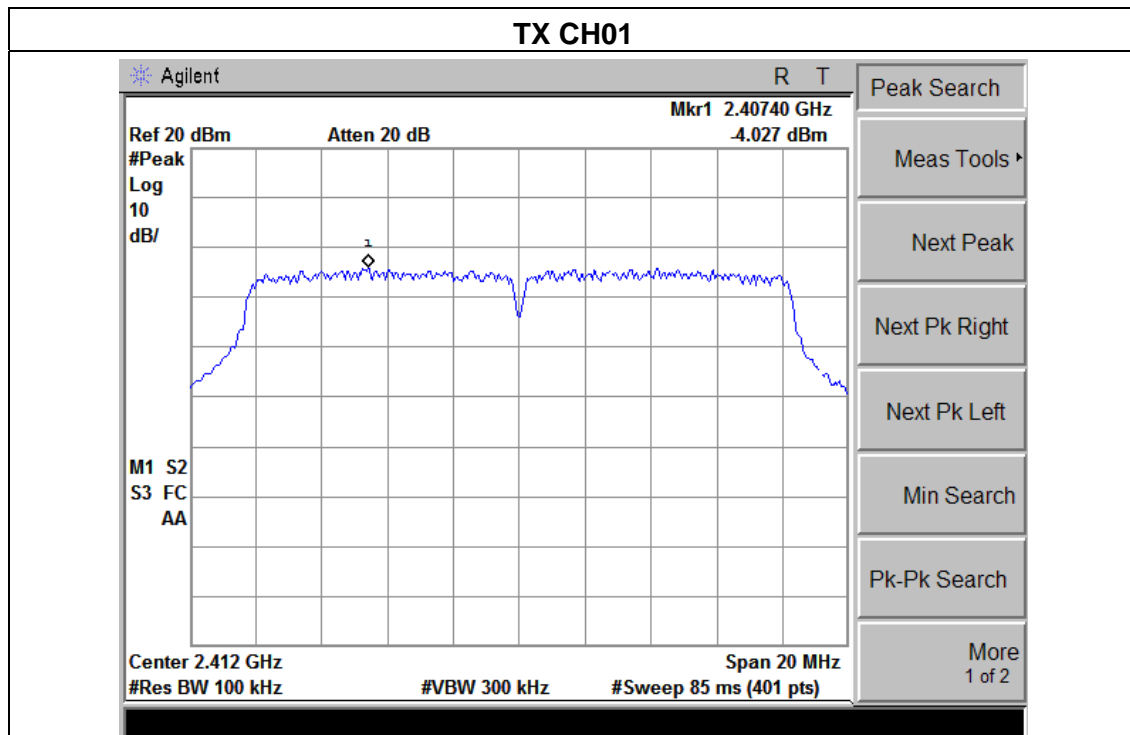

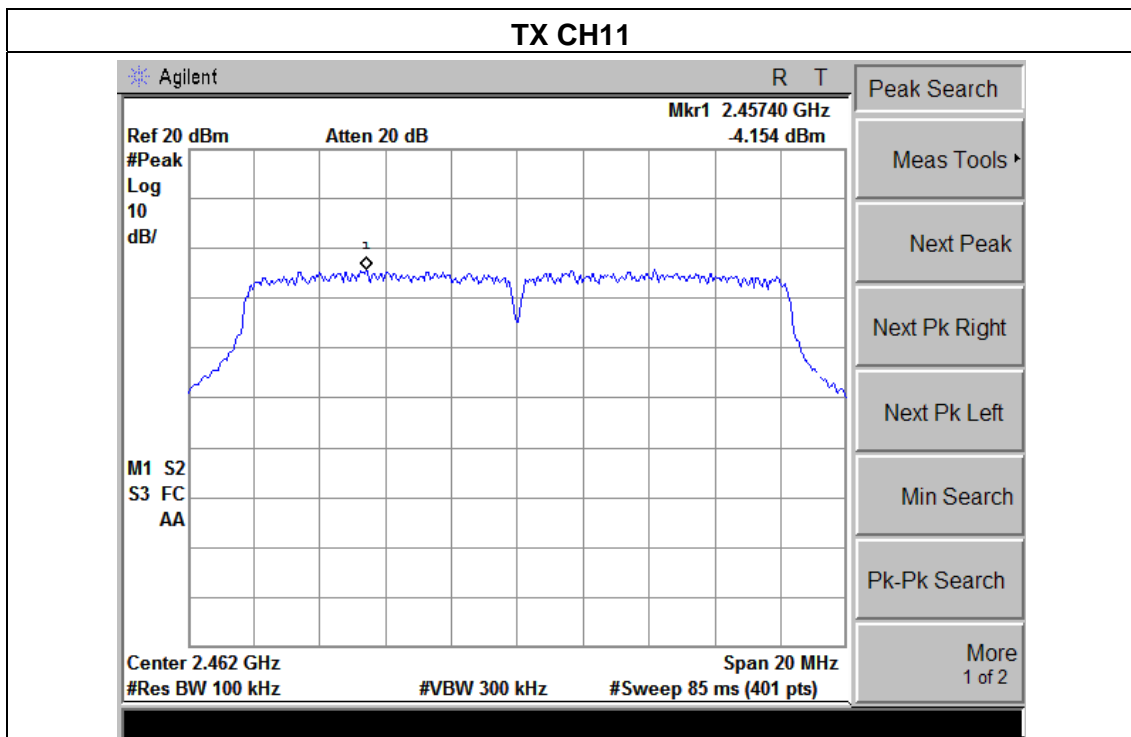
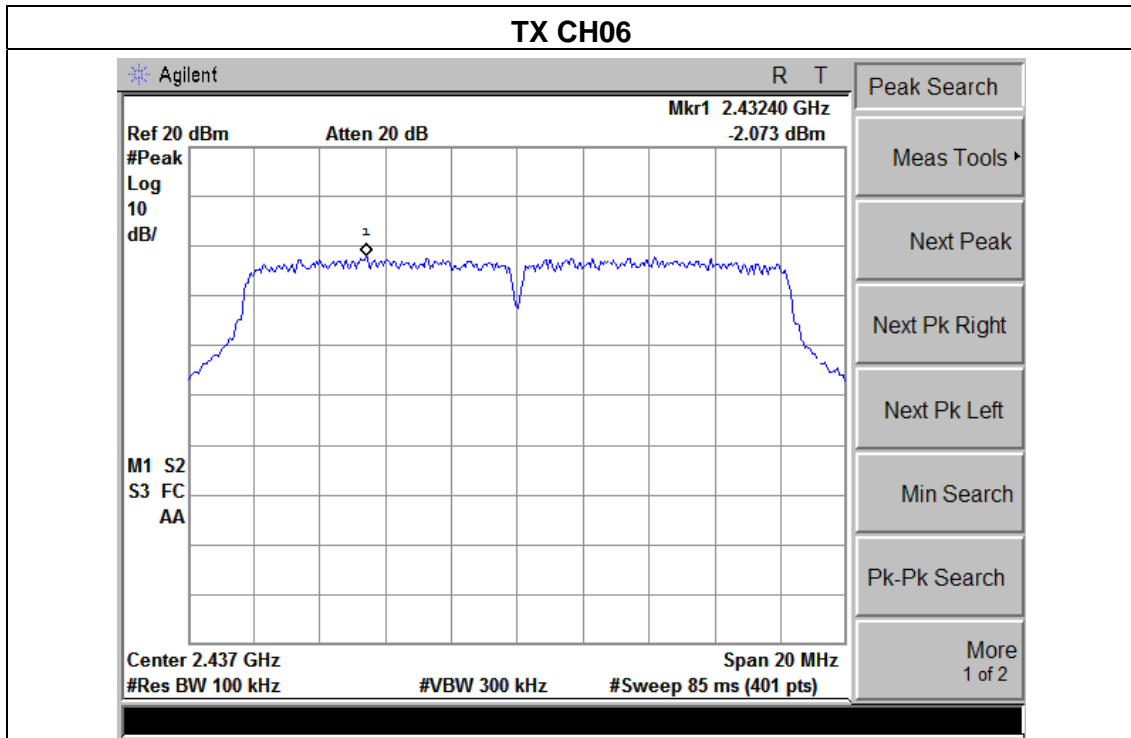

EUT :	MID	Model Name :	MID7326CM
Temperature :	25 °C	Relative Humidity :	60%
Pressure :	1015 hPa	Test Voltage :	DC 5V From Adapter AC 120V/60Hz
Test Mode :	TX n Mode(20M) /CH01, CH06, CH11		

Frequency	Power Density A (dBm)	PSD/ 3KHz (dBm)	Limit (dBm)	Result
2412 MHz	-4.119	-19.319	8	<b>PASS</b>
2437 MHz	-5.806	-21.006	8	<b>PASS</b>
2462 MHz	-5.222	-20.422	8	<b>PASS</b>

**Note:**

1. BWCF =  $10\log(3\text{ kHz}/100\text{ kHz}) = -15.2\text{ dB}$ .

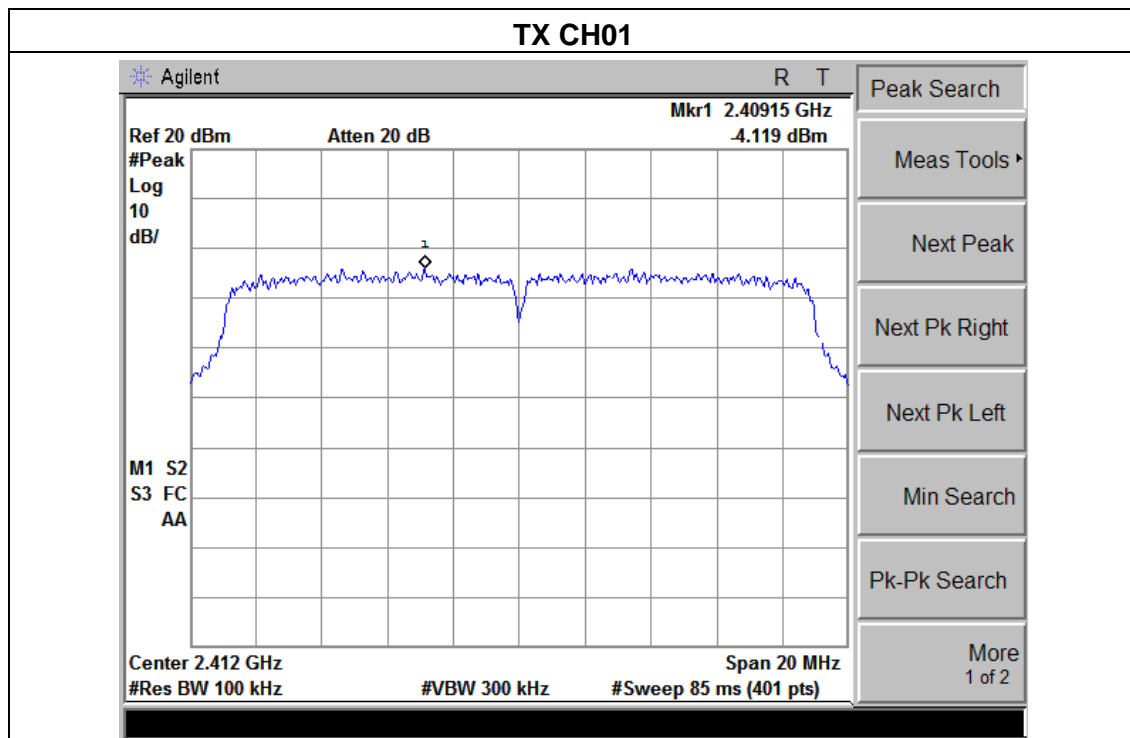

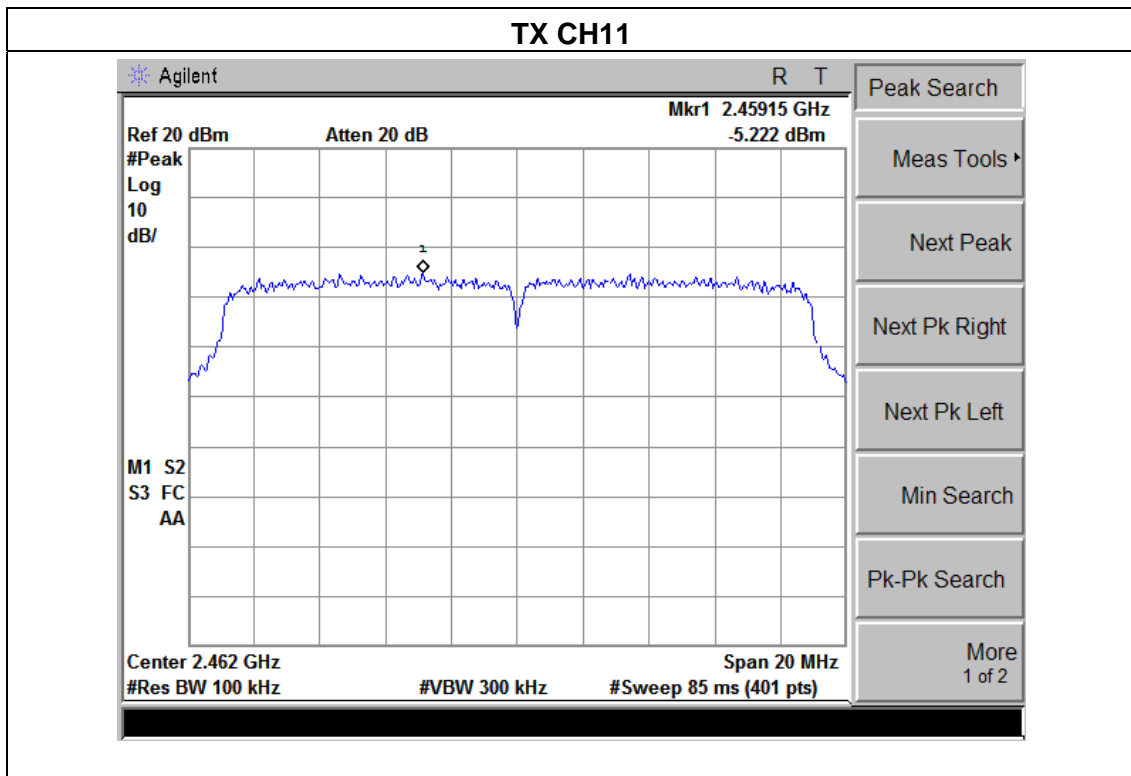
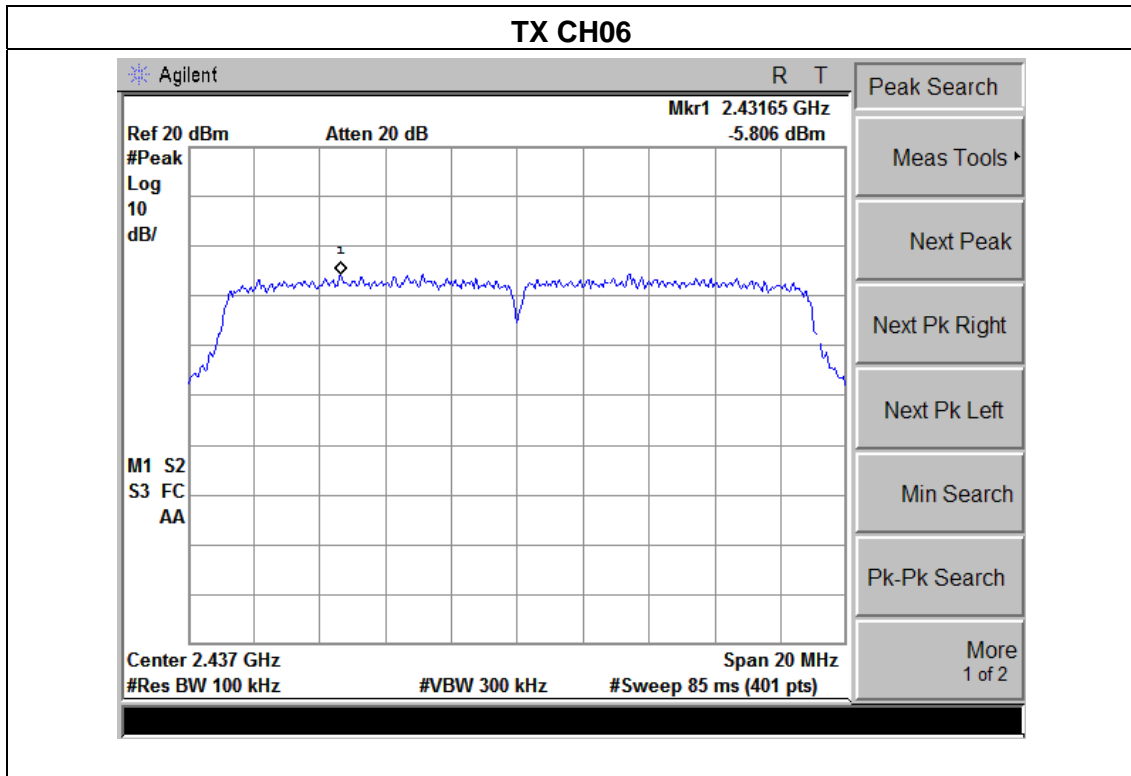

EUT :	MID	Model Name :	MID7326CM
Temperature :	25 °C	Relative Humidity :	60%
Pressure :	1015 hPa	Test Voltage :	DC 5V From Adapter AC 120V/60Hz
Test Mode :	TX n Mode(40M) /CH03, CH06, CH09		

Frequency	Power Density A (dBm)	PSD/ 3KHz (dBm)	Limit (dBm)	Result
2422 MHz	-8.857	-24.057	8	<b>PASS</b>
2437 MHz	-6.707	-21.907	8	<b>PASS</b>
2452 MHz	-6.096	-21.296	8	<b>PASS</b>

**Note:**

1. BWCF =  $10\log(3\text{ kHz}/100\text{ kHz} = -15.2\text{ dB})$ .

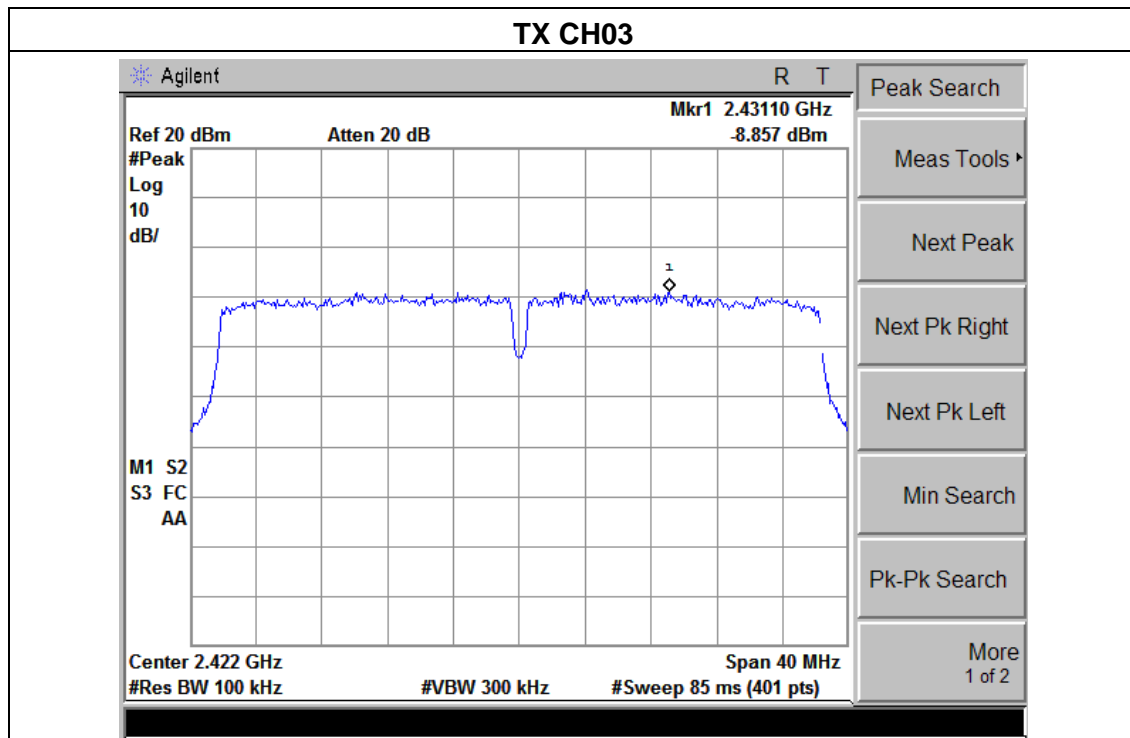

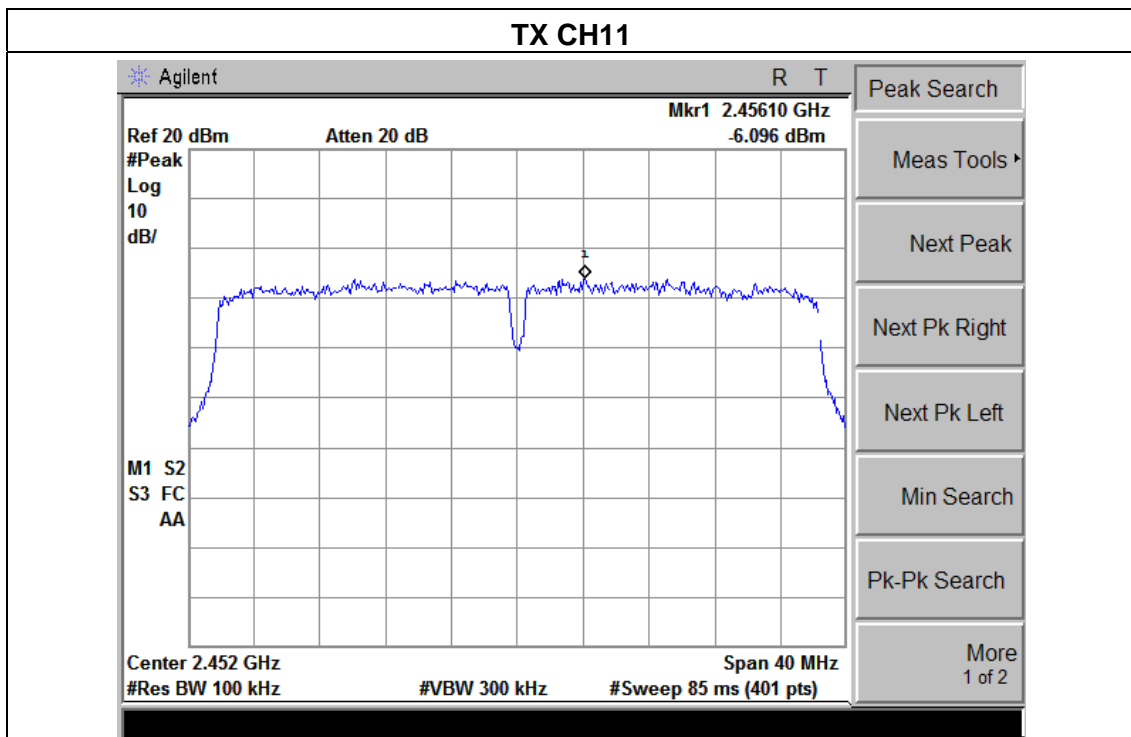
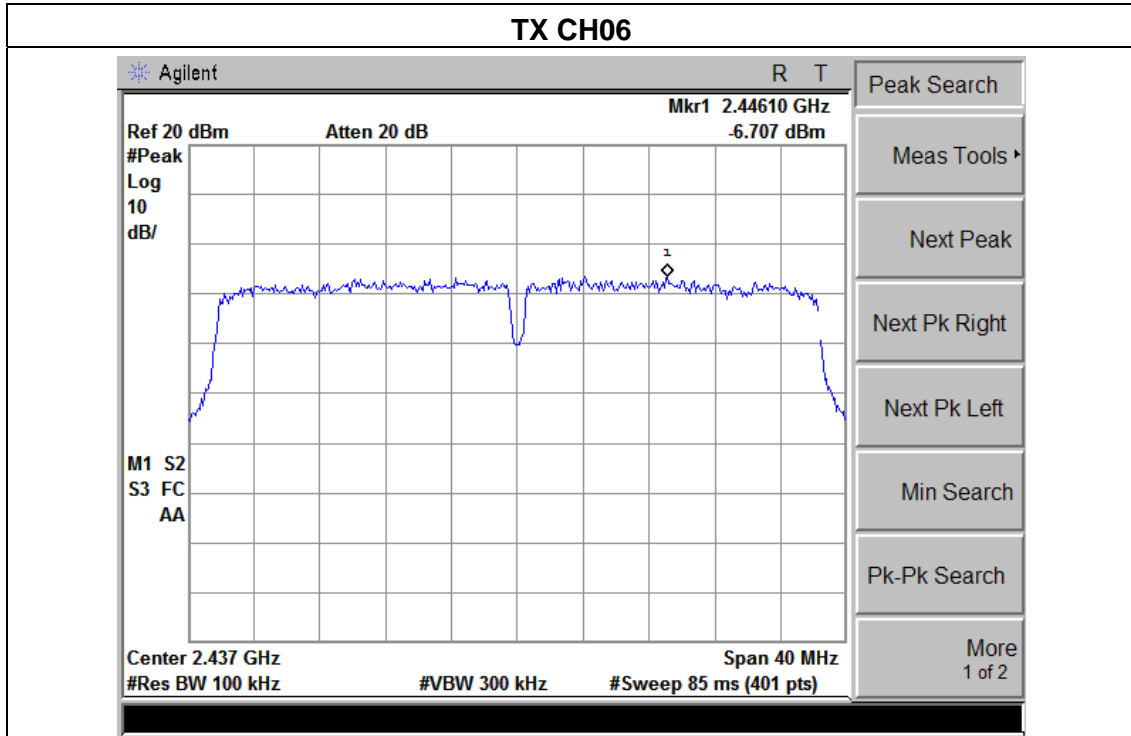



## 5. BANDWIDTH TEST

### 5.1 APPLIED PROCEDURES / LIMIT

FCC Part15 (15.247) , Subpart C				
Section	Test Item	Limit	Frequency Range (MHz)	Result
15.247(a)(2)	Bandwidth	$\geq 500\text{KHz}$ (6dB bandwidth)	2400-2483.5	PASS

#### 5.1.1 TEST PROCEDURE

- a.
1. The testing follows FCC KDB Publication No. 558074 D01 DTS Meas. Guidance v01.
  2. The RF output of EUT was connected to the spectrum analyzer by a low loss cable. The path loss was compensated to the results for each measurement.
  3. Make the measurement with the spectrum analyzer's resolution bandwidth (RBW) = 1-5% of the emission bandwidth (EBW). Set the Video bandwidth (VBW)  $\geq 3 * \text{RBW}$ . In order to make an accurate measurement. The 6 dB bandwidth must be greater than 500 KHz.
  4. The marker-delta reading at this point is the 6 dB bandwidth of the emission.

#### 5.1.2 DEVIATION FROM STANDARD

No deviation.

#### 5.1.3 TEST SETUP



#### 5.1.4 EUT OPERATION CONDITIONS

The EUT tested system was configured as the statements of 2.4 Unless otherwise a special operating condition is specified in the follows during the testing.

### 5.1.5 TEST RESULTS

EUT :	MID	Model Name :	MID7326CM
Temperature :	25 °C	Relative Humidity :	60%
Pressure :	1012 hPa	Test Voltage :	DC 5V From Adapter AC 120V/60Hz
Test Mode :	TX b Mode /CH01, CH06, CH11		

Frequency	6dB Bandwidth (MHz)	99% Occupied BW (MHz)	Channel Separation (MHz)	Result
2412 MHz	10.063	14.8855	>=500KHz	<b>PASS</b>
2437 MHz	10.084	14.8633	>=500KHz	<b>PASS</b>
2462 MHz	10.071	14.8676	>=500KHz	<b>PASS</b>

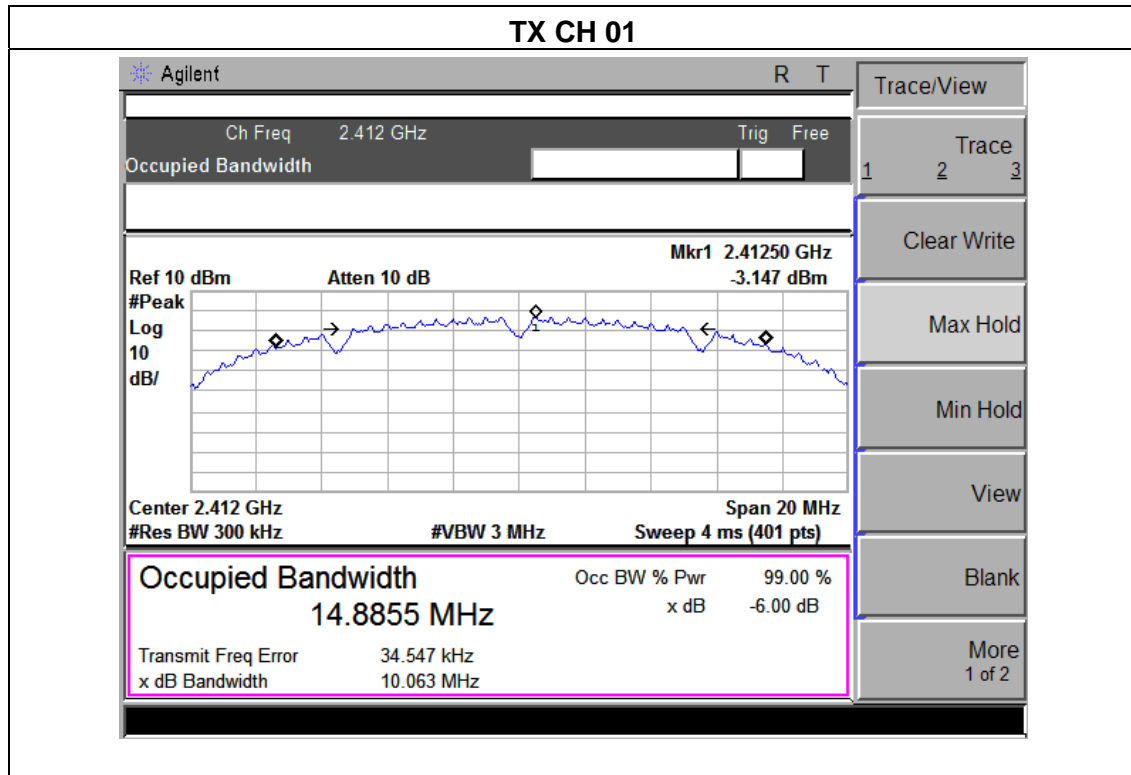

### TX CH 06

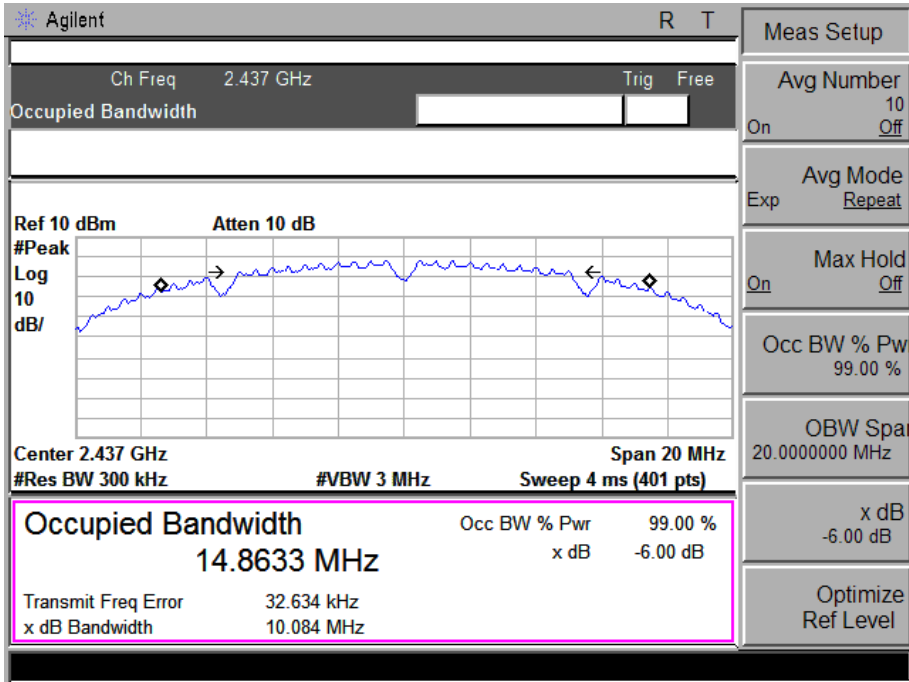

### TX CH 11

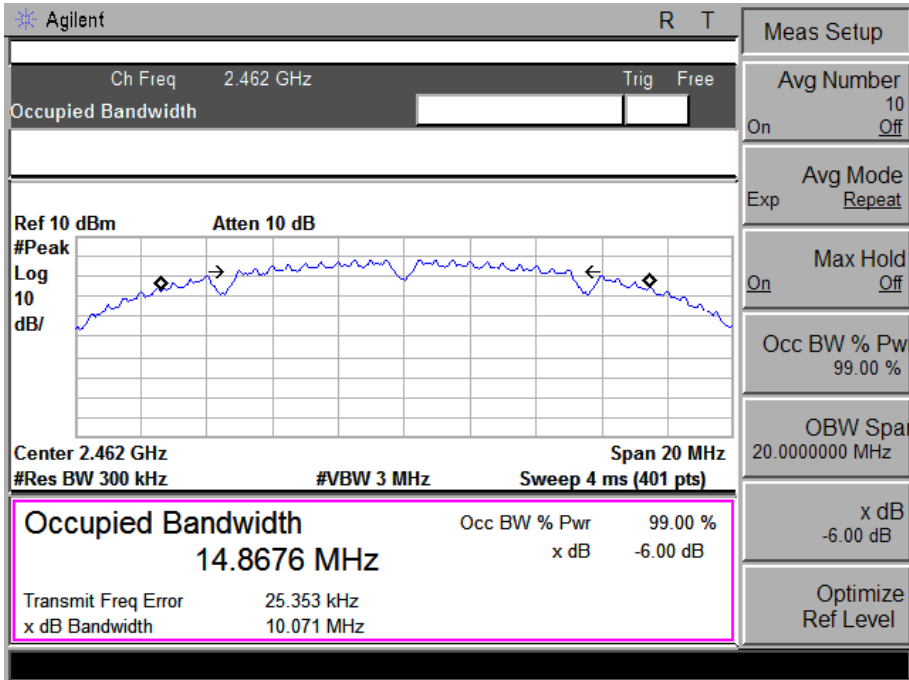

EUT :	MID	Model Name :	MID7326CM
Temperature :	25 °C	Relative Humidity :	60%
Pressure :	1012 hPa	Test Voltage :	DC 5V From Adapter AC 120V/60Hz
Test Mode :	TX g Mode /CH01, CH06, CH11		

Frequency	6dB Bandwidth (MHz)	99% Occupied BW (MHz)	Channel Separation (MHz)	Result
2412 MHz	16.533	16.4295	>=500KHz	<b>PASS</b>
2437 MHz	16.560	16.4348	>=500KHz	<b>PASS</b>
2462 MHz	16.569	16.4348	>=500KHz	<b>PASS</b>

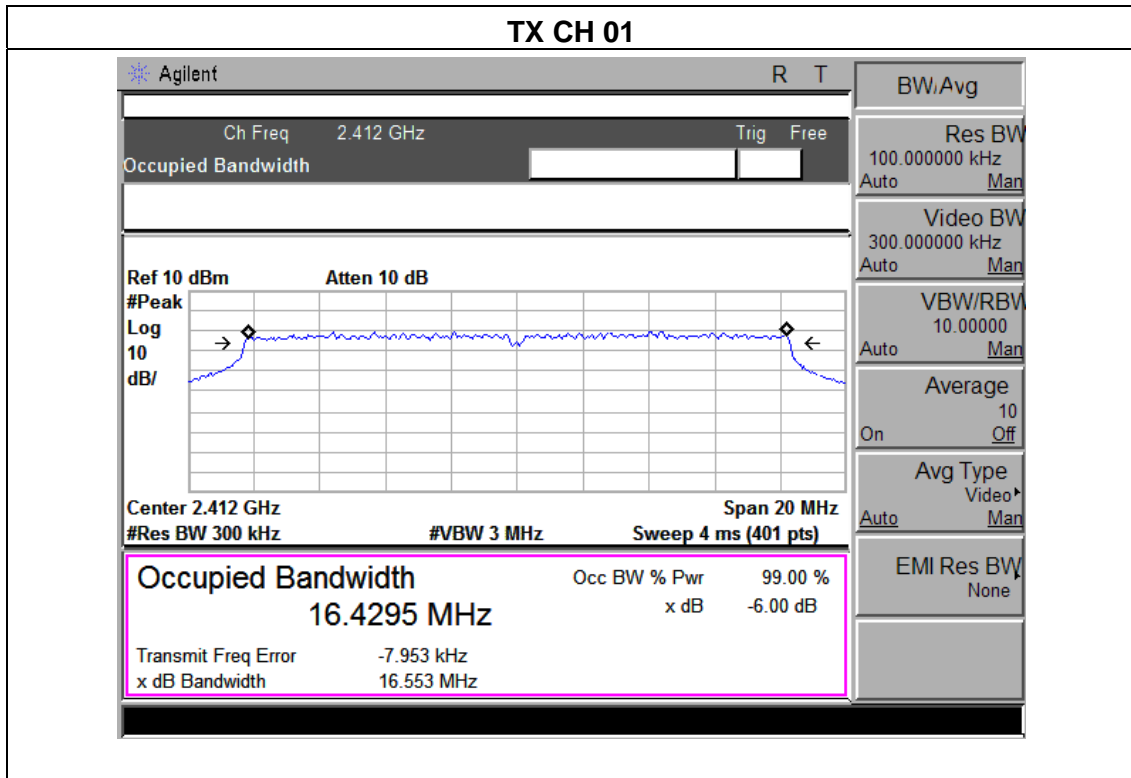

### TX CH 06

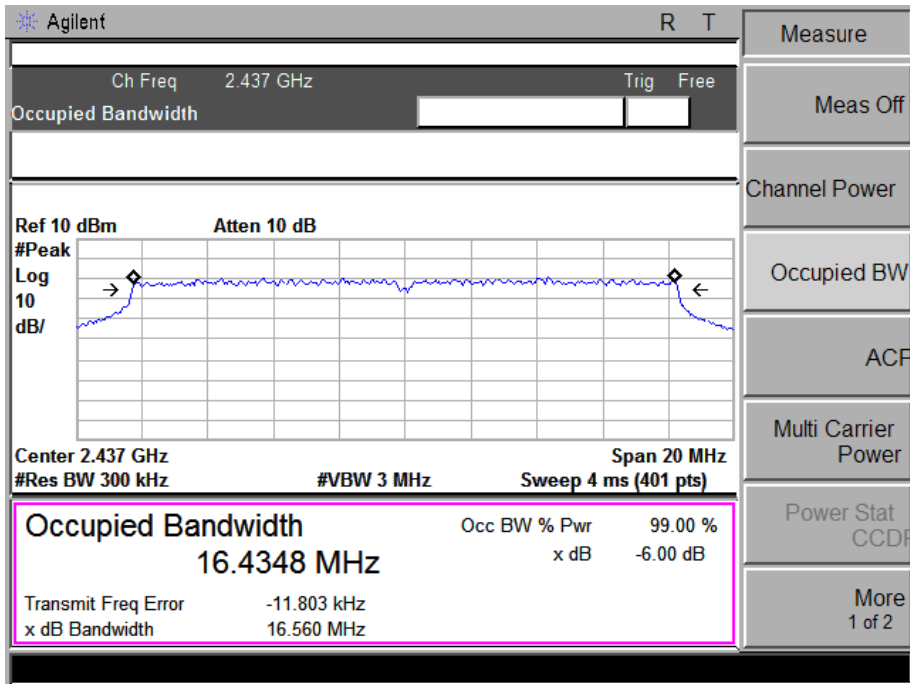

### TX CH 11

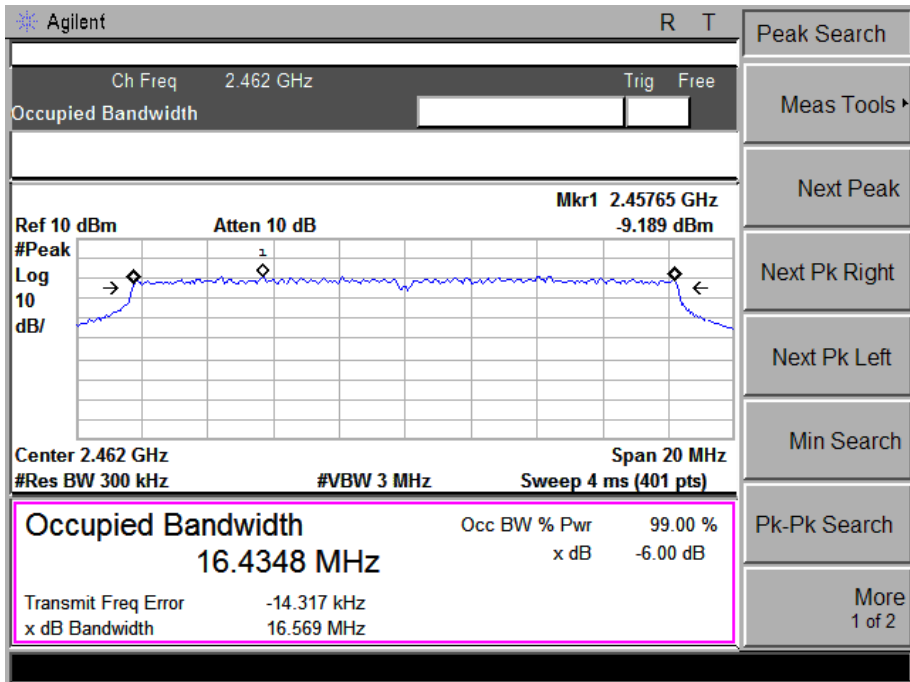

EUT :	MID	Model Name :	MID7326CM
Temperature :	25 °C	Relative Humidity :	60%
Pressure :	1012 hPa	Test Voltage :	DC 5V From Adapter AC 120V/60Hz
Test Mode :	TX n Mode(20M) /CH01, CH06, CH11		

Frequency	6dB Bandwidth (MHz)	99% Occupied BW (MHz)	Channel Separation (MHz)	Result
2412 MHz	17.814	17.6242	>=500KHz	<b>PASS</b>
2437 MHz	17.826	17.6371	>=500KHz	<b>PASS</b>
2462 MHz	17.817	17.6277	>=500KHz	<b>PASS</b>

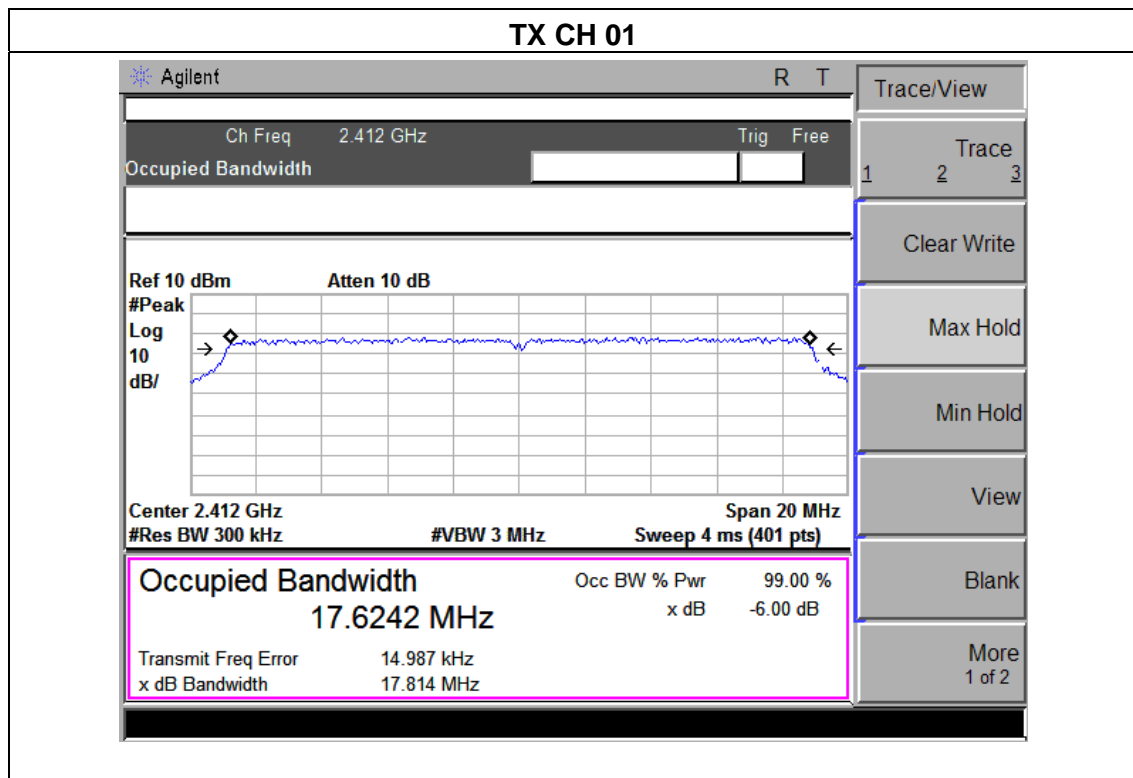

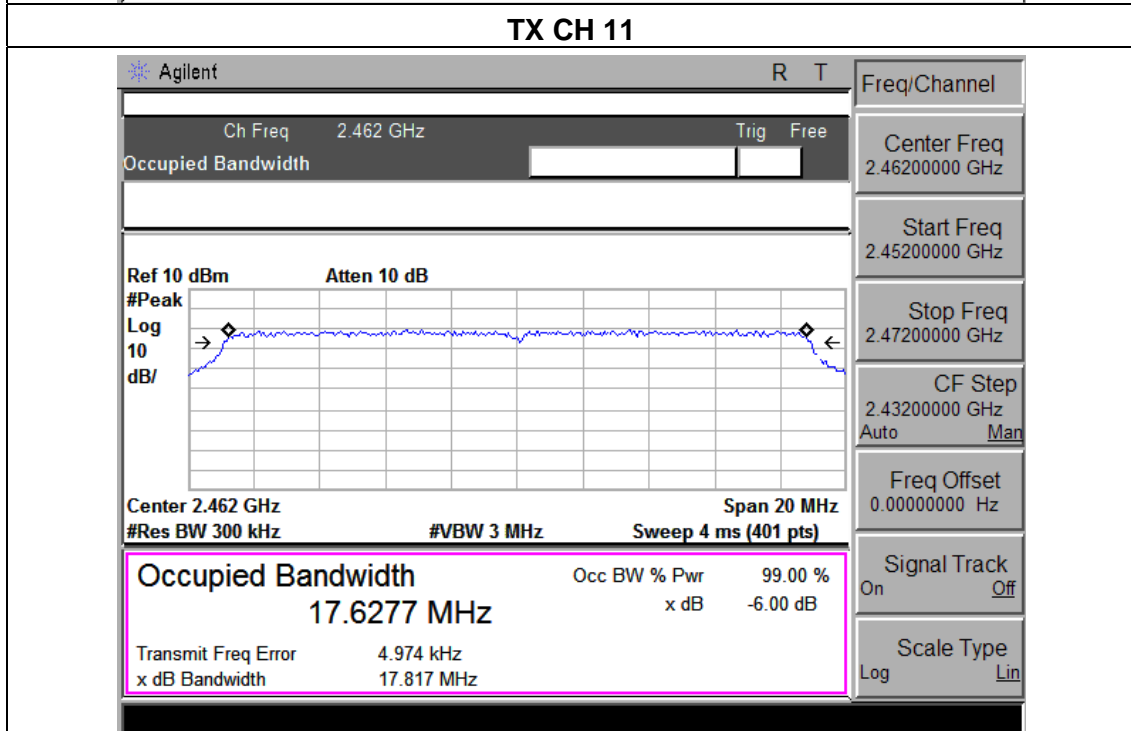
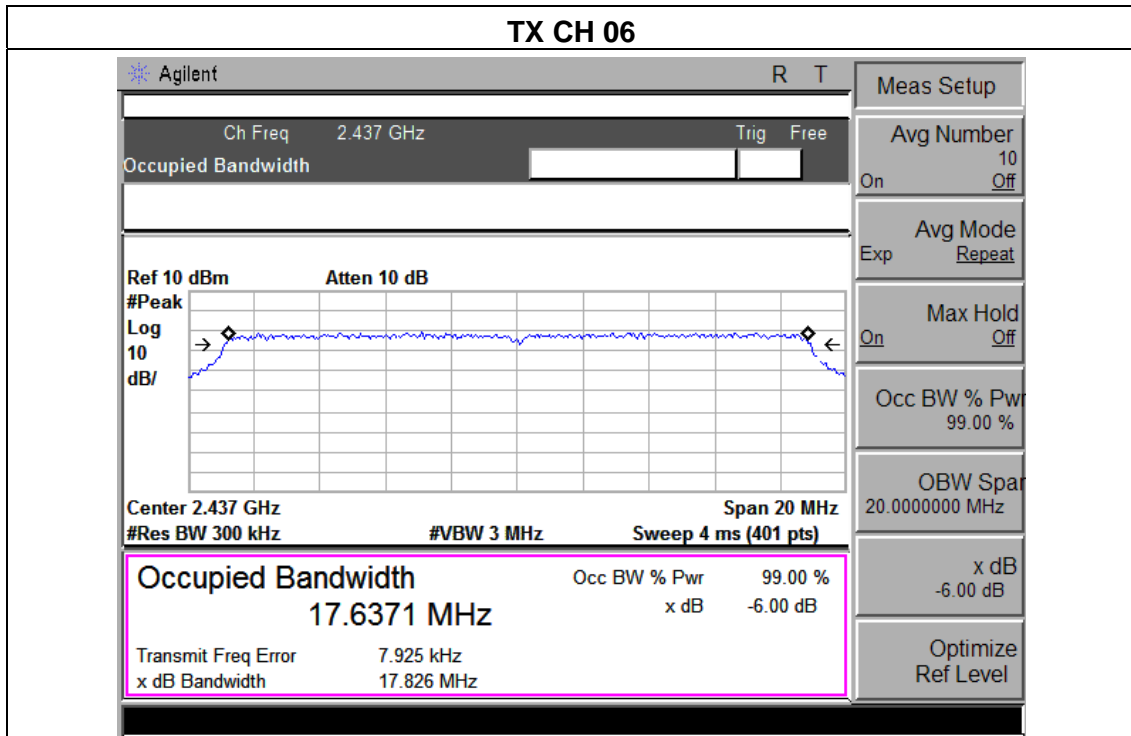

EUT :	MID	Model Name :	MID7326CM
Temperature :	25 °C	Relative Humidity :	60%
Pressure :	1012 hPa	Test Voltage :	DC 5V From Adapter AC 120V/60Hz
Test Mode :	TX n Mode(40M) /CH03, CH06, CH09		

Frequency	6dB Bandwidth (MHz)	99% Occupied BW (MHz)	Channel Separation (MHz)	Result
2422 MHz	36.067	35.7742	>=500KHz	<b>PASS</b>
2437 MHz	36.135	35.7675	>=500KHz	<b>PASS</b>
2452 MHz	36.143	35.7673	>=500KHz	<b>PASS</b>

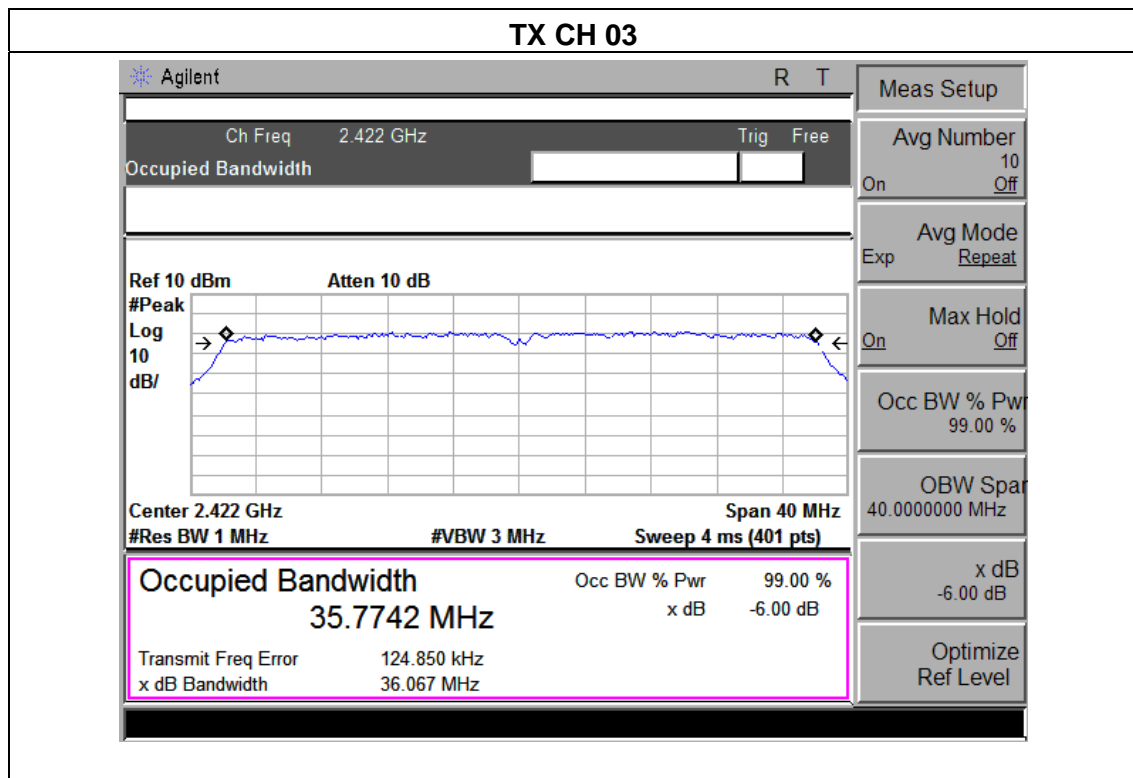



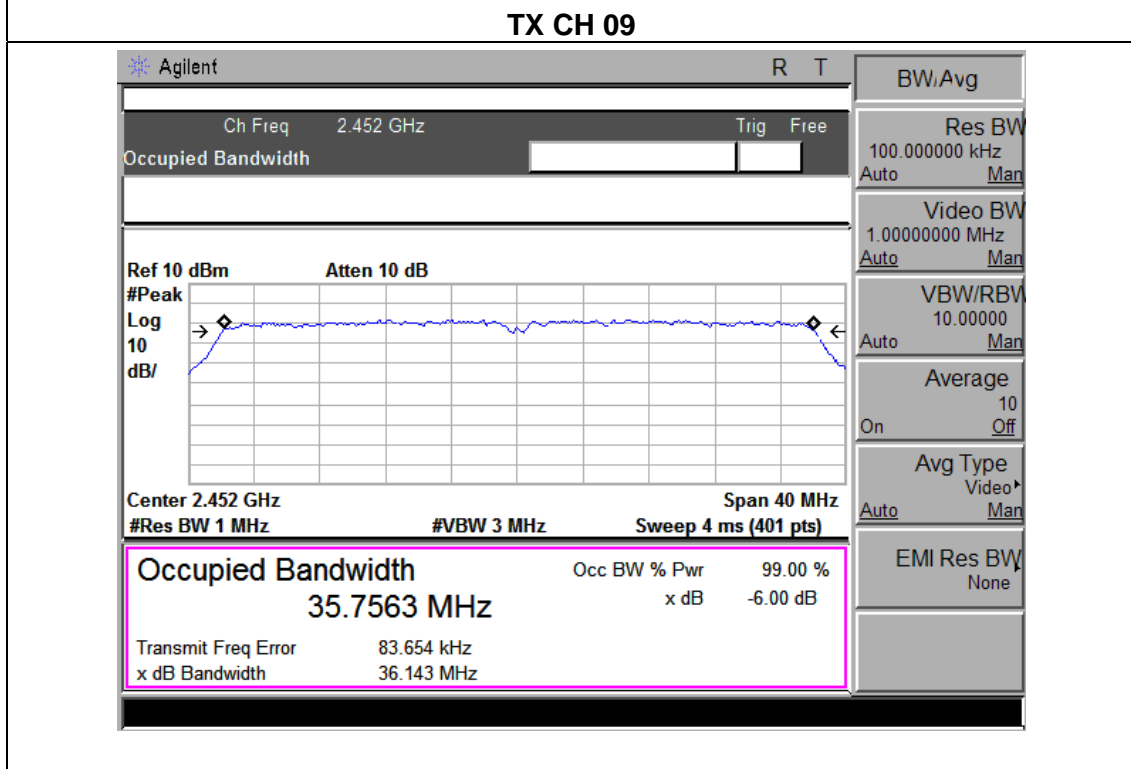
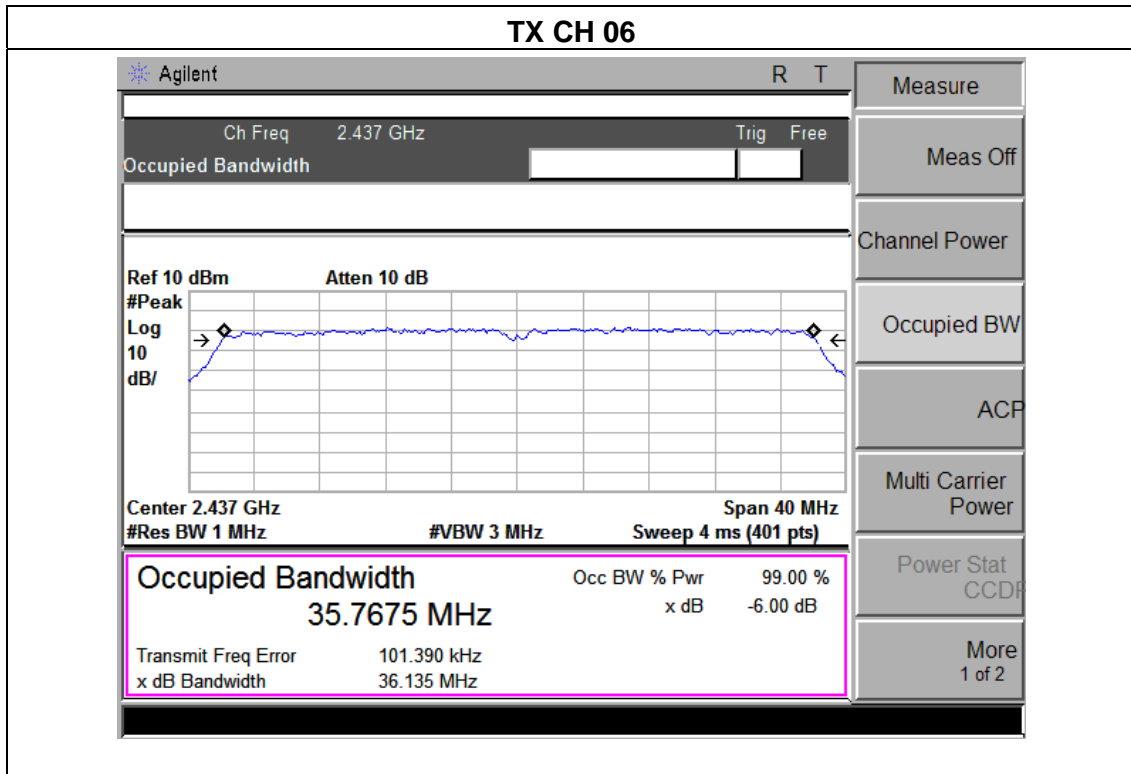

**6. PEAK OUTPUT POWER TEST**

**6.1 APPLIED PROCEDURES / LIMIT**

FCC Part15 (15.247) , Subpart C				
Section	Test Item	Limit	Frequency Range (MHz)	Result
15.247(b)(3)	Peak Output Power	1 watt or 30dBm	2400-2483.5	PASS

**6.1.1 TEST PROCEDURE**

- a. The EUT was directly connected to the Power meter

**6.1.2 DEVIATION FROM STANDARD**

No deviation.

**6.1.3 TEST SETUP**



**6.1.4 EUT OPERATION CONDITIONS**

The EUT tested system was configured as the statements of 2.4 Unless otherwise a special operating condition is specified in the follows during the testing.

**6.1.5 TEST RESULTS**

EUT :	MID	Model Name :	MID7326CM
Temperature :	25 °C	Relative Humidity :	60%
Pressure :	1012 hPa	Test Voltage :	DC 5V From Adapter AC 120V/60Hz
Test Mode :	TX b/g/n(20M,40M) Mode /CH01, CH06, CH11		

**TX 802.11b Mode**

Test Channe	Frequency	Peak output power.	Antenna Gain	EIRP	LIMIT
	(MHz)	(dBm)	dBi	dBm	dBm
CH01	2412	8.74	2.0	10.74	30
CH06	2437	9.10	2.0	11.10	30
CH11	2462	8.46	2.0	10.46	30

**TX 802.11g Mode**

CH01	2412	8.59	2.0	10.59	30
CH06	2437	8.28	2.0	10.28	30
CH11	2462	8.81	2.0	10.81	30

**TX 802.11n/20M Mode**

CH01	2412	8.79	2.0	10.79	30
CH06	2437	8.64	2.0	10.64	30
CH11	2462	9.27	2.0	11.27	30

**TX 802.11n/40M Mode**

CH03	2422	9.04	2.0	11.04	30
CH06	2437	7.93	2.0	9.93	30
CH11	2452	8.57	2.0	10.57	30

## **7. ANTENNA REQUIREMENT**

### **7.1 STANDARD REQUIREMENT**

15.203 requirement: For intentional device, according to 15.203: an intentional radiator shall be designed to ensure that no antenna other than that furnished by the responsible party shall be used with the device.

### **7.2 EUT ANTENNA**

The EUT antenna is Internal antenna. It comply with the standard requirement.

**8. EUT TEST PHOTO**

**Radiated Measurement Photos**

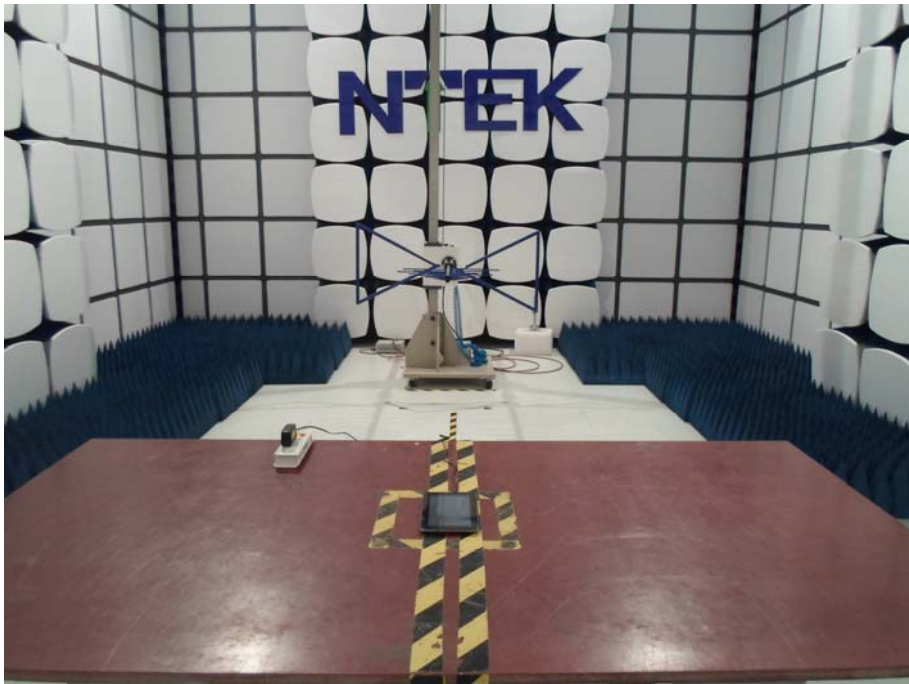
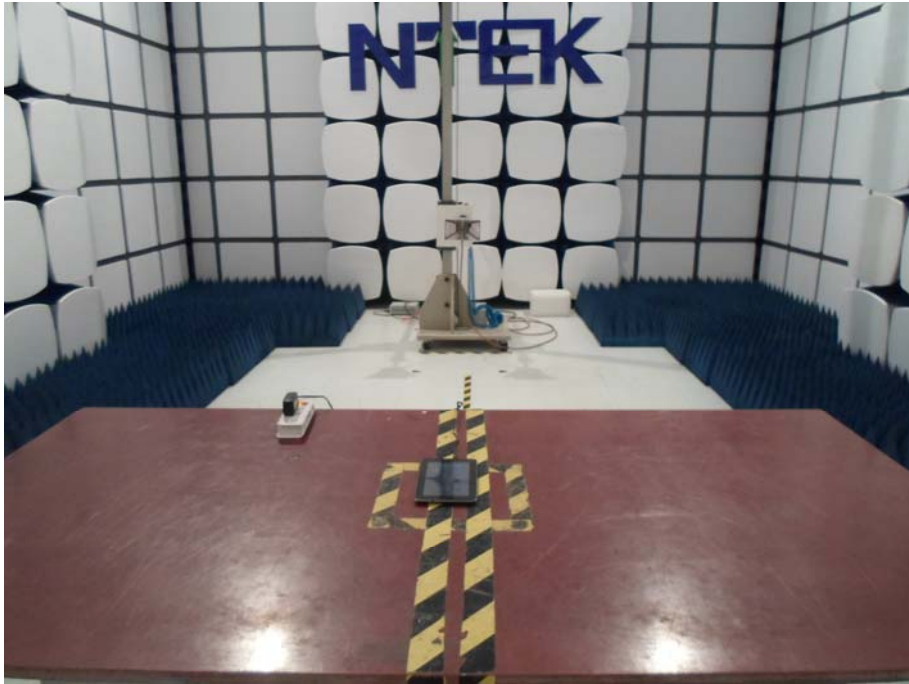

**Conducted Measurement Photos**

