

# 9" TABLET WITH INTEGRATED PORTABLE DVD PLAYER

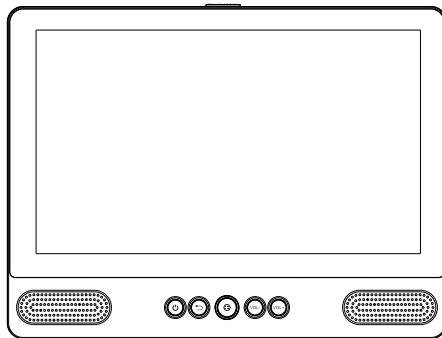

**USER MANUAL**

MD-92

# SAFETY WARNING

Before operating the unit, please read this manual thoroughly.

## Placement

- Do not place the product on an unstable cart, stand, tripod, bracket, table or shelf.
- Do not expose the product to direct sunlight and other sources of heat.
- Do not handle liquids near or on the product.
- Do not put the product near appliances that create magnetic fields.
- Do not put heavy objects on top the product.
- Do not use a microwave to dry the product.
- Do not let the product fall.

## Power Supply

- Check that products operating voltage is identical with the local 5V/2.5A power adaptor.
- Please unplug power supply and aerial plug when the weather is thunder storm or lightning.
- Please unplug power supply when there is nobody at home or didn't use over a long period of time.
- Please keep power cord from physical or mechanical damage.
- Please use original power supply.
- Fever after charging or long – time use is a normal phenomenon.

Remark: Units must be charged up 4 hours before use.

## Temperature

- Do not place the product near or over a radiator or a heater register.
- If your product is suddenly moved from a cold to a warm place, unplug the power cord for at least two hours so that moisture that may have formed inside the unit can dry completely.

## Humidity

- Do not expose machine to rain, damp or place near water.
- Ensure the indoor drying, cool.

## Ventilation

- Please use dry soft cloth to clean the product. Do not use alcohol to clean the product.

## Battery

- Please do not unplug the battery by yourself.
- Please do not charge the product for too long time.

## Storage

- To avoid damage to your Micro SD card/USB storage, please use setting/storage/ SD Card (USB storage) unmount storage before unplugging your Micro SD card or USB storage.

## Features

Browse the Web.  
Visit your favorite websites

Check your e-mail  
Keep in touch with friends and family

Watch YouTube™ videos  
Browse the world's most popular  
video-sharing community

Read your favorite books  
Download thousands of books .

Discover thousands of apps for Android™  
Games, applications, and more with  
play store(need for customer installed).

Connect to the Internet wirelessly  
High-speed Wi-Fi 802.11 b/g/n networking

Enjoy in the comfort of your living room

Enjoy your media library anywhere  
Portable powerhouse plays popular music,  
video, and photo formats  
microSD memory card reader  
Increase your storage capacity (up to 32 GB  
supported)

Automatic orientation detection  
Read any way you want; the display adjusts  
automatically!

Intergrated DVD player  
Compatible with DVD, DVD±RW, VCD, CD,  
CD-R/RW, MP3

## Unit at a Glance

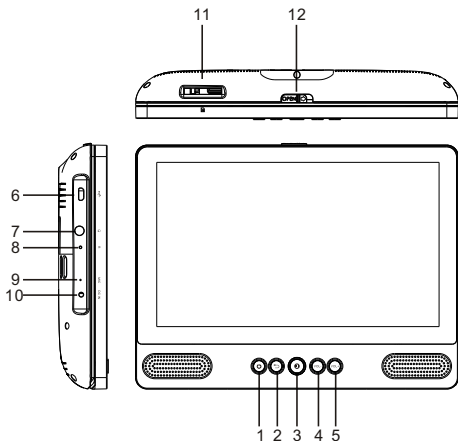

### 1. POWER

Press to turn the unit on or off, or to turn the screen on or off.

- To turn the unit on, press and hold the power button.
- To turn the unit off press and hold the power button to access the Power Off menu, then you can tap "Power off" to turn off the unit.

When in DVD mode, power button is unavailable to be used. pls return to the Tablet interface for powering off.

### 2. Return

Press this button return to the previous page.

### 3. Home

### 4. VOL-

Decreases the volume.

### 5. VOL+

Increase the volume.

### 6. USB HOST

Connect to a USB device or a computer to transfer data (e.g. music, videos, photos, files).

### 7. Headphone

Audio output connection for headphones.

### 8. RESET

Re-start and reset the unit

### 9. MIC

### 10. DC IN Socket

### 11. SD CARD

Insert external SD memory cards here.

### 12. OPEN Switch

Open the disc tray

## Getting Started

### Turning the Tablet on or off

To turn the tablet on:  
Press and hold the Power key until the LCD screen turns on. Wait until the home screen appears; the tablet is now ready for use.

To turn the tablet off:

1. Press and hold the Power key until the Device Options menu appears.

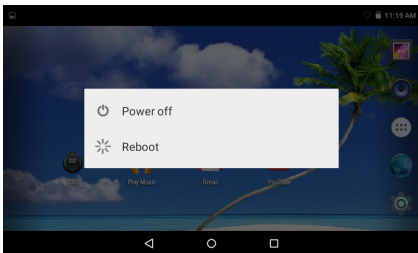

2. Touch ok the screen to turn off the tablet.

### Turning the Screen On or off (Standby)

When the tablet is on, you can turn off the screen to conserve battery power. Simply press the Power key once to turn the screen off. Press the Power key again to turn the screen back on.

**i** To conserve battery power, the screen can be set to turn off automatically when the tablet is not in use (between 1 minute and 30 minutes). This Screen timeout option can be found in the Display menu.

## Getting Started

### Unlocking the Screen

When the screen turns off, you will have to unlock the screen when you turn it back on.  
To unlock the screen, swipe up the lock icon.

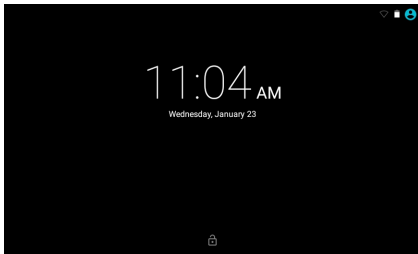

## About Applications

To open an application, touch the application icon on the home screen or in the Launcher where you can tap the icon right up on the home screen to get in..

Launcher screen:

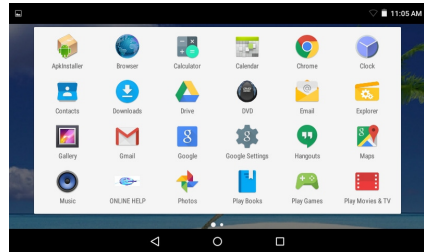

The screen shown above is for illustrative purposes only. Reserves the right to modify and improve the final list of applications available on the tablet.

## About Applications

### Preinstalled Applications

Some applications have been installed on your tablet for your convenience.

These applications include:



Browse the web.



Perform simple mathematical operations.



Check your e-mail.



Play music.



Access the Settings menu to adjust the tablet's options.



Access DVD mode

## Preinstalled Applications

### Installing Applications

You can also download and install additional applications from the device's applications marketplace, the web browser, or other sources.

The tablet must be set to allow installation of applications from non-Market sources. The Unknown sources option can be set in the Application settings menu.

## Connect to a Wi-Fi network

The Notification bar displays icons that indicate your tablet's Wi-Fi status.

 Notification that an open Wi-Fi network is in range.

 Connected to a Wi-Fi network (waves indicate connection strength).

[no icon] There are no Wi-Fi networks in range, or the Wi-Fi radio is off.

1. Turn on the Wi-Fi radio if it is not already on. To turn on Wi-Fi:
  - a. Go to the Home screen: Press the Home key.
  - b. Open the Settings menu: tap the icon right up on the home screen to get into the launcher, then touch Settings icon.
  - c. Open the Wireless & networks menu: Slide the icon to ON status.

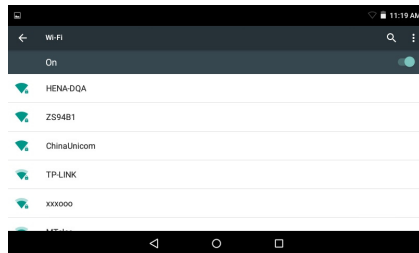

When Wi-Fi is on, the tablet will look for and display a list of available Wi-Fi networks.

 If a network that you have connected to previously is found, the tablet will connect to it. If you don't see your network in the list, you can force the tablet to re-scan. To scan for networks, tap the Menu key, and then touch Scan.



## Connect to a Wi-Fi network

### 2. Select an available Wi-Fi network to connect to:

In the same Wi-Fi settings menu above, touch a network in the list.

If the network is open, the tablet will prompt you to confirm connection to the network. Touch Connect to confirm.

If the network is secured (as indicated by a Lock icon), the tablet will prompt you to enter a password or other credentials. Touch the Wireless password box to show the on-screen keyboard and then use it to enter the password. Touch Connect to confirm.

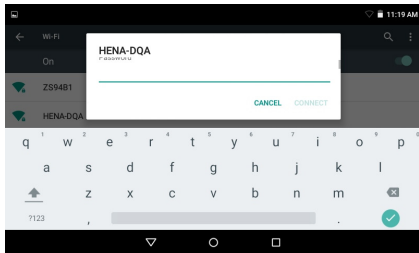

When you have successfully connected to a Wi-Fi network, the Notifications bar at the top of the screen will show a Wi-Fi signal indicator.



To learn about how to add a Wi-Fi network when it is not in range or when the router is set to obscure the network name (SSID); or to configure advanced Wi-Fi options, please refer to the manual.

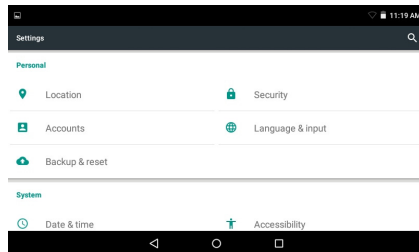

#### Note:

Reset function is only valid when the product in charging status. so pls connect the power adaptor when you want to Reset.

# Optional Connections

## Connecting to a Computer

Connect the tablet to a computer to transfer files.

### 1. Connect your tablet to the computer.

With the included USB cable: Plug the small end of the cable into the USB 2.0 high speed connector of the tablet. Plug the large end of the cable into an available USB 2.0 high speed port on the computer.

### 2. When your tablet is connected, slide up the USB icon right down on the screen and then touch icon USB connected.

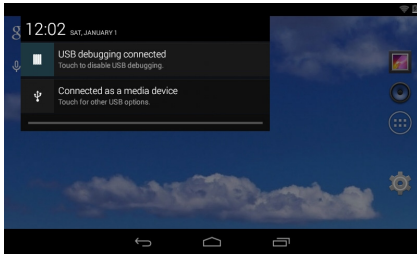

### 3. Mount the storage.

Touch button Turn on USB storage to mount the tablet's built-in storage. When it is mounted, you can copy files to or from your tablet.

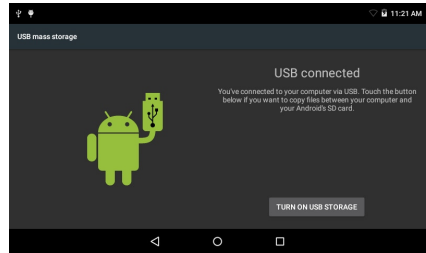

## DVD mode

Slide the **OPEN** switch to open the disc cover .  
Load the disc to the disc tray.  
Close the disc cover.  
Press the “⊕” to enter home screen,  
then tap DVD icon  to playback the disc.

During disc playback, 1--14 icons will appear.

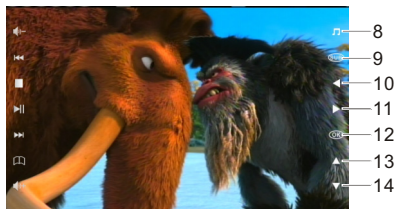

**1. VOL-**  
Decreases the volume.

**2. Move forward**  
Move forward next titles/chapters/tracks.

**3. ■ Stop**  
Stop playing a disc

**4. ⏮**  
Play or pause the disc playback

**5. Backward**  
Backward previous titles/chapters/tracks.

**6. Menu**  
Enter and exit the main DVD menu.

**7. VOL+**  
Increase the volume.

**8. Audio**  
Select one of the audio sound tracks on a DVD  
(if more than one is available) or select the audio  
output mode on a CD/MP3.

**9. Subtitle**  
Select a subtitle language programmed on a DVD  
(if available)

**10/11/13/14 Left/Right/Up/Down/ Cursor**  
Move between selections on a menu screen  
and adjust certain settings.

**12. OK**  
Confirm selections on a menu setting

# Specifications

## Tablet:

Processor	RK3128 Quad core 1.3GHz
RAM	1GB DDR3
Storage	8GB flash built-in; microSD card slot (max.32GB supported)
Display	9" TFT LCD (800X480), Capacitive touch screen
Wi-Fi Networking	IEEE 802.11 b/g/n
Audio Output	3.5mm headphone
PC Interface	USB 2.0 high speed
Additional Features	Built-in microphone 2x1W speaker
Decoding Format	DVD, DVD±RW, VCD, CD, CD-R/RW, MP3
Operating System	Android™ 5.1
Power	Mains adapter output: 5V=2.5A Rechargeable Li-poly battery
Playback Time (hours)	Up to 6 hours music, 2 hours video, 3 hours web browsing

## DVD:

Disc format	DVD, CD, CD-R, CD-RW, JPEG
Video System	PAL, NTSC
Operation Time	2 Hours fully charged
Battery Capacity	4000 mAh

\* On the mode of DVD playback,  
the unit does not support HDMI output

Features and specifications  
are subject to change without prior notice.

## FCC Warning

Any Changes or modifications not expressly approved by the party responsible for compliance could void the user's authority to operate the equipment.

This device complies with part 15 of the FCC Rules. Operation is subject to the following two conditions: (1) This device may not cause harmful interference, and (2) this device must accept any interference received, including interference that may cause undesired operation.

This equipment complies with FCC radiation exposure limits set forth for an uncontrolled environment.

This transmitter must not be co-located or operating in conjunction with any other antenna or transmitter.

Note: This equipment has been tested and found to comply with the limits for a Class B digital device, pursuant to part 15 of the FCC Rules. These limits are designed to provide reasonable protection against harmful interference in a residential installation. This equipment generates uses and can radiate radio frequency energy and, if not installed and used in accordance with the instructions, may cause harmful interference to radio communications. However, there is no guarantee that interference will not occur in a particular installation. If this equipment does cause harmful interference to radio or television reception, which can be determined by turning the equipment off and on, the user is encouraged to try to correct the interference by one or more of the following measures:

- Reorient or relocate the receiving antenna.
- Increase the separation between the equipment and receiver.
- Connect the equipment into an outlet on a circuit different from that to which the receiver is connected.
- Consult the dealer or an experienced radio/TV technician for help.