

MIPRO[®]

User Guide

TA-80

Digital Plug-on Transmitter

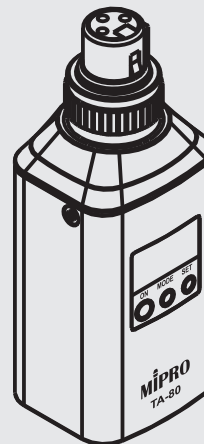

MIPRO[®]
MICROPHONE PROFESSIONALS

MIPRO Electronics Co., Ltd

Headquarters : 814 Pei-Kang Road, Chiayi, 60096, Taiwan
Tel : +886.5.238.0809 Fax : +886.5.238.0803
www.mipro.com.tw mipro@mipro.com.tw

All rights reserved. MN 016/11

Do not copy or forward without prior approvals MIPRO.

Specifications and design subject to change without notice.



2 CE547B

Contents

- 1 Transmitter Controls and Indicators
- 3 Operating Instructions
- 4 How to Setup Transmitter Parameters
- 14 Battery Status
- 17 MUTE (ON/OFF)
- 18 Insertion and replacing the batteries
- 19 MP-80 Battery Charger (Optional)
- 20 MP-20 Dual-Slot Battery Charger (Optional)

Transmitter Controls and Indicators

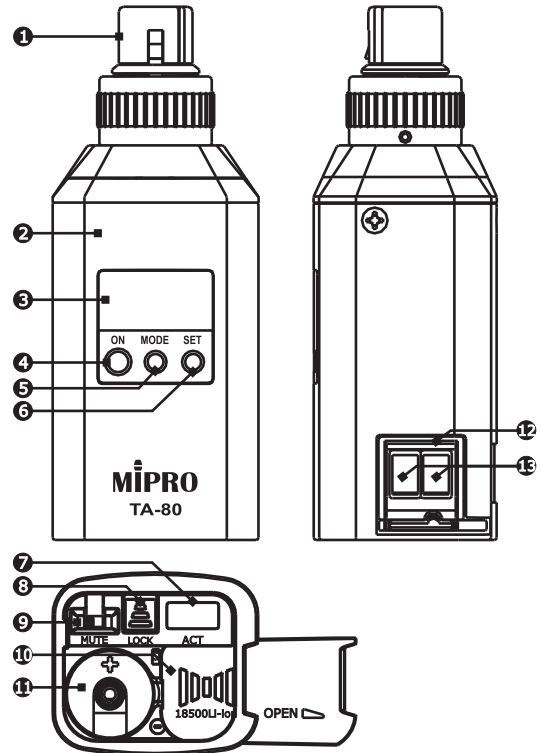

- ❶ **Microphone Input:** XLR-3 socket (female, balanced).
- ❷ **Housing:** Metal transmitter body.
- ❸ **LCD Panel:** Display transmitter parameters.
- ❹ **Power Button:** Press and hold 2 seconds to power ON or OFF.

- 5 **MODE Button:** Allows access to available functions displaying in LCD panel.
- 6 **SET Button:** Parameter selection button.
- 7 **ACT IR Port:** Align and syncs the transmitter and receiver frequency automatically.
- 8 **Battery cover lock:** Lockable battery cover.
- 9 **Mute Switch:** Muted (red light is on); Not muted (red light is off).
- 10 **Battery Cover:** Hinged cover opens to provide access to one 18500 rechargeable battery.
- 11 **Battery Compartment:** Accommodates one 18500 rechargeable battery.
- 12 **Charge Contacts Holder:** Fixed.
- 13 **Charge Contacts:** Align correctly to charge.

Operating Instructions

- Ascertain a wired microphone is plugged-in prior to power on the transmitter to prevent noise interference.
- Tighten the mechanical locking ring in a clockwise direction for a secured fit (see diagram 1).
- Unplug the microphone in a counter-clockwise direction.

Standard wired microphone XLR balanced output connector holder

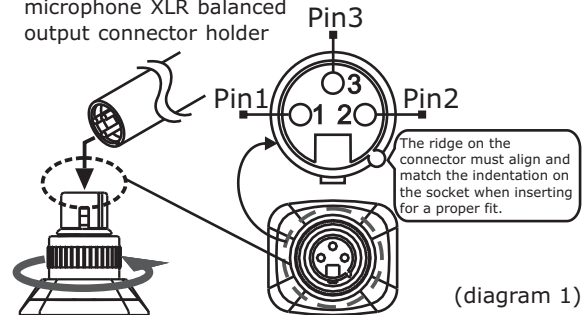

XLR balanced microphone connection pin name and function

- Pin 1:** Ground Pin (Negative phantom power)
- Pin 2:** AF+ (HOT) Positive phase input pin (String 6.8K Ω resistance to positive phantom power)
- Pin 3:** AF-(COOL) Negative phase input pin (String 6.8K Ω resistance to positive phantom power)

LCD Display Screen

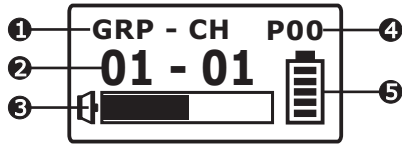

- ❶ LCD Screen
- ❷ Parameters Screen
- ❸ AF (audio) MUTE
- ❹ Phantom Power Status
- ❺ Transmitter Battery Meter

How to Setup Transmitter Parameters

- **MODE** Button:

Press "**MODE**" button to access one of the functions below.

- **SET** Button:

Press "**SET**" button and LCD will start flashing. During flashing, press SET button to change parameters.

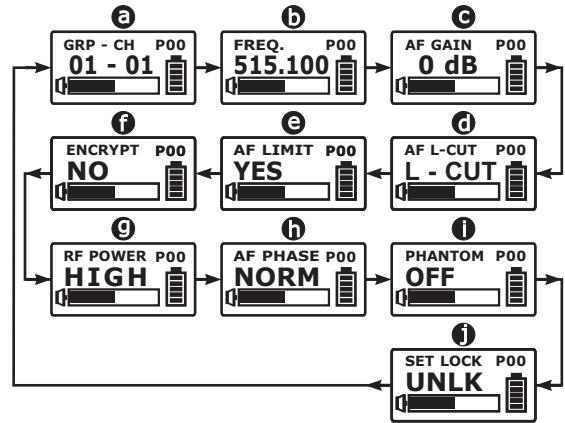
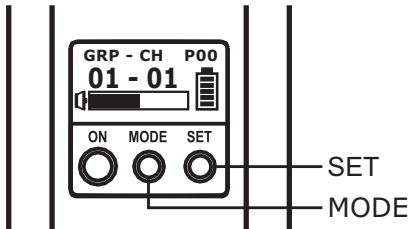

- ❶ Group and Channel
- ❷ Frequency
- ❸ Sensitivity Level
- ❹ AF Low Cut
- ❺ AF Limit
- ❻ Encryption
- ❼ RF Output Power
- ❽ AF Phase
- ❾ Phantom Power
- ❿ Parameters Lock & Unlock Status

GRP-CH: Displays Group and Channel Information

- a. Press MODE and stop on the **GRP-CH** function; the display showing the current group and channel will be flashing. After 30 seconds, the display will stop flashing and the current group and channel selection will be set.
- b. The group and channel information is now shown on the display. Changing the current group and channel must be done on the receiver.

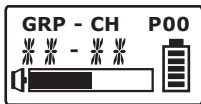

- c. Programming and saving Group and Channel need to be synced by pressing "ACT" button on the receiver.
- d. When programming a special frequency via monitoring software, the LCD screen cannot display the number. This is because this special channel is not in the preset group and channel. RF, the LCD panel will look like the illustration below.

**FREQUENCY:** Displays Transmitter Frequency Information

- a. Press MODE and stop on the **FREQUENCY** function; the display showing the current frequency will be flashing. After 30 seconds, the display will stop flashing.
- b. The frequency information is now shown on the display. Changing the current frequency must be done on the receiver.
- c. To modify the transmitter's group, channel and frequency, all three must be set at the receiver and the new setting transmitted to the transmitter via the ACT function.
- d. Programming and saving Frequency need to be synced by pressing "ACT" button on the receiver.

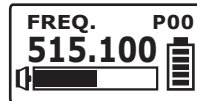

AF GAIN: Setup and Change of Input Sensitivity

- AF gain -18dB ~ 30dB in 6dB increment.
- Press MODE and stop on the **AF GAIN** function; the display showing the current status will be flashing and is ready to be modified.
- Press SET button to set dB value. -18dB ~ 30dB in 6dB increment
- Screen stops flashing and remains in the set state if not operated within 30 seconds.
- The higher the gains are set, the lower the dynamic range for signal input and the greater the danger of unwanted noises and feedback getting into the system.
- When using electronic guitar, gain should set at 0dB.
- Please make sure input signal strength does not exceed 2 Vrms (gain=6dB) as it is the maximum input strength allowed for transmitter without causing distortion.
- When the gain is set at -12dB or -18dB it stands up to 20Vp-p input signals. Signals cut off when it exceeds this level

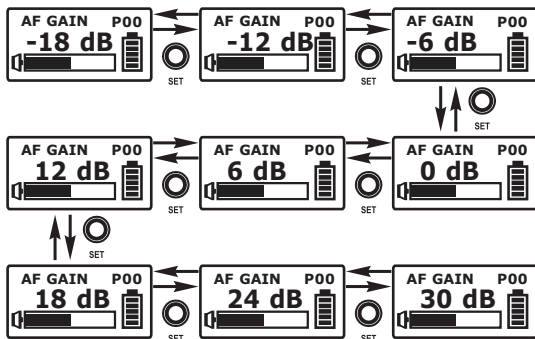
**AF L-CUT:** Setup and Change of Low Frequency Cut Off

- Press MODE and stop on the **AF L-CUT** function; the display showing the current status will be flashing and is ready to be modified.
- Press the SET button while the display is flashing to change to **L-CUT** or **FLAT** as desired.
- Screen stops flashing and remains in the set state if not operated within 30 seconds.
- When the AF L-CUT function is L-CUT, the frequency response below 100Hz will decrease about 3dB with a slope of -6dB/Octave.

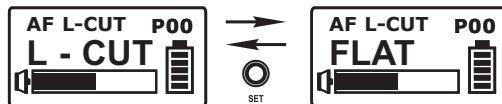
**AF LIMIT:** Setup and Change of Input Limit

- Press MODE and stop on the **AF LIMIT** function; the display showing the current status will be flashing and is ready to be modified.
- Press SET while the display is flashing to change the setting to YES or NO.
- Screen stops flashing and remains in the set state if not operated within 30 seconds.
- When the LIMIT is YES, the maximum output of the receiver is limited to 1V.

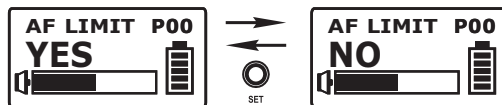

ENCRYPTION: Displays Information of Encryption

- Press MODE and stop on the **ENCRYPTION** function; the display showing the current status will be flashing.
- Screen stops flashing and remains in the set state if not operated within 30 seconds.
- The ENCRYPTION function displays status information only. Changing of the current status must be done from the receiver via the ACT function.
- The ENCRYPTION function must be set at receiver first then using ACT to program the transmitter.

**RF POWER:** RF Power Selection

- Press MODE button for selection of **RF POWER**. Selection of HIGH or LOW can be selected once the RF POWER LCD starts blinking.
- Press SET button to select and set HIGH or LOW.
- Screen stops flashing and remains in the set state if not operated within 30 seconds.
- HIGH has 50mW transmitting power. LOW has 10mW transmitting power. Set appropriate power to meet region/country regulations.

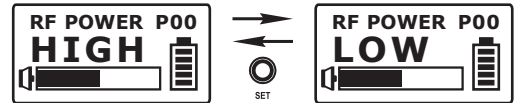

AF PHASE: Phase Selection of AF inputs

- Press MODE button for selection of **AF PHASE**. Selection of NORM or INVER can be selected once the AF PHASE LCD starts blinking.
- Press SET button to select and set NORM or INVER.
- NORM: AF input is positive (positive polarity)
INVER: AF input is negative (reverse polarity)
- Screen stops flashing and remains in the set state if not operated within 30 seconds.
- AF PHASE function provides users a phase selection for different condenser microphones. The normal setting is NORM, and INVER might be selected if two-wire condenser microphone is used.

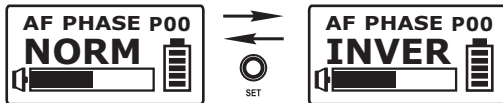
**PHANTOM:** Phantom Power

- Press the MODE button to select the **PHANTOM** screen, the LCD screen will start flashing in the current set state and is ready for change.
- Press the SET button to set OFF, 12V or 48V.
- The screen will stop flashing and remain in the set state if not operated within 30 seconds.
- PHANTOM is phantom power setting function, providing three selections: 12V or 48V or OFF, **12V** or **48V** is normally set for an external wired condenser microphone;
OFF is normally set for an external wired dynamic microphone.
- A general wired microphone with phantom power is allowed to use in 12V ~ 48V phantom power supply range. If it is determined that the phantom power wired microphone can operate at 12V, it is strongly recommended to be set to 12V, it reduces transmitter power consumption significantly & extends battery life.
- Phantom Power Status: P00 is turned off (OFF); P12 indicates 12V phantom power; P48 indicates 48V phantom power.
- Maximum power supply of 10mA up to 48V phantom power usage. However, observe the total power consumption will increase significantly and battery life will therefore be reduced by 50% or more.



SET LOCK: Setup and Change of Parameter Lock

- Press MODE button once for **SET LOCK** display. Once SET LOCK display starts blinking it is ready for selection.
- Press SET button for UNLK or LOCK selection.
- When locked (LOCK), receiver settings cannot be changed including the powering on & powering off. To power off it needs to be in unlock mode (UNLOCK).
- A sudden lose of power will deactivate the LOCK Function.

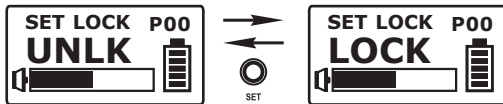
**Battery Status**

Indicates the power remaining in the transmitter battery. When the battery has less than 10% power remaining it must be replaced or recharged. If an under voltage condition continues, the LCD will show "OFF..." and the system will shut down to prevent being overly discharged.

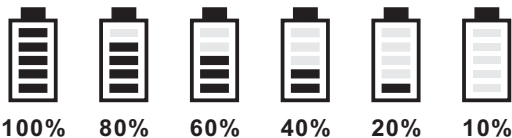
**"OFF..." : Power Off**

- Press and hold power button for 2 seconds to power on & off.
- When the power switch is turned off, the LCD will show "OFF..." (for Power Off) first and then the system will shut down and no further messages will be displayed.

ERR: Error Code

If the LCD displays "ERR" after turning on the power, it indicates the operation is not correct. The error codes are as follows:

ROM-ER → Transmitter does not have the initial data so the microphone is completely dead and cannot be programmed.

ERROR1 → Failure on RF circuitry, frequency cannot be programmed.



NO-03 → Frequency to be programmed into the transmitter exceeds the highest frequency of the designated frequency band of the transmitter.

NO-04 → Frequency to be programmed into the transmitter exceeds the lowest frequency of the designated frequency band of the transmitter.

****Note:**

NO-03 and NO-04 will not change the transmitter's original frequency and the transmitter will still operate normally with the error message on display. To remove the error message from the display panel, please switch off the transmitter and switch it on again.

MUTE (ON/OFF)

1.  Light on : "Muted".
2.  Light off : "Not Muted".
3. MUTE setting is not affected in LOCK mode.

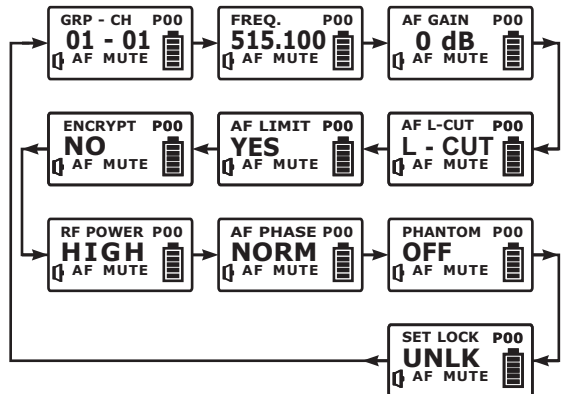
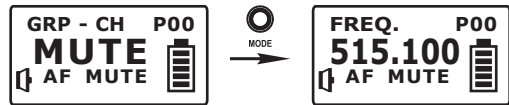
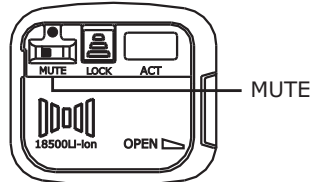

Insertion and replacing the batteries

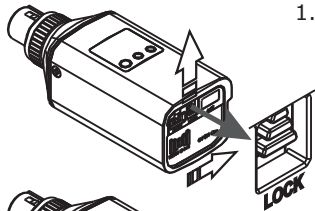

1. Push up the battery cover lock towards outward direction, and push the battery cover sideway to open.

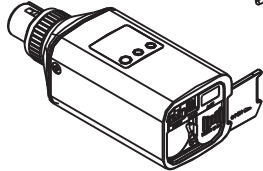

2. Ready for a 18500 rechargeable battery insertion or replacement.

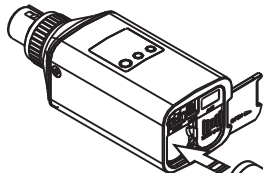

3. Insert one 18500 rechargeable battery as shown below with positive (+) end towards inside compartment.

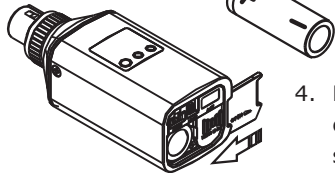

4. Push the battery cover back for a secured lock.

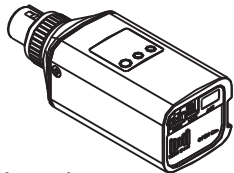

5. Make sure the battery cover is locked and tightly secured.

Attention:

Power off the transmitter to avoid additional battery use. Remove the battery if it will not be used for an extended periods of time.

MP-80 Battery Charger (Optional)

TA-80 transmitter and/or an additional 18500 recharge battery can be both recharged simultaneously in MP-80.

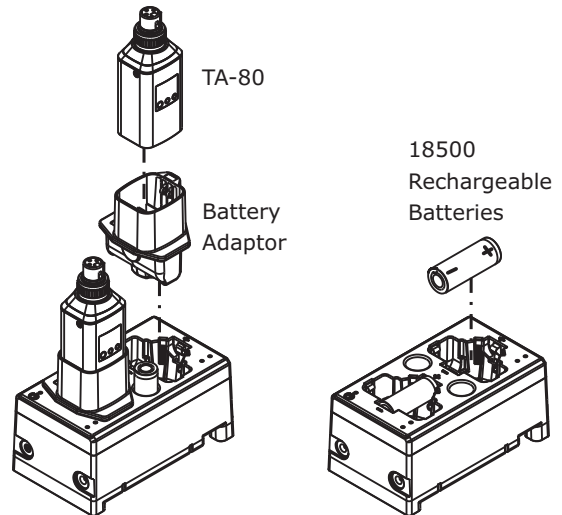

Insert the TA-80 into a supplied battery adaptor first before place into the MP-80 for charging.

Insert one or two 18500 rechargeable batteries into MP-80 according to the correct polarity.

MP-20 Dual-Slot Battery Charger (Optional)

Use the Battery Charger to charge up to two rechargeable 18500 Li-ion batteries for rechargeable MIPRO handheld or bodypack transmitter.

Charging Batteries: Insert the batteries with the correct positive (+) & negative (-) polarity and plug the charger into a power outlet, as shown here.

Charge Status: The indicator light displays the charging status of the batteries.

- Still Red: The batteries are charging.
- Still Green: The batteries are charged and ready to use.
- Flashing Light: May indicate any of the following conditions:
 - a. The batteries haven't been properly installed in the charger.
 - b. An unsupported type of battery is in the charger.
 - c. The batteries may be faulty or damaged and should be replaced.

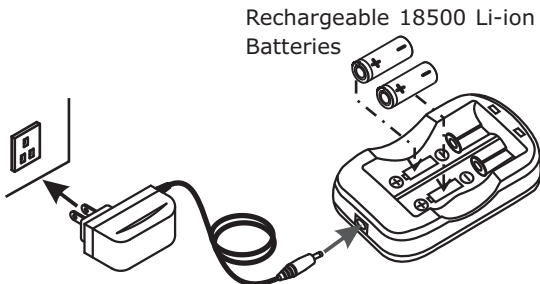

(Transformer is shown here for reference only)

FCC Statement

FCC Caution: To assure continued compliance, any changes or modifications not expressly approved by the party responsible for compliance could void the user's authority to operate this equipment. (Example - use only shielded interface cables when connecting to computer or peripheral devices).

THIS DEVICE COMPLIES WITH PART 74 OF THE FCC RULES. This equipment complies with FCC RF radiation exposure limits set forth for an uncontrolled environment.

Industry Canada Statement

This device complies with Industry Canada licence-exempt RSS standard.

Operation is subject to the following two conditions: (1) this device may not cause interference, and (2) this device must accept any interference, including interference that may cause undesired operation of the device.

Le présent appareil est conforme aux CNR d'Industrie Canada applicables aux appareils radio exempts de licence. L'exploitation est autorisée aux deux conditions suivantes : (1) l'appareil ne doit pas produire de brouillage, et (2) l'utilisateur de l'appareil doit accepter tout brouillage radioélectrique subi, même si le brouillage est susceptible d'en compromettre le fonctionnement.

WARNING**1. FOR OUTDOOR USE:**

To reduce the risk of fire or electric shock, do not expose this apparatus to rain or moisture.

2. UNDER WET LOCATION:

Apparatus should not be exposed to dripping or splashing and no objects filled with liquids, such as vases should be placed on the apparatus.

3. SERVICE INSTRUCTIONS:

CAUTION - These servicing instructions are for use by qualified service personnel only. To reduce the risk of electric shock, do not perform any servicing other than that contained in the operating instructions unless you are qualified to do so.



This symbol indicates that dangerous voltage constituting a risk of electric shock is present within this unit.



This symbol indicates that there are important operating and maintenance instructions in the literature accompanying this unit.

Disposal Dispose of any unusable devices or batteries responsibly and in accordance with any applicable regulations.



Disposing of used batteries with domestic waste is to be avoided!

2005-08-18

Batteries / NiCad cells often contain heavy metals such as cadmium(Cd), mercury(Hg) and lead(Pb) that makes them unsuitable for disposal with domestic waste. You may return spent batteries/accumulators free of charge to recycling centres or anywhere else batteries/accumulators are sold.

By doing so, you contribute to the conservation of our environment!

Notes

1. Refer to actual product in the event of product description discrepancy.
2. Frequency range and maximum deviation comply with the regulations of different countries.