

# MIPRO<sup>®</sup>

## User Guide

### GT-24 Guitar Transmitter

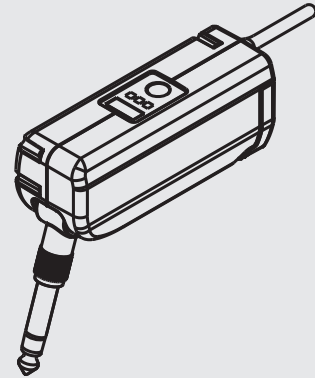

**MIPRO<sup>®</sup>**  
MICROPHONE PROFESSIONALS

**MIPRO Electronics Co., Ltd**

Headquarters : 814 Pei-Kang Road, Chiayi, 60096, Taiwan  
Tel : +886.5.238.0809 Fax : +886.5.238.0803  
www.mipro.com.tw mipro@mipro.com.tw

All rights reserved. MN 015/05

Do not copy or forward without prior approvals MIPRO.

Specifications and design subject to change without notice.



2 CE542A

## Contents

- 1 Transmitter Controls and Indicators
- 3 Operating Instructions
- 6 Battery Insertion
- 7 MP-80 Battery Charger (Optional)

## Transmitter Controls and Indicators

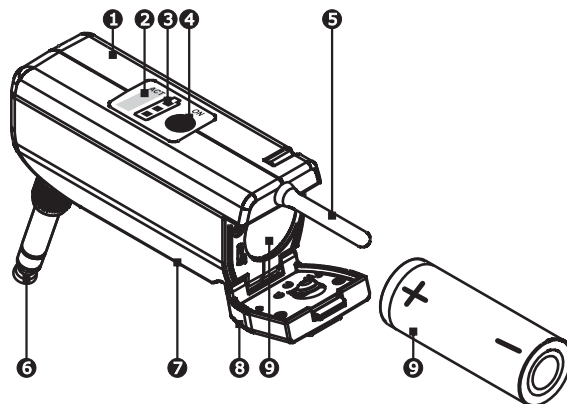

- ❶ **Housing:** Holds internal PCB.
- ❷ **ACT Port:** Align and sync frequency automatically with a matching receiver.
- ❸ **Battery Indicator Lights:** Shows the battery level or charging status.
- ❹ **Power:** Press and hold for 1~2 seconds to power on or off.
- ❺ **Antenna:**  $1/4 \lambda$  transmitting antenna.
- ❻ **6.3mm (1/4") phone jack plug:** Insert this adjustable plug into the electric guitar or electric bass.
- ❼ **Battery Charging Contact:** Align contacts during charging.
  - (a) Metal objects contact is forbidden.
  - (b) It is forbidden to contact metal objects.

- ⑧ **Battery Cover:** Holds a single 18500 rechargeable battery.
- ⑨ **Battery compartment & Battery:** Inserts a single 18500 rechargeable battery according to correct polarity. Insert with plus (+) polarity end of battery towards inside of the battery compartment(see above graph). Wrong polarity insertion will result in no connection and will not damage the circuitry.

## Operating Instructions

1. Power On & Off
  - a. Press & hold for 1~2 seconds.
  - b. Power On: battery indicator lights are lit solidly.
  - c. Power Off: battery indicator lights are not lit.
2. Battery Indicator Lights
  - a. Recommend to charge the battery when one single red indicator is solidly lit (25%) or replace with a fully-charged battery.



100%



75%



50%



25%

(green indicator)(red indicator)

3. Ensure both the receiver and guitar transmitter frequencies are synchronized to the same channel and power is off on the guitar transmitter before inserting the plug into the electric guitar. Power on and adjust audio levels after plug insertion.

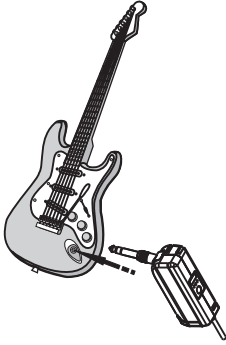

4. A suction cup holder can be installed manually for a secured fit for electric guitar/bass where the output jack is situated in different body area.

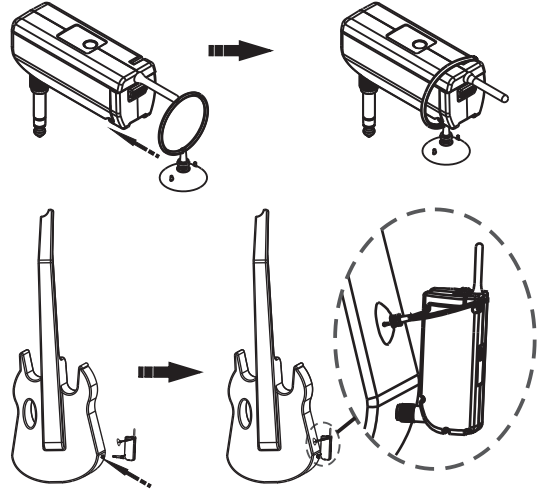

## Battery Insertion

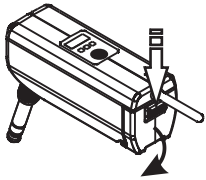

1. Gently push down on the battery compartment latch and swing the battery compartment door open (do not use force when opening or closing the battery door).

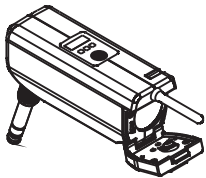

2. Install a freshly charged 18500 rechargeable battery with plus (+) polarity end of battery towards inside.

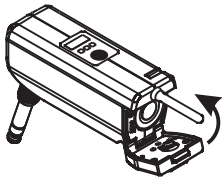

3. Then carefully close the battery door until the hinge is properly locked and secured.

## Caution

Remove the batteries if unused for a long period of time to prevent battery leakage, corrosion and causes possible damage to electronics.

## MP-80 Battery Charger (Optional)

GT-24 guitar transmitter and/or an additional 18500 recharge battery can be both recharged simultaneously in MP-80.

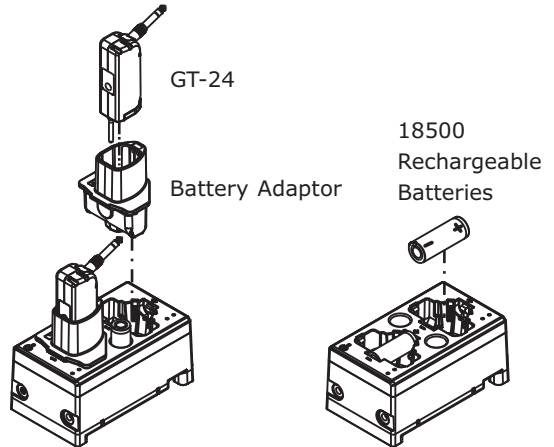

Insert the GT-24 into a supplied battery adaptor first before place into the MP-80 for charging.

Insert one or two 18500 rechargeable batteries into MP-80 according to the correct polarity.

## Notes

1. Refer to actual product in the event of product description discrepancy.
2. Frequency range and maximum deviation comply with the regulations of different countries.

## Federal Communication Commission Interference Statement

This equipment has been tested and found to comply with the limits for a Class B digital device, pursuant to Part 15 of the FCC Rules. These limits are designed to provide reasonable protection against harmful interference in a residential installation. This equipment generates, uses and can radiate radio frequency energy and, if not installed and used in accordance with the instructions, may cause harmful interference to radio communications. However, there is no guarantee that interference will not occur in a particular installation. If this equipment does cause harmful interference to radio or television reception, which can be determined by turning the equipment off and on, the user is encouraged to try to correct the interference by one of the following measures:

- Reorient or relocate the receiving antenna.
- Increase the separation between the equipment and receiver.
- Connect the equipment into an outlet on a circuit different from that to which the receiver is connected.
- Consult the dealer or an experienced radio/TV technician for help.

*FCC Caution:* To assure continued compliance, any changes or modifications not expressly approved by the party responsible for compliance could void the user's authority to operate this equipment. (Example - use only shielded interface cables when connecting to computer or peripheral devices).

### *FCC Radiation Exposure Statement*

This equipment complies with FCC RF radiation exposure limits set forth for an uncontrolled environment. This equipment should be installed and operated with a minimum distance of 0.5 cm between the radiator and your body.

This transmitter must not be co-located or operating in conjunction with any other antenna or transmitter.

The antennas used for this transmitter must be installed to provide a separation distance of at least 0.5 cm from all persons and must not be co-located or operating in conjunction with any other antenna or transmitter.

This device complies with Part 15 of the FCC Rules.

Operation is subject to the following two conditions:

- (1) This device may not cause harmful interference, and
- (2) This device must accept any interference received, including interference that may cause undesired operation.

## IC

This device complies with Industry Canada RSS-210 ISSUE 8 standards. Operation is subject to the following two conditions:

- (1) this device may not cause interference, and
- (2) this device must accept any interference, including interference that may cause undesired operation of the device.

Le présent appareil est conforme aux CNR d'Industrie Canada applicables aux appareils radio exempts de licence. L'exploitation est autorisée aux deux conditions suivantes:

- (1) l'appareil ne doit pas produire de brouillage, et
- (2) l'utilisateur de l'appareil doit accepter tout brouillage radioélectrique subi, même si le brouillage est susceptible d'en compromettre le fonctionnement.

**WARNING****1. FOR OUTDOOR USE:**

To reduce the risk of fire or electric shock, do not expose this apparatus to rain or moisture.

**2. UNDER WET LOCATION:**

Apparatus should not be exposed to dripping or splashing and no objects filled with liquids, such as vases should be placed on the apparatus.

**3. SERVICE INSTRUCTIONS:**

**CAUTION** - These servicing instructions are for use by qualified service personnel only. To reduce the risk of electric shock, do not perform any servicing other than that contained in the operating instructions unless you are qualified to do so.



This symbol indicates that dangerous voltage constituting a risk of electric shock is present within this unit.



This symbol indicates that there are important operating and maintenance instructions in the literature accompanying this unit.

**Disposal** Dispose of any unusable devices or batteries responsibly and in accordance with any applicable regulations.



Disposing of used batteries with domestic waste is to be avoided!

2005-08-18

Batteries / NiCad cells often contain heavy metals such as cadmium(Cd), mercury(Hg) and lead(Pb) that makes them unsuitable for disposal with domestic waste. You may return spent batteries/accumulators free of charge to recycling centres or anywhere else batteries/accumulators are sold.

By doing so, you contribute to the conservation of our environment!