

MP-8 LITHIUM-POLYMER BATTERY CHARGER

1. Part Names and Functions

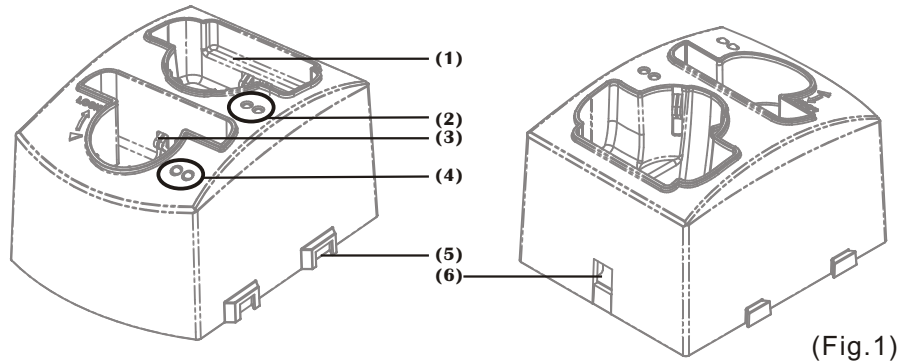

(Fig.1)

1. Microphone Charger: Accepts both handheld and body pack transmitters.
2. Microphone Charging Indicator:
 - (a) Red light flashing indicates battery is in the process of charging.
 - (b) Green light flashing indicates battery is fully charged (requires maximum of 4 hours).
3. Charger for Lithium-Polymer Battery: Accepts lithium-polymer battery module from handheld microphone as well as body pack transmitter.
4. Battery Module Charging Indicator:
 - (a) Red light flashing indicates battery is in the process of charging.
 - (B) Green light flashing indicates battery is fully charged (requires maximum of 4 hours).
5. Two chargers can be operated at the same time. This appears to require a cable to connect charger one to charger two using the same DC power supply. Is this correct and is this cable provided? What is the maximum # of chargers that can be connected together in this manner (to the same DC power supply)?
6. DC power supply input.



(Fig.2)

充發射器



(Fig.3)

充電池模組

MP-8 LITHIUM-POLYMER BATTERY CHARGER

2. Battery Charger Instructions:

1. Plug the provided DC power transformer into AC outlet and attach the battery charger as shown in diagram (4).
2. Insert the transmitter or battery module into the appropriate charging dock.

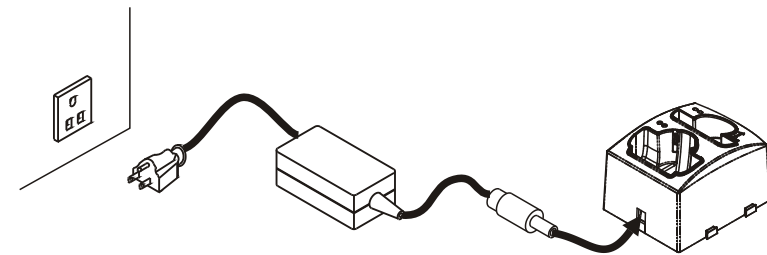

(Fig.4)

3. CAUTIONS:

If the voltage to the charger is too high, it will damage the charger, rechargeable battery and microphone at the same time. We recommend a 12V/1A DC power supply.

1. The transmitter must be switched off when it is charging.
2. Please do not use any other type of battery charger for safety reasons.
3. Please use only the specific type of transformer designed to work with the MIPRO charger to avoid voltage problems.

FCC ID: M5X-ACT8H

THIS DEVICE COMPLIES WITH PART 74 OF THE FCC RULES AND RSS-123 Issue1 OF CANADA.

OPERATION IS SUBJECT TO THE FOLLOWING TWO CONDITIONS:

- (1) This device may not cause interference.
- (2) This device must accept any interference, including interference that may cause undesired operation of the device.

This equipment complies with FCC RF radiation exposure limits set forth for an uncontrolled environment.