

Disposal

Dispose the unusable device according to valid regulations.

Disposal of spent batteries/accumulators

You are required by law to return all spent batteries. **Disposing of used batteries with domestic waste is prohibited!**



2005-08-13

Batteries / NiCad cells containing toxins are marked by accompanying symbols that refer to the prohibition of disposal with domestic waste. The designations for the decisive heavy metals are: **Cd**=cadmium, **Hg**=mercury, **Pb**=lead. You may return spent batteries/accumulators free of charge to the recycling centres, our outlets or anywhere else where batteries/accumulators are sold.

By doing so, you fulfil the legal requirements and contribute to the conservation of our environment!

MIPRO Electronics Co., Ltd.

Head office: 814, Pei-Kang Road, Chiayi, 60096, Taiwan.

Taipei office: 5, Lane 118, Sung-teh Road, 10075, Taipei, Taiwan.

Web-http: //www.mipro.com.tw

E-mail: mipro@mipro.com.tw

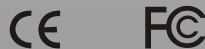

MIPRO

Digital Wireless Microphone Systems

Instruction Manual

ACT-8H : DIGITAL WIRELESS HANDHELD MICROPHONE

ACT-8T : DIGITAL WIRELESS BODY PACK TRANSMITTER



DIGITAL WIRELESS HANDHELD MICROPHONE

ACT-8H DIGITAL WIRELESS HANDHELD MICROPHONE



Main features:

1. The world's first 24-bit true digital handheld wireless microphone, combining the best design and the most advanced features.
2. Magnesium alloy housing offers a comfortable feel, balanced weight allocation and special surface finishing, giving it a truly professional appearance and quality.
3. Available in three colors: black, rose metallic and blue diamond. Custom-made colors are also available for special requirements.
4. Anti-roll & anti-pop microphone capsule module with extremely low touch noise characteristics.
5. Optional interchangeable microphone capsule modules.
6. Bright LCD display shows working channel, battery status, input level and error codes.
7. Integrated antenna provides maximum transmission efficiency and the patented color rear caps protect the on/off as well as the audio sensitivity switches while providing easy channel identification.
8. Built-in and detachable lithium-polymer (Li-Poly) battery pack can be recharged alone or together with the transmitter. Eight continuous hours of operation are possible due to its compact size and high-efficiency circuitry design.
9. Second generation of the world's first ACT function rapidly and precisely sets up the transmitter frequency.

DIGITAL WIRELESS HANDHELD MICROPHONE

1. Part Names and Functions

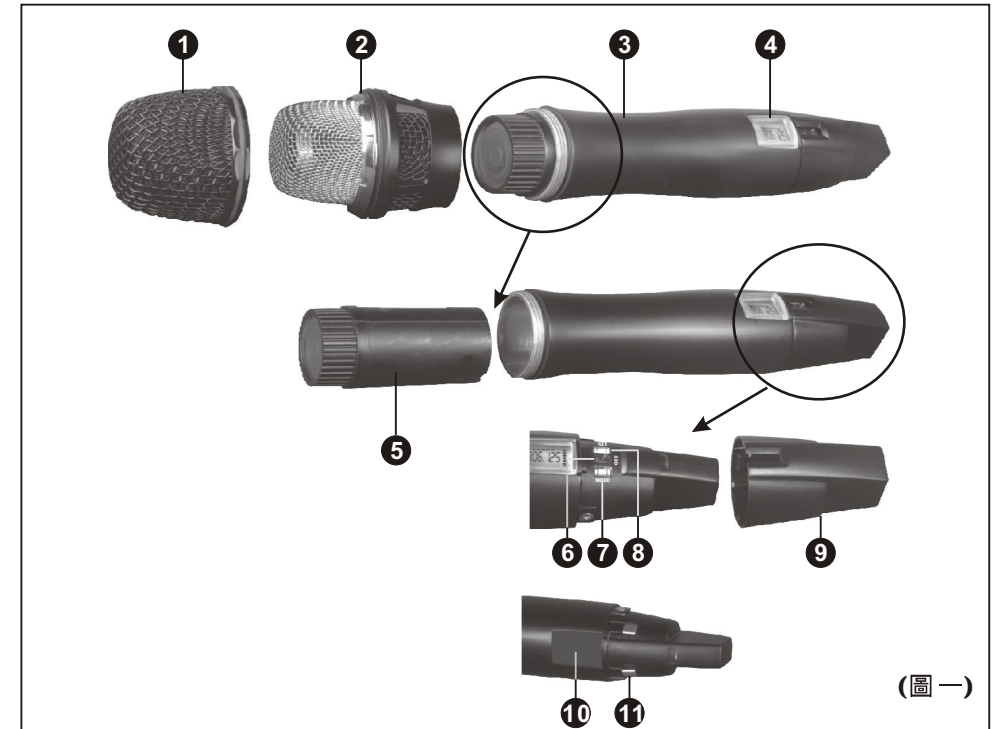

1. Upper Grille: Provides access & protection to capsule.
2. Capsule Module: Metal grille integrated to protect the capsule.
3. Housing: Houses various PCB and Li-Poly battery module.
4. LCD Display Panel: Displays group, frequency, gain, battery level, input SPL and error code.
5. Lithium-Polymer Battery Back: Built-in and detachable Li-Poly battery module can be recharged alone or together with transmitter; gives 8 hours continuous operation time.
6. Power Switch: Switch to "ON" when using microphone and "OFF" position when not.
7. MODE: Mode selection button.
8. SET: Parameter selection button.
9. Color Rear Cap: Designed to protect the ON/OFF switch to help prevent the user turning off the microphone during use.
10. ACT Receptor: Signal reception via the ACT function; automatically programs the frequency and the encryption code from the receiver.
11. Battery Charging Contact: For charging battery module.

DIGITAL WIRELESS HANDHELD MICROPHONE

2. Battery Removals and Installation

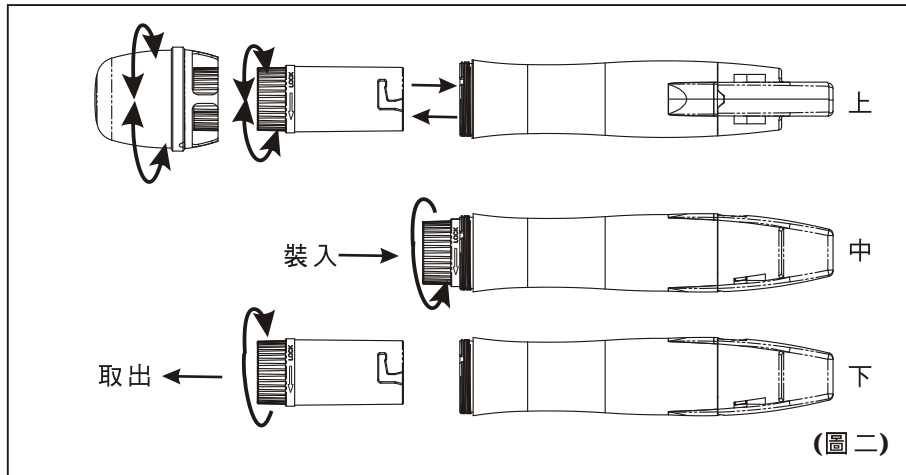

Open the upper grille and capsule module, then turning the battery pack in a counterclockwise direction in order to replace the battery (see diagram 2). To reinstall the battery module after loading the new battery, turn it in a clockwise direction (see diagram 2).

OPEN的字對準凹槽即可取出

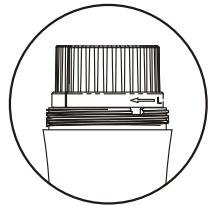

LOCK的字對準凹槽表示安裝成功

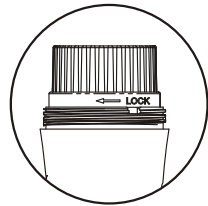

****NOTE: When microphone is not in use, please turn the power off. Battery pack can be recharged while in the transmitter or remove from transmitter and charged alone.**

DIGITAL WIRELESS HANDHELD MICROPHONE

3. Rear Cap On/Off Switch Protection

The patented color rear cap serves two purposes, provides easy channel identification and protecting the toggle on/off switch. It allows the on/off switch to either be exposed or concealed as desired. You can avoid unintended switching off of the microphone by rotating the color rear cap 180 degrees to cover the on/off switch completely.



****Note: When using the microphone, the color rear cap must be in place.**

4. LCD Panel Functions

Fully Lit VFD Display

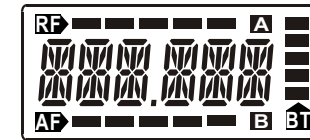

Function Selection:

Mode Switch: To select from different menu

The LCD panel has 6 functions displayed sequentially; their respective descriptions and operations are as follows:

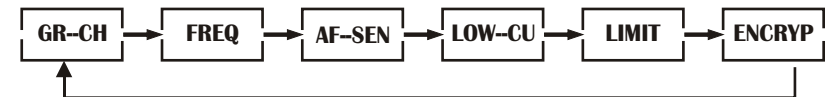

A. Operation Guide

- a. Press MODE (7) to access the 6 different functions. Once a function is selected, it starts flashing on the screen. If parameter needs to be modified on selected function, press SET (8) to modify the value while the display is still flashing. Once done, leave it for 5 seconds until it stops flashing and the selection will be programmed into the transmitter.

DIGITAL WIRELESS HANDHELD MICROPHONE

(1) GR-CH: Displays Information of Group and Channel

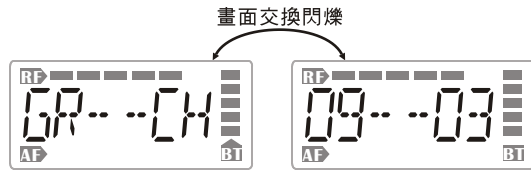

如在5秒中都沒被操作，畫面將停止閃爍。

A. Operate via MODE Button



B. Operation Guide:

- Press "MODE" and stop on "GR-CH" function, the display showing current group and channel will be flashing. After 5 seconds, the display will stop flashing.
- "GR-CH" function is added to display group and channel information. Changing current group and channel must be done on the receiver.

****NOTE: When program a special frequency via monitoring software; LCD screen cannot display the number. This is because this special channel is not in the preset group and channel. Therefore, LCD panel will look like illustration below.**

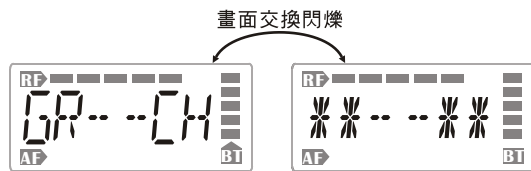

(2) FREQ: Displays Information of Transmitter Frequency

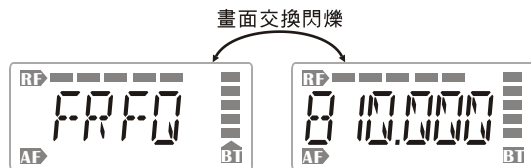

如在5秒中都沒被操作，畫面將停止閃爍，並停留在數字。此數字單位為"MHz"。

DIGITAL WIRELESS HANDHELD MICROPHONE

A. Operate via MODE Button

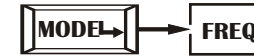

B. Operation Guide:

- Press "MODE" and stop on "FREQ" function, the display showing current frequency will be flashing. After 5 seconds, the display will stop flashing.
- "FREQ" function is added to display frequency information. Changing current frequency must be done on the receiver.

****NOTE: To modify transmitter's group, channel and frequency, all three must be set at the receiver and transmit the new setting to transmitter via ACT.**

(3) LOW-CU: Setup and Change of Low Frequency Cut Off



如在5秒中都沒被操作，畫面將停止閃爍。

A. Operate via MODE Button

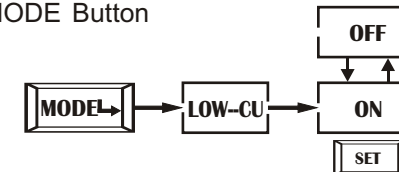

B. Operation Guide:

- Press "MODE" and stop on "LOW-CU" function, the display showing current state will be flashing and is ready to be modified.
- Press "SET" button to change to "ON" or "OFF" as desired.

****NOTE: When the LOW-CU function is "ON", the frequency response below 100Hz will decrease about 4dB with a slope of -6dB/Octave.**