



EMC Technologies (NZ) Ltd  
47 Mackelvie St, Grey Lynn  
Auckland 1021  
New Zealand  
Phone 09 360 0862  
Fax 09 360 0861  
E-Mail Address: aucklab@emctech.co.nz  
Web Site: www.emctech.co.nz

## **TEST REPORT**

**Gallagher C300400-T10 Mifare  
Proximity Card Reader**

*tested to the*

**47 Code of Federal Regulations**

**Part 15 - Radio Frequency Devices**

**Subpart C – Intentional Radiators**

**Section 15.225**

**Operation within the band 13.110 -14.010 MHz**

*for*

**Gallagher Group Ltd**

A handwritten signature in black ink, appearing to read "Andrew Cutler".

This test report is issued with the authority of:

\_\_\_\_\_  
**Andrew Cutler - General Manager**



All tests reported herein  
have been performed in  
accordance with the  
laboratory's scope of  
accreditation

## Table of Contents

<b>1. STATEMENT OF COMPLIANCE</b>	<b>3</b>
<b>2. RESULTS SUMMARY</b>	<b>3</b>
<b>3. INTRODUCTION</b>	<b>4</b>
<b>4. CLIENT INFORMATION</b>	<b>4</b>
<b>5. DESCRIPTION OF TEST SAMPLE</b>	<b>5</b>
<b>6. SETUPS AND PROCEDURES</b>	<b>7</b>
<b>7. TEST EQUIPMENT USED</b>	<b>27</b>
<b>8. ACCREDITATIONS</b>	<b>27</b>
<b>9. PHOTOGRAPHS</b>	<b>28</b>

## 1. STATEMENT OF COMPLIANCE

The **Gallagher C300400-T10 Mifare Proximity Card Reader** complies with FCC Part 15 Subpart C Section 15.225 as an Intentional Radiator when the methods as described in ANSI C63.10 - 2013 are applied.

## 2. RESULTS SUMMARY

The results from testing carried out in between the 14<sup>th</sup> November 2022 and 23<sup>rd</sup> November 2022 are detailed in the following table:

Clause	Parameter	Result
15.201	Equipment authorisation requirement	Certification required.
15.203	Antenna requirement	Complies. Antenna internal to the device.
15.204	External PA and antenna modifications	Not applicable. No external devices.
15.205	Restricted bands of operation	Complies. Device transmits on 13.560 MHz.
15.207	Conducted limits	Complies.
15.209	Radiated emission limits - Emissions < 30 MHz	Complies.
15.209	Radiated emission limits – Emissions > 30 MHz	Complies.
15.225	Radiated emission limits - Fundamental	Complies.
15.225	Frequency stability	Complies.

### 3. INTRODUCTION

This report describes the tests and measurements performed for the purpose of determining compliance with the specification.

**The client selected the test sample.**

**This report relates only to the sample tested.**

**This report contains no erasures**

**This report contains no corrections.**

Measurement uncertainties with statistical confidence intervals of 95% are shown below test results. Both Class A and Class B uncertainties have been accounted for, as well as influence uncertainties where appropriate.

All compliance statements have been made with respect of the specification limit with no reference to the measurement uncertainty.

All testing was carried out as per the standard in the worst-case configuration with no deviations being applied.

### 4. CLIENT INFORMATION

**Company Name** Gallagher Group Ltd

**Address** 181 Kahikatea Drive  
Melville

**City** Hamilton 3206

**Country** New Zealand

**Contact** Menardo Lazaro

## 5. DESCRIPTION OF TEST SAMPLE

<b>Brand Name</b>	Gallagher
<b>Model Number</b>	C300400-T10 Mifare
<b>Product</b>	Proximity Card Reader
<b>Manufacturer</b>	Gallagher Group Ltd
<b>Country of Origin</b>	New Zealand
<b>Serial Number</b>	2243405032
<b>FCC ID</b>	M5VC30040XB
<b>IC ID</b>	7369A-C30020XB
<b>Antenna</b>	Internal to product
<b>Highest oscillator frequency</b>	27.12 MHz
<b>Bluetooth facility</b>	Not Available in the product
<b>Operating frequency</b>	13.56 MHz NFC

### Product Description:

The device tested is a RFID card reader that operates on 13.560 MHz that would typically be used to allow security access to buildings and locations.

The product under test is powered at 13.6 Vdc which was supplied using a Gallagher 6000 HS controller that was in turn powered from a 120 Vac to 13.6 Vdc representative power supply.

The controller in turn was powered from a AC to DC convertor pictured in figure-3.

For radiated emissions test, a long length (>10 m) orange HBUS cable was used to route DC and control signals from FT controller to the EUT, to facilitate increased physical distancing between the EUT and ancillaries. The connections to the product from ancillaries have been represented in figure-1, 2 & 3.

When installed in the user locations the Device under test (DUT) would be typically powered by a 13.6 Vdc PSU.

**Figure-1: Block Diagram of product with Ancillaries**

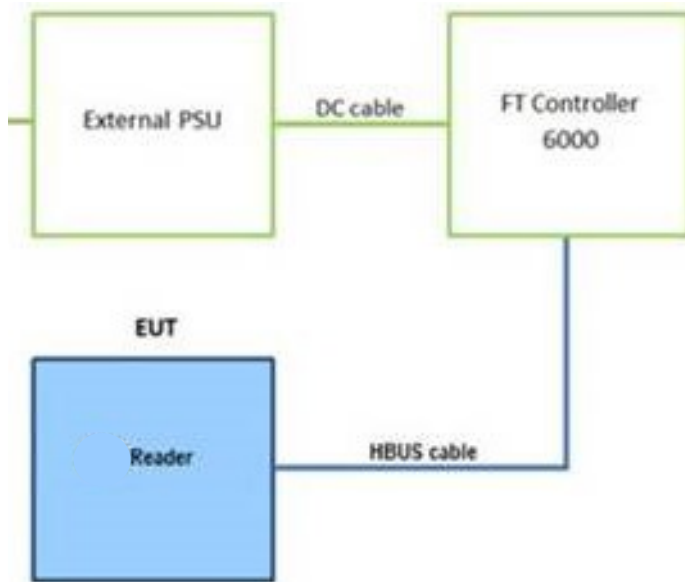

**Figure-2: Gallagher supplied controller (Ancillary)**



Gallagher controller 6000 (HS) has been supplied by the client to assist in the testing of DUT.

The controller gets powered at 13.6 Vdc using client supplied AC to DC convertor (as shown in figure 3).

RS485 port connects this controller to the DUT



Figure-3: AC to DC convertor (Ancillary)



Product dimensions and representative photo: 115 x 35 x 12 mm



## 6. SETUPS AND PROCEDURES

### Standard

The sample was tested in accordance with 47 CFR Part 15 Subpart C.

### Methods and Procedures

The measurement methods and procedures as described in ANSI C63.10 - 2013 were used.

#### Section 15.201: Equipment authorisation requirement

Certification as detailed in Subpart J of Part 2 is required for this device.

#### Section 15.203: Antenna requirement

The device has a permanently attached internal 13.560 MHz antenna.

**Result:** Complies.

#### Section 15.204: External radio frequency power amplifiers and antenna modifications

It is NOT possible to attach an external power amplifier to this transmitter.

**Result:** Complies.



## Section 15.205: Restricted bands of operation

The 13.560 MHz device will fall into the band of 13.110 – 14.010 MHz that is covered by Section 15.225.

Measurements were made using a spectrum analyser with the 99% power points being determined.

Measurements were made using a span of 1.0 MHz with a resolution bandwidth of 10 kHz and a video bandwidth of 30 kHz.

A worst case modulation bandwidth of 505.0 kHz was measured.

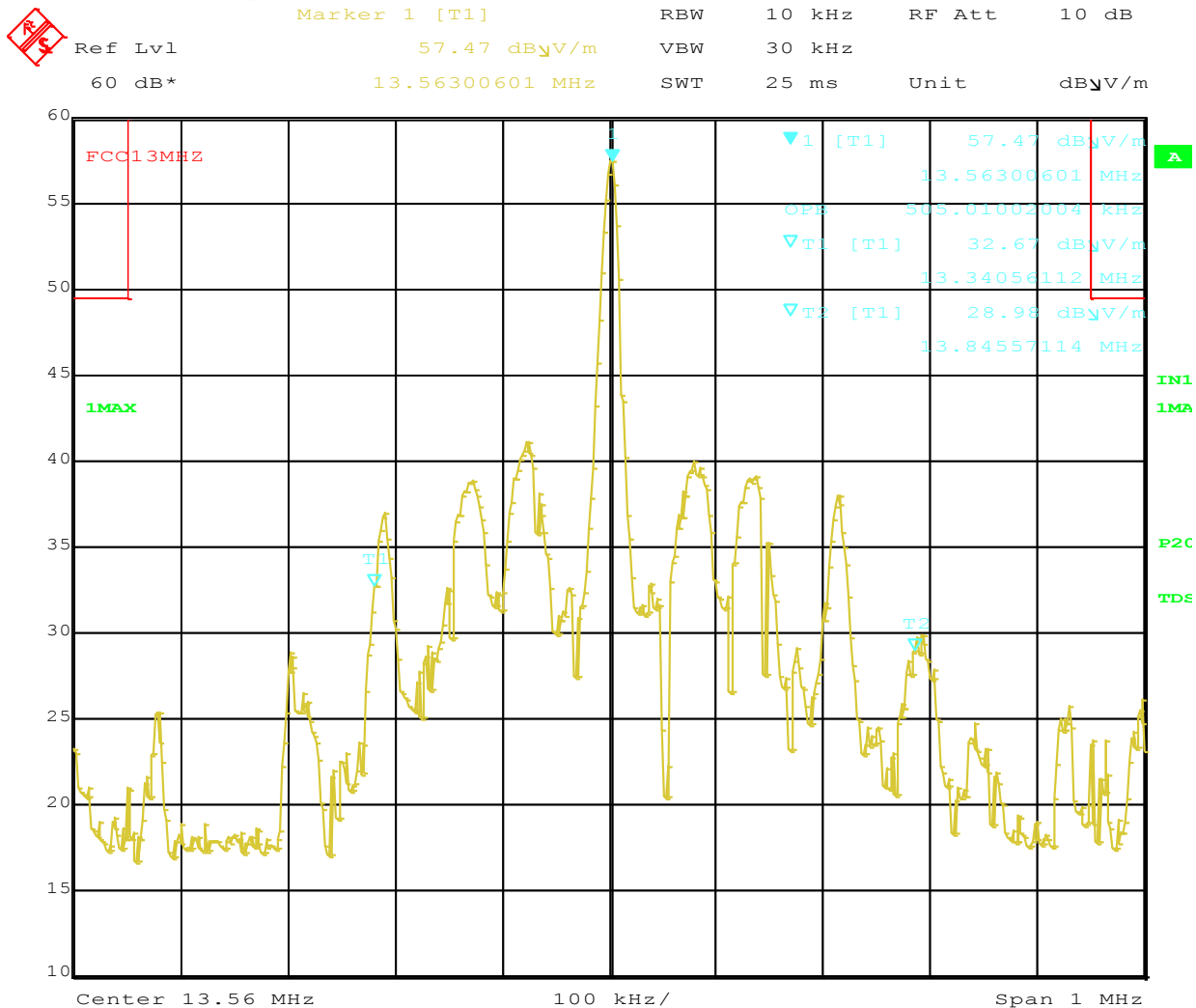

Date: 18.NOV.2022 13:22:19

**Result: Complies.**

## Section 15.207: Conducted emissions testing

Conducted Emissions testing was carried out over the frequency range of 150 kHz to 30 MHz which was carried out at the laboratory's MacKelvie Street premises in a 2.4 m x 2.4 m x 2.4 m screened room

As it is possible for this device to be directly or indirectly connected to the Public AC mains supply testing was carried out using a representative AC power supply system that was powered at 120 Vac 60 Hz which supplied 13.6 Vdc to the device under test via a Gallagher 6000 Controller Module.

The Device under test (DUT) operates on 13.560 MHz.

Initial testing was carried out when the DUT was operating normally with the internal antenna connected.

A second test was then carried out with the internal antenna in the DUT being replaced with a resistive dummy load.

The device is deemed to comply providing if the dummy load test complies and the overall emission signature for the product remains similar in both test configurations with no additional emissions being detected.

The device was placed on top of the emissions table, which is 0.8 m x 0.8 m, 80 cm above the screened room floor which acts as the horizontal ground plane.

In addition the device was positioned 40 cm away from the screened room wall which acts as the vertical ground plane.

The artificial mains network was bonded to the screened room floor.

At all times the device was kept more than 80 cm from the artificial mains network.

The supplied plot is combined plot showing the worst case quasi peak and average results of both the phase and neutral lines to the representative AC power supply.

Quasi peak and average detectors have been used with resolution bandwidths of 9 kHz.

**Result:** Complies

Measurement uncertainty with a confidence interval of 95% is:

- AC Mains port                       $(0.15-30 \text{ MHz}) \pm 2.8 \text{ dB}$



### Block Diagram showing the conducted emission test setup

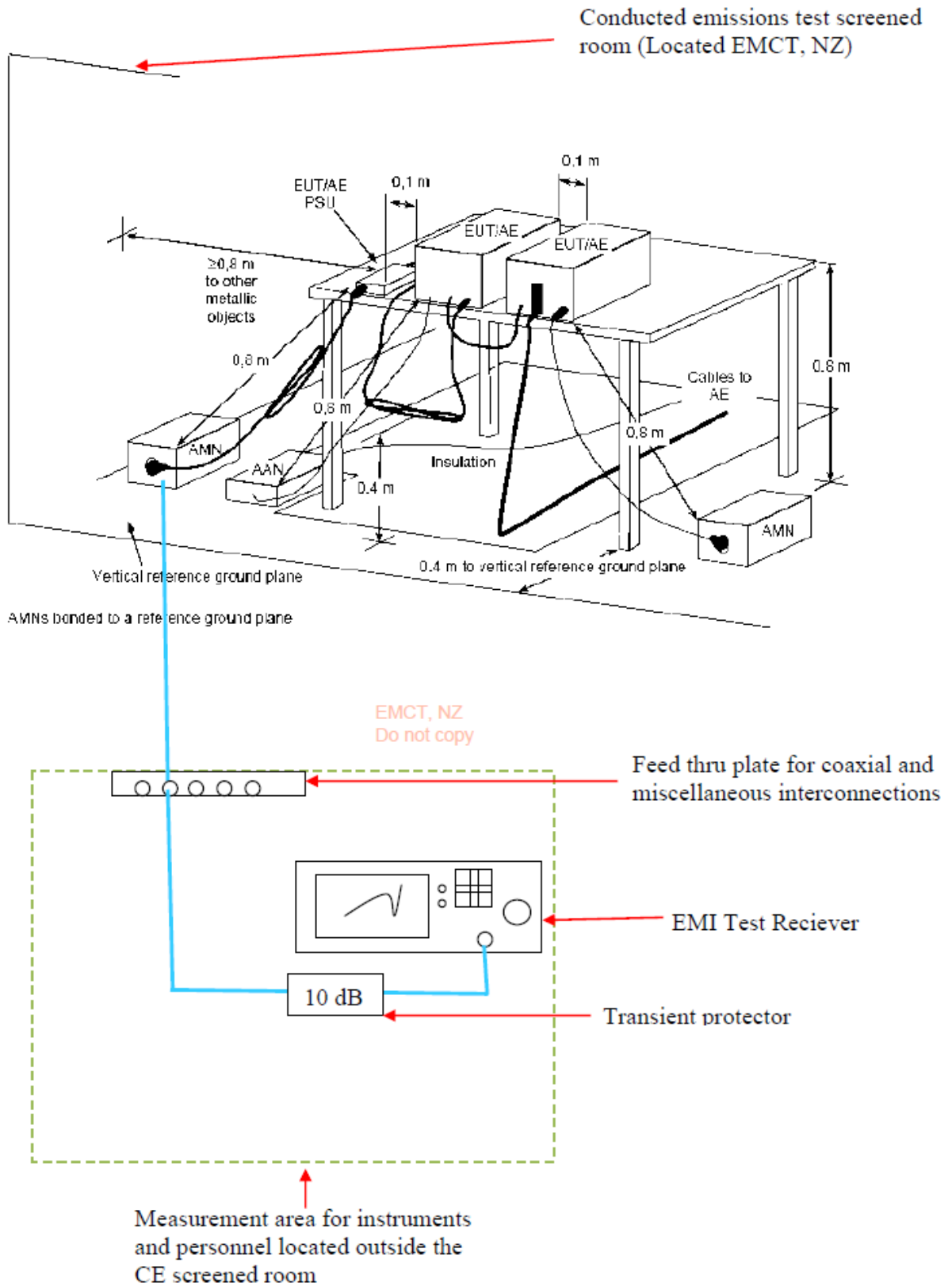

EMI Receiver Used: ESHS 10

## Conducted Emissions – AC Input Power Port

**Setup:** Gallagher T-10 with active NFC at 13.56 MHz. The testing was carried out with client supplied power supply connected to 120 VAC, 60 Hz power supply.

Peak --- Average -- Quasi Peak X Average +

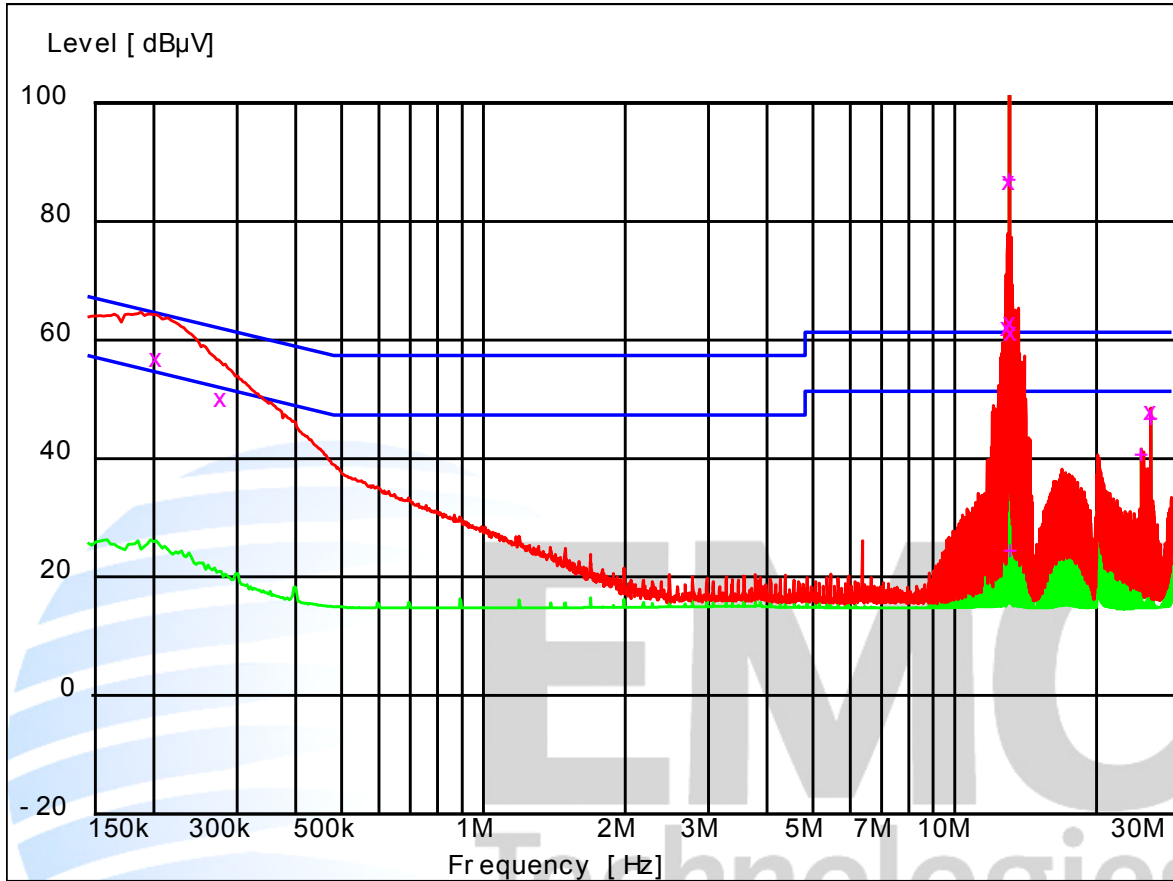

### Final Quasi-Peak Measurements

Frequency (MHz)	Level (dBµV)	Limit (dBµV)	Margin (dB)	Phase	Rechecks (dBµV)
0.210000	55.6	63.2	7.6	N	
0.288000	48.8	60.5	11.7	L1	
13.479500	60.9	60.0	-0.9	L1	<i>Fundamental</i>
13.560500	85.4	60.0	-25.4	N	<i>Fundamental</i>
13.641500	61.6	60.0	-1.6	N	<i>Fundamental</i>
13.695500	60.0	60.0	0.0	N	<i>Fundamental</i>
27.119000	46.6	60.0	13.4	N	

### Final Average Measurements

Frequency (MHz)	Level (dBµV)	Limit (dBµV)	Margin (dB)	Phase	Rechecks (dBµV)
13.560500	85.5	50.0	-35.5	N	<i>Fundamental</i>
13.641500	23.1	50.0	27.0	N	
25.895000	39.2	50.0	10.9	N	
27.119000	45.4	50.0	4.6	N	

## Conducted Emissions – AC Input Power Port

**Setup:** Gallagher T-10, Dummy load. The testing was carried out with client supplied power supply connected to 120 VAC, 60 Hz power supply.

Peak ---  
 Average --  
 Quasi Peak X  
 Average +

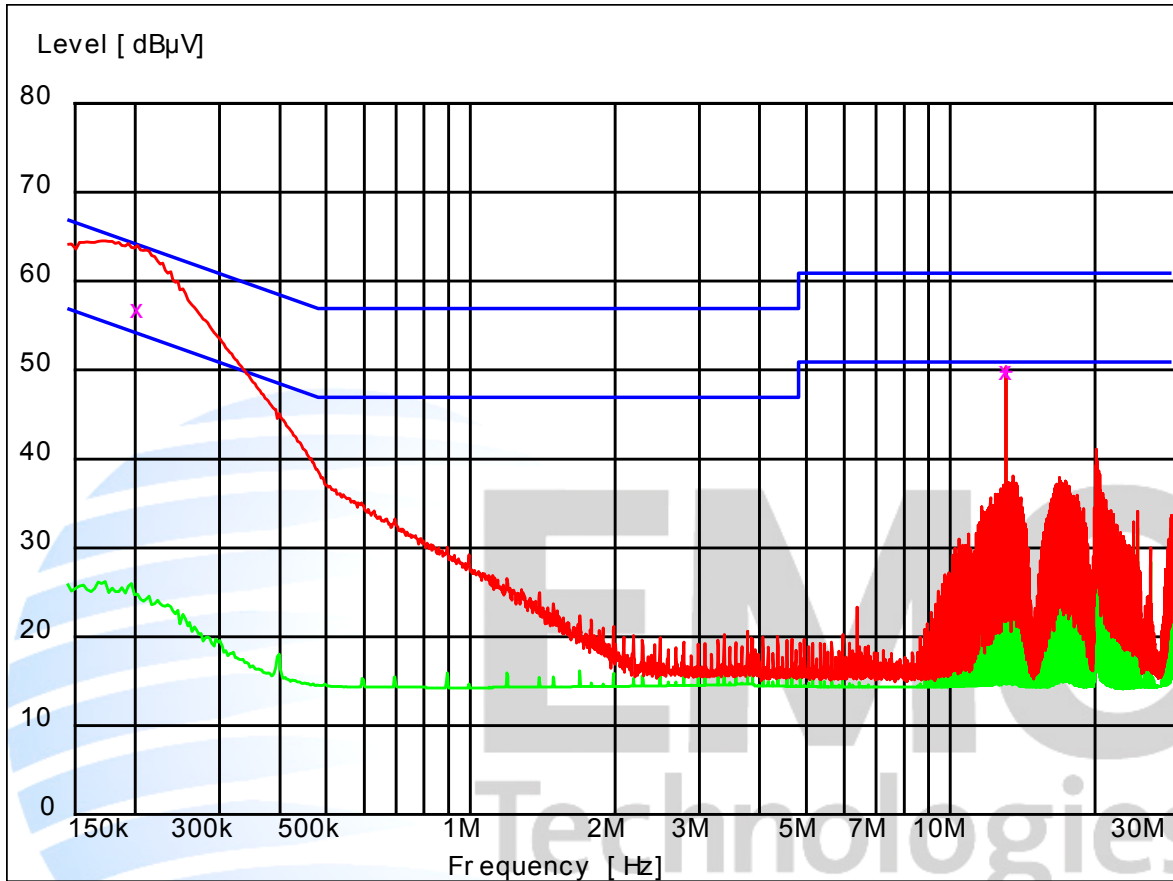

### Final Quasi-Peak Measurements

Frequency (MHz)	Level (dBµV)	Limit (dBµV)	Margin (dB)	Phase	Rechecks (dBµV)
0.210000	55.9	63.2	7.3	N	
13.560500	49.0	60.0	11.0	N	

### Final Average Measurements

Frequency (MHz)	Level (dBµV)	Limit (dBµV)	Margin (dB)	Phase	Rechecks (dBµV)
13.560500	48.9	50.0	1.1	N	49.0



## Section 15.209: Radiated emission limits, general requirements

Radiated emission testing was carried out over the frequency range of 10 kHz to 1000 MHz as the device contains a 13.560 MHz NFC transceiver and a digital device that has a highest frequency in use that is less than 108 MHz.

Testing was carried out at the laboratory's open area test site - located at Driving Creek, Orere Point, Auckland, New Zealand.

Testing was carried out using a representative AC power supply at 120 Vac 60 Hz that supplied 13.6 Vdc to a Gallagher 6000 Controller Module that in turn powered the device under test which were located directly behind the turntable on the test pad.

The device was observed transmitting continuously on 13.560 MHz.

Attached to the reader was a single 4 wire cable of 10 metre length of RS485 cable that was lead directly which enables the DC supply voltage and RS-485 communications between the device and controller.

When an emission is located, it is positively identified and its maximum level is found by rotating the automated turntable, and by varying the antenna height, where appropriate, with an automated antenna tower.

Below 30 MHz a magnetic loop is used with the centre of the loop being 1 metre above the ground with measurements being made using a quasi peak detector at a distance of 10 metres.

Above 30 MHz the emission is measured in both vertical and horizontal antenna polarisations at a distance of 3 metres.

Below 1000 MHz a Quasi Peak detector with a 120 kHz bandwidth is used.

The emission level was determined in field strength by taking the following into consideration:

Level (dB $\mu$ V/m) = Receiver Reading (dB $\mu$ V) + Antenna Factor (dB/m) + Coax Loss (dB)

For example, if an emission of 30 dB $\mu$ V was observed at 30 MHz.

$$45.5 \text{ dB}\mu\text{V/m} = 30.0 \text{ dB}\mu\text{V} + 14 \text{ dB/m} + 1.5 \text{ dB}$$



## Radiated Emissions Test setup at Open area test site

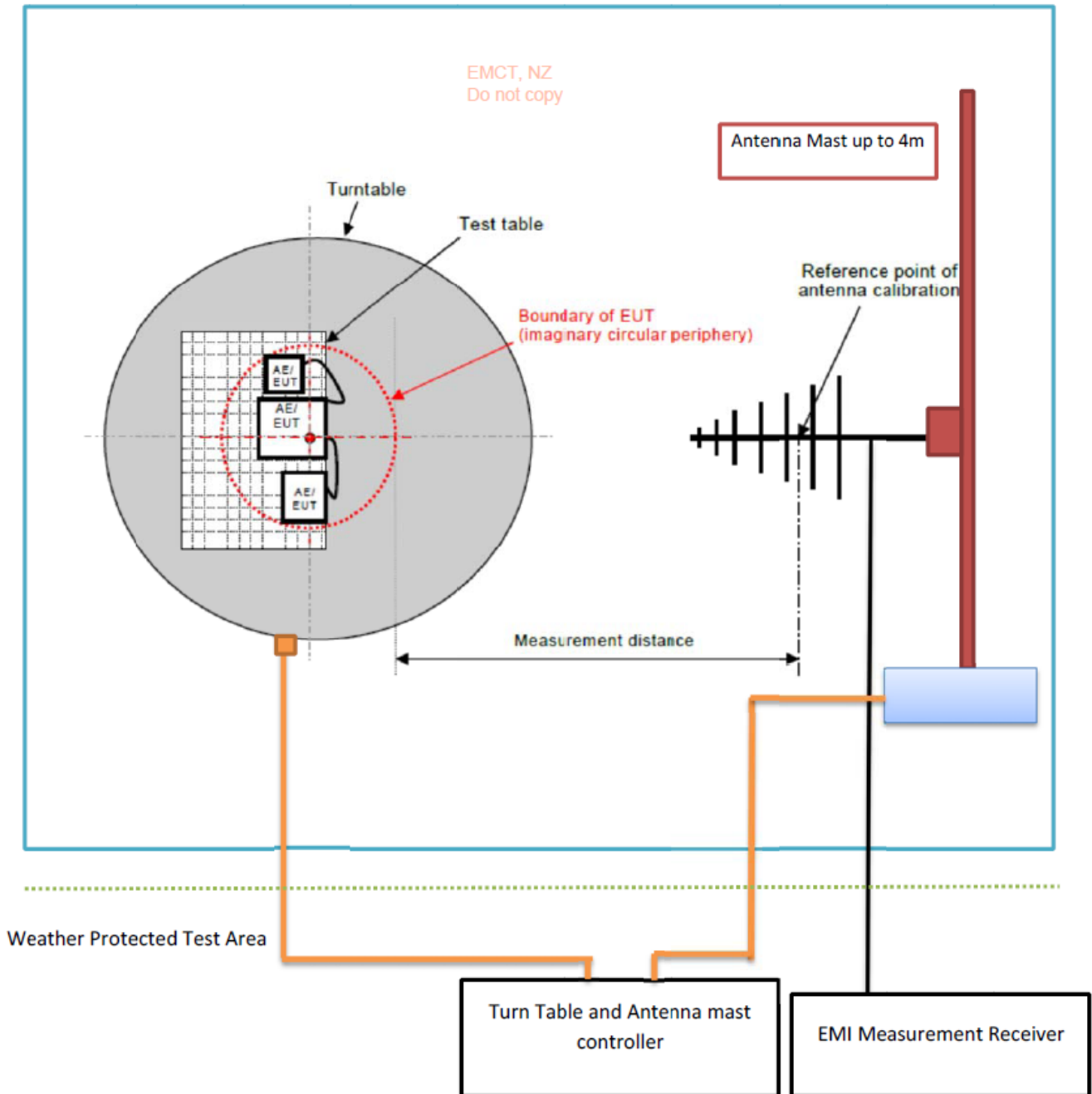

Below 30 MHz: Loop Antenna; Measurement distance: 10 m

30 MHz-300 MHz: Bi conical Antenna; Measurement distance: 3 m

300 MHz- 1000 MHz: Log Periodic Antenna; Measurement distance: 3 m

EMI Receiver Used: ESIB40

## Section 15.209: 13.560 MHz transmitter below 30 MHz spurious emission measurements

Loop Orientation	Frequency (MHz)	Level (dB $\mu$ V/m)	Limit (dB $\mu$ V/m)	Margin (dB)	Result
Loop-1	27.120	16.7	48.6	31.9	Pass
Loop-2	27.120	20.7	48.6	27.9	Pass

Testing was carried out when the device was transmitting continuously.

Magnetic loop measurements were attempted at a distance of 10 metres.

A receiver with a Quasi Peak detector with a 9 kHz bandwidth was used between 490 kHz – 30.0 MHz.

FCC part 15.209 emission limits are as shown below:

Frequency (MHz)	Field Strength ( $\mu$ V/m)	Measurement Distance (m)
0.009-0.490	2400/F (kHz)	300
0.490-1.705	24000/ F (kHz)	30
1.705-30.0	30	30
30-88	100	3
88-216	150	3
216-960	200	3
Above 960	500	3

The 30 metre limit between 1.705 MHz – 30 MHz has been scaled by a factor of 40 dB per decade, as per section 15.31 (f) (2).

The limit at 27.120 MHz when measured at 30 metres is 30 uV/m or 29.54 dBuV/m.

Therefore when the limit is scaled at 10 metres will be 48.6 dBuV/m as detailed below.

$$\begin{aligned} &= 29.54 \text{ dBuV/m} + \{-40 \text{ dB/decade} * (\log(10) - \log(30))\} \\ &= 29.54 \text{ dBuV/m} + \{-40 \text{ dB/decade} * (1.000 - 1.477)\} \\ &= 29.54 \text{ dBuV/m} + \{-40 \text{ dB/decade} * -0.477\} \\ &= 29.54 \text{ dBuV/m} + 19.08 \\ &= 48.6 \text{ dBuV/m} \end{aligned}$$

The spurious emission observed does not exceed the level of the fundamental emission

**Result:** Complies.

Measurement uncertainty with a confidence interval of 95% is:

- Free radiation tests (100 kHz – 30 MHz)  $\pm 4.8$  dB

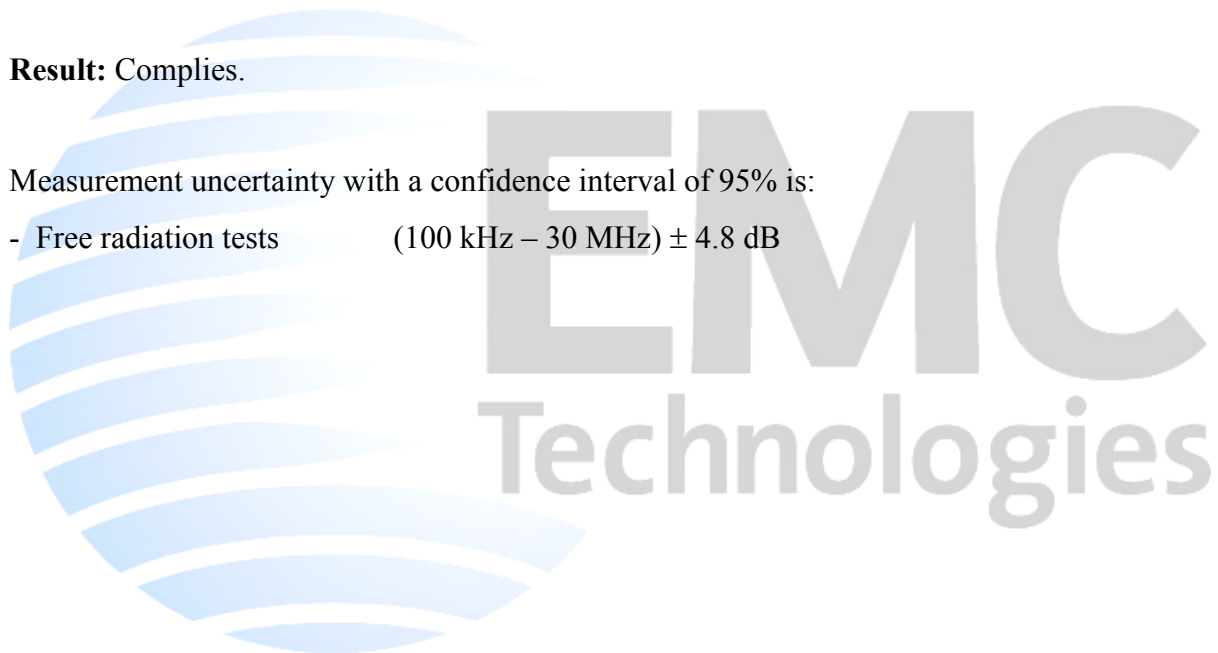

## Section 15.209: Spurious Emissions (above 30 MHz)

Measurements between 30 – 1000 MHz have been made at a distance of 3 metres.

The limits as described in Section 15.209 have been applied.

### 13.560 MHz card reader specific emissions:

Frequency (MHz)	Vertical (dB $\mu$ V/m)	Horizontal (dB $\mu$ V/m)	Limit (dB $\mu$ V/m)	Margin (dB)	Result	Antenna Polarisation
40.680	36.9	28.5	40.0	3.1	Pass	Vertical
54.240	26.1	-	40.0	13.9	Pass	Vertical
67.800	33.2	27.4	40.0	6.8	Pass	Vertical
69.040	23.2	-	40.0	16.8	Pass	Vertical
73.360	21.2	-	40.0	18.8	Pass	Vertical
284.760	30.0	33.0	46.0	13.0	Pass	Horizontal
311.880	31.7	31.5	46.0	14.3	Pass	Vertical
339.000	28.3	-	46.0	17.7	Pass	Vertical

No further emissions were detected within 15 dB of the limit when measurements were made between 30 – 2000 MHz using both vertical and horizontal polarisations.

**Result:** Complies.

Free radiation tests (30 – 25,000 MHz)  $\pm$  4.1 dB



### Section 15.225: Fundamental emission:

Measurements were made using a magnetic loop antenna and a receiver with a quasi-peak detector using a 9 kHz bandwidth

FCC Part 15.225, Operation within the band 13.110-14.010 MHz states that, the field strength of any emission shall not exceed the following limits:

- 15.848 mV/m (84 dB $\mu$ V/m) at 30 m, within the band 13.553-13.567 MHz
- 334  $\mu$ V/m (50.5 dB $\mu$ V/m) at 30 m, within the bands 13.410-13.553 MHz and 13.567-13.710 MHz
- 106  $\mu$ V/m (40.5 dB $\mu$ V/m) at 30 m, within the bands 13.110-13.410 MHz and 13.710-14.010 MHz
- FCC part 15.209 general field strength limits for frequencies outside the band 13.110-14.010 MHz

Measurements were made at a distance of 10 metres with the limit being determined by using the extrapolation factor of 40 dB per decade limit, as detailed in section 15.31 f (2).

The limit at 30 m at 13.560 MHz is 15,848 uV/m or 84.0 dBuV/m.

Applying the extrapolation factor of 40 dB/ per decade, the limit is 103.1 dBuV/m.

$$\begin{aligned} &= 84.0 \text{ dBuV/m} + \{-40 \text{ dB/decade} * (\log(10) - \log(30))\} \\ &= 84.0 \text{ dBuV/m} + 19.08 \\ &= 103.1 \text{ dBuV/m} \end{aligned}$$

Testing was also carried out to determine whether a variation in the supply voltage would cause a significant change in field strength.

The Gallagher controller (ancillary) input voltage which is supplied by the client supplied AC to DC convertor was varied by +/-15% and no significant variations in the emission level was found.

Voltage (Vac)	Frequency (MHz)	Level (dBuV/m)	Limit (dBuV/m)	Margin (dB)
+15% of Vac	13.560	56.8	103.1	46.3
Nominal (120Vac)	13.560	56.8	103.1	46.3
-15% of Vac	13.560	56.8	103.1	46.3

**Result:** Complies.

Measurement uncertainty with a confidence interval of 95% is:

Free radiation tests (100 kHz – 30 MHz)  $\pm$  4.8 dB

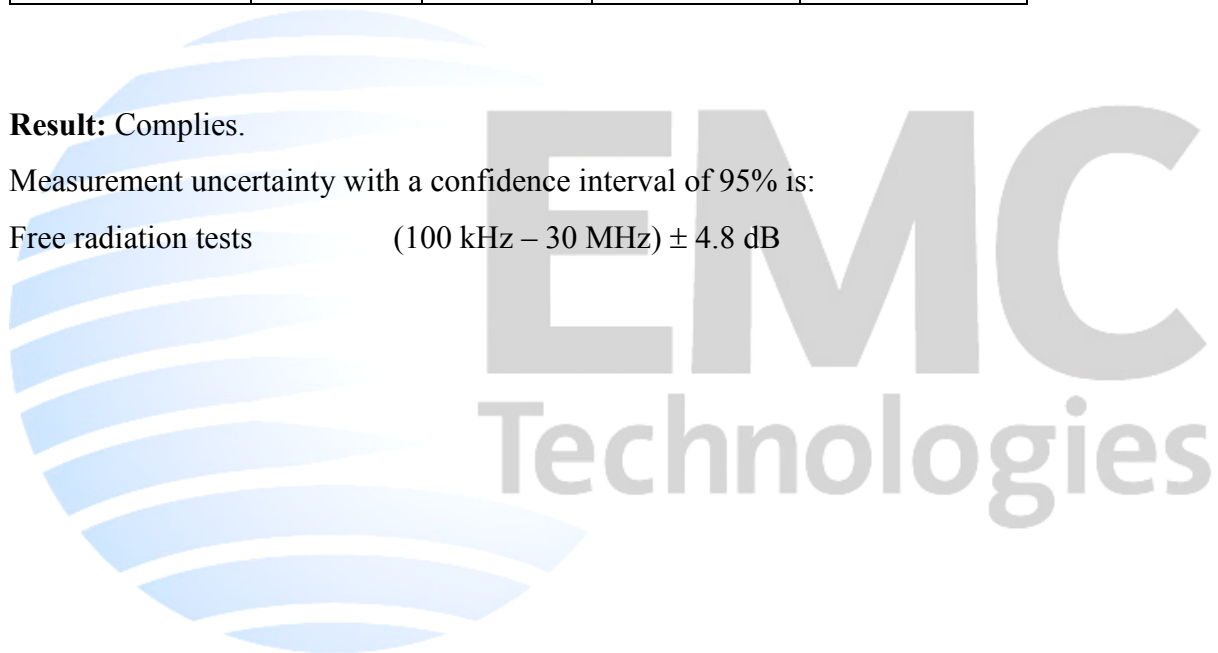

Representative spectrum analyser plots below show the carrier and modulation peaks within, +/- 2.5 MHz and +/- 1.5 MHz of the carrier.

**Fundamental emission: +/- 2500 kHz**



Ref Lvl	Marker 1 [T1]	RBW	10 kHz	RF Att	40 dB
105 dB*	57.86 dB $\mu$ V/m	VBW	30 kHz		
	13.56300601 MHz	SWT	125 ms	Unit	dB $\mu$ V/m

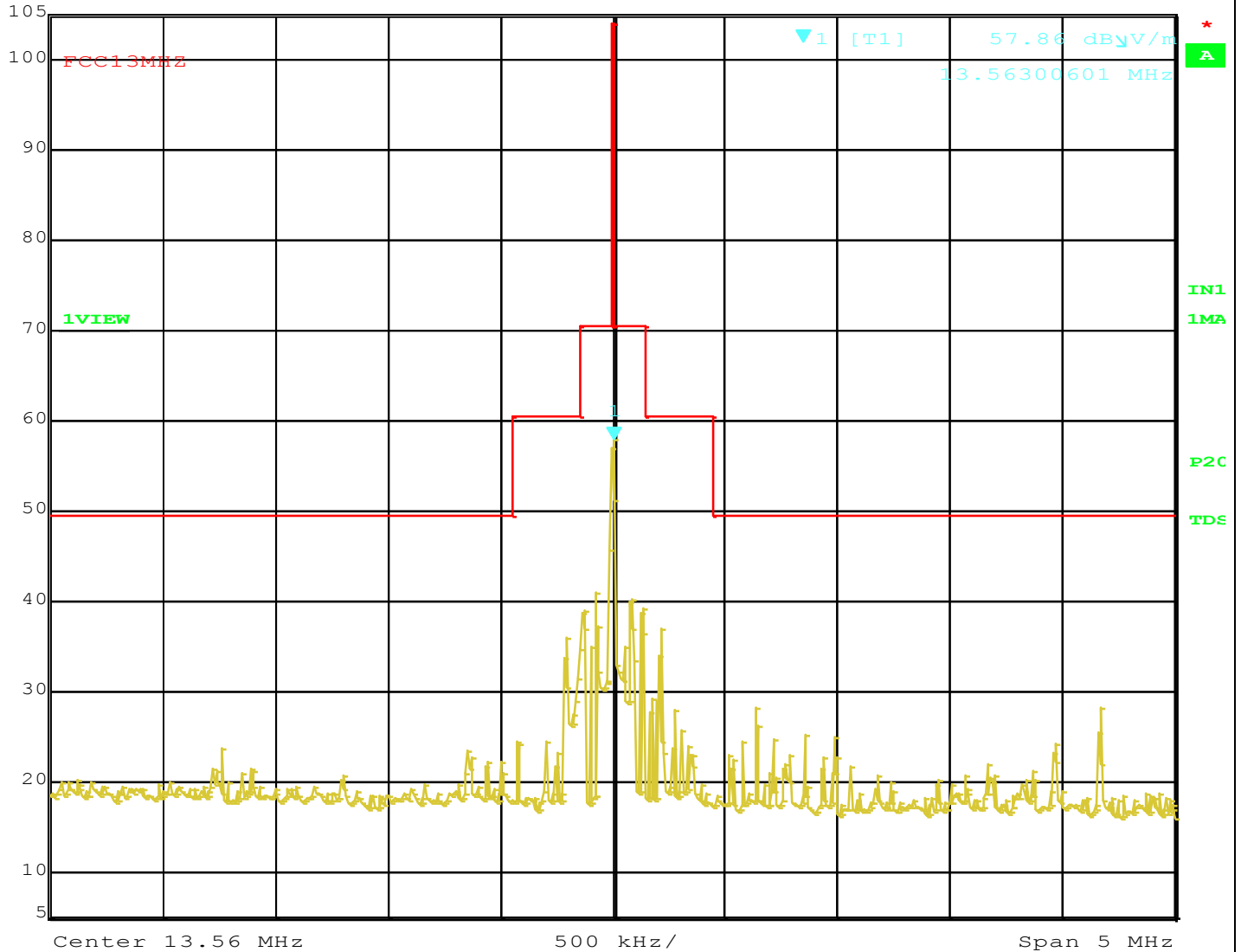

Date: 18.NOV.2022 13:25:17

# Fundamental emission: +/- 1500 kHz



	Marker 1 [T1]	RBW	10 kHz	RF Att	10 dB
Ref Lvl	57.41 dB $\mu$ V/m	VBW	30 kHz		
60 dB*	13.56300601 MHz	SWT	76 ms	Unit	dB $\mu$ V/m

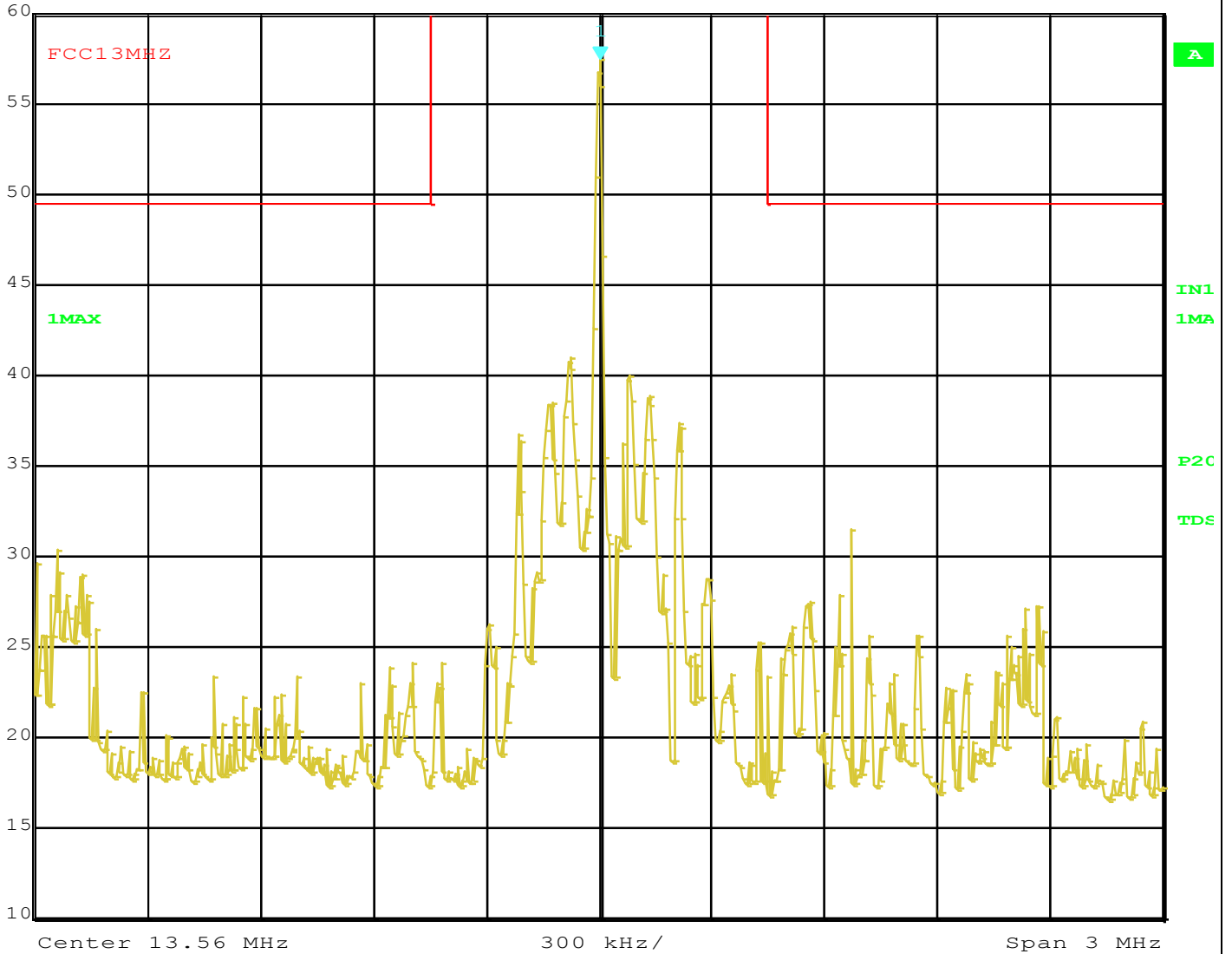

Date: 18.NOV.2022 13:14:55

**Section 15.225: Frequency tolerance:**

The frequency tolerance of the carrier is required to be +/- 0.01% of operating frequency when the temperature is varied between -20 degrees C and +50 degrees C.

The device operates nominally on 13.560 MHz which gives a frequency tolerance of +/- 1,356.0 Hz.

Temperature (°C)	Frequency (MHz)	Difference (Hz)
+50	13.559489	-511
+40	13.559459	-541
+30	13.559454	-546
+20	13.559466	-534
+10	13.559474	-526
0	13.559482	-518
-10	13.559492	-508
-20	13.559487	-513

Input voltage to the Gallagher Controller (Ancillary) was varied by +/- 15% at 20 degrees C (ambient).

Voltage (Vdc)	Frequency (MHz)	Difference (Hz)
11.6	13.559466	-534
13.6	13.559466	-534
15.6	13.559466	-534

**Result:** Complies.

Measurement uncertainty with a confidence interval of 95% is:

Frequency tolerance  $\pm$  50 Hz

### Radio bay measurement setup

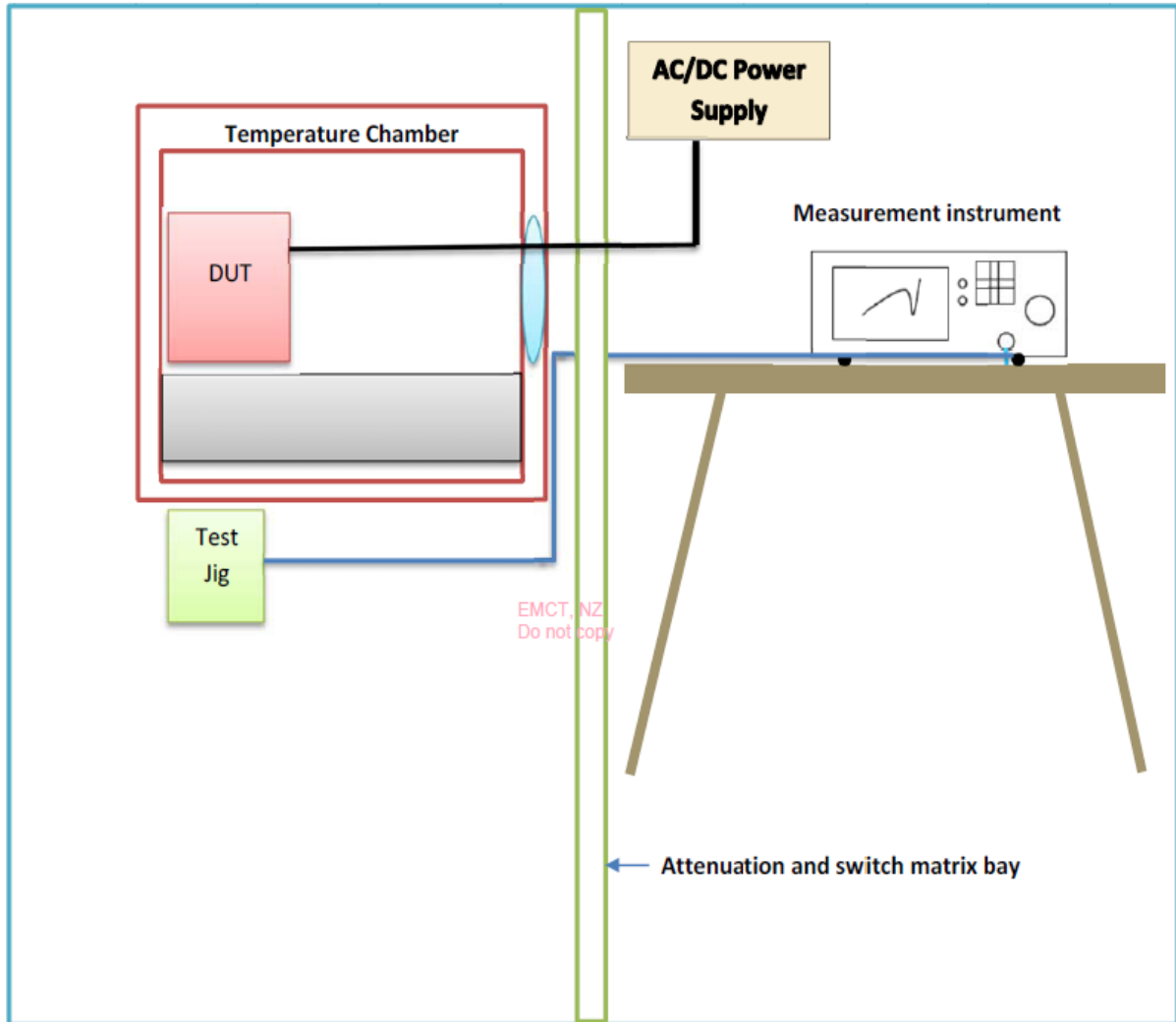

Following test instruments were used to carry out this test:

Instrument	Manufacturer	Model
Thermal chamber	Contherm	M180F
Thermometer	DSIR	RT200
EMI Receiver/Spectrum Analyser	Keysight	N9038A
Power Supply	6032A	8032A
Coaxial cables (3m)	Huber and Suhner Succoflex	340521/4
Coaxial cables (1m)	Huber and Suhner Succoflex	339901/4



## 7. TEST EQUIPMENT USED

Instrument	Manufacturer	Model	Serial No	Asset Ref	Cal Due	Period
Aerial Controller	EMCO	1090	9112-1062	RFS 3710	Not applic	N/a
Aerial Mast	EMCO	1070-1	9203-1661	RFS 3708	Not applic	N/a
Biconical Antenna	Schwarzbeck	BBA 9106	9124-420	3802	21 Nov 2023	2 years
Horn Antenna	Electrometrics	RGA-60	6234	E1494	6 Jan 2023	3 years
Log Periodic	Schwarzbeck	VUSLP 9111	9111-112	EMC4025	16 Nov 2023	3 years
Loop Antenna	EMCO	6502	9003-2485	3798	6 Jan 2023	3 years
Mains Network	R & S	ESH2-Z5	881362/032	3628	11 Nov 2022	2 years
Receiver	R & S	ESHS 10	828404/005	3728	23 Nov 2023	2 year
Receiver	R & S	ESIB 40	100295	EMC4030	03 Jun 2023	2 year
Spectrum analyser	Keysight	N9038A	MY57290153	EMC4033	29 July 2023	2 year
Turntable	EMCO	1080-1-2.1	9109-1578	RFS 3709	Not applic	N/a
VHF Balun	Schwarzbeck	VHA 9103	9124-420	3801	21 Nov 2023	2 years
Heliacx cable	Andrews	L6PNM-RPD	22869	Oats Cable	30 Dec 2022	1 year
Succoflex cable	Huber and Suhner	104 3m n-n	339901/4	13938	20 Dec 2022	1 year
Succoflex cable	Huber and Suhner	104 1m n-n	340521/4	13937	20 Dec 2022	1 year
Power Supply	APT	7008	4170003	-	Not applic	N/a
Thermal chamber	Contherm	M180F	86025	N/a	N/a	N/a
Thermometer	DSIR	RT200	35	EMC4029	9 April 2023	5 years
Voltage Variac	Powerteck	SRV-5	RFS3800	-	-	Not applic

At the time of testing all test equipment was within calibration

## 8. ACCREDITATIONS

Testing was carried out in accordance with EMC Technologies NZ Ltd designation as a FCC Accredited Laboratory by International Accreditation New Zealand, designation number: NZ0002 under the APEC TEL MRA.

All testing was carried out in accordance with the terms of EMC Technologies (NZ) Ltd International Accreditation New Zealand (IANZ) Accreditation to NZS/ISO/IEC 17025.

All measurement equipment has been calibrated in accordance with the terms of the EMC Technologies (NZ) Ltd International Accreditation New Zealand (IANZ) Accreditation to NZS/ISO/IEC 17025.

International Accreditation New Zealand has International Laboratory Accreditation Council (ILAC) Mutual Recognition Arrangements for testing and calibration with various accreditation bodies in a number of economies.

This includes NATA (Australia), UKAS (UK), SANAS (South Africa), NVLAP (USA), A2LA (USA), SWEDAC (Sweden).

Further details can be supplied on request

## 9. PHOTOGRAPHS

Front face

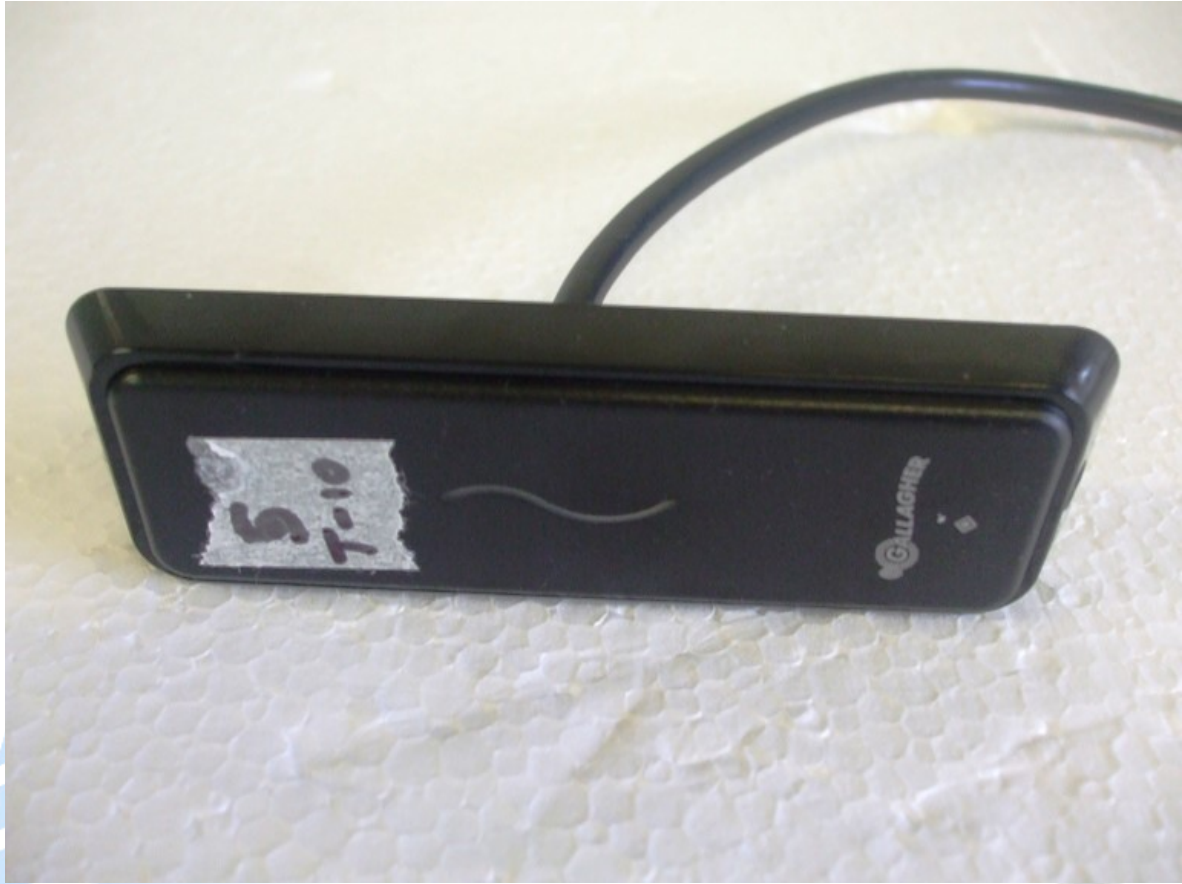

Rear Face



Side face -1



Side Face-2





Labels- the back cover of the device has been unscrewed to take label photos.



Ancillary equipment supplied by the client to facilitate testing of the product

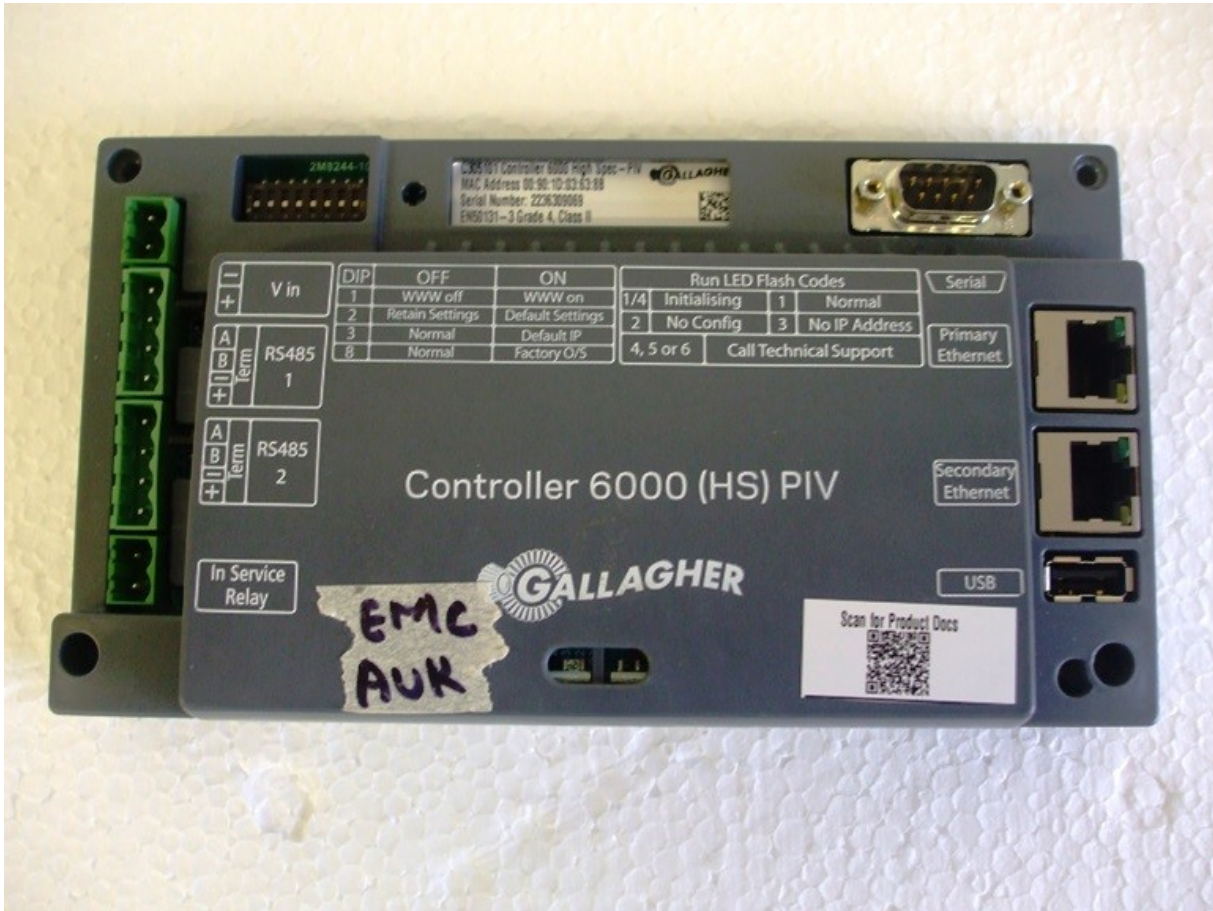

Technologies

Ancillary label





Conducted emissions test set up





Ancillary Equipment placed outside of the test area during radiated emissions testing



Radiated emission test set up



Radiated emission test set up (Cont...)





Test Antennas Used - Biconical Antenna



# Log periodic Antenna



## Loop Antenna

