



Installation Note

Gallagher T10 Mifare Reader



This equipment contains components that can be damaged by electrostatic discharge. Ensure both you and the equipment are earthed before beginning any servicing.



The Gallagher T10 Mifare Reader

The Gallagher T10 Mifare reader is a smart card proximity reader. It can be installed as either an entry reader or exit reader.

The reader can read Mifare DESFire EV1, Mifare Plus and Mifare Classic cards.

The reader sends information to the Cardax FT Controller and acts upon information sent from the Cardax FT Controller. The reader itself does not make any access decisions.

The Gallagher T10 Mifare reader uses the "Cardax IV Reader" communications protocol to communicate with the Cardax FT Controller.

Before you begin

Shipment Contents

Check the shipment contains the following items:

- 1 x Gallagher T10 Mifare reader fascia assembly
- 1 x Gallagher T10 Mifare reader base
- 1 x Gallagher T10 Mifare reader installation note
- 1 x M3 Torx Post Security screw
- 2 x self tapping pan head pozi fixing screws

Power Supply

The Gallagher T10 Mifare reader receives power from the device to which it is connected. The reader is designed to operate over a supply voltage range of 9 - 16Vdc measured at the reader terminals. The operating current will be approximately 40mA (at 16Vdc) and 70mA (at 9Vdc). The operating current will increase to approximately 120mA (at 12Vdc) momentarily during a card read, beeper and LED activity.

The power source should be linear or a good quality switched-mode power supply. The performance of the reader may be affected by a low quality, noisy power supply.

Cabling

The Gallagher T10 Mifare reader requires a minimum cable size of 4 core 24 AWG (0.2mm²) stranded security cable. This cable allows the transmission of data (2 wires) and power (2 wires). When using a single cable to carry both power supply and data, both the power supply voltage drop and data requirements must be considered. For good engineering design, it is recommended that the voltage at the reader should be approximately 12Vdc.

The critical specifications for the cable are:

Data: The capacitance between any two wires or between a wire and any shielding should be less than 24nF

Power supply: The voltage at the reader must be at least 9Vdc

Examples of approved cables for connecting a single Gallagher T10 Mifare reader to a Controller and power supply, showing maximum cable lengths for each type of cable and the associated circuits are:

Cable type	Combined power and data in a single cable
CAT5e	100m (320ft)
SEC472 (4 x 0.2mm ²)	100m (320ft)
SEC4142 (4 x 0.4mm ²)	100m (320ft)
BELDEN 8723 (22 AWG)	152m (500ft)
BELDEN 9842 (24 AWG)	152m (500ft)

Distance between Proximity Readers

The distance separating any two proximity readers must not be less than 200mm (8 inches) in all directions.

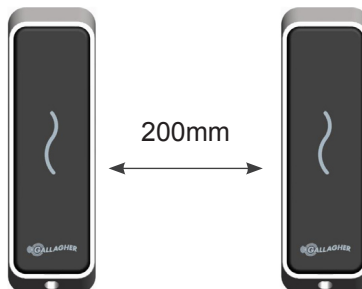

When mounting a proximity reader on an internal wall, check that any reader fixed to the other side of the wall is not less than 200mm (8 inches) away.

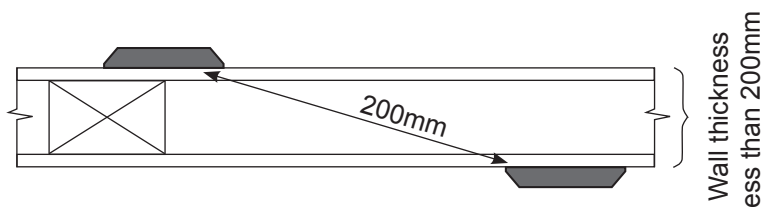

Installation

The Gallagher T10 Mifare reader is designed to be mounted on any solid flat surface. However installation on metal surfaces, particularly those with a large surface area will reduce read range. The extent to which the range is reduced will depend upon the type of metal used.

The recommended mounting height for the reader is 1.1m (3.6ft) from the floor level to the centre of the reader device. However this may vary in some countries and you should check local regulations for variations to this height.

1. Using the drill template at the back of this installation note as a guide, drill all three holes. Drill the 13mm (1/2 inch) diameter centre hole (this is the centre hole for which the building cable will exit the mounting surface) and the two fixing holes.
2. Run the building cabling out through the centre hole and through the reader base.
3. Secure the base to the mounting surface using the two fixing screws provided. It is important the base of the reader is flush with and tight against the mounting surface.

Note: Ensure the centre hole allows the cable to run freely out through the mounting surface, so that the reader facia can clip into the base.

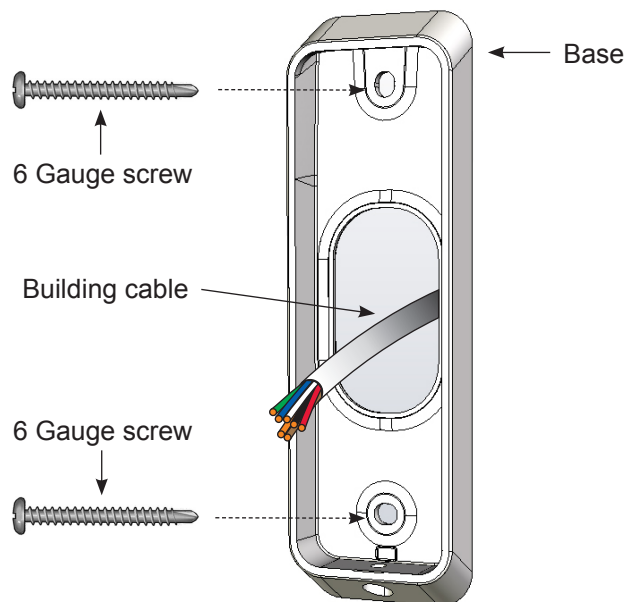

4. Connect the reader tail extending from the facia assembly to the building cable. Connect the wires shown below.

Note: Do not cut the 'Reserved' wires, they may be required later.

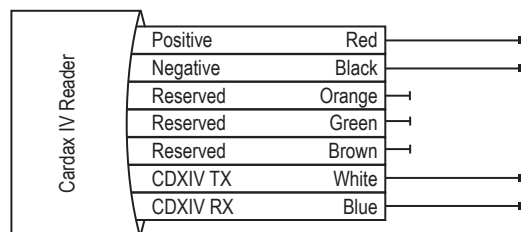

5. Fit the facia assembly into the base by clipping the small lip, into the top of the base and holding the top, press the bottom of the facia assembly down into the base.

6. Insert the M3 Torx Post Security screw (using a T10 Torx Post Security screwdriver) through the hole at the bottom of the base to secure the facia assembly.

Note: The recommended torque for the security screw is 0.7Nm (0.5 lb/ft). It is important not to exceed the maximum torque of 1.5Nm (1.1 lb/ft).

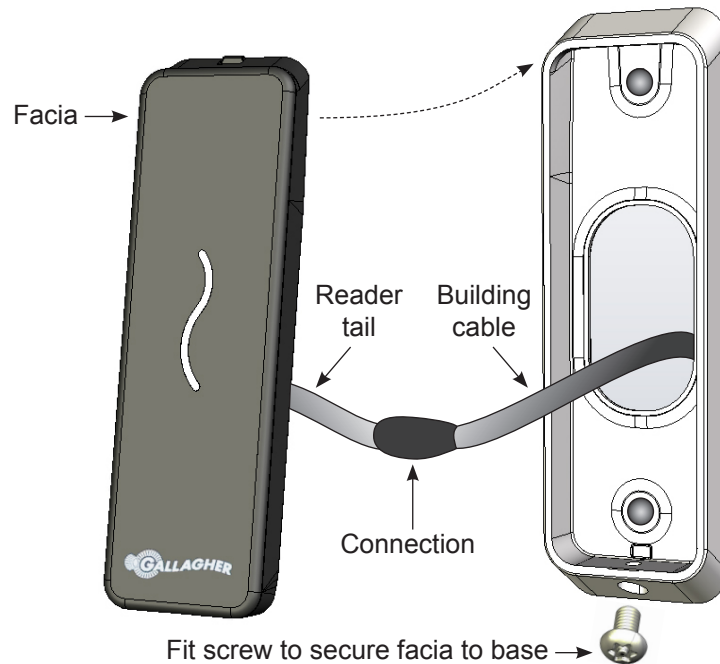

7. Removal of the facia assembly is a simple reversal of these steps.

Connections

A Gallagher T10 Mifare reader can connect to one of the following devices using the "Cardax IV Reader" communications protocol:

- Cardax FT Reader Module (for the Controller 6000)
- Cardax FT GBUS Universal Reader Interface (Cardax FT GBUS URI)
- Cardax FT Controller 3000-4R or 3000-8R
- Cardax FT Universal Reader Interface (Cardax FT URI)
- Cardax FT Reader I/O Interface

Connecting to the Cardax FT Reader Module (for the Controller 6000)

Connect the wires to the sockets as shown:

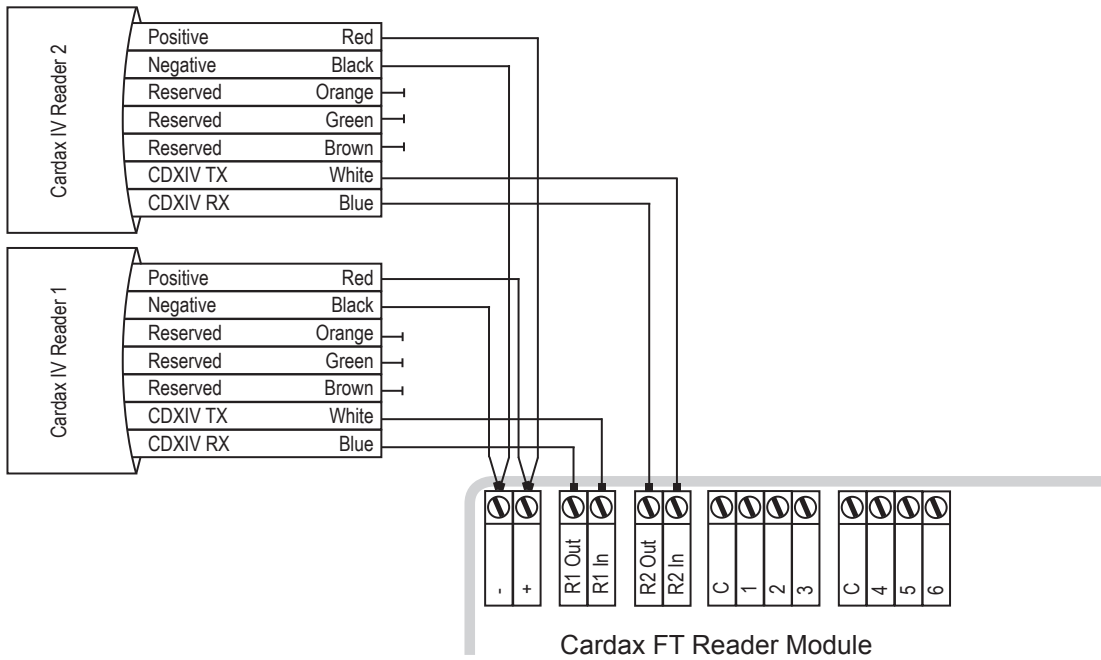

Connecting to the Cardax FT GBUS Universal Reader Interface

Connect the wires to the sockets as shown in either of the following diagrams:

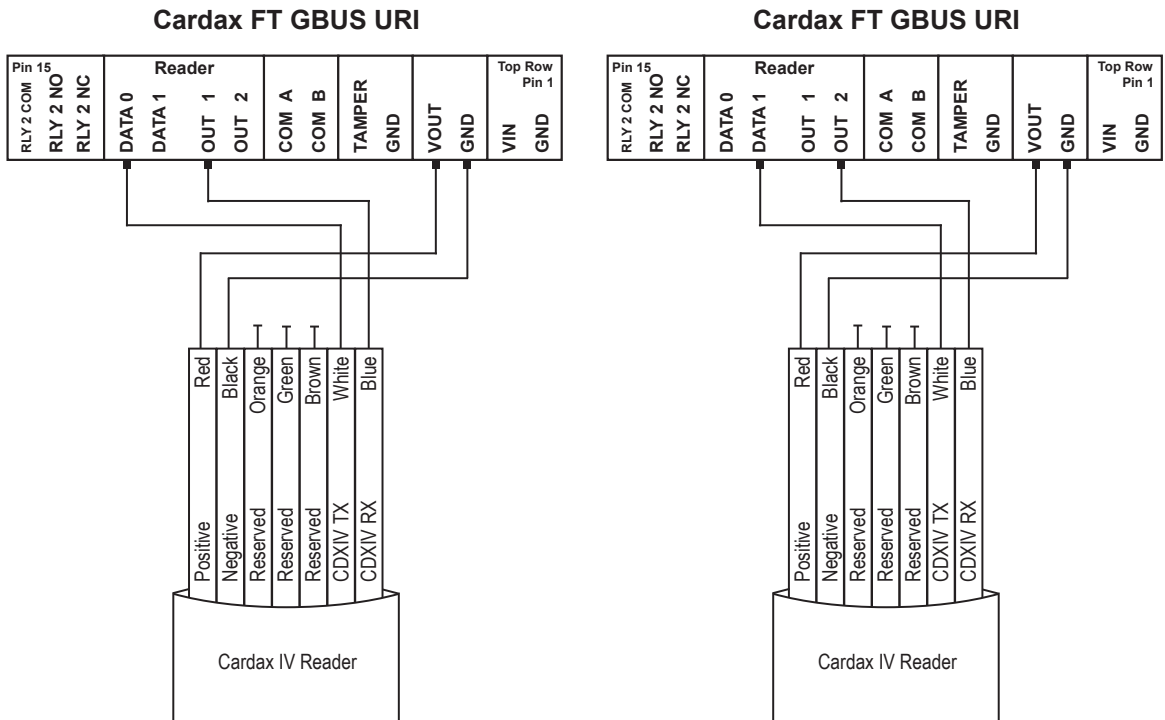

Connecting to the Cardax FT Controller 3000-4R or 3000-8R

The Cardax FT Controller 3000-4R can interface up to four Gallagher T10 Mifare readers into the Cardax FT Command Centre system. The Cardax FT Controller 3000-8R can interface up to eight Gallagher T10 Mifare readers into the Cardax FT Command Centre system.

The ports to which the Gallagher T10 Mifare reader can connect are set up as groups, as follows:

- Two groups (numbered 1 and 2) on the Controller 3000-4R, and
- Four groups (numbered 1 to 4) on the Controller 3000-8R

Each group provides connection for two Gallagher T10 Mifare readers. Refer to the following diagram for the location of the ports on the Cardax FT Controller 3000-8R.

Note: Even though there are only two groups of ports on the Cardax FT Controller 3000-4R, they are located in the same position.

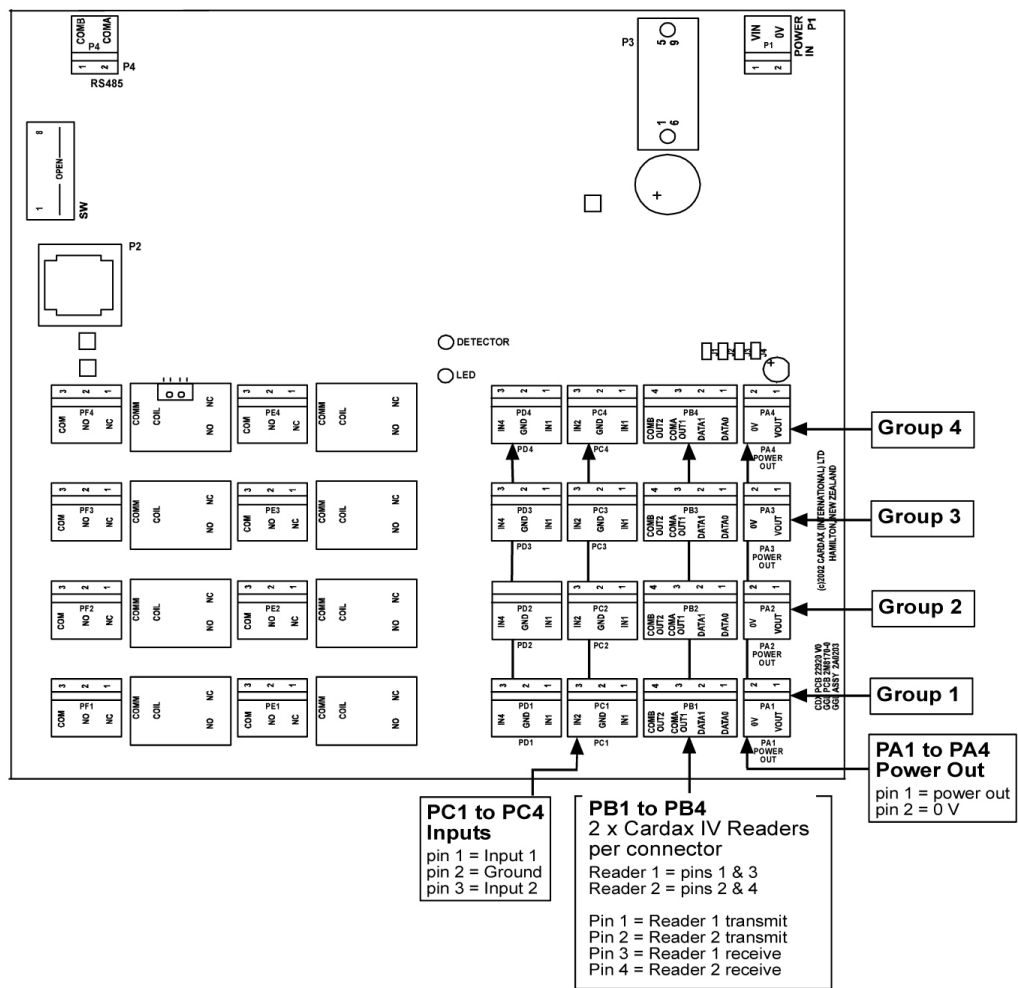

Make the connections from the Gallagher T10 Mifare reader to either the Cardax FT Controller 3000-4R or 3000-8R as shown:

Cardax FT Controller 3000-4R or 3000-8R

Group

PB1 and PA1... to... PB2 and PA2 (3000-4R)

PB4 and PA4 (3000-8R)

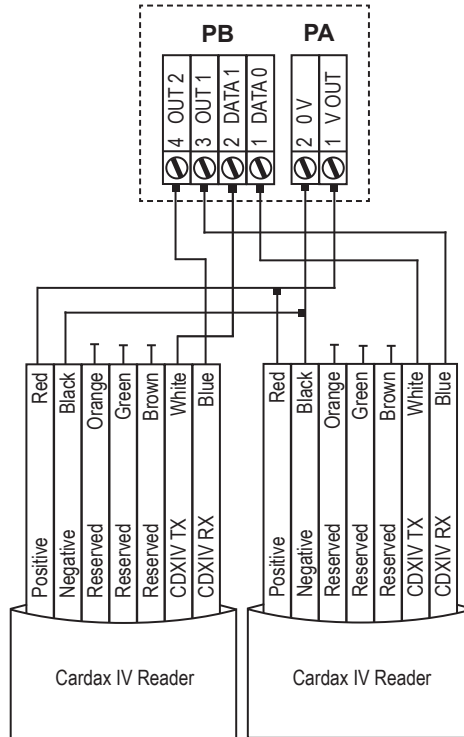

Note: Within each group, you cannot mix Cardax IV readers with Wiegand Readers. This is because connecting one Wiegand reader requires all four pins on plug PB. For example, if you connect a Cardax IV reader to Port 1 of Group 1, Port 2 of Group 1 can only connect to another Cardax IV reader.

Technical Specifications

Technical Specifications	
Routine maintenance	Not applicable for this reader
Cleaning	This reader should only be cleaned with a clean, lint free, damp cloth
Power required	Voltage: 9Vdc - 16Vdc
	Current: 40mA (at 16Vdc) 70mA (at 9Vdc) The current will increase momentarily during a card read, beeper and LED activity: 120mA (at 12Vdc)
Environmental	Operating temperature: -30°C to +70°C Note: Direct sunlight may increase the internal reader temperature above the ambient temperature level
	Humidity: 95% non-condensing
	Environmental Protection: IP67* * Pending final test results
Mounting height	1.1 m (3.6ft) to centre

Approvals and Standards

RoHS
COMPLIANT

This product complies with the environmental regulations for the Restriction of Hazardous Substances in electrical and electronic equipment (RoHS). The RoHS directive prohibits the use of electronic equipment containing certain hazardous substances in the European Union.

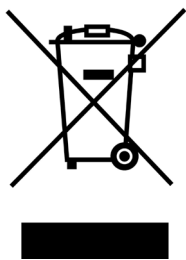

This symbol on the product or its packaging indicates that this product must not be disposed of with other waste. Instead, it is your responsibility to dispose of your waste equipment by handing it over to a designated collection point for the recycling of waste electrical and electronic equipment. The separate collection and recycling of your waste equipment at the time of disposal will help conserve natural resources and ensure that it is recycled in a manner that protects human health and the environment. For more information about where you can drop off your waste equipment for recycling, please contact your local city recycling office or the dealer from whom you purchased the product.



ACN 002 132 943

FCC

This equipment has been tested and found to comply with the limits for a Class B digital device, pursuant to Part 15 of the FCC Rules. These limits are designed to provide reasonable protection against harmful interference in a residential installation. This equipment generates, uses and can radiate radio frequency energy and, if not installed and used in accordance with the instructions, may cause harmful interference to radio communications. However, there is no guarantee that interference will not occur in a particular installation.

If this equipment does cause harmful interference to radio or television reception, which can be determined by turning the equipment off and on, the user is encouraged to try to correct the interference by one or more of the following measures:

- Reorient or relocate the receiving antenna.
- Increase the separation between the equipment and receiver.
- Connect the equipment into an outlet on a circuit different from that to which the receiver is connected.
- Consult the dealer or an experienced radio/TV technician for help.

Note: Changes or modifications not expressly approved by Gallagher Group Limited could void the user's authority to operate this equipment.

Drill Template

