

FCC - TEST REPORT

Report Number : **60.790.21.004.01R02** Date of Issue : August 30, 2021

Model : ROX 4.0

Product Type : GPS Bike Computer

Applicant : ZEITBIKE LLC

Address : 298 Dalton Street, Ventura, California 93003-1539,
United States.

Production Facility : SIGMA-Elektro GmbH

Address : Dr. Julius Leber Str.15, Neustadt 67433, Germany

Test Result : Positive Negative

Total pages including Appendices : 22

TÜV SÜD Certification and Testing (China) Co., Ltd. Shenzhen Branch is a subcontractor to TÜV SÜD Product Service GmbH according to the principles outlined in ISO 17025.

TÜV SÜD Certification and Testing (China) Co., Ltd. Shenzhen Branch reports apply only to the specific samples tested under stated test conditions. Construction of the actual test samples has been documented. It is the manufacturer's responsibility to assure that additional production units of this model are manufactured with identical electrical and mechanical components. The manufacturer/importer is responsible to the Competent Authorities in Europe for any modifications made to the production units which result in non-compliance to the relevant regulations. TÜV SÜD Certification and Testing (China) Co., Ltd. Shenzhen Branch shall have no liability for any deductions, inferences or generalizations drawn by the client or others from TÜV SÜD Certification and Testing (China) Co., Ltd. Shenzhen Branch issued reports.

This report is the confidential property of the client. As a mutual protection to our clients, the public and ourselves, extracts from the test report shall not be reproduced except in full without our written approval

1 Table of Contents

1 Table of Contents.....	2
2 Description of Equipment Under Test	3
3 Summary of Test Standards	4
4 Details about the Test Laboratory	5
4.1 Test Equipment Site List	6
4.2 Measurement System Uncertainty	7
5 Summary of Test Results.....	8
6 General Remarks.....	9
7 Test Setups.....	10
7.1 Radiated test setups Below 1GHz.....	10
7.2 Radiated test setups Above 1GHz	10
7.3 AC Power Line Conducted Emission test setups	11
7.4 Conducted RF test setups.....	11
8 Emission Test Results	12
8.1 Radiated Emission.....	12
8.2 20dB & 99% Bandwidth	14
8.3 Conducted Emission at AC Power line.....	15
8.4 Antenna Requirement.....	17
9 Test setup procedure	18
10 Appendix A - General Product Information	22

2 Description of Equipment Under Test

Description of the Equipment Under Test

Product: GPS Bike Computer

Model no.: ROX 4.0

FCC ID: M5LROX40

Rating: 3.7 VDC, 550 mAh (Li-poly rechargeable battery)
5.0 VDC 1000mA (USB Port for Charging)

Frequency: ANT+
2457MHz

Antenna gain: 5.54 dBi

Number of operated channel: 1

Modulation: GFSK

Auxiliary Equipment and Software Used during Test:

DESCRIPTION	MANUFACTURER	MODEL NO.	S/N
Computer	Lenovo	X220	0A72168
AC/DC adapter	Apple	A1537	/

Auxiliary Software Used during Test:

DESCRIPTION	SOFTWARE NAME	VERSION	REMARK
RF Test Mode Software	nRFgo	1.16	Provided by applicant



3 Summary of Test Standards

Test Standards

FCC Part 15 Subpart C 10-1-20 Edition Federal Communications Commission, PART 15 — Radio Frequency Devices, Subpart C — Intentional Radiators

All the tests were performed using the procedures from ANSI C63.4(2014) and ANSI C63.10 (2013).

4 Details about the Test Laboratory

Site 1

Company name: TÜV SÜD Certification and Testing (China) Co., Ltd. Shenzhen Branch
 Building 12&13 Zhiheng Wisdomland Business Park,
 Nantou Checkpoint Road 2, Nanshan District,
 Shenzhen 518052, P.R.China
 FCC Registration Number: 514049
 ISED test site number: 10320A

Emission Tests	
Test Item	Test Site
FCC Part 15 Subpart C	
FCC Title 47 Part 15.205, 15.209 & 15.249 & Radiated Emission	Site 1
FCC Title 47 Part 15.207 Conduct Emission	Site 1
FCC Title 47 Part 15.215 20dB & 99% Bandwidth	Site 1
FCC Title 47 Part 15.203 Antenna Requirement	Site 1

4.1 Test Equipment Site List

Radiated emission Test – Site 1

DESCRIPTION	MANUFACTURER	MODEL NO.	SERIAL NO.	CAL. DUE DATE
EMI Test Receiver	Rohde & Schwarz	ESR 26	101269	2022-6-29
Signal Analyzer	Rohde & Schwarz	FSV40	101031	2022-6-22
Loop Antenna	Rohde & Schwarz	HFH2-Z2	100398	2022-7-7
Trilog Super Broadband Test Antenna	Schwarzbeck	VULB 9163	707	2022-8-4
Horn Antenna	Rohde & Schwarz	HF907	102294	2022-7-5
Wideband Horn Antenna	Q-PAR	QWH-SL-18-40-K-SG	12827	2022-6-21
Pre-amplifier	Rohde & Schwarz	SCU 18	102230	2022-6-21
Pre-amplifier	Rohde & Schwarz	SCU 40A	100432	2022-7-30
Attenuator	Agilent	8491A	MY39264334	2022-6-21
3m Semi-anechoic chamber	TDK	9X6X6	----	2022-10-28
Test software	Rohde & Schwarz	EMC32	Version 9.15.00	N/A

Conducted Emission Test – Site 1

DESCRIPTION	MANUFACTURER	MODEL NO.	SERIAL NO.	CAL. DUE DATE
EMI Test Receiver	Rohde & Schwarz	ESR 3	101782	2022-6-29
LISN	Rohde & Schwarz	ENV4200	100249	2022-6-12
LISN	Rohde & Schwarz	ENV432	101318	2022-6-12
LISN	Rohde & Schwarz	ENV216	100326	2022-6-12
LISN	Rohde & Schwarz	ENV216	102472	2022-6-12
ISN	Rohde & Schwarz	ENY81	100177	2022-6-12
ISN	Rohde & Schwarz	ENY81-CA6	101664	2022-6-12
High Voltage Probe	Schwarzbeck	TK9420(VT9420)	9420-584	2022-6-23
RF Current Probe	Rohde & Schwarz	EZ-17	100816	2022-6-28
Attenuator	Shanghai Huaxiang	TS2-26-3	080928189	2022-6-21
Test software	Rohde & Schwarz	EMC32	Version9.15.00	N/A
Shielding Room	TDK	CSR #1	----	2022-11-07

20dB & 99% Bandwidth – Site 1

DESCRIPTION	MANUFACTURER	MODEL NO.	SERIAL NO.	CAL. DUE DATE
Signal Analyzer	Rohde & Schwarz	FSV40	101030	2022-6-21
RF Switch Module	Rohde & Schwarz	OSP120/OSP-B157	101226/100851	2022-6-21

4.2 Measurement System Uncertainty

Measurement System Uncertainty Emissions

System Measurement Uncertainty	
Items	Extended Uncertainty
Uncertainty for Radiated Emission in 3m chamber 9kHz-30MHz	4.76dB
Uncertainty for Radiated Emission in 3m chamber 30MHz-1000MHz	Horizontal: 5.12dB; Vertical: 5.10dB;
Uncertainty for Radiated Emission in 3m chamber 1000MHz-25000MHz	Horizontal: 5.01dB; Vertical: 5.00dB;
Uncertainty for Conducted Emission at AC Power Line 150kHz-30MHz	3.21dB
Uncertainty for conducted power test	1.16dB
Uncertainty for frequency test	0.6×10^{-7}

Measurement Uncertainty Decision Rule

Determination of conformity with the specification limits is based on the decision rule according to IEC Guide 115: 2007, clause 4.4.3 and 4.5.1.

5 Summary of Test Results

Emission Tests				
FCC Part 15 Subpart C				
Test Condition	Pages	Test Result		
		Pass	Fail	N/A
FCC Title 47 Part 15.205,15.209 & 15.249 Radiated Emission	12-13	<input checked="" type="checkbox"/>	<input type="checkbox"/>	<input type="checkbox"/>
FCC Title 47 Part 15.215 20dB & 99% Bandwidth	14	<input checked="" type="checkbox"/>	<input type="checkbox"/>	<input type="checkbox"/>
FCC Title 47 Part 15.207 Conduct Emission	15-16	<input checked="" type="checkbox"/>	<input type="checkbox"/>	<input type="checkbox"/>
FCC Title 47 Part 15.203 Antenna Requirement	17	<input checked="" type="checkbox"/>	<input type="checkbox"/>	<input type="checkbox"/>

. Remark:

6 General Remarks

Remarks

This submittal(s) (test report) is intended for **FCC ID: M5LROX40**, complies with Section 15.203, 15.205, 15.207, 15.209, 15.249 of the FCC Part 15, Subpart C rules.

The TX and RX range is 2457MHz.

SUMMARY:

- All tests according to the regulations cited on page 8 were

n - Performed

o - **Not** Performed

- The Equipment Under Test

n - **Fulfills** the general approval requirements.

o - **Does not** fulfill the general approval requirements.

Sample Received Date: March 01, 2021

Testing Start Date: March 02, 2021

Testing End Date: August 19, 2021

- TÜV SÜD Certification and Testing (China) Co., Ltd. Shenzhen Branch -

Reviewed by:

Prepared by:

Tested by:



Eric LI
EMC Project Manager

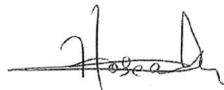

Hosea CHAN
EMC Project Engineer



Louise Liu
EMC Test Engineer

7 Test Setups

7.1 Radiated test setups Below 1GHz

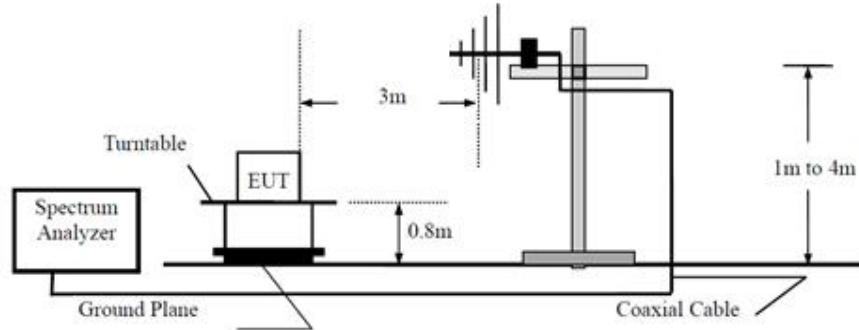

7.2 Radiated test setups Above 1GHz

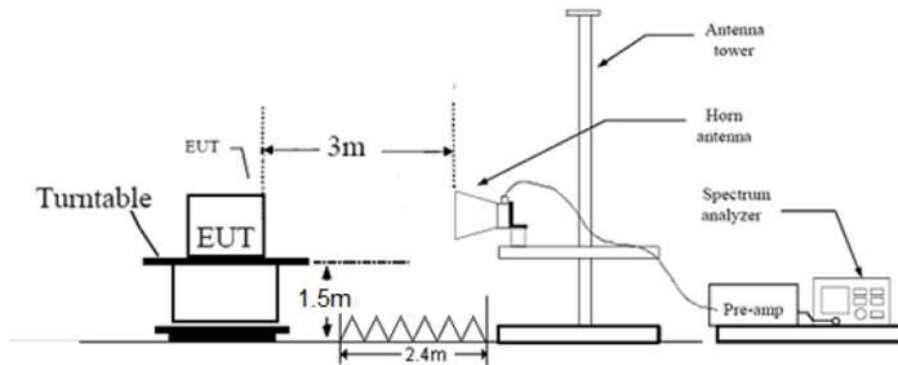

7.3 AC Power Line Conducted Emission test setups

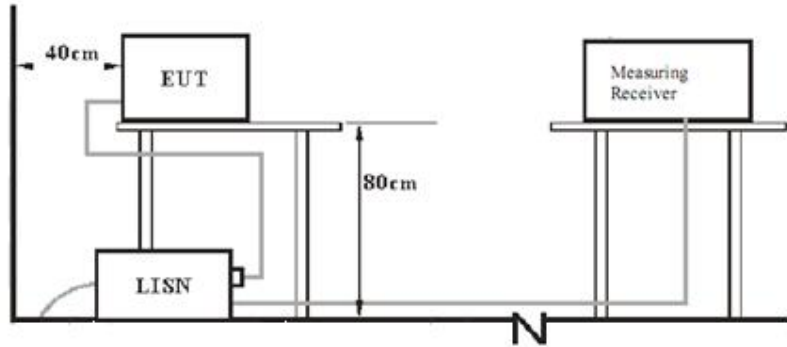

7.4 Conducted RF test setups

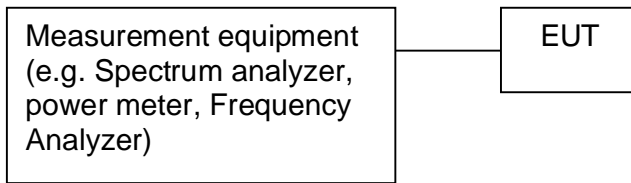

8 Emission Test Results

8.1 Radiated Emission

EUT: ROX 4.0
 Op Condition: Operated, TX Mode (2457MHz)
 Test Specification: FCC15.249 & 15.209, Antenna: Horizontal
 Comment: 3.7 VDC
 Remark: Measurement range up to 25GHz

Test Result	
<input checked="" type="checkbox"/>	Passed
<input type="checkbox"/>	Not Passed

Frequency MHz	Result dB μ V/m	Limit dB μ V/m	Margin dB	Detector PK/QP/AV	Corr. (dB)	RSE. or Fund.
48.187500	21.44	40.00	18.56	Quasi Peak	17.85	Spurious emission
100.325000	17.92	43.50	25.58	Quasi Peak	16.21	Spurious emission
201.750625	19.25	43.50	24.25	Quasi Peak	16.56	Spurious emission
427.154375	24.64	46.00	21.36	Quasi Peak	22.05	Spurious emission
583.870000	30.70	46.00	15.30	Quasi Peak	25.14	Spurious emission
902.757500	34.15	46.00	11.85	Quasi Peak	29.62	Spurious emission
1904.761905	46.62	74.00	27.38	Peak	-5.52	Spurious emission
2276.666667	47.80	74.00	26.20	Peak	-4.27	Spurious emission
2457.000000	84.17	74.00	-10.17	Peak	-3.79	Fundamental
5288.000000	37.44	74.00	36.56	Peak	1.86	Spurious emission
7368.500000	60.59	74.00	13.41	Peak	5.49	Spurious emission
7368.500000	51.00	54.00	3.00	AV	5.49	Spurious emission
11078.000000	44.30	74.00	29.70	Peak	8.27	Spurious emission

Remark:

1. According to C63.10, if the peak (or quasi-peak) measured value complies with the average limit, it is unnecessary to perform an average measurement, so AV emission value did not show in data table if the peak value complies with average limit.
2. Consequence Level=Reading Level + Correction Factor
 Above 1GHz: Corrector factor = Antenna Factor + Cable Loss- Amplifier Gain
 Below 1GHz: Corrector factor = Antenna Factor + Cable Loss
 (The Reading Level is recorded by software which is not shown in the sheet)

Radiated Emission

EUT: ROX 4.0
 Op Condition: Operated, TX Mode (2457MHz)
 Test Specification: FCC15.249 & 15.209, Antenna: Vertical
 Comment: 3.7 VDC
 Remark: Measurement range up to 25GHz

Test Result	
<input checked="" type="checkbox"/>	Passed
<input type="checkbox"/>	Not Passed

Frequency MHz	Result dBµV/m	Limit dBµV/m	Margin dB	Detector PK/QP/AV	Corr. (dB)	RSE. or Fund.
48.308750	20.90	40.00	19.10	Quasi Peak	17.86	Spurious emission
102.022500	18.43	43.50	25.07	Quasi Peak	15.99	Spurious emission
205.509375	19.38	43.50	24.12	Quasi Peak	16.58	Spurious emission
334.519375	23.19	46.00	22.81	Quasi Peak	19.84	Spurious emission
431.519375	26.45	46.00	19.55	Quasi Peak	22.05	Spurious emission
932.585000	35.17	46.00	10.83	Quasi Peak	29.68	Spurious emission
2008.571429	45.75	74.00	28.25	Peak	-4.99	Spurious emission
2326.666667	47.46	74.00	26.54	Peak	-4.07	Spurious emission
2457.000000	86.85	74.00	-12.85	Peak	-3.78	Fundamental
5784.000000	38.66	74.00	35.34	Peak	3.18	Spurious emission
7367.500000	53.77	74.00	20.23	Peak	5.48	Spurious emission
7367.500000	48.90	54.00	5.10	AV	5.48	Spurious emission
9501.500000	43.12	74.00	30.88	Peak	7.60	Spurious emission

Remark:

1. According to C63.10, if the peak (or quasi-peak) measured value complies with the average limit, it is unnecessary to perform an average measurement, so AV emission value did not show in data table if the peak value complies with average limit.
2. Consequence Level=Reading Level + Correction Factor
 Above 1GHz: Corrector factor = Antenna Factor + Cable Loss- Amplifier Gain
 Below 1GHz: Corrector factor = Antenna Factor + Cable Loss
 (The Reading Level is recorded by software which is not shown in the sheet)

8.2 20dB & 99% Bandwidth

EUT: ROX 4.0
 Op Condition: Operated, TX Mode (2457MHz)
 Test Specification: FCC15.215
 Comment: 3.7 VDC

Test Result
<input checked="" type="checkbox"/> Passed
<input type="checkbox"/> Not Passed

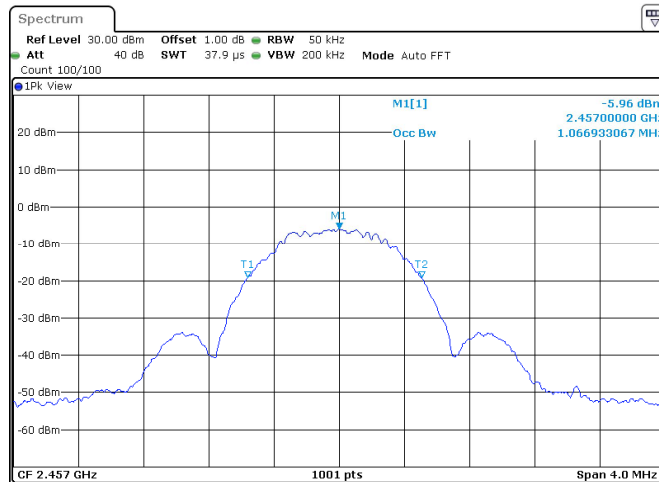
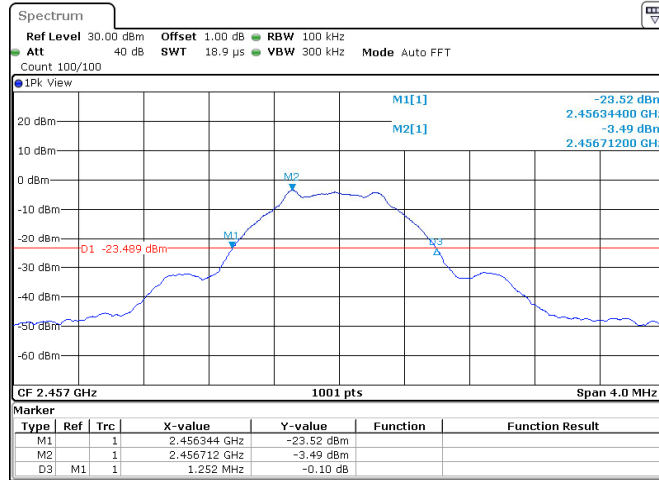

Bandwidth	Measured Value
20dB bandwidth	1.25 MHz
99% OCB	1.07 MHz

8.3 Conducted Emission at AC Power line

EUT: ROX 4.0
 Op Condition: Normal Mode with charging
 Test Specification: FCC15.207
 Comment: 120V AC 60Hz, L Line

Test Result	
<input checked="" type="checkbox"/>	Passed
<input type="checkbox"/>	Not Passed

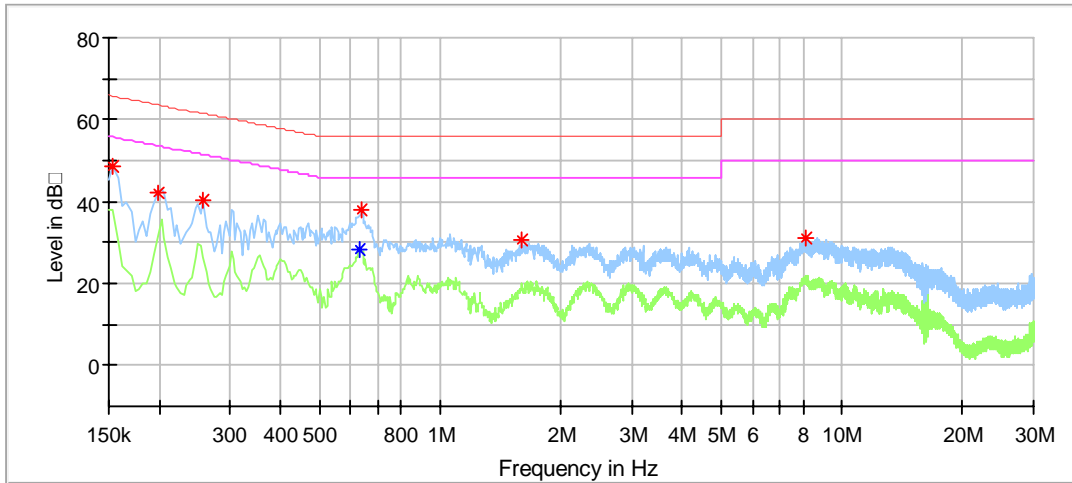

Frequency (MHz)	MaxPeak (dBµV)	Average (dBµV)	Limit (dBµV)	Margin (dB)	Corr. (dB)
0.154000	48.42	---	65.78	17.36	9.63
0.198000	42.15	---	63.69	21.55	9.64
0.258000	40.15	---	61.50	21.34	9.64
0.630000	---	28.49	46.00	17.51	9.65
0.638000	37.87	---	56.00	18.13	9.65
1.598000	30.83	---	56.00	25.17	9.67
8.102000	31.26	---	60.00	28.74	9.85

Conducted Emission at AC Power Line

EUT: ROX 4.0
 Op Condition: Normal Mode with charging
 Test Specification: FCC15.207
 Comment: 120V AC 60Hz, N Line

Test Result	
<input checked="" type="checkbox"/>	Passed
<input type="checkbox"/>	Not Passed

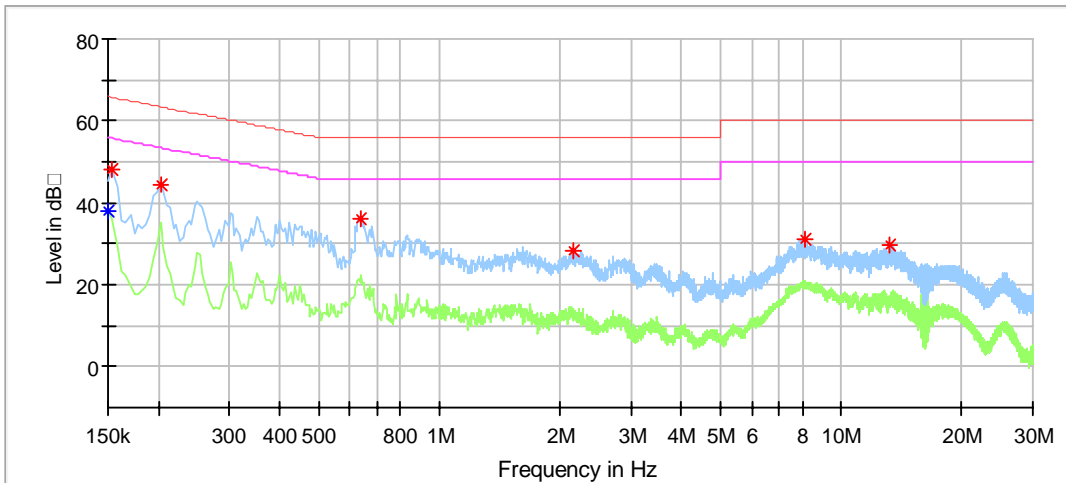

Frequency (MHz)	MaxPeak (dBµV)	Average (dBµV)	Limit (dBµV)	Margin (dB)	Corr. (dB)
0.150000	---	37.78	56.00	18.22	9.61
0.154000	48.03	---	65.78	17.75	9.61
0.202000	44.47	---	63.53	19.06	9.63
0.638000	36.06	---	56.00	19.94	9.65
2.162000	28.15	---	56.00	27.85	9.68
8.102000	30.92	---	60.00	29.08	9.84
13.222000	29.50	---	60.00	30.50	9.89

8.4 Antenna Requirement

EUT: ROX 4.0
Op Condition: Operated, TX Mode
Test Specification: FCC15.203 (b)
Comment: 3.7 VDC

Test Result	
<input checked="" type="checkbox"/>	Passed
<input type="checkbox"/>	Not Passed

Limit

For intentional device, according to FCC Title 47 Part 15.203, an intentional radiator shall be designed to ensure that no antenna other than that furnished by the responsible party shall be used with the device.

Antenna Connector Construction

The antenna used in this product is an integrated antenna on PCB, which in accordance to section 15.203, is considered sufficient to comply with the antenna requirement.

9 Test setup procedure

9.1 Field strength of emissions and Restricted bands

Test Method

- 1: The EUT was placed on a turn table which is 1.5m above ground plane for above 1GHz and 0.8m above ground for below 1GHz at 3-meter chamber room for test. The table was rotated 360 degrees to determine the position of the highest radiation.
- 2: The EUT was set 3 meters away from the interference – receiving antenna, which was mounted on the top of a variable – height antenna tower.
- 3: The height of antenna is varied from one meter to four meters above the ground to determine the maximum value of the field strength. Both horizontal and vertical polarizations of the antenna are set to make the measurement.
- 4: For each suspected emission, the EUT was arranged to its worst case and then the antenna was tuned to heights from 1 meter to 4 meters and the rotatable table was turned from 0 degrees to 360 degrees to find the maximum reading.
- 5: Use the following spectrum analyzer settings According to C63.10:

For Above 1GHz

Span = wide enough to capture the peak level of the in-band emission and all spurious
RBW = 1MHz, VBW \geq 3RBW, Sweep = auto, Detector function = peak and average,
Trace = max hold.

For Below 1GHz

Use the following spectrum analyzer settings:

Span = wide enough to capture the peak level of the in-band emission and all spurious
RBW = 120KHz, VBW \geq 3RBW, Sweep = auto, Detector function = QP,
Trace = max hold.

Field strength of emissions and Restricted bands

Limits

According to §15.249 (a), the field strength of emissions from intentional radiators operated within these frequency bands shall comply with the following:

Fundamental frequency	Field strength of fundamental (millivolts/meter)	Field strength of harmonics (microvolts/meter)
902–928 MHz	50	500
2400–2483.5 MHz	50	500
5725–5875 MHz	50	500
24.0–24.25 GHz	250	2500

According to §15.249 (c), Field strength limits are specified at a distance of 3 meters.
 According to §15.249 (d), Emissions radiated outside of the specified frequency bands, except for harmonics, shall be attenuated by at least 50 dB below the level of the fundamental or to the general radiated emission limits in §15.209, whichever is the lesser attenuation.
 According to §15.205 Unwanted emissions falling into restricted bands in §15.205 (a) shall comply with the limits specified in §15.209.

Frequency MHz	Field Strength uV/m	Field Strength dBµV/m	Detector
30-88	100	40	QP
88-216	150	43.5	QP
216-960	200	46	QP
960-1000	500	54	QP
Above 1000	500	54	AV
Above 1000	5000	74	PK

9.2 Conducted Emission at AC Power line

Test Method

1. The EUT was placed on a table, which is 0.8m above ground plane
2. The power line of the EUT is connected to the AC mains through a Artificial Mains Network (A.M.N.).
3. Maximum procedure was performed to ensure EUT compliance
4. A EMI test receiver is used to test the emissions from both sides of AC line

Limit

Frequency MHz	QP Limit dB μ V	AV Limit dB μ V
0.150-0.500	66-56*	56-46*
0.500-5	56	46
5-30	60	50

*Decreasing linearly with logarithm of the frequency.

9.3 20dB & 99% Bandwidth

Test Method

1. Check the calibration of the measuring instrument using either an internal calibrator or a known signal from an external generator.
2. Position the EUT without connection to spectrum analyser. Turn on the EUT and connect it to measurement instrument. Then set it to any one convenient frequency within its operating range. Set a reference level on the measuring instrument equal to the highest peak value.
3. Measure the frequency difference of two frequencies that were attenuated 20dB from the reference level. Record the frequency difference as the emission bandwidth.

Limits:

According to 15.215 (c) Intentional radiators operating under the alternative provisions to the general emission limits, as contained in §§ 15.217 through 15.257 and in Subpart E of this part, must be designed to ensure that the 20 dB bandwidth of the emission, or whatever bandwidth may otherwise be specified in the specific rule section under which the equipment operates, is contained within the frequency band designated in the rule section under which the equipment is operated. The requirement to contain the designated bandwidth of the emission within the specified frequency band includes the effects from frequency sweeping, frequency hopping and other modulation techniques that may be employed as well as the frequency stability of the transmitter over expected variations in temperature and supply voltage. If a frequency stability is not specified in the regulations, it is recommended that the fundamental emission be kept within at least the central 80% of the permitted band in order to minimize the possibility of out-of-band operation.

10 Appendix A - General Product Information

Radiofrequency radiation exposure evaluation

This exposure evaluation is intended for **FCC ID: M5LROX40**

According to KDB 447498 D01v06 section 4.3.1, For frequencies between 100 MHz to 6GHz and test separation distances ≤ 50 mm, the Numeric threshold is determined as:

Step a)

[(max. power of channel, including tune-up tolerance, mW) / (min. test separation distance, mm)]
 · $[\sqrt{f(\text{GHz})}] \leq 3.0$ for 1-g SAR

>> The fundamental frequency of the EUT is 2457MHz,
 the test separation distance is ≤ 50 mm.
 (Manufacturer specified the separation distance is: 5mm)
 (5mm is the worst case according to the KDB)

Step b)

>> Numeric threshold (2457MHz), $\text{mW} / 5\text{mm} * \sqrt{2.457\text{GHz}} \leq 3.0$
 Numeric threshold (2457MHz) $\leq 9.569\text{mW}$

>> The power (calculated power + tune up tolerance) of EUT at 2457MHz is: 0.15mW
 Which is smaller than the Numeric threshold.
 Therefore, the device is exempt from stand-alone SAR test requirements.

Power calculation (According to C63.10 chapter 9.5)

	Value	Unit
Field Strength Measured (E)	86.85	dB μ V/m
Measurement Distance (D)	3	m
Equivalent Isotropically Radiated Power (E.I.R.P in dBm)	-8.31	dBm
Equivalent Isotropically Radiated Power (E.I.R.P in mW)	0.15	mW

Remark: $\text{EIRP} = E + 20\log(D) - 104.7$

(EIRP is in dBm, E is in dB μ V/m, D is in metres)

Reviewed by:



Eric LI
EMC Project Manager

Prepared by:

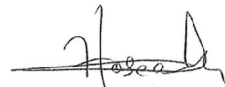
Hosea CHAN
EMC Project Engineer